

CV NATOPS MANUAL

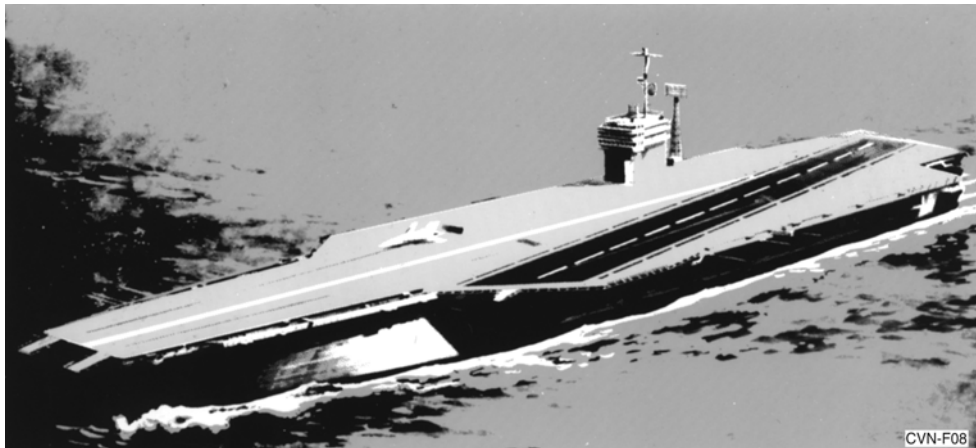

DISTRIBUTION STATEMENT C — Distribution authorized to U.S. Government Agencies and their contractors to protect publications required for official use or for administrative or operational purposes only (15 July 2004). Other requests for this document shall be referred to Commanding Officer, Naval Air Technical Data and Engineering Service Command, Naval Air Station North Island, Bldg. 90, Distribution, P.O. Box 357031, San Diego, CA 92135-7031.

DESTRUCTION NOTICE — For unclassified, limited documents, destroy by any method that will prevent disclosure of contents or reconstruction of the document.

ISSUED BY AUTHORITY OF THE CHIEF OF NAVAL OPERATIONS AND
UNDER THE DIRECTION OF THE COMMANDER,
NAVAL AIR SYSTEMS COMMAND.



DEPARTMENT OF THE NAVY
NAVAL AIR SYSTEMS COMMAND
RADM WILLIAM A. MOFFETT BUILDING
47123 BUSE ROAD, BLDG 2272
PATUXENT RIVER, MD 20670-1547

15 JULY 2004

LETTER OF PROMULGATION

1. The Naval Air Training and Operating Procedures Standardization (NATOPS) Program is a positive approach toward improving combat readiness and achieving a substantial reduction in the aircraft mishap rate. Standardization, based on professional knowledge and experience, provides the basis for development of an efficient and sound operational procedure. The standardization program is not planned to stifle individual initiative, but rather to aid the Commanding Officer in increasing the unit's combat potential without reducing command prestige or responsibility.
2. This manual standardizes ground and flight procedures but does not include tactical doctrine. Compliance with the stipulated manual requirements and procedures is mandatory except as authorized herein. In order to remain effective, NATOPS must be dynamic and stimulate rather than suppress individual thinking. Since aviation is a continuing, progressive profession, it is both desirable and necessary that new ideas and new techniques be expeditiously evaluated and incorporated if proven to be sound. To this end, Commanding Officers of aviation units are authorized to modify procedures contained herein, in accordance with the waiver provisions established by OPNAV Instruction 3710.7, for the purpose of assessing new ideas prior to initiating recommendations for permanent changes. This manual is prepared and kept current by the users in order to achieve maximum readiness and safety in the most efficient and economical manner. Should conflict exist between the training and operating procedures found in this manual and those found in other publications, this manual will govern.
3. Checklists and other pertinent extracts from this publication necessary to normal operations and training should be made and carried for use in naval aircraft.

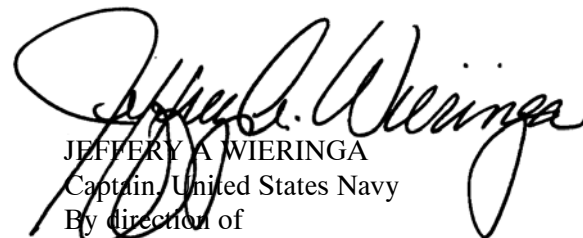
JEFFERY A WIERINGA
Captain, United States Navy
By direction of
Commander, Naval Air Systems Command

<table border="1" style="margin-left: auto; margin-right: auto;"> <tr> <td style="text-align: center; padding: 5px;"> <table border="1" style="margin-left: auto; margin-right: auto;"> <tr> <td style="text-align: center; padding: 5px;">INTERIM CHANGE SUMMARY</td> </tr> </table> </td> </tr> </table>	<table border="1" style="margin-left: auto; margin-right: auto;"> <tr> <td style="text-align: center; padding: 5px;">INTERIM CHANGE SUMMARY</td> </tr> </table>	INTERIM CHANGE SUMMARY
<table border="1" style="margin-left: auto; margin-right: auto;"> <tr> <td style="text-align: center; padding: 5px;">INTERIM CHANGE SUMMARY</td> </tr> </table>	INTERIM CHANGE SUMMARY	
INTERIM CHANGE SUMMARY		

The following Interim Changes have been cancelled or previously incorporated into this manual.

INTERIM CHANGE NUMBER(S)	REMARKS/PURPOSE
1 thru 30	Previously incorporated

The following Interim Changes have been incorporated into this Change/Revision.

INTERIM CHANGE NUMBER(S)	REMARKS/PURPOSE

Interim Changes Outstanding — To be maintained by the custodian of this manual.

INTERIM CHANGE NUMBER	ORIGINATOR/DATE (or DATE/TIME GROUP)	PAGES AFFECTED	REMARKS/PURPOSE

PTTUZYUW RULSABU1234 1182011-UUUU--RHMCSUU.
 ZNR UUUU
 P 282011Z APR 05
 FM COMNAVAIRSYS COM PATUXENT RIVER MD//4.0P//
 TO LSO SCHOOL NORFOLK VA//JJJ//
 INFO COMNAVAIRSYS COM PATUXENT RIVER MD//4.0P/4.1/5.0F/5.1//
 COMNAVAIRFOR SAN DIEGO CA//N32/N421//
 COMNAVAIRES NEW ORLEANS LA//N42/N52//
 CG FOURTH MAW//DOSS//
 COMMARFORLANT//DSS//
 COMMARFORPAC//SAFETY//
 CNATRA CORPUS CHRISTI TX//N3//
 CMC WASHINGTON DC//SD//
 COMNAVSAFECEN NORFOLK VA//11//
 COMNAVAIRWARCENACDIV PATUXENT RIVER//JJJ//
 NAVAIRDEPOT JACKSONVILLE FL//3.3.3//
 COMCARGRU EIGHT
 COMCARAIRWING SEVEN
 USS KITTY HAWK
 USS ENTERPRISE
 USS JOHN F KENNEDY
 USS NIMITZ
 USS DWIGHT D EISENHOWER
 USS CARL VINSON
 USS THEODORE ROOSEVELT
 USS ABRAHAM LINCOLN
 USS GEORGE WASHINGTON
 USS JOHN C STENNIS
 USS HARRY S TRUMAN
 USS RONALD REAGAN
 BT
 UNCLAS//N03711//
 MSGID/GENADMIN/COMNAVAIRSYS COM/4.0P//
 SUBJ/CV NATOPS AND LSO NATOPS PUBLICATIONS INTERIM CHANGES
 /SAFETY OF FLIGHT//
 REF/A/EML/LSO SCHOOL/06APR2005//
 REF/B/DOC/LSO SCHOOL/29MAR2005//
 REF/C/DOC/COMNAVAIRSYS COM/15JUL2004//
 REF/D/DOC/COMNAVAIRSYS COM/17JUN2004//
 NARR/REF A, AN EMAIL, IS LSO SCHOOL (CV/LSO NATOPS COG CMD)
 CONCURRENCE WITH THIS MESSAGE.
 REF B IS CV/LSO OAG POWER POINT PRESENTATION OF ACCEPTED NATOPS
 CHANGES TO REFS C & D.
 REF C IS CV NATOPS, NAVAIR 00-80T-105 DTD 15 JUL 2004.
 REF D IS LANDING SIGNAL OFFICER (LSO) NATOPS, NAVAIR 00-80T-104
 DTD 17 JUN 2004.//
 RMKS/1. THIS MESSAGE IS ISSUED IN RESPONSE TO REFS A AND B. THIS
 MESSAGE ISSUES INTERIM CHANGE (IC) NUMBER 31 TO REF C AND INTERIM
 CHANGE (IC) NUMBER 11 TO REF D.
 2. SUMMARY.
 A. THIS MSG INCORPORATES IDENTIFIED MISCELLANEOUS NATOPS CHANGE
 ITEMS FROM THE APRIL 2004 CV/LSO OAG CONFERENCE FOR INCLUSION IN
 REFS C AND D.
 B. THIS MESSAGE IS FOR NOTIFICATION OF THESE CHANGES ONLY. THE
 DETAILS OF THE ACTUAL CHANGES ARE FOUND IN REPLACEMENT PAGES.
 C. REPLACEMENT PAGES CONTAINING THESE CHANGES FOR DOWNLOADING AND
 INSERTION INTO REFS C AND D WILL BE ATTACHED TO THIS INTERIM CHANGE

MESSAGE WHEN IT IS POSTED ON THE NATEC AND NATOPS WEBSITES (SEE LAST PARA BELOW).

E. THESE REPLACEMENT PAGES IMPACT THE FOLLOWING EXISTING MANUAL(S) PAGES:

1. REF C (CV NATOPS), PAGES 3-5, 5-11 AND 5-19.
2. REF D (LSO NATOPS), PAGES 1-1, 1-4, 2-1, 2-2, 3-1, 4-1, 5-5, 6-3, 6-5, 6-6, 6-7, 6-8, 6-12, AND 8-2.

3. POINTS OF CONTACT:

A. CV/LSO NATOPS PROGRAM MANAGER IS LCDR JOSEPH KRASINSKI, LSO SCHOOL, TEL DSN 433-2515 OR COMM (757) 433-2515, EMAIL: JOSEPH.KRASINSKI(AT)NAVY.MIL

B. NAVAIR POCS:

1. MARTY SCANLON, 4.0P NATOPS INTERIM CHANGE COORDINATOR, TEL DSN 757-6045, OR COMM (301) 757-6045, EMAIL: MARTIN.SCANLON(AT)NAVY.MIL
2. LCDR JR NASH, 4.0P NATOPS OFFICER, TEL DSN 995-2052, OR COMM (301) 995-2052, EMAIL: JAMES.NASH(AT)NAVY.MIL
3. KRISTIN SWIFT, 4.0P NATOPS CHIEF ENGINEER, TEL DSN 995-4193 OR COMM (301) 995-4193, EMAIL: KRISTIN.SWIFT(AT)NAVY.MIL

4. THIS MESSAGE WILL BE POSTED ON THE NATEC WEBSITE, WWW.NATEC.NAVY.MIL WITHIN 15 DAYS OF RELEASE. NEW NATOPS IC MESSAGES MAY BE FOUND IN TWO PLACES ON THIS WEBSITE:

- (1) IN THE NATOPS IC DATABASE FOUND UNDER THE TMAPS OPTION, AND
- (2) IN THE AFFECTED PUBLICATIONS(S) JUST AFTER THE IC SUMMARY PAGE. IF THE IC MESSAGE INCLUDES REPLACEMENT PAGES, THEY WILL BE ADDITIONALLY PLACED WITHIN THE MANUAL AND REPLACED PAGES DELETED. MESSAGES ARE NORMALLY POSTED IN THE DATABASE BEFORE APPEARING IN THE PUBLICATION. THIS MESSAGE WILL ALSO BE POSTED ON THE NATOPS WEBSITE, NATOPS.NAVAIR.NAVY.MIL. IF UNABLE TO VIEW THIS MESSAGE ON EITHER THE NATEC OR NATOPS WEBSITES, INFORM THE NATOPS GLOBAL CUSTOMER SUPPORT TEAM AT (301) 342-3276, DSN 342-3276, OR BY EMAIL AT NATOPS(AT)NAVY.MIL.//

BT

#1234

NNNN

NAVAIR 00-80T-105
CV NATOPS
NATOPS MANUAL
INTERIM CHANGE 31
REPLACEMENT PAGES

1. Replacement pages for Interim Change 31 to the CV NATOPS, NAVAIR 00-80T-105 dated 15 Jul 2004, are attached as follows:

Page	Page Version Marking
-----	-----
3-5	Original W/IC 31
3-6	Original
5-11	Original W/IC 31
5-12	Original
5-19	Original W/IC 31
5-20	Original W/IC 31
5-20A/(5-20B blank)	Original W/IC 31

within visual range of the ship will normally be controlled by the air officer. Outside the visual range of the ship, aircraft in an emergency shall be controlled by either CDC or CATCC. Aircraft in distress should not change radio frequencies if satisfactory radio contact is established.

3.5.2 Basic Procedures. The procedures for pilots to follow when experiencing communications and/or navigation equipment failures are listed in Figure 3-1. Controlling agencies shall be familiar with and alert for conditions indicating communication or navigation failures and perform the following as appropriate:

1. Attempt to establish communications with the aircraft.
2. Vector the aircraft as appropriate.

If unable to communicate with the aircraft in difficulty:

1. Identify on radar and maintain a track.
2. Vector available aircraft to join if practical.
3. Alert air operations watch officer and PriFly.
4. Broadcast instructions and essential information on normal control frequencies and guard.

Emergency procedures during penetration or letdown are covered in Chapter 5. Emergency procedures for aircraft system failures are covered in the appropriate aircraft NATOPS flight manual. Lost communication emergency squawks are listed in Figure 3-2.

3.6 PLANE GUARD HELICOPTER

3.6.1 Control Authority. A helicopter, when designated primary plane guard, shall be under the operational control of the air officer during launches and recoveries. During Case II or III operations or advisory control, the base recovery course and all course changes shall be provided by CATCC using a frequency monitored by primary flight control. CATCC shall conduct a radio check with the plane guard

helicopter at least every 20 minutes during Case III. Concurrent USW/plane guard helicopter operations may be conducted provided a responsive plane guard capability is maintained during launch/recovery.

3.6.2 Plane Guard Station. During carrier qualification landings and/or when concurrent tactical/plane guard operations are not authorized, the pattern depicted in Figure 3-3 should be used. For concurrent operation, during launch/recovery, the designated planeguard helicopter is “on station” when operating within 20 NM (Day) or 10 NM (Night) of the carrier. The helicopter shall remain within UHF range and monitor the assigned air control frequency at all times.

3.6.3 Restrictions. During launch/recovery, no concurrent USW/plane guard operations shall be conducted within the shaded area depicted in Figure 3-4 without the explicit approval of the air officer. The maximum altitudes when conducting concurrent USW/plane guard operations shall be as depicted in Figure 3-4.

3.6.4 Search and Rescue. In the event of a plane guard incident, the designated plane guard helicopter shall immediately respond unless otherwise directed by the air officer.

The air officer normally will be responsible for controlling plane guard efforts when they are within sight of the ship. CDC/CATCC normally will control plane guard efforts when outside visual contact of the air officer. The CDC officer should normally be responsible as the ship’s overall plane guard coordinator. SAR requirements are listed in Figure 3-5.

A switch to a discrete plane guard frequency will be made when directed by the controlling agent/agency.

WARNING

During the recovery of aircraft with forward firing ordnance, the plane guard helicopter shall not be positioned on the starboard side from the 360 to the 090 degree relative bearing within 5NM from the carrier.

TYPE OF FAILURE	FLIGHT CONDITIONS	
Transmitter failure with or without receiver failure (navigation aids serviceable).	VMC	*IMC
	<ol style="list-style-type: none"> 1. Join up if possible. 2. Maintain VMC. <ol style="list-style-type: none"> a. Enter VMC landing pattern. b. Use standard visual signals when in range of ship. c. Watch for light signals from ship. 3. Squawk Mode III 7600, "IDENT," and Mode I in accordance with Figure 3-2. 4. In receiving, follow instructions. 5. Broadcast intentions periodically, whether or not transmitter is known to be serviceable. 6. Tune in parent CV data-link frequency. 	<ol style="list-style-type: none"> 1. Transition to VMC if possible and continue VMC. 2. Proceed to emergency marshal. 3. Squawk Mode III 7600, "IDENT," and Mode 1 in accordance with Figure 3-2. 4. Watch for joinup. 5. Hold at emergency marshal until EEAT. 6. Commence approach at EEAT. Squawk in accordance with Figure 3-2. 7. If receiving, follow instructions. 8. Broadcast intentions periodically whether or not transmitter is known to be serviceable. 9. Tune in parent CV data-link frequency.
Navigation aids and transmitter failures, with or without receiver failure.	<ol style="list-style-type: none"> 1. Perform same procedures as for communications failure, or 2. When position is unknown: <ol style="list-style-type: none"> a. Navigate by DR to best position. b. Squawk in accordance with Figure 3-2 or EMERGENCY as required. c. Fly appropriate triangles. d. Watch for join up. 3. Tune in parent CV data link frequency. 4. If all above fails, bingo to nearest suitable field at appropriate fuel state. 	<ol style="list-style-type: none"> 1. Transition to VMC if possible and maintain VMC. 2. Navigate by DR to best position. 3. Squawk in accordance with Figure 3-2 or EMERGENCY as required. 4. Fly appropriate triangles. 5. Watch for joinup. 6. If receiving, follow instructions. 7. Broadcast intentions periodically whether or not transmitter is known to be serviceable. 8. Tune in parent CV data-link frequency.
<p>* All procedures are for single aircraft. When in company, VMC or IMC, remain in company and use hand signals between aircraft.</p>		

Figure 3-1. Basic Emergency Procedures for Communication/Navigational Equipment Failure

data-link communications between aircraft and ship.

2. The final controller will acquire the aircraft between 3.5 and 8 miles and the PALS ready/lock-on discrete light will illuminate. At that time, the final controller shall report lock-on with range, verify needles, issue instructions as necessary for the aircraft to intercept the centerline, and instruct the pilot to report “coupled.”
3. At lock-on, the pilot selects PALS display (agreement of aircraft needles and PALS display will verify PALS is locked on correctly to the aircraft). For example: “201 lock-on, 5 miles. Say needles.” The pilot shall report needle position. For example: “201, needles up and right.” The controller reports, “Concur report coupled.”

WARNING

The controller shall not transmit commands until the pilot has reported “coupled.”

Note

If aircraft is unable to couple or uncouples, continue approach Mode II, ICLS, Mode III.

4. The final controller shall report sending commands. The command control discrete light will illuminate, indicating the PALS system is sending command signals via data link. The pilot shall acknowledge receiving data-link commands by reporting “command control.” Thirty seconds coupled flight should be flown prior to intercepting glidepath.
5. The final controller shall advise the pilot when “approaching tipover” (glidepath) and should issue range each mile. At tipover, the pilot should switch to ILM, if available, to verify agreement of ILM and AN/SPN-42/46 displays. The ILM shall be used to monitor the approach to PALS Mode I minimums. ILM and AN/SPN-42/46 displays shall agree to within 2 to 3 needle widths until reaching PALS Mode I minimums.
6. The final controller shall advise the pilot at minimums unless the LSO has previously

assumed responsibility. The pilot shall respond with “ball” report and include the word “coupled.” For example: “301 Hornet ball, five point three, coupled.” Expect ILM needle deviation errors inside one-quarter nm from touchdown. Use the Fresnel lens as the primary monitor inside PALS Mode I minimums.

WARNING

- PALS discrete lights shall be closely monitored throughout the approach.
- The CCA Officer shall suspend Mode I approaches when PALS Certification/Verification restrictions (i.e., WOD limits, deck motion parameters, etc.) are exceeded.

5.4.7.5 PALS Mode IA Approach (ILM Not Required).

Mode IA approaches are conducted the same as Mode I except the pilot shall uncouple at or prior to reaching approach minimums and report “uncoupled.” If the pilot uncouples at “ball” call, he shall include the word “uncoupling” in the ball report. For example: “201 uncoupling, hornet, ball, five point three, manual/auto.” When the pilot reports uncoupling, the controller shall downgrade the PALS to Mode II.

5.4.7.6 PALS Mode II Approach (ILM Not Required)

1. Mode II approaches are conducted the same as Modes I/IA until receipt of PAL ready/lock-on discrete light. At that time, the controller shall report lock-on with range, verify needle presentation, and issue instructions as required. For example: “201, lock-on, 5 miles, say needles.” The pilot shall report needle position. For example: “201, needles up and right.” The controller shall concur or downgrade the approach to ICLS or Mode III and advise the pilot. For example: “201, concur” or “201, disregard needles, downgrade, fly Bullseye or Mode III.” The controller shall monitor the approach, advise the pilot when approaching glidepath, and should inform him of range each mile. The controller shall advise the pilot when at minimums unless the LSO has previously assumed responsibility. The pilot shall respond with a ball report.

2. PALS Mode IIT approach is a training approach using needles instrument presentation (Mode II) as well as Mode III information.

5.4.7.7 PALS Mode IID Approach (ILM Not Required). For those qualified aircraft equipped with Mode IID (flight director) flying CCA approaches to a Mode IID certified ship, the following procedures shall be followed:

1. Mode IID approaches are conducted the same as Modes I/IA/II until receipt of PALS ready/lock-on discrete light. After receipt of PALS ready/lock-on discrete light, the final controller shall report lock-on with range, verify needles, and issue instructions as necessary for the aircraft to intercept the centerline.
2. At lock-on, the pilot selects PALS display (agreement of aircraft needles and PALS display will verify PALS is locked on correctly to the aircraft). For example, "101, needles up and right." The controller shall concur and report, "Concur, sending flight director", or, "Disregard needles, downgrade Mode III."

Note

If aircraft is unable to receive flight director data or if receipt of flight director data is terminated, continue Mode II or Mode III.

3. When the controller enables the flight director mode, the flight director symbol is automatically displayed on the aircraft HUD. The pilot shall acknowledge receiving the data-link signals by reporting, "Receiving flight director."
4. The final controller shall advise the pilot when approaching glidepath and should issue range with each mile. The final controller shall advise the pilot at minimums unless the LSO has previously assumed responsibility. The pilot shall respond with a ball report.

5.4.7.8 PALS Mode III Approach. Jet and turboprop aircraft shall pass through the 6-mile DME fix at 1,200 feet altitude, 150 knots, in the landing configuration and commence slowing to final approach speed. The 1,200-foot altitude will be maintained at approach speed until intercepting the glidepath

(approximately 3 miles, dependent upon glideslope angle utilized) unless otherwise directed.

Helicopters shall pass the 3-mile DME fix at 500 feet in a landing configuration and maintain 500 feet until interception of the glidepath or until otherwise directed.

The controller shall provide glideslope, azimuth, and range information. Pilots may use the 400 foot-per-mile rule to help schedule glideslope maintenance. The controller shall advise the pilot when at minimums unless the LSO has previously assumed responsibility. The pilot shall respond with a ball report.

Note

Lock-on must be maintained until touchdown during all PALS approaches to provide the LSO with essential course and glidepath information.

5.4.7.9 ICLS Approach. Jet and turboprop aircraft shall pass through the 6-mile DME fix at 1,200 feet altitude, 150 knots, in the landing configuration and commence slowing to final approach speed. ILM information shall be used to intercept and fly centerline and glideslope, and TACAN information shall be used for DME information until reaching ICLS minimum. ILM information may be used to achieve lineup early in the approach.

5.4.7.10 Nonprecision Approach. When precision approach radar or suitable visual landing aids are not available, aircraft on final approach will continue descent to 600 feet after passing the 6-mile DME fix. The final controller will provide sufficient information to the pilot for him to maintain an accurate azimuth and altitude until reaching nonprecision minimums.

Note

Per NATOPS Instrument Flight Manual (NAVAIR 00-80T-112) the pilot should establish a rate of descent which will ensure reaching the MDA at or before the missed approach point.

5.4.8 Missed Approach/Waveoff/Bolter. Jet and turboprop aircraft shall climb straight ahead on the extended final bearing to 1,200 feet altitude and wait for instructions from approach control.

3. Arresting gear engines are not properly set and in battery.
4. There is a known or suspected malfunction of recovery equipment.
5. After each touch and go, arrestment, bolter, or waveoff.

Note

During night operations when the deck is open, but momentarily foul, the landing deck lights will remain on and foul deck waveoff will be controlled by the LSO.

During night operations, green wands shall be used only by those air department personnel authorized to launch aircraft or signal a clear deck.

5.5.4 Control of the Landing Pattern (VMC).

The air officer is charged with the overall control of the VMC landing pattern (Figure 5-6) and is assisted by the LSO. Specific responsibilities are assigned as follows.

5.5.4.1 Air Officer

1. Provide pilot with sufficient information to ensure that aircraft are established in the landing pattern in time to meet the expected Charlie time.
2. Assign or revise the landing order as necessary.
3. Regulate the number of aircraft in the landing pattern to ensure a steady flow of traffic while preventing the pattern from becoming extended or overcrowded.
4. Monitor the landing interval.
5. Whenever possible, maintain visual contact with all aircraft in the Delta and Charlie pattern.
6. Maintain an accurate count of the number of aircraft to be recovered, and inform the bridge when only two remain.
7. Monitor the upwind pattern, being particularly alert to warn pilots of aircraft boltering or waving off of their proximity to aircraft launching or breaking.
8. Maintain visual contact with aircraft that have radio failure and instruct the LSO with regard to visual signals to be given.

9. Inform the LSO of any unusual condition(s) affecting the normal recovery of aircraft.

5.5.4.2 LSO (Under the Supervision of the Air Officer)

1. Control all fixed-wing aircraft approaches after the 180° position.
2. Ensure that approaching aircraft are properly configured.
3. Monitor the operation of the OLS and crosscheck the approach radar/ICLS glidepath angle.
4. Instruct and supervise the LSO talker and hook spotter.
5. Assist in controlling aircraft that have radio failure by flashing the cut or waveoff lights in accordance with signals delineated in Figure 5-11.
6. Whenever possible, maintain visual contact with all aircraft in the Charlie pattern.
7. Inform the air officer of any unusual conditions affecting the safe recovery of aircraft.

5.6 RECOVERING HELICOPTERS

5.6.1 Recovery Procedures. Normally, helicopters will be recovered after all fixed-wing aircraft. Helicopters recovering after night plane guard duties should be provided positioning information by CATCC in order to expeditiously intercept the glideslope and effect a landing following recovery of the last fixed-wing aircraft. When a flight of helicopters is being recovered under VMC, the leader of the flight should plan to be at the ramp within a minimum safe interval after the last fixed-wing aircraft has landed. The helicopter which is the farthest advanced on the inbound radial and has not turned to parallel the ship's course will be considered No. 1 in the landing pattern and should expeditiously effect a landing following recovery of the last fixed-wing aircraft. The helicopter cleared No. 1 to land should be assigned a landing spot farthest forward into the wind. Subsequent helicopters should be cleared to land in sequence behind the No. 1 helicopter. In the event the last fixed-wing aircraft waves off, all helicopters will return to the Delta pattern (see Figure 5-6). Prior to issuing landing clearance, the air officer shall ensure the helicopter may land within

the relative wind envelope prescribed in the respective aircraft NATOPS flight manual, and the tower shall transmit relative wind direction, speed, and landing spot(s). For landings not oriented to the angle or axial centerline (day VMC only), the air officer will ensure an adequate waveoff path is available to the helicopter.

WARNING

Because of the severe rotorwash and wing-tip vortices produced by CH-53E and MH-53E helicopters, land/launch operations should not be conducted upwind of other aircraft or any unsecured area. Because of this severe hazard, consideration should be given to conducting CH-53E and MH-53E operations from after-deck spots only.

Note

- Rotating beacon light signals for helicopter operations are located in Figure 3-1 of the Aircraft Signals NATOPS Manual (NAVAIR 00-80T-113).
- Army helicopters are not equipped with an automatic blade fold/spread system.

Time for manually folding and spreading main rotor blades should be taken into account for tactical planning during shipboard operations.

- Certain Army and Air Force helicopters are not equipped with a rotor brake. Extended rotor coast down times can be expected. These times can vary with relative wind speed and direction, and can exceed 8 minutes in winds as light as 20 knots. The ship shall be ready to provide optimum winds for the windmilling stop of the rotor system.

During Case III recoveries, the approach shall be flown as directed by CATCC until the pilot acquires visual contact with the optical landing aids, at which time the pilot shall “call the ball.” Control will then be assumed by the air officer, who shall issue final landing clearance. In the event of a waveoff, the pilot shall parallel the final bearing course and report to CATCC for control. At night, navigation lights shall be steady bright and anticollision lights on until established on the final bearing, at which time the position lights shall be placed on dim and steady.

The forward anticollision light shall be turned off when the meatball is in sight.

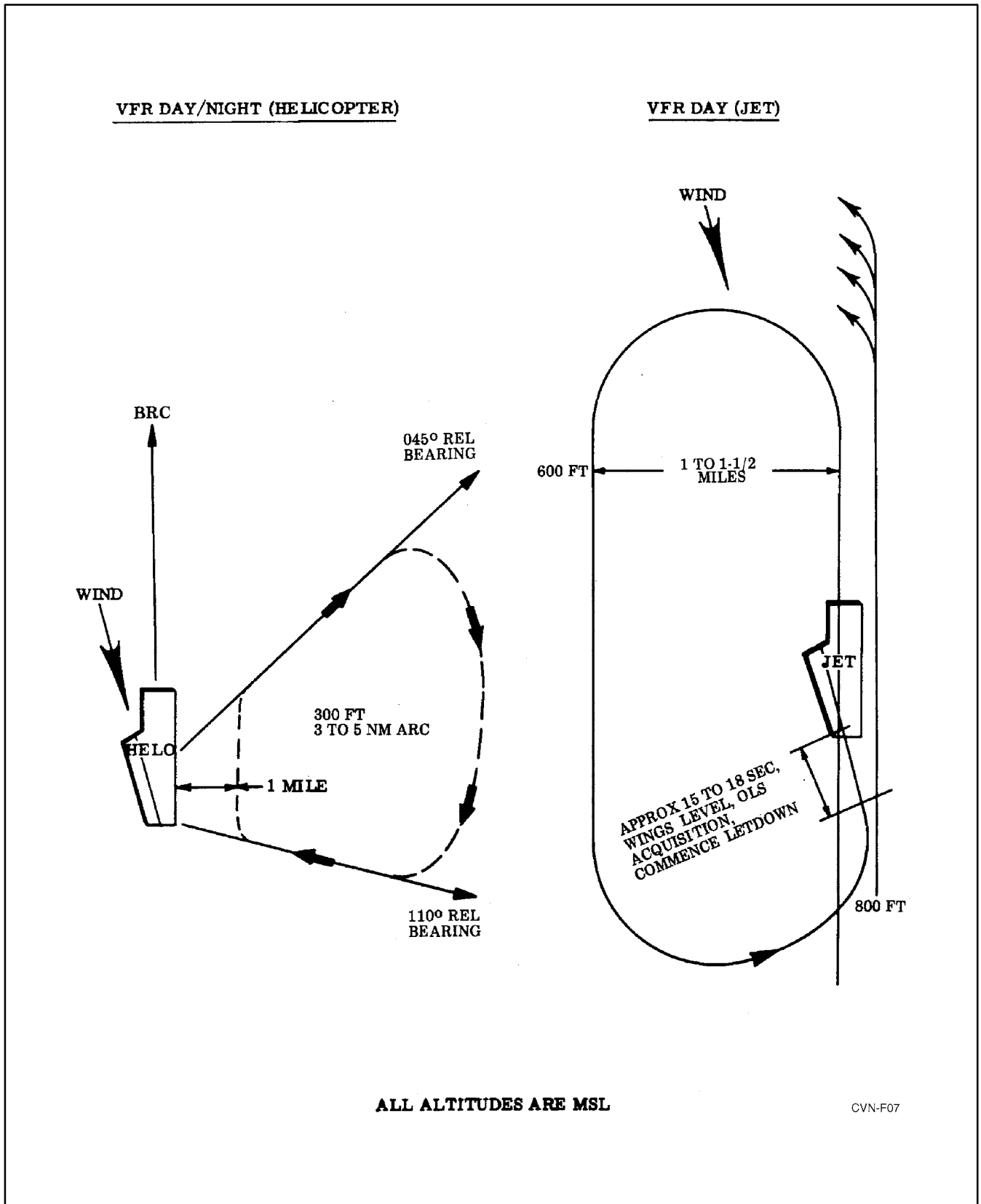

Figure 5-6. Carrier Landing and Patterns and Approaches

Summary of Applicable Technical Directives

Information relating to the following recent technical directives has been incorporated into this manual.

CHANGE NUMBER	DESCRIPTION	DATE INC. IN MANUAL	VISUAL IDENTIFICATION

Information relating to the following applicable technical directives will be incorporated in a future change.

CHANGE NUMBER	DESCRIPTION	DATE INC. IN MANUAL	VISUAL IDENTIFICATION

RECORD OF CHANGES

Change No. and Date of Change	Date of Entry	Page Count Verified by (Signature)

Table of Contents

	<i>Page No.</i>
CHAPTER 1 — PREDEPLOYMENT	
1.1	TRAINING REQUIREMENTS 1-1
1.2	ADDITIONAL REQUIREMENTS 1-1
1.3	PREDEPLOYMENT LECTURE SYLLABUS 1-2
1.3.1	All Personnel 1-2
1.3.2	Plane Captains 1-2
1.3.3	Maintenance Personnel 1-2
1.3.4	Flight Crewmembers 1-2
1.3.5	Ordnance Personnel 1-2
CHAPTER 2 — PREPARING FOR FLIGHT OPERATIONS	
2.1	THE AIR PLAN 2-1
2.1.1	The Ordnance Load Plan 2-2
2.2	FLIGHT QUARTER STATIONS 2-2
2.2.1	Aqueous Film Forming Foam System and Mobile Firefighting Equipment 2-2
2.2.2	Preliminary Procedures — CATCC 2-2
2.2.3	Preliminary Procedures — Air Officer 2-5
2.3	BRIEFING 2-6
2.4	FLIGHT PLANS AND ADVISORIES 2-6
2.4.1	Close Proximity Operations 2-6
2.5	CHANGES IN PILOT OR AIRCRAFT ASSIGNMENTS 2-7
2.6	AIR TRANSFER OFFICER 2-7
2.7	PASSENGER TRANSFERS 2-7
CHAPTER 3 — AIR TRAFFIC CONTROL DOCTRINE	
3.1	RESPONSIBILITIES 3-1
3.1.1	Operations Officer 3-1
3.1.2	Air Operations Officer 3-1
3.1.3	Air Officer 3-1
3.1.4	Landing Signal Officer 3-1

3.1.5	Landing Signalman Enlisted	3-1
3.1.6	Pilots	3-1
3.1.7	Combat Direction Center Officer	3-1
3.2	CONTROL CRITERIA	3-2
3.2.1	Degrees of Control	3-2
3.2.2	Electronic Emission Control	3-3
3.3	SEPARATION CRITERIA	3-3
3.3.1	Lateral Separation	3-3
3.3.2	Vertical Separation	3-3
3.4	COMMUNICATION CONTROL	3-4
3.4.1	Control of Radio Circuits	3-4
3.4.2	Voice Procedures	3-4
3.4.3	Recording of Radio Circuits	3-4
3.4.4	Communication Security	3-4
3.5	EMERGENCY CONTROL PROCEDURES	3-4
3.5.1	Initial Control Responsibility	3-4
3.5.2	Basic Procedures	3-5
3.6	PLANE GUARD HELICOPTER	3-5
3.6.1	Control Authority	3-5
3.6.2	Plane Guard Station	3-5
3.6.3	Restrictions	3-5
3.6.4	Search and Rescue	3-5

CHAPTER 4 — LAUNCHING AIRCRAFT

4.1	PRELAUNCH PROCEDURES	4-1
4.1.1	Manning Aircraft	4-2
4.1.2	COD/VOD Aircraft	4-2
4.2	LAUNCHING FIXED-WING AIRCRAFT	4-2
4.2.1	Engine Start and Turnup	4-2
4.2.2	Final Preparations for Launch	4-3
4.2.3	Taxiing	4-3
4.2.4	Catapult Launching	4-4
4.3	ICCS CATAPULT LAUNCH PROCEDURES	4-6
4.3.1	ICCS Emergency Procedures	4-10
4.3.2	ICCS Catapult Safety Precautions	4-11

4.4	MODE I LAUNCHING PROCEDURES	4-12
4.5	NON-ICCS CATAPULT LAUNCH PROCEDURES	4-12
4.5.1	Deck Launching	4-14
4.5.2	F-14 B/D FCF Reduced Arrestment Thrust System	4-15
4.6	LAUNCHING HELICOPTERS	4-15
4.6.1	Helicopter Launch Procedures	4-15
4.6.2	Helicopter Safety Precautions	4-16
4.6.3	Rescue Helicopter Launching Criteria	4-17
4.7	RESCUE HELICOPTER INFORMATION	4-17
4.8	DOWNED AND STANDBY AIRCRAFT	4-18
4.8.1	Downed Aircraft	4-18
4.8.2	Standby Aircraft	4-18
4.9	RESPOT FORWARD	4-18
4.10	EMERGENCY AFTER LAUNCH	4-18
4.10.1	Visual Meteorological Conditions	4-18
4.10.2	Night/Instrument Meteorological Conditions	4-18
4.11	LAUNCHING CONDITION AIRCRAFT	4-18
4.11.1	Fixed Wing	4-19
4.11.2	Helicopters	4-19
4.12	CONTROL OF DEPARTING AIRCRAFT	4-20
4.12.1	Departure Radials	4-20
4.12.2	Departure Communication Procedures	4-20
4.12.3	Fixed-Wing Departures/Rendezvous	4-21
4.12.4	Helicopter Departure	4-22

CHAPTER 5 — RECOVERING AIRCRAFT

5.1	ARRIVAL PROCEDURES	5-1
5.1.1	Entering the Carrier Control Area	5-1
5.1.2	Arrival Information	5-1
5.1.3	Transient Helicopters	5-1
5.2	CASE I	5-1
5.2.1	Jet/Turboprop Aircraft Port Holding/Spin Pattern	5-1
5.2.2	COD Aircraft	5-2

5.2.3	Helicopters	5-2
5.2.4	Landing Pattern Entry	5-2
5.2.5	Voice Reports	5-2
5.2.6	ZIP LIP	5-3
5.2.7	Drag	5-3
5.2.8	Upwind Turn	5-3
5.3	CASE II	5-3
5.4	CASE III	5-3
5.4.1	Marshal Procedures	5-3
5.4.2	Marshal Instructions	5-4
5.4.3	General Instructions	5-5
5.4.4	Departing Marshal	5-5
5.4.5	Initial Separation	5-5
5.4.6	Frequency/IFF/SIF Changes	5-5
5.4.7	Instrument Approach Procedures	5-5
5.4.8	Missed Approach/Waveoff/Bolter	5-12
5.4.9	Delta Procedures	5-13
5.4.10	Night EMCON Recovery	5-13
5.4.11	Communication or NAVAID Failure During Approach	5-14
5.4.12	Radar Handoff Procedures	5-15
5.4.13	Voice Communication Procedures	5-15
5.5	RECOVERING FIXED-WING AIRCRAFT	5-16
5.5.1	Preparation for Recovery	5-16
5.5.2	Approach and Landing	5-17
5.5.3	Special Safety Precautions	5-17
5.6	RECOVERING HELICOPTERS	5-19
5.6.1	Recovery Procedures	5-19
5.6.2	NVG Equipment Aided Approaches	5-21
5.6.3	Recommended Deck Lighting Configuration for Helicopter NVG Aided Takeoff and Landing	5-21
5.6.4	Special Safety Precautions	5-21
5.7	SPECIAL PROCEDURES FOR CARRIER QUALIFICATION LANDING	5-22
5.7.1	Fixed-Wing Aircraft	5-22
5.7.2	Helicopters	5-23
5.8	EMERGENCY LANDING	5-23
5.8.1	Fixed-Wing Aircraft	5-23
5.8.2	Helicopters	5-24

5.9	EMERGENCY SIGNALS	5-24
5.9.1	Visual Signals to Ship From Aircraft With Radio Failure	5-24
5.9.2	Visual Signals to Aircraft From Ship Under EMCON or Lost Communication Conditions	5-24
5.9.3	Carrier Pattern Emergencies	5-24
5.9.4	Day Communication Emergencies	5-24
5.9.5	Night Communication Emergencies	5-24
5.10	TANKER OPERATIONS	5-24
5.10.1	Recovery Tanker Procedures	5-24
5.10.2	Rendezvous Procedures	5-25
5.10.3	Recovery Tanking Pattern	5-25
5.10.4	Recovery (Case III)	5-25
5.10.5	Fuel Transfer and Dump Control	5-25
5.11	DIVERSION OF AIRCRAFT	5-27

CHAPTER 6 — AIRCRAFT AND WEAPONS HANDLING PROCEDURES

6.1	GENERAL REQUIREMENTS	6-1
6.2	BRIEFING	6-1
6.3	MAINTENANCE LIAISON	6-1
6.4	EQUIPMENT	6-2
6.5	MOVEMENT OF AIRCRAFT	6-2
6.5.1	Elevator Operation	6-5
6.5.2	Report of Damage to Aircraft	6-6
6.5.3	Aircraft Security	6-6
6.5.4	ILARTS Special Events Coverage	6-6
6.6	VERTICAL REPLENISHMENT	6-6
6.7	FUELING AND DEFUELING AIRCRAFT	6-7
6.7.1	Fueling and Defueling	6-7
6.7.2	Hot Refueling	6-7
6.8	WEAPON HANDLING PROCEDURES	6-8
6.8.1	Weapon Definitions	6-8
6.8.2	Weapon Movement	6-9
6.8.3	Weapon Loading/Downloading	6-9

6.8.4	Arming	6-11
6.8.5	Intent to Launch Weapons	6-11
6.8.6	Hung/Unexpended Weapons	6-12
6.8.7	Dearming	6-12
6.8.8	Maintenance on Loaded Aircraft	6-13
6.8.9	Abort/Strikedown	6-14
6.8.10	Emergency Procedures	6-14
6.8.11	Helicopter Procedures	6-14

APPENDIX A — AIRCRAFT HANDLING SIGNALS

APPENDIX B — AIRCRAFT ARMING AND SAFING SIGNALS

APPENDIX C — WEAPONS LOADING/STRIKEDOWN/DOWNLOADING AND RECOVERY GUIDE

List of Illustrations

*Page
No.*

CHAPTER 2 — PREPARING FOR FLIGHT OPERATIONS

Figure 2-1. Authorized Flight Quarters	2-3
Figure 2-2. Standard Signal Wands	2-5

CHAPTER 3 — AIR TRAFFIC CONTROL DOCTRINE

Figure 3-1. Basic Emergency Procedures for Communication/Navigational Equipment Failure	3-6
Figure 3-2. Lost Communication Emergency Squawks	3-7
Figure 3-3. Starboard Holding Pattern	3-8
Figure 3-4. Helicopter Restrictions During Launch/Recovery	3-8
Figure 3-5. Minimum SAR Requirements	3-9

CHAPTER 5 — RECOVERING AIRCRAFT

Figure 5-1. Legend Chart for Aircraft Carrier Instrument Approach Procedures	5-6
Figure 5-2. Approach Chart CV-1 TACAN (Jet and Turboprop)	5-7
Figure 5-3. Approach Chart CV-2 TACAN Overhead (Jet and Turboprop)	5-8
Figure 5-4. Approach Chart CV-3 TACAN (Helicopter)	5-9
Figure 5-5. Approach Weather Minimums	5-10
Figure 5-6. Carrier Landing and Patterns and Approaches	5-20
Figure 5-7. Emergency Signals to Ship From Fixed-Wing Aircraft With Radio Failure	5-26
Figure 5-8. Emergency Signals to Ship From Helicopters With Radio Failure	5-26
Figure 5-9. Visual Signals to Aircraft From Ship Under EMCON or Lost Communications	5-29
Figure 5-10. Carrier Pattern Emergencies	5-30
Figure 5-11. Day Communication Emergencies	5-31
Figure 5-12. Night Communication Emergencies	5-32
Figure 5-13. Tanker Rendezvous Pattern	5-33

GLOSSARY

A

advisory control. A form of air traffic control in which the controlling agency monitors radar and radio contact with aircraft under its control and provides traffic advisories. Traffic separation is the responsibility of the individual pilot, with the assistance provided by the control agency.

air operations. That section of the operations department responsible for coordinating all matters pertaining to air operations including the proper functioning of the CATCC.

approach control. A control position in CATCC responsible for providing positive control of aircraft on approach during Case II and III. Tasks include making holes for bolter/waveoff traffic and maintaining appropriate interval.

B

ball. A pilot report indicating that the visual landing aid is in sight.

base recovery course (BRC). The ship's magnetic heading during flight operations.

bingo. An order to proceed and land at the field specified, utilizing a bingo profile. Aircraft is considered to be in an emergency/fuel critical situation. Bearing, distance, and destination shall be provided.

break time (ready deck). Anticipated time specified by PriFly that the deck will be ready to recover aircraft and the first aircraft of a Case II recovery is expected to be at the break.

bullseye. A term referring to the ILM.

C

carrier air traffic control center (CATCC). CATCC is comprised of two

interdependent work centers, Air Operations (Air Ops) and Carrier Controlled Approach (CCA). It is the centralized agency responsible for the status keeping of all carrier air operations and control of all airborne aircraft under the operations officer's cognizance except those being controlled by CDC and the air officer.

carrier control area. A circular airspace within a radius of 50 nm around the carrier, extending upward from the surface to infinity, under control of CATCC except for those aircraft operating under control of the air officer during Case I and II operations.

Note

The radius and height may be limited because of adjacent controlled airspace.

carrier control zone. The airspace within a circular limit defined by 5 miles horizontal radius from the carrier, extending upward from the surface to and including 2,500 feet unless otherwise designated for special operations, and is under the cognizance of the air officer during VFR conditions.

center. A collective radio call prefixed by a ship's code name which is used in the same manner as the shore-based counterpart.

CHARLIE. Signal for aircraft to land aboard the ship. A number suffix indicates time delay before landing.

Clara. A pilot transmission indicating the pilot does not have the visual landing aid (ball) in sight.

Clara lineup. A pilot transmission indicating the pilot does not have a usable lineup reference.

command control. Acknowledgment that aircraft being controlled by data-link signals.

coupled. Aircraft automatic flight control system engaged and linked to data-link commands.

D

data-link address. Discrete identification assigned to data-link equipped aircraft.

NAVAIR 00-80T-105

data-link equipment. Automatic transmission device capable of very high data rate.

data-link monitor (DLM). Used by the final controller to observe data being sent to aircraft under PALS control.

DELTA. A signal given to hold and conserve fuel at an altitude and position appropriate to type aircraft and case recovery in effect.

DELTA switch. A signal given to an aircraft authorizing an airborne internal crew switch.

departure control. A control position in CATCC responsible for aircraft departures. This position is also responsible for monitoring the location and package status of tanker aircraft; the location of low-state aircraft and their fuel requirements.

Departure reference radial (DRR). A TACAN radial assignment by CATCC to which all squadron departure radials are referenced.

divert. An order for an aircraft to proceed and land at the field specified. This is a nonemergency situation.

E

eight nautical miles DME fix. A checkpoint in a CCA, normally located on the final bearing, 8 miles from the carrier. All jet and turboprop aircraft will pass through the 8-nm DME fix in level flight at an altitude of 1,200 feet, 250 KIAS, and will normally commence transition to the landing configuration.

emergency expected approach time (EEAT). The future time, assigned prior to launch, at which an aircraft is cleared to depart inbound or penetrate from a preassigned fix under lost communication conditions.

emergency marshal. A marshal established by CATCC and given to each pilot prior to launch with an altitude and an EEAT. The emergency marshal radial shall have a minimum of 30° separation from the primary marshal.

expected approach time (EAT). The future time at which an aircraft is cleared to depart inbound or penetrate from a preassigned fix. Aircraft depart and commence approach at assigned time if no further instructions are received.

F

final bearing. The magnetic bearing assigned by CATCC for final approach. It is an extension of the landing area centerline.

final control. A control position in CATCC responsible for control of aircraft on final approach during Case III until transfer of control to the LSO or the aircraft reaches approach weather minimums. Approach control retains overall responsibility for separation of aircraft.

Fleet Area Control and Surveillance Facility (FACSFAC). A U.S. Navy fixed, shore-based air traffic control facility. Designated to manage offshore and inland operating areas and other assigned airspace, including special use airspace. Provides joint-use scheduling and control of surface, subsurface, and airborne military platforms operating within and transiting to and from these areas. Administers services to support the coexistence of military government and nongovernment agencies consistent with national priorities.

flight level. Pressure altitude expressed in hundreds of feet determined by setting 29.92 in the aircraft pressure altimeter; that is, FL230 equals 23,000 feet pressure altitude.

FOX CORPEN. Ship's true heading during flight operations.

I

ICLS approach. Instrument Carrier Landing System. A precision approach in which precise and continuous position error and range information from the ILM and TACAN is displayed in an aircraft enabling a manually controlled precision approach to appropriate minimums.

inbound bearing. The magnetic heading assigned by CATCC to pilots descending directly to the carrier. It may be, but is not necessarily, the final bearing.

inbound heading. The magnetic heading assigned by CATCC that will ensure interception of the final bearing at a specific distance from the carrier.

independent landing monitor (ILM or bullseye). Provides glideslope and azimuth information with the ARA-63/SPN 41. The ILM components are the AN/SPN-41 (shipboard) or AN/TRN-28 (shore based), and the AN/ARA-63 or AN/ARN-138 (airborne).

integrated launch and recovery television system (ILARTS). A television system used to provide real-time imagery and recordings of aircraft during launch and recovery operations. It is comprised of two components: The pilot landing aid television (PLAT) system and the catapult aircraft hookup and launch (CAHAL) system.

intent to launch (ITL). A term associated with weapons, such as Harpoon/SLAM/JSOW, referring to the signal sent to activate and fire the weapon.

ITL weapon. A weapon, such as Harpoon/SLAM/JSOW, for which an intent to launch signal has been initiated and whose launch has subsequently been aborted by the aircrew or failed prior to separation of the weapon from the aircraft.

K

KILO report. A pilot coded report indicating aircraft mission readiness.

L

load report. A report given to marshal by the COD/VOD aircraft providing the numbers of passengers, VIP codes, mail, and cargo on board; also, any pertinent information for the CV, including fuel requirements and pilot name.

lock-on. A verbal report from the final controller when PALS radar acquires the aircraft and

commences tracking. Mode I/II equipped aircraft should receive ACL ready/lock-on discrete light.

M

marshal. A bearing, distance, and altitude fix designated by CATCC from which pilots will orient holding and from which initial approach will commence.

marshal control. A control position in CATCC responsible for providing control and arrival information to inbound aircraft until handed off to another controlling agency.

Mode I approach. A precision approach in which an aircraft is controlled automatically by the AN/SPN-42 or AN/SPN-46 to touchdown.

Mode IA approach. A precision approach in which an aircraft is controlled automatically by the AN/SPN-42 or AN/SPN-46 to 200 feet above and 1/2 nm from the touchdown point.

Mode II approach. A precision approach in which precise and continuous position error information from the AN/SPN-42/46 is displayed in an aircraft enabling a manually controlled precision approach to appropriate minimum.

Mode IID (flight director) approach. An enhanced Mode II approach in which pitch and roll guidance is transmitted to a HUD display to assist the pilot in the capture and maintenance of the glidepath and centerline to appropriate minimums.

Mode IIT approach. A Mode II training approach in which the pilot flies a Mode II approach while being provided with Mode III approach information.

Mode III approach. A precision approach in which a pilot is supplied position guidance information from the AN/SPN-42 or AN/SPN-46 by a final controller enabling a manually controlled precision approach to appropriate minimums.

monitor control. The monitoring of radar and radio channels for emergency transmissions.

N

needles. Precision instrument approach cockpit indications from (PALS) radar equipment.

nonprecision approach. Radar controlled approach or an approach flown by reference to navigation aids in which glideslope information is not available.

nonradar control. A form of air traffic control in which the pilot flies according to a published procedure or as prescribed by the controlling agency. Traffic separation is provided by the controlling agency, using frequent pilot position reports and modified separation criteria. This form of control is used only in case of emergency, when all shipboard air control radar is inoperative or, in the opinion of the CATCC officer, unusable.

O

operational commitment. A situation of such compelling urgency that failure to grant a deviation from established explosive safety criteria will have a deleterious impact on the mission readiness of naval forces.

P

PALS acquisition window. An area in space surrounding the glideslope and extended centerline of the landing area in which aircraft are acquired by the PALS radar.

platform. A point of 5,000 feet altitude in the approach pattern at which all jet and turboprop aircraft will decrease their rate of descent to not more than 2,000 feet per minute, continuing letdown to the 10-nm DME fix.

Popeye. A pilot coded report indicating aircraft flying in clouds or area of reduced visibility.

port holding pattern. The Case I jet and turboprop aircraft holding pattern is a left-hand, 5-mile maximum pattern tangent to the BRC or expected BRC with the ship in the 3-o'clock position of the

holding pattern. Altitude is assigned via landing order as established in ship/air wing doctrine.

positive control. A form of air traffic control in which the controlling agency has radar and radio contact with the aircraft being controlled and published approach or departure procedures are complied with, or where specific assignments regarding heading and altitude are issued by the controller. While altitude separation is provided by pilot maintaining assigned altitude, lateral and time separation is the responsibility of the air traffic controller. Speed changes may be directed by the air traffic controller.

precision approach. An approach in which azimuth, glideslope, and distance information are provided the pilot.

Precision approach and landing system (PALS). A system consisting of shipboard and aircraft components for all weather recovery of carrier-based aircraft.

R

ramp time (ready deck). Anticipated time specified by PriFly that the deck will be ready to recover aircraft and the first aircraft of a Case III recovery is expected to be at the ramp.

red light. The local time at which a helicopter will no longer be SAR capable and has approximately 30 minutes of flight time remaining.

retro report. A report given to COD aircraft by marshal providing offload information on passengers, mail, cargo, or any other pertinent information.

S

six nautical miles DME fix. A checkpoint in a CCA located on the final bearing 6 miles from the carrier through which all jet and turboprop aircraft will pass in level flight at an altitude of 1,200 feet in landing configuration. When necessary for traffic separation, turboprop aircraft may be instructed to

commence transition to landing configuration no later than the 6-nm DME fix.

spin. A signal given to one or more aircraft indicating a departure and reentry into the break. The command “Spin” may be issued by either the air officer or a flight leader.

spin pattern. A left-hand pattern employed for jet and turboprop aircraft to reentry the break during Case I or Case II recoveries. The pattern will be flown at 1,200 feet oriented on the BRC or expected BRC. The pattern will not exceed a distance of 3 nm from the ship.

starboard holding pattern. A right-hand racetrack pattern between 045° and 135° relative for COD aircraft and 045° and 110° relative for helicopters. COD aircraft 500 feet, 1,000 feet if approved by CV primary, and helicopters 300 feet or below.

T

ten-second discrete light. Illuminates approximately 10 seconds prior to touchdown, indicating deck motion compensation (DMC) is being transmitted from Mode I certified ships. Illuminates approximately 10 seconds prior to reaching minimums on ships certified only for Mode IA/II/IID.

three nautical miles DME fix. A checkpoint in a CCA on the final bearing 3 miles from the carrier through which all turboprop aircraft and helicopters will pass in a landing configuration.

U

uncoupling. Aircraft being disengaged from data link commands.

universal test message (UTM). Utilized to ensure proper operation of aircraft data link equipment.

W

weather criteria. Case I weather requires the ceiling to be no lower than 3,000 feet and not less than 5 nm visibility. Case II weather requires the lowest ceiling to be 1,000 feet or above and 5 nm visibility. Case III weather is any ceiling below 1,000 feet or a visibility less than 5 nm.

Z

ZIP LIP. A condition that may be prescribed for flight operations during daylight VMC conditions under which positive communications control is waived and radio transmissions between aircraft, pilots, and control agencies are held to the minimum necessary for safety of flight. The exception is COD aircraft, unless specifically noted in the overhead message.

LIST OF ABBREVIATIONS/ACRONYMS

A

ADF. Automatic direction finder.

ADIZ. Air defense identification zone.

AFCS. Automatic flight control system.

AFFF. Aqueous film forming foam.

AIMD. Aircraft intermediate maintenance department.

AOCC. Air operations control center.

APC. Approach power compensator.

ATO. Air transfer officer.

C

CAD. Cartridge-actuated device.

CAP. Combat air patrol.

CARQUALS. Carrier qualifications.

CATCC DAIR. Carrier air traffic control center direct altitude identity.

CCA. Carrier controlled approach.

CCP. Central charging panel.

CDC. Combat direction center.

COC. Catapult officer console.

COD. Carrier on-board delivery.

COMSEC. Communication security.

CQ. Carrier qualification.

CSV. Capacity selector valve.

CVIC. Carrier intelligence center.

D

DMC. Deck motion compensator.

DME. Distance measuring equipment.

E

EEFI. Essential elements of friendly information.

EOD. Explosive ordnance disposal.

ETE. Estimated time en route.

F

FOD. Foreign object damage.

G

GCI. Ground controlled intercept.

GPS. Global positioning system.

H

HAC. Helicopter aircraft commander.

HDC. Helicopter direction center.

HERO. Hazards of electromagnetic radiation to ordnance.

HUD. Heads-up display.

I

ICAO. International civil aviation organization.

ICCS. Integrated catapult control station.

ICLS. Instrument carrier landing system.

ICS. Internal communication system.

IFF. Identification friend or foe.

IFR. Instrument flight rules.

ILARTS. Integrated launch and recovery television system.

NAVAIR 00-80T-105

ILM. Independent landing monitor.

IMC. Instrument meteorological conditions.

INMARSAT. International maritime satellite.

■ **ITL.** Intent to launch.

J

JBD. Jet blast deflector.

L

LPH. Amphibious assault ship.

LSE. Landing signalman enlisted.

LSO. Landing signal officer.

M

MCC. Monitor control console.

MER. Multiple ejection rack.

MFFV. Mobile firefighting vehicle.

MOVLAS. Manually operated visual landing aid system.

MRC. Maintenance requirement card.

MSL. Mean sea level.

N

NAVAID. Navigation aid.

NFO. Naval flight officer.

NOTAM. Notice to airman.

NVG. Night vision goggle.

O

OLS. Optical landing system.

OPORD. Operation order.

OTC. Officer in tactical command.

P

PASE. Preloaded accessory suspension equipment.

PIM. Position and intended movement.

POTS. Plain old telephone system.

PRIFLY. Primary flight control.

R

RATS. Reduced arrestment thrust system.

S

SAR. Search and rescue.

SIF. Selective identification feature.

SIGINT. Signal intelligence.

SRC. Scheduled removal component.

T

TACAN. Tactical air navigation.

TALD. Tactical air-launched decoy.

TAU. Twin agent unit.

TER. Triple ejection rack.

U

USW. Undersea warfare.

UTM. Universal test message.

V

VERTREP. Vertical replenishment.

VMC. Visual meteorological conditions.

VOD. Vertical onboard delivery.

W

WOD. Wind overdeck.

PREFACE

SCOPE

The NATOPS Flight Manual is issued by the authority of the Chief of Naval Operations and under the direction of Commander, Naval Air Systems Command in conjunction with the Naval Air Training and Operating Procedures Standardization (NATOPS) Program. This manual contains information on all aircraft systems, performance data, and operating procedures required for safe and effective operations. However, it is not a substitute for sound judgment. Compound emergencies, available facilities, adverse weather or terrain, or considerations affecting the lives and property of others may require modification of the procedures contained herein. Read this manual from cover to cover. It is your responsibility to have a complete knowledge of its contents.

HOW TO GET COPIES

Automatic Distribution (with Updates)

This publication and changes to it are automatically sent to activities that are established on the Automatic Distribution Requirements List (ADRL) maintained by Naval Air Technical Data and Engineering Service Command, in San Diego, CA. If there is continuing need for this publication, each activity's Central Technical Publication Librarian must send a revised ADRL report on floppy disk to Naval Air Technical Data and Engineering Service Command. If an activity does not have a library, send a letter to the Commanding Officer, Naval Air Technical Data and Engineering Service Command, Naval Aviation Depot North Island, Bldg. 90, Code 3.3A, P.O. Box 357031, San Diego, CA 92135-7031, requesting assignments of a distribution account number (if necessary) and automatic mailing of future issues of the publications needed.

Note

The ADRL floppy disk can be used only to place an activity on the mailing list for automatic distribution of future issues of the publication. It cannot be used to make one-time orders of publications from current stock.

Once established on automatic distribution for this or any other NAVAIR technical publication, an activity must submit an ADRL report on floppy disk at least once every 12 months to update or confirm their automatic distribution requirements.

Note

Activities not submitting an ADRL report on floppy disk for more than 12 months may be dropped from distribution of all NAVAIR technical publications.

UPDATING THE MANUAL

To ensure that the manual contains the latest procedures and information, NATOPS review conferences are held in accordance with OPNAVINST 3710.7 series.

CHANGE RECOMMENDATIONS

Recommended changes to this manual or other NATOPS publications may be submitted by anyone in accordance with OPNAVINST 3710.7 series.

Routine change recommendations are submitted directly to the Model Manager on OPNAV Form 3710/6 (4-90) shown herein. The address of the Model Manager of this aircraft is:

OIC US NAVY LSO School
1680 Tomcat Boulevard
Suite 100
Virginia Beach, VA 23460-2189
Email address: LSOschool@nasoceana.navy.mil

Change recommendations of an URGENT nature (safety of flight, etc.), should be submitted directly to the NATOPS Advisory Group Member in the chain of command by priority message.

YOUR RESPONSIBILITY

NATOPS Flight Manuals are kept current through an active manual change program. Any corrections, additions, or constructive suggestions for improvement of its content should be submitted by routine or urgent change recommendation, as appropriate at once.

NATOPS FLIGHT MANUAL INTERIM CHANGES

Flight Manual Interim Changes are changes or corrections to the NATOPS Flight Manuals promulgated by CNO or NAVAIRSYSCOM. Interim Changes are issued either as printed pages, or as a naval message. The Interim Change Summary page is provided as a record of all interim changes. Upon receipt of a change or revision, the custodian of the manual should check the updated Interim Change Summary to ascertain that all outstanding interim changes have been either incorporated or canceled; those not incorporated shall be recorded as outstanding in the section provided.

CHANGE SYMBOLS

Revised text is indicated by a black vertical line in either margin of the page, like the one printed next to this paragraph. The change symbol shows where there has been a change. The change might be material added or information restated. A change symbol in the margin by the chapter number and title indicates a new or completely revised chapter.

WARNINGS, CAUTIONS, AND NOTES

The following definitions apply to WARNINGS, CAUTIONS, and Notes found throughout the manual.



An operating procedure, practice, or condition, etc., that may result in injury or death, if not carefully observed or followed.



An operating procedure, practice, or condition, etc., that may result in damage to equipment, if not carefully observed or followed.

Note

An operating procedure, practice, or condition, etc., that is essential to emphasize.

WORDING

The concept of word usage and intended meaning adhered to in preparing this Manual is as follows:

1. “Shall” has been used only when application of a procedure is mandatory.
2. “Should” has been used only when application of a procedure is recommended.
3. “May” and “need not” have been used only when application of a procedure is optional.
4. “Will” has been used only to indicate futurity, never to indicate any degree of requirement for application of a procedure.

NATOPS/TACTICAL CHANGE RECOMMENDATION
 OPNAV 3710/6 (4-90) S/N 0107-LF-982-6400

DATE _____

TO BE FILLED IN BY ORIGINATOR AND FORWARDED TO MODEL MANAGER

FROM (originator)	Unit
TO (Model Manager)	Unit

Complete Name of Manual/Checklist	Revision Date	Change Date	Section/Chapter	Page	Paragraph
-----------------------------------	---------------	-------------	-----------------	------	-----------

Recommendation (be specific)

CHECK IF CONTINUED ON BACK

Justification

Signature	Rank	Title
-----------	------	-------

Address of Unit or Command

TO BE FILLED IN BY MODEL MANAGER (Return to Originator)

FROM	DATE
------	------

TO

REFERENCE

(a) Your Change Recommendation Dated _____

Your change recommendation dated _____ is acknowledged. It will be held for action of the review conference planned for _____ to be held at _____

Your change recommendation is reclassified URGENT and forwarded for approval to _____ by my DTG _____

/S/ _____ MODEL MANAGER	_____ AIRCRAFT
-------------------------	----------------

CHAPTER 1

Predeployment

1.1 TRAINING REQUIREMENTS

The air wing commander shall coordinate all squadron predeployment training requirements with the ship.

Squadron commanders shall ensure all personnel complete the lecture syllabus outlined below prior to initial deployment. This applies equally to those squadrons/detachments that embark/operate for short-term workups, CQ, transits, and so forth. These lectures need not be repeated before every deployment; however, squadron commanders are responsible for providing refresher training as required for the safety of personnel and equipment. Ship's company personnel should assist in this training; however, when this is not feasible, the most qualified squadron personnel shall be utilized.

The air officer shall ensure in addition to the formal training required by type commanders, air department personnel receive training as necessary to acquaint them with the peculiarities of the specific aircraft models being deployed. Particular emphasis shall be placed on special aircraft handling requirements, flightcrew rescue procedures, specific aircraft firefighting procedures, and aircraft salvage procedure. In addition, Crash and Salvage personnel shall conduct a face-to-face briefing with squadron aircrew personnel, communicating what they expect during an emergency egress.

Note

All personnel assigned flight deck working stations shall first complete Flight Deck Familiarization PQS (NAVEDTRA 43426-0 Series).

1.2 ADDITIONAL REQUIREMENTS

The commanding officer of each CV shall promulgate and distribute, as appropriate, an [air operations](#) manual containing standardized air traffic control procedures covering all normal evolutions as

well as common emergencies in support of and supplementary to the procedures contained in this manual, including but not limited to the following subjects: communications control; plane guard helicopter/ship; [marshal](#), arrival, and departure procedures; [zip lip](#); procedures during shipboard systems failures; hot refueling, and standard arming and dearming areas.

As a minimum, the air operations manual shall be reviewed annually to ensure the subject matter is pertinent and up to date. New or revised air operations manuals shall be forwarded to the appropriate TYCOM, COMCARGRU/COMCRUDESGRU, COMCARAIRWING, CARAIRWING, and COMNAVSAFECEN (Code 114). Distribution to other units conducting air operations activities with the CV is encouraged.

The air wing commander shall promulgate and distribute, as appropriate, OPORD containing but not limited to the following: air wing organization, general operating procedures, VMC rendezvous, air wing recovery order and altitude assignments, tanker patterns and procedures, [zip lip](#), EMCON procedures, rainmaker, Hawkeye controlled approach procedures, deck launch intercept, and lost communications/NAVAID procedures.

Squadron commanders shall submit prior to deployment a complete list of aircraft being deployed. The list shall include side numbers, [PALS](#) addresses, basic weights, certification that all aircraft are FOD free, verification that all aircraft hoisting points/access panels are readily accessible and functional, and any peculiarities in configuration that will affect handling, ordnance loading, or mission capability. Squadron commanders shall also submit a list of pilots and individual requirements for initial and refresher carrier qualification.

Each squadron commander, when embarked, shall provide PriFly control and [CATCC](#) with a current NATOPS flight manual and pocket checklist for each aircraft under his command.

NAVAIR 00-80T-105

The air officer shall ensure the availability of appropriate aircraft handling equipment, including aircraft hoisting slings, for each model aircraft assigned.

The AIMD officer shall ensure the availability of appropriate special aircraft maintenance equipment for each model aircraft assigned.

The air operations officer shall ensure accurate **bingo** fuel and fouled deck endurance data are available for each model aircraft being deployed. He shall also ensure CATCC personnel are proficient in the interpretation of these data.

The commanding officer shall ensure all personnel assigned duties on CV flight decks comply with the required physical standards contained in the Manual of the Medical Department, U.S. Navy.

1.3 PREDEPLOYMENT LECTURE SYLLABUS

1.3.1 All Personnel.

1. Duties and responsibilities during flight quarters, general quarters, fire quarters, abandon ship, man overboard, and other general drills
2. Firefighting and damage control shipboard indoctrination
3. Duties and responsibilities under HERO and EMCON conditions
4. Shipboard safety and smoking regulations
5. Watch standing peculiar to shipboard operations
6. Flight and hangar deck safety precautions
7. Proper use and care of flight deck floatation vest

8. Water survival and rescue procedures.

1.3.2 Plane Captains.

1. Aircraft handling procedures
2. Flight and hangar deck safety precautions
3. Responsibilities during launch and recovery
4. Aircraft tiedown requirements and techniques.

1.3.3 Maintenance Personnel.

1. Shipboard maintenance procedures
2. Special shipboard safety precautions.

1.3.4 Flight Crewmembers.

1. Flight and hangar deck safety precautions
2. Launching procedures and signals
3. Arrested landing procedures and signals
4. Aircraft control doctrine and procedures
5. Emergency procedures peculiar to carrier operations
6. Special procedures for Case III
7. Landing aids/PALS
8. Communications
9. Flight deck configuration and lighting.

1.3.5 Ordnance Personnel.

1. Shipboard weapon handling procedures
2. Shipboard ordnance safety instructions.

CHAPTER 2

Preparing for Flight Operations

2.1 THE AIR PLAN

To obtain maximum efficiency from personnel and equipment, carrier air operations must be precisely scheduled in every respect. Air operations and strike operations are the coordinating and scheduling agencies for all flight operations. The strike operations officer will collect all required flight information for preparation of the daily air plan that will be submitted to the operations officer via the air operations officer, for approval and signature.

In order for strike operations to prepare an air plan that is within the capabilities of the air wing and all supporting activities, the following must be reported on a regular basis:

1. An up-to-date inventory of aviation ordnance on board and available for the next day's operation.
2. The status of all embarked aircraft. This report shall be delivered to the bridge, flag bridge, flag operations, air operations, and the air department. In addition to current aircraft status, the report should include expected changes in status and test flight requirements for the following day.
3. Air intelligence information concerning the next day's operation.

Normally, the air plan will be distributed on the evening before the scheduled operations. When the air plan is delayed, the strike operations watch officer shall provide advance information to allow preparations for the first flights. As a minimum, air ops, flight deck control, PriFly, the air department duty officer, all ready rooms, CVIC, the ship's ordnance handling officer, and CDC shall be advised of the following:

1. Launch times
2. Mission
3. Flight composition

4. Fuel requirements

5. Ordnance loading.

The air plan shall include the following:

1. Event number
2. Launch time
3. Recovery time
4. Mission
5. Number and model of aircraft, including spares
6. Squadron and radio call
7. Total sorties
8. Sunrise, sunset, moonrise, moonset, phase
9. Date
10. Fuel
11. Alert aircraft
12. Logistics aircraft
13. Tactical frequencies
14. Notes as required. Notes shall include the following:
 - a. EMCON/ZIP LIP conditions
 - b. Ready deck schedule
 - c. Any other information required including restrictions or hazards to flight.

Upon receipt of the daily air plan, each squadron shall prepare and distribute its flight schedule as required. This schedule shall designate pilots, radio calls, and the mission for each flight assigned. It is the

responsibility of the aircraft handling officer to ensure strict conformance to the air plan.

2.1.1 The Ordnance Load Plan. Strike operations shall prepare an ordnance load plan that will be utilized as a supplement to the air plan for aircraft ordnance loads. No changes will be made to the ordnance load plan without approval by the strike operations officer. It is the responsibility of the aircraft handling officer to ensure strict conformance to the ordnance load plan.

2.2 FLIGHT QUARTER STATIONS

Flight quarter stations shall be manned when directed and as prescribed in the ship's watch quarter and station bill. Some evolutions may not require that all flight quarter stations be manned. On such occasions, specific instructions should be issued at the time the word is passed to set flight quarters (for example, "Flight quarters for respot," "Flight quarters for helicopter operations," and so forth).

All personnel assigned working stations on the flight or hangar decks, catapult, arresting gear, aviation fuels, and ordnance spaces shall wear flight deck safety shoes. Those personnel assigned flight quarter stations on or above the hangar deck shall wear jerseys as prescribed in **Figure 2-1**. Flight deck personnel shall wear the HGU-24/P or HGU-25/P cranial impact helmet or equivalent. Additionally, all flight deck personnel shall wear and maintain the following items in accordance with the applicable MRC cards: goggles, sound attenuators, floatation gear, dye marker, and adequately secured whistle and strobe light. All personnel working on the hangar deck whose duties require them to work on deck-edge elevators shall wear floatation gear, dye marker, and adequately secured whistle and strobe light. During night flight operations, only those signal wands prescribed in **Figure 2-2** shall be used. All other personnel use flashlights. A blue filter shall be used. During flight quarters, individuals wearing improper clothing shall not be permitted on the flight deck without the express consent of the aircraft handling officer.

2.2.1 Aqueous Film Forming Foam System and Mobile Firefighting Equipment. The guidelines for manning and disposition of the AFFF system and mobile firefighting equipment shall be observed as outlined in NAVAIR 00-80R-14, U.S. Navy Aircraft Firefighting and Rescue Manual.

2.2.2 Preliminary Procedures — CATCC. One and one-half hours before scheduled flight operations, CATCC shall be manned and the following checkoff list executed, commensurate with the EMCON plan in effect. Immediately report all discrepancies for appropriate action and advise the operations officer and commanding officer if equipment failure will affect air operations.

1. Check all radio/intercom and sound powered equipment including proper patch panel setup. Check frequency assignment.
2. Check all CCA/Air Ops equipment and NAVAIDS for proper operation.
3. Ensure proper magnetic variation is set in TACAN and CATCC DAIR.
4. Update CATCC DAIR video maps and fixed data stores as required. Check ship's position for accuracy.
5. Synchronize clocks using GPS time hack.
6. Establish communications with shore activities on INMARSAT, POTS, or ATCOM as applicable. Refer to OPNAVINST 3710.7 series.
7. Obtain weather and upper winds for the operating area and shore stations within aircraft range. Advise meteorology of any special requirements for weather information during the day. Ensure ship's weather observation will be taken at least each 30 minutes during flight operations.
8. Advise the operations officer, bridge, and flag plot if aircraft availability will seriously limit scheduled air operations.

PERSONNEL	HELMET	JERSEY/ FLOATATION VEST	SYMBOLS, FRONT AND BACK
Aircraft handling crew and chock men	Blue	Blue	Crew number
Aircraft handling officers and plane directors	Yellow (Notes 1-5) as needed)	Yellow	Billet title — crew number
Arresting gear crew	Green	Green	A
Aviation fuel crew	Purple	Purple	F
Cargo handling personnel	White	Green	“Supply”/“POSTAL” as appropriate
Catapult and arresting gear officers	Green	Yellow	Billet title
Catapult crew	Green	Green	C
Catapult/AG QA	Green	White	ALRE QA
Catapult safety observer (ICCS)	Green	(Note 6)	Billet title
Crash and salvage crews	Red	Red	Crash/Salvage
Elevator operators	White	Blue	E
Explosive ordnance disposal	Red	Red	“EOD” in black
GSE troubleshooter	Green	Green	“GSE”
Helicopter LSE	Red	Green	H
Helicopter plane captain	Red	Brown	H
Hook runner	Green	Green	A
JBD safety observer	Green	Green/White	JBD safety
Landing signal officer	None	White	LSO
Leading petty officers:			
Line	Green	Brown	Squadron designator and “Line CPO”
Maintenance	Green	Green	Squadron designator plus “Maint. CPO”
Quality assurance	Brown	White	Squadron designator and “QA”
Squadron plane inspector	Green	White	Black and white checkerboard pattern and squadron designator
LOX crew	White	White	LOX
Maintenance crews	Green	Green	Black stripe and squadron designator
Medical	White	White	Red cross
Messengers and telephone talkers	White	Blue	T
Ordnance	Red	Red	3-inch black stripe and squadron designator/ship’s billet title
Ordnance CAG Arm/De-arm	Red/Red	Red/Red	3-inch black stripe and the letters “CA” in 6-inch white reflective material
Ordnance QA	White	(Note 8)	Squadron designator and “ORDNANCE QA/SAFETY”
Photographers	Green	Green	P

Figure 2-1. Authorized Flight Quarters (Sheet 1 of 2)

PERSONNEL	HELMET	JERSEY/ FLOATATION VEST	SYMBOLS, FRONT AND BACK
Plane captains	Brown	Brown	Squadron designator
Safety	White	White	"SAFETY"
Supply VERTREP coordinator	White	Green	"SUPPLY COORDINATOR"
Tractor driver	Blue	Blue	Tractor
Tractor King	Blue	(Note 7)	TK
Transfer officer	White	White	"TRANSFER OFFICER"
<p>Notes:</p> <ol style="list-style-type: none"> 1. Only personnel charged with the actual control or direction of aircraft movements on the flight or hangar decks shall wear yellow jerseys. Personnel in charge of a detail, such as aviation fuels, ordnance, and maintenance, shall wear a helmet and jersey corresponding in color to that of their respective detail and with their billet title on the jersey and floatation vest. 2. Helmets for all personnel shall be marked with a 6-inch square (or equivalent) of white reflective tape on the back shell and a 3-inch by 6-inch (or equivalent) of white reflective tape on the front shell. Landing signal officers are not required to wear helmets or sound attenuators when engaged in aircraft control. Helmets shall have a 2-inch piece of velcro on the left side of the front shell and velcro on the survival light. 3. Three reflective international orange stripes, 1-inch wide, evenly spaced, shall run fore and aft on top of the white reflective tape. <ol style="list-style-type: none"> a. All air department officers b. Air department chief petty officers and leading petty officers c. EOD team members d. All ordnance officers and gunners e. Ordnance handling officer and gunner. 4. Helmets for all personnel who have not completed flight deck observer qualification shall be marked (front and rear) with a "T" using 1-inch wide blue reflective tape over the existing reflective tape (front minimum 2-inch tall, rear minimum 3-inch tall lettering). 5. Helmets for all aircraft directors under instruction shall be marked (front and rear) with a "U/I" using a 1-inch wide blue reflective tape evenly spaced over the existing reflective tape (front minimum 2-inch tall, rear minimum 3-inch tall lettering). 6. ICCS green jersey/yellow flotation vest. 7. Yellow jersey/blue flotation vest. 8. White jersey/red flotation vest. 			

Figure 2-1. Authorized Flight Quarters (Sheet 2 of 2)

9. Obtain launch and recovery PIM and check its relation to warning areas and controlled airspace. Coordinate potential conflicts with shore activities/FACSFAC. Ensure hot areas are posted and briefed. Brief any potential conflicts with the bridge and CDC.
10. Check daily message traffic (overhead message and COD PIM, flight plans for flyoff aircraft, OPAREA synopsis, etc.) that will affect flight operations.
11. Check the air plan for changes and notify stations concerned.
12. Obtain card of the day.
13. Check all status boards for accuracy and completeness of information.
14. Obtain **divert** field information, including NOTAMS, weather and airfield availability.
15. Brief with air operations officer for special requirements.

2.2.3 Preliminary Procedures — Air Officer.

When flight quarters is sounded, the air officer shall ensure the following:

1. Procedures prescribed in applicable bulletins and instructions for inspection and preparation for operation of the catapults, arresting gear, visual landing aids, **ILARTS**, elevators, aviation fuel system, and crash and firefighting equipment are meticulously followed. Discrepancies shall be reported to the bridge as soon as they are detected. A decision to conduct flight operations when discrepancies are known to exist in any of the above equipment shall be made only by the commanding officer.
2. A FOD walkdown is conducted prior to flight operations and as required by the air officer during flight operations.

PERSONNEL	COLOR	NO	TYPE*
Aviation Fuels	Amber	1	Stubby
Bow Safety	Red	1	Standard
	Green	1	Standard
Catapult Hookup Petty Officer	White	1	Stubby
Catapult Safety Observer (ICCS)	Red	1	Standard
	Green	1	Standard
Center Deck Operator (Topside)	White	1	Stubby
Deck Edge (Arresting Gear)	Red	1	Standard
	Green	1	Stubby
Deck Edge (Catapults)	Red	1	Standard
Flight Deck Officer and Aircraft Directors	Amber	2	Standard
Hook Runner	Red	1	Stubby
JBD Safety	White	1	Stubby
Launching and Arresting Gear Officer/Helicopter LSE/LSO	Red	1	Standard
	Green	1	Standard
LSO Platform Talker (Arresting Gear)	Red	1	Standard
	Green	1	Standard
Ordnance Arming Crew	Red	1	Stubby Banded **
Ordnance Arming/Safety Supervisor	Red	2	Standard Banded ***
Plane Captain	Blue	2	Standard
Squadron Aircraft Inspector	Blue	1	Stubby
Weightboard Operator	White		Stubby
* Standard and stubby denote cone shape. Standard denotes full length cones; stubby is a modified cone providing 3 inches of lighted cone. Any suitable battery and switch housing is authorized if cone is brightly lighted. All signal wands/flashlights shall be equipped with heat-shrinkable sleeving to prevent possible cone separation.			
** One 3/4-inch band on the cone (plastic electricians tape is recommended).			
*** Two 3/4-inch bands spaced equidistant on the cone (plastic electricians tape is recommended).			

Figure 2-2. Standard Signal Wands

2.3 BRIEFING

It is the responsibility of squadron or unit commanders to ensure all flightcrews have been properly briefed and have sufficient information to complete the assigned mission. Briefing checkoff lists shall be used as required by applicable aircraft NATOPS flight manuals. Each briefing must include EMCON procedures, if applicable, and procedures to be followed in the event of communication or NAVAID failure.

Air ops shall provide the following prelaunch briefing information 2-1/2 hours prior to each event:

1. Launch and recovery times
2. Launch and recovery PIM
3. NAVAID status and frequencies
4. Ship's weather
5. Weather at [bingo](#) fields and en route
6. Emergency data
 - a. Bearing and distance to nearest land
 - b. Bearing and distance to nearest suitable landing field
 - c. NAVAIDs, frequencies, and facilities at nearest field
 - d. Ready carrier-call, frequencies, NAVAIDs, and PIM
 - e. Expected [final bearing](#)
 - f. [Emergency marshal](#) fixes/altitudes/approach times.
7. Air traffic control data
 - a. Departure/rendezvous radials
 - b. Departure frequency and IFF/SIF mode and code
 - c. Special procedures for ZIP LIP/EMCON conditions (if in effect).

8. Any restrictions or hazards to flight
9. Pertinent information not included in the air plan.

CATCC shall provide to all aircraft not embarked in the ship, but engaged in any support operations (COD, VOD, etc.) that require them to recover aboard and launch again, all applicable items in the CATCC provided briefing information listed above.

2.4 FLIGHT PLANS AND ADVISORIES

The requirements for filing flight plans and advisories vary with each operating area and are contained in the flight information publications (FLIP) and fleet operating directives. As a rule, flight plans will be required for flights that:

1. Terminate ashore
2. Proceed across ADIZ boundaries and are not covered by a flight advisory
3. Proceed over land.

Flight advisories shall be filed for flights within ADIZ boundaries by all aircraft that will land back on board ship and are not covered by a flight plan. Squadrons shall file flight plans (DD175/DD1801) with CATCC to meet time requirements established by applicable operating area manuals or ICAO guidelines.

2.4.1 Close Proximity Operations. During concurrent flight operations by two or more CVs/MCSs/ LHAs/LHDs, or concurrent operations between a CV/MCS/LHA/LHD and other aviation-capable ships (fixed wing or helicopter), each ship should remain in its assigned disposition in order to reduce air traffic coordination problems. CATCC/AOCC or HDC must closely monitor and coordinate flight patterns to avoid mutual interference. Prelaunch procedures shall include exchange of air plans and prelaunch notification by aviation-capable ships and acknowledgment by the CV/MCS/LHA/LHD prior to any flight operations within 10 nm of the CV/MCS/LHA/LHD.

Note

Unscheduled launches or recoveries that are caused by emergency or operational necessity are permissible, but must be

coordinated with the OTC as soon as possible because of the inherent danger of combined flight operations.

2.5 CHANGES IN PILOT OR AIRCRAFT ASSIGNMENTS

Any last-minute changes in pilot or aircraft assignments must be relayed to CATCC and PriFly as soon as the change occurs.

2.6 AIR TRANSFER OFFICER

The ATO is responsible to the air operations officer for the safe and orderly flow of passengers, mail, and cargo on and off carriers by aircraft. In addition to the duties delineated in COMNAVAIRLANT/COMNAVAIRPACINT 3100.4 (air department standard operating procedures), the ATO shall be responsible for the following:

1. Conduct passenger preflight briefing to include the following:
 - a. Flight deck precautions
 - b. Primary and alternate routes from loading office to aircraft
 - c. Personal survival equipment and its use
 - d. Aircraft ditching and emergency egress stations.
2. Ensure personnel transiting the flight deck do not offer any FOD hazard and they are escorted with the highest regard for personal safety.
3. Be familiar with load capacities/restrictions, survival equipment carried, and emergency escape procedures for all aircraft types expected on board for logistic purposes. Inspect all cargo prior to loading and ensure hazardous material is certified by qualified personnel in accordance with NAVSUP 505 for shipping.
4. Ensure passengers are provided with proper cranial helmet, with goggles attached, and flotation equipment.

5. Provide a detailed mission requirement card to helicopters performing logistic missions. The card shall contain the following minimum information:
 - a. Order of ships to be visited
 - b. Ship name(s), hull number(s), call sign(s), NAVAID(s)
 - c. Expected bearing and distance to each ship (from carrier)
 - d. Pertinent radio frequencies for ships visited
 - e. Anticipated number of passengers to be delivered/picked up from each ship
 - f. Weight and description of cargo being delivered/picked up from each ship
 - g. Landing deck availability at each ship to be visited
 - h. HIFR capability at each ship to be visited.

Note

If original flight is to be extended, CATCC shall, where appropriate, update mission requirement card information as outlined above.

6. Be familiar with the current OPNAVINST 4630.25 regarding passenger priority.
7. Ensure proper personnel, equipment, and material are positioned to facilitate rapid offload/ onload of COD/VOD aircraft to minimize on-deck time and lessen impact on normal flight deck operations.
8. Ensure all personnel under ATO supervision (i.e., working parties) complete Flight Deck Familiarization PQS (NAVEDTRA 43426-0).

2.7 PASSENGER TRANSFERS

All passenger transfers shall be conducted IAW OPNAVINST 3710.7 series.

CHAPTER 3

Air Traffic Control Doctrine

3.1 RESPONSIBILITIES

3.1.1 Operations Officer. As defined by Navy regulations, the operations officer shall be responsible for the control of airborne aircraft except when control is assigned to other authority. This control refers to all airborne operations not incidental to the actual launch or recovery of aircraft.

3.1.2 Air Operations Officer. The air operations officer is responsible to the operations officer for coordination of all matters pertaining to flight operations, the proper functioning of the CATCC and shall determine the type of approach and required degree of control.

3.1.3 Air Officer. The air officer determines the case launch and/or recovery. The air officer is also responsible for visual control of all aircraft operating in the [carrier control zone](#). Under Case I and II conditions, this responsibility may be extended beyond the carrier control zone to include all aircraft that have been switched to air officer's control frequency. For special operations such as bombing a sled or air demonstrations, the air officer may exercise control outside of the carrier control zone. Additionally, the air officer is the carrier control zone clearing authority. Agents desiring to operate aircraft within the control zone must obtain the air officer's approval prior to entry. This clearance shall include the following:

1. Operating instructions as required for avoiding other traffic
2. Information concerning hazardous conditions
3. Altitude and distance limitations to which aircraft may be operated.

3.1.4 Landing Signal Officer. The LSO, under supervision of the air officer, is responsible for the visual control of aircraft in the terminal phase of the approach immediately prior to landing. LSO specific

responsibilities are delineated in the LSO NATOPS Manual (NAVAIR 00-80T-104).

3.1.5 Landing Signalman Enlisted. The LSE, under the supervision of the air officer, is to ensure helicopters, on signal, are safely started, engaged, launched, recovered, and shut down. The LSE receives his directions from PriFly via light signals and/or two-way flight deck communications. It is his responsibility to ensure all tiedowns are removed prior to lift-off and that the aircraft is properly secured after landing. All signals given by the LSE are advisory with the exception of the "waveoff" and "hold," which in all cases are mandatory. During vertical replenishment operations, the LSE directs the helicopter over the deck and provides signals for the delivery and hookup of cargo. Ensure LSE and Army aircrews are familiar with engagement/disengagement procedures of rotors, prior to recovery/launch operations.

3.1.6 Pilots. As directed by OPNAVINST 3710.7 series, the pilot is responsible for the safe and orderly conduct of the flight. The success of carrier operations largely depends upon his knowledge of and adherence to the procedures contained herein. Any necessary deviation from these procedures or from control instructions shall be reported to the controlling agency immediately so that allowances can be made.

3.1.7 Combat Direction Center Officer. The CDC officer is responsible for mission control of aircraft assigned to him. This includes providing separation from other aircraft operations in the vicinity of the carrier and ensuring intercept/mission controllers know the basic procedures for air traffic control. Additionally, he shall ensure these controllers know their responsibility for traffic advisories to aircraft operating in visual conditions and for safe separation of aircraft operating in instrument conditions. Upon request, he shall provide information concerning areas of special operations, such as air-to-surface weapon drops and air-to-air missile shoots.

3.2 CONTROL CRITERIA

Weather in the carrier control zone is the most prominent factor affecting the type of departure and/or recovery. There are three types of departure and recovery operations, which are referred to as Case I, Case II, and Case III.

The air officer, unless otherwise specified by higher authority, determines what case launch and/or recovery will be exercised using the following weather minimums:

Case I: When it is anticipated that flights will not encounter instrument conditions during daytime departures, recoveries, and the ceiling and visibility in the carrier control zone are no lower than 3,000 feet and 5 nm respectively.

Case II: When it is anticipated that flights may encounter instrument conditions during a daytime departure or recovery, and the ceiling and visibility in the carrier control zone are no lower than 1,000 feet and 5 nm respectively.

Case III: When it is anticipated that flights will encounter instrument conditions during a departure or recovery because the ceiling or visibility in the carrier control zone are lower than 1,000 feet and 5 nm respectively; or a nighttime departure or recovery (one-half hour after sunset and one-half hour before sunrise).

3.2.1 Degrees of Control

The four degrees of control are positive, advisory, monitor, and nonradar control.

3.2.1.1 Positive Control. This control shall be utilized under the following conditions:

1. Ceiling of:
 - a. Less than 1,000 feet for fixed-wing aircraft
 - b. Less than 500 feet for helicopter operations.
2. Forward flight visibility of:
 - a. Less than 5 miles for fixed-wing operations
 - b. One mile or less for helicopter operations.

3. All flight operations between one-half hour after sunset and one-half hour before sunrise except as modified by the OTC or carrier commanding officer.
4. During mandatory letdown in thunderstorm areas.
5. In other situations where supervisory personnel can anticipate weather phenomena that might cause difficulty to pilots.

3.2.1.2 Advisory Control. This control shall be utilized when the traffic density in an operating area requires a higher degree of control for safety of flight than required under visual flight rules. Advisory control is normally limited to VMC weather conditions and is recommended for all operations in or adjacent to oceanic control areas or routes. Traffic separation is the responsibility of the individual pilot with assistance provided by the controlling agency.

3.2.1.3 Monitor Control. This control shall be utilized only when aircraft are operating VMC outside controlled airspace and the responsibility for separation from other traffic can be safely assumed by the pilot.

3.2.1.4 Nonradar Control. This control shall be used when shipboard radar is inoperative or so degraded as to be inadequate to provide radar separation of air traffic under conditions normally requiring positive control. The decision to attempt control of aircraft at night or in instrument flight conditions must be made with careful consideration of such factors as the following:

1. Actual meteorological conditions
2. Degree of radar degradation
3. Expected duration of radar degradation
4. Fuel states and tanker fuel available for delays
5. Divert field considerations
6. Operational requirement
7. Departure/recovery in progress at the time a nonradar environment develops
8. Availability of other surface or airborne platforms to provide radar traffic separation and approach information.

3.2.2 Electronic Emission Control. The operations officer shall be responsible for EMCON in accordance with NWP 16, NWP 10-1-40, effective operation orders, and other governing directives. It may be necessary to develop special procedures for performing the following operations during EMCON conditions:

1. Aircraft handling
2. Launch
3. Departure
4. Mission
5. Arrival
6. Recovery
7. Maintenance.

COD aircraft will attempt to establish communications en route prior to arriving on station. If no radio contact is made the COD will return to base.

Detailed briefings covering responsibilities and procedures shall be conducted prior to operating under EMCON conditions. All flight crewmembers, controllers, aircraft handling personnel, and flight deck ordnance coordinators shall attend such briefings and familiarize themselves with all procedures within their area of responsibility. Overhead messages shall include applicable EMCON instructions.

The operations officer shall be responsible for setting the proper HERO conditions for control of radar and radio emissions while handling ordnance susceptible to RF energy. The air officer shall establish procedures for alerting flight deck ordnance personnel when the appropriate HERO conditions have been set.

3.3 SEPARATION CRITERIA

The following separation standards shall be utilized for aircraft under positive control. These restrictions do not apply to tactical maneuvers such as air intercept, rendezvous, and close USW action.

3.3.1 Lateral Separation.

1. The following separation standards apply to aircraft controlled by designated air search radars that rotate in excess of 7 rpm.
 - a. Aircraft operating at 50 miles or more from the monitoring antenna shall be separated by a minimum of 5 miles.
 - b. Aircraft operating less than 50 miles from the monitoring antenna shall be separated by a minimum of 3 miles.
 - c. Aircraft on a designated approach or established downwind and inside of 12 miles shall be separated by a minimum of 2 miles. Aircraft established on final within 5 miles shall be separated a minimum of 1-1/2 miles.

Note

Air search radars that rotate in excess of 7 rpm are the only radars acceptable for an ASR approach.

2. Aircraft provided positive control with all other radars shall be separated by a minimum of 5 miles.
3. Aircraft provided nonradar control, utilizing a published approach, should be separated by 2 minutes (5 miles separation when using DME).

3.3.2 Vertical Separation.

1. Jet and turbopropeller (turboprop) aircraft operating at altitudes up to and including FL 290 shall be separated by 1,000 feet.
2. Vertical separation may be reduced to 800 feet when inside of 12 nm.
3. Aircraft operating above FL 290 shall be separated by 2,000 feet.

Note

Carrier-based aircraft shall fly MSL altitudes below 18,000 feet MSL and **flight levels** at and above 18,000 feet MSL unless regional supplementary procedures, as published in FLIP Planning, dictate otherwise.

4. Helicopters shall be separated by 500 feet.

3.4 COMMUNICATION CONTROL

All aircraft are considered under positive communication control while operating at sea unless otherwise directed. Pilots shall not shift frequencies without notifying and/or obtaining permission from the controlling agency. Communication procedure during ZIP LIP/EMCON conditions shall be specified during preflight briefing.

3.4.1 Control of Radio Circuits. Control of radio circuits shall be exercised as follows:

3.4.1.1 CATCC.

1. Primary control of ship-shore air traffic control administrative frequencies
2. Primary control of assigned CCA frequencies
3. Secondary control of aircraft guard frequencies
4. Secondary control of land/launch frequencies
5. Secondary control of air tactical frequencies.

3.4.1.2 CDC.

1. Primary control of all air tactical frequencies
2. Primary control of aircraft guard frequencies
3. Secondary control of ship-shore air traffic control administrative frequencies.

3.4.1.3 PriFly.

1. Primary control of land/launch frequencies
2. Secondary control of aircraft guard frequencies
3. Secondary control of [departure control](#) and final approach frequencies.

3.4.2 Voice Procedures. Strict radio discipline is mandatory. Voice procedures must be concise and should not vary appreciably from standard air traffic control phraseology as set forth in the Carrier Air Traffic Control Handbook NAVAIR

AE-CVATC-OPM-000 FAA Order 7110.65 and ACP 165. Ship's call sign shall be used on initial contact with marshal. Squadron tactical call signs should always be used to prevent confusion.

3.4.3 Recording of Radio Circuits. Radio circuits used for the control of air traffic shall be recorded continuously during hours of operation. CATCC shall ensure PriFly frequencies are recorded during Case I/Case II operations.

3.4.4 Communication Security. COMSEC is best accomplished by strict adherence to established principles of radio discipline. Additionally, secure voice radio equipment in naval aircraft and carriers offers a significant COMSEC capability that should be utilized to the greatest extent practicable. All units with COMSEC capability should develop tactical doctrine designed to deny SIGINT forces access to vital intelligence. Detailed functional descriptions of COMSEC equipments are found in pertinent classified documents.

All personnel who have access to radio equipment must be briefed that certain restrictions exist on all radio transmissions to prevent disclosure of EEFI to the enemy.

3.5 EMERGENCY CONTROL PROCEDURES

From a control standpoint, aircraft emergencies fall in the following three broad categories:

1. Communication failures
2. NAVAID failures
3. Other aircraft system failures.

The nature of some emergencies requires priority and/or diversionary measures. The ultimate resolution of these emergencies involves a command decision based upon the type of emergency and weather conditions in the recovery area. It is imperative that the controlling agency collect every pertinent detail that might aid in the evaluation of an emergency and keep the command and other interested agencies properly informed.

3.5.1 Initial Control Responsibility. The initial control responsibility for aircraft emergencies rests

within visual range of the ship will normally be controlled by the air officer. Outside the visual range of the ship, aircraft in an emergency shall be controlled by either CDC or CATCC. Aircraft in distress should not change radio frequencies if satisfactory radio contact is established.

3.5.2 Basic Procedures. The procedures for pilots to follow when experiencing communications and/or navigation equipment failures are listed in Figure 3-1. Controlling agencies shall be familiar with and alert for conditions indicating communication or navigation failures and perform the following as appropriate:

1. Attempt to establish communications with the aircraft.
2. Vector the aircraft as appropriate.

If unable to communicate with the aircraft in difficulty:

1. Identify on radar and maintain a track.
2. Vector available aircraft to join if practical.
3. Alert air operations watch officer and PriFly.
4. Broadcast instructions and essential information on normal control frequencies and guard.

Emergency procedures during penetration or letdown are covered in Chapter 5. Emergency procedures for aircraft system failures are covered in the appropriate aircraft NATOPS flight manual. Lost communication emergency squawks are listed in Figure 3-2.

3.6 PLANE GUARD HELICOPTER

3.6.1 Control Authority. A helicopter, when designated primary plane guard, shall be under the operational control of the air officer during launches and recoveries. During Case II or III operations or advisory control, the base recovery course and all course changes shall be provided by CATCC using a frequency monitored by primary flight control. CATCC shall conduct a radio check with the plane guard

helicopter at least every 20 minutes during Case III. Concurrent USW/plane guard helicopter operations may be conducted provided a responsive plane guard capability is maintained during launch/recovery.

3.6.2 Plane Guard Station. During carrier qualification landings and/or when concurrent tactical/plane guard operations are not authorized, the pattern depicted in Figure 3-3 should be used. For concurrent operation, during launch/recovery, the designated planeguard helicopter is “on station” when operating within 20 NM (Day) or 10 NM (Night) of the carrier. The helicopter shall remain within UHF range and monitor the assigned air control frequency at all times.

3.6.3 Restrictions. During launch/recovery, no concurrent USW/plane guard operations shall be conducted within the shaded area depicted in Figure 3-4 without the explicit approval of the air officer. The maximum altitudes when conducting concurrent USW/plane guard operations shall be as depicted in Figure 3-4.

3.6.4 Search and Rescue. In the event of a plane guard incident, the designated plane guard helicopter shall immediately respond unless otherwise directed by the air officer.

The air officer normally will be responsible for controlling plane guard efforts when they are within sight of the ship. CDC/CATCC normally will control plane guard efforts when outside visual contact of the air officer. The CDC officer should normally be responsible as the ship’s overall plane guard coordinator. SAR requirements are listed in Figure 3-5.

A switch to a discrete plane guard frequency will be made when directed by the controlling agent/agency.

WARNING

During the recovery of aircraft with forward firing ordnance, the plane guard helicopter shall not be positioned on the starboard side from the 360 to the 090 degree relative bearing within 5NM from the carrier.

TYPE OF FAILURE	FLIGHT CONDITIONS	
Transmitter failure with or without receiver failure (navigation aids serviceable).	VMC	*IMC
	<ol style="list-style-type: none"> 1. Join up if possible. 2. Maintain VMC. <ol style="list-style-type: none"> a. Enter VMC landing pattern. b. Use standard visual signals when in range of ship. c. Watch for light signals from ship. 3. Squawk Mode III 7600, "IDENT," and Mode I in accordance with Figure 3-2. 4. In receiving, follow instructions. 5. Broadcast intentions periodically, whether or not transmitter is known to be serviceable. 6. Tune in parent CV data-link frequency. 	<ol style="list-style-type: none"> 1. Transition to VMC if possible and continue VMC. 2. Proceed to emergency marshal. 3. Squawk Mode III 7600, "IDENT," and Mode 1 in accordance with Figure 3-2. 4. Watch for joinup. 5. Hold at emergency marshal until EEAT. 6. Commence approach at EEAT. Squawk in accordance with Figure 3-2. 7. If receiving, follow instructions. 8. Broadcast intentions periodically whether or not transmitter is known to be serviceable. 9. Tune in parent CV data-link frequency.
Navigation aids and transmitter failures, with or without receiver failure.	<ol style="list-style-type: none"> 1. Perform same procedures as for communications failure, or 2. When position is unknown: <ol style="list-style-type: none"> a. Navigate by DR to best position. b. Squawk in accordance with Figure 3-2 or EMERGENCY as required. c. Fly appropriate triangles. d. Watch for join up. 3. Tune in parent CV data link frequency. 4. If all above fails, bingo to nearest suitable field at appropriate fuel state. 	<ol style="list-style-type: none"> 1. Transition to VMC if possible and maintain VMC. 2. Navigate by DR to best position. 3. Squawk in accordance with Figure 3-2 or EMERGENCY as required. 4. Fly appropriate triangles. 5. Watch for joinup. 6. If receiving, follow instructions. 7. Broadcast intentions periodically whether or not transmitter is known to be serviceable. 8. Tune in parent CV data-link frequency.
<p>* All procedures are for single aircraft. When in company, VMC or IMC, remain in company and use hand signals between aircraft.</p>		

Figure 3-1. Basic Emergency Procedures for Communication/Navigational Equipment Failure

<p>Mode III — Lost communications (transmitter and/or receiver) squawk Code 7600. Emergencies squawk 7700.</p> <p>Mode I — The following codes will amplify difficulties in conjunction with a Code 7600 or 7700. No receiver shall mean that the primary UHF, auxiliary receiver, and UHF/VHF Guard receiver are inoperative. If any receiver is operative, the controller is capable of controlling the aircraft utilizing IFF standby squawks and/or aircraft turns to acknowledge receipt of instructions.</p>		
<p>Note</p> <p>Below 2,500 feet, pilots must be aware of the dangers of changing IFF codes.</p>		
<p>1. HEFOE Squawks</p>		
Mode I		Mode III
First digit	Second digit	
0 — ok	0 — No radio reception PALS/ ILMOK	
	1 — No radio reception, TACAN OK	
1 — Hydraulic		7700/7600 (with HEFOE code, use Code 7700)
2 — Electrical	2 — No radio reception, ADF OK	
3 — Fuel	3 — Radio reception, OK, no NAVAIDs	
4 — Oxygen		
5 — Engine		
<p>2. Assistance Required Squawks</p>		
<p>All 7 — Mode I squawks indicate no receiver and no NAVAID(s).</p>		
Mode I		Mode III
70 — Desire tanker to join		Fuel on board (up to 7,400)
71 — Intend bingo		
72 — Desire aircraft to assist		
<p>3. Limited Communication Squawks</p>		
<p>Require a 1-minute cycling of Mode III from 7600/7700 to desired channel.</p>		
Mode I		Mode III
60 — Aux. Rec. (ADF) channel _____		Channel usable (0100-2000, and 2100 = Guard)
61 — No NAVAID(s) Rec. on channel _____		
62 — TACAN ok. Rec. on channel _____		

Figure 3-2. Lost Communication Emergency Squawks

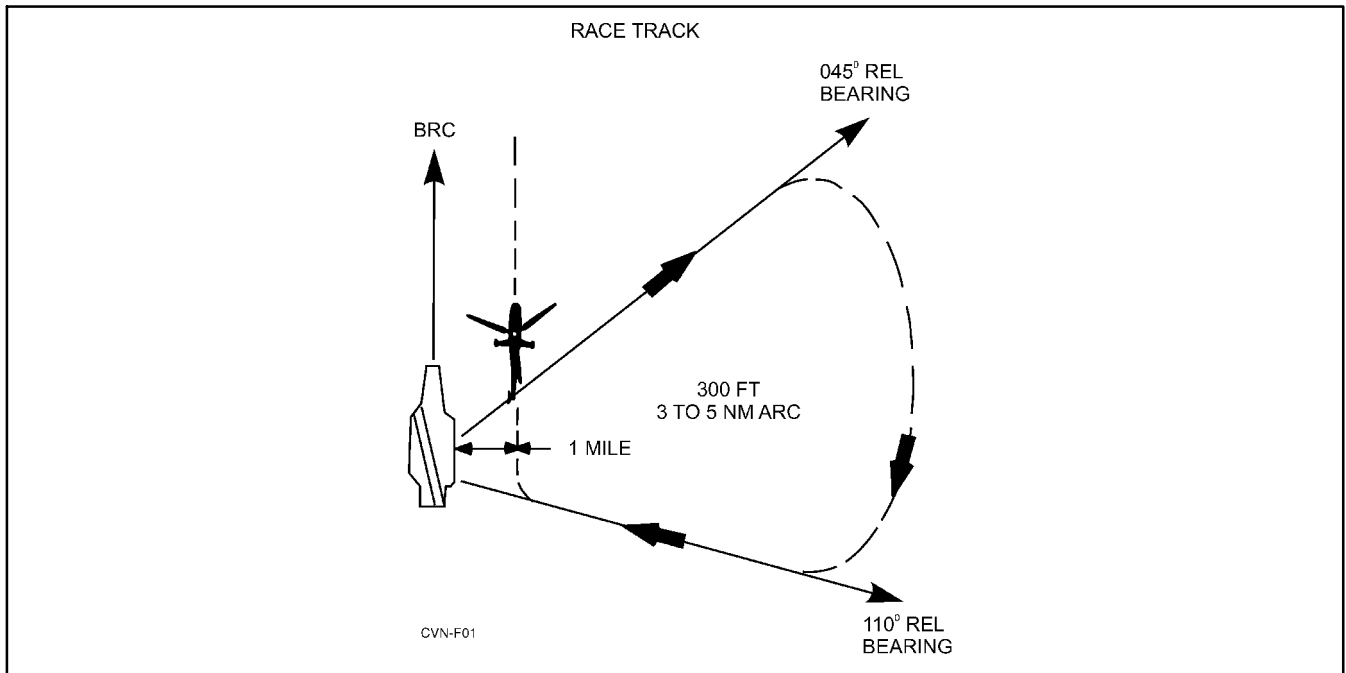

Figure 3-3. Starboard Holding Pattern

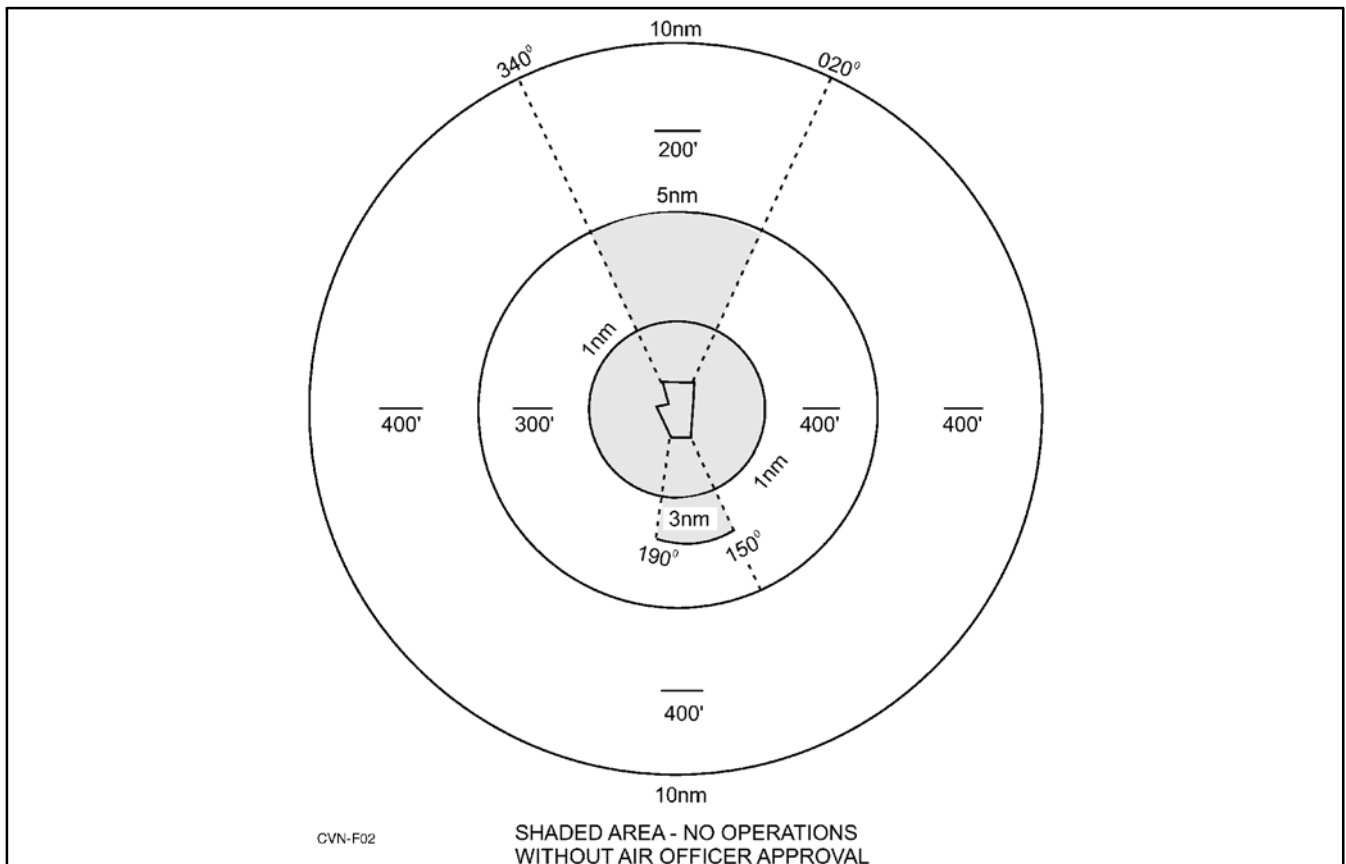

Figure 3-4. Helicopter Restrictions During Launch/Recovery

	WITHIN RANGE OF SAFE LANDING FIELD		OUTSIDE RANGE OF A SAFE LANDING FIELD
	DAY	NIGHT OR LOW VISIBILITY	DAY & NIGHT
CARRIER QUALIFICATIONS	A or B	A, C or D	(1)
FIXED WING CURRENCY	A or B	A, C or D	(1)
CYCLIC OPERATIONS	A or B	A, C or D	(1)
HELO/OPS SHIP ANCHORED/BETWEEN FLIGHT OPS	E	E	E

A. One plane guard helicopter airborne and one helicopter in Condition III (2).
 B. One surface combatant in lifeguard station and one helicopter in Condition III (2).
 C. One plane guard helicopter airborne and one surface combatant in lifeguard station.
 D. One helicopter in Condition III (2) and two surface combatants, one in lifeguard station and one within UHF radio range.
 E. One helicopter in Condition III (2) and one helicopter in Condition IV.

NOTE:

(1) When outside range of a safe landing field, the same rescue unit criteria apply for day and night except that at least one surface combatant shall normally operate within UHF radio range of each aircraft carrier under both day and night conditions.
 (2) The CV Motor Whale Boat and crew may be used in place of a helicopter in Condition III at CV/N CO's discretion.

Figure 3-5. Minimum SAR Requirements

CHAPTER 4

LAUNCHING AIRCRAFT**4.1 PRELAUNCH PROCEDURES**

As early as possible before launch, the catapult officer and deck launching officer shall advise the air officer of the launch wind requirements. The air officer shall relay this information to the bridge.

The aircraft handling officer shall perform the following prior to each launch or setting of Condition I or II, as described in [paragraph 4.11](#).

1. Assign aircraft to each event specified on the air plan.
2. Brief key flight and hangar deck personnel on the following:
 - a. Starting and launching sequence
 - b. Disposition of downed and spare aircraft
 - c. Aircraft to be towed or taxied forward after the launch
 - d. Recovery spot (when a recovery is scheduled to follow the launch).
3. Ensure the air gunner or his designated representative attends the aforementioned brief to comment as appropriate on ordnance safety precautions or weapon handling procedures incident to the launch and forthcoming recovery if applicable.
4. Ensure the launch spot is relayed to the ready rooms and inform PriFly, CATCC, and the ready rooms as early as possible of the side numbers of aircraft assigned for launch.
5. Conduct FOD walkdown (minimum one day/one night and as required).

The flight deck officer or his representative shall tour the flight deck to ensure the following:

1. Propellers, tailpipes, and helicopter rotors have sufficient clearance
2. Each aircraft can be safely taxied from its spot
3. Deck-edge antennas are properly positioned and the jackstaff, flagstaff, bow rails, and stern rails have been removed and stowed
4. No gear is adrift on the flight deck.

The aviation fuel officer or his designated representative shall ensure all aircraft, including standbys, have been fueled as prescribed in the air plan. Discrepancies shall be brought to the attention of the aircraft handling officer immediately.

The air wing weapon officer or his designated representative shall visually inspect each aircraft to ensure ordnance loading is as prescribed in the ordnance load plan. Discrepancies shall be brought to the attention of the aircraft handling officer and ordnance handling officer immediately.

WARNING

Under no circumstances shall the launching officer participate in the removal of protective devices from the catapult track (i.e., slot seals or buttons). The catapult officer's primary function is as a final inspector.

The launching officer(s) shall brief the topside catapult crew(s) and ensure all equipment is ready and that sufficient launching accessories are available to complete the launch. These tasks shall be completed prior to each launch. In addition, he shall verify fuel and ordnance loading by consultation with aviation fuel and ordnance personnel. He shall then compute aircraft launch weights.

The pilot shall confirm fuel, ordnance, and gross weights in writing, which will be submitted to flight deck control prior to man-up time.

4.1.1 Manning Aircraft. Approximately 45 minutes before launch time, flightcrews will be ordered to man aircraft. When called, they shall proceed to their aircraft via the designated route and conduct preflight inspections as expeditiously as safety permits.

4.1.2 COD/VOD Aircraft. COD/VOD aircraft passengers shall be escorted to and from the aircraft by the ATO or his assistant. The ATO or his assistant shall remain with the passengers until they have been embarked. Passengers and cargo will not be off-loaded until the ATO or his assistant is present. Flight deck survival equipment (cranial helmet, goggles, and floatation equipment) shall not be removed until passengers are well clear of the hazards of the flight deck environment.



- For off-loading passengers and cargo, both engines of the COD should be shut down. At a minimum, the engine on the same side of the entrance hatch shall be secured.
- The ramp shall not be opened/closed externally without confirmation from the aircraft commander.
- The Mk 1 life preserver, vest type (float-coat) with auto inflator unit assembly is not authorized for use aboard aircraft.

4.2 LAUNCHING FIXED-WING AIRCRAFT

4.2.1 Engine Start and Turnup. Prior to starting engines, the air officer shall issue appropriate orders or information over the flight deck announcing system to ensure all prestart preparations are completed and all personnel on the flight deck are alerted.

Note

The mechanical latching of weapons on aircraft racks/launchers shall be completed before the engine(s) on that aircraft is started for launch.

The air officer shall ensure all flight deck personnel are indoctrinated in and adhere to the positioning of aircraft and aircraft starting units so that the established minimum distances are maintained. Pilots and aircrews shall be made aware of proper positioning criteria. The responsibility for safe starting of all aircraft rests with the air officer. All personnel shall follow the prescribed procedures when operating aircraft and aircraft starting units. All unsafe starting conditions shall immediately be called to the attention of cognizant personnel.



Hot exhaust from aircraft and aircraft starting units is a serious hazard when operating in close proximity to aircraft, aircraft components, fuel, weapons, equipment, external store CADs, and personnel.

Engines shall be started only on signal and under the positive control of PriFly. During the starting evolution, the aircraft handling crew shall remove the towbar if necessary for accomplishment of preflight checks and the plane captain shall assist the pilot as necessary with preflight checks. Towbars shall remain on or in the immediate vicinity of aircraft parked in the landing area or in a position that fouls the deck until that aircraft is ready for taxi.



Prior to start, ensure nosewheels are not cocked.

The plane directors shall monitor the aircraft throughout the warmup and checkout period. Control is assumed by the plane captain for preflight checks only.

Turboprop aircraft shall not be turned up above 1,500 shaft horsepower (SHP) without specific clearance from a flight deck director. The pilot shall request clearance to turn up by giving his director the one finger turnup signal. The director, after checking chocks and tiedowns and ensure the area behind the aircraft is clear, shall return the signal, thereby clearing the pilot for turnup.

WARNING

Clearance for turnup shall not be given by anyone other than a flight deck director.

While an engine is turning up at high power, the director shall continuously check the area behind the aircraft. The pilot shall frequently look at the director to ensure the "all clear" signal is still being given. After completing all poststart checks, the pilot shall signal the director, indicating the status of the aircraft. The director will relay the signal to the officer or petty officer in charge of that area of the flight deck.

4.2.2 Final Preparations for Launch.

Approximately 15 minutes before launch, the air officer will initiate the following prelaunch checklist:

1. Wind - Verify the estimated wind available for launch and notify bridge of maximum/minimum wind requirements.
2. List - Check ship's list to ensure a level deck.
3. Jet blast deflector cooling- Ensure saltwater cooling is functioning on all active JBDs.

If aircraft are to be deck launched, the launching officer shall compute the required deck run and confirm it with the air officer. The catapult launching officer shall inspect the catapult track(s) and adjacent flight deck area to ensure they are clear of chocks, towbars, or other equipment. By this time, the following personnel should have manned their launch stations:

1. LSO
2. Arresting gear personnel
3. ILARTS operator
4. Lens operator
5. [PALS](#) radar operator
6. Mobile firefighting equipment operators.

4.2.3 Taxiing. Before ordering removal of chocks, directors shall signal for the pilot to hold brakes. It is imperative that the pilot acknowledge this signal by affirmative nod of the head in the daytime and by a

flashlight at night. The flight deck officer will control the rate at which aircraft are moved toward the catapult(s) or deck launch spot, ensuring a constant steady flow of traffic while avoiding unnecessary crowding. All taxi signals shall be answered promptly and accurately unless the pilot considers there is a dangerous situation existing or developing, in which case he shall stop.

WARNING

- A director shall not leave an aircraft unattended after chocks and tiedowns have been removed.
- All movement of aircraft shall be under the control of a plane director. Safety men shall be posted as required to assist the director.
- Aircraft shall not be taxied until pretaxi checks are required procedures prescribed in the appropriate NAVAIR weapon/store loading checklists/store reliability cards have been completed.
- COD aircraft shall not be unchained until all passengers and aircrew are strapped into their seats and the aircraft commander has passed the up and ready signal.

If a pilot loses sight of his director, he shall stop immediately. The director shall stay in view of the pilot at all times and remain stationary while controlling aircraft. If it is necessary to change his position while controlling an aircraft at night, the director shall signal the pilot to hold brakes. He will continue giving the hold brake signal while moving expeditiously to the new position, then resume movement of the aircraft.

Control of a taxiing aircraft shall not be passed from one director to another until the receiving director signals by extending one arm vertically that he is ready to accept control. A director shall not give signals to a pilot who is already under the control of another director except in an attempt to avert an accident.

When a nosewheel tiller/towbar is to be used in taxiing an aircraft, the director shall signal the pilot that a tiller/towbar is being attached and shall discontinue

giving him directional signals. The pilot must then be careful to avoid differential braking and/or nosewheel steering and use the brakes only for slowing or stopping the aircraft. Nosewheel steering shall not be engaged with tiller/towbar attached.



Care should be exercised when aircraft are taxied, spotted, or towed close behind a JBD when another aircraft is at high power on the catapult.

4.2.4 Catapult Launching. Prior to the launch, the launching officer shall relay the minimum and maximum WOD requirements for the forthcoming launch to the air officer who shall, in turn, advise the bridge.

During CARQUAL operations, the pilot shall transmit aircraft side number, fuel weight, and gross weight during a two-way radio check. This report is required prior to initial launch, after hot refueling or when pilot switch occurs. The air officer shall ensure aircraft side number and gross weight is passed to confirmed by the launching officer.



- During CARQUAL operations, a close monitoring of aircraft gross weight is mandatory by the air officer, launching officer, pilots, and squadron representatives.
- Turboprop aircraft shall not be launched from waist catapults when jet/turboprop aircraft with engines operating on No. 2 catapult or a possibility exists that hot exhaust gases from aircraft spotted anywhere on the flight deck may be ingested into the turboprop engine during launch.



Squadron aircraft inspectors shall not perform inspections while an aircraft is taxiing. It is mandatory to remain well clear of rolling tires at all times to prevent injury.



Aircraft with wing-or pylon-mounted engines shall not be launched from catapults having only a single panel JBD if aircraft within 200 feet aft of the JBD are not properly tied down.

In positioning an aircraft on the catapult, the director must be acutely aware of the activities of the catapult crewmen and control the aircraft's speed and movement in such a way that personnel safety will not be jeopardized. Pilots must guard against the tendency to use excessive power that invariably results in roughness and poor control and jeopardizes launching accessories.

As the aircraft approaches the catapult, the director shall ensure the aircraft is in the takeoff configuration. JBDs shall be raised as appropriate.



All JBD operators/safety observers shall ensure aircraft clearance is sufficient prior to raising or lowering JBD. Catapult three requires a JBD safety observer at all times. Bow catapults utilizing JBD deckedge control boxes require one JBD safety observer per catapult. JBD safety observers shall be positioned on the furthest side of the JBD away from the operator. The safety observer will signal the JBD operator with hand/ wands when the aircraft is clear and the JBD can be raised.

For aircraft using the nosegear launch system, the director shall stop the aircraft at the entry wye area of the

guide track. The holdback man shall attach the holdback bar. The director shall signal the pilot and the hookup petty officer to lower the launch bar.



Aircraft launch bar should not be lowered outside of the entry wye. Excessive wear, burring, and hangup may occur if the bar passes over the deck cleat link track onto the entry wye.

Before taxiing past the shuttle, the pilot shall verify the aircraft gross weight by giving a "thumbs up" signal during the day or a circular motion with a flashlight at night. A "thumbs down" or negative signal will not be used to indicate disagreement with the gross weight board. If the pilot does not agree with the gross weight, he will request adjustment as follows.

1. During the day:
 - a. To raise the gross weight, hold hand flat with palm up and move in a vertical direction, emphasizing the upward motion.
 - b. To lower the gross weight, hold hand with palm down and move in a horizontal direction.
2. At night:
 - a. To raise the gross weight, move flashlight in a vertical direction, emphasizing the upward motion.
 - b. To lower the gross weight, move flashlight in a horizontal direction.

Note

Weight board will be changed in 500- or 1,000-pound increments in accordance with applicable aircraft launch bulletins.

When more than two correction steps are required on the weight board or any difficulty is experienced in confirming the gross weight, the aircraft shall not be launched until positive determination can be made by the air officer and confirmed by the pilot and launching officer.

When an aircraft carrying ordnance requires arming, the aircraft will be taxied into the arming area. Nose-tow aircraft shall be stopped after the appropriate JBD has been raised and prior to positioning nose-tow launch bar over shuttle spreader; bridle type aircraft will be positioned tight in the holdback without the bridle attached. Prior to arming, aircraft shall be properly configured for flight. The director shall ensure all personnel are clear and then direct the aircrew's attention to the ordnance arming supervisor for arming. When the arming has been completed and the arming crew is clear, the ordnance arming supervisor will signal the pilot with a "thumbs up" signal (day) or display a vertical sweep with a red, banded wand (night) and then direct the pilot's attention back to the director.

As the aircraft is positioned on the catapult, the squadrons' aircraft inspector shall inspect the aircraft to ensure it is properly configured and ready for flight. He shall give a "thumbs up" signal (day) or display a blue wand held vertically (night) to indicate that he considers the aircraft ready for launch. He shall continuously display this signal at a position from which he is clearly visible to the launching officer. Should the aircraft inspector desire to prevent the aircraft from being launched, he shall immediately give a "suspend" signal (day) or display a blue wand moved horizontally (night) to the director or launching officer who has control of the aircraft at the time the discrepancy is discovered.



WARNING

Aircraft shall not have bridle/pendant attached or the nose-tow launch bar over shuttle spreader until the aircraft is armed and properly configured for flight.

As the ship approaches the launching parameters, the air officer shall monitor the wind repeater and keep the launching officer(s) advised of the relative wind velocity. Upon receiving permission from the bridge to launch aircraft, he shall make a final check to ensure relative wind is within the envelope prescribed in the applicable aircraft launching bulletin. This shall be accomplished before changing the rotating beacon(s) from red to green (this lights the PriFly "go" light on the catapult officer ICCS console when in use), thereby clearing the launching officer(s) to begin launching.

4.3 ICCS CATAPULT LAUNCH PROCEDURES

When the launching officer observes the aircraft type, aircraft weight, and side number, he shall set the CSV command dials on the COC to the setting prescribed in the applicable aircraft launching bulletin. He then relays this information to the CCP operator, including the appropriate wind value. After the CCP operator verifies the CSV setting is correct, utilizing the proper aircraft launching bulletin, depress the CSV setting pushbutton on the CCP. The CCP operator shall verify the position of the CSV by comparing the digital readout on the CCP with the mechanical counter on the CSV. If a mismatch occurs with the command setting and any remote readout, the launching officer shall suspend the catapult and place it in a "down" status until the malfunction has been corrected.



If these verification procedures are not strictly followed, it greatly increases the chances of launching an aircraft at an improper CSV setting that may cause loss of the aircraft and/or the crew.

Note

An independent verification of the CSV selector by the launching officer shall be made by the CCP (Central charging panel operator). The vital nature of this requirement necessitates extensive training of the CCP operator in computation methods and proper use of aircraft launching bulletins.

If at any time it is necessary to change the CSV setting after the launch bar is in the shuttle, the catapult shall be suspended and suspend procedures shall be carried out to completion.

If the CSV is inoperative in the automatic mode, the launching officer may select the jog or handwheel position on the CSV mode selector switch and continue operations.



Operation of the catapult in the defeat interlock mode shall only be accomplished with permission of the commanding officer. If either mode is used, instructions delineated in the Catapult NAVAIR 51-15 series Operational Organizational/Intermediate Maintenance Manual.

If the MCC operator observes a red malfunction light, a red status light, or the catapult area fouled, he shall press the suspend pushbutton and notify the launching officer.

The CCP operator shall continually check his panels and ensure all lights and readouts indicate a "go" condition. If a "no-go" condition exists, he shall press the catapult suspend pushbutton and notify the MCC operator.

When all conditions are satisfactory for launch, the green catapult ready light at the COC and the white lights at the CCP and MCC will be on. If the catapult ready lights are not on, the cause must be investigated and corrected.



If the catapult ready condition is lost even momentarily, the launching officer, the MCC operator, or the CCP operator shall suspend the catapult and determine the cause. When the malfunction or other condition causing the loss of catapult ready has been corrected, the operator of the suspending station shall remove the suspend by pressing the suspend pushbutton. At no time shall the launching officer place the catapult in tension without first ensuring a catapult ready condition exists.

Prior to signaling the catapult safety observer to initiate catapult hookup, the launching officer shall perform the following:

1. Ensure the capacity selector valve is set in accordance with the appropriate aircraft launching bulletin.

2. Make a final check to ensure the area forward of the catapult is clear.
3. Ensure wind velocity and direction are within limits and in accordance with the applicable launch bulletins.
4. Ensure the green rotating beacon controlled by primary flight control is on.
5. Ensure the catapult is in a "catapult ready" condition.
6. Ensure the aircraft is properly configured for flight.
7. Ensure the "catapults interlocked" light is illuminated unless intentionally operating in the catapult "not interlocked" mode.
8. Ensure the appropriate go/no-go chart applicable to multicatapult operations has been reviewed.

When all conditions are satisfactory, the launching officer shall signal the safety observer to hook up the aircraft.

After receiving the hookup signal from the launching officer and prior to signaling the topside safety petty officer to initiate hookup, the catapult safety observer shall perform the following:

1. Ensure the area forward of the catapult and the catapult "safe shot line" are clear.
2. Ensure the JBD is raised and that aircraft immediately aft of the JBD are configured to sustain turbulence from the launching aircraft.
3. Ensure the aircraft is properly configured for flight.
4. Ensure the aircraft has been properly armed if required.
5. Ensure the green rotating beacon controlled by primary flight control is on.
6. Ensure the catapult topside petty officer is giving a "thumbs up" signal indicating he is ready for hookup.

When all conditions are satisfactory, the topside safety observer shall give the hookup signal to the topside safety petty officer.

When the catapult topside safety petty officer receives the hookup signal from the safety observer, prior to signaling aircraft tension, he shall perform the following:

1. Ensure the catapult holdback is attached and that all slack is removed from the bridle cable and holdback unit. In the case of nosegear launch aircraft, ensure the holdback is properly seated in the buffer hooks and that the aircraft has fully engaged the nosegear launch unit.
2. Ensure the bridle hookup men have correctly positioned the bridle/pendant to ensure proper engagement between the shuttle spreader and the aircraft tow fittings after tension has been applied.

WARNING

Improper attachment of a bridle or pendant can cause premature separation or failure of these components and result in a mishap.

3. Ensure the JBDs are raised and that personnel are properly positioned.
4. Check the catapult area forward.
5. Ensure all squadron final checkers are clear from underneath the aircraft.
6. Ensure the catapult deck-edge suspend light is not flashing.

The catapult topside safety petty officer shall then give the aircraft "tension signal" to the aircraft director.

After receiving the "tension aircraft" signal from the catapult topside safety petty officer, the aircraft director shall perform the following:

1. Make a final check forward to ensure all personnel and aircraft are clear of the catapult safe shot line.
2. Ensures appropriate JBD's are raised, that personnel are properly positioned, and aircraft directly behind the JBD are positioned and

properly configured for military-rated power of the launching aircraft.

3. Signal the pilot to release the brakes and signal the launching officer in the ICCS to take tension. After the aircraft is tensioned, signal the pilot, if applicable, to raise the launch bar.
4. Turn the aircraft over to the ICCS deck signal lights via catapult safety observer.

After receiving the "tension aircraft" signal from the aircraft director, the launching officer shall depress the tension pushbutton on the COC (paying particular attention to proper engagement of the shuttle and launch bar or the shuttle and bridle as the catapult shuttle strokes forward). After tension is taken, the topside safety petty officer will perform the following:

WARNING

It is mandatory that it is positively determined that the aircraft launch bar is properly seated in the NGL shuttle spreader after tension is taken. Mispositioning of the aircraft launch bar can result in the launch bar separating from the shuttle spreader during the launch. F-14 and F-18 aircraft shall not be launched with improper or missing launch bar paint schemes.

1. Inspect for proper hookup and alignment. The pilot, in turn, will release brakes and apply appropriate power in accordance with aircraft NATOPS flight manual.
2. For bridle/pendant aircraft, inspect the bridle hookup to ensure proper engagement with the catapult shuttle/aircraft tow fittings after full power application and tensioning are completed.
3. For nose-tow launched aircraft, inspect the launch bar to ensure proper engagement with the catapult shuttle after full power application and tensioning are completed.
4. When all conditions are satisfactory, signal "thumbs up" to the catapult safety observer while exiting from under the aircraft.

WARNING

Catapult sound-powered phone circuits shall be restricted to essential only communications after the aircraft has been placed in tension.

Upon observing the catapult topside safety petty officer exiting from underneath the aircraft giving a "thumbs up" signal (day)/white wand signal (night), the launching officer shall depress the military power pushbutton and (if applicable) combat power pushbutton (green for military, amber for combat power).

The pilot shall apply full takeoff power and afterburner (if applicable) when the respective deck signal lights are illuminated.

Upon completing his final inspection of the aircraft, the squadron aircraft checker shall signal a "thumbs up" (day)/wand up (night) to the catapult safety observer and hold the signal until the aircraft is launched.

When the pilot is ready to launch, he shall so signify by saluting the catapult safety observer or at night turning the navigation lights on steady. The pilot shall ensure no exterior lights are on before the military power/combat power lights are illuminated.

WARNING

Once the aircraft is tensioned on the catapult and turned up to takeoff power, the pilot shall not adjust his visor or make any other movement that might be mistaken for a salute.

If for any reason the pilot wishes to abort the launch, he shall so indicate by transmitting "suspend-suspend catapult no. ____" and by shaking his head negatively. The safety observer shall then initiate the suspend procedure. At night the pilot shall transmit "suspend-suspend catapult no. ____" and shall not turn on external/navigation lights. External/navigation lights shall be turned off if already on.

WARNING

- High power maintenance turns shall not be conducted on the catapult. Longer than normal military power turns on the catapult may be conducted for check flights. At no time during such evolutions shall the pilot reduce power without directions from the catapult officer.
- If there is any doubt in the mind of the topside safety petty officer, director, squadron aircraft checker, or any other individual on the flight deck as to satisfactory hookup, aircraft configuration, or proper catapult condition, they shall so indicate to the catapult safety observer by initiating a crossed arm "suspend" signal (day) or horizontal wand movement (night). Below decks personnel shall depress the suspend pushbutton and/or state "suspend" over the sound-powered phone circuit.

The catapult safety observer after observing the pilot's ready to launch signal returns the pilot's salute and shall perform the following:

1. Immediately assume a crouched position.
2. Ensure the aircraft is properly configured for flight, paying particular attention to flap/slat setting, open panels, safety pins, wing locks, and stabilator position.
3. Check for a "thumbs up" signal from the catapult topside safety petty officer and the squadron aircraft checker.
4. Check for a clear deck forward.
5. Ensure the catapult deck edge suspend light is not flashing.
6. Ensure all personnel in the immediate area of the catapult are in a crouched position.

7. Ensure the catapult bow safety man is giving a "thumbs up" or green status light.
8. Ensure the aircraft being launched does not conflict with aircraft being launched from other catapults or possible bolters.

The catapult topside safety observer shall then give a "thumbs up" signal (day) or a vertical green wand (night) to the launching officer.

Upon observing the pilot's salute/aircraft lights illumination and the catapult topside safety observer in a crouched position, the launching officer shall depress the final ready pushbutton and begin his final scan.

After observing the catapult final ready light illuminate, the CCP operator will conduct a final scan of the central charging panel (paying particular attention to ensure the launch valve clock timers have reset to zero). If there is an indication of any malfunction, he shall immediately suspend the catapult.

After observing the catapult final ready light illuminate, the MCC operator shall conduct a final scan of the **monitor control** console (checking for any malfunction lights or red status lights) and shall announce to the launching officer the steam pressure and "clear forward." If there is any indication of a malfunction, he shall immediately suspend the catapult.

If all conditions are "go," the launching officer will complete his final scan which shall include the following:

1. Clear area forward of the catapult and observe the bow/waist safety man giving a "thumbs up" or a green light.
2. Monitor console indications for errors.
3. Observe a green PriFly go light on the catapult officer's console.
4. Observe a green steam pressure "go" light on the COC.
5. Observe wind conditions within parameters.
6. Observe matching CSV command readouts and position readouts.

7. Observe catapult safety observer, topside safety petty officer, and squadron checker giving a "thumbs up" signal.
8. Observe aircraft properly configured for flight.
9. Observe pilot in proper position for catapult launch.
10. Check deck pitch.

After ensuring all conditions are satisfactorily met, the launching officer shall depress the fire pushbutton.

4.3.1 ICCS Emergency Procedures

4.3.1.1 Catapult Suspend. Any time prior to the fire pushbutton being depressed, the catapult launch may be stopped and the launch aborted by initiating a catapult suspend. Upon observing a suspend condition or being notified of a catapult suspend situation, the catapult officer shall initiate the suspend procedure by immediately depressing the catapult suspend pushbutton on the COC. Any flight deck crewman who detects any cause for aborting the launch may suspend the catapult launch by immediately giving the suspend signal.

Anytime a suspend is initiated, it must be carried out to completion. This includes untensioning of aircraft, reduction of aircraft power to idle, and moving the shuttle forward of the launch bar for all aircraft.

Upon observing the catapult suspend signal or the flashing red deck edge suspend light, the catapult topside safety observer shall immediately give the suspend signal followed by the untension aircraft signal.

Upon observing the untension aircraft signal, the catapult officer shall depress the maneuver aft pushbutton on the COC.

WARNING

The pilot shall keep the aircraft at full power until specifically directed to throttle back by the catapult topside safety observer.

If the catapult water brake operator initiated the suspend, the catapult officer shall direct the water brake operator to remove his suspend prior to depressing the maneuver aft pushbutton. In case of electrical failure, the catapult officer shall direct the central charging panel operator to depress the manual override on the maneuvering valve.

For NGL aircraft, the catapult topside safety observer shall upon observing the shuttle move aft give the raise launch bar signal to all aircraft capable of raising launch bars. When the aircraft launch bar is clear of the catapult shuttle, the topside safety observer shall give the "shuttle forward" signal to the catapult officer.

Upon observing the shuttle forward signal, the catapult officer shall depress the bridle tension pushbutton on the COC. After the catapult shuttle has moved to a position in front of the aircraft launch bar, the topside safety observer shall after standing in front of the wing and in plain view of the pilot give the "throttle back" signal to the pilot.

For those aircraft not capable of raising launch bars, the catapult topside safety observer shall give the "throttle back" signal to the pilot after observing the shuttle move aft. After the aircraft is throttled back, the catapult topside safety observer shall direct the hookup petty officer to manually raise the launch bar prior to giving the "shuttle forward" signal to the catapult officer.

For bridle-type aircraft, the topside safety observer shall give the "throttle-back" signal to the pilot after observing the bridle/pendant fall free of the aircraft.

Following catapult secure, the cause of the suspension must be determined and corrected before putting the catapult back into operation.

4.3.1.2 Catapult Hangfire. If the catapult does not fire within 10 seconds after the pushbutton has been depressed, a hangfire condition exists. After 10 seconds, the catapult officer shall press the catapult suspend pushbutton and then call, "Rotate the emergency cutout valve," to the control charging panel operator via the sound powered phone circuit. The catapult officer will then communicate the hangfire condition to the catapult safety observer via voice communication system and give the hangfire signal. The safety observer, upon receiving word from the CAT officer that a hangfire exists, shall give the hangfire signal until the catapult is declared safe. When the

catapult is safe, normal suspend procedures are followed for the type of aircraft involved.

The central charging panel operator shall then remove the cotter pin, unscrew the stop screw, and rotate the emergency cutout valve to the emergency position. He shall then press the maneuver aft pushbutton on the CCP and hold it for 15 seconds to release tension. If the hangfire was caused by an electrical failure, the CCP operator shall press the manual override pushbutton on the maneuvering valve of the retraction engine for 15 seconds. When this is completed, he shall notify the catapult officer.

Upon observing the catapult deck suspend light flashing and catapult shuttle movement aft, the catapult topside safety observer shall then follow normal suspend procedures for the particular type of aircraft.

The catapult officer shall set in the CSV no-load setting once the shuttle has been maneuvered ahead of the aircraft launch bar. This is to minimize damage should the hangfire result in an inadvertent firing of the catapult.



The central charging panel operator shall not rotate the emergency cutout valve from the emergency position until specifically directed to do so by the catapult maintenance officer.

After the hangfire, the catapult will be placed in a "down" status until the specific cause of the hangfire has been identified and corrective action taken.

After any hangfire and when the causing discrepancy has been discovered and corrected, two successful no loads must be fired before the catapult can again be considered operational.

4.3.2 ICCS Catapult Safety Precautions

1. During catapult operations, no personnel other than those assigned specific duties involving the launching of aircraft shall be permitted in the catapult area or in the catapult machinery spaces.

2. The catapult shall only be fired by/or on signal from the launching officer.
3. The commanding officer shall make the decision to launch aircraft if any of the following situations exists:
 - a. When aircraft will be launched with excess less than 10 knots. The pilot shall also be notified of the intended excess.
 - b. When JBD cannot be raised.
 - c. When the catapult CSV is operating in the defeat interlock mode.
 - d. When the catapult will be fired from below decks emergency panel.
 - e. When catapult stations are manned by personnel not PQS qualified on those stations.
4. Any person who sees a situation that warrants a suspend shall immediately signal "suspend" to the launching officer/catapult safety observer. Any person who observes a "suspend" signal shall immediately repeat the signal.
5. Any person who observes any unusual condition during the launch, such as objects falling from or striking the aircraft, shall immediately inform the catapult officer.
6. The air officer shall inform the aircrew and air operations of any unusual incidents (blown tire, aircraft damage, etc.) that could influence future decisions made by the aircrew of the aircraft involved.



Personnel shall not work or transit immediately behind JBDs with aircraft at launch power on that catapult.

7. If the launch is suspended after forward firing weapons have been armed, ensure those weapons are dearmed when a pushback of the aircraft is required or when the area ahead of the aircraft cannot remain clear until the launch.

8. Clearing turns shall be made only during day VFR launches and shall be made to the "right" off the bow, and to the "left" off the waist catapults. Clearing turns will be governed by ship's policy. Clearing turns are not normally required during CARQUAL evolutions when only one set of catapults is in use.
9. If during launch operations, the aircraft tailhook strikes the catapult or other equipment on the deck or ship's structure, no effort shall be made to effect a normal carrier arrestment.

4.4 MODE I LAUNCHING PROCEDURES

Refer to non-ICCS catapult launching procedures.

4.5 NON-ICCS CATAPULT LAUNCH PROCEDURES

WARNING

F-14 aircraft launches with cutback spreader sideplates shall always be accomplished with filler blocks installed. Failure to use a filler block for F-14 launches can result in launch bar mispositioning on the spreader "nose" vice the required spreader throat. F-14 aircraft launches with filler block can be accomplished with (long) spreader sideplates.

Before the tension signal is given, the topside safety petty officer shall:

1. Ensure appropriate JBDs are raised, that personnel are properly positioned, and aircraft directly behind the JBD area are positioned and properly configured for military-rated power of the launching aircraft.
2. Supervise the attachment of the bridle/pendant and holdback to aircraft.
3. Ensure all unnecessary personnel are clear of the aircraft.
4. Check the catapult area forward.
5. Give the tension signal to the director.

The aircraft director shall:

1. Check the catapult area forward and aft.
2. Ensure appropriate JBDs are raised, that personnel are properly positioned, and aircraft directly behind the JBD are positioned and properly configured for military-rated power of the launching aircraft.
3. Signal the pilot to release brakes and signal the deck-edge operator to take tension. The pilot, in turn, will apply power as specified in the type aircraft NATOPS flight manual.
4. After the aircraft is tensioned on the catapult, signal the pilot, if applicable, to raise the aircraft launch bar.
5. Turn the aircraft over to the launching officer.

After tension is taken, the topside safety petty officer shall perform the following:

1. For bridle/pendant launched aircraft, give "tension bridle arrester lanyard" signal to the bridle arrester operator.
2. Inspect for proper hookup and alignment.
3. Ensure all personnel are clear of the aircraft on the catapult.
4. For bridle/pendant launched aircraft, inspect the bridle hookup to ensure proper hookup after full power application and ensure bridle arrester has relaxed.
5. For nose-tow launched aircraft, inspect the launch bar to ensure proper engagement with the catapult shuttle after catapult tensioning is completed.
6. Signal "thumbs up" to the launching officer with a hand or wand signal if all conditions are satisfactory for launch.

Upon completion of his final inspection of the aircraft, the squadron aircraft checker shall signal "thumbs up" with a hand or wand to the launching officer. The signal must be held until the aircraft is launched.

WARNING

If there is any doubt in the mind of the topside safety petty officer, director, or squadron aircraft checker as to satisfactory hookup or aircraft configuration, they shall so indicate to the launching officer by initiating a crossed arm "suspend" signal (day) or a horizontal wand movement (night).

Prior to giving the pilot the signal for final turnup, the launching officer shall:

1. Visually check for proper aircraft hookup and alignment.
2. Ensure the appropriate JBDs are raised and that all personnel are clear of the aircraft, jet exhaust, or propeller wash.

WARNING

If the JBDs cannot be raised, permission must be obtained from the commanding officer via the air officer before the final turnup signal may be given.

3. Scan the aircraft for proper configuration, stabilator positioning, trim settings, flaps, leaks, and loose panels, doors, or hatches and listen to verify that the aircraft sounds normal at military power.
4. Check for a "thumbs up" signal from the catapult topside safety petty officer and the squadron's aircraft checker.

The launching officer shall signal for final turnup by using the appropriate signals. When the pilot is ready for launch, he shall so signify by saluting the launching officer or, at night, by turning the navigation lights on steady. The pilot shall ensure no exterior lights are on before military power/combustion power (afterburner launch) is selected.

WARNING

Once the aircraft is tensioned on the catapult and turned up to takeoff power, the pilot shall not adjust his visor nor make any other movement that might be mistaken for a salute.

After observing the pilot's ready to launch signal and before signaling the deck edge operator to fire the catapult, the launching officer shall perform the following:

1. Check steam pressure/CSV setting and wind.
2. Check for a green rotating beacon.
3. Make a final scan of the aircraft, aircraft hookup, and squadron aircraft checker for a "ready" signal.
4. Estimate the traffic position of the impending launch and adjust launch signal to prevent unnecessary formation flights.
5. Check aircraft in the groove for position so that if a bolter occurs it will not be in close proximity to the launching aircraft.
6. Check for a clear deck and traffic forward and aft.
7. Check deck pitch.

After ensuring all conditions are satisfactory, the launching officer shall give the signal to launch. Prior to depressing the fire button, the deck-edge operator will make a final look forward and aft to ensure the catapult is clear.

If after coming to full power on the catapult, the pilot desires to stop the launch, he shall do so by shaking his head negatively rather than by giving the "thumbs down" signal. At the same time, he shall transmit, "Suspend, suspend catapult no. ___ ." At night, the visual signal also consists of not turning on the navigation lights.

If for any reason a launch is suspended, the launching officer shall give the "suspend" signal.

WARNING

After an aircraft has been turned up for launching, the signal to throttle back will be given to the pilot by the launching officer. This signal shall not be given until it has been positively determined that the launching bridle/pendant is no longer attached to the aircraft or the launch bar is clear of the catapult shuttle except in an emergency condition. An emergency condition exists if the bridle/pendant cannot be removed or the launch bar cannot be raised without sending personnel under the turned up aircraft. When this occurs, the launching officer shall positively determine that the catapult is in a safe condition before giving the "throttle back" signal. In all cases, the pilot shall not throttle back until the launching officer steps in front of the aircraft and initiates the "throttle back" signal.

1. Safety precautions

- a. During catapult operations, no personnel other than those assigned specific duties involving the catapulting of aircraft shall be permitted in the catapult area or in the catapult machinery spaces.
- b. The catapult shall only be fired by/or on signal from the launching officer.
- c. The commanding officer shall make the decision to launch aircraft if any of the following situations exist.
 - (1) The aircraft will be launched with excess less than 10 knots. The pilot shall be notified of the intended excess.
 - (2) The JBD cannot be raised.
 - (3) Catapult with CSV operated in defeat interlock mode.
 - (4) The catapult will be fired from the below decks emergency panel.

(5) Catapult stations are manned by personnel not PQS qualified at that station.

- d. Any person who sees a situation that warrants a suspend shall immediately signal "suspend" to the launching officer/catapult safety observer. Any person who observes a "suspend" signal shall immediately repeat the signal.
- e. Any person who observes any unusual condition during the launch, such as objects falling from or striking the aircraft, shall immediately make the facts known to responsible personnel.
- f. The air officer shall inform the aircrew and air operations of any unusual incidents (blown tire, aircraft damage, etc.) that could influence future decisions made by the aircrew of the aircraft involved.

WARNING

Personnel shall not work or transit immediately behind JBDs with aircraft at launch power on that catapult.

g. If the launch is suspended after forward firing weapons have been armed, ensure weapons are dearmed if pushback of the aircraft is required or if the area ahead of the aircraft cannot be maintained clear until launch.

- 2. Clearing turns- Clearing turns shall be made only during day VFR launches. Clearing turns will be made to the right off the bow and to the left off the waist catapults. Clearing turns will be governed by ship's policy. Clearing turns are not normally required during CARQUAL evolutions, when only one set of catapults is in use.
- 3. If during launch operations, the aircraft tailhook strikes the catapult or other equipment on the deck or ship's structure, no effort shall be made to effect a normal carrier arrestment.

4.5.1 Deck Launching. If a deck launch is preceded by a catapult launch, it is the responsibility of the catapult launching officer to ensure all personnel and

equipment are clear and that no loose gear is adrift in the deck area to be used (axial/angle). He shall then give the deck launching officer the "clear deck" signal. The air officer shall announce over the 5 MC "stand clear of the angle/bow while deck launching aircraft." The air officer shall not turn the rotating beacon from red to green until this warning is given. When a deck launch is not preceded by a catapult launch, it is the responsibility of the deck launching officer to ensure all the aforementioned is accomplished prior to launch. Arresting gear engines should be set to proper weight setting with retractable sheaves up.

Before clearing the launching officer to commence launching aircraft, the air officer shall verify the previously determined deck run required. The director, in positioning the aircraft for launch, shall ensure its nosewheel is aligned, wings are spread and locked, and flaps are set as required before passing control to the launching officer. The aircraft shall be aligned as accurately as possible with the launch lineup line (landing area centerline when launching down the angle deck). The director will then taxi the aircraft into position, and the squadron's aircraft inspector shall check the aircraft for loose or missing panels or doors, leaks, or other visible discrepancies. If he is satisfied the aircraft is ready for launch, he shall so signify by giving the launching officer the "thumbs up" signal.

The launching officer shall ensure the area behind the aircraft is clear of personnel, equipment, and loose gear. He shall check for a green rotating beacon and a clear deck forward before signaling for the pilot to add power for takeoff.

When signaled to do so, the pilot shall smoothly but expeditiously add power and complete final cockpit checks. In dual-piloted turboprop aircraft, readiness to launch will be signaled by a salute from the pilot, relayed by the copilot if the launching officer is on the starboard side of the aircraft. As power is being applied for launch, the launching officer will check aircraft configuration and inspect it for leaks or other visible discrepancies. After receiving a "thumbs up" from the aircraft inspector and a nod from the pilot, the launching officer will again check for a clear deck forward. He shall ensure the deck and catwalks are clear of personnel before giving the pilot the signal to launch. After receiving the launch signal, the pilot will release his

brakes and execute a takeoff in accordance with the applicable aircraft NATOPS flight manual.

4.5.2 F-14 B/D FCF Reduced Arrestment Thrust System

1. With the shuttle assembly in the waterbrakes, install filler block, lower aircraft launch bar in wye track area and install holdback. Taxi aircraft until completion of launch bar tracking (buffer hook bottomed), both engines shall be turned up to MRT power for a maximum duration of 30 seconds. During this time, testing of one engine IAW F-14 B/D NATOPS procedures shall be performed.
2. After completion of tests run on the first engine, both engines shall be turned down to idle power for a JBD cooldown period of 30 seconds.
3. After the cooldown period, both engines shall again be turned up to MRT power for a maximum duration of 30 seconds. During this time testing of the second engine IAW F-14 B/D NATOPS procedures shall be performed.
4. At completion of the RATS check test, an additional JBD cooldown period of 30 seconds is required prior to launch of an aircraft.
5. A RATS test shall be counted as one RRHB release cycle and counted towards the 1400 cycle RRHB service life. If the aircraft is launched following the RATS check, another cycle (2 total) shall be counted and logged on the RRHB SRC card and data plate.
6. If the aircraft is to be launched following the RATS check, the RRHB is not required to be disconnected from the aircraft prior to launch.

4.6 LAUNCHING HELICOPTERS

4.6.1 Helicopter Launch Procedures.

Helicopter start and spread sequence, rotor engagement and launch will be in accordance with appropriate aircraft NATOPS procedures and shall only occur after the proper signal from a qualified LSE and under positive control of PriFly.

WARNING

Because of the rotor wash and wing-tip vortices produced by CH-53E and MH-53E helicopters, land/launch operations should not be conducted upwind of other aircraft or any unsecured area. Because of this severe hazard, consideration should be given to conducting CH-53E and MH-53E operations from afterdeck spots only.

Note

To reduce UHF transmissions or during EMCON, rotary beacon signals for helicopter operations are found in **Figure 3-1** of the Aircraft Signals NATOPS Manual (NAVAIR 00-80T-113).

For all launches, the air officer shall ensure the relative wind is within the envelope prescribed in the applicable NATOPS flight manual. For night and IMC launches, the nose of the helicopter shall be oriented to the center-line of the angle or axial deck and within the visual parameters established in the respective aircraft NATOPS flight manual. Before launch, with the ship steady on launch course, PriFly will order tiedowns removed. The LSE shall then signal for removal of the tiedowns, ensuring the pilot sees the signal.

WARNING

Tiedowns shall not be removed from a helicopter until the pilot has signified he is ready to launch and the LSE has received permission from PriFly.

Note

Minimum wind over deck requirements change with outside air temperature. Check applicable NATOPS flight manual.

The plane captains or plane handlers after removing tiedowns and chocks shall hold the tiedowns up for the pilot and LSE to see and then clear the area. As tiedowns are being removed, PriFly shall broadcast the relative wind direction and velocity and then activate the appropriate signals (see **Figure 3-1** of Aircraft Signals

NATOPS Manual (NAVAIR 00-80T-113)). Before launching a helicopter, the LSE shall ensure the following:

1. All tiedowns have been removed.
2. The area affected by the helicopter downwash is clear of unnecessary personnel and the area over which the helicopter will pass is clear.
3. Airborne aircraft are well clear. The pilot will not commence takeoff until he has received the launch signal from the LSE and has turned on anticollision light(s).
4. Confirm launching signal/approval from PriFly.
5. Required hover tests following maintenance may require extra clearance area for maneuvering.

The departing helicopter, if SAR capable, shall report **red light** to the controlling agency (i.e., tower, departure, ASAC) upon launch (EMCON permitting). When there is a significant change in the red light or red light is reached, a radio call to the controlling agency should be made.

Unless otherwise directed, helicopters will take departure to port and shall not cross the bow within 5 miles or the stern within 3 miles (see **Figure 3-4**) without specific clearance from the tower.

4.6.2 Helicopter Safety Precautions. The following safety precautions applicable to helicopter operations shall be observed.

1. Personnel shall not be permitted to approach or depart a helicopter while its rotors are being engaged or disengaged.
2. Personnel required to be in the area of helicopters engaging or disengaging rotors shall either stand next to the fuselage or well outside the rotor area.
3. Helicopters should not be taxied on the flight deck.
4. Helicopters shall not be towed or pushed with rotors engaged.
5. Launch/recovery of helicopters while the ship is in a turn should be attempted only when authorized by the carrier commanding officer or

his designated representative. Anticipated wind parameters and ship's heel must be communicated to the helicopter aircraft commander prior to execution.

6. A helicopter shall never be flown over another aircraft on launch.
7. Only spots that afford visual reference to the deck shall be used for night helicopter launches.
8. Helicopter rotors should not be engaged/disengaged if the blades extend over the deck edge.
9. Helicopter rotors should not be engaged/disengaged while the ship is in a turn. Engagement/disengagement attempts while in a turn must be approved by the carrier commanding officer or his designated representative. Anticipated wind parameters and ship's heel must be communicated to the helicopter aircraft commander prior to execution.
10. Helicopter shall not be landed or launched where their engine performances or stability could be affected by turning jet engines.



- In crosswind conditions relative to the axial deck, the indicated winds often vary from those winds actually experienced at flight deck level. Jet exhaust/prop turbulence can adversely affect flight deck level winds. These variances can affect velocity, turbulence, and direction of actual winds that are critical to safe launch of aircraft and must receive consideration prior to granting takeoff clearances.
- Jet exhaust shall not be directed into the path of the aircraft being launched.

4.6.3 Rescue Helicopter Launching Criteria. It is impossible to set specific criteria for launching helicopters under all emergency rescue conditions. Each situation is different, and all factors must be considered to determine if the risk involved is

warranted at the time. To provide guidelines, the following list of factors should be considered.

1. Present weather - Temperature, wind, sea state, etc.
2. Urgency of emergency- Definite, suspected, live, dead, etc.
3. Other rescue vehicles in area - Helicopters, ships, etc.
4. Maneuvers of carrier - Turning, pitching, downwind, etc.
5. Location of helicopter- Bow, stern, elevator, etc.
6. Location of victim(s) in relation to ship.
7. Status of flight deck - Launching, recovering, standby, etc.
8. On night launch, the pilot needs a visual reference and the relative wind on the nose of aircraft.
9. Night adaptation of pilot and crew, if applicable.
10. Warmup of electronic gear.
11. Capabilities of individual pilot.

This list is not to be considered all-inclusive nor preclude the possibility of other variable factors present that may affect the advisability of launching under adverse conditions.

4.7 RESCUE HELICOPTER INFORMATION

The following information should be passed to rescue helicopters by PriFly or other controlling agency as soon as available:

1. Type of mishap (i.e., man overboard, ejection, etc.).
2. Magnetic bearing and distance to emergency area.
3. Surface wind direction and velocity.
4. Ejection altitude if applicable.
5. Number of persons requiring rescue and condition, if known; readback is required.

6. Radio frequency for radar vectors if required; radio frequency and call sign of pathfinder aircraft if utilized; and radio frequency and call sign of the SAR on-scene commander, if applicable.
7. Additional information as necessary. (Use of the SAR frequency should be limited exclusively to passing information necessary to the rescue helicopter pilot.)

WARNING

Rescue swimmers shall not enter the water during night/IMC simulated rescue operations in an open ocean environment.

4.8 DOWNED AND STANDBY AIRCRAFT

4.8.1 Downed Aircraft. Downed aircraft (duds) shall be disposed of in accordance with the prelaunch briefing. Except in case of emergency, they shall be shut down only on signal from a director. Pilots shall remain in duds until the plane captain is on hand and ready to man the cockpit.

4.8.2 Standby Aircraft. All standby aircraft (spares) shall be manned by a full flightcrew unless specific provision to the contrary is included in the air plan. Spares, if not launched, will normally be kept turning up until it becomes apparent that they are no longer needed or until other operational considerations require that they be shut down. In any event, pilots shall not secure engines until directed to do so. When a spare is launched to replace a downed aircraft, PriFly will relay to the pilot the side number of the aircraft he is replacing. Standby helicopters will often be launched to clear the deck for fixed-wing operations. When this occurs, the pilot will proceed directly to the **Delta** pattern and await landing instructions unless directed otherwise.

4.9 RESPOT FORWARD

The pace of the respot forward depends upon how soon the ensuing recovery is expected to begin. If there is no recovery scheduled to follow the launch, it may not be necessary to move the aircraft at all; however, all preparations must be made for an immediate respot forward in case of emergency. The aircraft handling

officer is responsible for requesting taxi pilots as required. Prelaunch briefing should cover the respot forward in detail so that it can be performed expeditiously, safely, and with a minimum of confusion in the event of an emergency.

4.10 EMERGENCY AFTER LAUNCH

4.10.1 Visual Meteorological Conditions. If an emergency requires an immediate landing, the pilot shall prepare to jettison external stores and dump fuel as necessary to lower the aircraft gross weight below the maximum allowable landing weight. He shall advise the tower of the nature of the emergency and his desires. The air officer will inform the bridge of the situation, direct the preparation of the deck, and give the pilot an expected BRC and an estimated **Charlie** time. The expected Charlie time will be based on the time required to clear the deck and get an acceptable WOD for the recovery. The pilot must observe the progress of the turn into the wind and the preparation of the deck. He must attempt to time his approach to avoid arriving at the ramp too early.

4.10.2 Night/Instrument Meteorological Conditions. Should an aircraft have an emergency during departure and require an immediate landing, the departure controller will provide vectors until the aircraft is picked up by an approach or a **final controller**. Every effort shall be made to retain the aircraft on the departure frequency until safely aboard. PriFly and the LSO must be advised immediately of the emergency and the control frequency.

Aircraft with emergencies which do not require immediate recovery will continue normal departure procedures while the departure controller expeditiously acquires positive control. Once acquired, positive control shall be employed until the emergency aircraft has been recovered or diverted.

4.11 LAUNCHING CONDITION AIRCRAFT

Flightcrews for condition aircraft shall be called away early enough to permit a normal preflight inspection, start, warmup, and completion of takeoff checks by the alert time specified in the air plan for the condition of readiness to become effective. After the pilot declares the aircraft ready for flight, it shall be placed in the appropriate aircraft condition of readiness as described in the following paragraphs.

4.11.1 Fixed Wing

4.11.1.1 Condition I. The aircraft shall be spotted on the catapult or in a position affording a clear route to the catapult. Unless otherwise directed by the aircraft handling officer, the aircraft shall be secured with initial (four-point/six-point) tiedown. All necessary starting equipment shall be plugged in and a director, starting crewman, plane captain, arm/dearm crew, and required plane handlers shall stand by the aircraft. The aircraft's crew shall be ready for flight in all aspects, with parachutes, safety belts, shoulder harnesses, radio leads, or other personal equipment attached and adjusted as in flight. The catapult crew shall be on station and alert. Launching accessories shall be on deck ready for immediate use. When ordered by competent authority, the air officer will pass the order over the flight deck announcing system to launch the Condition I aircraft. Aircraft, flight deck, arm/dearm, and catapult crews shall, without awaiting further instructions, go through the normal start and prelaunch procedures. The LSO shall man the platform and the recovery equipment controller shall have all recovery equipment manned. As preparations are made for the launch, the air officer will relay wind information to the launching officer and an initial vector, if available, to the pilot. He shall obtain permission from the bridge to launch and, when all conditions are satisfactory, shall turn on the green rotating beacon, clearing the catapult officer to launch.

4.11.1.2 Condition II. All provisions for Condition I apply, except that flightcrews are not required in the aircraft. They shall, however, be on the flight deck near their aircraft or inside the island structure at the flight deck level.

4.11.1.3 Condition III. Flightcrews shall be in full flight gear, briefed, and standing by the ready rooms. Starting equipment shall be immediately available, and flight deck and catapult crews shall be standing by near their stations.

4.11.1.4 Condition IV. This is similar to Condition III except that minor maintenance may be performed on the aircraft if no delay in launch is involved.

4.11.2 Helicopters

4.11.2.1 Condition I. The aircraft shall be spotted for immediate launch. It shall be headed into the relative wind, with rotor blades spread, starting equipment plugged in, and a LSE, starting crewman, plane captain, and required plane handlers standing by. Unless otherwise directed by the aircraft handling officer, at least four tiedowns shall be attached to the aircraft. The flightcrew shall be ready for launch in all respects, with all personnel equipment attached and adjusted as in flight. When the air officer passes the word to stand by to launch the Condition I helicopter(s), engines shall be started without further instructions; however, rotor engagement and launch shall be positively controlled by PriFly.

4.11.2.2 Condition II. The same conditions apply as for Condition I, except that flightcrews shall stand by in the ready rooms.

4.11.2.3 Condition III. Main rotor blades may be folded and the aircraft need not be in position for immediate launch; however, it must be parked so as to allow direct access to a suitable launch spot. A towbar shall be attached to the aircraft and a specific LSE, tractor driver, handling crew, and starting crewman shall be designated and assigned to each helicopter. These personnel must be thoroughly briefed so that when the order is given to prepare to launch, the aircraft can be safely and expeditiously moved into position and readied for launch. Flightcrews should be briefed for the launch and be standing by in a designated location.

4.11.2.4 Condition IV. This is similar to Condition III except that minor maintenance may be performed on the aircraft if no delay in launch is involved.

Alert 5	Condition I
Alert 15	Condition II SEE NOTE
Alert 30	Condition III
Alert 60	Condition IV
Note	
Alert SAR helicopter in Condition II may be folded provided the primary SAR helicopter is airborne. See section 4.11.2.2	

4.11.2.5 Recommended Deck Lighting Configuration for Helicopter NVG Aided Takeoff and Landing.

- Blue Deck Lights ON
- Overhead Sodium Oxide (SOX) Light ON

Beacon Lights	ON
PLAT IR Flood	OFF
Red Deck Status Lights	OFF
Centerline Lights	OFF
Landing Area Lights	OFF
Drop Lights	OFF
IFLOLS/MOVLAS	OFF

Note

SOX lights cause minimal NVD blooming and negate the need for a qualified NVD-LSE while providing ample lighting for flight deck crews.

4.12 CONTROL OF DEPARTING AIRCRAFT

Primary responsibility for adherence to the assigned departure rests with the pilot; however, advisory control shall normally be exercised, with a shift to positive control as required by weather conditions, upon request, or when the assigned departure is not being adhered to. After launch, CATCC shall:

1. Record data as required on status boards.
2. Ensure communications and positive track are established with all aircraft to the extent possible under existing EMCON conditions.
3. Request NAVAID checks as necessary.
4. Maintain advisory control of departing point-to-point flights until pilots shift to en route frequencies and of other aircraft until control is accepted by CDC or another controlling agency.
5. Before releasing aircraft to another controlling agency, give each pilot (or flight leader) any pertinent information, such as changes in composition of flight, changes in PIM, or changes in mission.
6. When transferring control to CDC, give CDC the range and bearing of the aircraft being transferred, and ensure CDC acknowledges assumption of control.
7. File flight plans as necessary.

4.12.1 Departure Radials. Departure radials are based on the use of TACAN for providing lateral separation. The minimum standard separation of departure radials under instrument conditions is 20°.

Assignment of departure radials is normally dependent on the following:

1. Mission of the aircraft
2. Number of carriers in the formation
3. Topographical features in the area
4. Those radials reserved for emergencies, letdowns, or helicopter holding.

Direct routing will be utilized as much as possible in order to lessen delay time in the execution of departures.

4.12.2 Departure Communication Procedures

4.12.2.1 Launch Frequencies. Aircraft shall normally launch on the departure frequency that shall be monitored by the tower. Condition and CAP launches will be on a frequency designated by CDC and monitored by the tower.

4.12.2.2 Single-Frequency Departures. These departures are highly desirable and shall be utilized whenever possible. Where single-frequency departures are not possible, single-piloted aircraft shall not be required to change radio frequencies or IFF/SIF codes after launch until at least 2,500 feet of altitude has been reached and the aircraft is in a climbing, wings-level attitude. Single-piloted aircraft that are assigned operating altitudes below 2,500 feet shall not change frequencies or IFF/SIF codes until a level attitude and cruise configuration have been attained. Guard channel shall be monitored at all times.

4.12.2.3 Case III Departure Voice Reports. These reports will vary with weather, state of training, EMCON condition, and the type of operation. The following reports are commonly used:

1. Airborne
2. Passing 2,500 feet
3. Arcing

4. Established outbound (on assigned radial)
5. **Popeye**, with altitude (see Note)
6. On top, with altitude
7. Kilo.

Note

When in IMC, Popeye will be a mandatory report for departing aircraft passing FL 180 (or assigned departure altitude if lower) if not on top.

4.12.2.4 Lost Communications During Departures. If communications are lost during departure, squawk Modes I and III as listed in **Figure 3-2**. If in VMC when communications are lost, remain VMC. If able, return to the ship by visual means for recovery. If on top/IMC, proceed to the applicable emergency marshal and commence a descent to depart that fix at **EEAT**.

4.12.2.4.1 Good Azimuth and No DME. In the event of lost communications and a loss of TACAN DME, the following departure procedure shall be followed utilizing TACAN azimuth. Continue with the prebriefed departure; utilize DR procedures to maintain the appropriate arc until reaching assigned departure radial. Proceed to approximately 50 miles, reverse course, proceed inbound on the assigned departure radial at the emergency marshal assigned altitude, and enter overhead holding using the prebriefed expected final bearing for proper holding orientation. Conserve fuel and be alert for joinup. If not joined by an escort aircraft, commence approach at **EEAT**. Use prebriefed expected final bearing to determine outbound and inbound tracks.

4.12.2.4.2 Good Azimuth and Good DME. All aircraft will continue with prebriefed departure, climbing outbound on departure radial unless modified by CATCC or until reaching 50 miles and commence left-hand holding between 40 to 50 miles. After holding for 30 minutes, proceed inbound on the departure radial, climbing or descending to the emergency marshal assigned altitude. When reaching the distance prescribed for emergency marshal, arc in the shortest direction until reaching the assigned emergency marshal fix, enter holding, and commence approach at assigned **EEAT**.

Note

Helicopters experiencing lost communications should remain at or below 300 feet, arc to enter starboard Delta, and execute lost communications procedures in accordance with **Figure 5-8**.

4.12.3 Fixed-Wing Departures/Rendezvous

4.12.3.1 Case I Departure. This departure may be utilized when it is anticipated that flights will not encounter instrument conditions during departures and rendezvous with weather conditions no lower than 3,000 feet and 5-nm visibility.

4.12.3.1.1 Jet/Turboprop Aircraft. After a clearing turn, proceed straight ahead paralleling the BRC at 500 feet until 7 nm. Aircraft are then cleared to climb unrestricted in visual conditions.

4.12.3.2 Case I Rendezvous. Rendezvous shall conform to air wing doctrine.

4.12.3.3 Case II Departure. For departure, visual conditions at the ship may exist down to a ceiling of 1,000 feet and visibility of 5 miles. Launch shall be on departure control frequency.

4.12.3.3.1 Jet Aircraft. After a clearing turn, proceed straight ahead at 500 feet paralleling the BRC. At 7 nm, turn to intercept the 10-nm arc, maintaining visual conditions until established on the departure radial. The 500-foot restriction is lifted after 7 nm if the climb can be continued in visual conditions. Jets shall maintain 300 knots until VMC on top.

4.12.3.3.2 Turboprop Aircraft. After a clearing turn, parallel the BRC at 500 feet. At 6 nm, turn to intercept the 7-nm arc, maintaining visual conditions until established outbound on the departure radial. Maintain 500 feet until 12 nm on the departure radial.

Note

COD aircraft will depart straight ahead unless otherwise directed and maintain 500 feet until 12 nm.

4.12.3.4 Case III Departure. This departure shall be used whenever existing weather at the ship is below Case II departure minimums and during all night operations except as modified by the OTC or

commanding officer. Case III departures are compatible only with Case III recoveries. The launch shall be on departure control frequency. A minimum launch interval of 30 seconds shall be used between aircraft. When possible, a 60-second interval will be provided when launching a jet aircraft following a turboprop.

WARNING

- The air officer must be acutely aware of the responsibility to ensure the initial separation between bolter/waveoff and departing aircraft during CARQUAL and cat-trap-cat evolutions.
- CATCC's restricted radar coverage (blindspot) ahead of the ship requires aircrew to exercise good lookout doctrine upon departure.

4.12.3.4.1 Jet Aircraft. Climb straight ahead accelerating at 300 knots crossing 5 nm at 1,500 feet or above. At 7 nm, execute turn to fly the 10-nm arc until intercepting the departure radial.

4.12.3.4.2 Turboprop Aircraft. Climb straight ahead to 1,000 feet, accelerating to 250 knots after level-off. At 5 nm, turn to intercept the 7-nm arc and arc to the departure radial. Maintain 1,000 feet until 12 nm on the departure radial.

Note

COD aircraft will depart straight ahead unless otherwise directed and maintain 1,000 feet until 12 nm.

4.12.3.5 Case II/III Rendezvous. Case II/III aircraft shall rendezvous between 20 and 50 miles from the carrier on the left side of the departure radial at a prebriefed altitude (for example, 1,000 feet above the cloud layer). This does not preclude other visual rendezvous procedures as directed by air wing doctrine.

4.12.3.6 Fixed-Wing IMC at Altitude. The first aircraft of each flight shall report to departure control passing FL 180 if not on top. Unless operational

necessity dictates otherwise, the departure controller shall assign aircraft that are IMC and appropriate altitude; for example, with four aircraft expected on the same departure radial, altitude assignments would be as follows:

1. First aircraft - FL 220
2. Second aircraft - FL 210
3. Third aircraft - FL 200
4. Fourth aircraft - FL 190.

Note

Carrier-based aircraft shall fly MSL altitudes below 18,000 feet MSL and [flight levels](#) at and above 18,000 feet MSL unless regional supplementary procedures, as published in FLIP Planning, dictate otherwise.

4.12.4 Helicopter Departure

4.12.4.1 Case I and Case II. Helicopters shall clear the control zone as directed by the tower. When departing for operations within the control zone (for example, SAR), they shall remain under control of the tower or other designated controlling agency.

4.12.4.2 Case III. Whenever possible, helicopters shall be maintained as a flight beneath the clouds. If unable to remain beneath the clouds, they shall proceed individually to prebriefed departure fixes. After takeoff, they shall climb straight ahead to between 200-300 feet (unaided), 150-300 feet (NVD aided), or as assigned by CATCC, and arc within 3 miles to intercept the assigned departure radial. Helicopters being launched from the angled deck will not cross the bow when fixed-wing aircraft are being launched. SAR helicopters will arc to the SAR pattern (see [paragraph 3.6](#)) if able to remain beneath the clouds. If the SAR helicopter is unable to remain beneath the clouds, the procedure presented above shall be carried out under positive control of CATCC and position will be taken in helicopter marshal (see [Figure 5-4](#)). The climb to departure altitude will be commenced on the departure radial outside 12 nm.

CHAPTER 5

Recovering Aircraft

5.1 ARRIVAL PROCEDURES

5.1.1 Entering the Carrier Control Area. Inbound flights shall normally be turned over to marshal control for further clearance to the marshal pattern. Aircraft that were unable to check in with strike, mission, or marshal control because of communication difficulties should proceed as directed in [Figure 3-1](#).

WARNING

Aircraft recovering aboard the CV with fuel other than JP-5 shall notify the appropriate authority in accordance with ship/air wing SOP prior to recovery.

5.1.2 Arrival Information. The flight leader shall provide the following information when checking in with marshal control:

1. Position
2. Altitude
3. Fuel state (low state in flight)
4. Total number of aircraft in flight (lineup)
5. Type approach requested — [UTMs](#) sweet (if applicable)
6. Other pertinent information such as navigational aid status, hung or unexpended ordnance, weather, etc., that may affect recovery
7. COD [load report](#).

5.1.3 Transient Helicopters. Transient helicopters approaching the carrier for landing shall contact marshal control at least 25 miles out.

During Case III, marshal control will clear helicopters to CV-3 holding or starboard [delta](#) as requested. Helicopters unable to check in with marshal control because of communications difficulties should proceed as directed in [Figure 3-1](#).

5.2 CASE I

This approach may be utilized when it can be anticipated that flights will not encounter instrument conditions at any time during the descent, break, and final approach. A ceiling of 3,000 feet and 5 miles visibility within the [carrier control zone](#) is required. The flight leader retains full responsibility for proper navigation and separation from other aircraft. All returning flights will check in with marshal control when entering the carrier control area or as soon as they are released by another controlling agency. Marshal control shall acknowledge the check-in and provide the following information:

1. Case recovery
2. Expected BRC
3. Altimeter
4. Expected “[Charlie](#)” time (if other than briefed).

Aircraft shall normally be switched to tower control at 10 nm after reporting the ship in sight (“see you”).

5.2.1 Jet/Turboprop Aircraft Port Holding/Spin Pattern. The jet and turboprop [port holding pattern](#) is a left-hand pattern tangent to the BRC or expected BRC with the ship in the 3-o’clock position and a maximum diameter of 5 nm. Flights shall be established at their assigned port holding pattern altitude 10 nm prior to entering the pattern. Entry shall be tangential with wings level. Minimum altitude assignment shall be 2,000 feet MSL. A minimum of 1,000 feet vertical separation between holding altitudes shall be maintained. The squadron/ unit recovery order and altitude assignment shall be as promulgated by

ship/air wing doctrine. All aircraft shall maintain the prescribed separation and landing order in the port holding pattern and throughout the descent.

Departure from the port holding pattern for break entry shall be accomplished aft of the ship's beam. Descent to the break from the port holding pattern is commenced by the lowest aircraft or flight in time to meet the **ramp time**. This descent should be planned so as to arrive at the initial (3 miles astern, 800 feet) wings level, paralleling the BRC.



Flight leaders must exercise caution to avoid aircraft in the tanker pattern.

The flight leader shall either execute a normal break or **spin** for all or a portion of his flight, depending upon the number of aircraft in the landing pattern. A spin should normally be initiated at the bow. The spin pattern shall be flown at 1,200 feet within 3 nm of the ship. A maximum of six aircraft shall be in the landing pattern at one time. This number may be modified by the air officer. No aircraft shall break more than 4 miles ahead of the ship. Pilots must exercise caution to avoid departing aircraft and aircraft in the **starboard holding pattern**. Should a Delta be given after commencing descent from the port holding pattern, but prior to entering the landing pattern, aircraft shall climb or descend as required and enter the spin pattern (1,200 feet) unless specifically directed otherwise. Aircraft in the landing pattern shall continue to maintain proper interval, flying the landing pattern at 600 feet until otherwise directed. Flights directed to spin or reenter the port holding pattern shall climb only on the upwind or crosswind leg ahead of the ship's beam. Aircraft reentering the break from the spin pattern have priority over aircraft entering from the port holding pattern.

5.2.2 COD Aircraft. The starboard holding pattern shall be a right-hand racetrack pattern between 45° and 135° relative at 500 feet or at 1,000 feet if approved by the air boss, oriented on the ship's heading with the closest point of approach no closer than 1 nm. When ready, the air officer will give a Charlie to aircraft in the starboard holding pattern.

5.2.3 Helicopters. Helicopters shall proceed to the starboard holding pattern at 300 feet or below (refer to **Figure 5-6**). Unless previously briefed to the contrary, when more than one helicopter is operating in the holding pattern, all helicopters shall fly a right-hand pattern at 300 feet maintaining 80 knots.

5.2.4 Landing Pattern Entry. Entry to the break shall be made at 800 feet. All breaks shall be level. Letdown to 600 feet shall commence when established downwind. Descent to these altitudes shall be completed before reaching the 180° position. From launch, bolter, or touch and go, corrections to parallel the BRC shall not be attempted until a definite climb has been established. Climb to pattern altitude should normally be completed prior to commencing the turn to the downwind leg. Normal interval shall be taken on other aircraft in the pattern.

5.2.5 Voice Reports. Flight leaders shall make the following voice reports.

POSITION	REPORT
Descending from the port holding pattern	"Commencing"
Three miles astern	"Initial"
Entering spin pattern (when applicable)	"Spinning"
Departing the landing pattern to reenter port holding.	"Departing _____ nm upwind"

5.2.5.1 Low Visibility Voice Reports: Anyone can recommend low visibility reports. The following calls shall be used by flight leaders upon Air Officer's announcement of "99 low-vis-calls."

- "Commencing"
- "Initial"
- "Breaking at ___ nm"
- "Departing at ___ DME"
- "Spin 90"

Flight leaders should amplify low-vis calls as required to add to overall situational awareness and safety of flight (e.g. - "501, commencing from angels 4 with 2").

5.2.6 ZIP LIP. Case I procedures shall apply, except for elimination of prescribed voice reports. The flight leader first in recovery order shall observe the deck and plan his recovery to be at the ramp as soon as a ready deck is available. Should unprogrammed, unbriefed, or straggler flights arrive for recovery, ZIP LIP shall be broken as required to ensure safety of flight.

Note

ZIP LIP shall be broken anytime an apparent safety of flight situation develops.

5.2.7 Drag. If a straight-in approach (drag) is requested, it shall be initiated at sufficient distance astern for the aircraft to be established positively on glidepath and approach airspeed at a minimum of 1-1/2 nm for jet/turboprop aircraft.

5.2.8 Upwind Turn. Upon reaching a safe altitude, the upwind turn is commenced to establish the proper interval on known traffic.

Note

Case I recoveries shall not be conducted concurrently with Case III departures.

5.3 CASE II

This approach shall be utilized when weather conditions are such that the flight may encounter instrument conditions during the descent, but visual conditions of at least 1,000 feet ceiling and 5 miles visibility exist at the ship. **Positive control** shall be utilized until the pilot is inside 10 nm and reports the ship in sight. During Case II recoveries, **CATCC** shall be manned and prepared to assume control of a Case III recovery in the event weather conditions deteriorate. The maximum number of aircraft in the landing pattern is limited to six.

Note

Case II recoveries shall not be conducted concurrently with Case III departures. Should doubt exist regarding the ability to maintain VMC, Case III recoveries shall be utilized.

Penetrations in actual instrument conditions by formation flights of more than two aircraft are not

authorized. Flight leaders shall follow Case III approach procedures outside of 10 nm. When within 10 nm with the ship in sight, flights will be shifted to tower control and proceed as in Case I. If the flight does not have the ship in sight at 10 nm, the flight may descend to not less than 800 feet. If a flight does not have the ship in sight at 5 miles, both aircraft shall be vectored into the bolter/waveoff pattern and action taken to conduct a Case III recovery for the remaining flights.

Note

Weather conditions permitting, helicopters may be assigned Case I procedures concurrently with Case II and III fixed-wing aircraft operations.

5.4 CASE III

This approach shall be utilized whenever existing weather at the ship is below Case II minimums and during all flight operations conducted between one-half hour after sunset and one-half hour before sunrise except as modified by the OTC or carrier commanding officer. Night/IMC Case III recoveries shall be made with single aircraft. Section approaches will be approved only when an emergency situation exists. Formation penetrations/ approaches by dissimilar aircraft shall not be attempted except in extreme circumstances where no safer options are available to effect a recovery.

Note

Case III recoveries may be conducted concurrently with Case I and II launches.

At night during VMC conditions, helicopters may be cleared to the starboard holding pattern. The same airspeed and spacing restrictions will apply as in day VMC.

5.4.1 Marshal Procedures.

5.4.1.1 Jet/Turboprop Aircraft. The primary TACAN marshal fix is the 180° radial relative to the expected **final bearing** at a distance of 1 mile for every 1,000 feet of altitude plus 15 miles (angels +15). The holding pattern is a left-hand, 6-minute racetrack pattern. The inbound leg shall pass over the holding fix. In no case will the base altitude be lower than 6,000 feet.

5.4.1.2 Helicopters. The primary TACAN marshal is the 110° radial relative to the expected final

bearing at a distance of 1 mile for every 500 feet of altitude, starting at 1,000 feet and 5 miles. The holding pattern is a right-hand racetrack pattern with 2-nm legs. The inbound leg shall pass over the holding fix.

5.4.1.3 Emergency Marshal Fixes. All fixed-wing aircraft are issued an **emergency marshal** radial 150° relative to the expected final bearing at a distance of 1 mile for every 1,000 feet of altitude plus 15 miles (angels +15). Lowest altitude for assignment is 6,000 feet for turboprop/jet. Holding sequence is jets, then turboprops. Holding procedures are right-hand, 6-minute racetrack patterns. The inbound leg shall pass over the holding fix. Helicopter emergency marshal radial is the same as normal helicopter marshal radial with helicopter emergency holding normally commencing at 7 miles.

5.4.1.4 Overhead Marshal. Overhead marshal may be utilized as geographical or operational circumstances necessitate. The assigned inbound magnetic heading to the holding fix should coincide with the outbound magnetic radial of the approach. If overhead marshal is used as the emergency marshal fix, **EEATs** should be every other minute.

5.4.1.5 En Route Radar Approaches. In the event an aircraft or flight cannot reach the marshal point in time to make an assigned approach time, an en route radar approach may be used to place the flight in the proper approach sequence.

The marshal/approach controller shall employ positive radar control and provide the pilot the purpose and a brief description of the intended penetration whenever possible.

5.4.1.6 Marshal Altitude Assignment. Every effort should be made to anticipate weather conditions and provide marshaling in visual conditions if practical. Aircraft below an overcast should not be required to climb into the overcast to comply with base altitude limits if marshal control can safely exercise control below the overcast. Those aircraft above an overcast should be assigned altitudes above the overcast and retained in formation where possible. Formation flights shall be limited to a maximum of four aircraft at any one assigned altitude. Under instrument conditions, a section of two aircraft is the maximum number authorized in any one flight.

5.4.1.7 Marshal Altitude Separation.

Fixed-wing aircraft will normally have a minimum of 1,000 feet vertical separation. Vertical separation may be reduced to 800 feet when inside 12 nm. Helicopters shall be separated by a minimum of 500 feet vertically.

5.4.1.8 Marshal Airspeed. Aircraft will normally fly at airspeeds in accordance with the applicable aircraft NATOPS flight manual.

5.4.1.9 Bow-On-Recovery. A bow-on-recovery occurs when the marshal radial is located ahead of the carrier. Significant potential conflict exists between departing and recovering aircraft due to airspace constraints associated with opposite direction traffic flow and the existence of an AN/SPN-43 radar “blind spot” ahead of the ship. CATCC shall communicate bow-on-recovery to all aircrew as soon as bow-on-recovery is determined. Departing aircraft will receive positive control to ensure departing aircraft remain clear of recovering aircraft until course conflict is resolved. CATCC shall provide recovering aircraft positive control and sequencing to ensure adequate separation is maintained.

5.4.2 Marshal Instructions. Marshal control shall ensure the following information has been provided each aircraft prior to entering marshal:

1. Case recovery
2. Type approach
3. Expected final bearing
4. Altimeter
5. Marshal holding instructions
6. **Expected approach time**
7. Expected approach button
8. Time check
9. Vector to marshal (if required)
10. Multiple marshal stack information (radials/altitudes).

Note

When overhead marshal is utilized, the assigned outbound penetration bearing shall

be updated during recovery to maintain a minimum of 25° clockwise from the reciprocal of the final bearing.

5.4.3 General Instructions. The following information shall be provided prior to commencing the penetration/approach:

1. Case recovery
2. Type approach
3. Final bearing
4. Weather and deck conditions
5. **Divert** field/fuel data
6. Time hack (30 seconds minimum) using GPS time
7. USW datum (if applicable)
8. Density altitude (if applicable)
9. MOVLAS recovery, including station number and location (tactical situation permitting)
10. COD **RETRO report** (if applicable).

To reduce radio traffic, items of general or collective interest may be transmitted as a “99” broadcast by marshal or **approach control**.

5.4.4 Departing Marshal. Each pilot shall adjust his holding pattern to depart marshal at the assigned **EAT**. Early or late departure shall be reported to marshal control immediately so that control adjustments can be accomplished if required.

5.4.5 Initial Separation. Unless weather or operating circumstances dictate otherwise, aircraft departing marshal will normally be separated by 1 minute. Adjustments may be directed by CATCC, if required, to ensure proper separation.

5.4.6 Frequency/IFF/SIF Changes. Changes in radio communication frequencies, IFF and/or SIF mode/code that require accomplishment by the pilot should be made no later than **platform** except under emergency conditions. The aircraft shall be in straight

and level flight should such changes be required below an altitude of 2,500 feet.

5.4.7 Instrument Approach Procedures. The approaches described in this paragraph are designed primarily for single-carrier operations; however, with slight modification, they can be used for the following:

1. Multiple-carrier operations
2. Letdown under reduced navigation and control
3. Letdown using SAR as navigational aids with AEW control
4. Recoveries during EMCON conditions.

The approach charts (**Figures 5-1 to 5-4**) are designed for use with all aircraft carriers regardless of weather conditions. It is incumbent on each ship to utilize the standard approaches so that pilots may safely transition from ship to ship or from visual to instrument conditions with a minimum change in operating procedures.

5.4.7.1 Approach Minimums. The commanding officer shall establish approach minimums that reflect significant changes in operational capabilities, such as may be occasioned by decreased proficiency of the CATCC or embarked air wing. However, absolute minimums are as provided in **Figure 5-5** (see LSO NATOPS Manual for CARQUAL minimums).

When a suitable **bingo** field is available, aircraft shall not commence an approach if the reported weather is below the minimums in **Figure 5-5** unless it has been determined that the aircraft has sufficient fuel to proceed to the bingo field in the event of a missed approach.

5.4.7.2 Penetration/Approach

1. Jet/turboprop aircraft shall descend at 250 knots and 4,000 feet per minute until platform is reached, at which point the descent shall be shallowed to 2,000 feet per minute. Unless otherwise directed, aircraft shall commence transition to a landing configuration at the 8-nm fix.
2. Helicopters shall descend at 90 knots and 500 feet per minute from marshal, crossing 145° relative

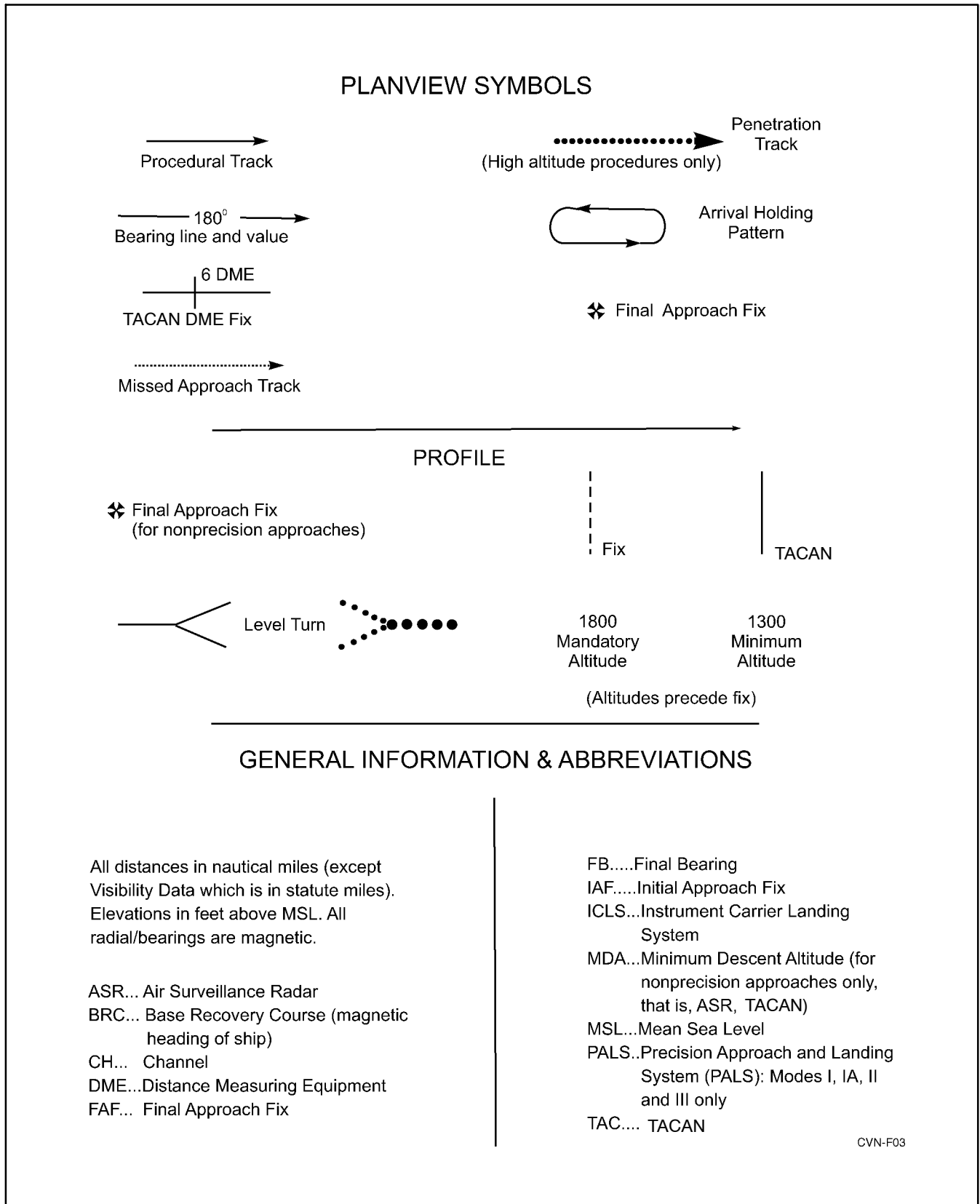
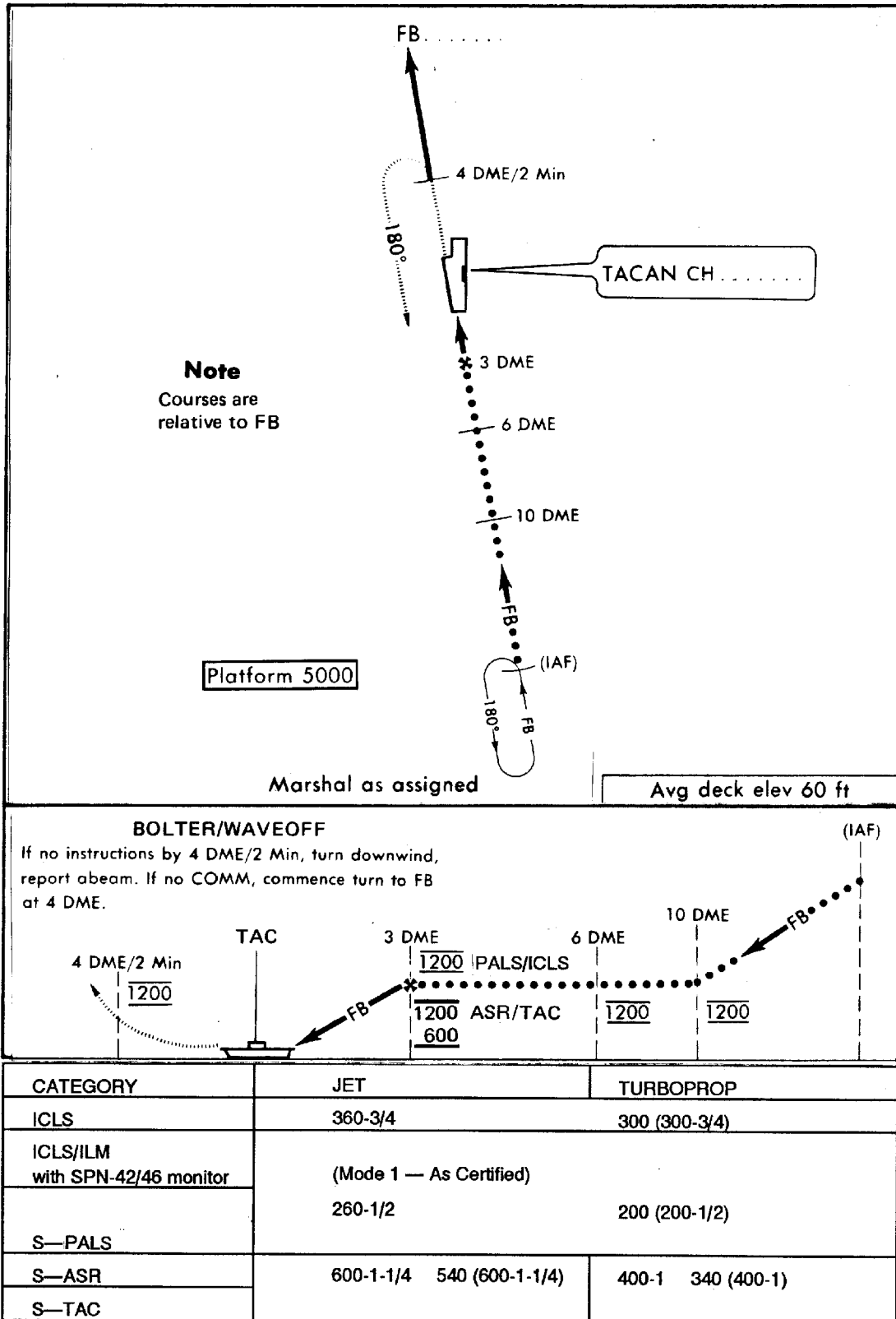
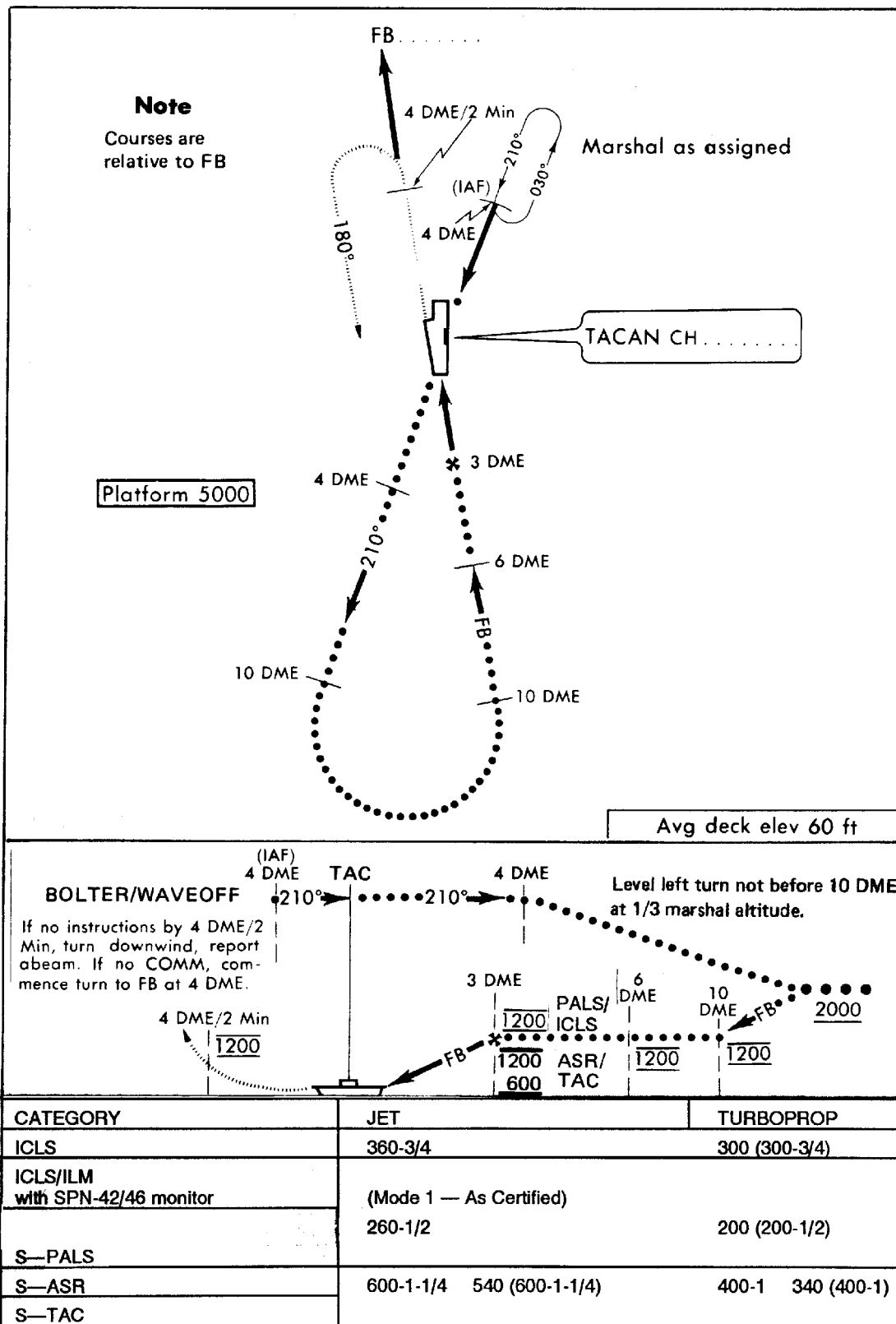

Figure 5-1. Legend Chart for Aircraft Carrier Instrument Approach Procedures



CVN-F04

Figure 5-2. Approach Chart CV-1 TACAN (Jet and Turboprop)



CVN-F05

Figure 5-3. Approach Chart CV-2 TACAN Overhead (Jet and Turboprop)

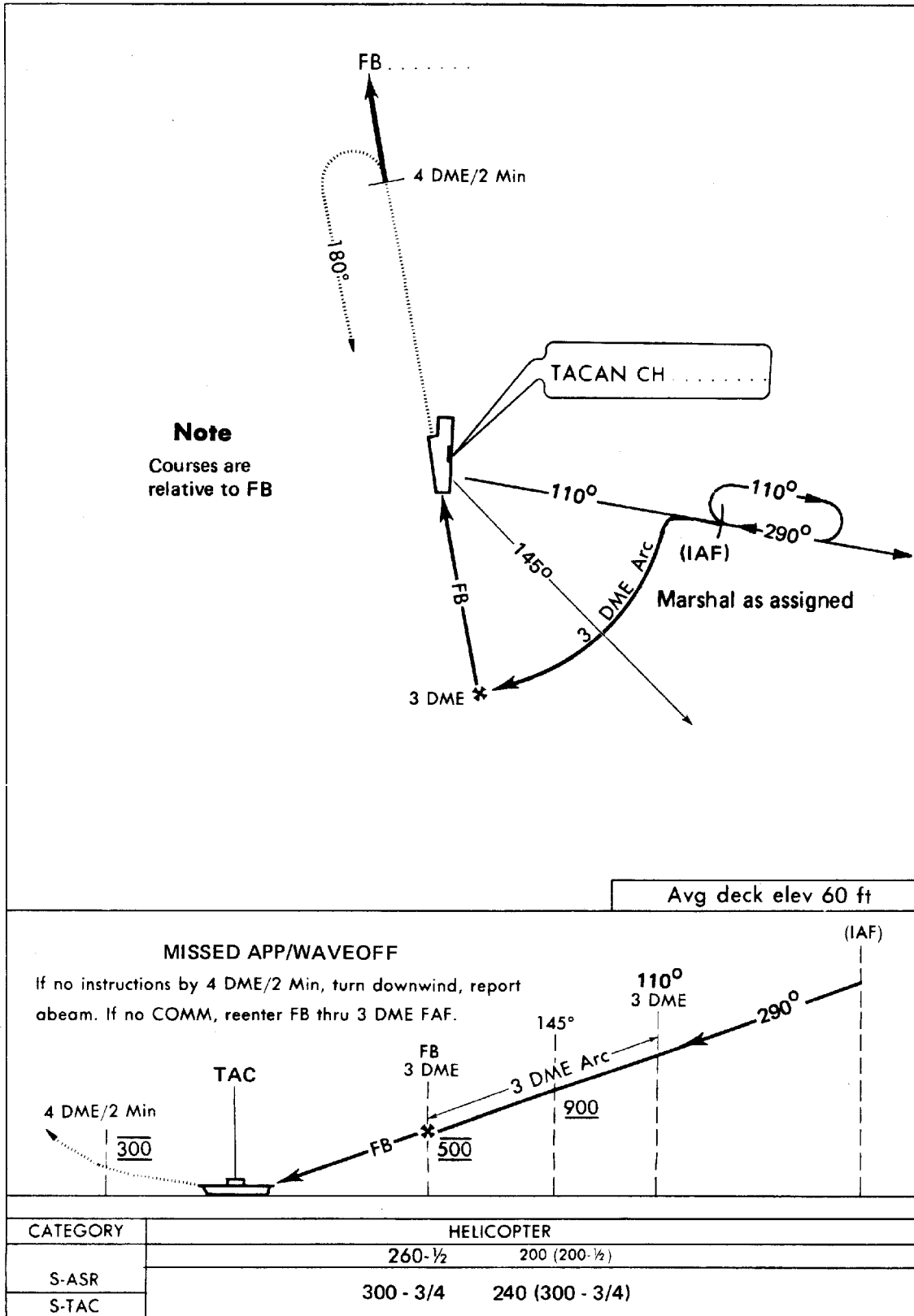

CVN-F06

Figure 5-4. Approach Chart CV-3 TACAN (Helicopter)

to the final bearing at or above 900 feet. Unless otherwise directed, helicopters shall commence transition to a landing configuration prior to the 3-nm fix.

5.4.7.3 Correcting to the Final Bearing

1. Jet or turboprop aircraft on the CV-1 approach will correct from the marshal radial to the final bearing at 20 miles in the following manner:
 - a. The pilot shall make a gradual correction when the final bearing is within 10° of the reciprocal of the marshal radial.
 - b. The pilot shall turn 30° when the final bearing is greater than 10° from the reciprocal of the marshal radial. If not established on the final bearing at 12 miles, the pilot shall fly the 12-mile arc until intercepting final bearing.

2. Aircraft on the CV-2 approach shall correct to the final bearing in the following manner:
 - a. If final bearing decreases, fly 90° of penetration turn and arc to the new final bearing.
 - b. If final bearing increases, fly the standard penetration turn continuing to intercept the new final bearing prior to the 10-mile DME fix.

5.4.7.4 PALS Mode I Approach (With AN/ARA-63/AN/ARN-138 Monitor.) Aircraft conducting PALS Mode I approaches with ceiling and visibility less than 200 feet and/or 1/2 mile must be equipped with an operable independent monitor (AN/ARA-63/AN/ARN-138). For those qualified aircraft equipped with AN/ARA-63/AN/ARN-138 ICLS flying CCA approaches to a AN/SPN-41 certified ship, the following procedures shall be followed:

AIRCRAFT	APPROACH	MINIMUMS
JET	NON-PRECISION	600-1-1/4
	ICLS	300-3/4

AIRCRAFT	APPROACH	MINIMUMS
	ICLS/ILM W/SPN-42/46 MONITOR	200-1/2
	MODE I	AS CERTIFIED
	MODE IA, II, IID, IIT, III	200-1/2
TURBOPROP	NON-PRECISION	400-1
	ICLS	300-3/4
	ICLS/ILM W/SPN-42/46 MONITOR	200-1/2
	MODE II/IIT III	200-1/2
HELICOPTER	NON-PRECISION	300-3/4
	MODE III	200-1/2
Note		
<ul style="list-style-type: none"> • PALS Mode I qualified aircraft without an operating ILM may be certified to minimums of 200-foot ceiling and 1/2-nm visibility. • PALS Mode I qualified aircraft with an operating ILM display (ILM displayed on pilot's HUD in single-piloted aircraft or ILM displayed to pilot in command in single-piloted aircraft with side-by-side seating occupied by pilot in command and an assisting NFO) may be certified to minimums less than 200-foot ceiling and 1/2-nm visibility. 		

Figure 5-5. Approach Weather Minimums

1. Jet aircraft shall pass through the 6-mile DME fix at 1,200-foot altitude, 150 knots, and in the landing configuration and commence slowing to final approach speed. The pilot should engage aircraft APC and AFCS. Normally between 4 to 8 miles, the pilot will receive via data link a landing check discrete signal to indicate positive

data-link communications between aircraft and ship.

2. The final controller will acquire the aircraft between 3.5 and 8 miles and the PALS ready/lock-on discrete light will illuminate. At that time, the final controller shall report lock-on with range, verify needles, issue instructions as necessary for the aircraft to intercept the centerline, and instruct the pilot to report "coupled."
3. At lock-on, the pilot selects PALS display (agreement of aircraft needles and PALS display will verify PALS is locked on correctly to the aircraft). For example: "201 lock-on, 5 miles. Say needles." The pilot shall report needle position. For example: "201, needles up and right." The controller reports, "Concur report coupled."

WARNING

The controller shall not transmit commands until the pilot has reported "coupled."

Note

If aircraft is unable to couple or uncouples, continue approach Mode II, ICLS, Mode III.

4. The final controller shall report sending commands. The command control discrete light will illuminate, indicating the PALS system is sending command signals via data link. The pilot shall acknowledge receiving data-link commands by reporting "command control." Thirty seconds coupled flight should be flown prior to intercepting glidepath.
5. The final controller shall advise the pilot when "approaching tipover" (glidepath) and should issue range each mile. At tipover, the pilot should switch to ILM, if available, to verify agreement of ILM and AN/SPN-42/46 displays. The ILM shall be used to monitor the approach to PALS Mode I minimums. ILM and AN/SPN-42/46 displays shall agree to within 2 to 3 needle widths until reaching PALS Mode I minimums.
6. The final controller shall advise the pilot at minimums unless the LSO has previously

assumed responsibility. The pilot shall respond with "ball" report and include the word "coupled." For example: "301 Hornet ball, five point three, coupled." Expect ILM needle deviation errors inside one-quarter nm from touchdown. Use the Fresnel lens as the primary monitor inside PALS Mode I minimums.

WARNING

- PALS discrete lights shall be closely monitored throughout the approach.
- The CCA Officer shall suspend Mode I approaches when PALS Certification/Verification restrictions (i.e., WOD limits, deck motion parameters, etc.) are exceeded.

5.4.7.5 PALS Mode IA Approach (ILM Not Required).

Mode IA approaches are conducted the same as Mode I except the pilot shall uncouple at or prior to reaching approach minimums and report "uncoupled." If the pilot uncouples at "ball" call, he shall include the word "uncoupling" in the ball report. For example: "201 uncoupling, hornet, ball, five point three, manual/auto." When the pilot reports uncoupling, the controller shall downgrade the PALS to Mode II.

5.4.7.6 PALS Mode II Approach (ILM Not Required)

1. Mode II approaches are conducted the same as Modes I/IA until receipt of PAL ready/lock-on discrete light. At that time, the controller shall report lock-on with range, verify needle presentation, and issue instructions as required. For example: "201, lock-on, 5 miles, say needles." The pilot shall report needle position. For example: "201, needles up and right." The controller shall concur or downgrade the approach to ICLS or Mode III and advise the pilot. For example: "201, concur" or "201, disregard needles, downgrade, fly Bullseye or Mode III." The controller shall monitor the approach, advise the pilot when approaching glidepath, and should inform him of range each mile. The controller shall advise the pilot when at minimums unless the LSO has previously assumed responsibility. The pilot shall respond with a ball report.

2. PALS **Mode IIT approach** is a training approach using needles instrument presentation (Mode II) as well as Mode III information.

5.4.7.7 PALS Mode IID Approach (ILM Not Required). For those qualified aircraft equipped with Mode IID (flight director) flying CCA approaches to a Mode IID certified ship, the following procedures shall be followed:

1. Mode IID approaches are conducted the same as Modes I/IA/II until receipt of PALS ready/lock-on discrete light. After receipt of PALS ready/lock-on discrete light, the final controller shall report lock-on with range, verify needles, and issue instructions as necessary for the aircraft to intercept the centerline.
2. At lock-on, the pilot selects PALS display (agreement of aircraft needles and PALS display will verify PALS is locked on correctly to the aircraft). For example, "101, needles up and right." The controller shall concur and report, "Concur, sending flight director", or, "Disregard needles, downgrade Mode III."

Note

If aircraft is unable to receive flight director data or if receipt of flight director data is terminated, continue Mode II or Mode III.

3. When the controller enables the flight director mode, the flight director symbol is automatically displayed on the aircraft HUD. The pilot shall acknowledge receiving the data-link signals by reporting, "Receiving flight director."
4. The final controller shall advise the pilot when approaching glidepath and should issue range with each mile. The final controller shall advise the pilot at minimums unless the LSO has previously assumed responsibility. The pilot shall respond with a ball report.

5.4.7.8 PALS Mode III Approach. Jet and turboprop aircraft shall pass through the 6-mile DME fix at 1,200 feet altitude, 150 knots, in the landing configuration and commence slowing to final approach speed. The 1,200-foot altitude will be maintained at approach speed until intercepting the glidepath

(approximately 3 miles, dependent upon glideslope angle utilized) unless otherwise directed.

Helicopters shall pass the 3-mile DME fix at 500 feet in a landing configuration and maintain 500 feet until interception of the glidepath or until otherwise directed.

The controller shall provide glideslope, azimuth, and range information. Pilots may use the 400 foot-per-mile rule to help schedule glideslope maintenance. The controller shall advise the pilot when at minimums unless the LSO has previously assumed responsibility. The pilot shall respond with a ball report.

Note

Lock-on must be maintained until touchdown during all PALS approaches to provide the LSO with essential course and glidepath information.

5.4.7.9 ICLS Approach. Jet and turboprop aircraft shall pass through the 6-mile DME fix at 1,200 feet altitude, 150 knots, in the landing configuration and commence slowing to final approach speed. ILM information shall be used to intercept and fly centerline and glideslope, and TACAN information shall be used for DME information until reaching ICLS minimum. ILM information may be used to achieve lineup early in the approach.

5.4.7.10 Nonprecision Approach. When **precision approach** radar or suitable visual landing aids are not available, aircraft on final approach will continue descent to 600 feet after passing the 6-mile DME fix. The final controller will provide sufficient information to the pilot for him to maintain an accurate azimuth and altitude until reaching nonprecision minimums.

Note

Per NATOPS Instrument Flight Manual (NAVAIR 00-80T-112) the pilot should establish a rate of descent which will ensure reaching the MDA at or before the missed approach point.

5.4.8 Missed Approach/Waveoff/Bolter. Jet and turboprop aircraft shall climb straight ahead on the extended final bearing to 1,200 feet altitude and wait for instructions from approach control.

Helicopters shall climb straight ahead on the extended final bearing to 300 feet altitude and await instructions from approach control.

All waveoff/bolter pattern turns shall be level.

If no instructions are received prior to reaching 4 miles or 2 minutes ahead of the ship, the pilot will attempt to make contact with the ship, giving identification and position. If instructions are not received, he will assume communication failure and execute a turn downwind reporting downwind abeam. If radio contact is not reestablished, he will proceed downwind and reenter as follows:

1. Fixed-wing aircraft commence turn to final at the 4 nm DME or 2 minutes past abeam position.
2. Helicopters reenter through the 3 nm DME fix or turn inbound 2 minutes past abeam.
3. PALS aircraft shall be alert for data-link displays.

5.4.9 Delta Procedures. In the event the deck becomes fouled or an excessive number of aircraft bolter or wave off, the CCA Officer shall issue via marshal control a signal Delta. The signal Delta shall be accompanied by the number of minutes of delay (even increments but never less than four) required to resume recovery operations (i.e., Delta 4, Delta 6, and so forth).

1. In marshal — Aircraft shall continue holding and await assignment of new EAT.
2. Commenced aircraft — Commenced aircraft above 7,000 feet shall level off at the next lower odd altitude and hold on the **inbound bearing** at a range in nm equal to holding altitude in thousands of feet plus base distance (angels + 15). The holding pattern shall be the same as the original marshal pattern. Aircrews shall report established in holding with new altitude and await assignment of new EAT. Aircraft at or below 7,000 feet will continue the approach.

Note

CV-2 aircraft that have descended from assigned marshal altitude shall return to overhead holding at the next lower odd altitude. CV-2 aircraft that have commenced

but have not vacated their last assigned marshal altitude shall return to overhead holding at that altitude.

3. Issuance of EATs — Marshal control shall issue new EATs as soon as possible. To preclude two aircraft having the same EAT, new EATs shall be issued from the latest to the earliest (i.e., top of the holding pattern to the bottom). Aircrews shall acknowledge receipt of the new EAT.
4. Lost communications — Aircraft in marshal shall commence approach at the last acknowledged EAT. Aircraft between marshal and 7,000 feet that have established Delta holding and subsequently realize lost communications prior to acknowledging new EAT shall commence approach immediately. All lost communication aircraft shall squawk appropriate Mode I (HEFOE) and III. Pilots shall take a 30° cut to the right to intercept a track 10° to the right of the inbound bearing and continue inbound to the ship.

WARNING

Be alert for possible aircraft in Delta holding at lower altitudes.

5.4.10 Night EMCON Recovery

5.4.10.1 All Aircraft Except Helicopters. This type of recovery shall be employed when operating under EMCON conditions and the ceiling and visibility are at least 3,000/5. Aircraft shall return to a prebriefed holding pattern and monitor marshal frequency. All aircraft will have lights on bright and steady with anticollision lights on. When ready to recover aircraft, the CV will turn on the lens and deck lights, flash the green cut light, and flash a white Aldis lamp. Aircraft will descend in accordance with air wing doctrine to not lower than 600 feet, which will be maintained until the ball is in sight. After the last jet is aboard, the tanker will be given a Charlie by a white Aldis lamp that he will acknowledge by turning off his anticollision light as he descends.

5.4.10.2 Helicopters. Helicopters approaching the carrier for landing shall enter starboard holding. The pattern will have to be flown visually by making

estimates on the 45° and the 110° relative bearings. Caution must be exercised not to drift aft of the 110° relative bearing. Altitude, airspeed, and spacing restrictions remain the same as night/VMC (at least 3,000/5). Upon entering the pattern, the helicopter will turn navigation lights to flashing bright. After the last fixed-wing aircraft has turned final or when given a green light or Charlie signal (see **Figure 3-2** of Aircraft Signals NATOPS Manual (NAVAIR 00-80T-113)), the helicopter leader shall accelerate to 90 knots and at the right-hand abeam position turn to intercept the optical glideslope at 1 mile and 400 feet. At the 45° position, the lead helicopter will receive a green light from the tower if cleared for the approach. When cleared, he will then turn his navigation lights to steady dim, leaving his tail position light on bright. If there is more than one helicopter airborne, they will all perform the same procedures as they pass through each checkpoint. If, when passing through the 45° position, a **red light** is received (Delta), then that helicopter and all following will wave off to the right, reentering starboard holding.

5.4.11 Communication or NAVAID Failure During Approach

5.4.11.1 Aircraft Alone. If navigational equipment is available, lone aircraft will continue approach. Pilot may utilize emergency survival radio on guard (243.0) frequency if time and safe control of aircraft permit. If all communication and navigational equipment is lost, the pilot will proceed as follows.

The pilot may elect to continue the approach by dead reckoning. Having made this decision, he will continue DR until at least 2 minutes past his expected ramp time, then climb on final bearing heading to VMC, squawk EMERGENCY, and conserve fuel. If below the overcast, the pilot may elect to fly a search pattern to locate the ship.

If the pilot elects to discontinue the approach, he will climb on final bearing heading to VMC and expeditiously join up on the tanker or other available aircraft and conserve fuel. Depending upon weather at the divert field and fuel state, the pilot may elect to proceed directly to the divert field after having climbed out on the final bearing heading.

Helicopters may continue descent to 300 feet, proceed by DR until 2 minutes past individual expected

ramp time, and then fly the appropriate triangular pattern for lost communications, squawk EMERGENCY, and conserve fuel.

PALS-equipped aircraft shall be alert for data-link displays. Mode II information shall be transmitted to suitably equipped aircraft.

Aircraft equipped with an operating ARA-63/ARN-138 should conform to the NATOPS lost communication procedures utilizing the ARA-63/ARN-138 and TACAN during the recovery phase to intercept the final approach course and glideslope. Under conditions of intermittent or erroneous TACAN azimuth information, a 12-nm arc should be flown at an altitude of 3,000 feet. Final bearing will be indicated by the centering of the ARA-63/ARN-138 azimuth needle. When approach to the final bearing is indicated, an immediate turn and landing transition should be completed in the expected direction of the final approach course determined during the arc. Azimuth tracking on the inbound ARA-63/ARN-138 radial to the glideslope (approximately 8 nm) and constant glideslope to ball acquisition can be flown.

WARNING

Extreme care shall be exercised by controllers and pilots using the above procedure. The controller must ensure positive aircraft identification prior to lock-on. The pilot shall cross-check his approach with other available instruments (DME, altimeter, etc.).

Note

- The glideslope information of the ARA-63/ARN-138 should not be used until within 20° of the final bearing because geometric effects of the planar SPN-41 elevation antenna cause erroneous elevation indications.
- An initial turn in the wrong direction upon intercept of the ARA-63/ARN-138 final bearing will result in the glideslope indication continuing to climb and inverse azimuth tracking.

5.4.11.2 Aircraft in Company. An aircraft with navigation and/or communication equipment inoperative in the company of an escort aircraft with navigation and communication equipment in working order will be handled as a single aircraft in the recovery procedure. The escort aircraft becomes the flight leader and will visually communicate with the distressed aircraft in accordance with standard aircraft NATOPS procedures. The distressed aircraft will assume a position on the starboard wing of the lead aircraft. Transition to landing configuration should be made clear of clouds either above or below the overcast as desired. The controller shall be advised when this transition does/will occur, when the lead aircraft has the OLS in sight, he will visually communicate a lead change and break off to the left. The distressed aircraft will continue a visual approach to landing. The escort aircraft will parallel the final bearing course and maintain a position so as to be easily acquired and be rejoined by the distressed aircraft in the event of a bolter or waveoff. Unless otherwise directed, the escort aircraft will repeat the above procedures until the distressed aircraft is recovered and then continue normal procedures for his own recovery. The SPN-42/46 radar should be locked onto the lead aircraft. The PALS final controller should instruct lead aircraft “beacon on,” wingman “beacon off,” and then select “beacon lock only” on the SPN-42/SPN-46 console.

WARNING

If the address of the escorted aircraft is inserted in the PALS, the escorted aircraft will receive needle information. When the lead aircraft breaks away on OLS acquisition, this may give the escorted aircraft an erroneous “fly down, fly right” presentation on the needles. The displayed error may become progressively larger as both aircraft close on the ship regardless of the approach actually being flown by the escorted aircraft.

5.4.11.3 Failure of Carrier Navigation Aids/CATCC Radars Prior to Approach. Individual ships should develop special procedures to recover airborne aircraft in the event of a casualty to shipboard air traffic control equipment. Selection of

special/alternate approach procedures will be dictated by the availability of suitable navigational equipment aboard escort ships and/or embarked aircraft. Should the use of assist ship navigation equipment or utilization of airborne radar and control become necessary, approach minimums, separation between aircraft, and size of the recovery will be adjusted so as to ensure safety of recovery operations.

5.4.12 Radar Handoff Procedures. Positive radar identification shall be accomplished by the receiving agency prior to transfer of control. Control will be transferred only after the receiving agency has notified the transferring agency that positive radar contact has been established.

5.4.13 Voice Communication Procedures.

5.4.13.1 Compulsory Arrival, Marshal, and Approach Voice Reports.

1. Entrance into carrier control area — Information required from flight leader (see [paragraph 5.1](#))
2. Receipt of:
 - a. Marshal instructions
 - b. Type recovery
 - c. EAT or Charlie time
 - d. Altimeter setting
3. Entering holding/marshal with altitude, fuel state, and hung/unexpended ordnance (if any)
4. Altitude changes
5. Commencing approach, with fuel state, altimeter setting
6. Frequency changes
7. Platform (jet/turboprop aircraft)
8. Ten miles (jet/turboprop aircraft)
9. “Coupled/needles” as appropriate and “command control” if Mode I/IA approach
10. Three miles (helicopters)
11. Breaking away (section approaches only)

12. Ball call report — (side number, aircraft type, ball or **Clara/Clara lineup**, fuel state, hung/unexpended ordnance, coupled/uncoupling (if applicable), automatic/manual)
13. Waving off
14. Abeam, with fuel state after bolter/waveoff.

5.4.13.2 Phraseology. Standard ATC and precision instrument approach phraseology shall be used with the following exceptions:

1. Fuel state reports (thousands of pounds; for example, “3.5”)
2. Altitude (angels; for example, “1.2”)
3. Heading changes on Case III final approach after lock-on or final radar contact (normally soft headings; for example, “301, right five”).

5.5 RECOVERING FIXED-WING AIRCRAFT

5.5.1 Preparation for Recovery. Preoperational checks of the arresting gear, optical landing aids, and associated equipment are ordinarily completed before the beginning of **air operations**; therefore, preparation for recovery generally consists of nothing more than manning the necessary stations. Whenever fixed-wing aircraft are airborne, all arresting gear equipment shall be maintained in a ready status unless the commanding officer has granted permission to place specific items of equipment out of commission for maintenance or other reasons.

Fifteen minutes before each scheduled recovery or immediately upon hearing the word passed to prepare to recover aircraft, personnel will man stations and take the following preparatory actions.

The air officer shall perform the following:

1. Confirm the recovery time with CATCC and the bridge.
2. Obtain the expected BRC.
3. Provide CATCC the **break time** for Case II recoveries or ramp time for Case III recoveries.

4. Monitor/update fuel status of returning aircraft, information on hung or unexpended ordnance, aircraft emergencies, if any, and the current altimeter setting.
5. Confirm with the bridge that the fantail and adjacent sponson(s) are secured during recovery of fixed-wing aircraft.

The ILARTS and PALS radar operators shall ensure equipment is turned on and operating.

The PriFly lens operator shall receive permission from the air officer prior to turning on lens.

The recovery equipment controller in PriFly shall perform the following:

1. Ensure all arresting gear engines, the arresting gear deck-edge station, ILARTS room, and lens room are manned and ready to recover aircraft.
2. Report to the air officer when all stations are manned, giving the existing arresting gear engine and lens settings.

The arresting gear officer shall perform the following:

1. Inspect the landing area for loose gear.
2. Ensure all after deck-edge antennas are positioned as required.
3. Check the condition of crossdeck pendants, barrel fittings and wire supports, and ensure retractable sheaves are in the raised position.
4. Ensure all aircraft and mobile equipment parked on the flight deck are inside the safe-parking line.
5. Ensure hook runners and the deck-edge operator are on station.
6. Ensure the ready barricade, including deck ramps, is in a ready status, with a clear route to the area and a tractor with driver is standing by.
7. Ensure waist catapult slot buttons are installed in accordance with current bulletins and ensure the deck status light is operating.
8. Notify PriFly when the deck is ready.

The flight deck officer shall perform the following:

1. Ensure the mobile crane, a forklift, and a tractor are warmed up and that drivers are standing by. Also ensure operationally ready mobile firefighting equipment is manned and that all have clear access to the flight deck.
2. Ensure the crash crew is on station and that directors and plane handlers in sufficient number are standing by.
3. Ensure the flight deck area is clear of all unnecessary personnel.
4. Ensure the flight deck is clear of unnecessary equipment and that all deck hatches in the landing area are closed and properly secured prior to signaling a ready deck forward.

The LSO shall perform the following:

1. Conduct a two-way radio check and sound-powered phone checks on appropriate circuits.
2. Check the landing area lights and lens for proper brilliance when turned on and check the cut and waveoff lights for proper operation.
3. Ensure the following distress equipment is available at the LSO platform:
 - a. Battery-powered marker
 - b. Life preserver ring
 - c. Very pistol
 - d. Search and rescue sonobuoy
 - e. Aldis lamp (night operations only).

The catapult officer shall ensure the following:

1. Catapult shuttles are properly positioned and shuttle cover installed on catapult 3.
2. Track slot seals are in place on bow catapults (except during CARQUALs).
3. Catapult deck gear is clear of landing area.
4. For ships so equipped, waist ICCS is fully lowered.

The weapons officer shall ensure the following:

1. An EOD representative shall be stationed in flight deck control during all operations when aircraft are carrying weapons. Unless assistance is required, EOD personnel should not normally be exposed to the flight deck during launches or recoveries.
2. The EOD officer, Air Gunner, and air wing weapons officer are equipped with an SRC-22 (or equivalent) communication set during launch and recovery operations.

5.5.2 Approach and Landing. For detailed fixwing recovery operations and procedures: Refer to CV Flight/Hangar Deck Natops 00-80T120.

5.5.3 Special Safety Precautions. Observe the following safety precautions.

1. While aircraft are being recovered, no personnel other than those required by this instruction shall be in the catwalks, on the flight deck, or in the arresting gear engine rooms or ILARTS/lens room without the express permission of the air officer.
2. The deck will be considered foul any time unauthorized personnel are in or around aircraft parked adjacent to the landing area.
3. Personnel shall not stand in or otherwise block entrances to the island structure or exits leading off the catwalks.
4. Personnel shall not sit on missile equipment, chocks, deck-edge coaming, or any other object during flight quarters or while aircraft is turning on the flight deck. Personnel should not turn their backs on aircraft landing or taxiing out of the gear.
5. In taxiing aircraft out of the gear, directors must be aware of the activities of the hook runner, tillerbar man, and wing riders.
6. All taxi signals shall be answered promptly and accurately unless the pilot considers that a dangerous situation exists or is developing, in which case he shall *stop* immediately.
7. If a pilot loses sight of his director, he shall *stop* immediately. The director shall exercise care to remain in plain view of the pilot at all times.

8. No director shall give signals to a pilot who is being controlled by another director except in an attempt to avert an accident.
9. Personnel having reason to suspect the readiness or condition of any arresting gear engine, crossdeck pendant, or associated equipment shall immediately cause the deck to be fouled by informing the arresting gear officer, deck-edge operator, and the recovery equipment controller in PriFly.

WARNING

If the arresting gear crew is required to enter the landing area during aircraft recovery, a safety man shall be stationed forward of that crew, facing aft, to ensure arresting gear crew safety from approaching aircraft.

10. If during recovery operations any part of the aircraft affecting safe recovery strikes the ramp, aircraft, or other equipment on deck or ship's structure other than normal flight deck protrusions (crossdeck pendants, flight deck light covers, ILARTS heads, or waist catapult ramps) and the aircraft subsequently bolters, no further effort shall be made to effect a normal carrier arrestment.
11. PALS radar beacon-equipped aircraft parked or taxiing aft of the island shall have the beacon switch in off or standby position during recovery operations. Aircraft preparing for launch shall delay PALS beacon self-test until forward of the island or airborne.
12. Pyrotechnic devices shall not be used in marking aircraft accident sites to preclude igniting aviation fuel.

To minimize the possibility of an aircraft landing on a foul deck, the following procedures are mandatory.

1. The lens (and at night, the landing area lights) shall never be turned on without the express permission of the air officer.
2. Except for the purpose of conducting tests, neither the lens nor the landing area lights shall be turned

on until the controlling LSO establishes positive communications with the air officer.

3. The waveoff lights shall be continuously activated anytime the lens or landing area lights are turned on and the LSO is not on the platform.
4. Aircraft shall be permitted to conduct practice CCA approaches, including PALS approaches. When the OLS is on and deck lights (night only) are on, PriFly and the LSO platform shall be manned by qualified personnel. Both stations will have communications with the aircraft; assigned minimums shall be no lower than 200 feet and one-half mile. With OLS and deck lights (night only) off, the LSO platform need not be manned. CCA shall not assign minimums lower than 500 feet and 1 mile. In all cases, CCA will issue, "This is a practice approach to a low approach only. Upon reaching (minimums), execute waveoff."
5. To avoid unnecessary delay in recovering the first aircraft, the lens and/or landing area lights may sometimes be turned on a short time before the ship is completely ready to commence recoveries. When this is done, the LSO shall wave off approaching aircraft at a distance of one-half mile or greater if he has not received the "clear deck" signal.
6. During instrument recoveries, PriFly will keep CATCC advised as to the status of the deck and provide the estimated time the deck will be clear. CATCC shall keep PriFly advised as to the type and position of the nearest aircraft.
7. Combat and CATCC must keep PriFly informed of any aircraft known or suspected to have radio failure.
8. After calling "ball," if no verbal/visual acknowledgment of positive control by the LSO is received, the pilot shall execute his own waveoff early enough to clear the landing area by 100 feet above flight deck level.

The deck is foul when any of the following conditions exist:

1. The red rotating beacon is on.
2. Personnel, aircraft, support equipment, or loose gear are in the landing area.

SEE IC # 11

3. Arresting gear engines are not properly set and in battery.
4. There is a known or suspected malfunction of recovery equipment.
5. After each touch and go, arrestment, bolter, or waveoff.

Note

During night operations when the deck is open, but momentarily foul, the landing deck lights will remain on and foul deck waveoff will be controlled by the LSO.

During night operations, green wands shall be used only by those air department personnel authorized to launch aircraft or signal a clear deck.

5.5.4 Control of the Landing Pattern (VMC).

The air officer is charged with the overall control of the VMC landing pattern (Figure 5-6) and is assisted by the LSO. Specific responsibilities are assigned as follows.

5.5.4.1 Air Officer

1. Provide pilot with sufficient information to ensure that aircraft are established in the landing pattern in time to meet the expected Charlie time.
2. Assign or revise the landing order as necessary.
3. Regulate the number of aircraft in the landing pattern to ensure a steady flow of traffic while preventing the pattern from becoming extended or overcrowded.
4. Monitor the landing interval.
5. Whenever possible, maintain visual contact with all aircraft in the Delta and Charlie pattern.
6. Maintain an accurate count of the number of aircraft to be recovered, and inform the bridge when only two remain.
7. Monitor the upwind pattern, being particularly alert to warn pilots of aircraft boltering or waving off of their proximity to aircraft launching or breaking.
8. Maintain visual contact with aircraft that have radio failure and instruct the LSO with regard to visual signals to be given.

9. Inform the LSO of any unusual condition(s) affecting the normal recovery of aircraft.

5.5.4.2 LSO (Under the Supervision of the Air Officer)

1. Control all fixed-wing aircraft approaches after the 180° position.
2. Ensure that approaching aircraft are properly configured.
3. Monitor the operation of the OLS and crosscheck the approach radar/ICLS glidepath angle.
4. Instruct and supervise the LSO talker and hook spotter.
5. Assist in controlling aircraft that have radio failure by flashing the cut or waveoff lights in accordance with signals delineated in Figure 5-11.
6. Whenever possible, maintain visual contact with all aircraft in the Charlie pattern.
7. Inform the air officer of any unusual conditions affecting the safe recovery of aircraft.

5.6 RECOVERING HELICOPTERS

5.6.1 Recovery Procedures. Normally, helicopters will be recovered after all fixed-wing aircraft. Helicopters recovering after night plane guard duties should be provided positioning information by CATCC in order to expeditiously intercept the glideslope and effect a landing following recovery of the last fixed-wing aircraft. When a flight of helicopters is being recovered under VMC, the leader of the flight should plan to be at the ramp within a minimum safe interval after the last fixed-wing aircraft has landed. The helicopter which is the farthest advanced on the inbound radial and has not turned to parallel the ship's course will be considered No. 1 in the landing pattern and should expeditiously effect a landing following recovery of the last fixed-wing aircraft. The helicopter cleared No. 1 to land should be assigned a landing spot farthest forward into the wind. Subsequent helicopters should be cleared to land in sequence behind the No. 1 helicopter. In the event the last fixed-wing aircraft waves off, all helicopters will return to the Delta pattern (see Figure 5-6). Prior to issuing landing clearance, the air officer shall ensure the helicopter may land within

the relative wind envelope prescribed in the respective aircraft NATOPS flight manual, and the tower shall transmit relative wind direction, speed, and landing spot(s). For landings not oriented to the angle or axial centerline (day VMC only), the air officer will ensure an adequate waveoff path is available to the helicopter.

WARNING

Because of the severe rotorwash and wing-tip vortices produced by CH-53E and MH-53E helicopters, land/launch operations should not be conducted upwind of other aircraft or any unsecured area. Because of this severe hazard, consideration should be given to conducting CH-53E and MH-53E operations from after-deck spots only.

Note

- Rotating beacon light signals for helicopter operations are located in Figure 3-1 of the Aircraft Signals NATOPS Manual (NAVAIR 00-80T-113).
- Army helicopters are not equipped with an automatic blade fold/spread system.

Time for manually folding and spreading main rotor blades should be taken into account for tactical planning during shipboard operations.

- Certain Army and Air Force helicopters are not equipped with a rotor brake. Extended rotor coast down times can be expected. These times can vary with relative wind speed and direction, and can exceed 8 minutes in winds as light as 20 knots. The ship shall be ready to provide optimum winds for the windmilling stop of the rotor system.

During Case III recoveries, the approach shall be flown as directed by CATCC until the pilot acquires visual contact with the optical landing aids, at which time the pilot shall “call the ball.” Control will then be assumed by the air officer, who shall issue final landing clearance. In the event of a waveoff, the pilot shall parallel the final bearing course and report to CATCC for control. At night, navigation lights shall be steady bright and anticollision lights on until established on the final bearing, at which time the position lights shall be placed on dim and steady.

The forward anticollision light shall be turned off when the meatball is in sight.

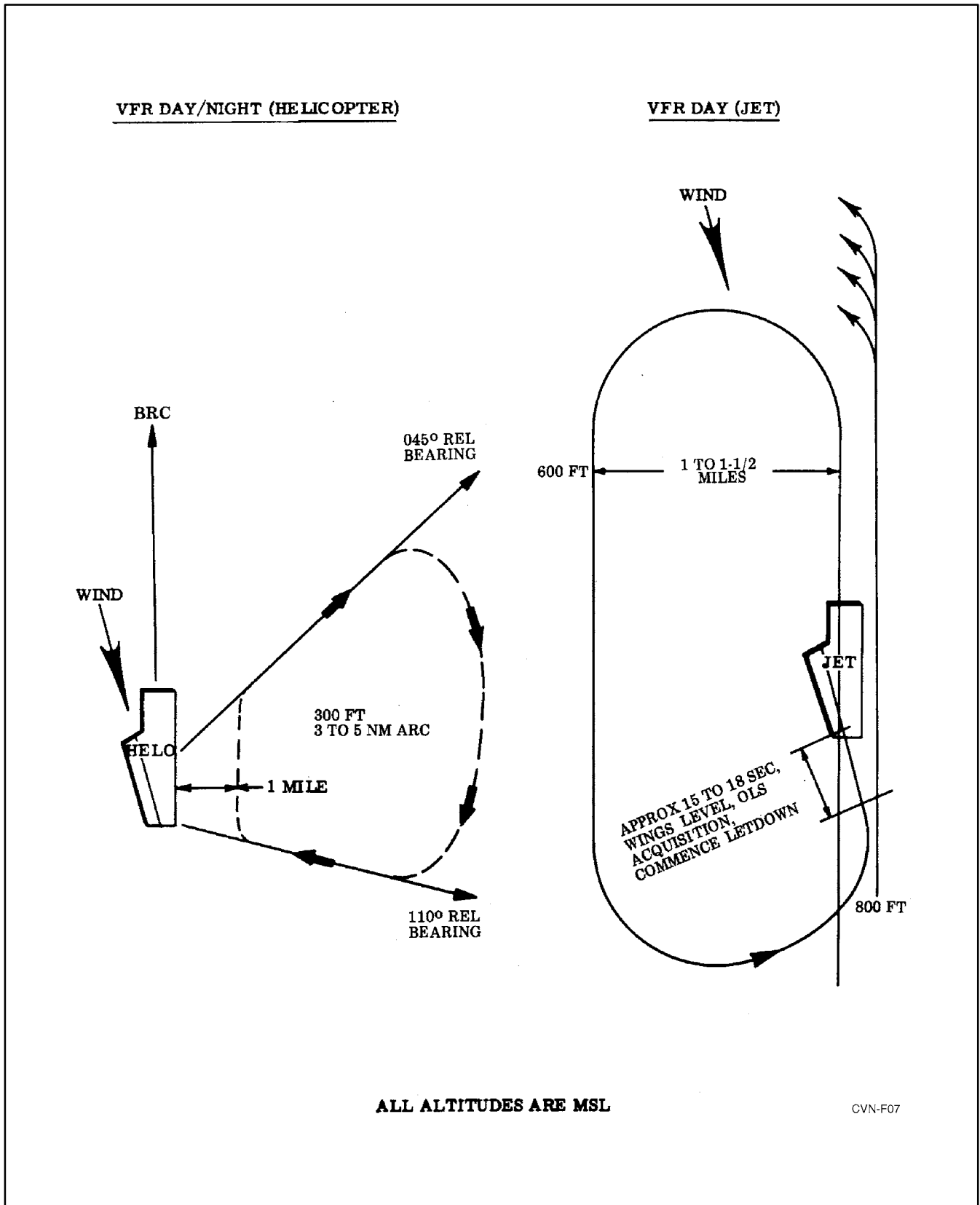

Figure 5-6. Carrier Landing and Patterns and Approaches

When the word is passed to stand by to land helicopters, the LSE shall take a position clearly visible to the pilot. The tower will obtain a “gear down” report from the pilot before issuing final landing clearance. As the helicopter approaches, the LSE shall ensure the landing gear is down, the rotating beacon that controls his area of the flight deck is green or amber, as appropriate, and that the landing area is clear of personnel, equipment, and loose gear.

Except in unusual circumstances, helicopters shall be landed only on marked spots visible to the pilot during the final approach.

Except for the “waveoff” and “hold” signals, the LSE signals will be accepted as advisory and the pilot has full responsibility for the proper and safe operation of the aircraft. At night when two or more helicopters are landing, the navigation light shall remain STEADY/DIM and the tail anticollision light shall remain ON until touchdown. After landing and before disengagement, chocks will be placed on the main wheels and the initial aircraft tiedowns will be attached by the deck crew. A hold signal will be given by the LSE while tiedowns are being attached to indicate that an unsafe takeoff condition exists. Navigation lights shall be switched to FLASHING DIM (day: FLASHING BRIGHT) until the rotors have been disengaged and are fully stopped. The LSE will then signal for the aircraft lights to be turned OFF. When helicopters are recovered immediately ahead of fixed-wing aircraft, pilots shall shut down and disengage as expeditiously as feasible. They shall remain in their aircraft until towed clear of the fixed-wing landing area. An amber or red light will be ON whenever rotors are engaged on deck.

5.6.2 NVG Equipment Aided Approaches.

Crews aided with NVGs may make a visual approach to a spot rather than a Carrier Controlled Approach (CCA) provided they prebrief such an approach, are not IMC, and have sufficient illumination/visibility.

Night Vision Goggle (NVG) Centerline Visual Approach. During VMC and using NVGs, the HAC may accept a visual approach to the fantail and proceed along the centerline for landing on spot 3, 4, or 5. After the last fixed wing aircraft on final is identified by the

Air Boss/CATCC, the helicopter will take interval and land visually.

Night Vision Goggle (NVG) Slide-in Visual Approach. At the HAC’s discretion, the helicopter may slide in to a landing Spot 3, 4, or 5 from the port side of the ship. Visual contact with the ship and NVG usage is required.

5.6.3 Recommended Deck Lighting Configuration for Helicopter NVG Aided Takeoff and Landing.

Blue Deck Lights	ON
Overhead Sodium Oxide (SOX) Light	ON
Beacon Lights	ON
PLAT IR Flood	OFF
Red Deck Status Lights	OFF
Centerline Lights	OFF
Landing Area Lights	OFF
Drop Lights	OFF
IFLOLS/MOVLAS	OFF

Note

SOX lights cause minimal NVD blooming and negate the need for a qualified NVD-LSE while providing ample lighting for flight deck crews.

5.6.4 Special Safety Precautions. The following precautions shall be observed when recovering helicopters.

1. Except in case of emergency, pilots shall not stop engines or fold rotor blades without proper clearance from the LSE.
2. Helicopters should not be recovered while the ship is in a turn.
3. Personnel required to be in the area of helicopters disengaging rotors shall stand next to the fuselage or well outside the rotor arc.
4. A helicopter shall not be flown over another aircraft when landing.



The combination of relative winds and rotor downwash when launching or landing a helicopter immediately adjacent to a spot occupied by a helicopter engaging/disengaging rotors, or occupied by a shutdown helicopter not folded or secured by rotor blade tiedowns, may cause rotor system damage to the engaging/disengaging or shutdown helicopter.

5. Helicopters shall never be towed or pushed while rotors are engaged.
6. The waveoff and hold signals are mandatory and shall be executed immediately.
7. Case III helicopter recoveries shall be conducted to the angled deck, from astern, utilizing the OLS, with the wind oriented to the centerline of the angle deck, and within the parameters set forth in the respective aircraft NATOPS flight manual. During night VMC recoveries on CVs equipped with operating white floodlights and when the after portion of the flight deck is not clear, helicopters may make an approach utilizing the OLS and centerline of the angle deck. Upon approaching the fantail and when the deck and LSE have been visually acquired, the helicopter shall then slide over, fly up the port side to the landing spot, and slide into a landing.
8. Helicopters shall not cross within 5 miles of a ship's bow and within 3 miles of a ship's stern without specific approval of the air officer. A vertical replenishment helicopter may request and be granted continuous use of an established flightpath.
9. The air officer or his representative shall pass over the 5 MC, "Stand well clear of helo number — while engaging/disengaging rotors."

Inboard mounted external fuel tanks or stores on Army UH-60 Aircraft significantly impede access to the main wheels, exposing flight deck personnel to risk of injury in the event of inadvertent jettison or aircraft movement while chocking. Consideration should be given to safing the external stores jettison circuit prior to chocking, balanced with the need to expeditiously chock and chain the aircraft to prevent aircraft movement under severe deck motion conditions.

5.7 SPECIAL PROCEDURES FOR CARRIER QUALIFICATION LANDING

5.7.1 Fixed-Wing Aircraft. The number of aircraft in the landing pattern shall be limited to six.

Maintaining a proper and uniform interval is very important in the CARQUAL pattern. The air operations officer and the air officer shall make appropriate recommendations. Jet/turboprop aircraft night CARQUALs shall be under CCA control. [Advisory control](#) may be specified by the ship's commanding officer when weather permits.

- The air officer must be acutely aware of the responsibility to ensure the initial separation between bolter/waveoff and departing aircraft during CARQUAL and cat-trap-cat evolutions.
- CATCC's restricted radar coverage (blindspot) ahead of the ship requires aircrew to exercise good lookout doctrine and radio discipline upon departure.

During night CARQUALs, CCA shall utilize a single frequency to control all aircraft in the CARQUAL pattern.

Anytime CARQUAL or refresher landings are being conducted, a senior representative of each squadron involved should be present in the tower. During IMC and night operations, his station will be in air operations. He must be well qualified in the aircraft and prepared to advise the air officer in the event of an emergency.

It is the responsibility of the air operations officer to keep the air officer accurately apprised of the number of landings required for each aircraft. Air operations/CATCC will maintain a status board that will show landings required, landings completed, and location of each aircraft (in Delta, in the Charlie pattern, or on the deck).

The air operations officer is responsible for providing the air officer with accurate bingo/divert data. Before commencing and/or during CARQUALs, he shall compute the distance and bearing to the bingo/divert field and the fuel required for the model aircraft involved. Bingo/divert data will be broadcast on the recovery frequency by PriFly or CCA as appropriate.

The decision to divert aircraft will be made by the commanding officer or his designated representative. The air operations officer and the air officer shall make appropriate recommendations during IMC/night and VMC operations, respectively. In addition, the LSO will make timely divert recommendations to the air officer based on unsatisfactory pilot performance or unsatisfactory CARQUAL conditions around the ship. It is the pilot's responsibility to inform the tower if he reaches bingo fuel state and has not been ordered to divert.

Changing pilots when an aircraft is on the flight deck with engine(s) running is an inherently dangerous practice requiring extreme care. When a change is made, the aircraft shall be chocked and have at least the initial tiedowns attached. Pilots shall not leave/switch their seats until given the "tiedowns in place" signal by the aircraft director.

Note

It is the pilot's responsibility to inform the tower when reaching holddown fuel state after trapping and the aircraft has not been taxied to a refueling spot.

5.7.2 Helicopters. When feasible, two landing spots will be utilized for CARQUAL landings. The pattern shall be a left-hand racetrack on the port side of the ship. Pattern spacing shall be adjusted to permit one aircraft to be launched prior to another being landed. When the pilot acquires the meatball, he shall report his side number, "ball," and "gear down."

Night CARQUALs shall be under CCA control. Advisory control may be specified by the ship's commanding officer when weather permits.

The pilot in the right seat shall be in control of the aircraft unless the tower is informed to the contrary. When changing pilots, the aircraft will be chocked and have initial tiedowns attached.

5.8 EMERGENCY LANDING

5.8.1 Fixed-Wing Aircraft. At first indication of a possible emergency landing, the air officer will pass the word "stand by to make a ready deck." At this time, arresting gear and Crash Salvage personnel, ILARTS, and lens operators will immediately man their stations. It is the responsibility of PriFly to contact the LSO, who will proceed to the platform. The squadron duty officer will be notified. Tractors will be attached to all aircraft parked in the landing area, tiedowns will be removed when directed by the plane directors, and directors and chock men will stand by. A helicopter should be manned and started unless an airborne helicopter is available for plane guard. If the emergency condition requires a straight-in approach or a straight-in approach is contemplated, the SPN-41 shall immediately be activated without pilot request.

When it has been determined that an emergency landing will be made, the Air Officer will pass the word, "Make a ready deck," at which time the landing area will be cleared as expeditiously as safety permits. Personnel concerned will stand by to rig the barricade if called for. The air officer shall pass an expected Charlie time to the distressed aircraft.

Pilots of aircraft returning to the ship for an emergency landing shall not shift from the control frequency to tower frequency until directed to do so unless radio contact has been lost on the control frequency. Normally, the tower and LSO will shift to the control frequency, thereby avoiding the necessity of a frequency change by the pilot. In no case will the pilot of an aircraft in distress leave an assigned frequency

without broadcasting the frequency to which he is shifting.

As the ship is being prepared for the landing of aircraft, the air officer will pass as much pertinent information as possible to the flight deck, bridge, LSO, and CATCC. The air officer shall determine the amount and type of firefighting equipment to be broken out and direct the deployment of personnel, depending upon the nature and seriousness of the emergency.

5.8.2 Helicopters. As much deck space as possible will be made available for emergency helicopter landings. If time permits, the senior helicopter squadron or unit officer on board should take station in the tower or in CATCC, and the air officer should determine the optimum relative wind and request the bridge to maneuver the ship as necessary. In clearing a helicopter for an emergency landing, PriFly will ordinarily designate an area of the flight deck rather than a specific landing spot. Once the aircraft is on final approach, it is imperative that the ship hold a steady course.

During an emergency landing, the LSE, if immediately available, shall stand at the upwind edge of the designated landing area. The LSE signals are advisory in nature, except for the waveoff and hold signals, which are mandatory. The LSE shall give a waveoff only in case of a foul deck or if instructed by the tower to do so.

5.9 EMERGENCY SIGNALS

5.9.1 Visual Signals to Ship From Aircraft With Radio Failure. Figures 5-7 and 5-8 provide visual signals to be used in the event of radio failure. Aircraft configuration is the primary daytime indicator of the pilot's desires or intentions. At night, aircraft lighting configuration is the primary indicator of the pilot's desires or intentions.

5.9.2 Visual Signals to Aircraft From Ship Under EMCON or Lost Communication Conditions. Figure 5-9 provides visual signals for giving commands or advisories to aircraft when the ship has lost its communication capability or is under EMCON conditions.

5.9.3 Carrier Pattern Emergencies. The LSO will make appropriate recommendations to the air officer or pilot as indicated in Figure 5-10.

5.9.4 Day Communication Emergencies. Figure 5-11 describes appropriate action for day communication emergencies.

5.9.5 Night Communication Emergencies. Figure 5-12 describes appropriate action for night communication emergencies.

5.10 TANKER OPERATIONS

Tankers assigned duties in support of the recovery of aircraft shall use the following procedures:

1. Only those tankers that have a known good store and sufficient fuel to meet receiver fuel requirements shall display the flashing green light.
2. For optimum utilization of tankers, single-cycle operation is recommended.
3. A specific existing agency (i.e., [departure control](#)) shall be designated tanker control with the responsibility to monitor:
 - a. Tanker give-away fuel status
 - b. Tanker location
 - c. Location and fuel requirements of the low state aircraft
 - d. Coordination of the tanker and receiver rendezvous.

5.10.1 Recovery Tanker Procedures

5.10.1.1 CASE I/II. After launch, the oncoming recovery tanker shall switch to departure control for assignment. All tanker packages should be checked as soon as possible after launch. When it has been determined that the new tanker store is operational, departure control should be advised immediately. The recovery tanker shall maintain a rendezvous circle oriented on the CV (Figure 5-13). The rendezvous circle shall contain four reference points. Minimum pattern altitude shall be 1,500 feet. This pattern is a left-hand circle within 5 nm of the CV during launch and recovery operations. When the last jet is aboard, the tanker shall climb to prebriefed altitude and switch to assigned frequency for control.

5.10.1.2 Case III. The recovery tanker pattern shall be assigned by departure control. It shall be at least

1,000 feet above the overcast or VMC between layers, but not less than 2,500 feet MSL. The tanker pilot shall advise departure control of the best altitude and position to conduct emergency tanking. Positive control shall be provided for tanker overcast penetrations. Departure control shall assist in positioning the tanker near a potential receiver and shall keep the tanker informed of the potential receiver's position.

Note

Tanking shall not be attempted below 1,500 feet during Case I/II and 2,500 feet during Case III.

5.10.2 Rendezvous Procedures.

5.10.2.1 Rendezvous Low (Day and Night). When directed to "hawk" (closely monitor) a particular aircraft that is a potential receiver, the tanker pilot shall position the tanker to be at the 2-o'clock position of the low-state aircraft as it bolters or waves off. The minimum altitude for rendezvous shall be 1,500 feet day, 2,500 feet night. When directed, the tanker shall switch to the potential receiver aircraft's frequency. If visual contact is not acquired, the controlling agency shall provide assistance until visual contact is established. The receiver should generally make the final rendezvous on the tanker. Positive radio communications must be established if the tanker will be rendezvousing on the receiver at night. The tanker should stream the drogue as the receiver joins, thus expediting plug-in. The tanker pilot shall report to tanker control the following:

1. When the receiver is taking on fuel
2. When refueling has been completed, the amount of fuel transferred, and update give-away.

5.10.2.2 Rendezvous High/On Top (Day and Night). Departure control shall provide positive control until visual contact is established. The receiver shall make the final rendezvous on the tanker and report as previously described.

5.10.3 Recovery Tanking Pattern. After the receiver is engaged, the tanker aircraft shall establish a

racetrack pattern in the vicinity of the ship. Unless special circumstances exist, the tanker should not proceed more than 10 miles ahead of the ship. The downwind leg should be 3 to 5 miles abeam and tanking should be completed prior to reaching a point 6 miles astern to allow for proper pattern entry. If tanking is done above an overcast, departure control may direct adjustment of the pattern so as to allow for normal descent and CCA pickup.

5.10.4 Recovery (Case III). The desire to expedite tanker recovery must not jeopardize flight safety. The recovery tanker shall be given positive control unless executing an instrument approach procedure published in this section or operating under night EMCON conditions. The aircraft shall be level during the turn to final bearing and given sufficient clearance to pass through 6 miles at 1,200 feet.

Note

If recovery tanker is established 1,200 feet abeam, the six mile gate is not required.

5.10.5 Fuel Transfer and Dump Control. Each ship/air wing shall promulgate supplementary instructions that shall include the following instructions.

1. Bingo data for all embarked aircraft
2. Low state figures (i.e., state at which aircraft will normally be ordered to tank) and amount of fuel to be transferred to each type aircraft when no divert field is available
3. Procedures for control of tanker fuel by CATCC
4. Minimum fuel for barricade engagement.

Except in an emergency, tankers shall obtain clearance from departure control before transferring or dumping fuel. Departure control shall be advised of any changes of tanker fuel state and give-away as appropriate.

If the tanker refueling hose cannot be retracted, the hose shall be guillotined prior to recovery. If the hose fails to separate, the aircraft shall be diverted to a suitable landing field. When the situation prevents an aircraft divert and it is equipped with an external

PILOT'S DESIRES OR INTENTIONS	VISUAL SIGNAL
<ol style="list-style-type: none"> 1. I desire immediate landing. 2. I desire to land but can wait for the next recovery. 3. I am proceeding to the bingo field. 	<p>Fly up the port side of the ship, low and close aboard, rocking wings, in a landing configuration with hook down. Navigation lights bright and steady with anticollision light on. If turning final in VFR pattern or approaching final on a CCA, momentarily turn on the taxi light, if available.</p> <p>Fly up the port side with the landing gear up, hook down, navigation lights bright and steady, and anticollision light off while abeam the ship.</p> <p>Fly up the port side of the ship, rocking wings, with landing gear and hook up, navigation lights bright and steady, and anticollision light on. If fuel state and nature of the emergency permit, continue making passes until joined by a wingman. Upon reaching bingo fuel state, proceed alone, setting IFF/SIF to emergency when departing.</p>
<p>Note</p> <ol style="list-style-type: none"> 1. The requirement for gear down and rocking wings as the signal for an immediate landing is not required when considered unsafe by the pilot due to the nature of the emergency; for example, loss of an engine in multiengine aircraft. 2. At night, aircraft flying close aboard the port side of the ship without lights are considered to have an emergency requiring immediate landing. 	

Figure 5-7. Emergency Signals to Ship From Fixed-Wing Aircraft With Radio Failure

PILOT'S DESIRES OR INTENTIONS	VISUAL SIGNAL
<ol style="list-style-type: none"> 1. I require immediate landing. 2. I desire to land but can wait for the next recovery. 	<p>Fly close aboard starboard quarter, remaining clear of other traffic, with gear down and floodlights/landing light on. With complete electrical failure, fire a red flare to seaward.</p> <p>Fly by or hover on the starboard side of the ship, low and close aboard, with navigation lights bright and flashing and anticollision light on.</p>

Figure 5-8. Emergency Signals to Ship From Helicopters With Radio Failure

refueling store, the store shall be jettisoned prior to attempting a carrier landing. If the hose cannot be guillotined and/or the refueling store jettisoned, normal arrested landing procedures shall be utilized.

WARNING

- Shipboard recovery of a tanker aircraft with an extended hose presents a missile hazard that may be caused by shattering of the drogue/basket as it strikes the ramp area. Prior to recovery, the flight deck should be cleared of all but required recovery personnel. Only the controlling LSO should remain on the platform, and he should utilize the safety net as the aircraft crosses the ramp. If possible, aircraft adjacent to the landing area should be respotted forward or struck below to the hangar deck.
- Even though the probability of damage to the aircraft by drogue/basket slap during a bolter is slight, the pilot should be aware of this possibility.

5.11 DIVERSION OF AIRCRAFT

The air operations officer or the air officer shall normally be responsible for making the recommendation to the commanding officer as to which aircraft should be diverted in the interest of flight safety. The air operations officer shall, if practicable, determine the condition of the navigation, communication, and lighting facilities of divert field prior to the first Case III recovery. The following factors shall be considered when anticipating a divert:

1. Aircraft fuel state
2. Bearing and distance of field
3. Weather at divert field, current and forecast
4. En route upper level winds
5. Suitability of field for type of aircraft
6. Navigational assistance available

7. Aircraft mechanical condition
8. Ordnance restrictions
9. Condition of carrier deck
10. Availability of tankers
11. Pilot performance.

CATCC/CDC shall be alerted to the impending divert of an aircraft or group of aircraft and shall take control of the aircraft when diverted. CDC shall also ensure the ship's lookouts are alerted to the forthcoming divert, model aircraft, side number, and on what relative bearing the aircraft is expected to depart the ship.

When it is determined to divert an aircraft, [approach control](#) shall notify the pilot by passing the following information only: "(call sign) signal divert/bingo, (name of field) passing angles 2.5 go button (XX)." After the switch to departure control once above 2,500 feet, the pilot shall be advised to check gear up/hook up and also have information relayed regarding the magnetic heading and the distance to the divert field. A readback of diverting instructions from the pilot or flight leader is mandatory on departure frequency. While under positive control and en route to the divert airfield, any additional information available shall be provided the pilot concerning latest en route and field weather, squawk, altimeter setting, and position from which divert is being initiated. If operating outside an ADIZ boundary, the CDC controller shall provide the pilot with the necessary ADIZ information. The appropriate Air Defense Sector shall be advised of the diverted aircraft's departure point, ADIZ penetration point, time of penetration, altitude, ETE, destination, and any additional information that may be pertinent to safety of flight. The CDC controller shall maintain a radar plot and radio monitor on all diverted aircraft as long as possible and retain responsibility for the aircraft until positive radar handoff to [FACSFAC/ARTCC](#) or other appropriate controlling agency.

Under IMC, the aircraft shall be instructed to shift to the appropriate airspace controlling agency (FAA or other) frequency after the additional divert information has been received. Once communications have been established with this controlling agency, the flight plan particulars shall be furnished, including the ADIZ penetration information for relay to an air defense sector. The aircraft will receive a clearance. If

NAVAIR 00-80T-105

communications cannot be established, as is often the case, the pilot should file using GCI Common.

The air operations officer shall ensure a divert flight plan is transmitted to the appropriate divert airfield and similar information to the pertinent air defense system agency should an ADIZ penetration be involved; he is also responsible for receipt of an arrival report on the diverted aircraft. The pilot shall ensure an arrival report

is transmitted immediately upon landing via the most expeditious means (i.e., POTS, HF/UHF radio, INMARSAT, immediate message, etc.).

Squadron or unit commanders and the air operations officer are jointly responsible for ensure aircraft performance data pertinent to divert is available to and understood by air control personnel.

COMMAND/ADVISORY	SIGNAL		
	OLS	** ALDIS LAMP	BLINKER
1. *BINGO—Proceed to alternate landing field.	Flashing cut and waveoff lights.	Flashing red light.	M, M — — , — —
2. Add power—(Jets and turbo props only).	Flash, cut lights.	N/A	N/A
3. CHARLIE—Cleared to land aboard.	N/A	Steady green light.***	C — ● — ●
4. DELTA—Delay in landing. Enter DELTA pattern and maintain visual contact with the ship.	Flashing landing area lights.	Steady red light.	D — ● ●
5. Closed deck. Do not land.	Landing area lights off (night only).	N/A	N/A
6. Do not land. Ditch or bail out/eject in the vicinity of the ship.	N/A	Z — — ● ●	Z — — ● ●
7. LSO has control of the aircraft on final approach at approximately 1-1/2 miles.	Steady (3 sec), cut lights.	N/A	N/A
8. Lower hook.	N/A	H ● ● ● ●	H ● ● ● ●
9. Lower wheels.	N/A	W ● — —	W ● — —
10. Lower flaps.	N/A	F ● ● — ●	F ● ● — ●
11. Jettison disposable fuel tank.	N/A	G — — ●	G — — ●
12. Jettison ordnance.	N/A	Q — — ● —	Q — — ● —

* Signal is given only when ordered by the Air Officer.

** Aldis lamps may be located in the tower, or on the signal bridge.

*** Helicopters will normally receive this signal from the rotating beacon or ALDIS lamp on the starboard side of the island.

WARNING

Extra care must be exercised in identifying the correct light and location of signal. Misinterpretation of the lighting signals from other sources can occur. Such sources are rotating beacons (aft, port, forward sides of island), or deck status lights (located at LSO platform and near portside midships catwalk).

Figure 5-9. Visual Signals to Aircraft From Ship Under EMCON or Lost Communications

EMERGENCY	CARQUALS	DEPLOYED/REFRESHER
1. Landing aids malfunction, under steady deck conditions, due to improper stabilization.	Discontinue landings.	Rig MOVLAS and continue recovery with radio as backup.
2. Complete landing aids failure/damage.	Discontinue landings.	If available, consider the use of an emergency field. If none is available and aircraft fuel state does not permit delay: <ol style="list-style-type: none"> 1. Establish positive radio contact with each aircraft when commencing approach. 2. Use radio talk-down as primary control. 3. Have flare gun ready for instantaneous use.
3. Partial failure or damage of OLS, datum lights operative.	Discontinue landings.	Rig MOVLAS and continue recovery, with radio as backup.
4. Waveoff lights inoperative.	Discontinue landings.	Continue landings with radio as primary means of waveoff. Have flare gun ready for instantaneous use as a backup.
5. Suspected malfunction, when consecutive approaches result in below glidepath conditions.	Discontinue landings until a thorough check of OLS settings and monitoring equipment is accomplished.	Rig MOVLAS and continue recovery with radio as backup. A complete check of the OLS settings and monitoring equipment will be made upon completion of recovery.
6. Aircraft at night, no approach light.	Aircraft without an approach light shall be waved off for visual check of the landing gear and hook.*	Same as for CARQUALS.
7. Any part of the aircraft striking the ramp or ship's structure other than the normal flight deck protrusions (cross-deck pendant, flight deck light covers, ILARTS head, waist catapult ramp).	Do not attempt normal arrestment.	Same as for CARQUALS.
8. Tanker drogue extended (guillotine inoperative).		Divert if suitable field available. If situation prevents divert, jettison external store. If divert not feasible or jettison unsuccessful, utilize normal arrest landing procedures.
* For F-14 aircraft, simultaneous illumination of at least one wingtip and one glove position light may be substituted for an approach light. For all multiposition aircraft (except EA-6 aircraft) where cockpit configuration permits at least two crewmembers to visually confirm landing gear indications, verbal confirmation of "gear down and locked" may be substituted for an approach light.		

Figure 5-10. Carrier Pattern Emergencies

EMERGENCY	CARQUALS	DEPLOYED/REFRESHER
1. Loss of LSO radios.	Discontinue landings. Advise air officer to initiate DELTA or bingo instructions, as appropriate.	Pri-Fly notify aircraft in pattern that LSO radio is out, and transmit "Waveoff" if LSO uses waveoff lights.
2. Loss of all ship's radios.	Discontinue landings. Use visual signals on OLS or from the LSO platform to DELTA or bingo, as appropriate.	Continue landings at discretion of the OTC.
3. Loss of aircraft radios.	<p>With receivers:</p> <ol style="list-style-type: none"> 1. Pilots shall be given landing instructions and aircraft shall remain aboard when arrested. 2. Pri-Fly shall transmit bingo fuel states each time the aircraft approaches abeam. Pilot shall acknowledge by rocking wings. 3. If unable to get aboard, pilot shall bingo when fuel state dictates. Another aircraft should be designated as an escort. <p>With no receiver, aircraft should not be diverted.</p>	With or without receiver, make normal approach and landing.
<p style="text-align: center;">Note</p> <p>Information and instructions should be transmitted to no-radio (NORDO) aircraft on control frequencies and guard.</p>		

Figure 5-11. Day Communication Emergencies

EMERGENCY	CARQUALS	DEPLOYED/REFRESHER
<p>1. Loss of LSO radios.</p> <p>2. Loss of all ship's radios.</p>	<p>Discontinue landings. Give DELTA or bingo instructions, as appropriate.</p> <p>Discontinue landings. The flight leader of each unit airborne should organize a flight of his unit members and proceed to divert field.</p>	<p>The LSO shall inform CCA, via sound-powered phone, of the radio failure. The LSO shall accept control of each aircraft from CCA, via sound-powered phone, as the aircraft reaches approximate meatball acquisition position. At this time CCA shall transmit to the pilot of each aircraft that the LSO has assumed control of the approach.</p> <p>Continue final landings or bingo at the discretion of the OTC. Use standard visual signals on the OLS, or from the LSO platform, or from PriFly, as appropriate.</p>
<p>3. Loss of aircraft radios.</p>	<p>With receivers:</p> <ol style="list-style-type: none"> 1. Pilot shall be given landing instructions and aircraft shall remain aboard when arrested. 2. CATCC shall transmit bingo fuel state each time the aircraft commences approach. 3. If unable to get aboard, pilot shall bingo when fuel state dictates. Another aircraft should be designated as an escort. <p>With no receiver, aircraft should be diverted.</p>	<p>With escort:</p> <ol style="list-style-type: none"> 1. Lead pilot calls "Ball" and receives normal reply from the LSO. 2. After receiving acknowledgment, lead pilot makes the appropriate light signal, breaks off to the left, then parallels the final bearing, allowing the no-radio aircraft to continue approach visually. The no-radio aircraft shall receive cut lights from the LSO following breakaway. 3. Lead pilot shall be in a position to be rejoined by the no-radio aircraft in the event of a bolter or waveoff. <p>With no escort:</p> <ol style="list-style-type: none"> 1. Pilot makes the approach with lights as indicated in Figures 5-9 and 5-10. 2. Pilot squawks the appropriate code on IFF/SIF. 3. LSO shall acknowledge positive control of the no-radio aircraft by the cut light signal. An aircraft with transmitter only receives the same acknowledgment as the no-radio aircraft. 4. Pilot shall execute his own waveoff without acknowledgment. <p>Without escort and external lights:</p> <ol style="list-style-type: none"> 1. Pilot shall squawk the appropriate mode IFF/SIF and commence a normal approach, but shall not land without visual acknowledgment by the LSO. 2. If visual acknowledgment is not received, pilot shall execute a normal waveoff into the bolter pattern, except priority in the pattern and visual acknowledgment on the next approach. 3. Cut lights when used as an acknowledgment signal shall be given as near the normal meatball reporting position as possible.

Figure 5-12. Night Communication Emergencies (Sheet 1 of 2)

EMERGENCY	CARQUALS	DEPLOYED/REFRESHER
<p>4. Complete electrical failure.</p>		<p>1. If the carrier can be sighted and a safe descent and landing approach made, fuel permitting, orbit keeping the carrier in sight and descend so as to be at the ship during the scheduled recovery and/or descend and fly by ship giving appropriate emergency signal (Figures 5-9 to 5-11).</p> <p>2. If the carrier cannot be located, the pilot should DR navigate to the prebriefed "emergency sector/radial" and hold. If not joined by or unable to join on any escort aircraft, upon reaching bingo fuel, divert to bingo field if available.</p> <p>3. If no bingo field is available, commence DR descent/penetration to ship at approximate approach time, weather and common sense permitting. If after descent ship is not sighted, commence square search if practical.</p> <p>4. If the carrier or potential rescue ship is not sighted or if the aircraft/weather combination precludes a descent, take DR heading to nearest land. If land is reached, hold at recommended ejection/bailout altitude and continue watching for escort; when fuel nears exhaustion, make controlled ejection/bailout.</p>
<p style="text-align: center;">Note</p> <p>Information and instructions should be transmitted to no-radio (NORDO) aircraft on control frequencies and guard.</p>		

Figure 5-12. Night Communication Emergencies (Sheet 2 of 2)

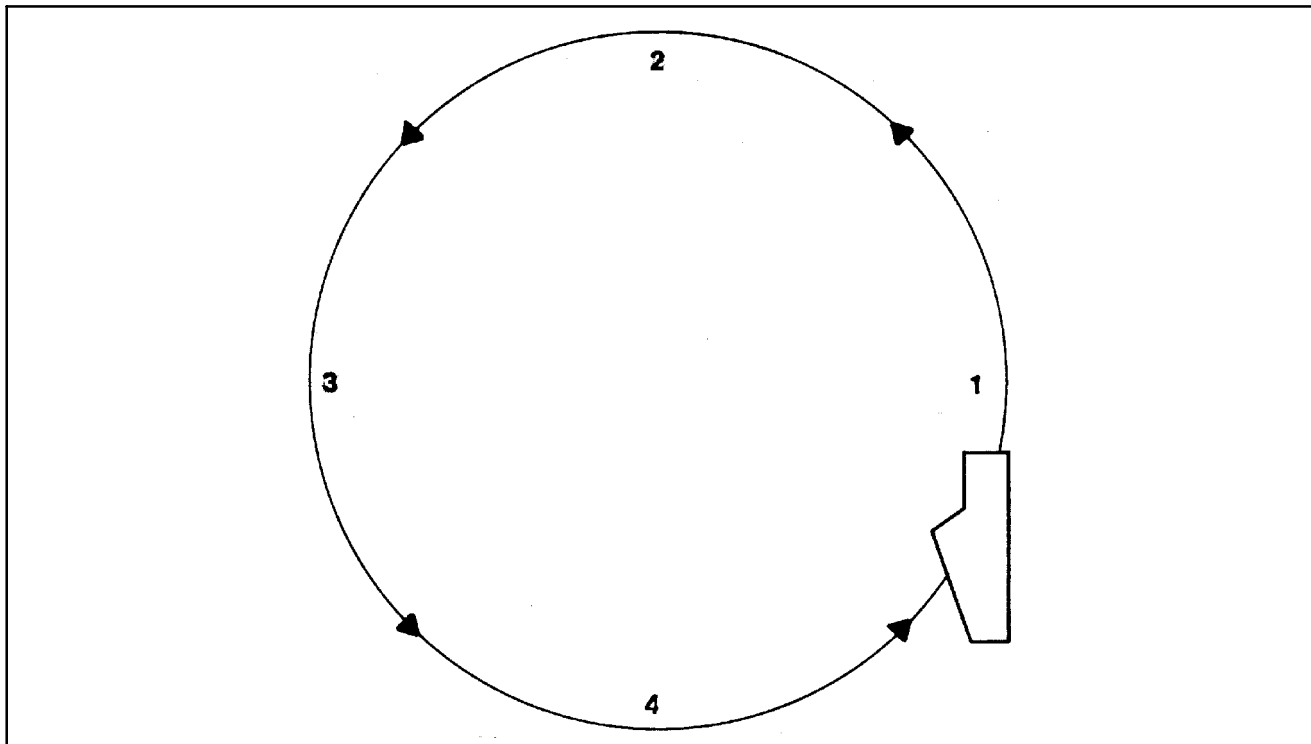

Figure 5-13. Tanker Rendezvous Pattern

CHAPTER 6

Aircraft and Weapons Handling Procedures

6.1 GENERAL REQUIREMENTS

All aircraft movement shall be controlled by designated aircraft directors. Aircraft shall be moved only with the express authority of either the air officer, aircraft handling officer, flight deck officer, hangar deck officer, or air department duty officer except in cases of emergency. Aircraft handling personnel are specifically charged with the responsibility of reporting to higher authority any observed unsafe practices or any condition that may affect the safety of personnel or equipment.

Note

The abrasive qualities of the flight/hangar deck nonskid shall be maintained in good condition. Accumulated oils, grease, etc., shall be cleaned from the flight/hangar deck periodically or when dangerous conditions exist.

When the ship is at flight quarters, the OOD shall ensure all anticipated turns are passed to PriFly with sufficient lead time to enable deck crews to secure aircraft movement/position aircraft accordingly.

It is the responsibility of the aircraft handling officer to begin a respot early enough to avoid unnecessary haste; however, when aircraft are airborne, the desirability of maintaining a ready deck for as long as possible should be kept in mind. The tempo of aircraft movements shall be governed by the deck stability, prevailing winds, weather conditions, and nonskid conditions. Primary consideration shall be given to safety of personnel.

During aircraft arming and dearming evolutions, the area ahead of and immediately behind the aircraft shall be kept clear.

Communications incident to aircraft handling must be in accordance with the existing EMCON condition.

6.2 BRIEFING

Prior to any major respot, the aircraft handling officer shall brief the flight deck officer, hangar deck officer, and other key aircraft handling personnel. This briefing shall include expected wind and deck conditions and any other information pertinent to safety.

6.3 MAINTENANCE LIAISON

It is imperative that the aircraft handling officer be provided accurate information regarding the status as well as the existing and expected maintenance requirements (tail pull, wingspread, blade track, etc.) of every aircraft on board. For this purpose, aircraft status and maintenance request boards shall be maintained in flight deck control.

An air wing maintenance liaison officer or his representative will be on duty at all times during flight quarters or general quarters. His primary duty is to ensure the aircraft handling officer is kept continuously apprised of aircraft status and maintenance requirements and to maintain liaison between the air department and squadron line and maintenance personnel. His normal station is flight deck control; however, he is free to move about the flight and hangar decks as necessary to perform his duties.

Changes in aircraft status will channel through the air wing maintenance liaison officer and shall be entered on the aircraft status board. Entries and changes to the maintenance request board shall be handled in the same manner. To assist the air wing maintenance liaison officer in the performance of his duties, the following is required of the squadron maintenance officers.

1. Provide the air wing maintenance liaison officer with a complete aircraft status report prior to scheduled flight quarters or as early as possible during unscheduled flight quarters or general quarters. This report must show aircraft status, discrepancies on "down" aircraft, estimated time of repair, special requirements for maintenance,

any fuel other than JP-5 on board, and any additional information of interest to the aircraft handling officer.

2. Immediately report all changes in aircraft status to the maintenance liaison officer.
3. Immediately following each recovery, report the status of all aircraft just recovered and advise whether or not "down" aircraft can be repaired before the next launch.
4. Periodically during flight operations, and as soon as possible after the final recovery, verify the maintenance request board.

The air wing maintenance liaison officer is responsible for the overall performance of plane captains and troubleshooters. He shall ensure no aircraft is placed on jacks or otherwise immobilized without permission from the aircraft handling officer. He shall also obtain permission for engine maintenance turnups from the aircraft handling officer or integrity watch officer, as appropriate.

Maintenance functions involving electronic emissions will be limited by existing EMCON conditions.

6.4 EQUIPMENT

The flight deck officer is responsible for ensuring all tractors, mobile firefighting equipment, towbars, chocks, and other equipment used in the handling of aircraft on the flight deck are in satisfactory condition and are properly utilized. The hangar deck officer has a similar responsibility with regard to the equipment used on the hangar deck.

Tractor drivers shall under no circumstances operate a tractor with defective brakes or steering. Discrepancies shall immediately be reported to competent authority.

Note

Crash and salvage crews shall not be utilized as tow tractor operators during aircraft start, launch, recovery, and respot operations.

Defective towbars, chocks, and tiedowns shall immediately be taken out of service and turned in for repair. Towbars, chocks, and tiedowns not in use shall be neatly stowed in designated stowage spaces. Each squadron shall provide its plane captains with canvas bags or other suitable containers for tiedown stowage. Tiedowns removed from an aircraft being moved shall not be hung from any part of the aircraft because of the hazard presented to personnel and equipment.

6.5 MOVEMENT OF AIRCRAFT

In preparing to move an aircraft (taxi, tow, by hand), the director shall ensure the following:

1. The cockpit is manned by a qualified brake rider.
2. The towbar is securely attached to the aircraft and to the tractor or, if the aircraft is to be moved by hand, he shall ensure the towbar is properly tended by another director or specifically designated towbar man.



WARNING

Towing of turboprop aircraft with an engine running is prohibited. The towing of other aircraft with engines running is hazardous. This practice should be avoided whenever possible.

3. All chocks, tiedowns, power cables, and other servicing/securing devices are removed prior to moving the aircraft.



CAUTION

Tiedowns and chocks shall not be removed prior to attachment of the towbar to the tractor.

4. If weapon loading/downloading is in progress, assurance is received from the ordnance crew leader that the aircraft is safe to move insofar as weapons are concerned.
5. Adequate clearance exists to permit safe movement.

6. Safety men are posted as required to ensure clearance if in close proximity to other aircraft, bulkheads, or obstructions.
7. The qualified brake rider signifies he has checked the aircraft brakes, that adequate braking pressure is available, and they appear to be in proper working order.
8. All personnel except those necessary for the move are well clear of the aircraft.

8. Utilize available safety equipment such as safety belts, shoulder harness, life preservers, etc.

Before having the chocks and tiedowns removed, the director shall call for “brakes” and receive visual or verbal confirmation from the man in the cockpit that the brakes are being held. The aircraft tailwheel shall be unlocked only on signal from the director.

While aircraft are being moved, the following shall occur:

1. Movement shall be slow enough to permit a safe stop to be made within the clear space available and in no case faster than the chock men can walk.
2. The director shall ensure he or another director is at all times plainly visible to the man in the cockpit. If the man in the cockpit loses sight of his director, he shall stop immediately.
3. Safety observers shall be stationed as necessary to ensure safe clearance anytime an aircraft will pass in close proximity to another aircraft, bulkhead, or other obstruction. Only directors or personnel specifically designated by the flight deck officer or hangar deck officer shall act as safety observers. The safety observer and the director in control of the aircraft must either have each other in sight at all times or have a second safety observer stationed in a position to relay signals. At least one safety observer is required for each aircraft movement on the hangar deck.



Working or passing beneath a moving aircraft is extremely hazardous. This practice is prohibited except for catapult hookup, recovery operations, chock walking, and emergencies.

In manning the cockpit of an aircraft to be moved, the qualified brake rider shall perform the following:

1. Ensure ejection seat safety pins are installed and safety pins are in place in the landing gear/ auxiliary tanks as appropriate.
2. Adjust the seat and rudder pedals as required to ensure the ability to fully apply the brakes and see the director at the same time.
3. Ensure the windshield and side panels are clear of grease, cleaning compound, or any other film which might limit visibility.
4. Conditions permitting, open cockpit canopy, windows, or overhead hatches.
5. Ensure adequate braking pressure is available and that the brakes appear to be in proper working order.
6. Remove flight helmet or sound attenuators if worn.
7. Advise the director of any unusual condition or aircraft discrepancy that might make movement hazardous.

Note

Nothing stated above shall be construed to require any individual to place his personal safety in jeopardy. This is particularly applicable at night or during periods of heavy weather.

4. During periods of high winds or when the deck is unsteady, chock men shall closely tend each main wheel. The brake rider shall apply partial brakes as necessary to prevent excess speed from building up. When these conditions prevail, aircraft shall not be moved by hand except in case of extreme urgency.



To prevent inadvertent canopy separation/ structural damage, ensure canopy, windows or overhead hatches are in the full closed and locked position when in the proximity of aircraft under power.

5. Tractor drivers shall not move an aircraft except under the control of a director. If a director's signal is not completely understood, the driver should stop and await further instructions.
6. Sudden stops by tractors towing aircraft must be avoided except in an emergency.
7. Directors shall be equipped with whistles that they will hold in their mouths while controlling aircraft movement. The whistles will be used to signal for brakes and chocks.
8. When an aircraft with inoperative brakes must be respotted, the cockpit shall not be manned and chock men shall remain in position to chock the main wheels instantly if ordered. In addition, men shall be immediately available with tiedowns ready.
9. As an aircraft nears its parking spot it should be slowed to a speed that will permit an immediate stop. Directors and safety observers are responsible for maintaining safe clearance for the tractor when maneuvering in close quarters since the tractor driver must watch the director and is often unable to check the clearance for himself.
10. Prior to backing aircraft to deck-edge spots, chock men shall be positioned so as to enable them to chock the main wheels instantly.



The controlling plane director shall ensure aircraft with wings folded or open canopy are not spotted, towed, or taxied immediately behind a JBD when another aircraft is at high power setting on the catapult.



To prevent inadvertent canopy separation/ structural damage, ensure canopy, windows or overhead hatches are in the full closed and locked position when in the proximity of aircraft under power.

11. When an aircraft towbar has to be repositioned to permit a better path of movement prior to aircraft reaching interim or final spot, the aircraft shall be chocked and initial tiedowns installed prior to disconnecting the towbar.

When the signal for brakes is given, the man in the cockpit shall immediately apply full brakes. Care must be exercised to apply brakes simultaneously, particularly when the aircraft is being moved by hand. The brake signal is a sharp blast on the whistle accompanied by the standard visual signal.

The main wheels will be chocked as soon as the aircraft stops and the director will remain with the aircraft until the handling crew has completed the initial four-point/six-point tiedown. The tractor will then be unhitched and the brake rider notified by the director that he may leave the cockpit. Where practicable, the towbar should remain attached to the aircraft. The plane captain will thereupon inspect attached tiedowns for required number and proper installation.



Special precautions are required when aircraft are parked over expansion joints, JBDs, elevators, catapult tracks, or with the tail skag outboard of the deck edge.

In parking aircraft on the hangar deck, allow clearance for access to and operation of fog foam monitors and fire plugs as well as for the operation of hangar bay doors.



Aircraft containing fuel other than JP-5 shall not be parked on the hangar deck without the commanding officer's approval.

Note

When operational necessity dictates placing an aircraft on the hangar deck containing fuel with a flash point below 140 °F, institute the following minimum procedures:

- a. In order to reduce the extremely dangerous vapor hazard, aircraft should be refueled with JP-5 prior to being placed on the hangar deck.
- b. All hangar bay sprinkling groups located in the hangar bay in which the aircraft are parked will be operable.
- c. An operable MFFV/AFFF hose shall be positioned at a location that will provide coverage of the affected aircraft.
- d. All CONFLAG stations located in the hangar bay with the affected aircraft shall be manned and notified of the fuel situation.
- e. Hot work shall not be conducted in the hangar bay or in close proximity to the hangar bay containing the affected aircraft.

Personnel shall not ride on tractors except in the driver's seat.

When the word is passed to stand by for a turn, exercise extreme caution while moving aircraft.

6.5.1 Elevator Operation. Elevator operation must be coordinated with the maneuvering of the ship. Aircraft elevators shall be operated by designated personnel only. A director/elevator safety petty officer shall supervise the elevator anytime it is being raised or lowered. He shall make sure that he is plainly visible to the elevator operator at all times.



If weapons loading/downloading is in progress, the director shall receive assurance from the ordnance crewleader that it is safe to move the elevator insofar as weapons are concerned.

When the word is passed to stand by for a turn, deck-edge elevators on the side opposite the direction of turn, if not already at flight deck level, shall be raised as soon as feasible.

Any delays shall be reported immediately to the bridge. The aircraft handling officer shall consider the sea state and wind velocity in determining the degree of security required when parking aircraft on deck-edge elevators.

WARNING

Extreme caution shall be exercised when operating deck-edge aircraft elevators during periods of high winds and/or heavy seas.

When sending aircraft to the hangar deck, flight deck directors should position the aircraft on the elevator so that it can be towed directly into the hangar bay without repositioning.

Elevators and stanchions should not be operated in the automatic mode. Guardrail (stanchion) and elevator operation are two distinctly separate functions that require coordination. Before signaling the elevator to be raised or lowered, the director shall check the stanchion for clearance, then signal for it to be raised or lowered. If obstructions prevent raising of stanchions to full height, desired partial positions shall be prebriefed prior to commencement of the evolution. The elevator operator will then sound the warning horn, check to ensure all personnel are clear, and raise the stanchions. As soon as the stanchions are up and after ensuring locks are retracted, the director will signal for the elevator to be raised or lowered. If the stanchions are inoperative, safety observers shall be stationed near the elevator to warn approaching personnel and a temporary safety line shall be rigged as quickly as possible. The warning horn shall be sounded three times prior to elevator movement and continuously throughout the elevator cycle. On low-speed operations, warning horns shall sound a 5- to 10-second blast every 20 to 30 seconds. After the stanchions have been raised or the warning given, no person shall attempt to board or leave the elevator.

WARNING

Extreme caution shall be exercised when operating aircraft elevators when stanchions are inoperative.

Elevators shall remain at hangar deck level for as short a time as possible. An elevator carrying an aircraft to the hangar deck shall not be lowered until it has been ascertained that a crew is standing by to remove the aircraft from the elevator as soon as it arrives at hangar deck level.

Elevators shall not be operated without two-way communication, either verbal or visual, between operators.

All personnel who ride an elevator between the flight deck and hangar deck when the ship is underway shall wear floatation gear except during launch and recovery when full flight deck gear shall be worn.

6.5.2 Report of Damage to Aircraft. Any damage to an aircraft, no matter how slight, shall be immediately reported to the safety officers, aircraft handling officer, flight deck officer, or hangar deck officer who shall immediately report the incident to the air officer and inform the air wing maintenance liaison representative. The aircraft shall not be flown until it has been inspected and declared to be in an “up” status by authorized squadron personnel.

The flight deck officer and hangar deck officer shall maintain a record showing director’s name, model aircraft, bureau number, and a brief summary of circumstances for occurrences in which aircraft are damaged, regardless of the extent of damage. Reports of these occurrences shall be made in accordance with OPNAVINST 3750.6 series and COMNAVAIRLANT/COMNAVAIRPAC 3100.4 series.

6.5.3 Aircraft Security. Aircraft shall be tied down as directed by the aircraft handling officer or his representative. Unless otherwise specified, chain tiedowns shall be used exclusively. Tiedowns must run from a proper tiedown fitting on the aircraft to a padeye on the deck without pressing against oleo struts, hydraulic lines, tires, or any other portion of the aircraft. When an aircraft is spotted adjacent to an elevator,

tiedowns shall not be attached to the elevator. Tiedowns shall never be attached to catapult tracks or holdback fitting cleats.

Tiedowns will be removed only when signaled by an aircraft director. They shall be affixed to aircraft to preclude movement in any direction. This requires that they tend to oppose each other. They should be as equally distributed on the aircraft as possible.

Tiedown requirements are divided into three categories, dependent upon aircraft type, that under normal conditions may be defined by the following minimums.

1. Initial (four-point/six-point) tiedown — Required immediately after an aircraft is parked or immediately preceding movement of an aircraft.
2. Intermediate (six-point/nine-point) tiedown — Required during flight quarters when aircraft may be expected to be moved for respot.
3. Permanent (twelve-point or greater) tiedown — Required when not at flight quarters.

The aircraft handling officer will order an increase in the number of tiedowns required in each of the above categories when such action is indicated because of aircraft model, expected wind, sea state, or ship’s maneuvers.

6.5.4 ILARTS Special Events Coverage. During all unusual events or events out of the ordinary, such as crash and salvage operations, fires or other disasters, or any other event that could require a record of proceedings, the air officer shall ensure the ILARTS is manned and operating.

6.6 VERTICAL REPLENISHMENT

A qualified LSE shall be utilized on board the CV for VERTREP operations. The carrier must ensure all breakdown crews remain clear of the drop zones and that pallets are not broken down in the vicinity of the drop zone to preclude cargo from being blown down the deck by rotor wash.

Radio transmissions to the VERTREP helicopter should be minimized to prevent a breakdown of ICS communications between the pilot and the aircrewman directing the load.

Refer to NWP 14, Replenishment at Sea, and NWP 3-04.1, Shipboard Helicopter Operating Procedures, for VERTREP procedures, and Chapter 3 of the Aircraft Signals NATOPS Manual (NAVAIR 00-80T-113) for helicopter hand signals.

6.7 FUELING AND DEFUELING AIRCRAFT

The air officer is responsible to the commanding officer for supervising and directing the receipt, stowage, and dispensing of aviation fuels as well as the maintenance and security of the aviation fuel system and the enforcement of safety precautions. An effective aviation fuel quality control program is a vital part of the aviation fuel system management.

The aviation fuel officer is responsible to the air officer for efficient and safe operation of the aviation fuel system and for the management of the aviation fuel quality control program. He is further responsible for ensuring strict compliance with the Aircraft Refueling NATOPS manual (NAVAIR 00-80T-109) and all applicable directives concerning the inspection, maintenance, and operation of aviation fuel systems.

WARNING

Prior to aircraft recovering aboard the CV with fuel other than JP-5, the air officer shall be notified to ensure compliance with the Aircraft Refueling NATOPS (NAVAIR 00-80T-109) and individual aircraft NATOPS manuals.

6.7.1 Fueling and Defueling. Aircraft are normally fueled as soon as possible after recovery. It is the responsibility of each plane captain to notify the air wing maintenance coordinator in flight deck control if it becomes apparent that the fueling crew has missed his aircraft. It is also the plane captain's responsibility to request that his aircraft be topped off as necessary after a maintenance turnup.

WARNING

- When electrical storms are within a 5 mile radius of the ship, all exposed refueling evolutions shall cease.
- Oxygen servicing, other than converter replacement at the aircraft, and fueling shall be conducted as separate evolutions.

Aircraft are fueled in exact compliance with the air plan. In the event a squadron desires a fuel load other than that specified in the air plan, a request must be made to air operations that the air plan be changed to show the fuel load desired. No person in the air department can authorize any deviation from the fuel requirements in the air plan as published or modified by air operations. Requests for the defueling of aircraft for maintenance purposes shall be made to the aircraft handling officer via the air wing maintenance liaison officer and the aviation fuels maintenance officer.

Fueling shall be conducted in a manner that will cause a minimum of interference with aircraft respot. Prior to the recovery, fueling crews shall be standing in or near their stations to break out hoses and start fueling aircraft. Aircraft and fuel hoses shall be properly grounded before fueling and all ground wires removed after fueling is completed. The aviation fuel officer shall ensure the appropriate smoking lamp condition is set before fueling or defueling.

The plane captain is responsible for the correct fuel load and for security of the filler caps. The fuel control talker maintains the fuel status board in flight deck control. This board shall list each aircraft on board and shall show its exact fuel load.

Spilled fuel shall immediately be swabbed up and the incident reported to the aircraft handling officer.

6.7.2 Hot Refueling. Hot refueling of jet aircraft, helicopters, and turboprop aircraft shall be accomplished with the permission of the commanding officer or his duly authorized representative, usually the

air officer. In each instance of hot refueling, it shall be the responsibility of the air officer to inform the pilot of the intended fuel load. In the instances where hot refueling and a pilot switch are being conducted, the new pilot will be informed of intended fuel load. In all cases, aircraft NATOPS prescribed hot refueling procedures shall be followed. Aircraft shall be chocked and have the initial (four-point/six-point) tiedown applied. Aircraft shall be chocked and have intermediate tiedown requirements applied during crew switch evolutions.

WARNING

Only pressure hot refueling is authorized. Where feasible, the engine with the propeller or intake nearest the aircraft fueling receptacle shall be secured. Engines of an aircraft shall not be started while fueling hose is connected to an aircraft.

6.8 WEAPON HANDLING PROCEDURES

Airborne weapon handling evolutions introduce a degree of risk in carrier operations that requires careful planning and preparation. The necessity to train for and to conduct combat operations requires the acceptance of certain risks that cannot be avoided in the handling of explosive weapons. Commanding officers shall continually weigh the requirement to perform each weapon evolution against the additional risk that is being interjected and accept only those evolutions in which the need clearly outweighs the risk. The Air Gunner/CVW Ordinance Officer shall ensure adequate ordinance supervision is maintained during all flight deck ordnance handling evolutions.

WARNING

Prior to the execution of any drill, specific consideration shall be given to ensure the drill (scheduled or unscheduled) will not compromise ordnance handling safety.

Note

- During all ordnance handling evolutions above the second deck, compliance with

the AFFF system and mobile firefighting equipment information in NAVAIR 00-80R-14 is mandatory.

- During ammunition replenishments, the application of electrical power for aircraft maintenance is authorized, provided electrical power is applied in accordance with the existing model MIMs and electrical power cables do not obstruct the movement of ammunition.
- Announced drills shall not be conducted during ammunition replenishment.

6.8.1 Weapon Definitions

1. Airborne stores — Tanks (fuel and spray), pods (refueling, photo, ECM, and so forth), nonexpendable training weapons, targets, and all similar items intended for carriage internally or externally by aircraft, including the racks, launchers, adapters, and detachable pylons used for such carriage. This definition applies to items that are not normally separated from the aircraft in flight.
2. Airborne weapons — All missiles, rockets, bombs, mines, torpedoes, pyrotechnics, ammunition, guns and gun pods, and all similar items intended for carriage internally or externally by aircraft. This definition applies to items that are normally separated from the aircraft in flight.
3. Arming — An operation whereby a weapon is changed from a safe condition to a state of readiness for initiation.
4. Arming area — That area where forward firing ordnance is changed from a safe condition to a state of readiness. All arming evolutions required to be accomplished in the arming area by the aircraft store loading manual/checklist shall be performed in this area. Before arming commences and until aircraft launch, the area in front of and behind the aircraft (forward of the raised JBD) shall remain clear.
5. Dearming area — That area where forward firing ordnance is changed from a state of readiness to a safe condition. All dearming evolutions required to be conducted in the dearming area by the individual store loading manual/checklist will be

conducted in this area. The area ahead of and behind the aircraft must be kept clear until safing is completed. When taxiing aircraft from the landing area to the dearming area, care must be taken to minimize exposure of the armed forward firing ordnance to personnel and equipment.

6. Downloading — An operation that removes airborne weapons/stores from an aircraft.
7. Hung weapons — Those weapons or airborne stores on an aircraft that the pilot has attempted to drop or fire in flight but could not be fired or dropped because of a malfunction of the weapon, rack/ launcher, or aircraft release and control system.
8. Harpoon/SLAM/JSOW weapon — A weapon, such as Harpoon or SLAM, for which an **intent to launch** signal has been initiated and whose launch has subsequently been aborted by the aircrew or failed prior to separation of the weapon from the aircraft.
9. Loading (rearming) — An operation that installs airborne weapons/stores on or in an aircraft.
10. Rearming area — That area where an operation is conducted that replenishes prescribed airborne weapons in/on an aircraft or where final dearming is accomplished following recovery and engine shutdown or following ground abort. Only loading, downloading, arming, and dearming authorized to be conducted in the rearming area by the individual store loading manual may be conducted in this area. All weapons handled or loaded in the rearm area shall be safe and remain safe.
11. Safing (dearming) — An operation whereby a weapon is changed from the state of readiness for initiation to a safe condition.
12. Unexpended weapons — Weapons that have not been subjected to attempts to fire or drop. They are presumed to be in a normal operating condition and can be fired or jettisoned if necessary.

6.8.2 Weapon Movement. The presence of airborne weapons outside of designated magazines greatly increases the danger to the carrier should a fire or explosion occur. The greater the quantities of weapons involved, the greater the risk. To minimize this risk, only that quantity of weapons required to sustain

operations shall be transferred to the hangar or flight deck.

With exception to actual loading evolutions, weapons on skids/trucks shall be positioned fore and aft and continuously attended.

Airborne weapons shall be positioned in such areas as to be readily available to afford adequate time for safe aircraft loading. Staging areas for assembled weapons shall be restricted to those areas that:

1. Are convenient to jettison locations
2. Have at least two clear routes of access
3. Are covered by sprinkler system or manned firehoses
4. Are located as far as practicable from fueling stations and LOX carts
5. Are manned and have provisions for physically securing weapons.

The priorities that shall be utilized in locating staging areas for weapons include the following:

1. Flight deck outboard of island
2. Hangar deck
3. Sponsons.

Staging areas shall be used for ready service only, not for protracted stowage nor for extending the total weapons stowage capacity of the ship. All weapons in staging areas shall be on mobile trucks/skids.

All ordnance jettison ramps will be exercised daily prior to flight operations involving ordnance. Jettison ramps in the ordnance staging area will be rigged at all times that ordnance is present. All other ramps will be rigged when required as determined by the Air Gunner.

The aircraft elevators may be used to supplement and expedite transfer of weapons from the hangar deck to the flight deck. Coordination between the ordnance handling officer and the aircraft handling officer is necessary.

6.8.3 Weapon Loading/Downloading.

Guidance for weapon loading/strikingdown/downloading is provided in Appendix C.

Compliance with the weapon requirements contained in the ordnance load plan demands close coordination between the aircraft handling group, ship's ordnance group, and air wing ordnance

personnel. The Air Gunner shall maintain a status board that confirms type, quantity, and location of all weapons on the flight deck and/or aircraft. It is of particular importance that the aircraft handling officer be apprised of any peculiarities in configuration or status that may make certain aircraft unassignable for particular types of weapon loading.

The aircraft handling officer shall designate the aircraft to be loaded after coordination with squadron maintenance representatives. He shall provide ordnance personnel with the planned deck spot as early as possible to afford adequate time for required configurations and the performance of aircraft release and control system checks.

Simultaneous fueling, loading, and downloading of weapons, preloaded IMERS/ITERS, "PASE" weapons, and installation of fuzes and arming wires is authorized.

WARNING

- Loading/downloading and oxygen servicing, other than converter replacement at the aircraft, shall be conducted as separate evolutions.
- Refueling hoses shall not be connected to an aircraft which is undergoing the Loading/Downloading of ordnance requiring electrical connections to the aircraft weapons system (i.e., installation/removal of umbilical cables, mating/unmating of buffer connector/wafers and rocket motor firing contacts).
- No electrical connections to weapons or removal/installation of impulse cartridge shall be accomplished while fueling of that aircraft is in progress. Fuel hoses shall not be positioned under weapons being loaded/ downloaded.
- When electrical storms are within a 5-mile radius of the ship, all exposed ordnance evolutions shall cease until the condition clears the 5-mile radius. Ordnance handling shall be limited to the dearming of recovering aircraft during atmospheric disturbance.

When required, electrical power may be applied during the aircraft loading/downloading evolution but

will be held to a minimum consistent with [operational commitments](#). Electrical power to the armament or weapon release and control circuitry shall not be applied while weapons are being loaded/downloaded.

The flight deck is always the preferred area to load aircraft. Loading is permitted while recovery of aircraft is in progress. However, all efforts shall be made to ensure the movement of ordnance does not impede the safe and efficient recovery and movement of aircraft. In any event, only the minimum quantity of weapons required shall be moved toward the bow during recovery operations.

Note

The preferred area to load AGM-114 Hellfire is spot 3 or 4.

Properly equipped EOD/weapons personnel shall be stationed in flight deck control to provide technical assistance and weapon disposal. The Air Gunner/air wing ordnance officer shall maintain a status board that confirms type, quantity, and location of all weapons on the flight deck and/or aircraft. Additionally, weapon cookoff times shall be conspicuously posted in plain view of the aircraft handling officer.

Loading limited amounts of weapons on the hangar deck may be authorized by the commanding officer when the operational necessity so dictates the acceptance of the additional risk of fire with fuel and explosives in a confined area. Authorization for loading on the hangar deck shall be limited to those aircraft scheduled for the next launch or on an alert condition, and is restricted to the particular weapons indicated in Appendix C.

WARNING

- Personnel shall not approach an aircraft to perform weapons system checks while the engine(s) is turning until cleared to do so by the ordnance arming supervisor. The ordnance arming supervisor shall be positioned in full view of the pilot and shall have the pilot's attention.
- Aircraft shall not be taxied until pretaxi checks and required procedures prescribed in the appropriate NAVAIR weapon/store loading checklists/SRCs have been completed.

Note

- The mechanical latching on aircraft racks/launchers shall be completed before the engine(s) on that aircraft is started for launch.
- Inert conventional weapons and captive air-launched missiles shall be loaded/downloaded and armed/dearmed in the same manner as live weapons.

6.8.4 Arming. Weapons/bomb racks/launcher arming functions to be performed after engine turnup are defined in the individual store loading manual/checklists. Final arming of forward firing weapons shall be conducted in the arming area just prior to launch.

All evolutions authorized in the rearming area may be accomplished after engine turnup and prior to taxi. Those evolutions authorized to be accomplished only in the arming area shall be conducted as follows:

1. The Air Gunner or a designated air wing ordnance coordinator shall supervise all arming evolutions.
2. Assigned Air Wing Arming coordinators shall be positioned on the bow and waist catapults during launch to oversee all aircraft final arming.
3. The CVW Ordnance Officer shall assign arming crews.
4. Each arming crew shall be supervised by a safety coordinator who will coordinate actual arming with aircraft crew director.
5. Aircraft arming shall be conducted only when the aircraft is at a complete stop, the area in front of the aircraft is clear and remains clear, and only after the director has turned the aircraft over to the arming crew safety coordinator.
6. Actual arming may take place at any time after the following conditions are met: The aircraft is forward of the raised JBD, flaps are in the takeoff position, the nose launch bar is resting on the top of the shuttle, and all personnel are clear of the missile path.

WARNING

Arming crews shall use extreme caution when exiting an armed aircraft to avoid exposure to exhaust end of missiles, gun barrels, and aircraft intake/exhaust. Exit paths for each type aircraft will be formalized by the Air Gunner/CVW ordnance officer to provide the least hazard to arming crewmembers.

7. Arming signals shall be in accordance with [Chapter 5](#) of the Aircraft Signals NATOPS Manual (NAVAIR 00-80T-113).

6.8.5 Intent to Launch Weapons. Harpoon/SLAM/JSOW is an automatic launch sequence that has been initiated and subsequently been aborted by the aircrew prior to weapon separation from the aircraft. A Harpoon/SLAM/JSOW shall be considered as a hung weapon whenever a Harpoon/SLAM/JSOW signal has been sent to the missile and it has then either failed to release or its release has been aborted prior to separation of the weapon from the aircraft.

If a JSOW Intent To Launch (ITL) is verified, wait two hours before proceeding with unloading. After two hours, disconnect weapon adapter cable. If weapon must be downloaded prior to two hours elapsed time from ITL, wrap cargo strap or aircraft tiedown chain around weapon and wings approximately 3 inches aft of adapter cable receptacle.

WARNING

- Initiation of the ITL signal activates a battery within Harpoon/SLAM. With battery power available within the missile, electrical shorts occurring during aircraft recovery and/or while disconnecting the missile umbilical from the aircraft may actuate the missile engine/pyrotechnics. Battery voltage will remain sufficiently high to allow engine start for up to 35 minutes following ITL and to fire missile launch squibs within Harpoon/SLAM for up to 2.5 hours following ITL.

- Voltage in the JSOW will remain sufficiently high to allow wing deployment if the umbilical is disconnected.

Ships/squadrons shall prepare and publish Harpoon/SLAM/JSOW abort/failure procedures as standard operating procedures that shall be used by aircrew, aircraft handling, and maintenance personnel whenever Harpoon/SLAM/JSOW abort/failure situations occur.

6.8.6 Hung/Unexpended Weapons. Flight leaders shall advise the ship as early as possible of the amount, type, and, when applicable, the Harpoon/SLAM/JSOW abort/failure elapsed time of hung or unexpended weapons in the flight. Guidance as to whether or not to recover an aircraft with hung/unexpended weapons is provided in Appendix C.

The pilot shall advise the ship in **marshal** that he has hung or unexpended weapons on his aircraft. He shall give marshal a Harpoon/SLAM/JSOW abort/failure time for all Harpoon/SLAM/JSOW. When calling the **ball**, he shall advise that he has hung, unexpended, or Harpoon/SLAM/JSOW weapons on board. For these reports, unexpended weapons do not include those weapons that are routinely returned aboard (such as air-to-air missiles). Only the last (most recent) Harpoon/SLAM/JSOW abort/failure time should be reported to marshal when more than one Harpoon/SLAM/JSOW weapon is present on the aircraft.

The air officer shall announce over the flight deck announcing system when the approaching aircraft has hung or unexpended weapons, stating the aircraft model and type of weapon(s) and, when applicable, the Harpoon/SLAM/JSOW abort/failure elapsed time.



When aircraft are landed with hung weapons, only required personnel shall remain in the vicinity of the landing area. All other personnel shall take cover.



Aircraft with externally carried ordnance shall not perform carrier qualification evolutions because of potential damage to ordnance.

Note

In order to maintain nighttime currency, one (and only one) unarrested (touch and go) landing with captive/live externally carried ordnance does not constitute carrier qualification and is therefore authorized.

6.8.7 Dearming. All dearming evolutions will be conducted in accordance with the individual aircraft store loading manual/checklist. When dearming is required before engine shutdown, all required dearming procedures will be accomplished in the dearming area. All further safing evolutions that are authorized to be conducted after engine shutdown may be accomplished after taxi to the shutdown spot and must be accomplished before respotting to the hangar deck. All dearming required to be accomplished in the dearming area will be accomplished as follows:



The area immediately in front of an aircraft with forward firing ordnance must be clear and remain clear until dearming is completed. Sweeping of personnel/equipment by armed aircraft must be minimal.

1. The Air Gunner or a designated air wing ordnance coordinator shall supervise all dearming evolutions. He shall ensure coordination exists between the directors and dearming crew. He shall indicate to the director those aircraft that require safing before taxi to the recovery spot.

WARNING

Dearming crews shall use extreme care when approaching an armed aircraft to avoid exposure to exhaust end of missiles, gun barrels, and aircraft intake/exhaust. Entry paths for each type of aircraft will be formalized by the CVW Ordnance Officer to assure the least hazard to arming crewmembers.

2. Aircraft dearming shall be conducted as soon as practicable after taxiing clear of the landing area or, if necessary, in the landing area at the discretion of the air officer. Dearming shall be conducted only when the aircraft is at a complete stop, the area in front of the aircraft is clear and remains clear, and only after the director has turned the aircraft over to the dearming crew coordinator.
3. If more than one HH-60 is to be dearmed with AGM-114 Hellfire, the second aircraft will not be permitted to land until the first aircraft is dearmed.

Note

Flight deck helo spot 4 will be primary dearming and spot 3 will be secondary dearming area.

4. The Air Gunner or designated air wing ordnance coordinator supervising dearming shall ensure sufficient safety personnel are positioned to keep the area in front of the aircraft clear.
5. Dearming signals shall be in accordance with [Chapter 5](#) of the Aircraft Signals NATOPS Manual (NAVAIR 00-80T-113).

Aircraft landing with hung weapons and/or forward firing weapons shall be safed as soon as practicable after taxiing clear of the landing area or, if necessary, in the landing area at the discretion of the air officer. They shall be stopped with a clear area ahead when forward firing weapons are involved and safed in accordance with NAVAIR weapons/stores loading checklist and/or EOD emergency procedures, if applicable, prior to being taxied into the recovery spot. Aircraft safing signals shall be in accordance with [Chapter 5](#) of the

Aircraft Signals NATOPS Manual (NAVAIR 00-80T-113).

For the Harpoon/SLAM/JSOW weapon, aircraft respot is prohibited until the after-landing or ground-abort portion of the aircraft store loading manual has been complied with. A 3-foot wide by 8-foot long clear zone shall be established behind the missile; this clear area and the area beneath the missile shall be maintained clear for a 2.5-hour period following Harpoon/SLAM/JSOW.

Aircraft landing with unexpended weapons shall have weapons safed in accordance with NAVAIR weapons/stores loading checklists and in all cases prior to commencement of any postflight checks or refueling of the aircraft.

WARNING

Downloading of aircraft shall not commence until that aircraft's engine(s) is shut down.

6.8.8 Maintenance on Loaded Aircraft.

Maintenance shall not be conducted on aircraft loaded with weapons; however, routine servicing and minor maintenance that would ready the aircraft for the next launch may be conducted with the following restrictions:

1. Weapons shall be safed to the maximum degree as specified in the NAVAIR weapons/store loading checklists.
2. When the weapon loaded placard/sign required by the individual aircraft store/weapon loading manual checklist is in place, the maintenance or servicing of loaded aircraft that requires application of electrical power is limited to the following:
 - a. Refueling
 - b. Replacement and checkout of communication and navigation equipment
 - c. Replacement and checkout of engine performance and flight instruments
 - d. Engine turnup for checkout
 - e. Flight control and hydraulic system checks.

3. Maintenance requiring the application of electrical power to the armament or weapon release and control circuitry shall not be performed while weapons are loaded or are being loaded/downloaded.
4. An aircraft requiring extensive troubleshooting, engine removal, complete jacking, etc., is not considered readily available for flight and shall be downloaded prior to commencement of the required maintenance.

Downloading includes removal of all impulse cartridges from ejector racks/breeches and all rounds of ammunition from feed chutes/feed mechanisms of internal guns.

6.8.9 Abort/Strikedown. The flight deck is always the preferred area for downloading weapons. If it is required to strike below loaded aircraft, weapons shall be immediately downloaded from aircraft after reaching the hangar deck unless that aircraft is the following:

1. Readily available for flight and scheduled for the next launch
2. In an alert condition
3. Requiring only such maintenance or servicing as previously permitted on aircraft loaded with weapons.

In any abort/strikingdown situation, the abort/afterlanding procedures for the particular weapons that are prescribed in the NAVAIR weapon/store loading checklists/SRCs shall be accomplished before the aircraft is moved to the hangar deck.



Bomb rack ejector/jettison cartridges shall be removed from all aircraft stations prior to or immediately after strikedown of the aircraft to the hangar deck. Ejector/ jettison cartridges may remain in the BRU-9/10/11 ejector bomb rack provided the rack is electrically disconnected and either the mechanical safety pin is installed or the in-flight operable bomb rack lock (IFOBRL) mechanism is locked (as applicable).



Certain weapons are specifically excluded from the provisions of this section. Refer to Appendix C for a listing of those weapons that may not be struck below while loaded on an aircraft.

For a Harpoon/SLAM/JSOW abort/failure, respot of the aircraft is prohibited during peacetime operations until 2.5 hours have elapsed from Harpoon/SLAM/JSOW. Under combat/emergency conditions and after 35 minutes from Harpoon/SLAM/JSOW, download prior to completion of the 2.5-hour waiting period is authorized providing the missile is moved to a safe area of the flight deck with the nose-oriented outboard over the deck edge. A safety watch shall be assigned to maintain the safe zone clear. Harpoon/SLAM/JSOW weapons shall not be staged in the normal weapon staging areas, but shall be placed in a separate designated area that meets weapon staging area criteria and is in the immediate vicinity of a jettison ramp. After 2.5 hours of elapsed time, strikedown of a weapon and return to storage is authorized.

6.8.10 Emergency Procedures. In case of fire or danger of fire near weapons, the weapons shall be moved to a safe area or jettisoned as the situation dictates.

1. Armed aircraft returning to the ship with an emergency shall be dearmed immediately after landing in the landing area prior to the aircraft being towed.
2. Aircraft returning with suspected gun jam shall be dearmed in the dearming area and parked in a designated area with aircraft pointing over the water in a safe position for further troubleshooting.

6.8.11 Helicopter Procedures. Helicopters carrying forward-firing ordnance should be pointed clear of aircraft, personnel, and equipment during the de-arming process.

APPENDIX A

Aircraft Handling Signals

These signals are found in Aircraft Signals NATOPS Manual (NAVAIR 00-80T-113) in Chapter 2. Ordering information is found in the preface to this manual.

APPENDIX B

Aircraft Arming and Safing Signals

These signals are found in Aircraft Signals NATOPS Manual (NAVAIR 00-80T-113) in Chapter 5. Ordering information is found in the preface to this manual.

APPENDIX C

Weapons Loading/Strikedown/ Downloading and Recovery Guide

WEAPON	HANGAR DECK		RECOVERY (8)	
	LOAD	STRIKEDOWN/ DOWNLOAD	UNEXPENDED	HUNG
General Purpose Bombs/LGB/JDAM	YES (1) (4)	YES (5)	YES (2)	YES (2)
AGM-154 JSOW	YES (4)	YES (5)	YES	YES
2.75/5.0 Rocket Launchers (all)	NO	NO	YES	NO
Aircraft Parachute Flare (LUU-2B/B)	YES (10)	YES (10)	YES	YES
Tube Loaded Flare Dispenser (Mk 45)	NO	NO	YES	YES
Tube Loaded Flare Dispenser (loaded with LUU-2B/B)	YES (10)	YES (10)	YES	YES
20-mm Guns	YES	YES (6) (11)	YES	YES
Rockeye II/Gator	YES (4)	YES (5)	YES	YES
Sidewinders (all)	NO (3)	YES	YES	YES
Sparrow III (all)	NO (3) (4)	YES (5)	YES	YES
Walleye Weapon (all)	YES (4)	YES (5)	YES (15)	YES (15)
Maverick AGM-65E/F	YES (3)	YES (5)	YES	YES
Phoenix AIM-54 (all)	NO (3)	YES (5)	YES	YES
Harpoon AGM-84/SLAM AGM-84E	NO (3) (4)	YES (5) (12) (13)	YES (12)	YES (14)
Decoy Flare (all)	NO	NO	YES	YES
Mines (all)	YES (4)	YES (5)	YES	YES
Torpedoes (all)	YES (4)	YES (5)	YES	YES
SUS Charge (Mk 64)	YES	YES	YES	YES
Marine Marker (all)	YES	YES	YES	YES
TALD	YES	YES	YES	YES
Practice Bombs (all)	YES (4)	YES (5)	YES	YES
JAU-1B and JAU-22/B Cartridge	YES	YES (8) (9)	YES	YES
25-mm Gun GAU-12	YES	YES (11)	YES	YES
Harm AGM-88A	NO (3)	YES (5)	YES	YES
Chaff (w/cartridge)	YES	YES	YES	YES
GBU-24	YES (4)	YES (5)	NO (7)	NO (7)
Hellfire AGM-114	NO (3)	NO	YES	YES

Notes:

1. No mechanical nose fuzes will be installed on the hangar deck.
2. Arming wires/safety clips intact.
3. Air-launched missiles shall not normally be loaded on the hangar deck except when operational commitments so dictate. Commanding officers may authorize loading of missiles on the hangar deck only up to the point of mechanical attachment of the weapon to the launcher/rack in accordance with the procedures prescribed in the appropriate NAVAIR weapon/store loading checklists.
4. Ejector cartridges shall not be installed on the hangar deck. Installation of ejector/jettison cartridges in the BRU-9/-10/-11/-32 ejector bomb rack is authorized provided the rack is electrically disconnected and either the mechanical safety pin is installed or the IFOBRL mechanism is locked.
5. In the event of strikedown of a loaded aircraft to the hangar deck, the nose fuzes (as applicable) and ejector/jettison cartridges shall be removed immediately after the aircraft is in spot and tied down. Ejector/jettison cartridges may remain in the BRU-9/-10/-11/-32 ejector bomb rack provided the rack is electrically disconnected and either the mechanical safety pin is installed or the IFOBRL mechanism is locked.
6. The M61A1 gun ammunition is exempt from downloading requirements for up aircraft temporarily spotted in the hangar decks and aircraft undergoing limited maintenance; that is, turnaround maintenance, providing compliance with all gun dearm procedures of the airborne weapon/store loading manual, associated checklists, and store reliability card has been accomplished.
7. Guidance provided in the appendix is subjected to individual aircraft tactical manual limitations.
8. Maintenance on loaded aircraft (see Chapter 6 of this manual) applies.
9. Sonobuoy chutes P-2 shall be downloaded immediately after aircraft is in spot and tied down.
10. Impulse cartridges must be removed for LUU-2 and dispenser with LUU-2.
11. Strikedown/download of aircraft with jammed 20-mm/25-mm guns and gun pods is prohibited.
12. If an ITL signal has been initiated for a Harpoon/SLAM/JSOW weapon, that weapon shall be treated as a hung weapon during recovery, downloading, and strikedown aboard ship.
13. An aircraft with ITL weapons aboard shall not be removed from the flight deck to the hangar deck until all ITL weapons have been downloaded.
14. When operationally feasible, aircraft shall be kept airborne for 35 minutes following an ITL abort/failure. Respot of an ITL aircraft is prohibited during peacetime operations until 2.5 hours have elapsed after the ITL abort/failure. Download prior to completion of the 2.5-hour waiting period is authorized provided that the missile is moved to a safe area on the flight deck with the nose oriented outboard over the deck edge.

WARNING

- Initiation of the ITL signal activates a battery within Harpoon/SLAM. With battery power available within the missile, electrical shorts occurring during aircraft recovery and/or while disconnecting the missile umbilical from the aircraft may actuate the missile engine/pyrotechnics. Battery voltage will remain sufficiently high to allow engine start for up to 35 minutes following ITL and to fire missile launch squibs within Harpoon/SLAM for up to 2.5 hours following ITL.
- Voltage in the JSOW will remain sufficiently high to allow wing deployment if the umbilical is disconnected.

15. Walleye II loaded on F/A-18 is nonrecoverable.

Index

	<i>Page No.</i>		<i>Page No.</i>
A			
Abort/Strikedown	6-14	Aqueous Film Forming Foam System and Mobile Firefighting Equipment	2-2
Additional Requirements	1-1	Arming	6-11
Advisory Control	3-2	Arrival	
AIR		Entering the Carrier Control Area	5-1
Officer	3-1	Information	5-1
Operations Officer	3-1	Procedures	5-1
Plan	2-1	B	
Transfer Officer	2-7	Basic Procedures	3-5
Air plan	2-1	Briefing	2-6, 6-1
Ordnance Load Plan	2-2	C	
Aircraft		Carrier Pattern Emergencies	5-24
Alone	5-14	Case I	5-1, 5-3
COD	5-2	and Case II	4-8
Control of Departing	4-5	COD Aircraft	5-2
Diversion of	5-27	Departure	4-7
Downed	4-3	Drag	5-2
Downed and Standby	4-3	Helicopters	5-2
Fixed-Wing	5-22, 5-23	Jet/Turboprop Aircraft Port Holding/ Spin Pattern	5-1
Fueling and Defueling	6-7	Landing Pattern Entry	5-2
Jet	4-7	Rendezvous	4-7
Jet/Turboprop	4-7	Upwind Turn	5-3
Launching Condition	4-4	Voice Reports	5-2
Maintenance on Loaded	6-13	ZIP LIP	5-2
Movement of	6-2	CASE I/II	5-24
Recovering Fixed-Wing	5-16	Conditions	4-4
Report of Damage to	6-6	Case II	4-7
Security	6-6	Departure	4-7
Standby	4-3	Case II/III Rendezvous	4-7
Turboprop	4-7	CASE III	5-3
All Aircraft Except Helicopters	5-13	Communication or NAVAID Failure	
All Personnel	1-2	During Approach	5-14
Approach		Conditions	4-4
ICLS	5-12	Delta Procedures	5-13
Minimums	5-5	Departing Marshal	5-5
Nonprecision	5-12	Departure	4-7, 4-8
PALS Mode III	5-12	Departure Voice Reports	4-6
Approach and Landing	5-17	Frequency/IFF/SIF Changes	5-5
Approaches	5-4		
En Route Radar	5-4		

	<i>Page No.</i>		<i>Page No.</i>
General Instructions	5-4	Helicopter Departure	4-8
Instrument Approach Procedures	5-5	Control of Radio Circuits	3-4
Marshal Instructions	5-4	Correcting to the Final Bearing	5-5
Initial Separation	5-5	Criteria	3-2
Marshal Procedures	5-3	Control	3-2
Missed Approach/Waveoff/Bolter	5-12	Rescue Helicopter Launching	4-2
Night EMCON Recovery	5-13	Separation	3-3
Voice Communication Procedures	5-15		
Radar Handoff Procedures	5-15	D	
CATCC	3-4	Day Communication Emergencies	5-24
CDC	3-4	Dearming	6-12
Changes in Pilot or Aircraft Assignments	2-7	Degrees of Control	3-2
Close Proximity Operations	2-6	Delta Procedures	5-13
COD Aircraft	5-2	Departing Marshal	5-5
Combat Direction Center Officer	3-1	Departure	4-6
Communication	3-4	Communication Procedures	4-6
Control	3-4	Radials	4-5
Control of Radio Circuits	3-4	Diversion of Aircraft	5-27
or NAVAID Failure During Approach	5-14	Downed	4-3
Recording of Radio Circuits	3-4	Aircraft	4-3
Security	3-4	Standby Aircraft	4-3
Voice Procedures	3-4	Drag	5-2
Compulsory Arrival, Marshal, and Approach Voice Reports	5-15	E	
Condition	4-4	Electronic Emission Control	3-3
I	4-4	Elevator Operation	6-5
II	4-4, 4-5	Emergency	
III	4-4, 4-5	Basic Procedures	3-5
IV	4-4, 4-5	Control Procedures	3-4
Control		Fixed-Wing Aircraft	5-23
Advisory	3-2	Helicopters	5-23
Authority	3-5	Initial Control Responsibility	3-4
Communication	3-4	Landing	5-23
Control criteria	3-2	Marshal Fixes	5-3
Degrees of Control	3-2	Procedures	6-14
Electronic Emission	3-3	Emergency after Launch	4-4
Fuel Transfer and Dump	5-25	Case I/II Conditions	4-4
Monitor	3-2	Case III Conditions	4-4
Nonradar	3-2	Emergency Signals	5-24
Positive	3-2	Carrier Pattern Emergencies	5-24
Control of Departing Aircraft	4-5	Day Communication Emergencies	5-24
Departure Communication Procedures	4-6	Night Communication Emergencies	5-24
Departure Radials	4-5	Visual Signals to Aircraft From Ship Under EMCON or Lost Communication Conditions	5-24
Fixed-Wing Departures/Rendezvous	4-7		

	<i>Page No.</i>
Visual Signals to Ship From Aircraft With Radio Failure	5-24
En Route Radar Approaches	5-4
Entering the Carrier Control Area	5-1
Entry	5-2
Landing Pattern	5-2
EQUIPMENT	6-2

F

Failure	5-24
Visual Signals to Ship From Aircraft With Radio	5-24
Failure of Carrier Navigation Aids/CATCC Radars Prior to Approach	5-15
Fixed Wing	4-4
Departures/Rendezvous	4-7
Aircraft	5-22, 5-23
IMC at Altitude	4-8
Flight	2-2
Aqueous Film Forming Foam System and Mobile Firefighting Equipment	2-2
Close Proximity Operations	2-6
Crewmembers	1-2
Plans and Advisories	2-6
Preliminary Procedures - Air Officer	2-5
Preliminary Procedures - CATCC	2-2
Quarter Stations	2-2
Frequency/IFF/SIF Changes	5-5
Fuel Transfer and Dump Control	5-25
Fueling and Defueling	6-7
Fueling and Defueling Aircraft	6-7
Fueling and Defueling	6-7
Hot Refueling	6-7

G

General	
Instructions	5-4
Requirements	6-1
Good Azimuth and	4-6
Good DME	4-6
No DME	4-6

H

Helicopter	4-8
Departure	4-8
Launch Procedures	4-1
Safety Precautions	4-2
Helicopter Departure	4-8
Helicopters	4-4, 5-2, 5-3, 5-13, 5-23, 5-24
Hot Refueling	6-7
Hung/Unexpended Weapons	6-12

I

ICLS Approach	5-12
ILARTS Special Events Coverage	6-6
Initial	3-4, 5-5
Control Responsibility	3-4
Separation	5-5
Instrument Approach Procedures	5-5
Intent to Launch Weapons	6-11

J

Jet Aircraft	4-7
Jet/Turboprop Aircraft	4-7, 5-3
Port Holding/Spin Pattern	5-1

L

Landing	3-1, 5-17
Approach and	5-17
Emergency	5-23
Signal Officer	3-1
Signalman Enlisted	3-1
Special Procedures for Carrier Qualification	5-22
Landing Pattern Entry	5-2
Lateral Separation	3-3
Launch Frequencies	4-6
Launching	4-4
Condition Aircraft	4-4
Fixed Wing	4-4
Helicopter Launch Procedures	4-1
Helicopter Safety Precautions	4-2
Helicopters	4-1, 4-4
Rescue Helicopter Launching Criteria	4-2

	<i>Page No.</i>
Lost Communications During Departures	4-6

M

Maintenance	6-1
Liaison	6-1
on Loaded Aircraft	6-13
Personnel	1-2
Marshal	5-4
Airspeed	5-4
Altitude Assignment	5-4
Altitude Separation	5-4
Instructions	5-4
Procedures	5-3
Missed Approach/Waveoff/Bolter	5-12
Monitor	5-10
PALS Mode I Approach (With AN/ARA-63/AN/ARN-138)	5-10
Monitor Control	3-2
Movement of Aircraft	6-2
Aircraft Security	6-6
Elevator Operation	6-5
ILARTS Special Events Coverage	6-6
Report of Damage to Aircraft	6-6

N

Night	5-24
Communication Emergencies	5-24
EMCON Recovery	5-13
Nonprecision Approach	5-12
Nonradar Control	3-2

O

Operation	6-5
Elevator	6-5
Operations	
Close Proximity	2-6
Officer	3-1
Tanker	5-24
Ordnance Load Plan	2-2
Ordnance Personnel	1-2
Overhead Marshal	5-4

P

PALS Mode	5-10
I Approach (With AN/ARA-63/AN/ARN-138 Monitor)	5-10
IA Approach (ILM Not Required)	5-11
II Approach (ILM Not Required)	5-11
IID Approach (ILM Not Required)	5-12
III Approach	5-12
Passenger Transfers	2-7
Penetration/Approach	5-5
Phraseology	5-16
Pilots	3-1
Plane	
Captains	1-2
Control Authority	3-5
Guard Helicopter	3-5
Plane Guard Station	3-5
Restrictions	3-5
Search and Rescue	3-5
Positive Control	3-2
Predeployment Lecture Syllabus	1-2
All Personnel	1-2
Flight Crewmembers	1-2
Maintenance Personnel	1-2
Ordnance Personnel	1-2
Plane Captains	1-2
Preliminary Procedures - Air Officer	2-5
Preliminary Procedures - CATCC	2-2
Preparation for Recovery	5-16
PriFly	3-4
Procedures	
Arrival	5-1
Basic	3-5
Delta	5-13
Departure Communication	4-6
Emergency	6-14
Emergency Control	3-4
Helicopter Launch	4-1
Instrument Approach	5-5
Radar Handoff	5-15
Recovery	5-19
Voice	3-4
Weapon Handling	6-8

	<i>Page No.</i>		<i>Page No.</i>
R			
Radar Handoff Procedures	5-15	Lateral Separation	3-3
Recording of Radio Circuits	3-4	Vertical Separation	3-3
Recovering	5-16	Single-Frequency Departures	4-6
Approach and Landing	5-17	Special Procedures for Carrier	
Fixed-Wing Aircraft	5-16	Qualification Landing	5-22
Helicopters	5-19	Fixed-Wing Aircraft	5-22
Special Safety Precautions	5-17	Helicopters	5-23
Recovery Procedures	5-19	Special Safety Precautions	5-17, 5-21
(Case III)	5-25	Standby Aircraft	4-3
Special Safety Precautions	5-21	Station	3-5
Tanker Procedures	5-24	Plane Guard	3-5
Tanking Pattern	5-25	Stations	2-2
Rendezvous	5-25	Flight Quarter	2-2
High/On Top (Day and Night)	5-25	T	
Low (Day and Night)	5-24	Tanker Operations	5-24
Procedures	5-24	Fuel Transfer and Dump Control	5-25
Report of Damage to Aircraft	6-6	Recovery (Case III)	5-25
Requirements	1-1, 6-1	Recovery Tanker Procedures	5-24
Additional	1-1	Recovery Tanking Pattern	5-25
General	6-1	Rendezvous Procedures	5-24
Training	1-1	Training Requirements	1-1
Rescue Helicopter	4-3	Transient Helicopters	5-1
Information	4-3	Turboprop Aircraft	4-7
Launching Criteria	4-2	U	
Rescue Helicopter Launching Criteria	4-2	Upwind Turn	5-3
Responsibilities	3-1	V	
Air Officer	3-1	Vertical	6-6
Air Operations Officer	3-1	Replenishment	6-6
Combat Direction Center Officer	3-1	Separation	3-3
Landing Signal Officer	3-1	Visual Signals	
Landing Signalman Enlisted	3-1	to Aircraft From Ship Under EMCON	
Operations Officer	3-1	or Lost Communication Conditions	5-24
Pilots	3-1	to Ship From Aircraft With Radio Failure ..	5-24
Respot Forward	4-3	Voice	3-4, 5-15
Restrictions	3-5	Communication Procedures	5-15
S			
Search and Rescue	3-5	Procedures	3-4
Separation Criteria	3-3	Reports	5-2

	<i>Page No.</i>		<i>Page No.</i>
W			
Weapon	6-9	Hung/Unexpended Weapons	6-12
Arming	6-11	Intent to Launch Weapons	6-11
Darming	6-12	Loading/Downloading	6-9
Definitions	6-8	Maintenance on Loaded Aircraft	6-13
Emergency Procedures	6-14	Movement	6-9
Handling Procedures	6-8	Z	
		ZIP LIP	5-2

LIST OF EFFECTIVE PAGES

Effective Pages	Page Numbers
Original	1 (Reverse Blank)
Original	3 (Reverse Blank)
Original	5 (Reverse Blank)
Original	7 (Reverse Blank)
Original	9 (Reverse Blank)
Original	11 thru 16
Original	17 (Reverse Blank)
Original	19 thru 23 (Reverse Blank)
Original	25 thru 29 (Reverse Blank)
Original	1-1 thru 1-2
Original	2-1 thru 2-7 (Reverse Blank)
Original	3-1 thru 3-9 (Reverse Blank)
Original	4-1 thru 4-22
Original	5-1 thru 5-33 (Reverse Blank)
Original	6-1 thru 6-14
Original	A-1 (Reverse Blank)
Original	B-1 (Reverse Blank)
Original	C-1 thru C-2
Original	Index-1 thru Index-6
Original	LEP-1 (Reverse Blank)

