

***ARMY TM 9-1010-223-10
MARINE CORPS TM 08206A-10/1A**

OPERATOR'S MANUAL

**LIGHTWEIGHT
COMPANY MORTAR
60MM, M224
(NSN 1010-01-020-5626)**

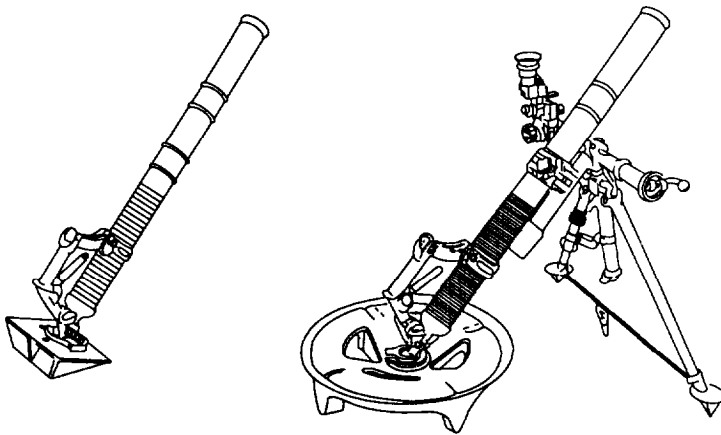

***SUPERSEDEURE NOTICE.** Supersedes copy dated 18 December 1987.

DISTRIBUTION STATEMENT C. Distribution authorized to U.S. Government agencies and their contractors. This publication is required for administration and operational purposes, as determined 16 September 1994. **ARMY:** Other requests for this document will be referred to Director Armament and Chemical Acquisition and Logistics Activity, ATTN: AMSTA-AC-NML, Rock Island, IL 61299-7630. **MARINE CORPS:** Requests for this document must be referred to: Commandant of the Marine Corps (ARD), Washington, D.C. 20380-0001.

DESTRUCTION NOTICE. Destroy by any method that will prevent disclosure of contents or reconstruction of the document.

**HEADQUARTERS, DEPARTMENT OF THE ARMY
HEADQUARTERS, UNITED STATES MARINE CORPS
15 SEPTEMBER 1998**

PCN18408206100

WARNING SUMMARY

RADIATION HAZARD



This item contains radioactive material. Control of this radioactive material is mandated by Federal law. Immediately report any suspected lost or damaged items to your Radiation Protection Officer. If your Radiation Protection Officer cannot be reached, contact the TACOM-ACALA safety office during regular duty hours; or call the Rock Island Police office at DSN 793-6135 after duty hours.

A. *RULES and REGULATIONS*: Copies of the following rules and regulations are maintained at ACALA, Rock Island, IL 61299-7630. Copies may be requested or information obtained by contacting the ACALA Radiation Protection Officer (RPO), DSN 793-2962/2965, Commercial (309) 782-2962/2965.

- (1) 10CFR Part 19 - Notices, Instructions and Reports to Workers; Inspections.
- (2) 10CFR Part 20 - Standards for Protection against Radiation.
- (3) 10CFR Part 21- Reporting of Defects and Noncompliance.
- (4) NRC license, license conditions, and license application.

B. *SAFETY PRECAUTIONS*: The radioactive material used in these instruments is tritium gas (H_3) sealed in glass vials. These sources illuminate the instrumentation for night operations. Tampering with or removal of the sources in the field is prohibited by Federal law. In the event there is no illumination, notify the local RPO or ACALA RPO. If skin contact is made with any area contaminated with tritium, wash immediately with soap and water.

The beta radiation emitted by tritium is a hazard only if the vial or source is broken. Tritium can be taken into the body by inhalation, ingestion, or skin absorption/injection. If the vial is broken, the tritium gas will dissipate into the surrounding air. If released in a confined space such as a storage locker, container, unventilated room, or military vehicle, tritium is absorbed by lungs from air or by skin contact with contaminated surfaces. However, the body naturally eliminates absorbed tritium.

C. *IDENTIFICATION*: Instruments containing radioactive self-luminous vials are identified by means of radioactive warning labels (see page a). These labels should not be defaced or removed and should be replaced immediately when necessary (item 11, WP 0023 00). Refer to the local RPO or the ACALA RPO for instructions on handling, storage, or disposal.

D. *STORAGE*: Spare equipment must be stored in the shipping container, as received, until installed on the weapon. Storage of these items is recommended to be in an outdoor shed-type storage or unoccupied building.

WARNING SUMMARY- Continued

E. *SHIPPING*: All radioactively illuminated instruments will be evacuated to the appropriate echelon for inspection and repair. Non-illuminated instruments will be disposed of as radioactive waste. Contact installation Radiation Protection Officer.

F. *EMERGENCY PROCEDURES*: If a source breaks or is not illuminated, follow "SWIMN":

Stop - and think.

Warn - nearby personnel of situation to avoid additional exposure. Immediately open doors/hatches if exiting room/vehicle/area is not possible. If exiting, move upwind for 15 minutes.

Isolate - Do not handle broken tritium devices with bare hands. Use gloves (if available) or a bag. Quickly place item in plastic bag (item 2, WP 0023 00) (or, if bag not immediately available, wrap in plastic) and, if possible, leave area.

Minimize - wash hands.

Notify - call the Radiation Protection Officer (RPO).

G. *SPECIAL HANDLING*: Radioactive material is used in the M56/M59 aiming post lights, range indicator assembly, and M64 series sight units. Radiation leakage may occur if broken or damaged. If exposed to a broken or damaged instrument, see medical personnel.

GENERAL

Loading a mortar weapon with two men (alternately) can be very dangerous and could prove fatal. Even with one-man loading, double loading can occur. This is especially true in rapid fire exercises. For this reason, it is imperative that there be absolute certainty that the previous round left the mortar tube before a new round is dropped in.

Firing site must have mask clearance and no overhead obstructions.

Firing over the heads of unprotected troops is prohibited per AR 385-63.

When firing during training, the minimum horizontal range is 300 meters.

In hand-held mode, place baseplate against solid object when:

1. Firing at range more than 300 meters for charge zero.
2. Firing at ranges of more than 950 meters for charge one.

In hand-held mode DO NOT fire with any charge greater than the following:

1. M720/M888 cartridge: charge one
2. M49A4 cartridge: charge three
3. M83 series cartridge: charge two
4. M302A1 cartridge: charge two

WARNING SUMMARY - Continued

All personnel within fifty meters of the muzzle during firing must use single hearing protection.

Adequate fragmentation cover will be taken when firing cartridges for distances less than 300 meters. During training, cartridges will be fired a minimum distance of 300 meters.

Firing temperature limits for M720 and M888 cartridges are - 50°F to + 145°F. Temperature limits for all other cartridges are - 40°F to +125°F.

Do not fire unpacked ammunition which has been dropped, or packaged ammunition which has been dropped from a height greater than one meter. These cartridges will be returned to Ammunition Supply Point (ASP) as unserviceable.

Selector should be at S (safe) except when firing.

Misalignment of safe detent position on firing selector will cause a malfunction, which may accidentally arm the mortar and can cause an unintentional discharge of round. Injury or death may occur.

Trigger firing with an unseated baseplate in the conventional mode is prohibited.

Trigger fire only at charge 0 or 1, with either baseplate.

Propelling charges are not interchangeable. Do not substitute one model for another. Do not mix lots.

Propelling charge increments should be positioned as close to fin as possible to avoid a short round.

Short rounds may occur if an excessive amount of oil or water is in barrel during firing.

If using M525 or M527 Point Detonating (PD) fuzes, see inspections and warnings on pages WP 0024 00-7 and WP 0024 00-8.

M525 and M527 PD fuzes. Do not fire cartridges if fuze makes a buzzing sound when removing safety pins. Check fuze for presence of bore-riding pin after removing safety pin. Do not fire cartridge if bore-riding pin is missing. Notify Explosive Ordnance Disposal (EOD).

If misfire occurs with an unseated baseplate in the conventional mode, do not attempt to trigger fire the mortar. Place selector lever on S and proceed with the remainder of the misfire procedure in this manual.

Do not look into cannon or try to force a cartridge down the bore.

WARNING SUMMARY - Continued

Never attempt to remove a misfired round from a hot cannon.

Never stand behind or in front of the tube; stand on either side.

After lifting mortar out of baseplate, never allow breech cap end of cannon tube to go below horizontal position until the round is removed.

Never put hands in front of the muzzle.

Paint thinners are flammable and toxic. Do not use near an open flame. Use only in a well ventilated area.

FIRST AID

For information on first aid, see FM 21-11.

ACCIDENTS AND MALFUNCTION REPORTS (Marine Corps Only)

Accidents involving injury to personnel or damage to the equipment will be reported in accordance with current edition of MCO P5102.1_ (Ground Mishaps Report).

LIST OF EFFECTIVE PAGES / WORK PACKAGES

Date of issue for original pages /work packages is:

Original 0... Sept 98

TOTAL NUMBER OF PAGES FOR FRONT AND REAR MATTER IS 14 AND TOTAL NUMBER OF WORK PACKAGES IS 25 CONSISTING OF THE FOLLOWING:

Page / WP No.	*Revision No.	Page / WP No.	*Revision No.
Cover	0	1 - 3/4 blank (Index) . . .	0
A-d	0		
A/B blank	0		
i - ii	0		
WP 000100 - 0025 00	0		

* Zero in this column indicates an original page or work package.

TM 9-1010-223-10

*ARMY TM 9-1010-223-10
MARINE CORPS TM 08206-10/1A

HEADQUARTERS, DEPARTMENT OF THE ARMY
HEADQUARTERS, UNITED STATES MARINE CORPS
Washington D.C., 15 September 1998

OPERATOR'S MANUAL
LIGHTWEIGHT COMPANY MORTAR
60MM, M224
(NSN 1010-01-020-5626)

REPORTING ERRORS AND RECOMMENDING IMPROVEMENTS

You can help improve this manual. If you find any mistakes or if you know of a way to improve the procedures, please let us know. Mail your letter or DA Form 2028 (Recommended Changes to Publications and Blank Forms) direct to: Director, Armament and Chemical Acquisition and Logistics Activity, ATTN: AMSTA-AC-NML, Rock Island, IL 61299-7630. You may also send in your recommended changes via electronic mail or by fax. Our fax number is DSN 793-0726, Commercial (309) 782-0726. Our e-mail address is AMSTA-AC-NML@ria.army.mil). A reply will be furnished to you.

Marine Corps users submit NAVMC 10772 to: Commander, Marine Corps Logistics Bases (Code 850), 814 Radford Blvd, Albany, GA 31704-1128. Recommended changes may be sent by fax (DSN 567-6439, Commercial (912) 439-6439), by e-mail (COMMARCORLOGBASES_853SMB@ILS853@MCLB ALBANY) (provide information normally on NAVMC 10772), or by naval message (in any format, only one publication per message). A reply will be furnished to you. Marine Corps users/maintainers should also provide an informational copy to: Commander, Marine Corps System Command, ATTN: CBGI, 2033 Barnett Ave, Suite 315, Quantico, VA 22314-5010.

DISTRIBUTION STATEMENT C. Distribution authorized to U.S. Government agencies and their contractors. This publication is required for administration and operational purposes, as determined 16 September 1994. **ARMY:** Other requests for this document will be referred to Director, Armament and Chemical Acquisition and Logistics Activity, ATTN: AMSTA-AC-NML, Rock Island, IL 61299-7630. **MARINE CORPS:** Requests for this document must be referred to: Commandant of the Marine Corps (ARD), Washington, D.C. 20380-0001.

DESTRUCTION NOTICE. Destroy by any method that will prevent disclosure of contents or reconstruction of the document.

*This manual supersedes TM 9-1010-223-10 dated 18 December 1987, including all changes.

TABLE OF CONTENTS

WP Sequence No.

WARNING SUMMARY

CHAPTER 1 - INTRODUCTORY INFORMATION WITH THEORY
OF OPERATION

General Information	0001 00
Equipment Description and Data	0002 00
Theory of Operation	0003 00

CHAPTER 2 - OPERATOR INSTRUCTIONS

Description and Use of Operator Controls and Indicators	0004 00
Assembly and Preparation for Firing - Conventional Mode	0005 00
Assembly and Preparation for Firing - Hand-held Mode	0006 00
Emplacing Aiming Posts for Indirect Fire	0007 00
Loading and Firing - Conventional Mode	0008 00
Loading and Firing - Hand-held Mode	0009 00
Misfire Procedure - Conventional Mode	0010 00
Misfire Procedure - Hand-held Mode	0011 00
Preparation for Movement - Conventional Mode	0012 00
Preparation for Movement - Hand-held Mode	0013 00
Operation under Unusual Conditions	0014 00

CHAPTER 3 - TROUBLESHOOTING PROCEDURES

Introduction	0015 00
Troubleshooting Procedures	0016 00

CHAPTER 4 - MAINTENANCE INSTRUCTIONS

Preventive Maintenance Checks and Services (PMCS), Including Lubrication Instructions	0017 00
60MM, M224 Lightweight Company Mortar Maintenance	0018 00
Care and Cleaning of Optical Parts	0019 00

CHAPTER 5 - SUPPORTING INFORMATION

References	0020 00
Components of End Item (COEI) and Basic Issue Items (BII) Lists	0021 00
Additional Authorization List (AAL)	0022 00
Expendable and Durable Items List	0023 00
Ammunition Marking Information	0024 00
Marine Corps Inventory Sheet (Marine Corps Only)	0025 00

INDEX

TM 9-1010-223-10

CHAPTER 1

**INTRODUCTORY INFORMATION
WITH
THEORY OF OPERATION**

SCOPE

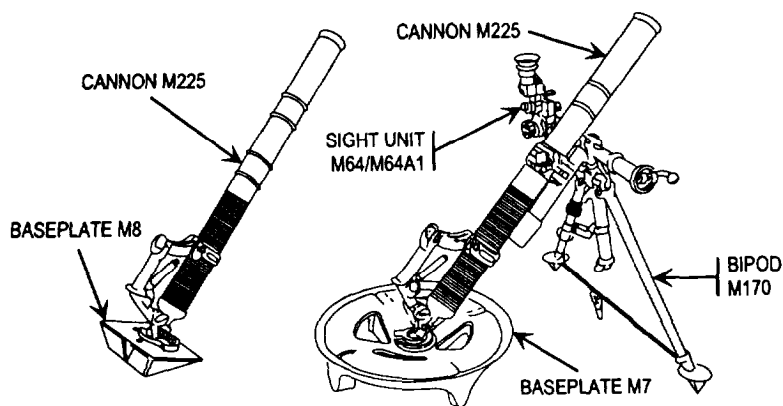
**60MM LIGHTWEIGHT COMPANY MORTAR, M224****Type of Manual**

Operator's.

Model Number and Equipment Name

60mm Lightweight Company Mortar, M224.

Purpose of Equipment

The M224 Mortar is used to provide high-angle fire for close-in support of ground troops.

MAINTENANCE FORMS, RECORDS, AND REPORTS

Department of the Army forms and procedures used for equipment maintenance will be those prescribed by DA PAM 738-750, The Army Maintenance Management System (TAMMS). Marine Corps personnel refer to the on-line MCPDS or Marine Corps Stocklist SL-1-2 Index of Technical Publications.

Marine Corps users/maintainers will use the forms, records, and procedures used for equipment maintenance as prescribed by TM 4700-15/1, Ground Equipment Record Procedures.

REPORTING EQUIPMENT IMPROVEMENT RECOMMENDATIONS (EIR)

Army: If your M224 mortar needs improvement, let us know. Send us an EIR. You, the user, are the only one who can tell us what you don't like about your equipment. Let us know why you don't like the design or performance. Put it on an SF 368 (Product Quality Deficiency Report). Mail it to us at Commander, US Army Armament Research, Development and Engineering Center, ATTN: AMSTA-AR-QAW-A (R)/Customer Feedback Center, Rock Island, IL 61299-7300 (FAX: DSN 793-6653, Commercial (309) 782-6653) (E-Mail: qawqdrs@ria.army.mil). We will send you a reply.

Marine Corps Users/Maintainers:

If the M224 Mortar has been damaged during shipment, if shipment is incomplete, if incorrect item is received, or if incorrect quantity of Marine Corps Supply System Responsibility (SSR), Marine Corps Collateral Material (CM), or Marine Corps Using Unit Responsibility (UUR) items are received, submit a Supply Discrepancy Report SF 364 in accordance with SECNAVINST 4355.18.

If your M224 Mortar has deficiencies in materiel or design or nonconforming conditions which limit or prohibit the item from fulfilling its intended purpose, submit a Product Quality Deficiency Report (PDQR) SF 368 in accordance with MCO 4855.10_, Product Quality Deficiency Report, and TM 4700-15/1_, Equipment Records Procedures. Mail it to: Commander (Code 808-1), Marine Corps Logistics Bases, 814 Radford Blvd, Albany, GA 31704-1128 (Telephone: DSN 567-5292/5482, Commercial (912) 439-5292/5482; FAX: DSN 567-5631, Commercial (912) 439-5631; E-Mail: mbp@ala.usmc.mil) or via Naval Message. A reply will be furnished to you.

If your M224 Mortar needs improvements which relate directly to savings in man-hours, materials, supplies, equipment, funding, or increased effectiveness in carrying out the programs or missions of your unit/command, U.S. Marine Corps units/commands refer to MCO 1650.17, USMC Military Incentives Award Program.

CORROSION PREVENTION AND CONTROL (CPC)

Corrosion Prevention and Control (CPC) of Army materiel is a continuing concern. It is important that any corrosion problems with this item be reported so that the problem can be corrected and improvements can be made to prevent the problem in future items.

While corrosion is typically associated with rusting of metals, it can also include deterioration of other materials, such as rubber and plastic. Unusual cracking, softening, swelling, or breaking of these materials may be a corrosion problem.

CORROSION PREVENTION AND CONTROL (CPC) - Continued

If a corrosion problem is identified, it can be reported using SF 368, Product Quality Deficiency Report, Use of key words such as “corrosion”, “rust”, “deterioration”, or “cracking” will ensure that the information is identified as a CPC problem.

The form should be submitted to:

Commander
U.S. Army Armament Research, Development and Engineering Center
ATTN: AMSTA-AR-QAW-A (R)/Customer Feedback Center
Rock Island, IL 61299-7630

FAX: DSN 793-6653, Commercial (309) 782-6653

E-Mail: qawqdrs@ria.army.mil.

DESTRUCTION OF MATERIEL TO PREVENT ENEMY USE

Procedures and materials used for the destruction of the 60mm mortar in order to prevent enemy use will be found in TM 750-244-7.

EQUIPMENT DESCRIPTION AND DATA

0002 00

EQUIPMENT CHARACTERISTICS, CAPABILITIES, AND FEATURES**Capabilities and Features**

- 1 Lightweight
- 2 Highly mobile
- 3 Easily maintained
- 4 Self-illuminated fire control
- 5 Hand-held firing possible
- 6 Smooth bore

Major Weapon System Components

- 1 M225 60mm Mortar Cannon
- 2 M170 60mm Mortar Bipod
- 3 M7 and M8 Baseplates
- 4 M64/M64A1 Sight Unit

LOCATION AND DESCRIPTION OF MAJOR COMPONENTS**WARNING**

Take care in handling mortar components which contain radioactive tritium H_3 . These components are the range indicator assembly, M64/M64A1 sight units, and M58/M59 aiming post lights. If damage occurs, refer to WARNING information in the front of this manual for special handling instructions.

LOCATION AND DESCRIPTION OF MAJOR COMPONENTS - Continued

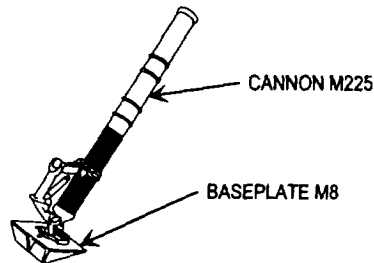

Cannon M225. Provides a lightweight, smooth bore cannon which incorporates a handle with a self-illuminating range indicator and a firing mechanism assembly.

Baseplate MS. This baseplate provides a firing base for the cannon in the hand-held mode.

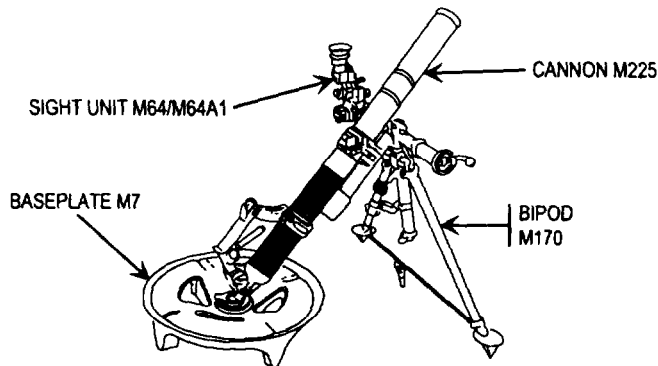

Cannon M225. Provides a lightweight, smooth bore cannon which incorporates a handle with a self-illuminating range indicator and a firing mechanism assembly.

Bipod M170. Clamps to the cannon for use with baseplate M7 to provide support in the conventional mode. Provides means to elevate, traverse, and cross-level the cannon as well as to absorb the shock of firing.

Baseplate M7. This baseplate provides a stable firing base and helps absorb the firing shock in the conventional mode.

Sight Unit M64/M64A1. This unit provides self-illuminating sighting capability for indirect fire in the conventional mode. This unit serves to lay the mortar for deflection and elevation.

DIFFERENCES BETWEEN MODES

The lightweight company mortar can be fired in two modes. Each mode requires different equipment and procedures.

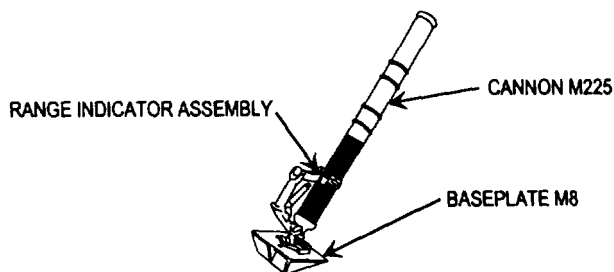
Hand-held Mode

1. No sight unit is used in this mode. The range indicator assembly is used to position cannon tube to estimated target range.
2. The M8 baseplate supports the cannon base. Further support is provided by a squad member since no bipod is used.

NOTE

The range indicator assembly on the M225 cannon was designed for the M720 round.

DIFFERENCES BETWEEN MODES - Continued

Conventional Mode

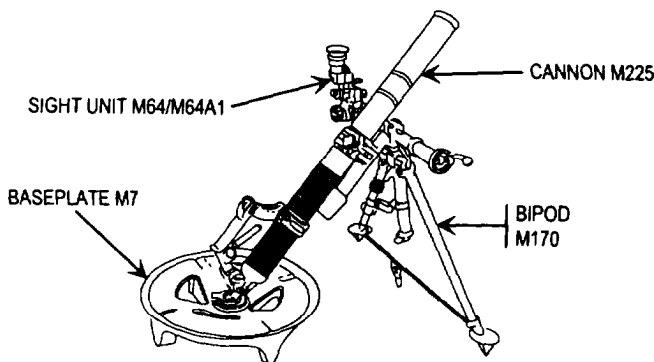

In this mode, the weapon functions as a conventional mortar. A sight unit is used to lay the mortar, and support is provided by a bipod and a baseplate (M7). The bipod also allows deflection, elevation changes, and cross-leveling.

EQUIPMENT DATA

RATE OF FIRE

M720 and M888 Cartridges	
Maximum	30 RPM (For 4 minutes)
Sustained	20 RPM
M49A4, M302A1, M83A3, and M69 Cartridges	
Maximum	30 RPM (For 1 minute) THEN 18 RPM (For the next 4 minutes)
Sustained	8 RPM

RANGE

Minimum	231 ft (70 m)
Maximum.....	11,517 ft (3490 m)

WEAPON ASSEMBLED

Weight, conventional mode	46.5 lb (21.1 kg)
Weight, hand-held mode	18 lb (8.2 kg)

EQUIPMENT DESCRIPTION AND DATA - Continued

0002 00

EQUIPMENT DATA - Continued

CANNON M225

Overall length 40 in. (1 m)
 Weight 14.4 lb (6.5 kg)

BIPOD M170

Weight 15.2 lb (6.9 kg)
 Overall length (collapsed) 28 in. (0.7 m)
 Azimuth adjustment 250 mils
 Elevation adjustment 800 to 1511 mils

BASEPLATE M7

Weight 14.4 lb (6.5 kg)

BASEPLATE M8

Weight 3.6 lb (1.6 kg)

SIGHT UNIT M64/M64A1

Weight 2.5 lb (1.1 kg)
 Field of View 302 mile (17 degrees)
 Magnification 1.5x unity power
 Illumination Self-contained radio-
 active tritium, 4 to 6
 years life

DROP FIRE METHOD

1. Mortar is fired by dropping the round (1) down the cannon tube (2), fin first. The selector switch (3) must be at D.

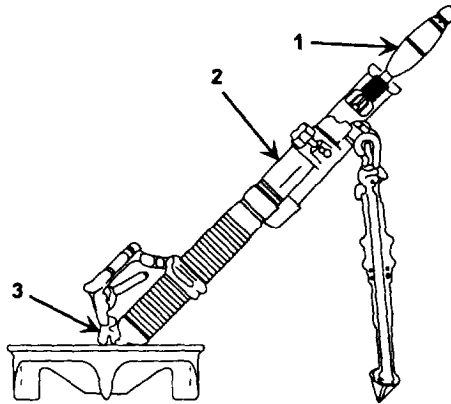

2. Percussion primer and ignition cartridge (4) function after the primer on round strikes firing pin (5) in base of cannon.

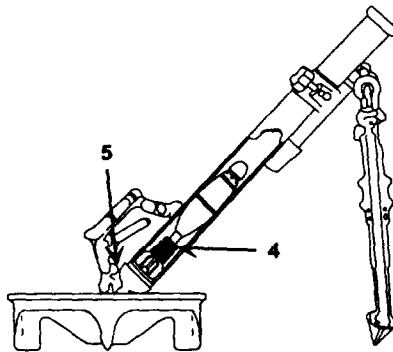

DROP FIRE METHOD - Continued

3. The propelling charge is ignited by the flash of the ignition cartridge. Expanding gases (6) force the round from the mortar.

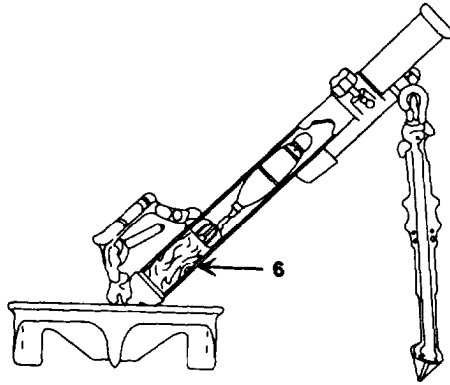

4. The fins (7) on the rear of the round stabilize it in flight.

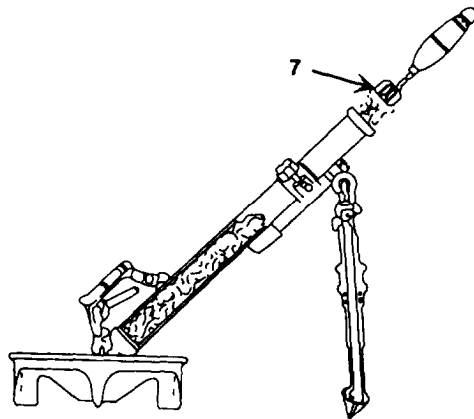

TRIGGER FIRE METHOD

CAUTION

Trigger firing without a round in the barrel will cause rapid failure of the sear. Trigger firing without a round should be limited to inspection for operation only.

1. With the selector switch (1) at T, the round (2) is dropped down the cannon tube (3), fin first. Mortar will fire only after trigger (4) is squeezed.
2. Trigger fire method can be used when the mortar is in either the conventional or hand-held mode.

TM 9-1010-223-10

CHAPTER 2
OPERATOR INSTRUCTIONS

BIPOD M170

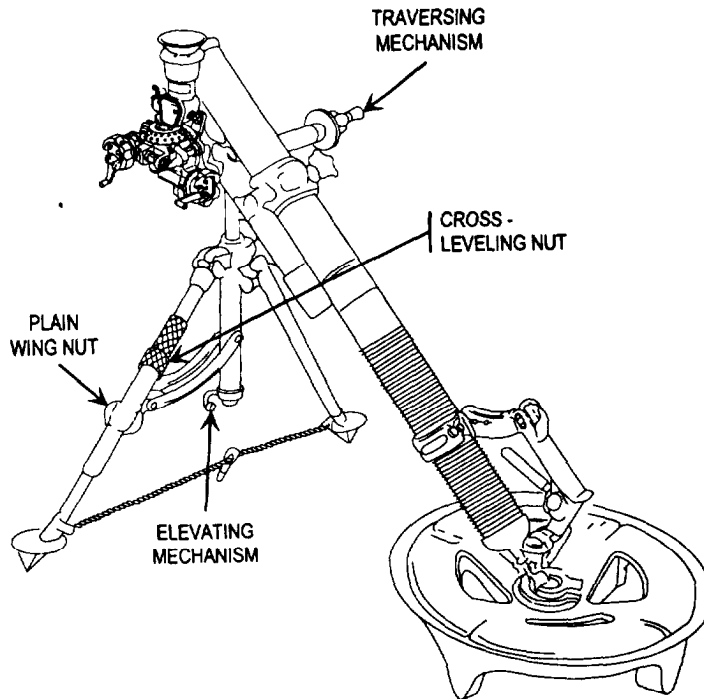

Cross-Leveling Nut. Removes minor cant of weapon.

Traversing Mechanism. Makes fine adjustment in deflection (azimuth).

Elevating Mechanism. Elevates or depresses mortar.

Plain Wing Nut. Removes major cant of weapon.

**DESCRIPTION AND USE OF OPERATOR CONTROLS
AND INDICATORS - Continued**

0004 00

CANNON M225

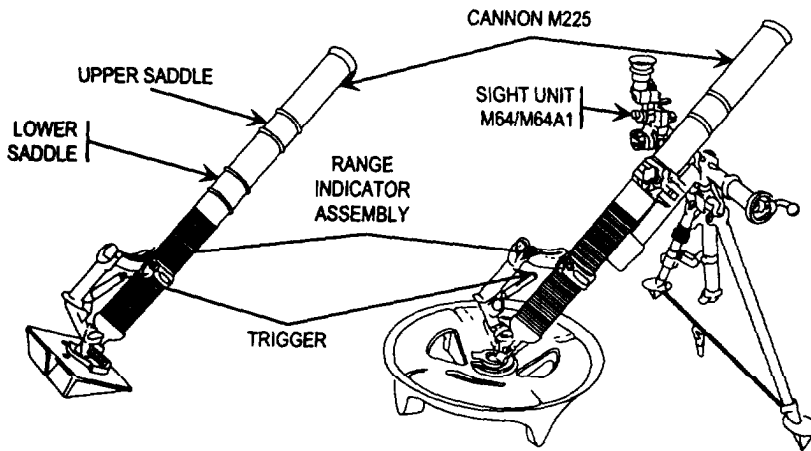

Lower Saddle. Bipod is attached here for elevations from 1101 to 1511 mils.

Upper Saddle. Bipod is attached here for elevations from 0800 to 1100 mils.

Sight Unit M64/M64A1. Lays weapon in elevation and deflection (azimuth).

Range Indicator Assembly. Indicates angle of cannon tube for hand-held firing.

Trigger. Activates mechanism to discharge the weapon.

**DESCRIPTION AND USE OF OPERATOR CONTROLS
AND INDICATORS - Continued**

0004 00

CANNON M225 - Continued

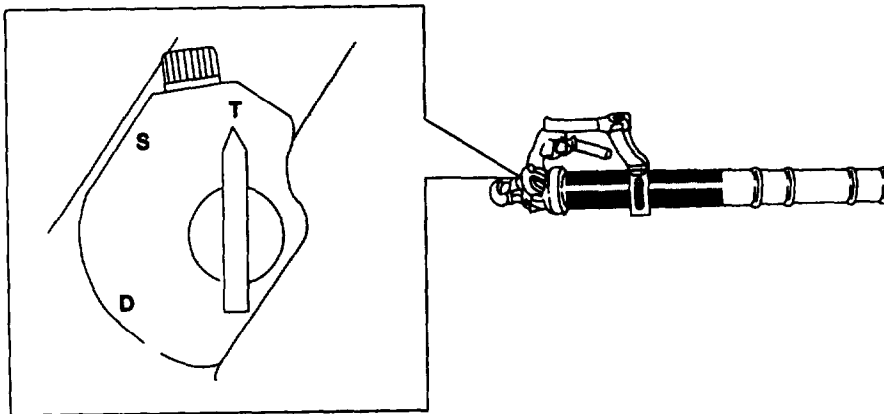

CAUTION

Trigger firing without a round in the barrel will cause rapid failure of the sear. Trigger firing without a round should be limited to inspection for operation only.

Firing Selector. Positions firing pin location for different firing modes or for safe.

D = DROP FIRE. Round fires when dropped.

S = SAFE. Mortar will not fire.

T = TRIGGER FIRE. Round fires only when trigger is squeezed.

DESCRIPTION AND USE OF OPERATOR CONTROLS
AND INDICATORS - Continued

0004 00

SIGHT UNIT M64/M64A1

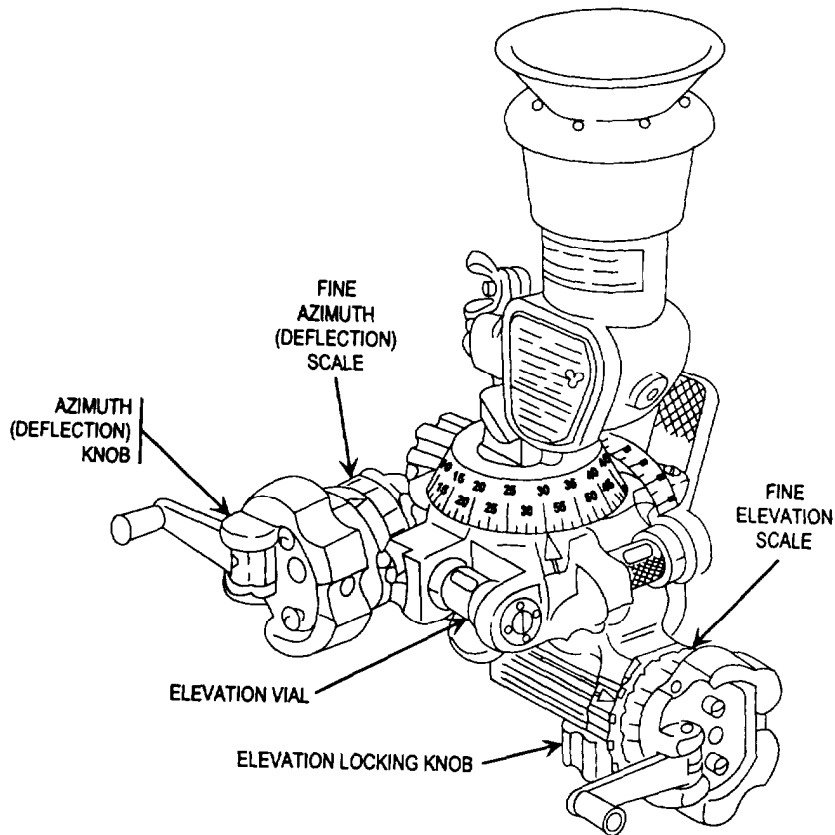

Fine Azimuth (Deflection) Scale. Indicates from 0 to 100 mils in 1 mil increments.

Fine Elevation Scale. Indicates from 0 to 100 mils in 1 mil increments.

Elevation Locking Knob. Unlocks or locks elevation mechanism and scales.

Elevation Vial. Indicates level condition of sight unit.

Azimuth (Deflection) Knob. Rotates deflection mechanism and scales.

DESCRIPTION AND USE OF OPERATOR CONTROLS
AND INDICATORS - Continued

0004 00

SIGHT UNIT M64/M64A1 - Continued

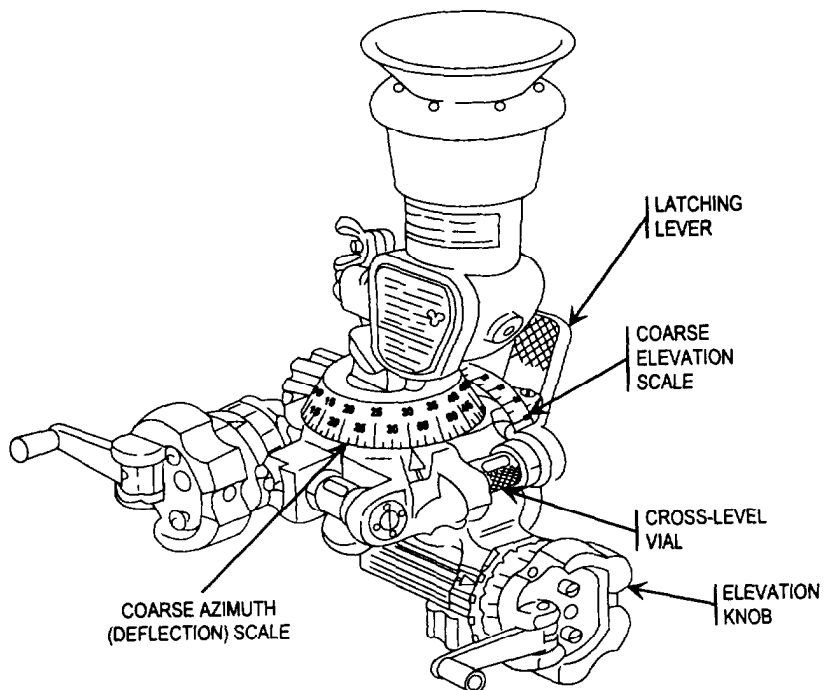

Latching Lever. Locks the sight unit to the bipod.

Coarse Elevation Scale. Indicates from 700 to 1600 mils in 100 mil increments.

Cross-Level Vial. Indicates level condition of sight unit.

Elevation Knob. Rotates elevation mechanism and scale.

Coarse Azimuth (Deflection) Scale. Indicates from 0 to 6400 mils in 100 mil increments.

DESCRIPTION AND USE OF OPERATOR CONTROLS
AND INDICATORS - Continued

0004 00

SIGHT UNIT M64/M64A1 - Continued

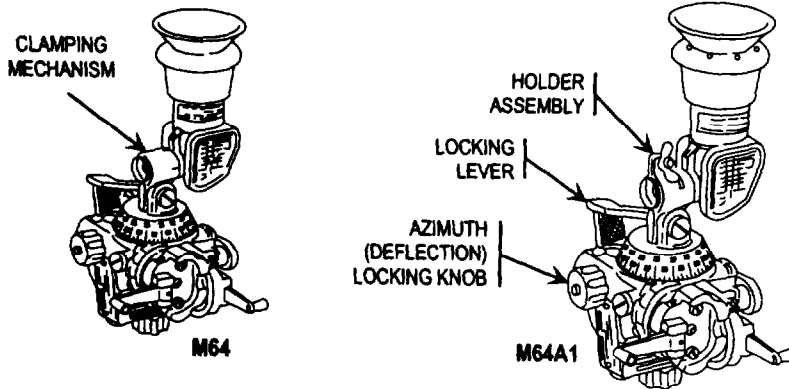

Clamping Mechanism (M64). Used to adjust and hold elbow telescope M64.

Locking Lever. Locks holder assembly and clamping mechanism in upright position.

Holder Assembly (M64A1). Used to adjust and hold elbow telescope on M64A1.

Azimuth (Deflection) Locking Knob. Unlocks or locks deflection mechanism.

THIS WORK PACKAGE COVERS:

Emplacement of Mortar, Installation of M64/M64A1 Sight Unit, Boresighting

INITIAL SETUP:

Maintenance Level

Operator

Materials/Parts

- Flat-tip screwdriver (item 13, Basic Issue Items, WP 0021 00)
- Gun muzzle cover (item 5, Basic Issue Items, WP 0021 00)
- Sight unit case (item 3, Basic Issue Items, WP 0021 00)
- Wiping rag (item 16, WP 0023 00)

References

- AR 385-63
 - FM 23-90
-

EMPLACEMENT OF MORTAR

WARNING

Firing site must have mask clearance and no overhead obstructions.

Firing over the heads of unprotected troops is prohibited per AB 385-63.

When tiring during training, the minimum horizontal range is 300 meters.

1. Select firing site (preferably a flat area with firm soil) with a line of fire clear of unauthorized personnel. Emplace M7 baseplate (1) by standing on it and rocking.

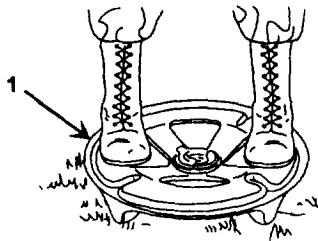

ASSEMBLY AND PREPARATION FOR FIRING - CONVENTIONAL MODE
- Continued

0005 00

EMPLACEMENT OF MORTAR - Continued

2. Rotate locking cap (2) until opening in cap points in direction of fire. Place base of cannon (3) into locking cap opening (4).

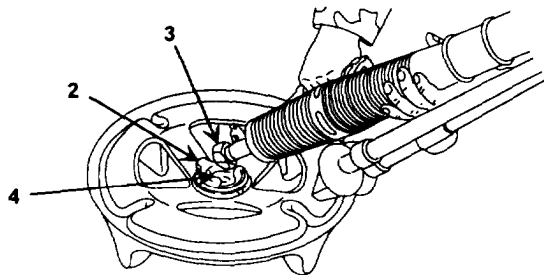

3. Rotate cannon (3) 1/4 turn to firing position with handle and firing mechanism (5) upward.

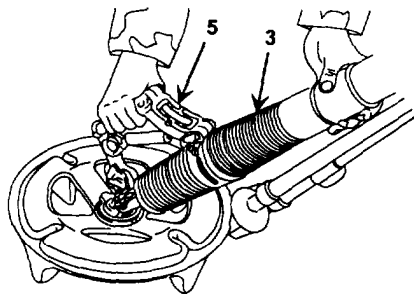

4. Loosen knob (6) and swing it downward. Open collar (7).
5. Place upper saddle (8) or lower saddle (9) in collar (7) with handle and firing mechanism straight-up on top of cannon. Use upper saddle for elevations of 1100 mils or less and use lower saddle for elevations greater than 1100 mils. Upper saddle must be used for boresighting.

ASSEMBLY AND PREPARATION FOR FIRING - CONVENTIONAL MODE
- Continued

0005 00

EMPLACEMENT OF MORTAR - Continued

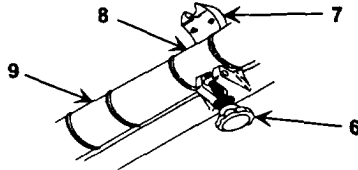

6. Close collar (7) and swing knob (6) into place and tighten.

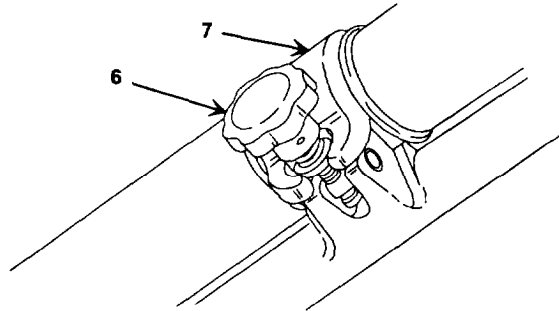

7. Push up legs (10) to unlatch and swing out.

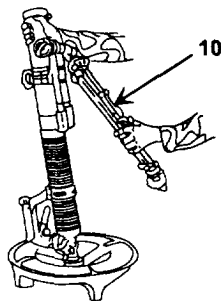

ASSEMBLY AND PREPARATION FOR FIRING - CONVENTIONAL MODE
- Continued

0005 00

EMPLACEMENT OF MORTAR - Continued

8. Unfasten snap hook (11) and wire rope assembly (12). Loosen plain wing nut (13) and spread legs.
9. If bipod is attached to upper saddle, set feet (14) about 1 1/2 ft (0.46 m) in front of baseplate. If bipod is attached to lower saddle, set feet about 1 ft (0.31 m) in front of baseplate. Press feet firmly into ground.

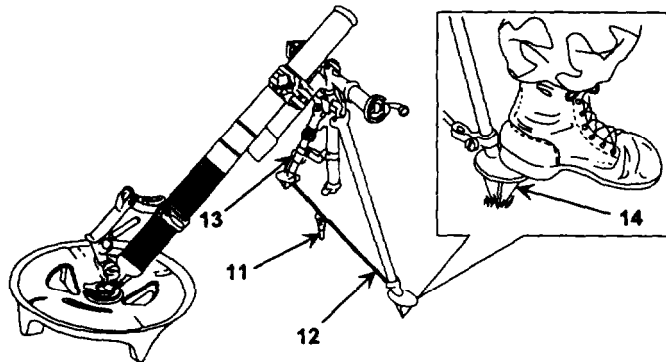

10. With plain wing nut (13) still loose, adjust cross-leveling mechanism until elevating mechanism (15) is near vertical. Hand tighten plain wing nut.

NOTE

Cross-leveling removes cant from weapon.

11. Adjust cross-leveling nut (16) clockwise to move the elevating mechanism (15) to the left or counterclockwise to move the elevating mechanism to the right until it is vertical.

ASSEMBLY AND PREPARATION FOR FIRING - CONVENTIONAL MODE
- Continued

0005 00

EMPLACEMENT OF MORTAR - Continued

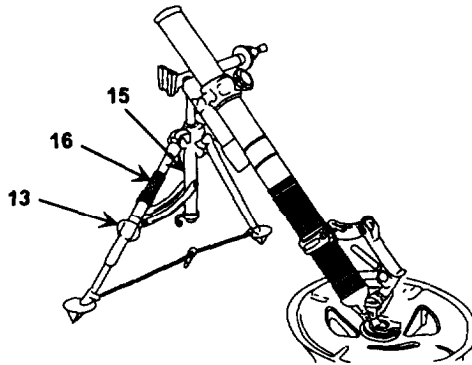

INSTALLATION OF M64/M64A1 SIGHT UNIT

CAUTION

When mortar is not in use, store sight unit carefully in its carrying case.

1. Remove M64/M64A1 sight unit (1) from sight unit case.
2. Press latching lever (2) while installing sight unit (1) into dovetail slot (3) on bipod.
3. Release latching lever (2) and check to ensure that sight unit (1) is firmly locked to bipod.

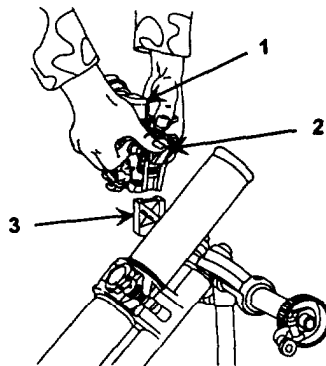

ASSEMBLY AND PREPARATION FOR FIRING - CONVENTIONAL MODE
- Continued

0005 00

INSTALLATION OF M64/M64A1 SIGHT UNIT - Continued

4. Ensure that mortar is set in upper saddle (4) (saddle closest to muzzle) (p 0005 00-2).
5. Ensure that elevating mechanism (5) and traversing mechanism (6) are approximately centered on bipod (7).
6. Remove gun muzzle cover (8) (item 5, Basic Issue Items, WP 0021 00) and clean muzzle surface with wiping rag (item 16, WP 0023 00).
7. Make sure mortar tube angle and propellant charge will fire no less than 300 meters during training firings.

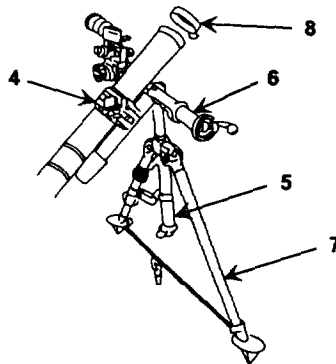

CAUTION

Do not use force on locking lever to lock.

8. Pull locking lever (9) up and rotate telescope (10) to vertical position, as shown.
 - a. M64 Only.
Align top index line (11) on loop clamp with line (12) on telescope (10). Push locking lever (9) down to lock.
 - b. M64A1 Only.
Push locking lever (9) down to lock. Loosen wing nut (13) and rotate telescope (10) to align top index line (11) on holder assembly with line (12) on telescope. Tighten wing nut.

ASSEMBLY AND PREPARATION FOR FIRING - CONVENTIONAL MODE
 - Continued

0005 00

INSTALLATION OF M64/M64A1 SIGHT UNIT - Continued

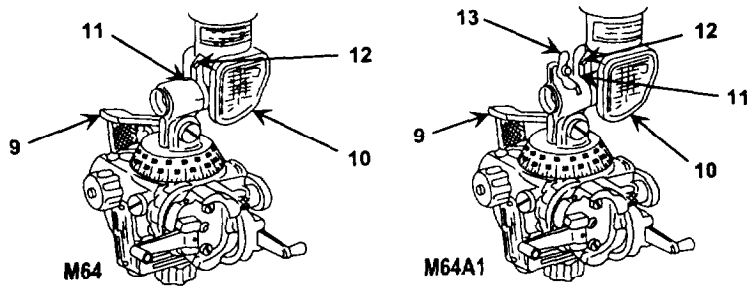

NOTE

Sight unit removed from bipod for clarity.

9. Loosen elevation locking knob (14). Rotate elevation knob (15) to align the 0800-mil graduation on coarse elevation scale (16) with coarse elevation index arrow (17).
10. Loosen deflection locking knob (18). Rotate deflection (azimuth) knob (19) to align red index line (20) with coarse azimuth index arrow (21).

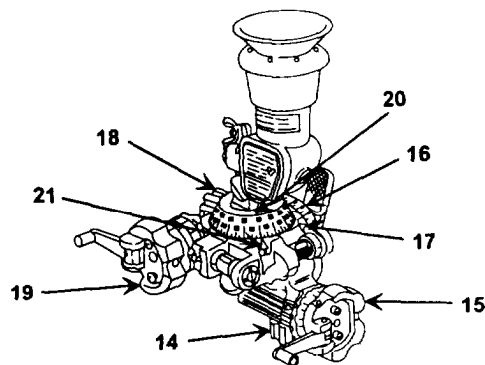

ASSEMBLY AND PREPARATION FOR FIRING - CONVENTIONAL MODE
- Continued

0005 00

INSTALLATION OF M64/M64A1 SIGHT UNIT - Continued

11. Remove cant, if present, by turning plain wing nut (22) and cross-leveling nut (23) on left leg of bipod until bubble of cross-level vial (24) on sight unit (1) is centered.

NOTE

Do not touch azimuth (deflection) knob on the M64/M64A1 sight unit.

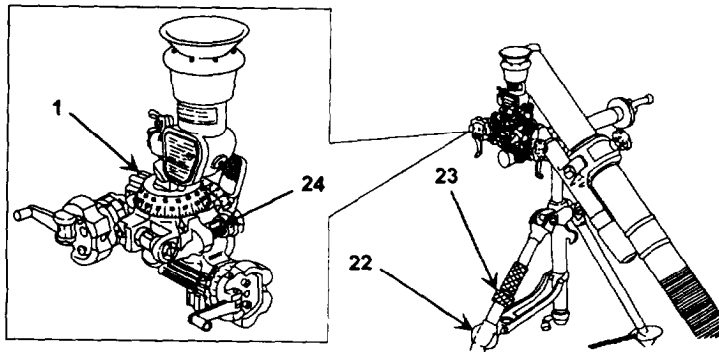

ASSEMBLY AND PREPARATION FOR FIRING - CONVENTIONAL MODE
- Continued

0005 00

BORESIGHTING

1. Check that elevation and traversing mechanisms are approximately centered.
2. Make a visual check that the elbow telescope is roughly parallel to the cannon.
3. If coarse azimuth (deflection) scale (1) is not set at 3200 mils, set it by pushing down around the circumference of the coarse azimuth (deflection) scale, turning it to 32, and releasing it.
4. Set fine azimuth (deflection) scale (2) to 0 mils.
5. Set coarse elevation scale (3) to 800 mils.

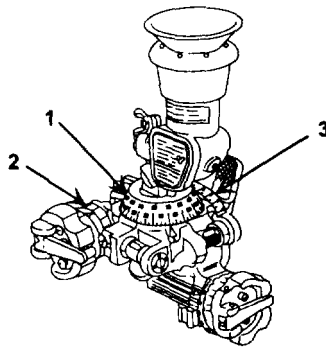

6. Select aiming point (4) that has clearly defined vertical line. The aiming point should be as far away as possible and not less than 200 meters. If distant aiming point is not available, use sight unit case (item 3, Basic Issue Items, WP 0021 00) (5) 10 meters away.

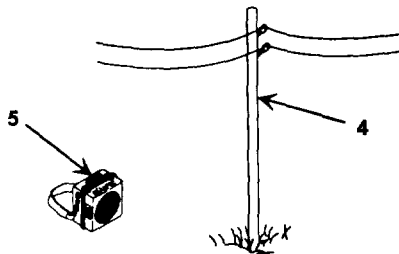

ASSEMBLY AND PREPARATION FOR FIRING - CONVENTIONAL MODE
- Continued

0005 00

BORESIGHTING - Continued

NOTE

Always sight along left edge of aiming point.

7. Look through elbow telescope (6) and pick out distant aiming point. Move mortar if necessary to place cross hairs on distant aiming point. Do not use traversing mechanism, but physically pick up mortar to align it on aiming point.
8. Check both level bubbles and adjust if necessary using mortar controls only. You are now ready to boresight.

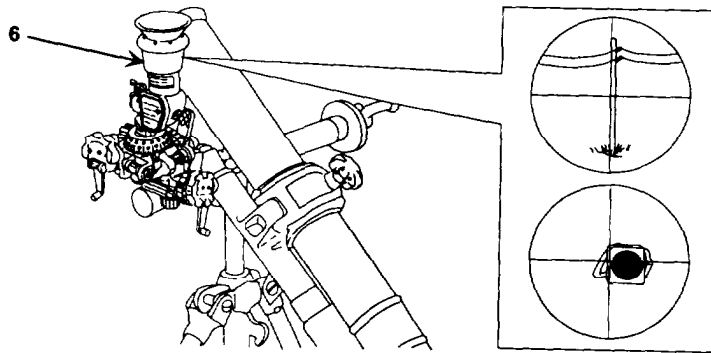

9. Remove M115 boresight (7) from sight unit case and place it on end of muzzle. Depress plungers of M115 boresight with flat-tip screwdriver (item 13, Basic Issue Items, WP 0021 00) and snap it in place against end of muzzle.

NOTE

The M45/M45A1 boresight is an acceptable replacement for the M115. Refer to FM 23-90.

10. Recheck azimuth (deflection) level vial in sight unit for centering of bubble. Adjust if necessary.

ASSEMBLY AND PREPARATION FOR FIRING - CONVENTIONAL MODE
 - Continued

0005 00

BORESIGHTING - Continued

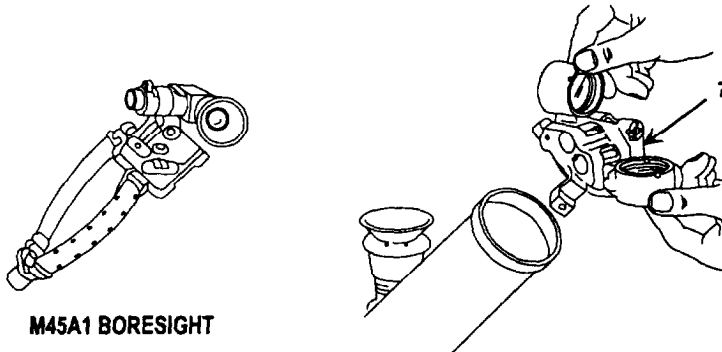

11. Rotate M115 boresight (7) to center bubble in boresight cross-level vial (8).
12. While viewing through boresight optic, turn traversing crank (9) to traverse the mortar until aligned with aiming point.

NOTE

The boresight line is a white line. View through center of the optic and up close; otherwise, boresight line will be fuzzy and distorted.

13. Recheck all other leveling vials on sight unit (10) and recenter bubbles if needed.

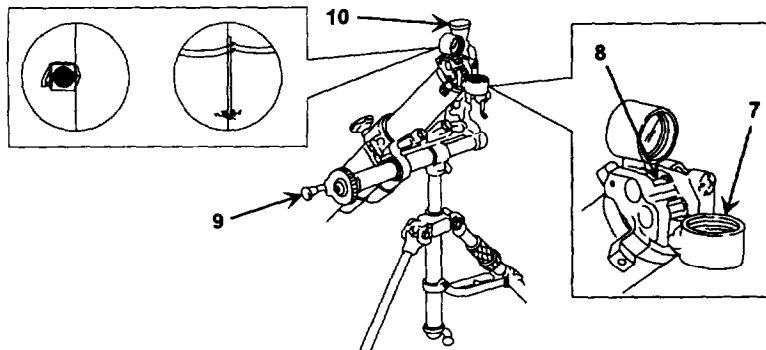

ASSEMBLY AND PREPARATION FOR FIRING - CONVENTIONAL MODE
- Continued

0005 00

BORESIGHTING - Continued

NOTE

Azimuth and elevation locking knobs must be unlocked prior to adjustments.

14. Center bubble in elevation vial (11) on sight unit (10), wing elevation knob (12).
15. Check all other leveling vials for centered bubbles.
16. Sight through boresight (7) to check that boresight line is on right side of 10 meter target. If not, align target using traversing crank (9).
17. Recheck centering of all bubbles and adjust as necessary.

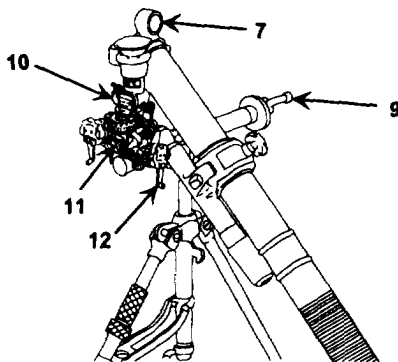

ASSEMBLY AND PREPARATION FOR FIRING - CONVENTIONAL MODE
- Continued

0005 00

BORESIGHTING - Continued

18. Sight through elbow telescope (6) to check that vertical cross hair is on left side of 10 meter or distant target. If not, use fine azimuth (deflection) knob (13) to align cross hair of sight unit on target as shown.
19. Recheck centering of all bubbles and adjust as necessary.

CAUTION

Tampering with the coarse elevation scale could cause damage to the scale or sight unit.

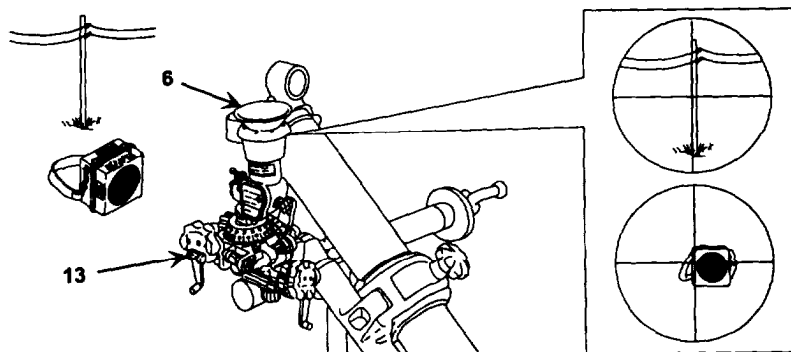

ASSEMBLY AND PREPARATION FOR FIRING - CONVENTIONAL MODE

- Continued

0005 00

BORESIGHTING - Continued

20. Cannon tube (14) is now at 800 mils. Coarse elevation index arrow (15) should point to 8 (800 mils) on coarse elevation scale (3). If a mismatch exceeds 1/4 graduation (approximately plus or minus 20 mils), remove and replace sight unit (10).
21. Recheck centering of all bubbles and adjust as necessary.

CAUTION

Do not over-tighten screws.

22. Fine elevation scale (16) should be on 0. If not, lock elevation knob (12) with locking knob (17). Loosen two screws (18) and slip fine elevation scale until 0 aligns with red index arrow (19) on the housing. Tighten two screws. Loosen locking knob.
23. Recheck centering of all bubbles and adjust as necessary.

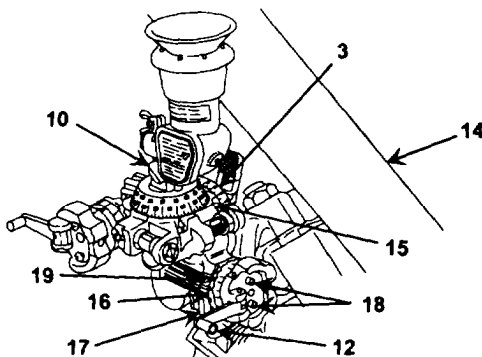

ASSEMBLY AND PREPARATION FOR FIRING - CONVENTIONAL MODE
- Continued

0005 00

BORESIGHTING - Continued

24. Check to see if coarse azimuth (deflection) scale (1) is set at 3200 mils.

NOTE

Deflection of 3200 mils means 32 on coarse azimuth (deflection) scale and 0 on fine azimuth (deflection) scale.

25. If not, set at 3200 mils by pushing down on the complete circumference of coarse azimuth (deflection) scale (1), turning it to 32, and releasing it.
26. Set fine azimuth (deflection) scale (2) to zero by turning fine azimuth (deflection) knob (13).

CAUTION

Do not over-tighten screws.

27. The red index line (20) on inner coarse azimuth (deflection) scale (21) should also align with 32 on coarse azimuth (deflection) scale (1). If it does not, lift up on locking lever (22), pivot elbow telescope (6) out of the way, and loosen two screws (23). Turn inner coarse azimuth (deflection) scale until red line is at 32. Tighten two screws. Reposition elbow telescope and secure by pushing down on locking lever.

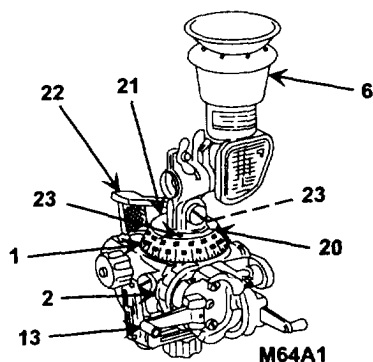

ASSEMBLY AND PREPARATION FOR FIRING - CONVENTIONAL MODE**- Continued****0005 00**

BORESIGHTING - Continued

28. Fine azimuth (deflection) red index arrow (24) should align with red index line (25) on outer fine azimuth (deflection) scale (26). Fine azimuth (deflection) black arrow (27) should align with 0 on fine azimuth (deflection) scale (2). If it does not, tighten azimuth locking knob (28) and loosen two screws (29).
29. Rotate outer fine azimuth (deflection) scale (26) and set red index line (25) to red index arrow (24).
30. Depress fine azimuth (deflection) scale (2) and turn to align 0 with fine azimuth (deflection) black arrow (27). Tighten two screws (29) and loosen azimuth locking knob (28).

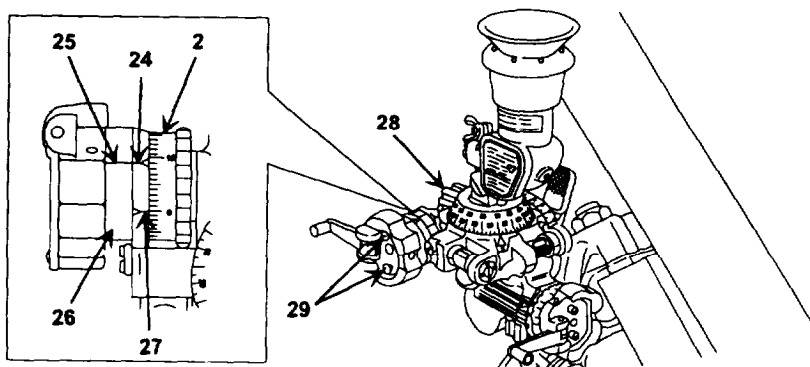

31. Recheck sight unit as follows:
 - a. Sight unit crosshair lined up on target.
 - b. Bubble in cross-level vial (30) is centered.
 - c. Bubble in elevation vial (11) is centered.
 - d. Red index line (20) is on 32.
 - e. Coarse azimuth (deflection) scale (1) is on 32.
 - f. Fine azimuth (deflection) scale (2) is on 0.
 - g. Coarse elevation scale (3) is on 8.
 - h. Fine elevation scale (16) is on 0.

BORESIGHTING - Continued

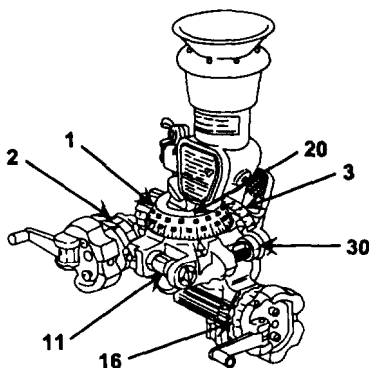

32. View through boresight (7) to make sure it lines up on aiming point target.
33. Check for reticle accuracy as follows:
 - a. Rotate boresight 180 degrees so bottom lens is now on top and bubble in other cross-level vial (8) is recentered.
 - b. Sight through boresight again; the sight picture should be the same as shown on p 0005 00-11.
 - c. If the sight picture is not the same, check sight unit vials to make sure mortar did not move.
 - d. If bubbles in sight unit level vials are still centered, the boresight is defective. Replace boresight and turn in defective boresight for maintenance.

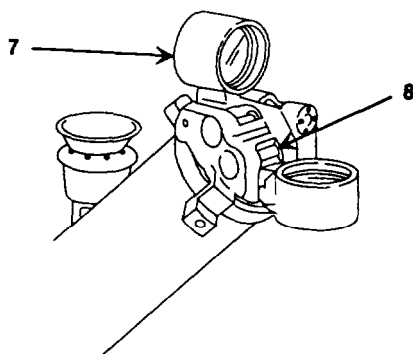

ASSEMBLY AND PREPARATION FOR FIRING - CONVENTIONAL MODE
- Continued

0005 00

BORESIGHTING - Continued

NOTE

If no more adjustments are required, boresighting is complete.

34. Remove boresight (7) from muzzle and stow it in sight unit case (item 3, Basic Issue Items, WP 0021 00). Install gun muzzle cover (item 5, Basic Issue Items, WP 0021 00) on mortar until ready to fire.

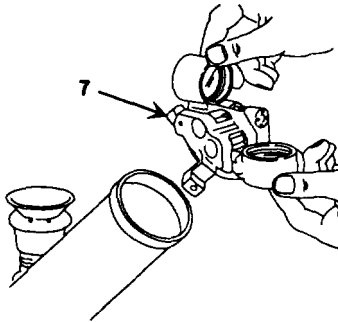

END OF TASK

THIS WORK PACKAGE COVERS:

Assembly of Mortar

INITIAL SETUP:

Maintenance Level

Operator

References

AR 385-63

ASSEMBLY OF MORTAR

WARNING

Firing site must have mask clearance and no overhead obstructions.

Firing over the heads of unprotected troops is prohibited per AR 385-63.

When firing during training, the minimum horizontal range is 300 meters.

1. Place lower slope of M8 baseplate (1) in direction of fire.

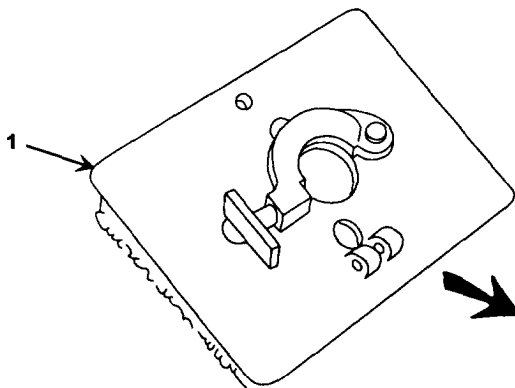

ASSEMBLY AND PREPARATION FOR FIRING - HAND-HELD MODE - Continued 0006 00

ASSEMBLY OF MORTAR - Continued

2. Pull latch knob (2) and rotate latch (3) open.

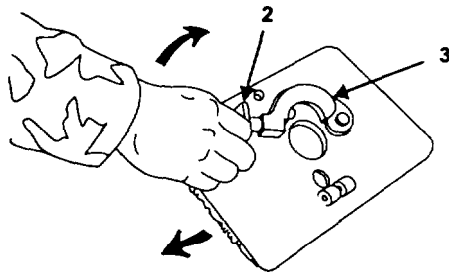

3. Insert basecap (4) of cannon into socket of baseplate. Close latch (3). Make sure latch pin seats.

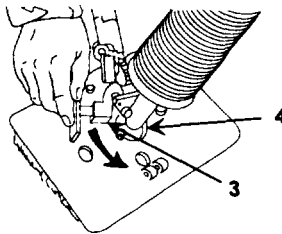

END OF TASK

EMPLACING AIMING POSTS FOR INDIRECT FIRE

0007 00

THIS WORK PACKAGE COVERS:

Emplacement of Aiming Posts

INITIAL SETUP:

Maintenance Level

Operator

Materials/Parts

M14 aiming post (item 11, Basic Issue Items, WP 0021 00)

M58 aiming post light (item 8, Basic Issue Items, WP 0021 00)

M59 aiming post light (item 9, Basic Issue Items, WP 0021 00)

EMPLACEMENT OF AIMING POSTS

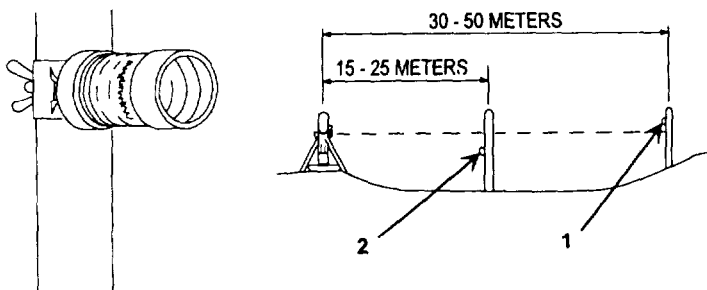

1. Place two sets of assembled aiming posts (item 11, Basic Issue Items, WP 0021 00) in ground in a line 2800 mils deflection from direction of fire. The far post should be emplaced first 30 to 50 meters from weapon where possible. Emplace near post halfway between far post and weapon.

EMPLACEMENT OF AIMING POSTS - Continued**WARNING**

Take care in handling mortar components which contain radioactive tritium H_3 . These components are the range indicator assembly, the sight units M64/M64A1, and the aiming post lights M58/M59. If damage occurs, refer to WARNING information in the front of this manual for special handling instructions.

2. Attach aiming post lights (items 8 and 9, Basic Issue Items, WP 0021 00) to aiming posts by tightening wing nut on light clamp. Position so lights can be seen at night through the sight. Far post light (1) should be visible above near light (2). Aiming post lights should be different colors.

END OF TASK

THIS WORK PACKAGE COVERS:

Loading and Firing

INITIAL SETUP:

Maintenance Level

Operator

Materials/Parts

Artillery cleaning hook (item 7, Basic Issue Items, WP 0021 00)

Wiping rag (item 16, WP 0023 00)

References

WP 0024 00

FT 60-P-1

Equipment Conditions

Mortar has been boresighted (WP 0005 00)

LOADING AND FIRING

WARNING

Loading a mortar weapon with two men (alternately) can be very dangerous and could prove fatal. Even with one-man loading, double loading can occur. This is especially true in rapid fire exercises. For this reason, it is imperative that there is absolute certainty that the previous round has left the mortar tube before a new round is dropped in.

1. Select firing tables FT 60-P-1 for ammunition to be fired.

WARNING

Short rounds may occur if an excessive amount of oil or water is in barrel during firing.

CAUTION

Do not wet swab the cannon bore during firing.

2. Dry swab cannon bore using artillery cleaning hook (item 7, Basic Issue Items, WP 0021 00) and wiping rag (item 16, WP 0023 00) before firing, after every ten rounds fired (approximately), and at the end of each fire mission.

LOADING AND FIRING - Continued

WARNING

Selector should be at S (safe) except when firing.

Misalignment of safe detent position on firing selector will cause a malfunction which may accidentally arm the mortar and can result in unintentional discharge of round. Injury or death may occur.

CAUTION

Trigger firing without a round in the barrel will cause rapid failure of the sear. Trigger firing without a round should be limited to inspection for operation only.

3. Set firing selector (1):
For drop fires, set firing selector (1) to D. Round fires when dropped. With firing selector at T, trigger (2) is away from handle. Round fires when trigger is squeezed toward handle. Release trigger after each firing.

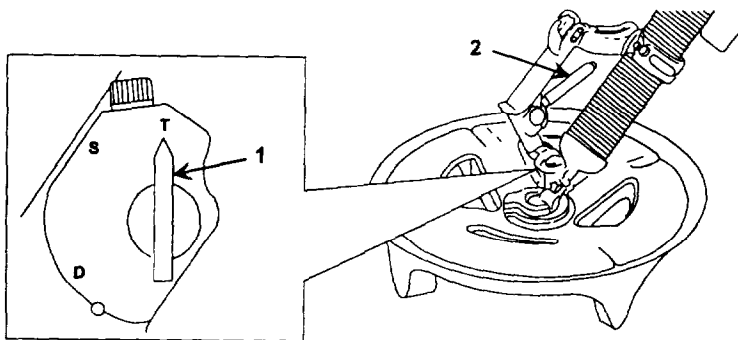

LOADING AND FIRING - Continued

4. Gunner kneels on left side of cannon and looks into sight unit. Assistant gunner kneels on right side in front of traversing mechanism facing gunner. The ammunition handler kneels beside the assistant gunner and slightly to the rear.

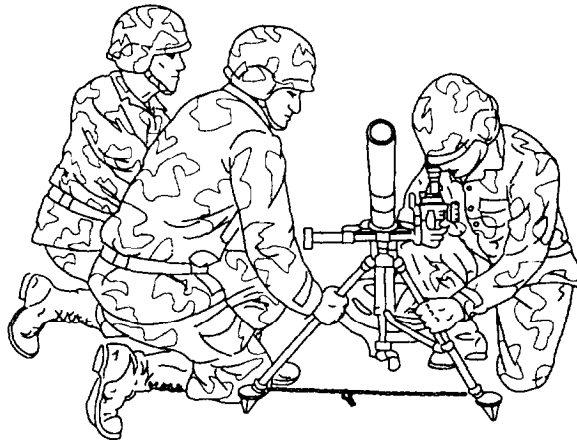

WARNING

If using M525 or M527 PD fuzes, see inspections and warnings on pages 0024 00-7 and 0024 00-8.

Do not fire unpacked ammunition which has been dropped, or packaged ammunition which has been dropped from a height greater than one meter. These cartridges will be returned to Ammunition Supply Point (ASP) as unserviceable.

5. Ammunition handler adjusts propellant charge for desired range, sets fuze for burst desired, and removes safety wire/pin (see p 0024 00-12 through 0024 00-18).

LOADING AND FIRING - Continued

WARNING

Do not look into cannon or try to force a cartridge down the bore.

6. Assistant gunner grasps the body of the round with both hands near the center and inserts round, fuze end up, beyond narrow part of body.

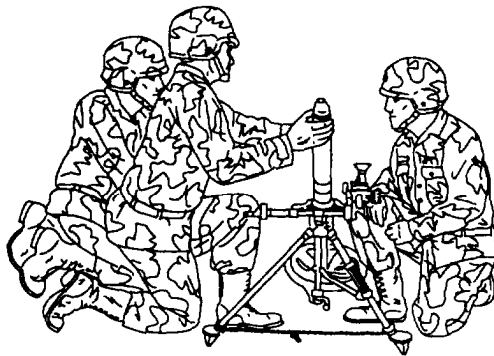

WARNING

All personnel within 50 meters of the firing position must wear single hearing protection during all firings.

The gunner and assistant gunner will use single hearing protection while maintaining a head position at least one meter to the side and one meter or more to the rear of the muzzle. Head positions should be below the muzzle when a round is fired. Under these conditions, no more than 100 rounds per day may be fired by the crew.

7. At command to fire, assistant gunner releases round and passes hands partly down outside surface of barrel while pivoting to his left, and bending toward ammunition handler for next round.

LOADING AND FIRING - Continued

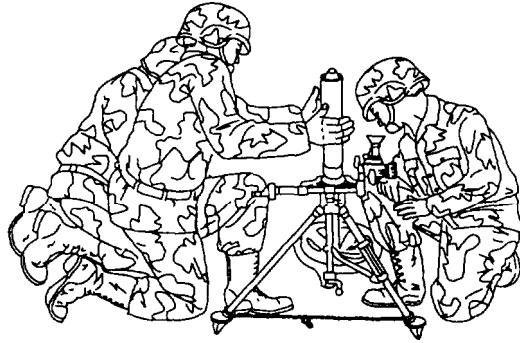

8. Gun will fire in accordance with selection.

END OF TASK

LOADING AND FIRING - HAND-HELD MODE

0009 00

THIS WORK PACKAGE COVERS:

Loading and Firing

INITIAL SETUP:

Maintenance Level

Operator

Materials/Parts

Artillery cleaning hook (item 7, Basic Issue Items, WP 0021 00)

Heat protective mitten (item 10, Basic Issue items, WP 0021 00)

Wiping rag (item 16, WP 0023 00)

References

WP 0024 00

Equipment Conditions

Cannon tube installed in M8 baseplate (WP 0006 00)

LOADING AND FIRING

WARNING

Loading a mortar weapon with two men (alternately) can be very dangerous and could prove fatal. Even with one-man loading, double loading can occur. This is especially true in rapid fire exercises. For this reason, it is imperative that there is absolute certainty that the previous round has left the mortar tube before a new round is dropped in.

LOADING AND FIRING - Continued

WARNING

In hand-held mode, place baseplate against a solid object when:

Firing at ranges more than 300 meters for charge zero.

Firing at ranges of more than 900 meters for charge one.

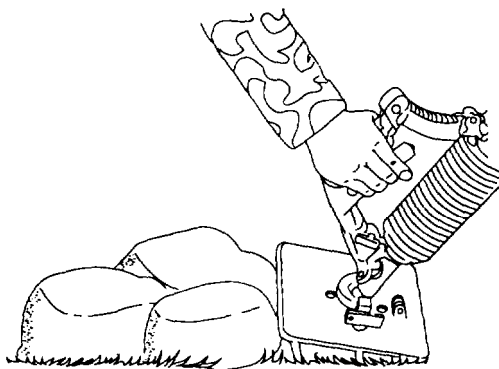

In hand-held mode, do not fire with any charge greater than the following:

M720/M888 cartridge:	Charge one
M49A4 cartridge:	Charge three
M83 series cartridge:	Charge two
M302A1 cartridge:	Charge two

LOADING AND FIRING - Continued

WARNING

Take care in handling mortar components which contain radioactive tritium H_3 . These components are the range indicator assembly, the sight units M64/M64A1, and the aiming post lights M58/M59. If damage occurs, refer to WARNING information in the front of this manual for special handling instructions.

NOTE

Range indicator assembly (M720/M888 cartridges only): A vial containing a ball (1) that moves when cannon is elevated or depressed and indicates the firing range.

The black scale (2) is for charge one. The red scale (3) is for charge zero.

The yellow index (range 3 on red scale and range 10 on black scale) is a warning reminder to brace the baseplate. (See warning on page 0009 00-2).

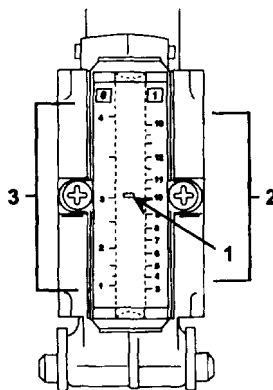

LOADING AND FIRING - Continued

WARNING

All personnel within 50 meters of the firing position must wear single hearing protection during all firings.

The gunner and assistant gunner will use single hearing protection while maintaining a head position at least one meter to the side and one meter or more to the rear of the muzzle. Head positions should be below the muzzle when a round is fired. Under these conditions, no more than 100 rounds per day may be fired by the crew.

Short rounds may occur if an excessive amount of oil or water is in barrel during firing.

CAUTION

Do not wet swab the cannon bore during firing.

1. Dry swab cannon bore with artillery cleaning hook (item 7, Basic Issue Items, WP 0021 00) and wiping rag (item 16, WP 0023 00), before firing and after every ten rounds fired.
2. Gunner kneels directly behind barrel with heat protective mitten (item 10, Basic Issue Items, WP 0021 00) on left hand and his right hand around the trigger and handle.

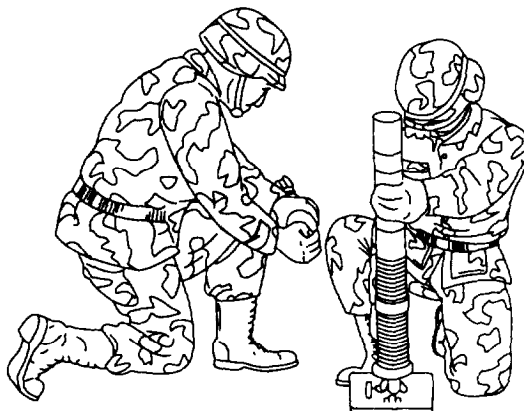

LOADING AND FIRING - Continued

WARNING

If using M525 or M527 PD fuzes, see inspections and warnings on pages 0024 00-7 and 0024 00-8.

3. Ammunition handler prepares propellant charge for desired range, sets fuze for burst desired, and removes safety wire/pin (see p 0024 00-12 through 0024 00-18).
4. Gunner sets firing selector at T.
5. Assistant gunner grasps round near center, inserts round (fuze end up) in muzzle, releases round, and assumes safe firing position.

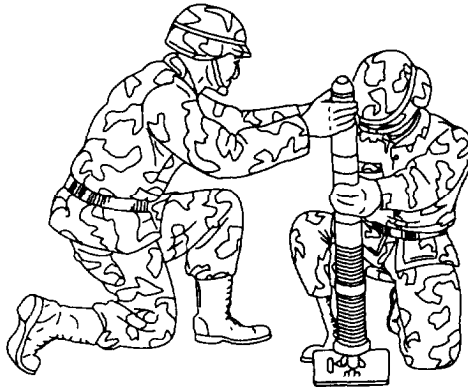

6. Gunner lays weapon using range indicator assembly and sight over or on side of muzzle for azimuth. Holding mortar steady, gunner assumes safe firing position.
7. When weapon is on target, gunner squeezes trigger to fire and then releases trigger after firing.

END OF TASK

MISFIRE PROCEDURE - CONVENTIONAL MODE

0010 00

THIS WORK PACKAGE COVERS:

Removal of Round

INITIAL SETUP:

Maintenance Level

Operator

Personnel Required

Two

REMOVAL OF ROUND

WARNING

Never stand or kneel behind or in front of the cannon tube. Stand or kneel on either side.

Never attempt to remove a misfired round from a hot cannon.

Do not look into cannon or try to force a cartridge down the bore.

If misfire occurs with an unseated baseplate in the conventional mode, do not attempt to trigger fire the mortar. (Skip steps 2 through 8.) Place selector lever on S and proceed with the remainder of the misfire procedure in this manual.

Two people are required to remove a misfire. Evacuate all others at least 50 meters to the right or left rear of the weapon.

NOTE

A MISFIRE is the failure of a cartridge to fire when round is dropped with selector lever set on D or when trigger is squeezed with selector lever on T.

A HANGFIRE is delay in the functioning of a propelling charge explosive train at the time of firing.

A COOKOFF is the firing of the cartridge due to a round chambered in a hot weapon.

REMOVAL OF ROUND - Continued

1. Any crew member shouts MISFIRE.
2. Assistant gunner will brace the bipod.
3. The gunner kicks the barrel twice; round should fire.

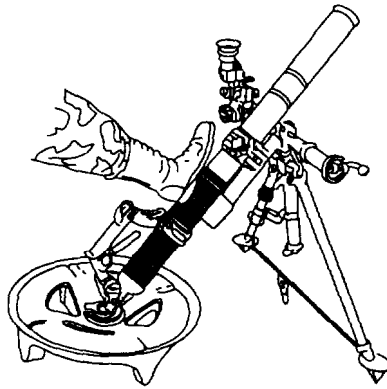

4. If round fires, the mortar is relaid and firing is continued.
5. If time permits, swab the bore before firing is continued to remove any debris that may have caused the misfire.
6. If round does not fire, perform steps 7 through 22.

REMOVAL OF ROUND - Continued

WARNING

Trigger firing with an unseated baseplate is prohibited in the conventional mode.

NOTE

If baseplate is not well seated, omit steps 7 and 8 and go to step 9.

7. If round does not fire and baseplate is well seated, place firing selector on T.
8. Squeeze trigger twice; round should fire.

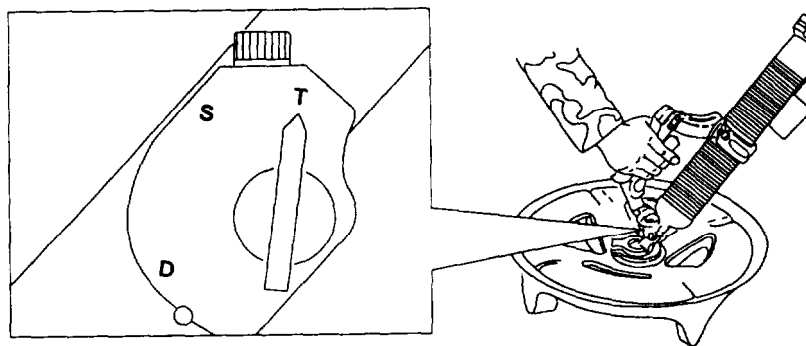

REMOVAL OF ROUND - Continued

9. If round still does not fire, place firing selector on S.

WARNING

Never attempt to remove a misfired round from a hot cannon.

10. Allow cannon tube to cool until it can be held with bare hands. Cooling with water is allowable.

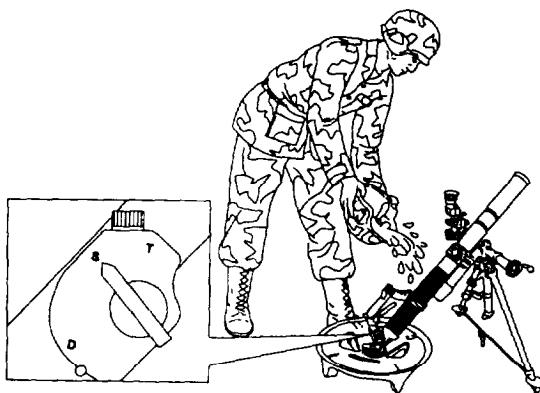
**CAUTION**

M64/M64A1 sight unit must be removed before continuing.

11. Lower cannon (1) to lowest elevation and remove sight unit (2) by pressing on latch (3) and sliding the sight unit out of the dovetail slot (4) on the bipod.
12. Rotate elbow telescope (5) to horizontal position. Lock knobs on sight unit (2) on last deflection and place in sight unit case (6).

NOTE

Do not unlock collar knob.

13. Loosen collar knob (7) only enough to allow cannon (1) to rotate.

REMOVAL OF ROUND - Continued

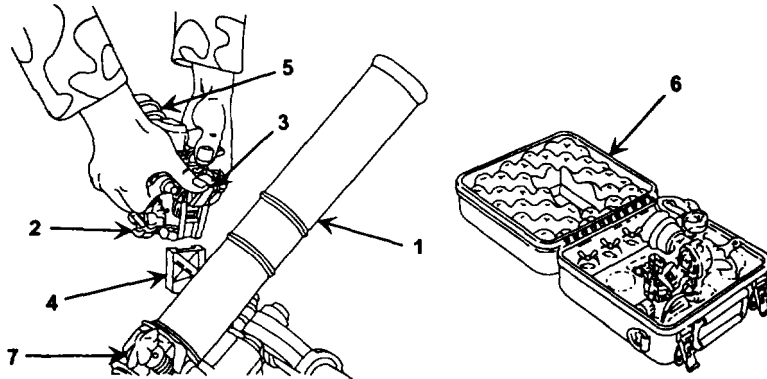

14. Rotate cannon (1) 90 degrees at handle toward gunner, and lift basecap out of baseplate.

WARNING

Do not put hands on basecap when lifting and holding breech end of cannon tube.

After lifting mortar out of baseplate, never allow breech cap end to go below horizontal position until the round is removed.

Never put your hands behind or in front of the muzzle.

15. Gunner at handle lifts breech end (8) of cannon (1) and assistant gunner places hands around muzzle.

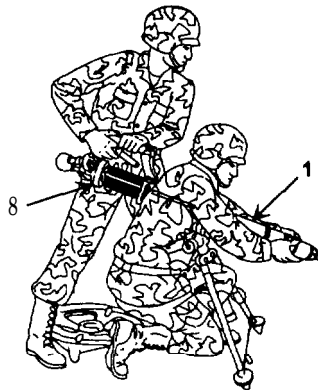

REMOVAL OF ROUND - Continued

16. As breech end is lifted, round should slide out. Assistant gunner stops it with his thumbs, removes it from bore, and passes it to the ammunition handler.

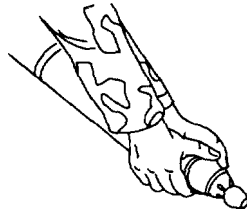

17. If safety wire can be replaced, replace it and place suspect round in misfire pit. Notify Explosive Ordnance Disposal (EOD).
18. If safety wire can't be replaced, fuze may be armed. Lay suspect round flat on ground, evacuate area, and notify EOD.
19. If round won't slide out of cannon, remove cannon from bipod and lay it flat on ground in direction of fire. Notify EOD.
20. When round is removed, lift base as high as possible and shake cannon to dislodge any debris.
21. Reassemble and r-e-lay mortar.
22. Swab cannon tube.

WARNING

If you get two misfires in a row, stop firing and notify unit maintenance.

END OF TASK

MISFIRE PROCEDURE - HAND-HELD MODE

0011 00

THIS WORK PACKAGE COVERS:

Removal of Round

INITIAL SETUP:

Maintenance Level

Operator

References

WP 0010 00

Personnel Required

Two

REMOVAL OF ROUND

WARNING

Never stand or kneel behind or in front of the cannon tube. Stand or kneel on either side.

Do not look into cannon or try to force a cartridge down the bore.

Never attempt to remove a misfired round from a hot cannon.

NOTE

Firing malfunction definitions are in WP 0010 00.

1. If round doesn't fire, squeeze trigger a second time to confirm malfunction.
2. If round doesn't fire after second trigger squeeze, any crew member shouts MISFIRE.

REMOVAL OF ROUND - Continued

WARNING

Do not bounce weapon more than 6 inches from the ground.

3. Place firing selector on S and bounce weapon on ground, or support weapon with a stick, sandbag, or empty ammunition box and kick cannon, to dislodge round.
4. Place firing selector on T. Clear target area and re-aim.
5. Squeeze trigger twice; round should fire.
6. If round doesn't fire, place firing selector on S. Support cannon (with a stick, sandbags, empty ammunition boxes, etc.). Cool outer surface with water or allow to air cool until cannon tube can be held with bare hands.



REMOVAL OF ROUND - Continued

WARNING

After lifting basecap end of mortar, never allow basecap end to go below horizontal position until round is removed.

Never put your hands behind or in front of the muzzle.

7. Gunner lifts basecap end (1) of cannon and assistant gunner places hands around muzzle.
8. As basecap end (1) is lifted, round (2) should slide out. Assistant gunner stops it with his thumbs and removes it from bore.
9. If safety wire can be replaced, replace it and place suspect round in misfire pit. Notify Explosive Ordnance Disposal (EOD).

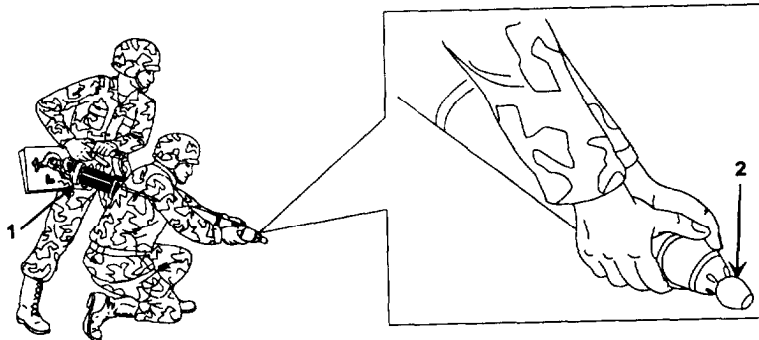

10. If safety wire can't be replaced, fuze may be armed. Lay suspect round flat on ground, evacuate area, and notify EOD.

MISFIRE PROCEDURE - HAND-HELD MODE - Continued

0011 00

REMOVAL OF ROUND - Continued

11. If a round won't slide out of cannon, lay cannon flat on ground in direction of fire. Notify EOD.
12. When round is removed, lift base as high as possible and shake cannon to dislodge any debris.
13. Reassemble and re-lay mortar.
14. Swab cannon tube if time permits.

WARNING

If you get two misfires in a row, stop firing and notify unit maintenance.

END OF TASK

PREPARATION FOR MOVEMENT - CONVENTIONAL MODE

0012 00

THIS WORK PACKAGE COVERS:

One Man Carry, Two Man Carry, Three Man Carry

INITIAL SETUP:

Maintenance Level

Operator

Materials/Parts

Aiming post case (item 2, Basic Issue Items, WP 0021 00)

Sight unit case (item 3, Basic Issue Items, WP 0021 00)

Small arms sling (item 14, Basic Issue Items, WP 0021 00)

ONE MAN CARRY

WARNING



Take care in handling mortar components which contain radioactive tritium H_3 . These components are range indicator assembly, sight units M64/M64A1, and aiming post lights M58/M59. If damage occurs, refer to WARNING information in the front of manual for special handling instructions.

ONE MAN CARRY - Continued

NOTE

Mortar balances better with bipod attached to upper saddle, especially if you do not have a small arms sling.

1. Lower cannon to lowest elevation and remove sight unit (1) by pressing on latch (2) and sliding the sight unit out of the dovetail slot (3) on the bipod.
2. Stow sight unit (1) per instructions provided in sight unit case.

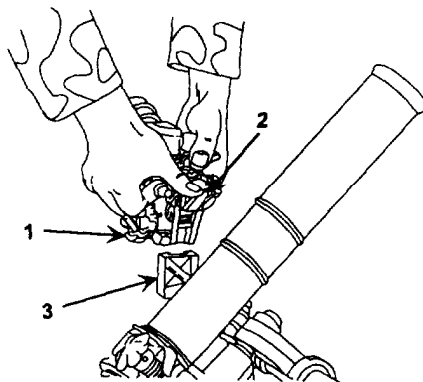

3. Remove lights from aiming posts and stow lights in sight unit case (4) (item 3, Basic Issue Items, WP 0021 00).

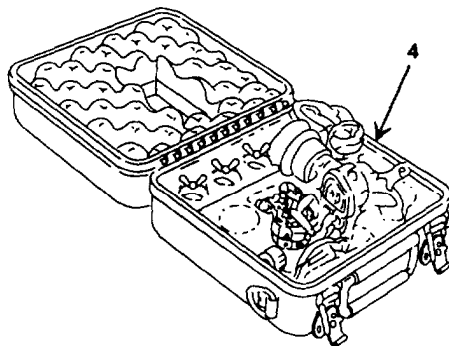

ONE MAN CARRY - Continued

4. Retrieve aiming posts and place in aiming post case (5) (item 2, Basic Issue Items, WP 0021 00).

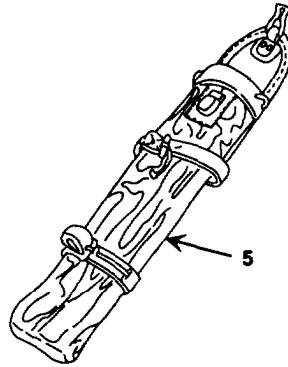

5. Center traversing mechanism (6) and fully depress elevating mechanism (7).
6. Swing mortar mount legs (8) together and lock plain wing nut (9).
7. Fold bipod underneath cannon (10) and latch elevating mechanism (7) to bipod yoke (11).
8. Pass one end of wire rope assembly (12) through opening in baseplate (13) and fasten snap hook to wire rope assembly.

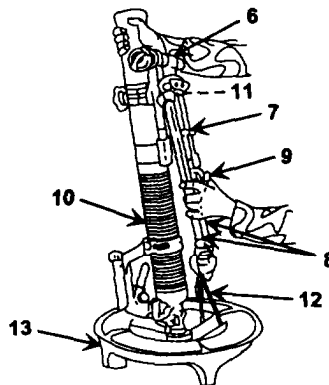

ONE MAN CARRY - Continued

9. Attach small arms sling (14) (item 14, Basic Issue Items, WP 0021 00), with one end slid over muzzle, through aiming post case carrying strap and with the other end fastened around basecap. Attach muzzle cover (15).
10. Swing carrying handle (16) to carrying position.
11. Place small arms sling (14) over one shoulder, steady mortar with the carrying handle (16), and carry the sight unit case (4) with the other hand.

NOTE

Depending on conditions, the crewman may be carrying more equipment than shown in illustration.

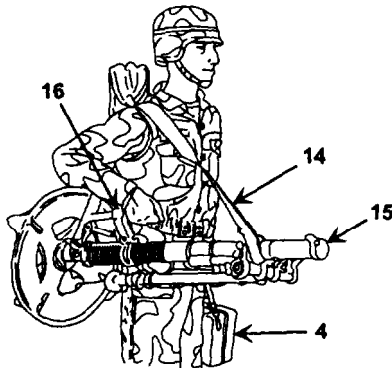

TWO MAN CARRY

WARNING

Take care in handling mortar components which contain radioactive tritium H_3 . These components are range indicator assembly, sight units M64/M64A1, and aiming post lights M58/M59. If damage occurs, refer to WARNING information in the front of manual for special handling instructions.

1. Remove sight unit from bipod (p 0012 00-2). Remove lights from aiming posts and stow lights in sight unit case (item 3, Basic Issue Items, WP 0021 00). Attach bipod (1) to lower saddle of cannon (2).

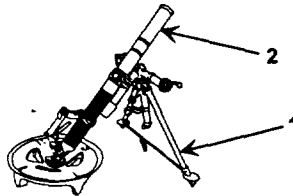

2. Retrieve aiming posts and place in aiming post case (3) (item 2, Basic Issue Items, WP 0021 00).

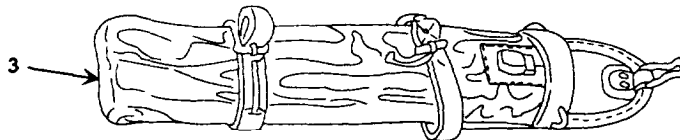

PREPARATION FOR MOVEMENT - CONVENTIONAL MODE - Continued

0012 00

TWO MAN CARRY - Continued

3. Detach baseplate (4) and wrap wire rope assembly (5) around basecap (6). Use snap hook to secure wire rope assembly. Attach muzzle cover (7).

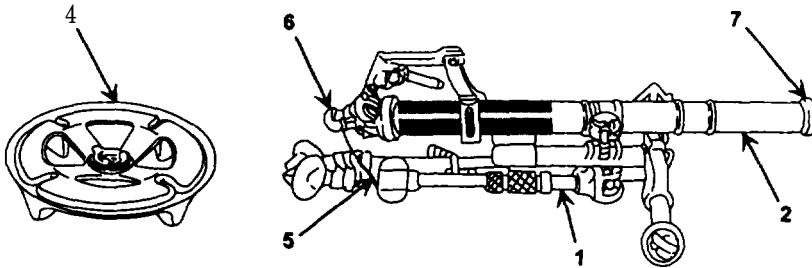

4. Gunner will carry cannon (2) and bipod (1) combination- assistant gunner carries baseplate (4), sight unit case (8), and aiming post case (3).

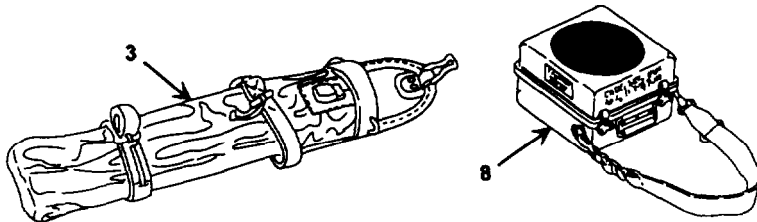

THREE MAN CARRY

WARNING

Take care in handling mortar components which contain radioactive tritium H_3 . These components include the range indicator assembly, sight units M64/M64A1, and the aiming post lights M58/M59. If damage occurs, refer to WARNING information in the front of this manual for special handling instructions.

1. Remove sight unit from bipod (p 0012 00-2). Remove lights from aiming posts and stow lights in sight unit case (1) (item 3, Basic Issue Items, WP 0021 00).
2. Retrieve aiming posts and place in aiming post case (2) (item 2, Basic Issue Items, WP 0021 00).

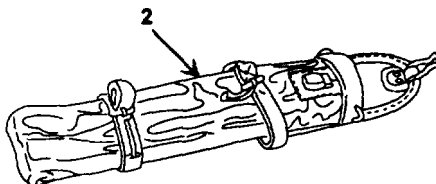
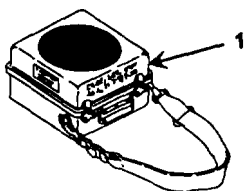

THREE MAN CARRY - Continued

3. Loosen knob on shock absorber assembly (3) and open collar. Remove cannon (4) from bipod (5) and close collar. Detach baseplate (6). Close bipod and wrap wire rope assembly (7) around bipod legs. Use snap hook to secure wire rope assembly. Attach muzzle cover (8).
4. The gunner carries cannon (4); assistant gunner carries bipod (5) and sight unit case (1); ammunition handler carries baseplate (6) and aiming post case (2).

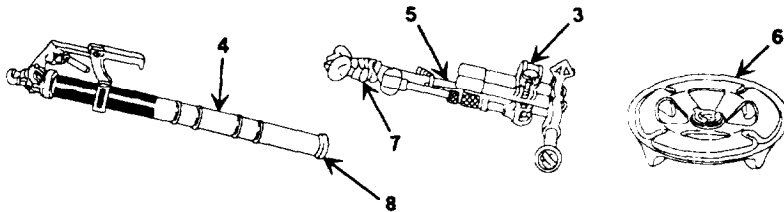

END OF TASK

THIS WORK PACKAGE COVERS:

Carrying Mortar

INITIAL SETUP:

Maintenance Level

Operator

Materials/Parts

Small arms sling (item 14, Basic Issue Items, WP 0021 00)

CARRYING MORTAR

WARNING

Ensure that cannon is empty and firing selector is on S (safe) before carrying mortar.

1. Lift cannon (1) and baseplate (2).
2. Rotate baseplate (2) 1/4 turn.
3. Align baseplate quick release plungers (3) to mate with cannon catch (4).
4. Swing baseplate (2) against right side of cannon (1) and press baseplate until it latches.

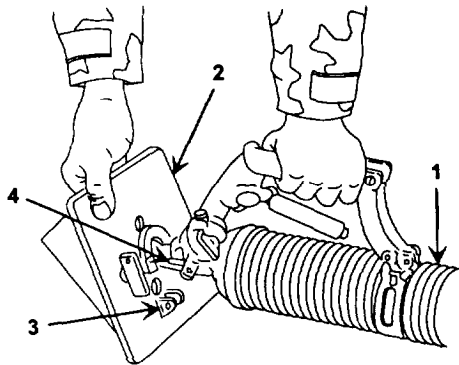

CARRYING MORTAR - Continued

5. Depress detent plunger (5) and swing carrying handle (6) forward.
6. Attach small arms sling (item 14, Basic Issue Items, WP 0021 00), if desired.

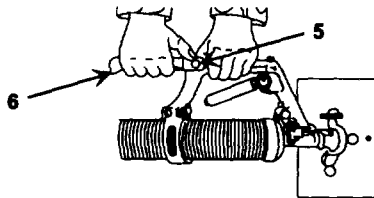

END OF TASK

OPERATION UNDER UNUSUAL CONDITIONS

0014 00

COLD

Keep ammunition and fire control instruments covered. Do not move fire control instruments from cold to warm areas. Use LAW (item 13, WP 0023 00). Refer to FM 9-207, FM 31-70 and FM 31-71 for operation in cold climate.

HOT AND DRY

Clean equipment and wipe dry. Lubricate parts very lightly or operate dry. Keep equipment covered.

DAMP AND SALTY

Clean and lubricate more frequently. Keep equipment covered. Check optical instruments for fungus growth and condensation.

FORDING

Disassemble and cover weapon. Watch for seepage which could contaminate lubricant. If immersed, disassemble and perform scheduled lubrication.

FROZENGROUND

Loosen ground to seat baseplate spades and bipod feet or use tree bough or sand bags to emplace mortar.

SOFT MUD

Use any available material to keep baseplate from sinking.

SAND

Clean and lubricate more frequently. Remove lubricant from exposed parts before beginning an action. Clean and lubricate when action is over.

CHAPTER 3

TROUBLESHOOTING PROCEDURES FOR THE M224 60-MM MORTAR

INTRODUCTION

0015 00

GENERAL

This table lists the common malfunctions which you may find during the operation or maintenance of the 60mm mortar or its components. Perform the tests/inspections and corrective actions in the order listed.

This table cannot list all the malfunctions that may occur, all the tests and inspections needed to find the fault, or all the corrective actions needed to correct the fault. If the equipment malfunction is not listed or actions listed do not correct the fault, notify your supervisor.

TROUBLESHOOTING PROCEDURES

0016 00

THIS WORK PACKAGE COVERS:

60mm Mortar, M224

INITIAL SETUP:

Maintenance Level

Operator

Materials/Parts

General purpose lubricating oil (GPL) (item 12, WP 0023 00)

Rifle bore cleaning compound (RBC) (item 7, WP 0023 00)

Weapon lubricating oil (LAW) (item 13, WP 0023 00)

60MM MORTAR, M224

Table 1. Troubleshooting Procedures.

MALFUNCTION	TEST OR INSPECTION	CORRECTIVE ACTION
<p>1. ROUND FAILS TO FIRE.</p> <p style="text-align: center;">WARNING</p> <p>Follow misfire procedures in chapter 2 to remove round before doing troubleshooting.</p>	<ol style="list-style-type: none"> 1. Check selector position. 2. Check primer for dent from firing pin. 3. Check for dirty bore. 	<ol style="list-style-type: none"> 1. Set selector at D if firing by drop method. 2. Set selector at T if firing by trigger fire method. <p>If no dent present, notify unit maintenance.</p> <p>Clean tube thoroughly with RBC (item 7, WP 0023 00).</p>

Table 1. Troubleshooting Procedures - Continued.

MALFUNCTION	TEST OR INSPECTION	CORRECTIVE ACTION
2. SELECTOR WONT TURN.	Check for dirt or foreign matter.	Lubricate with LAW (item 13, WP 0023 00) through fitting in handle and turn it to the different settings. Notify unit maintenance if it cannot be corrected.
3. SHOCK ABSORBER BINDS OR WONT RETURN.	<ol style="list-style-type: none"> 1. Extend shocks and check for dirt or grit. 2. Check for damage (bent rod, etc.) 	Clean thoroughly. Notify unit maintenance.
4. SHOCK ABSORBER RETURNS TOO FAST.	Extend shocks and release.	Notify unit maintenance.
5. COLLAR AND KNOB WONT CLOSE PROPERLY.	<ol style="list-style-type: none"> 1. Check for dirt or grit. 2. Check for stripped threads or damaged collar. 	Clean thoroughly. Lubricate threads with GPL oil (item 12, WP 0023 00). Notify unit maintenance.
6. BIPOD WILL NOT TRAVERSE PROPERLY.	<ol style="list-style-type: none"> 1. Check for dirt or grit. 2. Check for binding or dents in housing. 3. Check for excessive backlash (1/8 turn or greater). 	Clean thoroughly and lubricate. Notify unit maintenance. Notify unit maintenance.
7. LEFT LEG BINDS.	1. Check for travel limit.	Center fine cross level mechanism and readjust plain wing nut.

Table 1. Troubleshooting Procedures - Continued.

MALFUNCTION	TEST OR INSPECTION	CORRECTIVE ACTION
7. LEFT LEG BINDS - Continued.	2. Check for dirt or grit. 3. Check legs for damage.	Clean thoroughly and lubricate. Notify unit maintenance.
8. BIPOD WILL NOT ELEVATE OR DEPRESS PROPERLY.	1. Check for dirt or grit. 2. Check for damage (bent spindle, etc.). 3. Check for excessive backlash (1/8 turn or greater).	Clean thoroughly. Notify unit maintenance. Notify unit maintenance.
9. BASEPLATE LATCH WONT LATCH (M8).	1. Check for dirt or grit. 2. Check for broken or damaged parts.	Clean thoroughly and lubricate. Notify unit maintenance.
10. LOCKING CAP BINDS (M7 BASEPLATE).	1. Check for dirt or grit. 2. Check for bends or dents in locking cap.	Clean thoroughly and lubricate. Notify unit maintenance.
11. SIGHT UNIT CON- TROLS DO NOT OPERATE.	1. Check to see if locking knobs are tightened. 2. Check for dirt or grit.	Loosen locking knobs. Clean thoroughly. If controls do not operate, notify unit maintenance.

Table 1. Troubleshooting Procedures - Continued.

MALFUNCTION	TEST OR INSPECTION	CORRECTIVE ACTION
<p>12. NO OR LOW ILLUMINATION IN SIGHT UNIT, RANGE INDICATOR ASSEMBLY, OR AIMING POST LIGHTS.</p> <div style="text-align: center;">  <p>WARNING</p> <p>Take care in handling mortar components which contain radioactive tritium H₃. These components are the range indicator assembly, the sight units M64/M64A1, and the aiming post lights M58/M59. If damage occurs, refer to WARNING information in the front of this manual for special handling instructions.</p> </div>	<ol style="list-style-type: none"> 1. Check for broken or cracked vials. 2. Check index arrows and lenses for damage, 	<p>Notify RPO immediately if damaged.</p> <p>Notify RPO immediately if damaged.</p>
<p>13. SIGHT UNIT WONT ATTACH AND LOCK TO BIPOD.</p>	<ol style="list-style-type: none"> 1. Check dovetail bracket on bipod and dovetail on sight unit for nicks and burrs. 2. Check dovetail bracket for paint. 3. Check for broken or bent dovetail on sight unit. 	<p>Notify unit maintenance.</p> <p>Remove paint. Be careful not to scratch or nick metal surfaces.</p> <p>Notify unit maintenance.</p>

Table 1. Troubleshooting Procedures - Continued.

MALFUNCTION	TEST OR INSPECTION	CORRECTIVE ACTION
<p>14. POOR VISIBILITY IN SIGHT UNIT LENSES.</p>	<p style="text-align: center;">NOTE</p> <p>If lenses are cracked or broken, the illumination element may be damaged. Refer to WARNING information in the front of this manual for special handling instructions.</p> <ol style="list-style-type: none"> 1. Check lenses for cracks or breaks. 2. Check lenses for moisture. 	<p>Notify unit maintenance.</p> <p>Place sight unit in a warm area to see if moisture clears. Do not apply heat directly to sight unit lenses.</p>

CHAPTER 4

MAINTENANCE INSTRUCTIONS FOR THE M224 60-MM MORTAR

**PREVENTIVE MAINTENANCE CHECKS AND SERVICES (PMCS),
INCLUDING LUBRICATION INSTRUCTIONS**

0017 00

THIS WORK PACKAGE COVERS:

Introduction, Lubrication Instructions, Lubrication Chart, PMCS Procedures

INTRODUCTION

Preventive Maintenance Checks and Services must be performed by the operator to be sure the 60mm mortar will operate properly. Always keep in mind the WARNINGS and CAUTIONS before and during operation. A WARNING means someone could be hurt. A CAUTION means equipment could be damaged. If your equipment fails to operate, troubleshoot. Report any deficiencies using the proper forms. See DA PAM 738-750.

The INTERVAL column tells you when to do the check or service in the PROCEDURE column. BEFORE checks and services are performed prior to the mortar leaving its containment area or performing its mission. DURING checks begin when the mortar is being used and AFTER checks and services begin when the mortar is taken out of its mission mode or returned to its containment area.

The ITEM TO BE CHECKED OR SERVICED column tells you the component of the mortar to be checked. The amount of time required is indicated in the MAN-HOUR column.

When recording results of PMCS, entries in the PMCS ITEM NO. column will be used for the TM Item No. column on DA Form 2404, Equipment Inspection and Maintenance Worksheet.

The EQUIPMENT NOT READY/AVAILABLE IF column indicates deficiencies which must be corrected before you can operate the 60mm mortar.

Perform weekly as well as before operation PMCS if:

- (1) You are the assigned operator and have not used the item since the last weekly.
- (2) You are operating the item for the first time.

**PREVENTIVE MAINTENANCE CHECKS AND SERVICES (PMCS),
INCLUDING LUBRICATION INSTRUCTIONS - Continued**

0017 00

LUBRICATION INSTRUCTIONS

Lubrication instructions throughout the PMCS table are mandatory.

General purpose lubricating oil (GPL) (item 12, WP 0023 00) is the preferred lubricant. However, rifle bore cleaning compound (RBC) (item 7, WP 0023 00) and weapon lubricating oil (LAW) (item 13, WP 0023 00) are acceptable substitutes. LAW will be used for continuous subzero environments.

Intervals are based on usual operating conditions. For unusual operating conditions, lubricate as instructed in chapter 2, WP 0014 00. When the weapon is not being used, extend the intervals if proper lubrication procedures have been followed.

Clean fittings before lubricating. Clean parts with solvent cleaning compound (item 8, WP 0023 00). Dry before lubricating.

See FM 9-207 for lubrication in arctic conditions.

LUBRICATION CHART

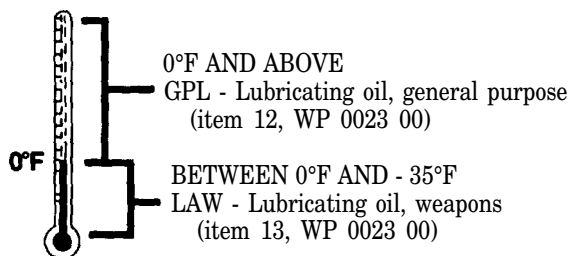

**PREVENTIVE MAINTENANCE CHECKS AND SERVICES (PMCS),
INCLUDING LUBRICATION INSTRUCTIONS - Continued**

0017 00

PMCS PROCEDURES

INITIAL SETUP:

Maintenance Level

Operator

Materials/Parts

- Abrasive cloth (item 9, WP 0023 00)
- Cleaning tool brush (item 4, WP 0023 00)
- General purpose lubricating oil (GPL) (item 12, WP 0023 00)
- Lens paper (item 14, WP 0023 00)
- Optical lens cleaning compound (item 6, WP 0023 00)
- Pressure sensitive adhesive tape (item 17, WP 0023 00)
- Rifle bore cleaning compound (RBC) (item 7, WP 0023 00)
- Weapon lubricating oil (LAW) (item 13, WP 0023 00)
- Wiping rag (item 16, WP 0023 00)

References

- AR 190-11
- DA Form 2408-4
- NAVMC 10558A
- TM 9-1000-202-14

Table 1. Preventive Maintenance Checks and Services for M224 60-mm Mortar.

ITEM NO.	INTERVAL	MAN-HOUR	ITEM TO BE CHECKED OR SERVICED	PROCEDURE	EQUIPMENT NOT READY/ AVAILABLE IF:
1	Before		DA Form 2408-4; NAVMC 10558A (USMC only)	Check if your weapon has been borescoped and pullover gaged within the past 180 days. Borescope every 100 rounds when firing subcaliber training rounds.	1. Weapon has not been borescoped or pullover gaged within 180 days. See TM 9-1000-202-14. Weapon has not been borescoped every 100 rounds when firing subcaliber training rounds.

PREVENTIVE MAINTENANCE CHECKS AND SERVICES (PMCS),
INCLUDING LUBRICATION INSTRUCTIONS - Continued

0017 00

Table 1. Preventive Maintenance Checks and Services for M224 60-mm Mortar -
Continued.

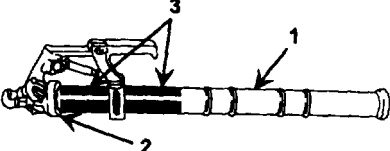
ITEM NO.	INTERVAL	MAN-HOUR	ITEM TO BE CHECKED OR SERVICED	PROCEDURE	EQUIPMENT NOT READY/ AVAILABLE IF:
1 (Cont)	Before (Cont)		DA Form 2408-4; NAVMC 10558A (USMC only) (Cont)		2. After bore diameter reaches 2.402 inches or after 10,000 rounds fired, weapon has not been borescoped every 1,000 additional rounds
2	Before		60-mm Mortar Cannon, M225	 <p>1. Check for foreign matter in cannon tube (1). Wipe bore dry. Lubricate all exterior unpainted surfaces and parts with light coat of GPL (item 12, WP 0023 00). Remove light surface rust with abrasive cloth (item 9, WP 0023 00).</p> <p>2. Look for bulges, dents, cracks, missing or damaged parts, or evidence of gas leakage around breech cap (2) Check bore for rust. Check cooling fins (3) for cracked, bent, or broken fins. Remove dust and dirt from cooling fins.</p>	Tube has bulges, dents, cracks, missing or damaged parts, or evidence of gas leakage (discoloration) around breech cap. Cooling fins are cracked, bent, or broken.

PREVENTIVE MAINTENANCE CHECKS AND SERVICES (PMCS),
INCLUDING LUBRICATION INSTRUCTIONS - Continued

0017 00

Table 1. Preventive Maintenance Checks and Services for M224 60 mm Mortar - continued.

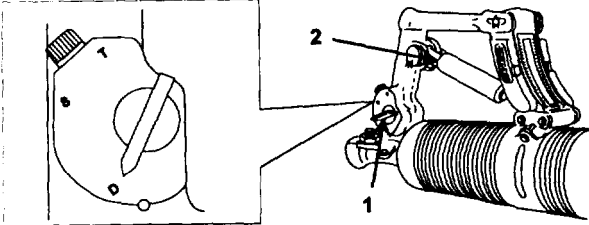
ITEM NO.	INTERVAL	MAN-HOUR	ITEM TO BE CHECKED OR SERVICED	PROCEDURE	EQUIPMENT NOT READY/AVAILABLE IF:		
3	Before		Handle and Firing Mechanism	<p style="text-align: center;">WARNING</p> <p>Take care in handling mortar components which contain radioactive tritium H₃. These components are the range indicator assembly, the sight units M64/M64A1, and the aiming post lights M58/M59. If damage occurs, refer to WARNING information in the front of this manual for special handling instructions.</p> <div style="display: flex; justify-content: space-around; align-items: center;">   </div> <p style="text-align: center;">CAUTION</p> <p>Excessive dry firing will prematurely wear out sear.</p> <table border="1" style="width: 100%; border-collapse: collapse;"> <tr> <td style="width: 50%; padding: 5px;"> <p>1. Place firing selector (1) at T, S, and D and check safety by squeezing the trigger (2). Trigger should not fire mortar with firing selector at S or D. Trigger should click loudly with firing selector at T.</p> </td> <td style="width: 50%; padding: 5px;"> <p>Trigger fires when firing selector is in S or D or will not fire when firing selector is at T. Selector lever will not rotate easily through positions T, S, and D.</p> </td> </tr> </table>	<p>1. Place firing selector (1) at T, S, and D and check safety by squeezing the trigger (2). Trigger should not fire mortar with firing selector at S or D. Trigger should click loudly with firing selector at T.</p>	<p>Trigger fires when firing selector is in S or D or will not fire when firing selector is at T. Selector lever will not rotate easily through positions T, S, and D.</p>	
<p>1. Place firing selector (1) at T, S, and D and check safety by squeezing the trigger (2). Trigger should not fire mortar with firing selector at S or D. Trigger should click loudly with firing selector at T.</p>	<p>Trigger fires when firing selector is in S or D or will not fire when firing selector is at T. Selector lever will not rotate easily through positions T, S, and D.</p>						

**PREVENTIVE MAINTENANCE CHECKS AND SERVICES (PMCS),
INCLUDING LUBRICATION INSTRUCTIONS - Continued**

0017 00

**Table 1. Preventive Maintenance Checks and Services for M224 60 mm Mortar -
Continued.**

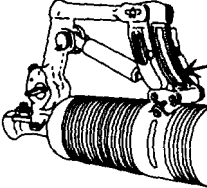
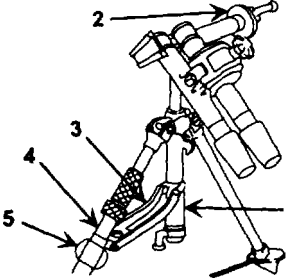
ITEM NO.	INTERVAL	MAN-HOUR	ITEM TO BE CHECKED OR SERVICED	PROCEDURE	EQUIPMENT NOT READY/ AVAILABLE IF:
3 (Cont)	Before (Cont)		Handle and Firing Mechanism (Cont)	 <p data-bbox="687 752 981 832">2. Check for illumination of range indicator assembly (3) in darkened area.</p>	No illumination.
4	Before		60-mm Mortar Bipod, M170	 <p data-bbox="687 1170 967 1395">1. Check for smooth operation of elevating mechanism (1), traversing mechanism (2), and cross-leveling mechanism (3). Leg (4) must move in and out smoothly with plain wing nut (5) loosened.</p>	Elevating mechanism, traversing mechanism, and/or cross-leveling mechanism is not working. Legs bind. Plain wing nut will not lock. Backlash exceeds 1/8 turn in traversing mechanism or elevating mechanism.

PREVENTIVE MAINTENANCE CHECKS AND SERVICES (PMCS),
INCLUDING LUBRICATION INSTRUCTIONS - Continued

0017 00

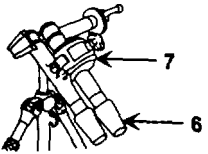
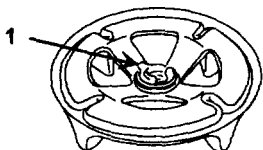
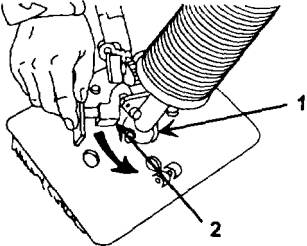

Table 1. Preventive Maintenance Checks and Services for M224 60 mm Mortar -
Continued.

ITEM NO.	INTERVAL	MAN-HOUR	ITEM TO BE RECKED OR SERVICED	PROCEDURE	EQUIPMENT NOT READY/ AVAILABLE IF:
5	Before		Mortar Baseplate, M7	 <p>2. Extend shock absorbers (6); they must return smoothly, without binding, to original position when released. Check that collar (7) locks securely.</p>  <p>Check for cracks or breaks. Check locking cap (1) for smooth 360° rotation.</p>	<p>Shock absorbers will not return without binding. Collar inoperable</p> <p>Baseplate cracked or broken. Locking cap does not rotate 360°.</p>

**PREVENTIVE MAINTENANCE CHECKS AND SERVICES (PMCS),
INCLUDING LUBRICATION INSTRUCTIONS - Continued**

0017 00

**Table 1. Preventive Maintenance Checks and Services for M224 60 mm Mortar -
Continued.**

ITEM NO.	INTERVAL	MAN-HOUR	ITEM TO BE CHECKED OR SERVICED	PROCEDURE	EQUIPMENT NOT READY/ AVAILABLE IF:
6	Before		Mortar Baseplate, M8	 <p data-bbox="687 864 967 1056">Insert basecap (1) of cannon into socket of baseplate. Close latch (2). Check that latch pin seats and locks. Check for positive retention of baseplate on cannon.</p>	Latch is broken or baseplate comes off cannon when latch is locked.
7	Before		Sight Unit M64/M64A1	<p data-bbox="722 1170 883 1196" style="text-align: center;">WARNING</p> <div style="display: flex; align-items: center;">  <p data-bbox="460 1215 1139 1380">Take care in handling mortar components which contain radioactive tritium H₃. These components are the range indicator assembly, the sight units M64/M64A1, and the aiming post lights M58/M59. If damage occurs, refer to WARNING information in the front of this manual for special handling instructions.</p> </div>	

**PREVENTIVE MAINTENANCE CHECKS AND SERVICES (PMCS),
INCLUDING LUBRICATION INSTRUCTIONS - Continued**

0017 00

**Table 1. Preventive Maintenance Checks and Services for M224 60 mm Mortar -
Continued.**

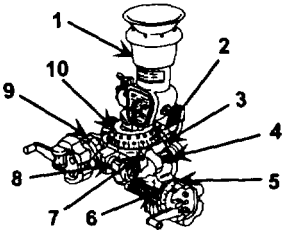
ITEM NO.	INTERVAL	MAN-HOUR	ITEM TO BE CHECKED OR SERVICED	PROCEDURE	EQUIPMENT NOT READY/ AVAILABLE IF:
				<ol style="list-style-type: none"> 1. Telescope 2. Coarse elevation scale 3. Coarse elevation scale arrow 4. Cross-level vial 5. Fine elevation scale 6. Fine elevation index arrow 7. Coarse azimuth (deflection) index arrow 8. Elevation vial 9. Fine azimuth (deflection) scale 10. Coarse azimuth (deflection) scale <p>1. Ten items on the sight unit are radioactively illuminated. Whenever you get a new sight unit, check the ten points in a darkened area. If any of the ten items are not illuminated, return the sight unit as directed by WARNING paragraph B in the front of this manual.</p>	<p>Any of the ten items is not illuminated.</p>

PREVENTIVE MAINTENANCE CHECKS AND SERVICES (PMCS),
INCLUDING LUBRICATION INSTRUCTIONS - Continued

0017 00

Table 1. Preventive Maintenance Checks and Services for M224 60 mm Mortar -
Continued.

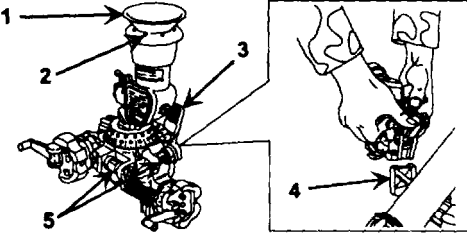
ITEM NO.	INTERVAL	MAN-HOUR	ITEM TO BE CHECKED OR SERVICED	PROCEDURE	EQUIPMENT NOT READY/ AVAILABLE IF:
7 (Cont)	Before (Cont)		Sight Unit M64/M64A1 (Cont)	 <p>2. Look through eyepiece (1). Check for dirt, cracks, or fogging. Check eyeshield vent holes (2) for dirt.</p> <p>3. Check that latching lever (3) secures sight unit mount to dovetail (4).</p> <p>4. Check that bubbles in level vials (5) will move and vials are not cracked or loose in mounting. Check that vial covers rotate freely.</p>	<p>Target image is obstructed or reticle not visible.</p> <p>Sight unit mount will not fit in dovetail on bipod.</p> <p>Vials are broken Vial covers will not rotate.</p>

PREVENTIVE MAINTENANCE CHECKS AND SERVICES (PMCS),
INCLUDING LUBRICATION INSTRUCTIONS - Continued

0017 00

Table 1. Preventive Maintenance Checks and Services for M224 60 mm Mortar - Continued.

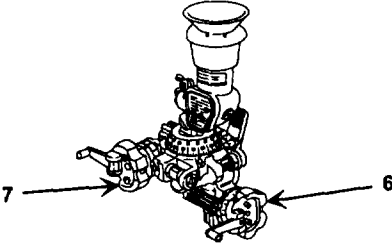
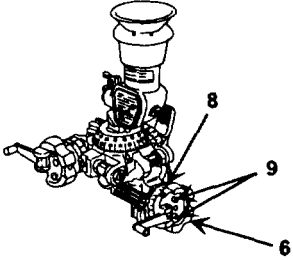
ITEM NO.	INTERVAL	MAN-HOUR	ITEM TO BE CHECKED OR SERVICED	PROCEDURE	EQUIPMENT NOT READY/ AVAILABLE IF:
				 <p>5. Check elevation knob (6) and azimuth (deflection) knob (7) for smooth operation (no binding). Check that backlash on knobs (6 and 7) doesn't exceed 0.5 mils.</p>	<p>1. Knobs won't turn.</p> <p>2. Azimuth or elevation knob slips when locking knobs are tightened.</p>
				 <p>6. Check that fine elevation scale (8) of elevation knob (6) slips only when screws (9) are loosened.</p>	<p>1. Scale not readable.</p> <p>2. Scale slips when in locked position.</p>

**PREVENTIVE MAINTENANCE CHECKS AND SERVICES (PMCS),
INCLUDING LUBRICATION INSTRUCTIONS - Continued**

0017 00

**Table 1. Preventive Maintenance Checks and Services for M224 60 mm Mortar -
continued.**

ITEM NO.	INTERVAL	MAN-HOUR	ITEM TO BE CHECKED OR SERVICED	PROCEDURE	EQUIPMENT NOT READY/ AVAILABLE IF:
8	Before			<p style="text-align: center;">NOTE</p> <p>60mm Mortar can be fired only in the hand-held mode if the M115 boresight is not ready/available.</p> <ol style="list-style-type: none"> 1. Inspect lens for dirt, cracks, or fogging. 2. Check that level vial bubbles will move and vials are not broken or loose in mounting. 3. Check that mounting surfaces are free of nicks and burrs. 	<p>Image is obstructed.</p> <p>Bubbles won't move. Vials broken or loose in mounting.</p> <p>Nicks and burrs on mounting surfaces.</p>
9	Before		Aiming Post Lights, M58 or M59	<p style="text-align: center;">WARNING</p> <p>Take care in handling mortar components which contain radioactive tritium H₃. These components are the range indicator assembly, the sight units M64/M64A1, and the aiming post lights M58/M59. If damage occurs, refer to WARNING information in the front of this manual for special handling instructions.</p>	



**PREVENTIVE MAINTENANCE CHECKS AND SERVICES (PMCS),
INCLUDING LUBRICATION INSTRUCTIONS - Continued**

0017 00

**Table 1. Preventive Maintenance Checks and Services for M224 60 mm Mortar -
Continued.**

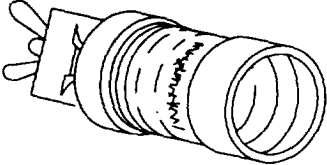
ITEM NO.	INTERVAL	MAN-HOUR	ITEM TO BE CHECKED OR SERVICED	PROCEDURE	EQUIPMENT NOT READY/ AVAILABLE IF:
10	During		60-mm Mortar Cannon, M225	 <ol style="list-style-type: none"> 1. Wipe with clean dry cloth prior to use. 2. Check for illumination in darkened area. 3. Check for missing or damaged radiation warning data plate, or other parts. 4. Check for evidence of tampering (aiming post lights are factory sealed and no disassembly is authorized or required). <p>Cannon bore is required to be dry swab cleaned at the end of each fire mission, or after 10 rounds fired (approximately).</p>	<p>No illumination.</p> <p>Missing or damaged radiation warning, data plate, or other parts.</p> <p>Evidence of tampering.</p>

**PREVENTIVE MAINTENANCE CHECKS AND SERVICES (PMCS),
INCLUDING LUBRICATION INSTRUCTIONS - Continued**

0017 00

**Table 1. Preventive Maintenance Checks and Services for M224 60 mm Mortar -
Continued.**

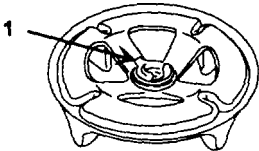
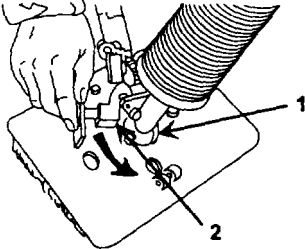
ITEM NO.	INTERVAL	MAN-HOUR	ITEM TO BE CHECKED OR SERVICED	PROCEDURE	EQUIPMENT NOT READY/ AVAILABLE IF:
11	During		Mortar Baseplate, M7	 <p data-bbox="680 846 970 930">Check for cracks or breaks. Check locking cap (1) for smooth 360° rotation.</p>	Baseplate cracked or broken. Locking cap does not rotate 360°.
12	During		Mortar Baseplate, M8	 <p data-bbox="680 1408 956 1603">Insert basecap (1) of cannon into socket of baseplate. Close latch (2). Check that latch pin seats and locks. Check for positive retention of baseplate on cannon.</p>	Latch is broken or baseplate comes off cannon when latch is locked.

PREVENTIVE MAINTENANCE CHECKS AND SERVICES (PMCS),
INCLUDING LUBRICATION INSTRUCTIONS - Continued

0017 00

Table 1. Preventive Maintenance Checks and Services for M224 60 mm Mortar -
Continued.

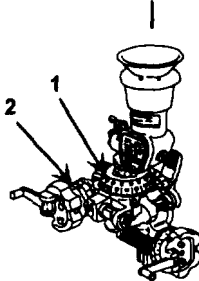
ITEM NO.	INTERVAL	MAN-HOUR	ITEM TO BE CHECKED OR SERVICED	PROCEDURE	EQUIPMENT NOT READY/AVAILABLE IF:
13	During		Sight Unit M64/M64A1	<p style="text-align: center;">WARNING</p> <div style="display: flex; align-items: center;">  <p>Take care in handling mortar components which contain radioactive tritium H₃. These components are the range indicator assembly, the sight units M64/M64A1, and the aiming post lights M58/M59. If damage occurs, refer to WARNING information in the front of this manual for special handling instructions.</p> </div> <div style="text-align: right; margin-top: 100px;">  <p>Check coarse azimuth (deflection) scale (1) and fine azimuth (deflection) scale (2) to ensure that scales rotate freely when depressed and return to position under spring tension when released.</p> </div>	<p>Scales slip during firing.</p>

**PREVENTIVE MAINTENANCE CHECKS AND SERVICES (PMCS),
INCLUDING LUBRICATION INSTRUCTIONS - Continued**

0017 00

**Table 1. Preventive Maintenance Checks and Services for M224 60 mm Mortar -
Continued.**

ITEM NO.	INTERVAL	MAN-HOUR	ITEM TO BE CHECKED OR SERVICED	PROCEDURE	EQUIPMENT NOT BEADY/ AVAILABLE IF:
14	After		DA Form 2408-4; NAVMC 10558A (USMC only)	Update DA Form 2408-4 to reflect day's tiring.	After bore diameter reaches 2.402 inches or after 10,000 rounds fired, weapon has not been borescoped every 1,000 additional rounds.
15	After		60-mm Mortar cannon, M225	<p>1. Immediately after firing and on the next two days, thoroughly clean with RBC (item 7, WP 0023 00), making sure that all surfaces are well coated. Do not wipe dry. On third day after firing, clean with RBC. Wipe dry and lightly coat with GPL oil (item 12, WP 0023 00).</p> <p>2. Lubricate all unpainted surfaces and parts with light coat of GPL oil (item 12, WP 0023 00). Remove light surface rust with abrasive cloth (item 9, WP 0023 00).</p>	

**PREVENTIVE MAINTENANCE CHECKS AND SERVICES (PMCS),
INCLUDING LUBRICATION INSTRUCTIONS - Continued**

0017 00

**Table 1. Preventive Maintenance Checks and Services for M224 60 mm Mortar -
Continued.**

ITEM NO.	INTERVAL	MAN-HOUR	ITEM TO BE CHECKED OR SERVICED	PROCEDURE	EQUIPMENT NOT READY/ AVAILABLE IF:
16	After		60-mm Mortar Bipod, M170	Move traversing mechanism through full range of movement and lubricate repainted surface with light coat of GPL oil (item 12, WP 0023 00). Fully Extend left leg and lubricate unpainted surface with light coat of GPL oil.	
17	After		Mortar Baseplate, M7	Lubricate all unpainted surfaces and parts with light coat of GPL oil (item 12, WP 0023 00). Remove light surface rust with abrasive cloth (item 9, WP 0023 00).	
18	After		Mortar Baseplate, M8	Lubricate all unpainted surfaces and parts with light coat of GPL oil (item 12, WP 0023 00). Remove light surface rust with abrasive cloth (item 9, WP 0023 00).	

**PREVENTIVE MAINTENANCE CHECKS AND SERVICES (PMCS),
INCLUDING LUBRICATION INSTRUCTIONS - Continued**

0017 00

**Table 1. Preventive Maintenance Checks and Services for M224 60 mm Mortar -
Continued.**

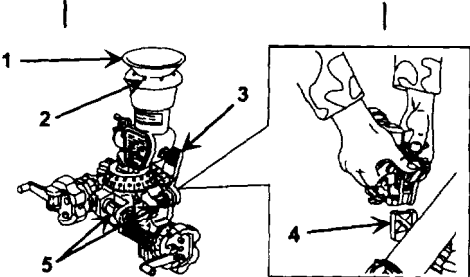
ITEM NO.	INTERVAL	MAN-HOUR	ITEM TO BE CHECKED OR SERVICED	PROCEDURE	EQUIPMENT NOT READY/ AVAILABLE IF:
19	After		Sight Unit M64/M64A1	<p style="text-align: center;">WARNING</p> <div style="display: flex; align-items: center;">  <div> <p>Take care in handling mortar components which contain radioactive tritium H₃. These components are the range indicator assembly, the sight units M64/M64A1, and the aiming post lights M58/M59. If damage occurs, refer to WARNING information in the front of this manual for special handling instructions.</p> </div> </div> <div style="text-align: center; margin: 20px 0;">  </div> <div style="display: flex; justify-content: space-between;"> <div style="width: 45%;"> <p>1. Look through eyepiece (1). Check for dirt, cracks, or fogging. Check eyeshield vent holes (2) for dirt.</p> <p>2. Check that latching lever (3) secures sight unit mount to dovetail (4).</p> <p>3. Check that bubbles in level vials (5) will move and vials are not cracked or loose in mounting.</p> </div> <div style="width: 45%;"> <p>Target image is obstructed or reticle not visible.</p> <p>Sight unit mount will not fit in dovetail on bipod.</p> <p>Vials are broken.</p> </div> </div>	

PREVENTIVE MAINTENANCE CHECKS AND SERVICES (PMCS),
INCLUDING LUBRICATION INSTRUCTIONS - Continued

0017 00

Table 1. Preventive Maintenance Checks and Services for M224 60 mm Mortar -
Continued.

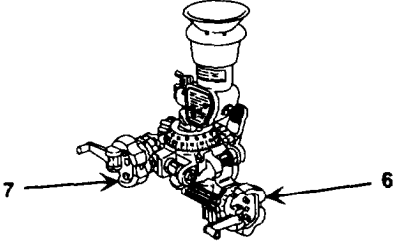
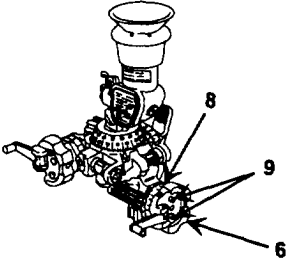
ITEM NO.	INTERVAL	MAN-HOUR	ITEM TO BE CHECKED OR SERVICED	PROCEDURE	EQUIPMENT NOT READY/ AVAILABLE IF:
				 <p data-bbox="701 868 998 1061">4. Check elevation knob (6) and azimuth (deflection) knob (7) for smooth operation (no binding). Check that backlash on knobs (6 and 7) doesn't exceed 0.5 mils.</p>	<p data-bbox="1020 868 1188 1089">1. Knobs won't turn. 2. Azimuth or elevation knob slips when locking knobs are tightened.</p>
				 <p data-bbox="701 1446 1002 1558">5. Check that fine elevation scale (8) of elevation knob (6) slips only when screws (9) are loosened.</p>	<p data-bbox="1020 1446 1185 1615">1. Scale not readable. 2. Scale slips when in locked position.</p>

**PREVENTIVE MAINTENANCE CHECKS AND SERVICES (PMCS),
INCLUDING LUBRICATION INSTRUCTIONS - Continued**

0017 00

**Table 1. Preventive Maintenance Checks and Services for M224 60 mm Mortar -
Continued.**

ITEM NO.	INTERVAL	MAN-HOUR	ITEM TO BE CHECKED OR SERVICED	PROCEDURE	EQUIPMENT NOT READY/ AVAILABLE IF:
19 (Cont)	After (Cont)		Sight Unit M64/M64A1 (Cont)	6. Do not lubricate the sight unit. Wipe dry, using wiping rag (item 16, WP 0023 00). Clean lens with optical lens cleaning compound (item 6, WP 0023 00) and lens paper (item 14, WP 0023 00). Coat unpainted metal surface with GPL oil (item 12, WP 0023 00). After cleaning, cover exposed lens with two thicknesses of lens paper (item 14, WP 0023 00) and secure with pressure sensitive adhesive tape (item 17, WP 0023 00). Store in clean and dry rack, cabinet, or container that meets the security requirements of AR 190-11.	
20	After		Boresight	Wipe with clean dry cloth prior to storage.	
21	After		Aiming Post Lights, M58 or M59	Wipe with clean dry cloth prior to storage.	
22	Weekly		60-mm Mor- tar cannon, M225	1. Clean with RBC (item 7, WP 0023 00). Wipe dry and lubricate all unpainted surfaces and parts with light coat of GPL oil (item 12, WP 0023 00) when weapon is not being fired. Remove light surface rust with abrasive cloth (item 9, WP 0023 00).	

**PREVENTIVE MAINTENANCE CHECKS AND SERVICES (PMCS),
INCLUDING LUBRICATION INSTRUCTIONS - Continued**

0017 00

**Table 1. Preventive Maintenance Checks and Services for M224 60mm Mortar -
Continued.**

ITEM NO.	INTERVAL	MAN-HOUR	ITEM TO BE CHECKED OR SERVICED	PROCEDURE	EQUIPMENT NOT READY/ AVAILABLE IF:
23	Weekly		Handle and Firing Mechanism	<p>2. Weekly, or as needed, use cleaning tool brush (item 4, WP 0023 00) to carefully clean cooling fins on cannon to assure maximum heat transfer. Do not allow dirt or foreign matter to build up on the cooling fins.</p> <p>Use LAW (item 13, WP 0023 00) only in the handle lubrication fitting and on the firing selector.</p>	
24	Weekly		60-mm Mortar Bipod M170	<p>1. Lubricate all unpainted surfaces and parts with light coat of GPL oil (item 12, WP 0023 00). Remove light surface rust with abrasive cloth (item 9, WP 0023 00).</p> <p>2. Move traversing mechanism through full range of movement and lubricate unpainted surface with light coat of GPL oil (item 12, WP 0023 00). Fully extend left leg and lubricate unpainted surface with light coat of GPL oil.</p>	

**PREVENTIVE MAINTENANCE CHECKS AND SERVICES (PMCS),
INCLUDING LUBRICATION INSTRUCTIONS - Continued**

0017 00

**Table 1. Preventive Maintenance Checks and Services for M224 60 mm Mortar -
Continued.**

ITEM NO.	INTERVAL	MAN-HOUR	ITEM TO BE CHECKED OR SERVICED	PROCEDURE	EQUIPMENT NOT READY/ AVAILABLE IF:
25	Weekly		Mortar Base-plate, M7	Lubricate all unpainted surfaces and parts with light coat of GPL oil (item 12, WP 0023 00). Remove light surface rust with abrasive cloth (item 9, WP 0023 00).	
26	Weekly		Mortar Base-plate, M8	Lubricate all unpainted surfaces and parts with light coat of GPL oil (item 12, WP 0023 00). Remove light surface rust with abrasive cloth (item 9, WP 0023 00).	
27	Semi-annually		60-mm Mortar Bipod, M170	Send bipod to field maintenance for servicing of collar shock absorber assembly, elevating mechanism, and traversing mechanism.	

END OF TASK

60MM, M224 LIGHTWEIGHT COMPANY MORTAR MAINTENANCE

0018 00

THIS WORK PACKAGE COVERS:

60mm Mortar, M224

INITIAL SETUP:

Maintenance Level

Operator

Materials/Parts

Paint brush (item 5, WP 0023 00)

Polyurethane coating (item 15, WP 0023 00)

Synthetic thinner (item 18, WP 0023 00)

References

WP 0017 00

WP 0019 00

60MM MORTAR, M224

Operator maintenance is limited to inspecting and servicing components as outlined in the following instructions:

- 1 PMCS, including lubrication instructions (WP 0017 00).
- 2 Care and cleaning of optical parts (WP 0019 00).

WARNING

Paint thinners are flammable and toxic. Do not use near an open flame.
Use only in a well ventilated area.

The operator may also touch up the paint using polyurethane coating (item 15, WP 0023 00), paint brush (item 5, WP 0023 00), and synthetic thinner (item 18, WP 0023 00).

END OF TASK

CARE AND CLEANING OF OPTICAL PARTS

0019 00

THIS WORK PACKAGE COVERS:

Wiping, Cleaning, Cold Weather Cleaning, Removal of Moisture

INITIAL SETUP:

Maintenance Level

Operator

Materials/Parts

Alcohol (item 1, WP 0023 00)

Artist brush (item 3, WP 0023 00)

Lens paper (item 14, WP 0023 00)

CAUTION

Keep exposed surfaces of lenses and other parts clean and dry to prevent or retard corrosion of metal and etching of surfaces of glass.

Never use polishing liquids, pastes, or abrasives to polish lenses and windows.

WIPING

1. Use only lens paper (item 14, WP 0023 00), especially intended for cleaning optical glass.
2. Do not use cleaning cloths on optical surfaces.

CLEANING

1. Keep optical parts free from oil and grease.
2. Do not touch lenses or windows with bare fingers.
3. Apply alcohol (item 1, WP 0023 00) with lens paper (item 14, WP 0023 00). Wipe gently with clean lens paper to remove oil or grease from optical surfaces.

COLD WEATHER CLEANING

1. Clean optical surfaces with lens paper (item 14, WP 0023 00) moistened with alcohol (item 1, WP 0023 00).
2. If alcohol is not available, use dry lens paper and artist brush (item 3, WP 0023 00).
3. Wipe gently to avoid scratching or removing coated surface of optics.

REMOVAL OF MOISTURE

1. Condensation may cause moisture to collect on optical parts of instrument when temperature of parts is lower than that of surrounding air.

CAUTION

Do not apply heat directly from concentrated sources. This could cause unequal expansion of parts, leading to damage and inaccurate functioning of optical parts.

2. If moisture from condensation is not excessive, you can remove it by placing instruments in warm place.
3. If moisture from condensation is excessive, notify unit maintenance.

END OF TASK

TM 9-1010-223-10

CHAPTER 5
SUPPORTING INFORMATION

REFERENCES

SCOPE

This work package lists all field manuals, forms, miscellaneous publications, technical manuals, and Marine Corps publications referenced in this manual.

FIELD MANUALS

Basic Cold Weather Manual	FM 31-70
First Aid for Soldiers	FM 21-11
4.2-Inch Mortar, M30	FM 23-92
Mortars	FM 23-90
Northern Operations	FM 31-71
Operation and Maintenance of Ordnance Materiel in Cold - Weather (0° to - 65°F)	FM 9-207

FORMS

Equipment Control Record	DA Form 2408-9
Equipment Inspection and Maintenance Worksheet	DA Form 2404
Equipment Maintenance Log	DA Form 2409
Product Quality Deficiency Report	SF 368
Recommended Changes to Publications and Blank Forms	DA Form 2028
Supply Discrepancy Report	SF 364
Weapon Record Data	DA Form 2408-4

MISCELLANEOUS PUBLICATIONS

Army Medical Department Expendable/Durable Items, Expendable/Durable Items (Except: Medical, Class V, Parts, and Heraldic Items)	CTA 8-100
Functional Users Guide for the Army Maintenance Management System (TAMMS)	CTA 50-970
Ionizing Radiation Protection (Licensing, Control, Transportation, Disposal, and Radiation Safety)	DA PAM 738-750
Notices, Instructions, and Reports to Workers; Inspections	AR 385-11
Physical Security of Arms, Ammunition and Explosives	10CFR Part 19
Policies and Procedures for Firing Ammunition for Training, Target Practice and Combat	AR 190-11
Reporting of Defects and Non-Compliance	AR 385-63
60mm Mortar, M224	10CFR Part 21
Standards for Protection Against Radiation	FT 60-P-1
	10CFR Part 20

REFERENCES - Continued

0020 00

TECHNICAL MANUALS

Army Ammunition Data Sheets for Artillery Ammunition: Guns, Howitzers, Mortars, Recoilless Rifles, Grenade Launchers and Artillery Fuzes	TM 43-0001-28
Destruction Process for Equipment in FSC 1000 - 1095 to Prevent Enemy Use	TM 750-244-7
Evaluation of Cannon Tubes	TM 9-1000-202-14
Operator's and Unit Maintenance Manual (Including Repair Parts and Special Tools List) for Cartridge, 60mm: Target Practice (SR), M766	TM 9-1310-252-12&P
Operator's and Organizational Maintenance Manual Including Repair Parts and Special Tools List for Plotting Board, Indirect Fire, M16/M19 W/E	TM 9-1220-243-12&P
Operator's and Organizational Maintenance Manual Including Repair Parts and Special Tools List for 60-mm Mortar Training Device Sabot (Inert), M3, and 22-mm Subcaliber Practice Cartridge, M744, M745, M746, M747	TM 9-1310-249-12&P

USMC PUBLICATIONS AND FORMS

Consumer-Level Supply Policy Manual	MCO P4400.150
Department of the Navy Physical Security Instruction for Conventional Arms, Ammunition, and Explosives (AA&E)	OPNAVINST 5530.13
Department of the Navy Physical Security and Loss Prevention	OPNAVINST 5530.14
Equipment Record Procedures	TM 4700-15/1
Ground Mishaps Report	MCO 5102.1
Marine Corps Radiation Safety	MCO 5104.3
Product Quality Deficiency Report	MCO 4855.10
Recommended Changes to Technical Publications	NAVMC 10772
Report of Item and Packaging Discrepancies	MCO 4430.3
Reporting of Item and Packaging Discrepancies	SECNAVINST 4355.18
Special Handling Tritium Fire Control	TI-5104-15/2A
TMDE Calibration and Maintenance Procedures	TI-4733-15/1D
Transportation and Travel Record of Transportation Discrepancies	MCO P4610.19
USMC Military Incentives Award Program	MCO 1650.17
Weapons Record Book, Part II - Tube Data	NAVMC Form 10558A

INTRODUCTION

Scope

This work package lists COEI and BII for the M224 mortar to help you inventory items for safe and efficient operation of the equipment.

General

Army: The COEI and BII information is divided into the following lists:

Components of End Item (COEI). This list is for information purposes only and is not authority to requisition replacements. These items are part of the M224 mortar. As part of the end item, these items must be with the end item whenever it is issued or transferred between property accounts. Items of COEI are removed and separately packaged for transportation or shipment only when necessary. Illustrations are furnished to help you find and identify the items.

Basic Issue Items (BII). These essential items are required to place the M224 mortar in operation, operate it, and to do emergency repairs. Although shipped separately packaged, BII must be with the M224 mortar during operation and when it is transferred between property accounts. Listing these items is your authority to request/requisition them for replacement based on authorization of the end item by the TOE/MTOE. Illustrations are furnished to help you find and identify the items.

Marine Corps: The items listed in this work package will be handled by Marine Corps personnel as follows:

Supply System Responsibility. This is a list, in alphabetical sequence, of items that are furnished with and must be turned in with the end item. Any item requiring replacement is the responsibility of the holding organization or using unit.

Collateral Material. This is a list, in alphabetical sequence, of items that are supplied with the initial issue of an end item and are retained by the unit.

5th Echelon Rehabilitation Program. Major items returned under this program will be evacuated under the provision(s) of the applicable Marine Corps Order(s) with items listed under "Supply System Responsibility." Rebuild and replacement under a 5th Echelon rehabilitation program will be limited to these items only. Those items under the heading "Collateral Material" and using unit items shall be held by holding organizations/using units for application to replacement end items.

**COMPONENTS OF END ITEM (COEI) AND BASIC ISSUE ITEMS (BII)
LISTS - Continued**

0021 00

INTRODUCTION - Continued

Explanation of Columns in the COEI List and BII List

Column (1) - Illus Number. Gives you the number of the item illustrated.

Column (2) - National Stock Number (NSN). Identifies the stock number of the item to be used for requisitioning purposes.

Column (3) - Description, CAGEC, and Part Number. Identifies the Federal item name (in all capital letters) followed by a minimum description when needed. The stowage location of COEI and BII is also included in this column. The last line below the description is the CAGEC (Commercial and Government Entity Code) (in parentheses) and the part number.

Column (4) - Usable On Code. When applicable, gives you a code if the item you need is not the same for different models of equipment.

Column (5) - Unit of Measure (U/M). Indicates the physical measurement or count of the item as issued per the National Stock Number shown in column (2).

Column (6) - Qty Rqr. Indicates the quantity required.

**COMPONENTS OF END ITEM (COEI) AND BASIC ISSUE ITEMS (BI)
LISTS - Continued**

0021 00

**COMPONENTS OF END ITEM AND MARINE CORPS SUPPLY SYSTEM RESPONSIBILITY
LIST**

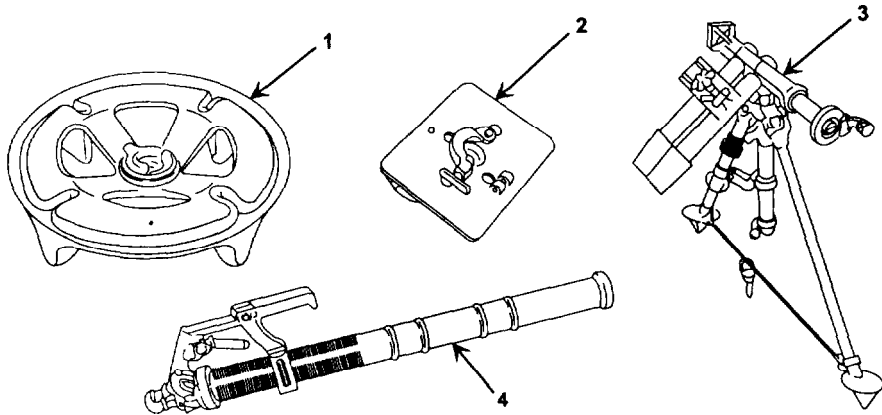

(1) ILLUS NUMBER	(2) NATIONAL STOCK NUMBER	(3) DESCRIPTION, CAGEC, AND PART NUMBER	(4) USABLE IN CODE	(5) U/M	(6) QTY RQR
1	1010-01-043-7504	BASEPLATE, MORTAR, M7 (19206) 11579070		EA	1
2	1010-01-043-4661	BASEPLATE, MORTAR, M8 (19206) 11578990		EA	1
3		BIPOD, 60MM MORTAR, M170 (19206) 11579090		EA	1
4		CANNON, 60MM MORTAR, M225 (19206) 11579080		EA	1

COMPONENTS OF END ITEM (COEI) AND BASIC ISSUE ITEMS (BII)
LISTS - Continued

0021 00

COMPONENTS OF END ITEM AND MARINE CORPS SUPPLY SYSTEM RESPONSIBILITY
LIST - Continued

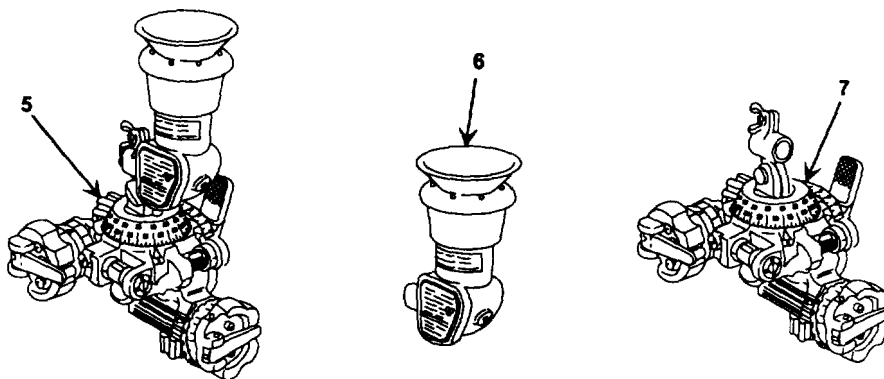

(1) ILLUS NUMBER	(2) NATIONAL STOCK NUMBER	(3) DESCRIPTION, CAGEC, AND PART NUMBER	(4) USABLE ON CODE	(5) U/M	(6) QTY RQR
5	1240-01-379-7953	SIGHT UNIT, M64A1 (19200) 9360168 consists of:		EA	1
6	6650-01-211-3608	TELESCOPE, ELBOW, OPTICAL DEVICE (19200) 9360257		EA	1
7	1240-01-201-8299	MOUNT, TELESCOPE (19200) 9360169		EA	1

COMPONENTS OF END ITEM (COEI) AND BASIC ISSUE ITEMS (BII)
LISTS - Continued

0021 00

COMPONENTS OF END ITEM AND MARINE CORPS SUPPLY SYSTEM RESPONSIBILITY
LIST - Continued

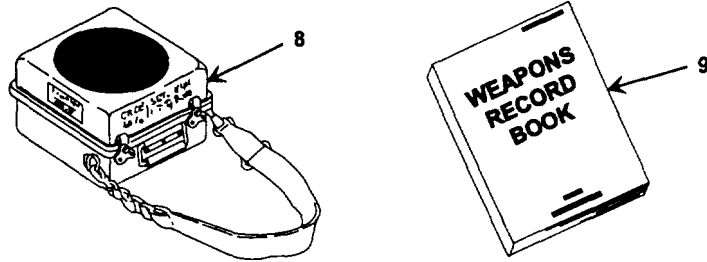

NOTE

These items are Marine Corps Supply System Responsibility items, but are not Army COEI.

(1) ILLUS NUMBER	(2) NATIONAL STOCK NUMBER	(3) DESCRIPTION, CAGEC, AND PART NUMBER	(4) USABLE ON CODE	(5) U/M	(6) QTY RQR
8	1240-01-044-4572	CASE, SIGHT UNIT (19200) 11733760 (USMC ONLY)		EA	1
9	0000-00-005-9811	BOOK, WEAPONS RECORD (19206) 10558A-SD (USMC ONLY)		EA	1

COMPONENTS OF END ITEM (COEI) AND BASIC ISSUE ITEMS (BI)
LISTS - Continued

0021 00

BASIC ISSUE ITEMS AND MARINE CORPS COLLATERAL MATERIAL LIST

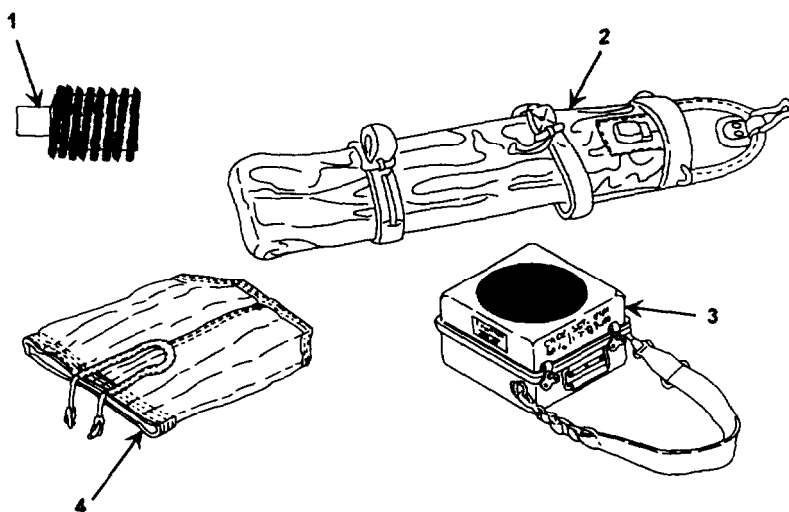

(1) ILLUS NUMBER	(2) NATIONAL STOCK NUMBER	(3) DESCRIPTION, CAGEC, AND PART NUMBER	(4) USABLE IN CODE	(5) U/M	(6) QTY RQR
1	1010-01-044-1867	BRUSH, CLEANING, ARTILLERY (19206) 11579275		EA	1
2	1290-01-043-8288	CASE, AIMING POST (19200) 11733755		EA	1
3	1240-01-044-4572	CASE, SIGHT UNIT (19200) 11733760 (MARINE CORPS SSR)		EA	1
4	1240-01-043-7502	COVER, FIRE CONTROL (19200) 11733753		EA	1

COMPONENTS OF END ITEM (COEI) AND BASIC ISSUE ITEMS (BI)
LISTS - Continued

0021 00

BASIC ISSUE ITEMS AND MARINE CORPS COLLATERAL MATERIAL LIST - Continued

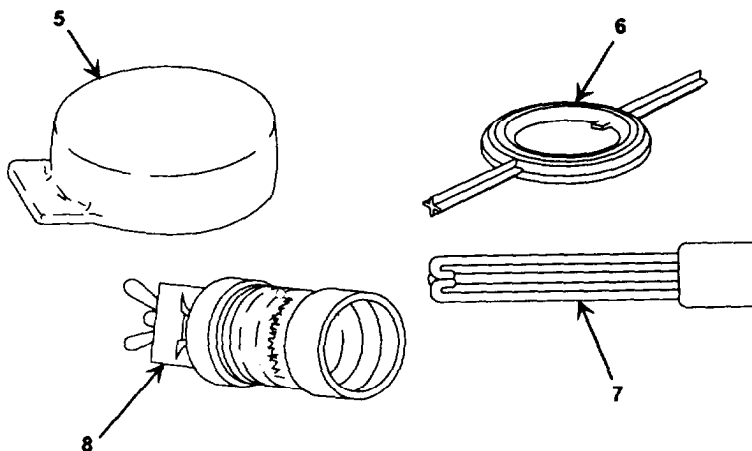

(1) ILLUS NUMBER	(2) NATIONAL STOCK NUMBER	(3) DESCRIPTION, CAGEC, AND PART NUMBER	(4) USABLE ON CODE	(5) U/M	(6) QTY RQR
5	1010-01-048-1420	COVER, GUN MUZZLE (19206) 11579102		EA	1
6	1390-01-326-0675	FUZE SETTER, MTSQ (19200) 12929246		EA	1
7	5340-00-257-1033	HOOK, ARTILLERY, CLEANING (19206) 11578350		EA	1
8	1290-01-443-8389	LIGHT, AIMING POST, M58 (Green) (19200) 12961204		EA	2

COMPONENTS OF END ITEM (COEI) AND BASIC ISSUE ITEMS (BI)
LISTS - Continued

0021 00

BASIC ISSUE ITEMS AND MARINE CORPS COLLATERAL MATERIAL LIST - Continued

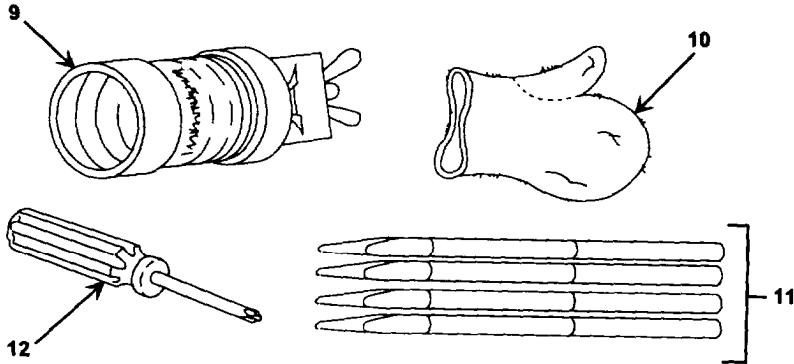

(1) ILLUS NUMBER	(2) NATIONAL STOCK NUMBER	(3) DESCRIPTION, CAGEC, AND PART NUMBER	(4) USABLE ON CODE	(5) U/M	(6) QTY RQR
9	1290-01-443-9344	LIGHT, AIMING POST, M59 (Orange) (19200) 12961205		EA	1
10	8415-01-092-0039	MITTEN, HEAT PROTECTIVE (81349) MIL-M-11199F		EA	1
11	1290-01-046-8320	POST, AIMING, M14 (19200) 11736201		EA	8
12	5120-00-820-2995	SCREWDRIVER, CROSS TIP (81348) GGG-S-121		EA	1

COMPONENTS OF END ITEM (COEI) AND BASIC ISSUE ITEMS (BII)
LISTS - Continued

0021 00

BASIC ISSUE ITEMS AND MARINE CORPS COLLATERAL MATERIAL LIST - Continued

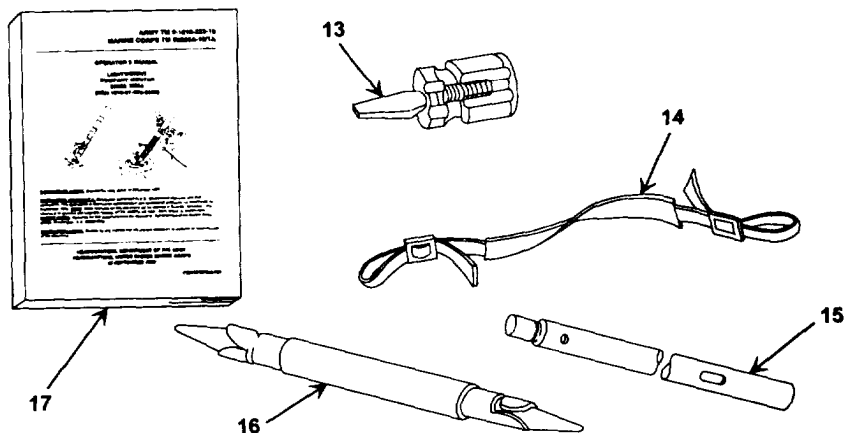

(1) ILLUS NUMBER	(2) NATIONAL STOCK NUMBER	(3) DESCRIPTION, CAGEC, AND PART NUMBER	(4) USABLE ON CODE	(5) U/M	(6) QTY RQR
13	5120-00-278-1269	SCREWDRIVER, FLAT-TIP 7/32 w tip, 1 in. lg (81348) GGG-S-121		EA	1
14	1005-00-312-7177	SLING, SMALL ARMS (19204) 12002983		EA	1
15	1010-00-225-4906	STAFF, SECTION CLEANING (19206) 8769496		EA	1
16	1010-01-043-8195	STAKE, DRIVING, AIMING POST (19200) 11741788		EA	1
17		TM 9-1010-223-10		EA	1

INTRODUCTION**Scope**

This work package lists additional items you are authorized for the support of the M224 mortar.

General

Army: Additional Authorization List. This list identifies items that do not have to accompany the M224 mortar and that do not have to be turned in with it. These items are all authorized to you by CTA, MTOE, TDA, or JTA.

Marine Corps: Using Unit Responsibility. This list identifies, in alphabetical sequence, items that will not be issued with the end item. They must be requisitioned, as required, through the supply system by the holding organization or the using unit.

Explanation of Columns In the AAL

Column (1) - National Stock Number (NSN). Identifies the stock number of the item to be used for requisitioning purposes.

Column (2) - Description, CAGEC, and Part Number. Identifies the Federal item name (in all capital letters) followed by a minimum description when needed. The last line below the description is the CAGEC (Commercial and Government Entity Code) (in parentheses) and the part number.

Column (3) - Usable On Code. When applicable, gives you a code if the item you need is not the same for different models of equipment.

Column (4) - Unit of Measure (U/M). Indicates the physical measurement or count of the item as issued per the National Stock Number shown in column (1).

Column (5) - Qty Recm. Indicates the quantity recommended.

ADDITIONAL AUTHORIZATION LIST (AAL) - Continued

0022 00

ADDITIONAL AUTHORIZATION LIST AND MARINE CORPS USING UNIT
RESPONSIBILITY LIST

(1) NATIONAL STOCKNUMBER	(2) DESCRIPTION, CAGEC, AND PART NUMBER	(3) USABLE ON CODE	(4) U/M	(5) QTY RECM
8105-00-285-4744	BAG, SAND (81349) MIL-B-12233		HD	1
2540-00-670-2459	BAG ASSEMBLY, PAMPHLET Cotton web, od (19207) 7961712 (USMC ONLY)		EA	1
7510-00-889-3494	BINDER, LOOSE-LEAF (19207) 11677003		EA	1
1240-01-058-7460	BORESIGHT, M115, OPTICAL (19200) 11748094		EA	AR
	OR			
1240-00-152-3512	BORESIGHT (W/E), M45A1, OPTICAL (19200) 10549221		EA	AR
1010-01-302-6789	BRUSH AND COVER, 60MM (59678) 11838767		EA	1
1240-00-152-2916	CASE, BORESIGHT (19200) 10599222		EA	1
1290-00-930-4260	COMPASS, MAGNETIC, UNMOUNTED M2 (19200) 10547166		EA	1
5340-01-282-1159	CRANE, HANDLE (59678) 060-195		EA	1
4930-00-537-8977	OILER, HAND (96906) MS15766-1		EA	1

ADDITIONAL AUTHORIZATION LIST (AAL) - Continued

0022 00

ADDITIONAL AUTHORIZATION LIST AND MARINE CORPS USING UNIT
RESPONSIBILITY LIST - Continued

(1) NATIONAL STOCK NUMBER	(2) DESCRIPTION, CAGEC, AND PART NUMBER	(3) USABLE ON CODE	(4) U / M	(5) QTY RECM
1220-01-059-7989	PLOTTING BOARD, M19 W/Case, Carrying (19200) 11748086		EA	1
1220-01-045-4965	SCALE, GRAPHICAL FIRING TABLE (19200) 11741798		EA	1

INTRODUCTION

Scope

This work package lists expendable and durable items that you will need to operate and maintain the M224 mortar. This list is for information only and is not authority to requisition the listed items. These items are authorized to you by CTA 50-970, Expendable/Durable Items (Except Medical, Class V Repair Parts, and Heraldic Items), or CTA 8-100, Army Medical Department Expendable/Durable Items.

Explanation of Columns in the Expendable/Durable Items List

Column (1) - Item Number. This number is assigned to the entry in the list and is referenced in the narrative instructions to identify the item (e.g., "Use cleaning compound (item 8, WP 0023 00).").

Column (2) - Level. This column identifies the lowest level of maintenance that requires the listed item (C = Operator/Crew).

Column (3) - National Stock Number (NSN). This is the NSN assigned to the item which you can use to requisition it.

Column (4) - Item Name, Description, Commercial and Government Entity Code (CAGEC), and Part Number (P/N). This column provides the other information you need to identify the item.

Column (5) - Unit of Measure (U/M). This code shows the physical measurement or count of an item, such as gallon, dozen, gross, etc.

EXPENDABLE AND DURABLE ITEMS LIST

(1) ITEM NUMBER	(2) LEVEL	(3) NATIONAL STOCK NUMBER	(4) ITEM NAME, DESCRIPTION, CAGEC, AND PART NUMBER	(5) U/M
1	C	6810-00-201-0906	ALCOHOL, DENATURED: (81348) O-E-760	PT
2	C	8105-00-269-4662	BAG, PLASTIC: (81349) MIL-B-117	EA

EXPENDABLE AND DURABLE ITEMS LIST - Continued

0023 00

EXPENDABLE AND DURABLE ITEMS LIST - Continued

(1) ITEM NUMBER	(2) LEVEL	(3) NATIONAL STOCK NUMBER	(4) ITEM NAME, DESCRIPTION, CAGEC, AND PART NUMBER	(5) U/M
3	C	8020-09-201-1870	BRUSH, ARTIST: (81348) H-B-241	EA
4	C	7920-00-205-2401	BRUSH, CLEANING TOOL: (81349) MIL-S-43871	EA
5	C	8020-00-242-7266	BRUSH, PAINT: (96906) MS16666	EA
6	c	6850-00-392-9751	CLEANING COMPOUND, OPTICAL LENS: (81349) MILC43454	OZ
7	C	6850-00-224-6663	CLEANING COMPOUND, RIFLE BORE (RBC): (81349) MILC372	CN
8	C	6850-00-597-9765	CLEANING COMPOUND, SOLVENT: (81348) O-C-1889	CN
9	C	5350-00-221-0872	CLOTH, ABRASIVE: crocus (58536) A-A-1206	PG
10	C	9150-01-197-7689	GREASE, AUTOMOTIVE (81349) MIL-G 10924 6.5 lb can	LB
11	C	9905-00-257-2746	INSTRUCTION DECAL (19200) 11731011	EA
12	C	9150-00-231-2361	LUBRICATING OIL, GENERAL PURPOSE: (GPL) (81349) MIL-L-3150	CN

EXPENDABLE AND DURABLE ITEMS LIST - Continued

0023 00

EXPENDABLE AND DURABLE ITEMS LIST - Continued

(1) ITEM NUMBER	(2) LEVEL	(3) NATIONAL STOCK NUMBER	(4) ITEM NAME, DESCRIPTION, CAGEC, AND PART NUMBER	(5) U/M
13	C	9150-00-292-9689	LUBRICATING OIL, WEAPON: (LAW) (81349) MIL-L-14107	CN
14	C	6640-00-285-4694	PAPER, LENS: (81348) NNN-P-40	EA
15	C	8010-01-229-7546	POLYURETHANE COATING (81349) MIL-C-53039	QT
16	C	7920-00-205-1711	RAG, WIPING: (58536) A-A-531	LB
17	C	7510-00-266-6712	TAPE, PRESSURE SENSITIVE ADHESIVE: 1 in. wide, 60 yd roll (19203) 8783476	YD
18	C	8010-00-160-5791	THINNER, SYNTHETIC: (81348) TT-T-306	CN

AMMUNITION MARKING INFORMATION

0024 00

AUTHORIZED CARTRIDGES

The following cartridges are authorized to be fired in the 60mm, M224 mortar:

Cartridge, 60mm: HE, M720
 Cartridge, 60mm: Illum, M721
 Cartridge, 60mm: Smoke, WP, M722
 Cartridge, 60mm: HE, M888
 Cartridge, 60mm: HE, M49A4
 Cartridge, 60mm: Smoke, WP, M302A1/M302A2
 Cartridge, 60mm: Illum, M83 Series
 Cartridge, 60mm: TP, M50A3
 Cartridge, 60mm: Training, M69
 Cartridge, 60mm: Training Device
 Cartridge, 60mm: SRTP, M766

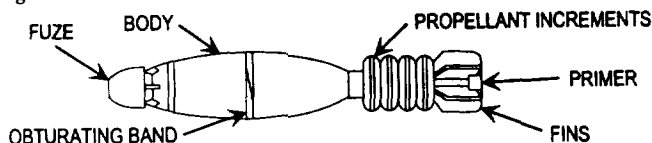
M720 Cartridge

Type/Use: High explosive/fragmentation and blast
Identification: Olive drab w/yellow markings
Components: Fuze - Multi-option, M734
 Propelling charge - M204
Max Range: 3490 Meters
Limitations: Cartridge cannot be fired above charge 1 in hand-held mode.
 Cartridge must be fired a minimum distance of 300 meters during training.
Remarks: When firing in 60mm Mortar M19 or M2, use no more than two (2) charges.

AUTHORIZED CARTRIDGES - Continued

M721 Cartridge

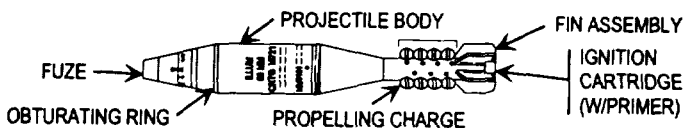

- Type/Use:** Illumination
- Identification:** White w/black markings
- Components:** Fuze - Mechanical Time Superquick (MTSQ), M776
Propelling charge - M204
- Max Range (burst):** 3490 Meters
- Limitations:** Cartridge cannot be fired below charge 1.
- Remarks:** Cartridge provides 325,000 candle power average illumination for about 40 seconds.
When firing in 60mm Mortar M19 or M2, use no more than two (2) charges.

M722 Cartridge

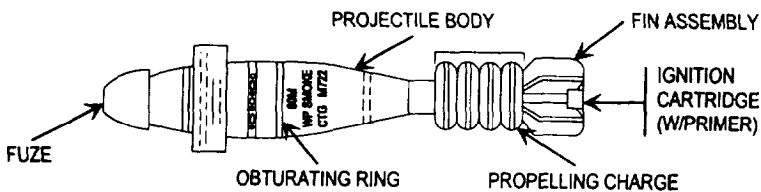

- Type/Use:** Smoke (WP)
- Identification:** Light green w/red markings and one yellow band
- Components:** Fuze - Point Detonating (PD), M745
Propelling charge - M204
- Max Range (burst):** 3490 Meters
- Remarks:** When firing in 60mm Mortar M19 or M2, use no more than two (2) charges.

AUTHORIZED CARTRIDGES - Continued

M888 Cartridge

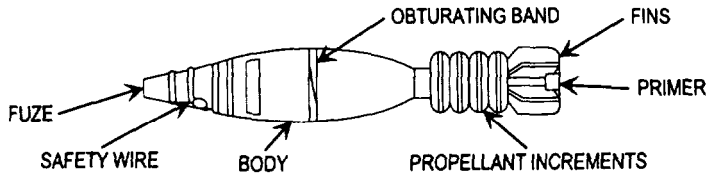

- Type/Use:** High explosive/fragmentation and blast
Identification: Olive drab w/yellow markings
Components: Fuze - PD, M935
 Propelling charge - M204
Max Range: 3490 Meters
Limitations: Cartridge cannot be fired above charge 1 in hand-held mode.
 Cartridge must. be fired a minimum distance of 300 meters during training.
Remarks: When firing in 60mm Mortar M19 or M2, use no more than two (2) charges.

M49A4 Cartridge

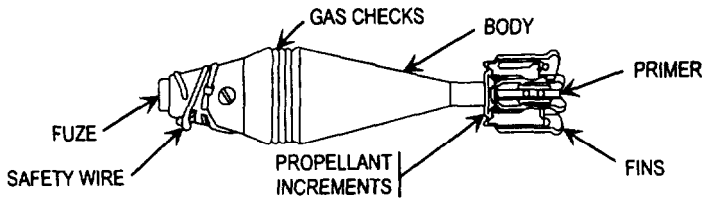

- Type/Use:** High explosive/fragmentation and blast
Identification: Olive drab w/yellow markings
Components: Fuze - PD, M525 Series or PD, M935
 Propelling charge - M181
Max Range: 1930 Meters
Limitations: Short rounds may occur when fired in below 0°F temperatures.

AUTHORIZED CARTRIDGES - Continued

M302A/M302A2 Cartridge

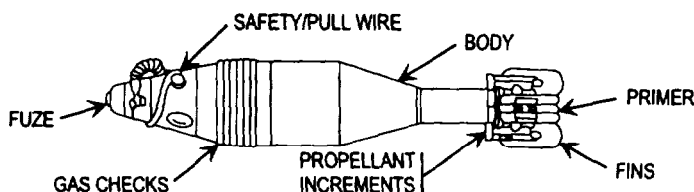

- Type/Use:** Smoke (white phosphorus)/screening and spotting
Identification: Gray w/yellow band and yellow markings or light green w/yellow band and light red markings.
Components: Fuze - PD, M527 Series or PD, M935 (M302A) Cartridge only/PD, M936 (M302A2 Cartridge only)
 Propelling charge - M181
Max Range: 1630 Meters
Limitations: Short rounds may occur when fired in below 0°F temperatures.

M83 Series Cartridge

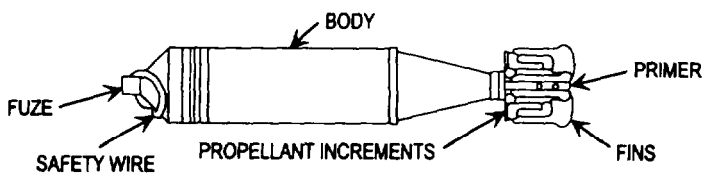

- Type/Use:** Illumination
Identification: White w/black markings
Components: Fuze - Time, M65 Series
 Propelling charge - M182
Max Range (burst): 931 Meters
Limitations: Cartridge cannot be fired below charge 2.
Remarks: Cartridge contains an illuminating candle/parachute assembly. Candles provide about 250,000 candlepower illumination for at least 30 seconds.

AUTHORIZED CARTRIDGES - Continued

M50A3 Cartridge

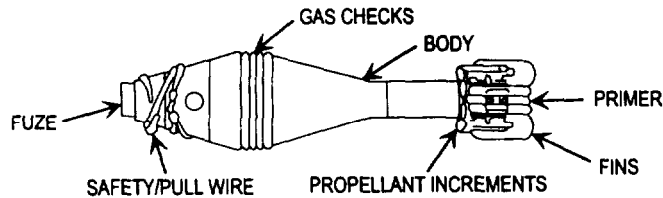

- Type/Use:** Training and practice (TP)
Identification: Blue w/white markings and brown bands
Components: Fuze - PD, M525 Series
 Propelling charge - M181
Max Range: 1930 Meters
Limitations: Short rounds may occur when fired in below 0°F temperatures.
Remarks: Cartridge contains a spotting charge.

M69 Cartridge

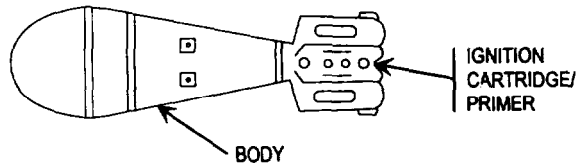

- Type/Use:** Training
Identification: Black, blue, or bronze w/white markings
Components: Fuze - None
 Propelling charge - Ignition cartridge only
Remarks: Cartridge has an inert body and can be re-used (replacement of the ignition cartridge is required for re-use).

AUTHORIZED CARTRIDGES - Continued

60MM Training Device

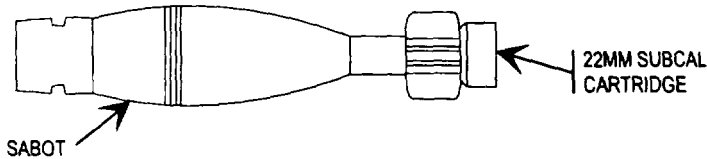

Type/Use: Training
Components: Sabot, M3
 22 mm subcaliber cartridge (M744, M745, M746, or M747)

CAUTION

Use deflector nut, NSN 1315-01-163-5428, to avoid cannon bore erosion.
 Refer to TM 9-1310-249-12&P for instructions.

M766 Cartridge

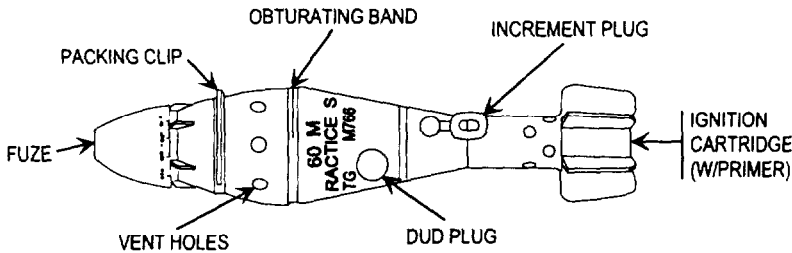

Type/Use: Target practice (short range&raining
Identification: Blue w/brown band and white markings
Components: Fuze, PD, Practice, M779
 Propelling Charge - ignition cartridge only

Max Range: 538 Meters

Remarks:

1. Projectile body is hollow.
2. Range of cartridge is reduced by removing increment plugs from projectile body. Removal of plugs allows gases to escape (from the mortar barrel) through the body and out the vent holes.
3. A pyrotechnic charge in the fuze produces a flash, an audible sound, and a cloud of smoke on impact.
4. The spent (fired) cartridges can be recovered for rebuilding and reuse. Refer to TM 9-1310-252-12&P for instructions and limitations.

PREPARATION FOR FIRING

1. Unpack cartridge.

NOTE

Remove packing stop from fuze of M720 cartridge.

Remove propelling charge support clip from M720, M721, M722, and M888 cartridges.

Examine fin assembly for visible damage or looseness. Retighten loose fin assemblies (by hand) before firing. Cartridges with damaged (bent) fins shall be turned in to the Ammunition Supply Point (ASP) as unserviceable.

2. Set fuze for desired type of burst (M720 and M888 cartridges).

NOTE

Position propelling charge increments as close to the fin as possible to avoid short rounds.

3. Adjust propelling charge for desired range.
4. Remove fuze pull/safety wires (just prior to loading and firing cartridge).

WARNING

M525 and M527 PD Fuzes. Do not fire cartridge if fuze makes a buzzing sound when removing safety pins. Check fuze for presence of bore-riding pin after removing safety pin. Do not fire cartridge if bore-riding pin is missing. Notify Explosive Ordnance Disposal (EOD).

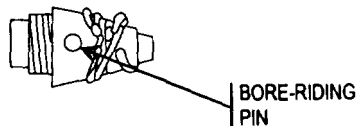

LOADING AND FIRING

WARNING

Firing overhead of unprotected troops is prohibited per AR 385-63.

Adequate fragmentation cover will be taken when firing cartridges for distances less than 300 meters. During training, cartridge will be fired a minimum distance of 300 meters.

Firing temperature limits for M720, M721, M722, and M888 cartridges are -50°F to +145°F. Temperature limits for all other cartridges are -40°F to + 125°F.

CAUTION

Before loading cartridge into cannon, ensure that all components are free of sand, mud, moisture, frost, snow, ice, or other foreign matter.

1. Check to ensure that cartridge has proper amount of charge.
2. Ensure that safety wire/clip (if any) is removed before firing.
3. Refer to chapter 2 for loading and firing instructions.

UNFIRED CARTRIDGES

CAUTION

Replace upper safety pin first on PD M525 and M527 fuzes.

If safety pins cannot be fully inserted into fuze, notify EOD.

1. Replace safety wire if removed from fuze.
2. Reset fuze.
3. Re-install propellant increments so that cartridge has a full charge.

NOTE

Do not mix propellant lots.

4. Install packing stop (M720 cartridge). Repack cartridge in original packaging.

CARE AND HANDLING OF CARTRIDGES**WARNING**

Do not fire unpacked ammunition which has been dropped, or packaged ammunition which has been dropped from a height greater than one meter. These cartridges will be returned to Ammunition Supply Point (ASP) as unserviceable.

1. Do not throw or drop live ammunition.
2. Use proper tools to open ammo boxes and ammo containers.
3. Do not break moisture resistant seal of ammo containers until cartridges are to be fired.
4. Protect cartridges when removed from ammo container. Protect ammunition from rain and snow. Cover fin assembly and propelling charge with fiber container lid/end cap. Stack cartridges on top of empty ammo boxes. Cover cartridges with plastic sheets.
5. Protect ammunition from direct rays of the sun.
6. Store WP-loaded cartridges at temperatures below 111°F to prevent melting of the WP filler. If this is not possible, WP-loaded cartridges must be stored fuze-end up so that the WP will resolidify with the void space in the nose end of the cartridge (when the temperature returns below 111°F). Failure to observe this precaution could result in rounds with erratic flight.
7. Store WP-loaded munitions separate from other types of ammunition.
8. Notify EOD of leaking WP cartridges. Avoid contact with any leakers.
9. Do not handle duds.

FUZES

Mechanical Time Superquick, M776 Fuze

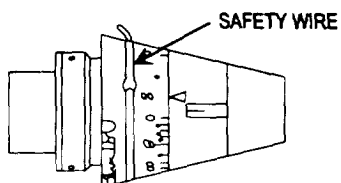

Functions: Airburst/Impact

settings: 6 to 52 seconds

Remarks: Fuze has a mechanical arming/timing device, expulsion charge, and safety wire/pin.

Point Detonating, M745 Fuze

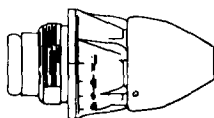

Functions: Impact

settings: None

Remarks: Fuze functions on impact w/superquick action only. The markings (PRX, NSB, IMP, and DLY) are dummy settings. Rotation of the fuze head does not alter the function mode.

Multi-option, M734 Fuze

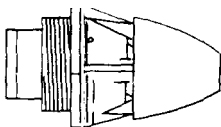

Functions: Prox/impact

settings: Prox, near surface burst, impact, or 0.05 second delay action.

Remarks: Fuze is handsettable.

FUZES - Continued

Point Detonating, M935 and M936 Fuzes

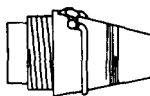

Functions: Impact
 settings: Superquick or 0.05 second delay action (M936 fuze used on SQ setting only).
 Remarks: Fuze has a safety wire.

Point Detonating, M525 and M527 Fuzes



Functions: Impact
 settings: None (superquick only)
 Remarks: Fuzes have bore-riding pins and safety wires.

Time, M65 Series Fuze

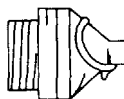

Functions: Air burst
 settings: None (Fixed time)
 Remarks: Fuze has a time train expelling charge and safety wire.

AMMUNITION MARKING INFORMATION - Continued

0024 00

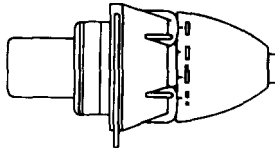
FUZES - Continued**Point Detonating, Practice, M779**

Function: Impact
settings: Dummy Multi-option
PRX/NSB/IMP/DLY
Remarks: Fuze has a smoke charge and a safety/packing clip.

FUZE SETTING

M779 Point Detonating (Practice) Fuze

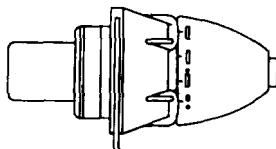

1. This fuze only functions superquick on impact.
2. Remove safety/packing clip from fuze just prior to firing.
3. This fuze has dummy multi-option PRX/NSB/IMP/DLY settings (for practice only).

FUZE SETTING - Continued

M734 Multi-option Fuze

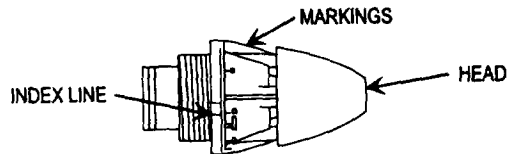

1. Fuzes can be set by hand.
2. Set fuze by rotating fuze head (in clockwise direction) until correct marking (PRX, NSB, IMP, or DLY) is over index line.
3. Next illustration depicts burst types.

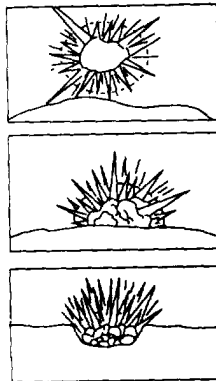

PRX- Proximity. The fuze comes set to PRX. (Burst height is 3-13 ft)

NSB - Near Surface (nonjamming)
(Burst height is 0-3 ft)

IMP -Impact (SQ)

DLY - Delay (0.050 seconds)

FUZE SETTING - Continued

M776 MTSQ Fuze

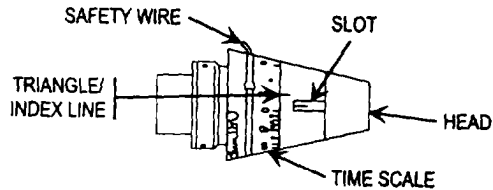

1. Rotate head of the fuze to the left (counterclockwise direction) until the inverted triangle/index line is lined up with the correct line and number of seconds of the time scale.
2. Use fuze setter (p 0024 00-16) to rotate the head of the fuze.
3. See firing table for correct time setting.
4. Remove safety wire just prior to firing.

M745 PD Fuze

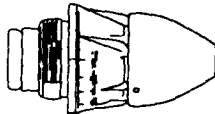

1. No setting required.
2. Fuze functions on impact with superquick action only. Disregard the markings (PRX, NSB, IMP, and DLY) on the fuze head.

FUZE SETTING - Continued

M935 and M936 PD Fuzes



SUPERQUICK SETTING

1. Superquick setting

- a. These fuzes are shipped pre-set to function superquick on impact.
- b. Verify setting prior to firing, Selector slot should be aligned with SQ-mark on ogive.



DELAY SETTING

2. Delay setting (for M935 fuzes only)

- a. Turn selector slot in clockwise direction until slot is aligned with D-marking on ogive.
- b. Use a flat tip screwdriver to change settings.

FUZE WRENCH/SETTERS

Fuze Setter (Part No. 12929246)

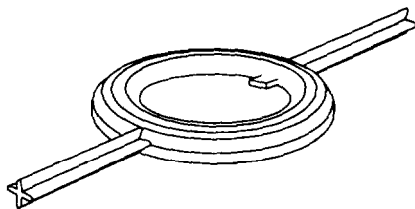

1. Sets M776 MTSQ and DM93 Fuzes.
2. Engages the single slotted fuze head.

RESETTING FUZES

- | | |
|------------------------|---|
| M776 MTSQ Fuze - | Rotate fuze head counterclockwise until inverted triangle/index line is lined up with "S" line. |
| M745 PD Fuze - | No resetting required. |
| M734 Multi-option Fuze | Rotate fuze head (in counterclockwise direction) until PRX-marking is over index line. |
| M935 PD Fuze - | Align selector slot with SQ-marking. |

PROPELLING CHARGES

MODEL NO.	NO. OF INCREMENTS	TYPE OF CONTAINER	TYPE OF PROPELLANT
M181	4	Cellophane bags	M8 sheets
M182	4	Cellophane bags	M&3 sheets
M204	4	Nitrocellulose/ fiber containers (horseshoe shaped)	M10 flake

ADJUSTMENT OF PROPELLING CHARGE

WARNING

Propelling charges are not interchangeable. Do not substitute one model for another. Do not mix lots.

1. Cartridges are shipped with a complete propelling charge, ignition cartridge, and primer.
2. Use firing table to determine proper charge for firing.
3. With the exception of M766 TP cartridge and M69 training cartridge, reduce charge by removing proper number of propellant increments. Following chart shows number of increments that should be remaining.

- Charge 0- Ignition cartridge only
- Charge 1- Ignition cartridge and one increment
- Charge 2- Ignition cartridge and two increments
- Charge 3- Ignition cartridge and three increments
- Charge 4- Ignition cartridge and four increments

ADJUSTMENT OF PROPELLING CHARGE - Continued

WARNING

Failure to reposition M204 propelling charge increments could result in a short round.

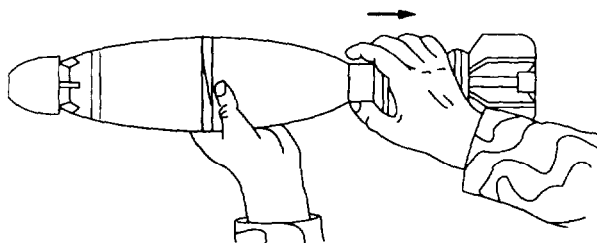

4. Slide remaining increments towards rear, until positioned against fins (M720, M721, M722, and M888 cartridges only).
5. Reduce range of M766 TP cartridge by removing plastic plugs from projectile body. The following chart shows number of plugs that should be remaining.

Charge 0 - Ignition cartridge only

Charge 1 - Ignition cartridge and one plug

Charge 2 - Ignition cartridge and two plugs

Charge 3 - Ignition cartridge and three plugs

6. Place excess increments in an empty ammo box for protection. Close lid of box during firing to prevent accidental ignition from burning debris/residue.

MARINE CORPS INVENTORY SHEET

0025 00

NOTE

Commanders will maintain sufficient quantity to support mission requirements.

		INVENTORY SHEET																						
		NAME OF EQUIPMENT		M224 60MM LIGHTWEIGHT COMPANY MORTAR																				
ITEM NO.	STOCK NUMBER	ITEM IDENTIFICATION	UNIT OF MEAS	QTY USED IN UNIT	MONTH												REMARKS							
1	6810-00-201-0906	ALCOHOL, DENATURED		AR																				
2	8105-00-269-4662	BAG, PLASTIC	EA	AR																				
3	8105-00-285-4744	BAG, SAND	HD	1																				
4	2540-00-670-2459	BAG ASSEMBLY, PAMPHLET	EA	1																				
5	1010-01-043-7504	BASEPLATE, MORTAR, M7	EA	1																				
6	1010-01-043-4661	BASEPLATE, MORTAR, M8	EA	1																				
7	7510-00-889-3494	BINDER, LOOSE-LEAF	EA	1																				
8		BIPOD, 60MM MORTAR M170	EA	1																				
9	0000-00-005-9811	BOOK, WEAPONS RECORD	EA	1																				
10	1240-00-152-3512	BORESIGHT (W/E), M45A1, OPTICAL	EA	AR																				
11	1240-01-058-7460	BORESIGHT, M115, OPTICAL	EA	AR																				
12	8020-00-201-1870	BRUSH, ARTIST	EA	1																				
13	1010-01-044-186:	BRUSH, CLEANING, ARTILLERY	EA	1																				
14	7920-00-205-2401	BRUSH, CLEANING TOOL	EA	AR																				
15	8020-00-242-7266	BRUSH, PAINT	EA	AR																				
16	1010-01-301-6789	BRUSH AND COVER, 60MM	EA	1																				
17		CANNON, 60MM MORTAR, M225	EA	1																				

MARINE CORPS INVENTORY SHEET - Continued

0025 00

INVENTORY SHEETS																				
NAME OF EQUIPMENT M224 60MM LIGHTWEIGHT COMPANY MORTAR																				
ITEM NO.	NUMBER	ITEM IDENTIFICATION	UNIT OF MEAS	QTY USED IN UNIT	MONTH												REMARKS			
18	1290-01-043-6266	CASE, AIMING POST	EA	1																
19	1240-00-152-2916	CASE, BORESIGHT	EA	1																
20	1240-01-044-4572	CASE, SIGHT UNIT	EA	1																
21	5650-00-224-6663	CLEANING COMPOUND, RIFLE BORE	CN	AR																
22	6850-00-392-392-9751	CLEANING COMPOUND, OPTICAL LENS	OZ	AR																
23	6850-00-597-97-65	CLEANING COMPOUND, SOLVENT	CN	AR																
24	5350-00-221-0872	CLOTH, ABRASIVE	PG	AR																
25	1290-00-930-4260	COMPASS, MAGNETIC, UNMOUNTED M2	EA	1																
26	1240-01-043-7502	COVER, FIRE CONTROL	EA	1																
27	1010-01-048-1420	COVER, GUN MUZZLE	EA	1																
28	5340-01-282-1169	CRANE, HANDLE	EA	1																
29	1390-01-326-0676	FUZE SETTER, MTSQ	EA	1																
30	9150-01-197-7689	GREASE, AUTOMOTIVE	LB	AR																
31	5340-00-257-1033	HOOK, ARTILLERY, CLEANING	EA	1																
32	9905-00-257-2746	INSTRUCTION DECAL	EA	AR																
33	1290-00-169-1934	LIGHT, AIMING POST, M58	EA	2																
34	1290-00-169-1935	LIGHT, AIMING POST, M59	EA	1																
35	9150-00-231-2361	LUBRICATING OIL, GENERAL PURPOSE	CN	AR																
36	9150-292-9689	LUBRICATING OIL, WEAPON	CN	AR																

MARINE CORPS INVENTORY SHEET - Continued

0025 00

INVENTORY SHEET																				
NAME OF EQUIPMENT <u>M224 60MM LIGHTWEIGHT COMPANY MORTAR</u>																				
ITEM NO.	STOCK NUMBER	ITEM IDENTIFICATION	UNIT OF MEAS	QTY USED IN UNIT	MONTH												REMARKS			
37	8415-01-092-0039	MITTEN. HEAT PROTECTIVE	EA	1																
38	1240-01-201-8299	MOUNT, TELESCOPE	EA	1																
39	4930-00-537-8977	OILER, HAND	EA																	
40	6640-00-285-4694	PAPER, LENS	EA																	
41	1220-01-059-7989	PLOTTING BOAR, M19	EA																	
42	8010-01-229-7546	POLYURETHANE COATING	QT																	
43	1290-01-046-8320	POST, AIMING, M14	EA																	
44	7920-00-205-1711	RAG, WIPING	LB																	
45	1220-01-045-4965	SCALE, GRAPHICAL FIRING TABLE	EA																	
46	5120-00-820-2995	SCREWDRIVER CROSS TIP	EA																	
47	5120-00-278-1269	SCREWDRIVER, FLAT TIP	EA																	
48	1240-01-379-7953	SIGHT, M64A1	EA																	
49	1005-00-312-7177	SLING, SMALL ARMS	EA																	
50	1010-00-225-4906	STAFF, SECTION CLEANING	EA																	
51	1010-01-043-8195	STAKE, DRIVING, AIMING POST	EA																	
52	7510-00-266-6712	TAPE, PRESSURE SENSITIVE ADHESIVE	TD																	
53	6650-01-211-3608	TELESCOPE, ELBOW, OPTICAL DEVICE	EA																	
54	8010-00-160-5791	THINNER, SYNTHETIC	CN																	
55		TM 9-1010-223-10	EA																	

INDEX

<u>Subject</u>	<u>WP Sequence No. - Page NO.</u>
A	
Additional Authorization List (AAL)	0022 00-1
Adjustment of Propelling Charge.....	0024 00-17
Ammunition Marking Information	0024 00-1
Assembly and Preparation for Firing - Conventional Mode . .	0005 00-1
Assembly and Preparation for Firing - Hand-held Mode.....	0006 00-1
Authorized Cartridges	0024 00-1
B	
Boresighting	0005 00-9
C	
Care and Cleaning of Optical Parts	0019 00-1
Care and Handling of Cartridges.....	0024 00-9
Components of End Item (COED and Basic Issue Items (BII) Lists	0021 00-1
Cookoff	0010 00-1
Corrosion Prevention and Control (CPC)	0001 00-2
D	
Description and Use of Operator Controls and Indicators	0004 00-1
Destruction of Materiel to Prevent Enemy Use	0001 00-3
Differences Between Modes	0002 00-3
Drop Fire Method.....	0003 00-1
E	
Emplacement of Mortar (Conventional Mode).....	0005 00-1
Emplacing Aiming Posts for Indirect Fire.....	0007 00-1
Equipment Characteristics, Capabilities, and Features	0002 00-1
Equipment Data.....	0002 00-4
Equipment Description and Data	0092 00-1
Expendable and Durable Items List.....	0023 00-1
F	
Fuze Setting	0024 00-12
Fuze Wrench/Setters	0024 00-1
Fuzes	0024 00-10

TM 9-1010-223-10

INDEX - CONTINUED

<u>Subject</u>	<u>WP Sequence No. - Page No.</u>
G	
General Information	0001 00-1
H	
Hangfire	0010 00-1
I	
Installation of M64/M64A1 Sight Unit	0005 00-5
L	
Loading and Firing - Ammunition.	0024 00-8
Loading and Firing - Conventional Mode.	0008 00-1
Loading and Firing - Hand-held Mode	0009 00-1
Location and Description of Major Components.	0002 00-1
Lubrication Instructions.	0017 00-2
M	
Maintenance Forms, Records, and Reports.	0001 00-1
Maintenance Procedures	0018 00-1
Marine Corps Inventory Sheet	0025 00-1
Misfire	0010 00-1
Misfire Procedure - Conventional Mode	0010 00-1
Misfire Procedure - Hand-held Mode.	0011 00-1
Model Number and Equipment Name.	0001 00-1
O	
Operating Procedures - Emplacing Aiming Posts for Indirect Fire	0007 00-1
Operating Procedures - Loading and Firing Conventional Mode	0008 00-1
Hand-held Mode	0009 00-1
Operation Under Unusual Conditions	0014 00-1

INDEX - CONTINUED

<u>Subject</u>	<u>WP Sequence No. - Page</u>
P	
Preparation for Firing	0024 00-7
Preparation for Movement - Conventional Mode	0012 00-1
One Man Carry.....	0012 00-1
Three Man Carry	0012 00-7
Two Man Carry	0012 00-5
Preparation for Movement - Hand-held Mode	0013 00-1
Preventive Maintenance Checks and Services (PMCS), Including Lubrication Instructions..	0017 00-1
Introduction.....	0017 00-1
Lubrication Chart	0017 00-2
Lubrication Instructions	0017 00-2
PMCS Procedures	0017 00-3
Propelling Charges	0024 00-17
Purpose of Equipment	0001 00-1
R	
References	0020 00-1
Reporting Equipment Improvement Recommendations (EIR)	0001 00-2
Resetting Fuses	0024 0016
S	
Scope.....	0001 00-1
60MM, M224 Lightweight Company Mortar Maintenance	0018 00-1
T	
Theory of Operation.....	0003 00-1
Trigger Fire Method	0003 00-3
Troubleshooting - Introduction	0015 00-1
Troubleshooting Procedures.....	0016 00-1
U	
Untired Cartridges..	0024 00-8

By Order of the Secretary of the Army:

DENNIS J. REIMER
General, United States Army
Chief of Staff

Official:

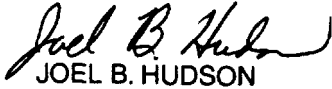

Handwritten signature of Joel B. Hudson in black ink.

JOEL B. HUDSON
Administrative Assistant to the
Secretary of the Army
05348

DISTRIBUTION: To be distributed in accordance with the Initial Distribution Number (IDN) 400550, requirements for TM 9-1010-223-10.

RECOMMENDED CHANGES TO EQUIPMENT TECHNICAL PUBLICATIONS



SOMETHING WRONG

WITH THIS PUBLICATION?

THEN... JOT DOWN THE DOPE ABOUT IT ON THIS FORM. CAREFULLY TEAR IT OUT, FOLD IT AND DROP IT IN THE MAIL!

FROM: (PRINT YOUR UNIT'S COMPLETE ADDRESS)

Your address

DATE SENT

PUBLICATION NUMBER

TM 9-1010-223-10

PUBLICATION DATE

15 Sep 98

PUBLICATION TITLE

Operator's Manual
Lightweight Company Mortar

BE EXACT. PIN-POINT WHERE IT IS				IN THIS SPACE TELL WHAT IS WRONG AND WHAT SHOULD BE DONE ABOUT IT:
PAGE NO	PARA-GRAPH	FIGURE NO	TABLE NO	
i	Title			NSN should read: (NSN 1010-01-020-5625.

SAMPLE

PRINTED NAME, GRADE OR TITLE AND TELEPHONE NUMBER

Your name and title.

SIGN HERE

DA FORM 2028-2
1 JUL 79

PREVIOUS EDITIONS ARE OBSOLETE.

P.S. - IF YOUR OUTFIT WANTS TO KNOW ABOUT YOUR RECOMMENDATION MAKE A CARBON COPY OF THIS AND GIVE IT TO YOUR HEADQUARTERS

RECOMMENDED CHANGES TO EQUIPMENT TECHNICAL PUBLICATIONS

 <p style="font-size: small;">THEN... JOT DOWN THE DOPE ABOUT IT ON THIS FORM. CAREFULLY TEAR IT OUT. FOLD IT AND DROP IT IN THE MAIL!</p>		SOMETHING WRONG WITH THIS PUBLICATION?	
		FROM: (PRINT YOUR UNIT'S COMPLETE ADDRESS)	
PUBLICATION NUMBER		PUBLICATION DATE	
TM 9-1010-223-10		15 Sep 98	
PUBLICATION TITLE		Operator's Manual Lightweight Company Mortar	
BE EXACT PIN-POINT WHERE IT IS			
PAGE NO	PARA-GRAPH	FIGURE NO	TABLE NO
IN THIS SPACE TELL WHAT IS WRONG AND WHAT SHOULD BE DONE ABOUT IT:			
PRINTED NAME GRADE OR TITLE AND TELEPHONE NUMBER			SIGN HERE

DA FORM 2028-2
1 JUL 79

PREVIOUS EDITIONS ARE OBSOLETE.

PS--IF YOUR OUTFIT WANTS TO KNOW ABOUT YOUR RECOMMENDATION MAKE A CARBON COPY OF THIS AND GIVE IT TO YOUR HEADQUARTERS

FILL IN YOUR UNIT'S ADDRESS



DEPARTMENT OF THE ARMY



OFFICIAL BUSINESS

NO POSTAGE
NECESSARY
IF MAILED
IN THE
UNITED STATES

BUSINESS REPLY MAIL

FIRST CLASS

PERMIT NO 82

ROCK ISLAND IL

POSTAGE WILL BE PAID BY ROCK ISLAND ARSENAL



**DIRECTOR
ARMAMENT AND CHEMICAL ACQUISITION
AND LOGISTICS ACTIVITY
ATTN: AMSTA-AC-NMLI
ROCK ISLAND IL 61201-9948**

TEAR ALONG PERFORATED LINE



RECOMMENDED CHANGES TO EQUIPMENT TECHNICAL PUBLICATIONS



SOMETHING WRONG

WITH THIS PUBLICATION?

FROM: (PRINT YOUR UNIT'S COMPLETE ADDRESS)

DATE SENT

THEN... JOT DOWN THE DOPE ABOUT IT ON THIS FORM. CAREFULLY TEAR IT OUT. FOLD IT AND DROP IT IN THE MAIL!

PUBLICATION NUMBER

TM 9-1010-223-10

PUBLICATION DATE

15 Sep 98

PUBLICATION TITLE

Operator's Manual
Leightweight Company Mortar

BE EXACT . PIN-POINT WHERE IT IS				IN THIS SPACE TELL WHAT IS WRONG AND WHAT SHOULD BE DONE ABOUT IT:
PAGE NO	PARA-GRAPH	FIGURE NO	TABLE NO	

PRINTED NAME GRADE OR TITLE AND TELEPHONE NUMBER

SIGN HERE

FILL IN YOUR UNIT'S ADDRESS

DEPARTMENT OF THE ARMY

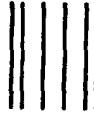

OFFICIAL BUSINESS

NO POSTAGE
NECESSARY
IF MAILED
IN THE
UNITED STATES

BUSINESS REPLY MAIL

FIRST CLASS

PERMIT NO 82

ROCK ISLAND IL

POSTAGE WILL BE PAID BY ROCK ISLAND ARSENAL

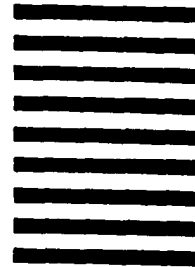

**DIRECTOR
ARMAMENT AND CHEMICAL ACQUISITION
AND LOGISTICS ACTIVITY
ATTN: AMSTA-AC-NMLI
ROCK ISLAND IL 61201-9948**

TEAR ALONG PERFORATED LINE



RECOMMENDED CHANGES TO EQUIPMENT TECHNICAL PUBLICATIONS

 <p style="font-size: 1.2em; font-weight: bold; margin: 0;">SOMETHING WRONG WITH THIS PUBLICATION?</p>		FROM: (PRINT YOUR UNIT'S COMPLETE ADDRESS)		
		DATE SENT		
PUBLICATION NUMBER TM 9-1010-223-10		PUBLICATION DATE 15 Sep 98	PUBLICATION TITLE Operator's Manual Lightweight Company Mortar	
BE EXACT - PIN-POINT WHERE IT IS				
PAGE NO	PARA-GRAPH	FIGURE NO	TABLE NO	IN THIS SPACE TELL WHAT IS WRONG AND WHAT SHOULD BE DONE ABOUT IT:
PRINTED NAME GRADE OR TITLE AND TELEPHONE NUMBER			SIGN HERE	

DA FORM 2028-2
1 JUL 79

PREVIOUS EDITIONS ARE OBSOLETE.

PS--IF YOUR OUTFIT WANTS TO KNOW ABOUT YOUR RECOMMENDATION MAKE A CARBON COPY OF THIS AND GIVE IT TO YOUR HEADQUARTERS

FILL IN YOUR
UNIT'S ADDRESS



DEPARTMENT OF THE ARMY

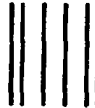

OFFICIAL BUSINESS

NO POSTAGE
NECESSARY
IF MAILED
IN THE
UNITED STATES

BUSINESS REPLY MAIL

FIRST CLASS

PERMIT NO. 82

ROCK ISLAND IL

POSTAGE WILL BE PAID BY ROCK ISLAND ARSENAL



TEAR ALONG PERFORATED LINE

**DIRECTOR
ARMAMENT AND CHEMICAL ACQUISITION
AND LOGISTICS ACTIVITY
ATTN: AMSTA-AC-NMLI
ROCK ISLAND IL 61201-9948**



PIN: 048819-000