

First edition  
2004-05-01

---

---

**Bamboo — Determination of physical and  
mechanical properties —**

**Part 2:  
Laboratory manual**

*Bambou — Détermination des propriétés physiques et mécaniques —  
Partie 2: Manuel de laboratoire*



Reference number  
ISO/TR 22157-2:2004(E)

**PDF disclaimer**

This PDF file may contain embedded typefaces. In accordance with Adobe's licensing policy, this file may be printed or viewed but shall not be edited unless the typefaces which are embedded are licensed to and installed on the computer performing the editing. In downloading this file, parties accept therein the responsibility of not infringing Adobe's licensing policy. The ISO Central Secretariat accepts no liability in this area.

Adobe is a trademark of Adobe Systems Incorporated.

Details of the software products used to create this PDF file can be found in the General Info relative to the file; the PDF-creation parameters were optimized for printing. Every care has been taken to ensure that the file is suitable for use by ISO member bodies. In the unlikely event that a problem relating to it is found, please inform the Central Secretariat at the address given below.

© ISO 2004

All rights reserved. Unless otherwise specified, no part of this publication may be reproduced or utilized in any form or by any means, electronic or mechanical, including photocopying and microfilm, without permission in writing from either ISO at the address below or ISO's member body in the country of the requester.

ISO copyright office  
Case postale 56 • CH-1211 Geneva 20  
Tel. + 41 22 749 01 11  
Fax + 41 22 749 09 47  
E-mail [copyright@iso.org](mailto:copyright@iso.org)  
Web [www.iso.org](http://www.iso.org)

Published in Switzerland

# Contents

Page

Foreword .....	iv
Introduction .....	v
<b>1</b> <b>Scope</b> .....	<b>1</b>
4.2.1 <b>Measurement and weight</b> .....	<b>1</b>
4.2.2 <b>Temperature and humidity</b> .....	<b>1</b>
<b>5.6</b> <b>Marking and conversion into test specimens</b> .....	<b>5</b>
<b>6</b> <b>Moisture content</b> .....	<b>8</b>
6.3 <b>Apparatus</b> .....	<b>8</b>
6.4 <b>Preparation of test specimen</b> .....	<b>8</b>
<b>7</b> <b>Mass by volume</b> .....	<b>8</b>
7.1 <b>Scope</b> .....	<b>8</b>
7.4 <b>Preparation of test pieces</b> .....	<b>8</b>
7.5 <b>Procedure</b> .....	<b>8</b>
7.6 <b>Determination in the absolutely dry condition</b> .....	<b>10</b>
<b>8</b> <b>Shrinkage</b> .....	<b>10</b>
8.5.2 <b>Procedure</b> .....	<b>10</b>
<b>9</b> <b>Compression</b> .....	<b>11</b>
9.3 <b>Apparatus</b> .....	<b>11</b>
9.4 <b>Preparation of test specimens</b> .....	<b>11</b>
9.6.2 <b>Range of readings</b> .....	<b>12</b>
<b>10</b> <b>Static bending</b> .....	<b>12</b>
10.1 <b>Scope</b> .....	<b>12</b>
10.3 <b>Apparatus</b> .....	<b>12</b>
10.4 <b>Preparation of test culms</b> .....	<b>12</b>
10.5.1 <b>Moment of inertia (see 10.5.4)</b> .....	<b>12</b>
10.5.2 <b>Procedure</b> .....	<b>13</b>
10.5.3 <b>E-modulus</b> .....	<b>13</b>
<b>11</b> <b>Shear</b> .....	<b>18</b>
11.1 <b>Scope</b> .....	<b>18</b>
11.4.2 <b>Specimens</b> .....	<b>18</b>
<b>12</b> <b>Tension</b> .....	<b>19</b>
12.4.2 <b>Specimens</b> .....	<b>19</b>
12.4.4 <b>Form of the specimens</b> .....	<b>19</b>
<b>Bibliography</b> .....	<b>21</b>

## Foreword

ISO (the International Organization for Standardization) is a worldwide federation of national standards bodies (ISO member bodies). The work of preparing International Standards is normally carried out through ISO technical committees. Each member body interested in a subject for which a technical committee has been established has the right to be represented on that committee. International organizations, governmental and non-governmental, in liaison with ISO, also take part in the work. ISO collaborates closely with the International Electrotechnical Commission (IEC) on all matters of electrotechnical standardization.

International Standards are drafted in accordance with the rules given in the ISO/IEC Directives, Part 2.

The main task of technical committees is to prepare International Standards. Draft International Standards adopted by the technical committees are circulated to the member bodies for voting. Publication as an International Standard requires approval by at least 75 % of the member bodies casting a vote.

In exceptional circumstances, when a technical committee has collected data of a different kind from that which is normally published as an International Standard ("state of the art", for example), it may decide by a simple majority vote of its participating members to publish a Technical Report. A Technical Report is entirely informative in nature and does not have to be reviewed until the data it provides are considered to be no longer valid or useful.

Attention is drawn to the possibility that some of the elements of this document may be the subject of patent rights. ISO shall not be held responsible for identifying any or all such patent rights.

ISO/TR 22157-2 was prepared by Technical Committee ISO/TC 165, *Timber structures*, in collaboration with INBAR, the International Network for Bamboo and Rattan.

## Introduction

In many laboratories in bamboo-growing countries all over the world, laboratory staff perform tests on the properties of bamboo. Visitors to such laboratories have seen how diligent and keen staff are on doing their work, in many cases under circumstances that are not easy. Many examples can be found of very satisfactory methods or tools, but such good information stays inside the originating laboratory, due to lack of exchange of such knowledge. One purpose of this Technical Report is to publish clever methods in order to make these available for staff all over the world. A second purpose is to give a practical “how to do” explanation on how to perform tests according to ISO 22157-1.



# Bamboo — Determination of physical and mechanical properties —

## Part 2: Laboratory manual

### 1 Scope

This Technical Report provides informative guidelines for staff in laboratories on how to perform tests according to ISO 22157-1.

NOTE From here on, this Technical Report will only give information on subclauses of ISO 22157-1 if needed; consequently the numbering is not successive.

#### 4.2.1 Measurement and weight

NOTE This subclause also refers to: 5.3 Felling, marking and conversion.

The values for length and weight should be taken:

- from the culms after their arrival in the lab, which means that culms have been marked already according to 5.3 of ISO 22157-1;
- from the smaller specimens immediately after they have been cut to size in the laboratory. It is wise to perform this cutting activity in such a way that confusion is avoided.

It is wise laboratory practice to design standard tables in which all data should be recorded. Figure 1 gives an example of such a table; evidently each laboratory is free to follow this example or not, provided their tables are as good or even better. In Figure 2 this table is repeated, and filled in by hand as an example of how to deal with it.

Next, it is wise to make a sketch of each culm, with its nodes, the places of the nodes, and the specimens cut from this culm and the tests for which these are to be used; see example in Figure 3.

This example shows the bottom and the middle part of a culm; from each part, two samples will be tested in compression and one in bending, provided the length is sufficient. The reports on those tests will contain more sketches with dimensions, etc. Evidently, each laboratory is free to design sketches like these, provided they are clear.

In Figure 3, the white ring as in 5.3 appears at a height of about 0,70 m from which we can guess that a piece of about 0,30 m has been left in the plantation. The mark "T", painted at breast height (5.2) appears at a height of approx. 1,20 m.

Subclause 4.2.1 of ISO 22157-1 also specifies how to determine the diameter and the wall thickness; see Figure 4 for details. (This Figure refers to 10.5.1 of ISO 22157-1.)

#### 4.2.2 Temperature and humidity

The choice of test condition of  $27 \pm 2$  °C and  $70 \pm 5$  % R.H deviates from that normally adopted for testing wood products which is 20 °C and 65 % R.H. The first condition is chosen to better reflect the service environment in countries where bamboo grows. In temperate climates (like W. Europe), the national standard

for timber may be followed. If the link with other conditions is known, it is recommended to add this in the test report. See also ISO 22157-1, 5.7, last line.

NOTE This subclause is based on contributions from the Canadian and the French Standards Institutes.

Name, address, etc. of the Laboratory.

1 Name of species:

1 a. Botanical name (if known)

1 b. Local name

2 Name of the locality

3. Number of clumps or groups selected and given marks							
4. Number of culms cut from each clump and given marks							
5. Age of the culms in years							
6. Details about the marks on the culms							
7. Number of nodes between ground level and the ring of paint							
8. Date of felling							
9. Date of dispatch							

10. Signature and name of responsible staff member

Figure 1 — Example of a table as in 5.3 and 4.2.1



Name, address, etc. of the Laboratory.

INBAR,  
P.O. BOX 777  
BAMBOO - TOWN.

1 Name of species:

1.a Botanical name (if known) GUADUA A.

1.b Local name —

2 Name of the locality GUAPILES

3. Number of clumps selected and given marks	3						
	A	A	B	B	B	C	C
4. Number of culms cut from each clump and given marks	2		3			2	
	A-1	A-2	B-1	B-2	B-3	C-1	C-2
5. Age of the culms in years	4	5	4	4	5	5	4
6. Details about the marks on the culms	WHITE-RING →						
7. Number of nodes between ground level and the ring of paint	3	4	3	3	4	4	3
8. Date of felling	28/1	28/1	28/1	28/1	29/1	29/1	29/1
9. Date of dispatch	30/1	30/1	30/1	31/1	31/1	31/1	31/1

10 Signature and name of responsible staff member

Julio



Figure 2 — Example of a completed table as in 5.3 and 4.3.1

- Name and address of the laboratory:
- Mark of the culm:
- Sketch of the culm, dimensions and tests to be performed:

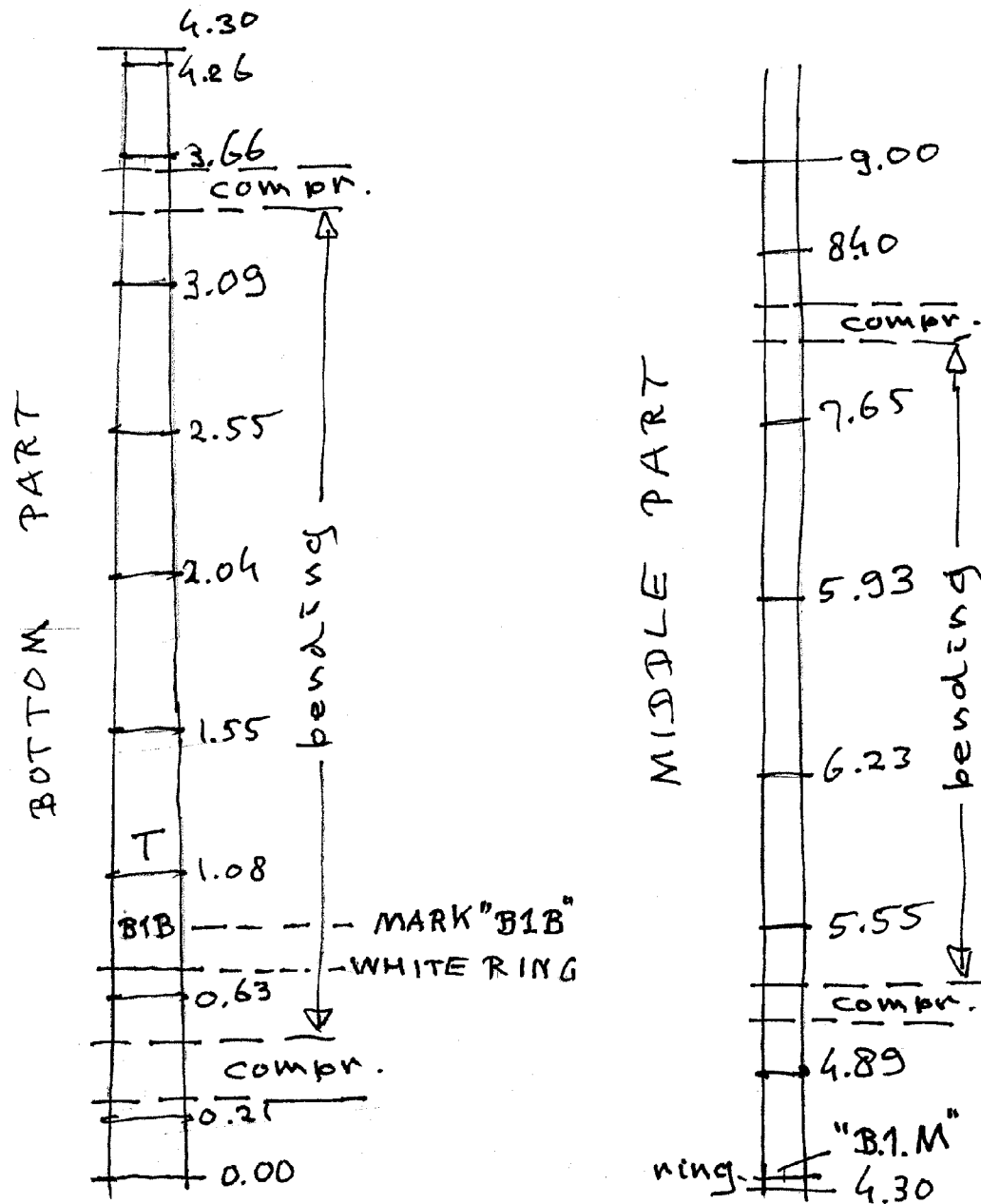

Figure 3 — Sketch of a culm (see 4.2.1 and 5.3)

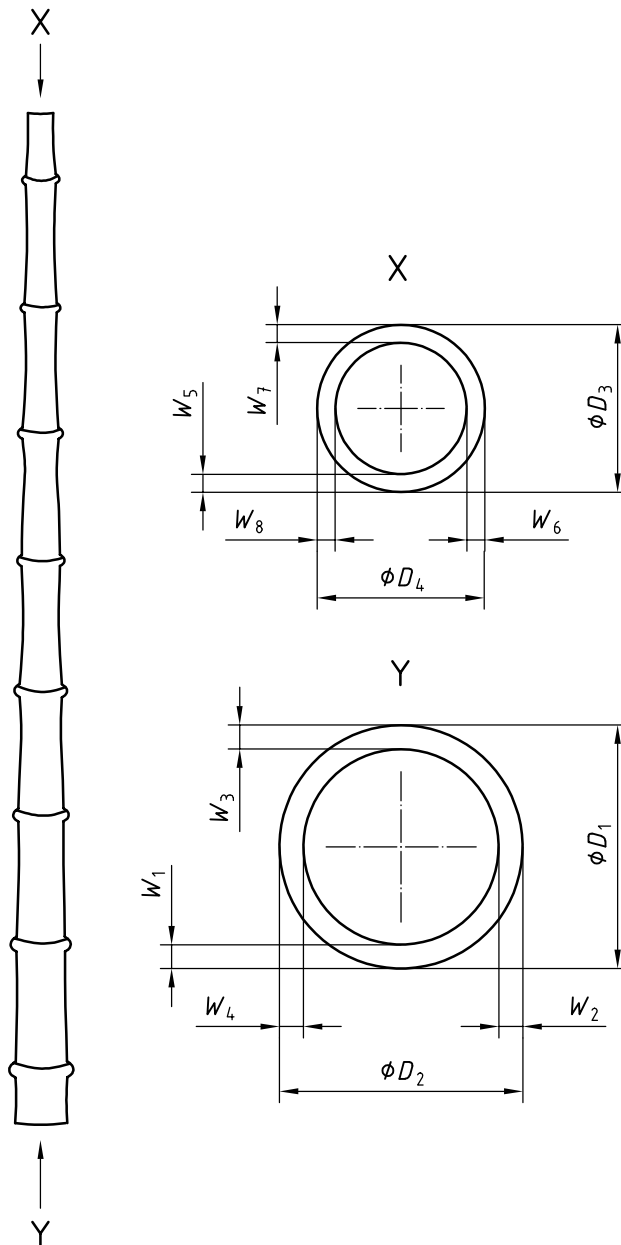

Figure 4 — Diameter and wall thickness of a culm (see 4.2.1 and 10.5.1)

## 5.6 Marking and conversion into test specimens

The number of specimens should be twelve: the purpose of tests is to predict a property for the whole population, with tests on one sample only. The more specimens are taken from the sample, the more reliable is the prediction, but the more expensive as well is the test series. A fair equilibrium exists when the minimum number of test specimens is twelve.

In a test series, we would like to determine the mean value  $\mu$  of the population (pronounce “muu”) but we actually determine the mean value  $m$  of the sample. The formula is:

$$\mu = m - t(s/n)$$

(In the original full formula “+” and “-” are both present, but here we are interested in the “-” only.)

where

- $\mu$  is the mean value of the population;
- $m$  is the mean value of the sample;
- $t$  is the coefficient from Student's distribution;<sup>1)</sup>
- $s$  is the standard deviation;
- $n$  is the number of specimens in the sample.

The result is:

if  $n = 4$  then  $\mu = m \pm 23,5 \%$

if  $n = 8$  then  $\mu = m \pm 13,4 \%$

if  $n = 12$  then  $\mu = m \pm 10,6 \%$

if  $n = 16$  then  $\mu = m \pm 8,8 \%$

The same variation is presented in Figure 5, top curve.

A similar formula is valid for the standard deviation of the population  $\sigma$  as a function of the standard deviation  $s$  of the sample:

if  $n = 4$  then  $0,62s < \sigma < 2,92s$

if  $n = 8$  then  $0,71s < \sigma < 1,80s$

if  $n = 12$  then  $0,75s < \sigma < 1,55s$

if  $n = 16$  then  $0,75s < \sigma < 1,44s$

This can be seen in Figure 5, bottom curve.

NOTE The above is background information to ISO 22156:2004, 7.2.1.

---

1) Student's distribution is a statistical distribution, published by the Englishman W.S.Gosset under the pseudonym "Student".

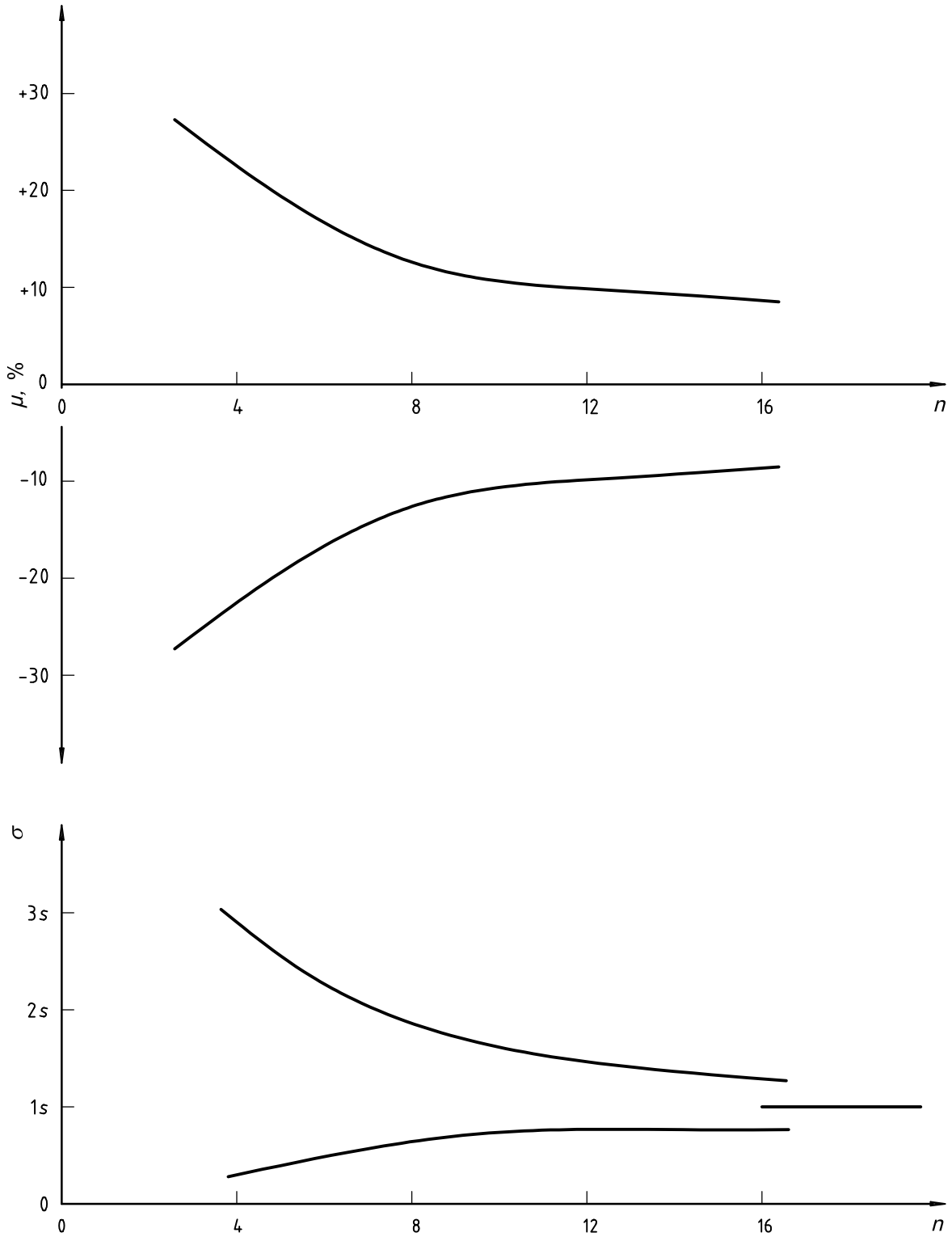

$\mu$  as function of  $n$   
 $\sigma$  as a function of  $n$

**Figure 5 — The relationship between  $\mu$ ,  $\sigma$  and  $n$**

## 6 Moisture content

### 6.3 Apparatus

The glass flasks will be needed only if the test pieces are not put on the balance immediately after preparation, or if they are left out of the oven for some time during or after drying. If one weighs the pieces immediately, no problems will be expected.

### 6.4 Preparation of test specimen

**EXAMPLE** A test piece is 25 mm high, 25 mm wide, and the wall thickness is 10,0 mm. The mass is 5,00 g. (This means that the mass per volume is 800 kg/m<sup>3</sup>.) If we suppose the dry weight is 4,46 g, then the calculation of the moisture content will be:

$$MC = \frac{m - m_o}{m_o} \times 100 = (5,00 - 4,46) / 4,46 \times 100 = 12,1$$

where

MC is the moisture content;

*m* is the mass of test piece;

*m<sub>o</sub>* is the mass of test piece after drying.

as in ISO 22157-1.

## 7 Mass by volume

### 7.1 Scope

“Mass by volume” is the alternative name for “density”.

### 7.4 Preparation of test pieces

Test pieces can be prepared as for moisture content in 6.4, or from a full cross-section of a culm. This last choice leaves open the opportunity to prepare a full internode, the dimensions of which can be measured easily, or of a full node, the dimensions of which can be determined by immersion in water only. It is recommended to make a carbon impression of both ends of each test piece on the data sheet, before and after drying. Attention should be given to the differences which can occur in mass per volume between specimens from the bottom, middle and top part of a culm.

### 7.5 Procedure

The volume can be determined by three methods.

- If the test piece is like a prism, dimensions can be measured with a Vernier calliper, or the volume can be measured in a mercury volume-meter.
- If the test piece is like a cylinder (a ring from an internode), dimensions can be measured as in 4.2.1, or the volume can be measured in a water volume-meter.
- If the test piece is from a node, the volume can be measured by immersion in a water volume-meter only.
- It is not recommended to cover the ends with paraffin or a similar cover before immersion in water; immersion will last a few seconds only, and the penetration of water in bamboo during such a short time can be neglected.

An efficient procedure for the immersion of an internode is as follows.

- Determine the mass,  $m$ , in g.
- Put the balance on top of a bath with 40 l of water at 25 °C; do not worry about this temperature; the error in the mass by volume of the water is only 3 ‰ per 10 °C difference in temperature.
- Determine the weight  $W$ , in g, of the equipment with which the test piece is submerged under water.
- Put the test piece under water and read on the balance the weight under water,  $W_u$ , in g (equipment plus bamboo).
- Calculate the volume  $V_t$ , in cm<sup>3</sup>, of the test piece with this formula:

$$V_t = m - W_u + W$$

An example is as follows.

Basically, the procedure is: what do we measure, and what do we calculate?

Before the test, we already know the weight  $W$  of the equipment with which the test piece is submerged under water, 400 g. This is a constant in the laboratory.

We measure:

The mass  $m$  of the piece of bamboo: 175 g.

The weight  $W_u$  of the test piece plus the equipment under water: 325 g.

We calculate:

The volume =  $m - W_u + W = 175 - 325 + 400 = 250 \text{ cm}^3$  (this could be a piece of bamboo of, for example, 100 mm diameter, 100 mm long and wall thickness 8 mm).

The mass by volume is  $175 \text{ g}/250 \text{ cm}^3 = 700 \text{ kg/m}^3$

The explanation of the weight  $W_u$  is as follows. The weight of the piece of bamboo under water is:

$$250 \text{ cm}^3 \times (1\,000 - 700) \text{ kg/m}^3 = 75 \text{ g, upwards. From which } W_u = 400 - 75 = 325 \text{ g}$$

See Figure 6.

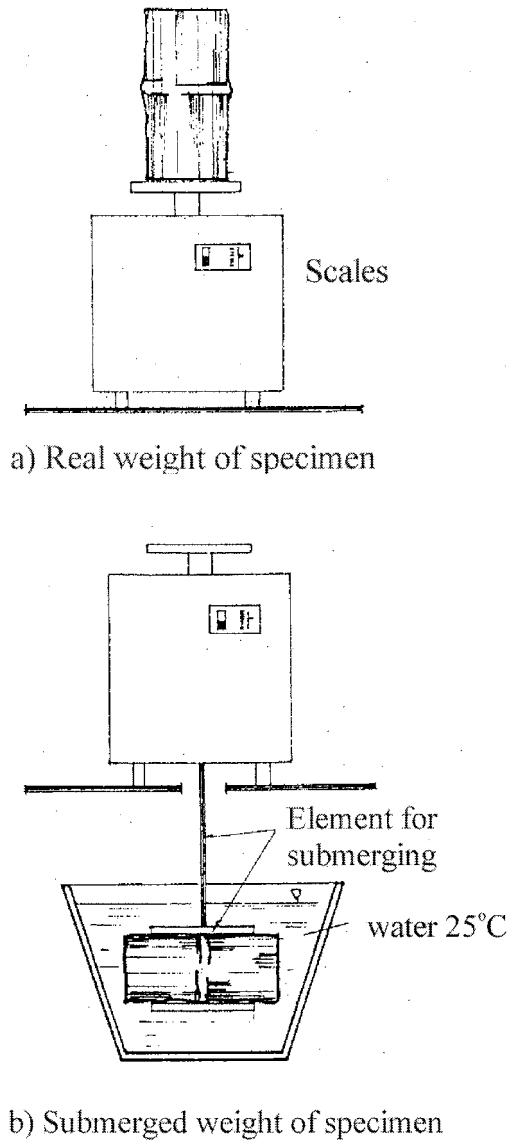

Figure 6 — Determining the volume by immersion (Sotela, 1990)

## 7.6 Determination in the absolutely dry condition

Especially with test pieces with a node, splitting cannot be avoided. In this case, it is recommended to use small test pieces only, instead of full cross-sections.

## 8 Shrinkage

### 8.5.2 Procedure

The measurements could be taken according to Figure 4. The results can be recorded in a table like that in Figure 7.



SPECIES..... FROM .....

Project No. .... Clump No. ....

.....

Consignment No..... Disposition of node..... Age..... No. of  
culm .....

Date	Weight in Grams	Length (cm)	Diameter (cm)	Thickness of Wall (cm)	Moisture content at beginning of test
$A_1-A_2$		$B_1-B_2$ Average shrinkage%	$A_1-B_1$ $C_1-D_1$ $A_2-B_2$ $C_2-D_2$ Average shrinkage%		$A_1B_1C_2D_2$ Average shrinkage%

Figure 7 — Table to record data from tests on shrinkage, (from I.S 6874:1973, appendix C)

## 9 Compression

### 9.3 Apparatus

The intermediate layer to reduce friction between the steel platens and the bamboo specimen requires explanation, because this is not required in any standard for testing timber.

If we perform tests on timber or on bamboo, we have a compressive stress  $\sigma$  and of elasticity  $E$  modulus. The vertical strain (shortening) is  $\varepsilon = \sigma/E$ . With a Poisson's value (the ratio between vertical shortening and horizontal widening) of  $\nu$ , the horizontal strain  $\varepsilon_h = \nu \times \sigma/E$ .

If we do a compression test on a bamboo culm with an outer diameter  $D$  of 100 mm and a wall thickness  $t$  of 7 mm, the horizontal displacement of the outside is  $\varepsilon_h$  multiplied by the radius of 50 mm, or  $50\varepsilon_h$ ; for the inside this is  $43\varepsilon_h$ . If we do this test on a piece of timber with the same cross-section, we have a solid cylinder with an external radius of 25 mm. The horizontal displacement varies between zero in the centre, and  $25\varepsilon_h$  on the outside; the mean value is 2/3 of these, or  $17\varepsilon_h$ . This means that there is a difference of nearly 3 times between bamboo and timber. If a test piece of 20 mm square is prescribed, the difference increases by a factor 6 or 7.

Remarkably, this phenomenon was already understood as early as 1923 by Meyer and Ekelund. They describe their tests on compression: three specimens with 1,5 mm lead on both ends of the specimens, and four specimens with direct contact between the bamboo and the steel platens. The last proved to be 20 % stronger due to "the increased friction at the ends". This knowledge remained hidden till Arce rediscovered it in 1991 (Arce 1993, appendix B).

ISO 22157-1 gives, in Figure 2, an example of a good solution; other solutions to reduce the friction between bamboo and steel platens are lead (as above), and dipping the ends of the bamboo specimens into melted sulfur.

### 9.4 Preparation of test specimens

The statement that the length of the specimen should be equal to the diameter (and not related to the wall thickness as in IS 6874) is based on research by Arce (loc.cit., pp. 43-52)

Tests on compression are prescribed on internodes only, because these specimens are more simple than nodes, and there is no significant difference between test results on compression on nodes and internodes (this means: there is a small difference, but this is smaller than the standard deviation. In some species however, a difference might be found if the pith layer has been removed in the nodes).

### 9.6.2 Range of readings

The range of 20 % to 80 % is based on the linear elastic behaviour of bamboo till very close to failure; this is different from wood.

## 10 Static bending

### 10.1 Scope

This clause refers to full culms only, because bending tests on split bamboos show a completely different behaviour. See Figure 8, and note the completely different bending moments in the cross-section of a full culm, compared with the bending moment in the cross-sections of split bamboos.

### 10.3 Apparatus

The bending test should be a four-point test, because a three-point bending test is much less reliable. See Figure 9, and compare the area of pure bending moment in the four-point test with the complicated stress-situation in the centre of the span in the three-point test. The lowest diagram in this figure shows the influence of the four wooden saddles on the bending moments, which is really negligible.

### 10.4 Preparation of test culms

The purpose of the minimum free span of the culm is to avoid failure by a transverse force instead of by a bending moment. If the free span is too short, the culm will behave like an arch, and will fail due to transverse forces. However, our goal is to determine the bending capacity. The formula for the minimum free span is based on research by Vaessen and Janssen:

$$L = (1,76 \times \varepsilon_{ult} \times E_R \times R) / \tau_{ult}$$

where

$L$  is the free span in mm;

$\varepsilon_{ult}$  is the ultimate longitudinal strain for bamboo;

$E_R$  is the modulus of elasticity (Young's modulus) on the outer skin of the culm;

$R$  is outer radius, in mm, half the outer diameter;

$\sigma_{ult}$  is the ultimate tangential stress.

If the mentioned parameters are unknown, one can use the following default values:

for  $\varepsilon_{ult}$  0,003 2,

for  $E_R$  1,5 times the nominal value of  $E$  as in the compression test,

for  $\tau_{ult}$  2,6 N/mm<sup>2</sup>.

If  $E = 16\ 000$  N/mm<sup>2</sup>, the outcome will be:

$$L = (1,76 \times 0,003\ 2 \times 24\ 000 \times R) / 2,6 = 52R \text{ or } 26D$$

and from this estimate that the minimum length has been prescribed as  $30D$ .

#### 10.5.1 Moment of inertia (see 10.5.4)

The moment of inertia  $I$  is determined twice, once before the test (10.5.1) and once after (10.5.4). The value of  $I$  before is used to predict behaviour during test: one can estimate the maximum values of the deflection and the load, and compare these with the capacity of the machine. After the test,  $I$  is determined from the diameter

$D$  and wall thickness  $t$  near the two points where the load is applied because this value is more representative for the part of the culm with the pure bending moment.

**10.5.2 Procedure**

Once the culm is in its position, mark the upper side of the culm with, for example, a pencil; otherwise it will not be possible to determine which side was up during the test.

**10.5.3 E-modulus**

In most cases, a linear part of the load-deformation diagram can be found between 20 % and 80 % of the ultimate strength.

ISO 22157-1 uses the formula 23/1296; ISO 3349 does not use 23/1296 but 1/36, which is the deflection of the mid third part, obviously to avoid the deflection by shear, but this does not make sense because shear is included in “ $\delta$ ”. Anyhow, deflection by shear can be neglected in the case of bending tests on bamboo culms: the influence on the deflection is less than 5 %, presumably even much less.

Figure 10 gives an example of a table to be used in the laboratory to record the data during the test, and a possible way how to use such a table. Evidently this is an example only; everybody is free to design similar (or better) data sheets.

Figure 11 shows a good example from practice: the bending machine is too short to test long bamboo culms, and how the staff have added a steel beam to solve this problem.

Figure 12 shows a data sheet from the same laboratory, as an alternative to Figure 10.

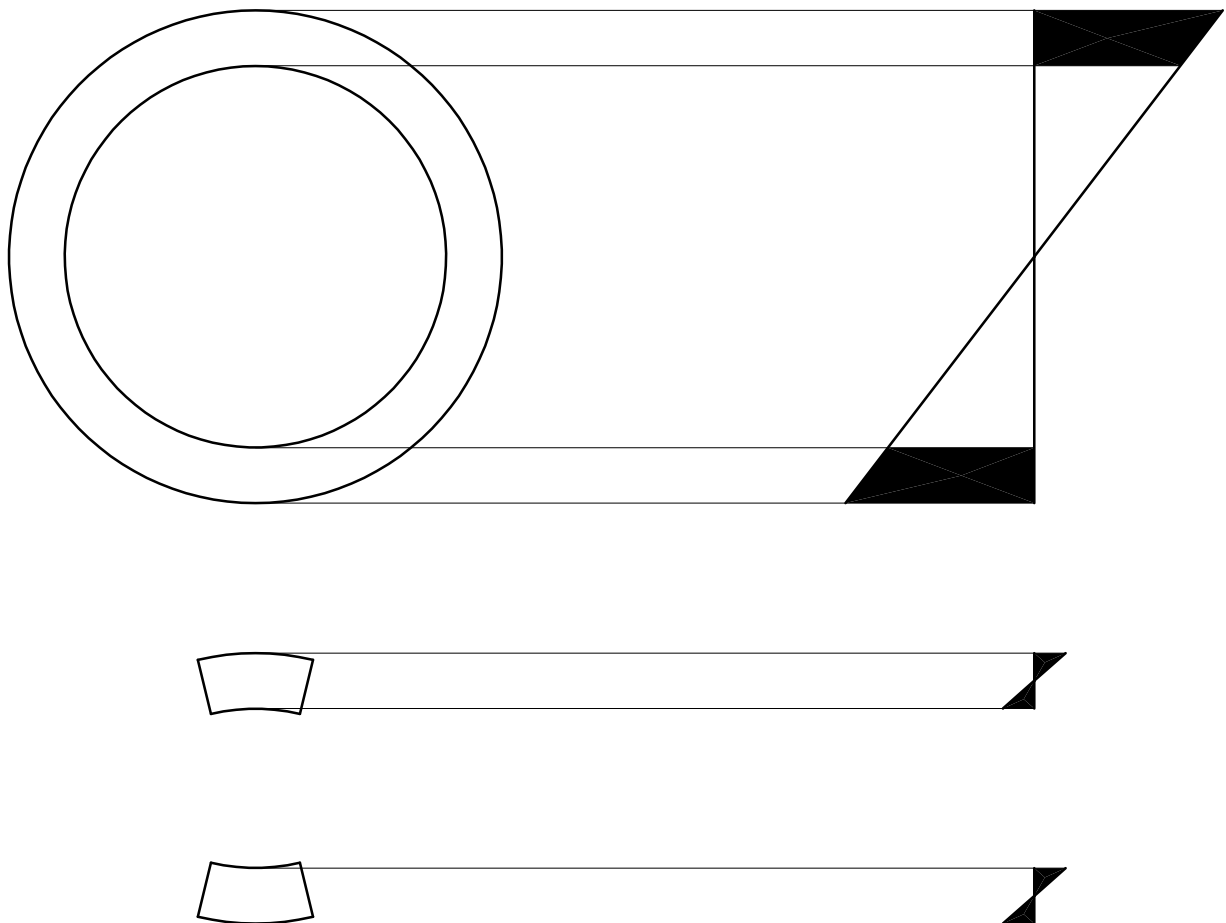

**Figure 8 — Bending moments in full culms and in split bamboos**

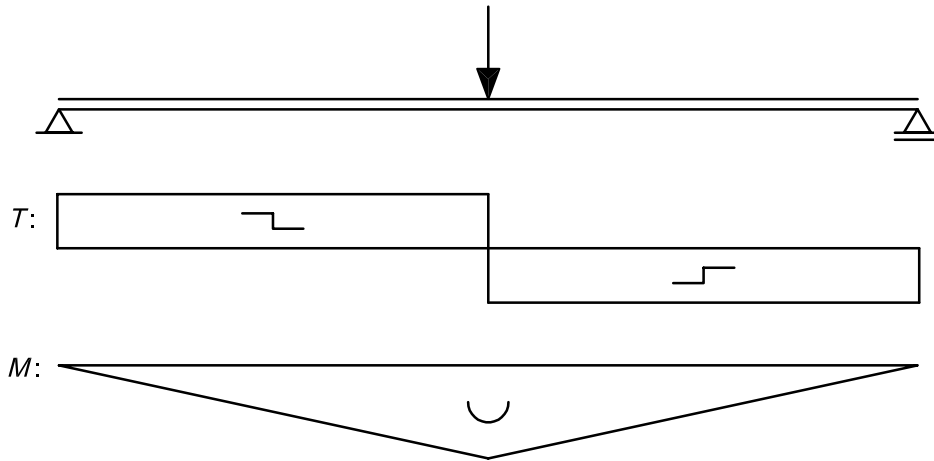

a) Three-point bending test

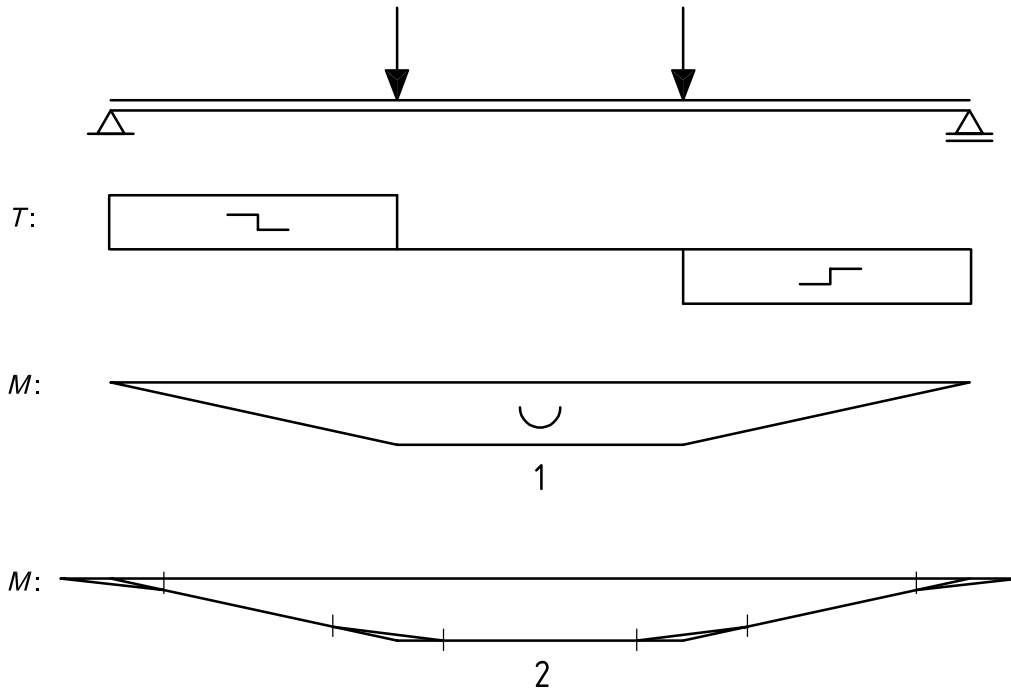

b) Four-point bending test

**Key**

- T*: Transversal force
- M*: Bending moment
- 1 Without saddles
- 2 With saddles

**Figure 9 — Diagram of bending moments and shear forces in a three-point and a four-point bending test**

Name of lab etc.

Short term bending test.

Date: 1998.02.12

Culm mark: 57 D

Drawing of the culm with nodes, position in the bending test, and places where D and d have been taken:

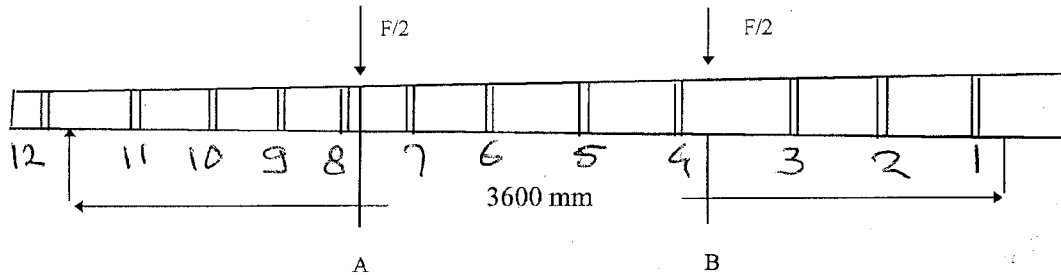

time	load F in N	deflection. δ in mm
11.22 AM	0	0
11.22	500	11
11.24	1000	27,5
11.26	1500	44,5
11.27	2000	64
11.28	2500	81
11.29	3000	104
11.31	3500	130
	3650	failure at 8

\* settles at 700 N

place	D in mm	d in mm	I in mm <sup>4</sup>
A	91,2	91,1	77,3
B	94,4	93,9	78,1

$$M_{ult} = 0.5F_{ult} * 1200 \text{ mm} = 600 * 3650 = 2,19 * 10^6 \text{ Nmm}$$

$$\sigma = M * e / I = \frac{2,19 * 10^6 * 91,15 / 2}{1,85 * 10^6} = 54 \text{ N/mm}^2$$

$$E = \frac{0.5FL^3}{28,17 * \delta * I} = \frac{2000 * 3600^3}{56,34 * 70 * 1,85 * 10^6} =$$

from 500 to 2000 N!

$$12800 \text{ N/mm}^2$$

Figure 10 — Example of a data sheet

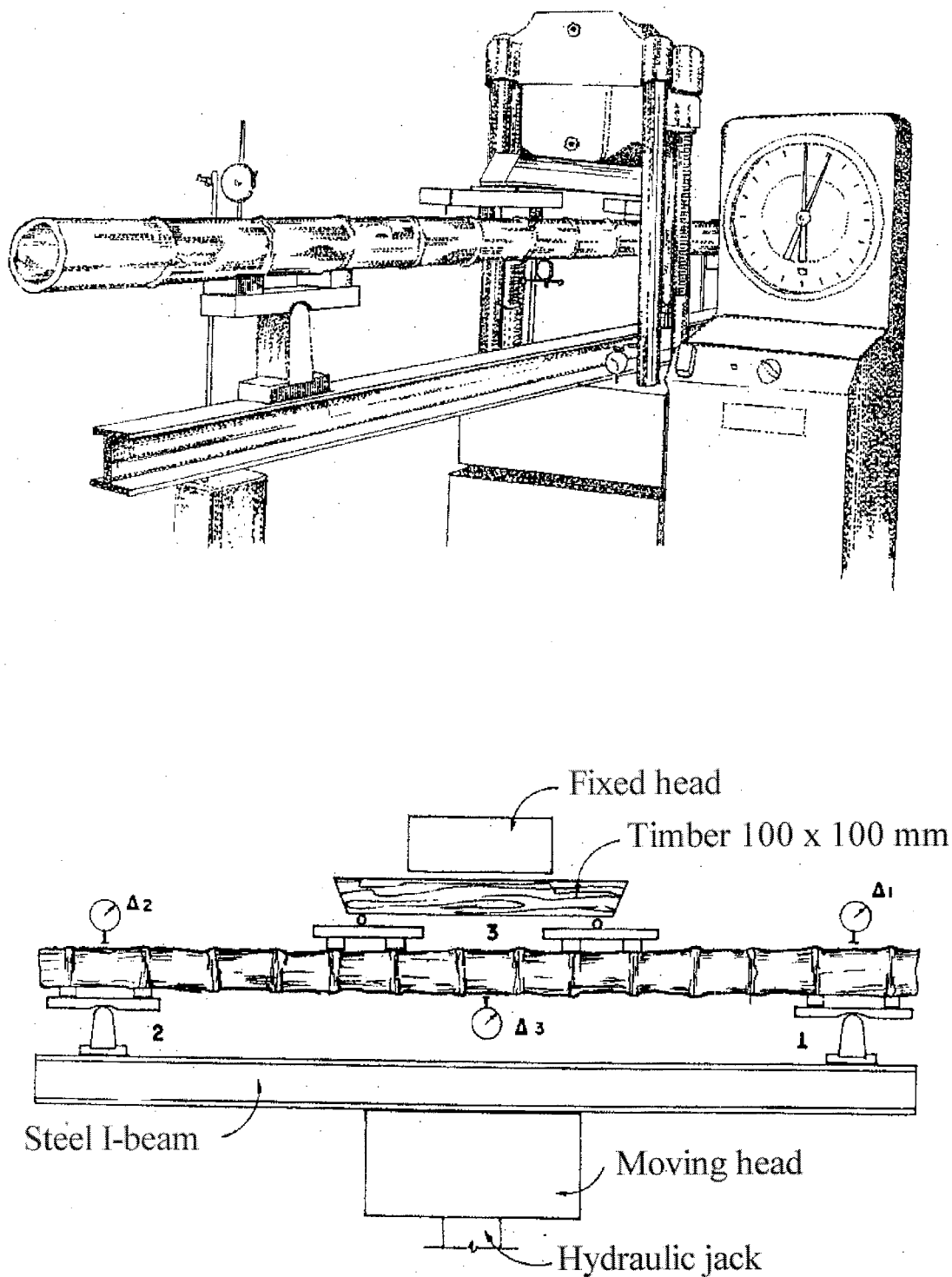
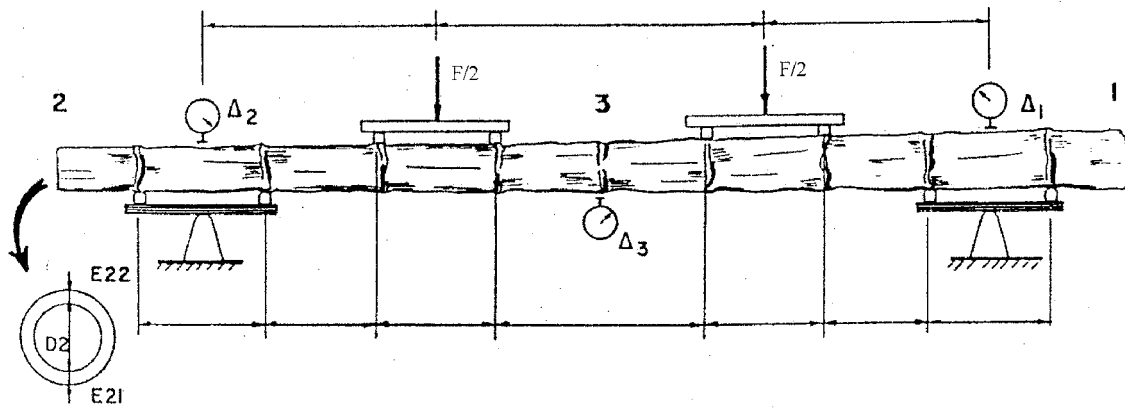

Figure 11 — A bending machine, with an added steel beam (Sotela 1990)

BAMBOO BENDING TEST  
 Species : .....



Date: \_\_\_\_\_ Sample No. \_\_\_\_\_ Condition: \_\_\_\_\_  
 Diameter: D1: \_\_\_\_\_ D2: \_\_\_\_\_ D3: \_\_\_\_\_  
 Wall thicknesses: E11: \_\_\_\_\_ E12: \_\_\_\_\_ E21: \_\_\_\_\_ E22: \_\_\_\_\_ E31: \_\_\_\_\_ E32: \_\_\_\_\_  
 Humidity: W1: \_\_\_\_\_ W2: \_\_\_\_\_ W3: \_\_\_\_\_

Load F ( )	$\Delta$ _____ ( )

Load F ( )	$\Delta$ _____ ( )

Responsible : \_\_\_\_\_

Figure 12 — Data sheet as alternative to Figure 10 (Sotela 1990)

## 11 Shear

### 11.1 Scope

Tests on shear are important for calculation of joints. Tests are prescribed parallel to the fibres; test perpendicular to the fibres would be done for scientific reasons only, for which no standard is necessary.

Figure 4 in ISO 22157-1 shows a distance of 3 mm between the sides of the steel plates on top and bottom; this is a safety precaution, to be sure that a shear area remains between the steel plates. Instead of steel, hardwood can be used as well.

It is good laboratory practice to add a guide, as in Figure 13, otherwise man-made errors will occur.

The test method described in ISO 22157-1 was selected after comparative tests which showed this method to be more reliable (and simple as well) than other test methods and forms of specimens (Janssen 1981).

#### 11.4.2 Specimens

The 50-50 % division between nodes and internodes is based upon the experience that internode specimens behave better in shear than nodes. If we take 12 specimens, we can determine the mean value for all 12, and if we use 6 specimens with a node and 6 without, we can determine the influence of this difference.



Figure 13 — Guided supporting and loading device for shear test (*continued*)



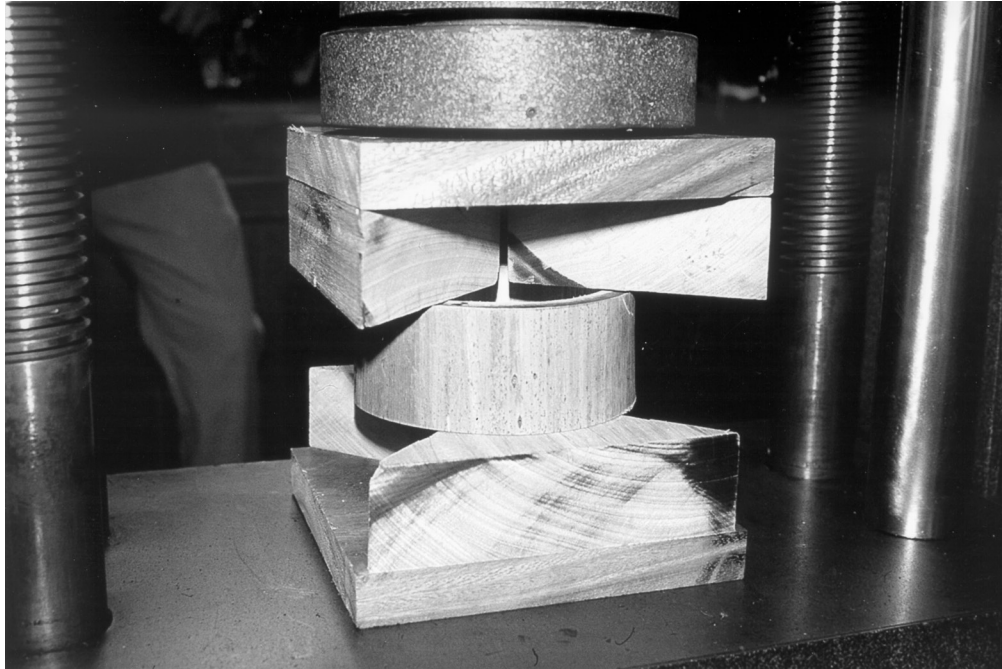

Figure 13 — Guided supporting and loading device for shear test

## 12 Tension

### 12.4.2 Specimens

Here, the specimens must have a node: the difference in results in tension between specimens with and without a node is tremendous; a node really is weak in tension. The tensile strength of a node region is only 30 % of an internode region (Arce, 1993, p. 111). For commercial purposes, a node is prescribed here; for scientific research one is free to do otherwise.

If one likes to calculate the tensile strength for a complete culm, based on tensile tests as described here, one has to keep in mind not only the said weakness of each node, but also the fact that, in nodes, the places where branches did sprout are even more weaker.

### 12.4.4 Form of the specimens

Three examples are given:

- Figure 14, a wedge-shaped test piece, in use in many laboratories; many problems with failure in shear are known with this type of specimen (Zhou Fangchun 1981);
- Figure 15 shows a test piece with glued wooden pieces on both ends. The length of these is determined by the allowable shear stress in this glue joint (Arce 1993);
- Figure 16 shows a test piece which is used in Japan (courtesy Prof. Inoue).

NOTE This one (Figure 16) prefers not to have a node in the test area, contrary to ISO 22157-1.

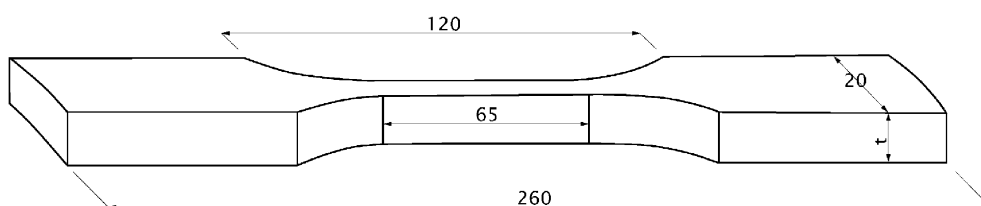

Figure 14 — Wedge-shaped test piece for tension tests

NOTE The curvature of the specimen depends on the diameter of the bamboo culm.

Dimensions in millimetres

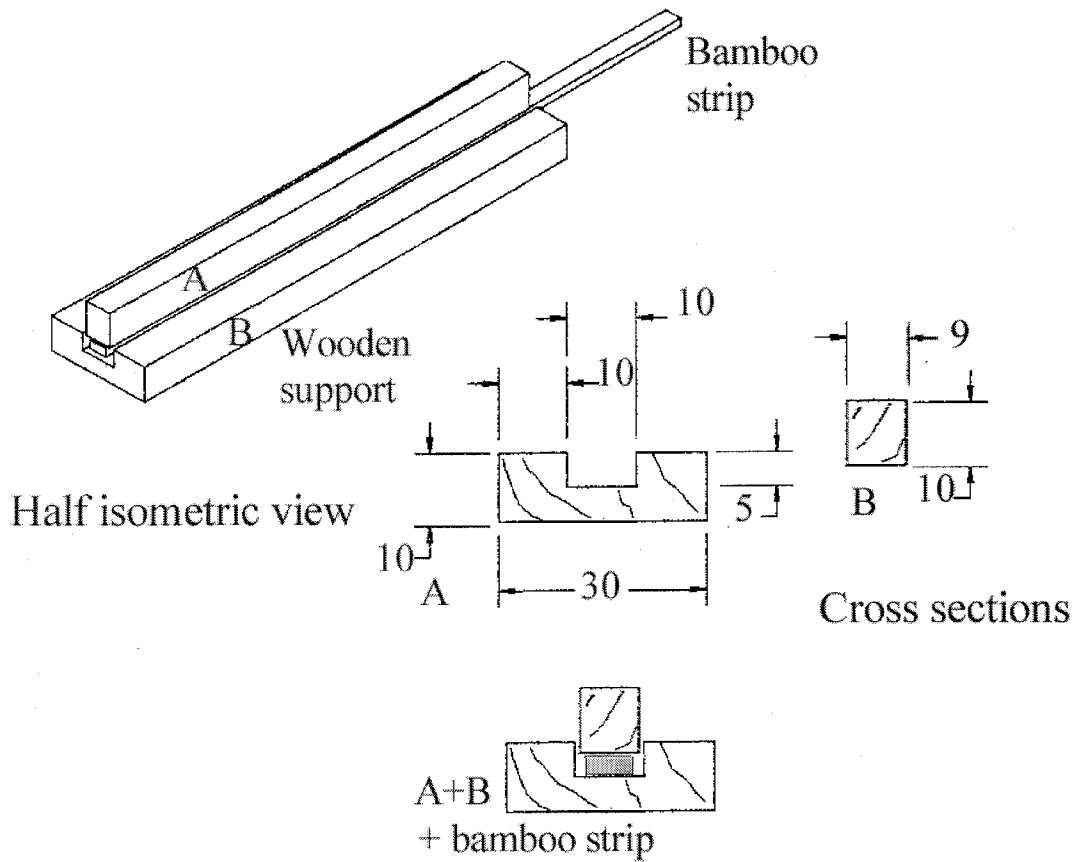
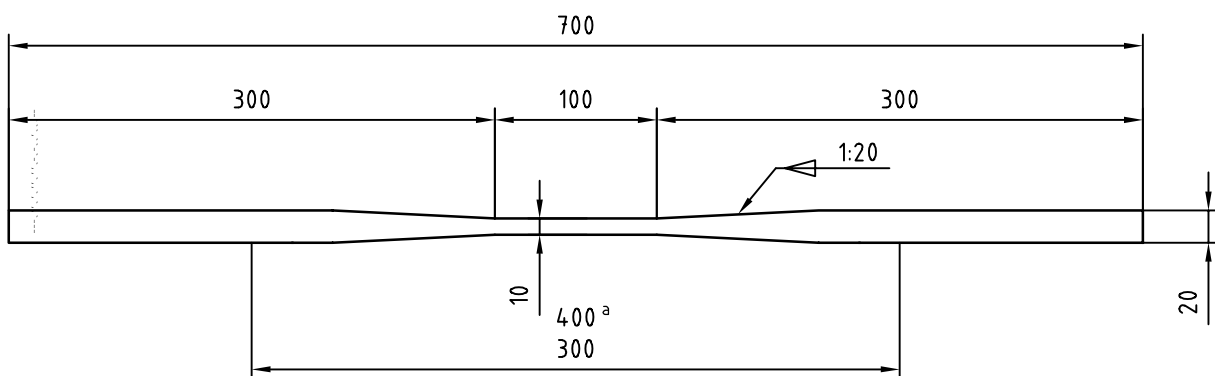

Figure 15 — Tensile test piece with wooden ends

Dimensions in millimetres



<sup>a</sup> Distance between nodes.

Figure 16 — Test piece for tension tests

## Bibliography

- [1] ISO 22156:2004, *Bamboo — Structural design*
- [2] ARCE, O. (1993) *Fundamentals of the design of bamboo structures*. Thesis Eindhoven University, 260 pp. ISBN: 90-6814-524-X. Also available from the website [www.tue.nl](http://www.tue.nl)
- [3] MEYER, H.F., and EKELUND B., (1923) *Tests on the mechanical properties of bamboo*, paper 7, vol 22, The Engineering Society of China, session 1922-1923, pp 141-169
- [4] VAESSEN, M.J., and JANSSEN J.J.A., (1997), Analysis of the critical length of culms of bamboo in four-point bending tests. *Heron*, vol. 42 No. 2, pp. 113-124. ISSN 0046 7316
- [5] ZHOU FANGCHUN, 1981. *Studies on physical and mechanical properties of bamboo woods*. *Journal of Nanjing Technological College of Forest Products*, No. 2. (in Chinese). (wedge-shaped test piece for tension tests)
- [6] SOTELA, 1990. *Manual de ensayos fisico-mecanicos para especimenes de bambu*. Laboratorio de productos forestales, Instituto de investigaciones en ingenieria, Universidad de Costa Rica. (in Spanish)
- [7] JANSSEN, 1981, *Bamboo in building structures*. Thesis Eindhoven University. Also available from [www.tue.nl](http://www.tue.nl)

.....

---

---

**ICS 79.040**

Price based on 21 pages