**Destructive tests on welds in metallic
materials — Hardness testing —**

Part 2:
Microhardness testing of welded joints

*Essais destructifs des soudures sur matériaux métalliques — Essais de
dureté —*

Partie 2: Essai de microdureté des assemblages soudés



COPYRIGHT PROTECTED DOCUMENT

© ISO 2016, Published in Switzerland

All rights reserved. Unless otherwise specified, no part of this publication may be reproduced or utilized otherwise in any form or by any means, electronic or mechanical, including photocopying, or posting on the internet or an intranet, without prior written permission. Permission can be requested from either ISO at the address below or ISO's member body in the country of the requester.

ISO copyright office
Ch. de Blandonnet 8 • CP 401
CH-1214 Vernier, Geneva, Switzerland
Tel. +41 22 749 01 11
Fax +41 22 749 09 47
copyright@iso.org
www.iso.org

Contents

Page

Foreword	iv
1 Scope	1
2 Normative references	1
3 Symbols and abbreviated terms	1
4 Principle	2
5 Preparation of test specimens	2
6 Test procedure	2
6.1 Rows of indentations (R)	2
6.2 Individual indentations (E)	3
7 Test results	3
8 Test report	3
Annex A (informative) Example of a test report for rows of hardness tests (R) on welded joints	6
Annex B (informative) Example of a test report for individual hardness tests (E) on welded joints	7
Bibliography	8

Foreword

ISO (the International Organization for Standardization) is a worldwide federation of national standards bodies (ISO member bodies). The work of preparing International Standards is normally carried out through ISO technical committees. Each member body interested in a subject for which a technical committee has been established has the right to be represented on that committee. International organizations, governmental and non-governmental, in liaison with ISO, also take part in the work. ISO collaborates closely with the International Electrotechnical Commission (IEC) on all matters of electrotechnical standardization.

The procedures used to develop this document and those intended for its further maintenance are described in the ISO/IEC Directives, Part 1. In particular the different approval criteria needed for the different types of ISO documents should be noted. This document was drafted in accordance with the editorial rules of the ISO/IEC Directives, Part 2 (see www.iso.org/directives).

Attention is drawn to the possibility that some of the elements of this document may be the subject of patent rights. ISO shall not be held responsible for identifying any or all such patent rights. Details of any patent rights identified during the development of the document will be in the Introduction and/or on the ISO list of patent declarations received (see www.iso.org/patents).

Any trade name used in this document is information given for the convenience of users and does not constitute an endorsement.

For an explanation on the meaning of ISO specific terms and expressions related to conformity assessment, as well as information about ISO's adherence to the WTO principles in the Technical Barriers to Trade (TBT) see the following URL: [Foreword - Supplementary information](#)

The committee responsible for this document is ISO/TC 44, *Welding and allied processes*, Subcommittee SC 5, *Testing and inspection of welds*.

This second edition cancels and replaces the first edition (ISO 9015-2:2003), of which it constitutes a minor revision.

ISO 9015 consists of the following parts, under the general title *Destructive tests on welds in metallic materials — Hardness testing*:

- *Part 1: Hardness test on arc welded joints*
- *Part 2: Microhardness testing of welded joints*

Destructive tests on welds in metallic materials — Hardness testing —

Part 2: Microhardness testing of welded joints

1 Scope

This part of ISO 9015 specifies microhardness testing on transverse sections of welded joints of metallic materials with high hardness gradients. It covers Vickers hardness tests in accordance with ISO 6507-1, normally with test loads of 0,98 N to less than 49 N (HV 0,1 to less than HV 5).

NOTE Testing ensures that the highest and/or the lowest level of hardness of both parent materials (in the case of dissimilar materials both parent materials) and weld metal is determined.

This part of ISO 9015 is not applicable to hardness testing of welds with loads of 49,03 N and above, which is covered by ISO 9015-1.

This part of ISO 9015 is not applicable to Vickers hardness testing of resistance spot, projection and seam welds, which is covered by ISO 14271.

This part of ISO 9015 is not applicable to hardness testing of very narrow welds, e.g. those typically produced by laser and electron beam welding (see ISO 22826).

2 Normative references

The following documents, in whole or in part, are normatively referenced in this document and are indispensable for its application. For dated references, only the edition cited applies. For undated references, the latest edition of the referenced document (including any amendments) applies.

ISO 6507-1, *Metallic materials — Vickers hardness test — Part 1: Test method*

3 Symbols and abbreviated terms

The symbols and terms to be used are specified in [Table 1](#) and represented in [Figures 1, 2 and 3](#).

Table 1 — Symbols and abbreviated terms

Symbol	Term	Unit
E	Individual indentation	—
H	Distance of rows of indentations from the reference line (surface or fusion line)	mm
HAZ	Heat affected zone	—
HV	Vickers hardness	— ^a
L	Distance between the centre point of the indentations in the heat-affected zone	mm
R	Row of indentations	—
t	Thickness of test specimen	mm

^a Units for Vickers hardness are given in ISO 6507-1.

4 Principle

Microhardness testing shall be carried out in accordance with ISO 6507-1.

The microhardness tests may be carried out in the form of rows of indentations, R, or as individual indentations, E.

When the type of weld is not shown in the examples, the test procedure shall be appropriate to the welded joint.

In general, the test is carried out at ambient temperature within the limits of 10 °C to 35 °C. Tests carried out under controlled conditions shall be made at a temperature of (23 ± 5) °C.

5 Preparation of test specimens

The preparation of the test specimen shall be in accordance with ISO 6507-1.

A cross-section from the test piece shall be taken by mechanical cutting, usually transverse to the welded joint.

This operation and the subsequent preparation of the surface shall be carried out carefully so that the hardness of the surface to be tested is not affected metallurgically by heat or cold working.

The surface to be tested shall be properly prepared and preferably etched, so that accurate measurements of the diagonal lengths of the indentations can be taken in the different zones of the welded joint.

6 Test procedure

6.1 Rows of indentations (R)

[Figures 1](#) and [2](#) show typical examples for the location of hardness indentations made in rows, including the distance from the surface, so that the rows or parts thereof permit an assessment of the welded joint. If specified, e.g. by reference to an application standard, additional rows of indentations and/or different locations may be made. The actual location(s) shall be included in the test report.

In metals such as aluminium or copper and their alloys, the rows on the root-side of butt welds (see [Figure 1](#)) are not always necessary and may be omitted.

The number and spacing of indentations shall be sufficient to define hardened and/or softened regions due to welding. The recommended distance, *L*, between the centre point of the indentations in the heat-affected zone (HAZ) is given in [Table 2](#) and in ISO 6507-1. The larger dimension, in accordance with [Table 2](#) or ISO 6507-1, should be used.

A sufficient number of indentations shall be made to ensure that unaffected parent material is also tested. The distance between indentations in the weld metal shall be sufficient to enable a full assessment of the welded joint. For metals which, as a result of welding, harden in the HAZ, two additional indentations in the HAZ shall be made at a distance $\leq 0,5$ mm between the centre point of the indentation and the fusion line (see [Figure 2](#)).

For other joint configurations or metals (e.g. austenitic steels) additional indentations may be specified, e.g. by reference to an application standard.

Table 2 — Recommended distance, L , between the centre points of indentations in the heat-affected zone (HAZ) for rows of indentations (R)

Vickers hardness symbol	Recommended distance between indentations, L mm ^a	
	Ferrous metals ^b	Aluminium, copper and their alloys
HV 0,1	0,2	0,6 to 2
HV 1	0,5	1,5 to 4
HV 5	0,7	2,5 to 5

^a The distance between centre points shall not be less than the minimum value allowed in ISO 6507-1.

^b Excluding austenitic steels.

6.2 Individual indentations (E)

[Figure 3](#) shows typical areas for the location of individual indentations: locations 1–4 give information about the unaffected parent material; locations 5–8 refer to the HAZ; locations 9–11 refer to the weld metal. Otherwise, the location of the indentation can be determined on the basis of metallographic examination.

To prevent the influence of deformation caused by an indentation, the minimum distance between the centre point of individual indentations in any direction shall not be less than the value given in ISO 6507-1.

For metals that harden in the HAZ as a result of welding, at least one indentation shall be made in the HAZ with its centre point $\leq 0,5$ mm from the fusion line.

For hardness testing using individual indentations, the areas shall be numbered as shown in [Figure 3](#).

7 Test results

The hardness values shall be recorded in relation to the position of the indentation.

8 Test report

The test results shall be recorded in a test report, which contains at least the following information:

- a) type of hardness test;
- b) identification of the test machine;
- c) parent material;
- d) thickness of the material;
- e) type of weld;
- f) welding process;
- g) consumable;
- h) post weld heat treatment and /or ageing;
- i) any relevant notes;
- j) a picture or drawing, with dimensions if appropriate.

The format given in [Annex A](#) and [Annex B](#) should be used.

Other formats may be used provided they contain all the required information listed in [Annex A](#) and [Annex B](#). Additional information may be required, e.g. by an application standard.

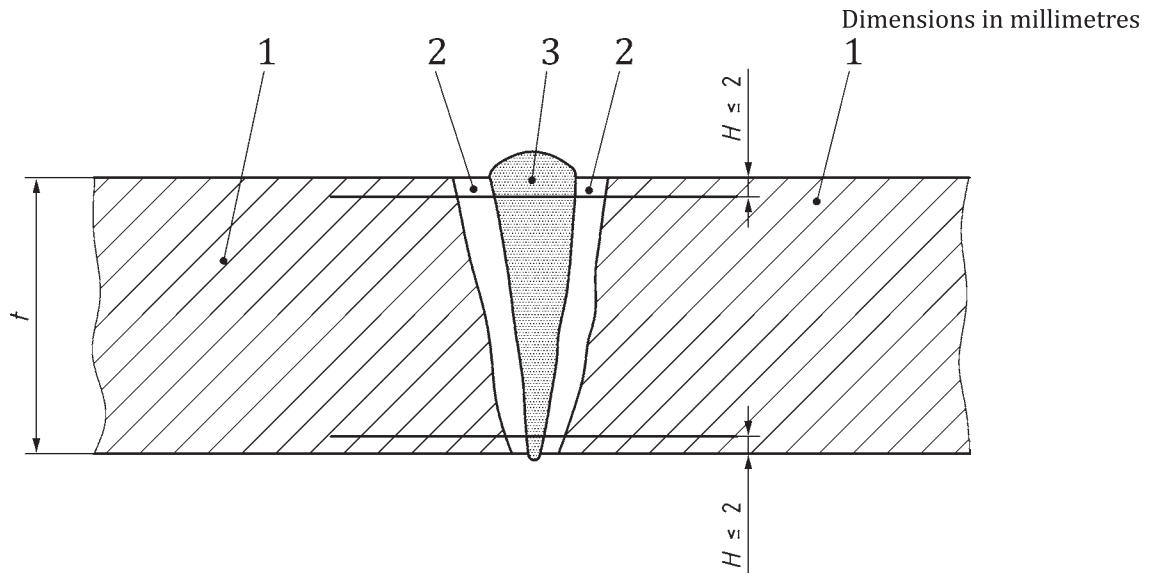

Key

- 1 parent material
- 2 heat-affected zone
- 3 weld metal

NOTE For thickness ≤ 4 mm, the rows of indentations shall be at the mid-thickness position.

Figure 1 — Example of rows of indentation (R) in butt welds in ferrous metals

Dimensions in millimetres

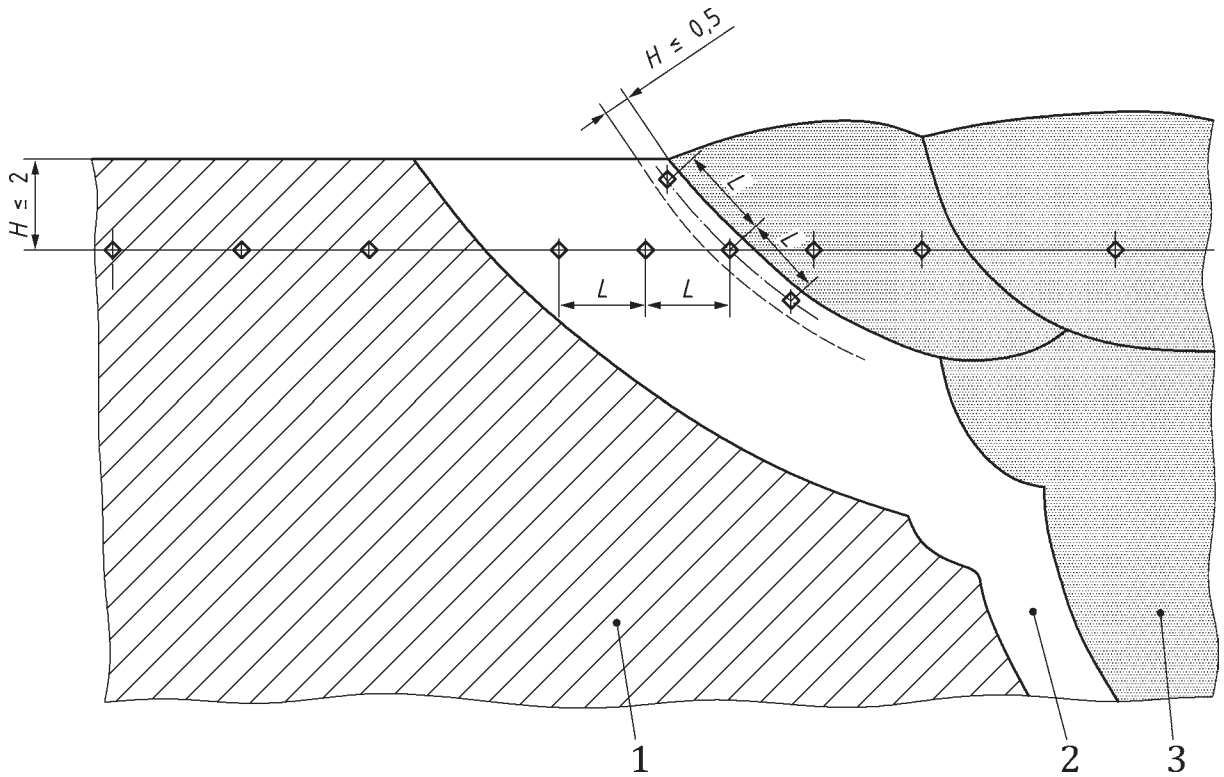

Key

- 1 parent material
- 2 heat-affected zone
- 3 weld metal

Figure 2 — Location of indentations in butt welds in ferrous metals (excluding austenitic steels)

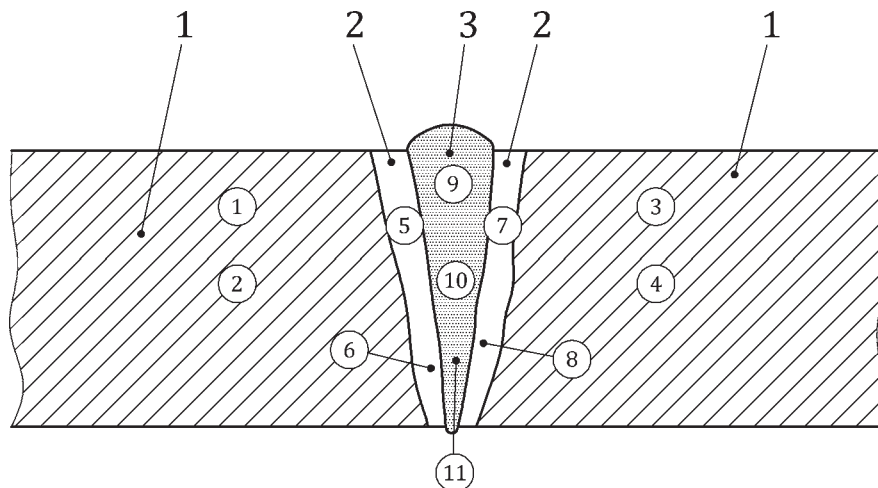

Key

- 1 parent material
- 2 heat-affected zone
- 3 weld metal

NOTE Numbers in circles refer to locations of hardness indentations. Other locations may be specified.

Figure 3 — Example showing areas for hardness testing with individual indentations (E)

Annex A (informative)

Example of a test report for rows of hardness tests (R) on welded joints

Type of hardness test: _____

Identification of the test machine: _____

Parent material: _____

Thickness of material: _____

Type of weld: _____

Welding process: _____

Consumable: _____

Post weld heat treatment and/or ageing: _____

Brief designation of rows of indentations: _____

Notes: _____

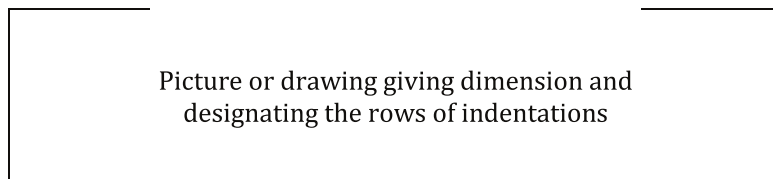

600							
500							
400							
300							
200							
100							

0
Centre of weld
Distance from weld centre (in mm)
= ... (to be completed)

^a Indication of load in accordance with ISO 6507-1.

Annex B (informative)

Example of a test report for individual hardness tests (E) on welded joints

Type of hardness test: _____

Identification of the test machine: _____

Parent material: _____

Thickness of material: _____

Type of weld: _____

Welding process: _____

Consumable: _____

Post weld heat treatment and/or ageing: _____

Notes: _____

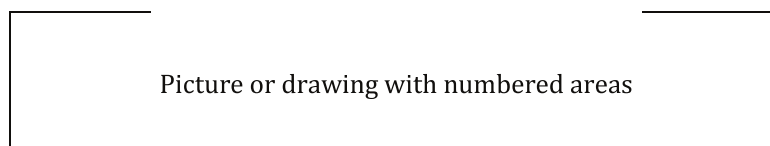

		Area	Position of indentations	Individual hardness values HV ^a
Parent material	Unaffected material	1	Parent material, unaffected, surface	
		2	Parent material, unaffected, centre	
		3	Parent material, unaffected, surface	
		4	Parent material, unaffected, centre	
	Heat affected zone	5	Parent material, heat affected zone, top of weld	
		6	Parent material, heat affected zone, bottom of weld	
		7	Parent material, heat affected zone, top of weld	
		8	Parent material, heat affected zone, bottom of weld	
Weld metal		9	Weld metal, top	
		10	Weld metal, centre	
		11	Weld metal, bottom	
^a Indication of load in accordance with ISO 6507-1.				

Bibliography

- [1] ISO 9015-1, *Destructive tests on welds in metallic materials — Hardness testing — Part 1: Hardness test on arc welded joints*
- [2] ISO 14271, *Resistance welding — Vickers hardness testing (low-force and microhardness) of resistance spot, projection, and seam welds*

