

INTERNATIONAL  
STANDARD

**ISO**  
**7176-11**

First edition  
1992-05-01

---

---

**Wheelchairs —**

**Part 11:**  
Test dummies

*Fauteuils roulants —*

*Partie 11: Mannequins d'essai*



Reference number  
ISO 7176-11:1992(E)

## Foreword

ISO (the International Organization for Standardization) is a worldwide federation of national standards bodies (ISO member bodies). The work of preparing International Standards is normally carried out through ISO technical committees. Each member body interested in a subject for which a technical committee has been established has the right to be represented on that committee. International organizations, governmental and non-governmental, in liaison with ISO, also take part in the work. ISO collaborates closely with the International Electrotechnical Commission (IEC) on all matters of electrotechnical standardization.

Draft International Standards adopted by the technical committees are circulated to the member bodies for voting. Publication as an International Standard requires approval by at least 75 % of the member bodies casting a vote.

International Standard ISO 7176-11 was prepared by Technical Committee ISO/TC 173, *Technical systems and aids for disabled or handicapped persons*, Sub-Committee SC 1, *Wheelchairs*.

ISO 7176 consists of the following parts, under the general title *Wheelchairs*:

- *Part 1: Determination of static stability*
- *Part 2: Determination of dynamic stability of electric wheelchairs*
- *Part 3: Determination of efficiency of brakes*
- *Part 4: Determination of energy consumption of electric wheelchairs*
- *Part 5: Determination of overall dimensions, mass and turning space*
- *Part 6: Determination of maximum speed, acceleration and retardation of electric wheelchairs*
- *Part 7: Determination of seating and wheel dimensions*
- *Part 8: Static, impact and fatigue strength tests for wheelchairs*
- *Part 9: Climatic tests for electric wheelchairs*

© ISO 1992

All rights reserved. No part of this publication may be reproduced or utilized in any form or by any means, electronic or mechanical, including photocopying and microfilm, without permission in writing from the publisher.

International Organization for Standardization  
Case Postale 56 • CH-1211 Genève 20 • Switzerland

Printed in Switzerland

- *Part 10: Determination of obstacle-climbing ability of electric wheelchairs*
- *Part 11: Test dummies*
- *Part 13: Determination of coefficient of friction of test surfaces*
- *Part 14: Power and controls*
- *Part 15: Requirements for information disclosure, documentation and labelling*
- *Part 16: Flammability*
- *Part 17: Serial interface for electric wheelchair controllers*
- *Part 18: Stair traversing devices*

Annex A forms an integral part of this part of ISO 7176.

## Wheelchairs —

### Part 11: Test dummies

#### 1 Scope

This part of ISO 7176 specifies the construction of test dummies with nominal masses of 25 kg, 50 kg, 75 kg and 100 kg, intended for use as specified in other parts of ISO 7176.

The test dummies are so designed that their centres of gravity with respect to a wheelchair under test are located at approximately the same positions as those of an average human being of the same mass seated in the wheelchair.

#### 2 Normative references

The following standards contain provisions which, through reference in this text, constitute provisions of this part of ISO 7176. At the time of publication, the editions indicated were valid. All standards are subject to revision, and parties to agreements based on this part of ISO 7176 are encouraged to investigate the possibility of applying the most recent editions of the standards indicated below. Members of IEC and ISO maintain registers of currently valid International Standards.

ISO 845:1988, *Cellular plastics and rubbers — Determination of apparent (bulk) density*.

ISO 1856:1980, *Polymeric materials, cellular flexible — Determination of compression set*.

ISO 1923:1981, *Cellular plastics and rubbers — Determination of linear dimensions*.

ISO 2439:1980, *Polymeric materials, cellular flexible — Determination of hardness (indentation technique)*.

#### 3 Specification

The four mass classes of the dummy are 100 kg, 75 kg, 50 kg and 25 kg. The main construction of the dummies is shown in figures 1 to 10.

The dummies shall be constructed of

- $(15 \pm 1)$  mm plywood;
- $(30^{+10}_{-5})$  mm  $\times$   $(30^{+10}_{-5})$  mm  $\times$   $(2^{+1,2}_{-0,5})$  mm aluminium angles;
- $(30^{+10}_{-5})$  mm  $\times$   $(2^{+1,2}_{-0,5})$  mm aluminium strips;
- $(30 \pm 10)$  mm  $\times$   $(20 \pm 1)$  mm plastics/nylon units;
- $(30 \pm 10)$  mm  $\times$   $(12 \pm 1)$  mm plastics/nylon units;
- $(240 \pm 5)$  mm  $\times$   $(80 \pm 3)$  mm  $\times$   $(40^{+0}_{-4})$  mm steel plates (approximately 6 kg masses);
- $(240 \pm 5)$  mm  $\times$   $(80 \pm 3)$  mm  $\times$   $(20^{+0}_{-2})$  mm steel plates (approximately 3 kg masses);
- $(15 \pm 3)$  mm, closed-cell, high-density foam:
  - density in accordance with ISO 845:  $(75 \pm 15)$  kg/m<sup>3</sup>,
  - hardness in accordance with ISO 2439:  $(325 \pm 60)$  N,
  - lasting distortion: less than 5 % in accordance with ISO 1856 and ISO 1923;
- $(50 \pm 3)$  mm open-cell rigid foam.

Dimensional tolerances for the main construction shall be as indicated in the drawings.

Other materials and constructions are considered acceptable if the overall dimensions, mass distribution and general characteristics are maintained.

**4 Positioning of dummies in wheelchairs**

The dummy appropriate for the size of the wheelchair shall be secured in the wheelchair during the test. The dummy shall be positioned as far as possible to the back of the seat, equidistant from either side. Where used, the "legs" of the dummy shall be positioned such that the rear edge coincides with the rear edge of the footrest.

When using the dummy for dynamic testing, the steel plates shall be secured in the dummy.

If required in the application of other parts of ISO 7176, an accelerometer shall be mounted as shown in figure A.1.

**5 Test dummies**

5.1 The different total masses of the dummies shall be built up as shown in table 1.

5.2 To enable fitting of the back to the seat (see figures 2 and 3), build the back first, as it gives the priority measurement for fitting the weights. In figures 5 and 6, the dimension adjacent to which is the text "See 5.2" shall be large enough to fit inside the back.

**Table 1 — Make-up of masses of dummies**

Component	Mass class of dummies			
	100 kg	75 kg	50 kg	25 kg
"Trunk"				
Masses	9 × 6 = 54 1 × 3 = 3	7 × 6 = 42	4 × 6 = 24	2 × 6 = 12
Construction	4	4	4	1,5
Subtotals, kg	61 ± 3	46 ± 3	28 ± 3	13,5 ± 2
"Upper legs"				
Masses	4 × 6 = 24 1 × 3 = 3	3 × 6 = 18	2 × 6 = 12	1 × 6 = 6 1 × 3 = 3
Construction	4	4	4	1,5
Subtotals, kg	31 ± 3	22 ± 3	16 ± 3	10,5 ± 2
"Lower legs"				
Masses	1 × 6 = 6	1 × 6 = 6	1 × 6 = 6	
Construction	1	1	1	
Subtotals, kg	7 ± 1	7 ± 1	7 ± 1	
Totals, kg	100 <sup>+5</sup> / <sub>-2</sub>	75 <sup>+5</sup> / <sub>-2</sub>	50 <sup>+5</sup> / <sub>-2</sub>	25 <sup>+4</sup> / <sub>-2</sub>

Dimensions in millimetres

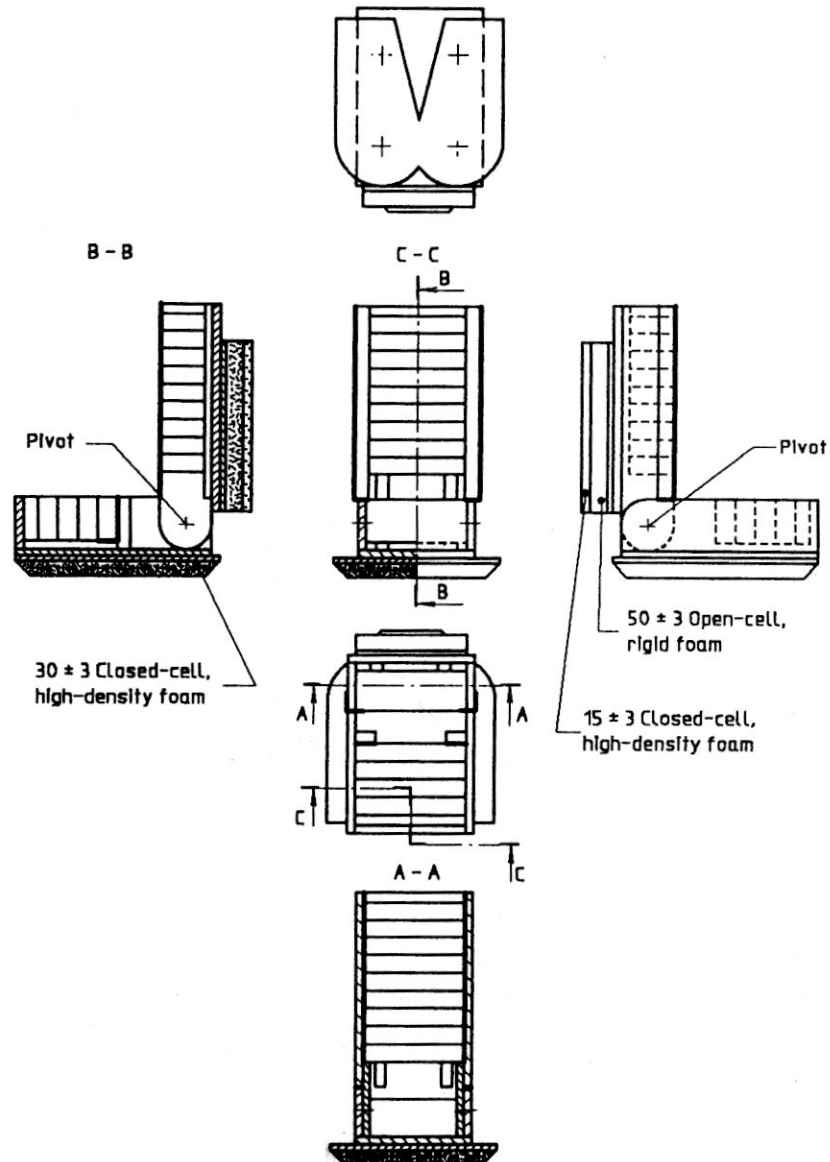

Figure 1 — Test dummy devices of 100 kg, 75 kg and 50 kg: main construction

Dimensions in millimetres

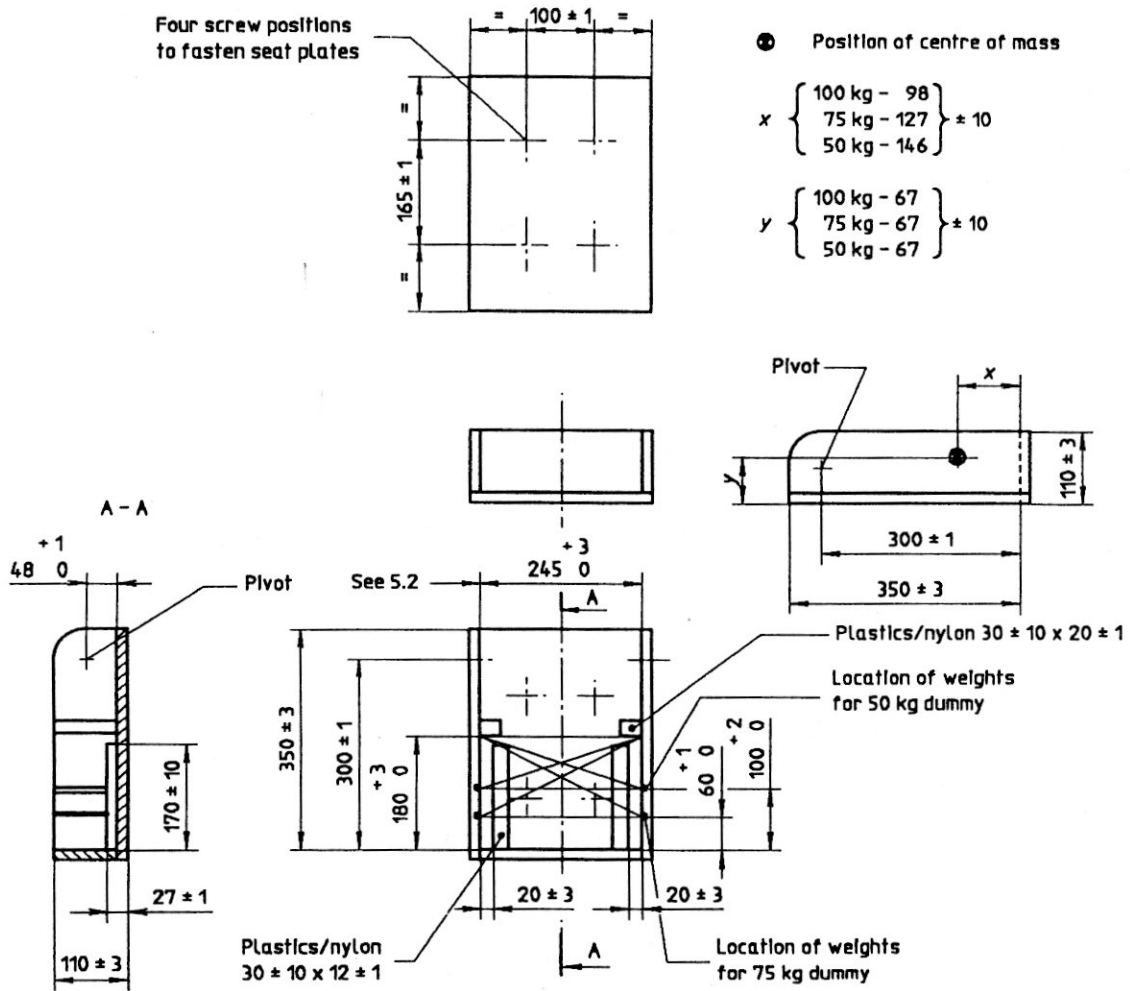

Figure 2 — Test dummy devices of 100 kg, 75 kg and 50 kg: seat construction

Dimensions in millimetres

● Position of centre of mass

$$x \begin{cases} 100 \text{ kg} - 68 \\ 75 \text{ kg} - 68 \\ 50 \text{ kg} - 68 \end{cases} \pm 10$$

$$y \begin{cases} 100 \text{ kg} - 188 \\ 75 \text{ kg} - 140 \\ 50 \text{ kg} - 84 \end{cases} \pm 10$$

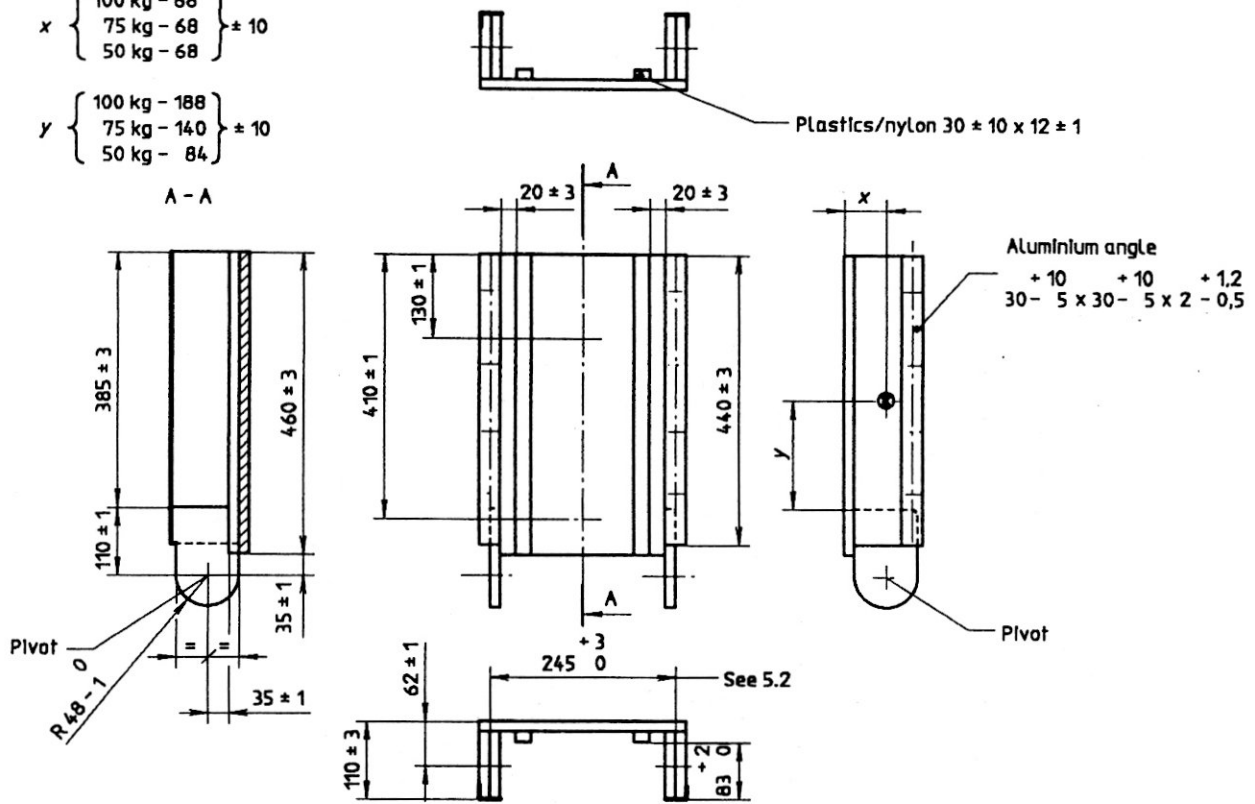

Figure 3 — Test dummy devices of 100 kg, 75 kg and 50 kg: back construction



Dimensions in millimetres

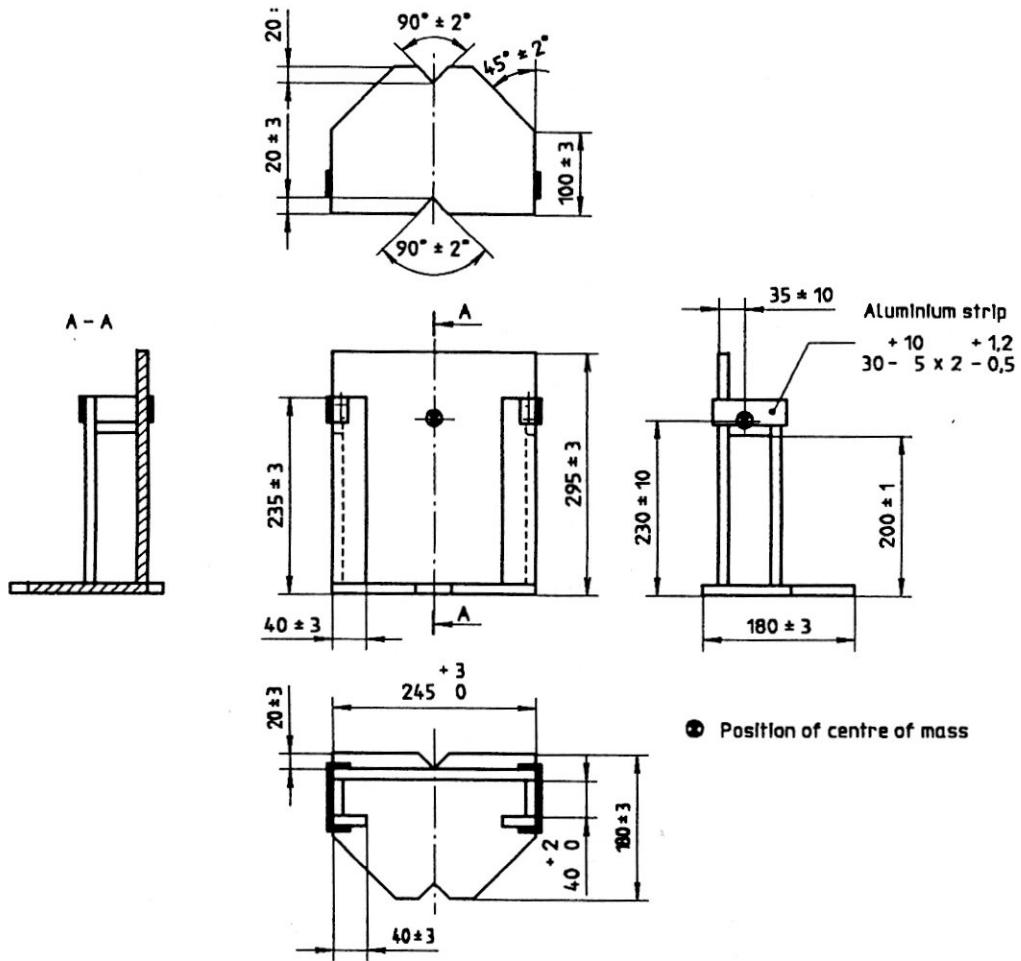

Figure 4 — Test dummy devices of 100 kg, 75 kg and 50 kg: leg construction

Dimensions in millimetres

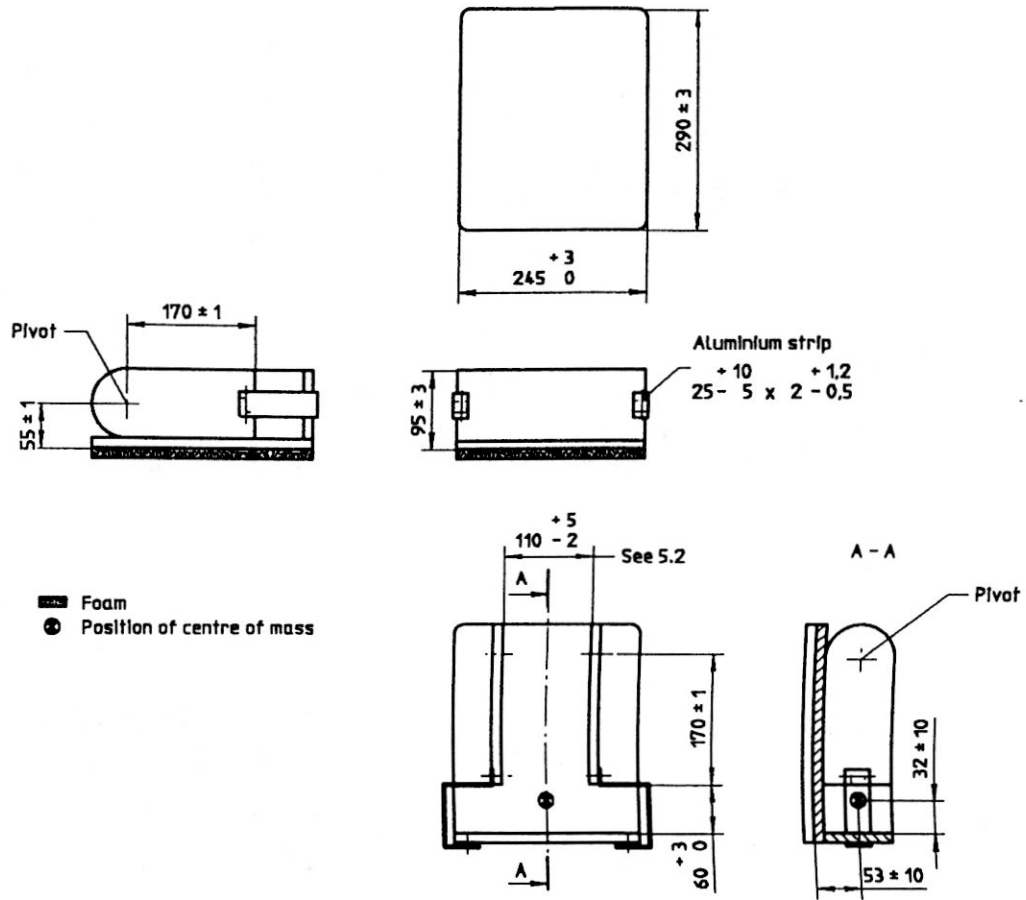

Figure 5 — Test dummy device of 25 kg: seat construction

Dimensions in millimetres

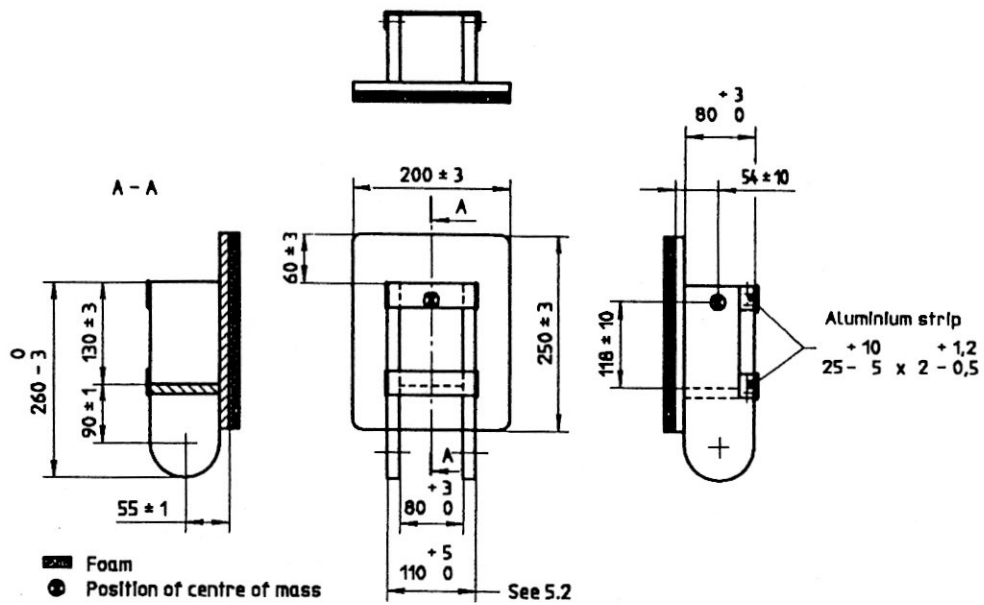

Figure 6 — Test dummy device of 25 kg: back construction

Dimensions in millimetres

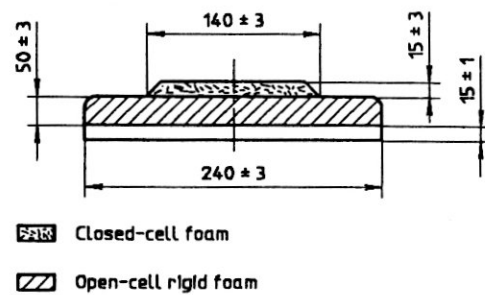

Figure 7 — Backplate for 100 kg and 75 kg dummies

Figures 7 and 8 specify the dimensions of the backplate for 100 kg, 75 kg and 50 kg dummies as indicated. In all cases, the length of the backplate shall be  $(380 \pm 3)$  mm.

Dimensions in millimetres

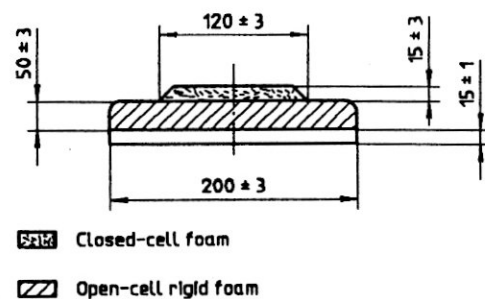

Figure 8 — Backplate for 50 kg dummy

Figures 9 to 11 specify the dimensions of the thigh plate for 100 kg, 75 kg and 50 kg dummies respectively.

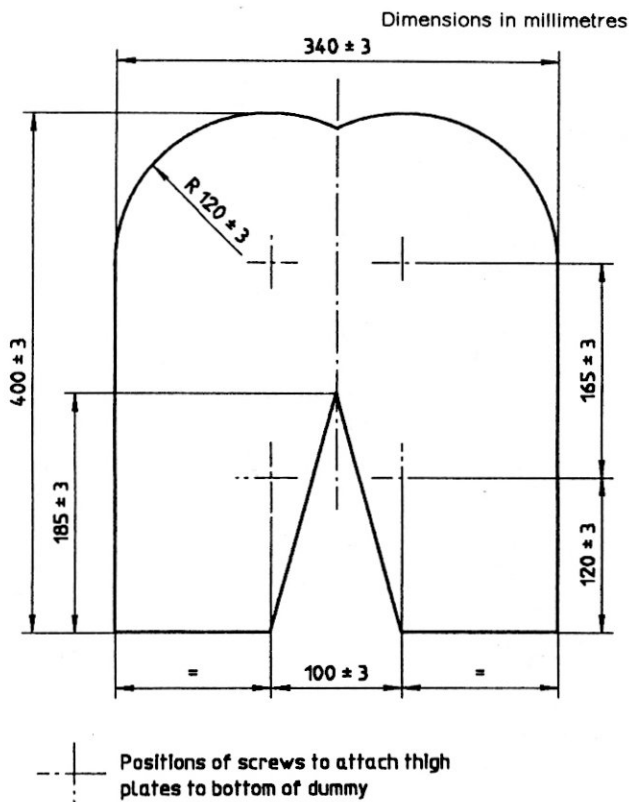

Figure 9 — Thigh plate for 100 kg dummy

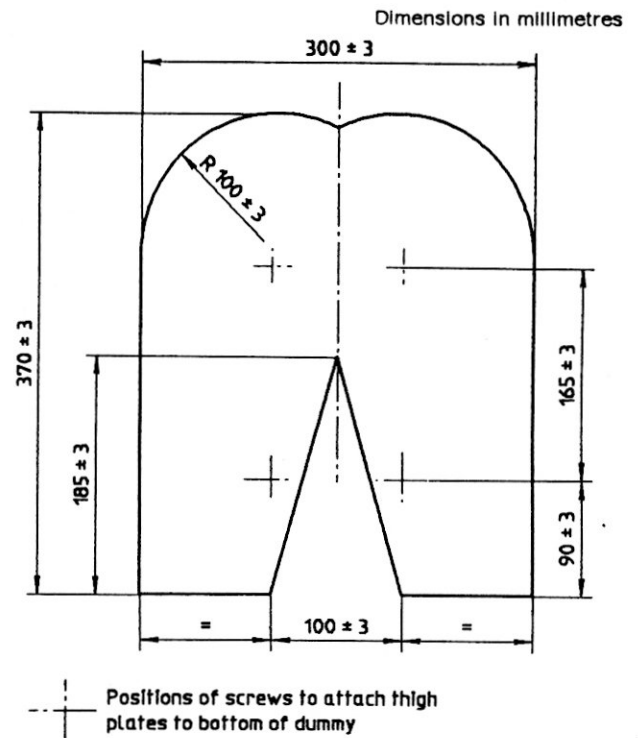

Figure 10 — Thigh plate for 75 kg dummy

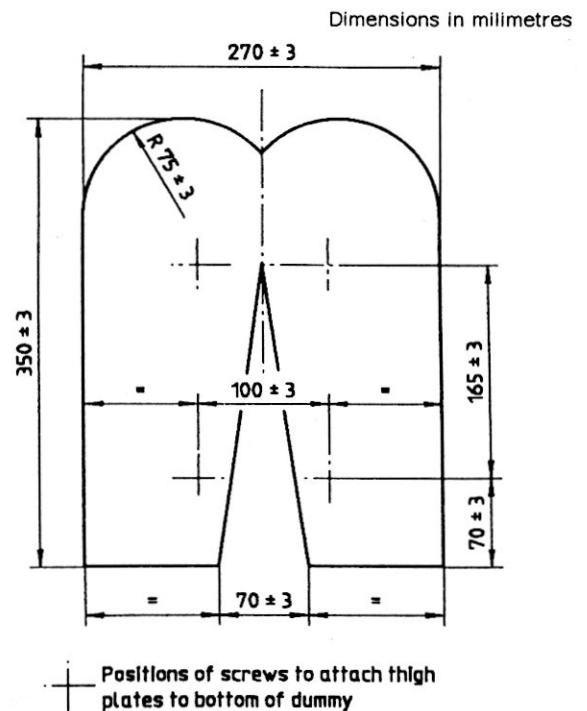
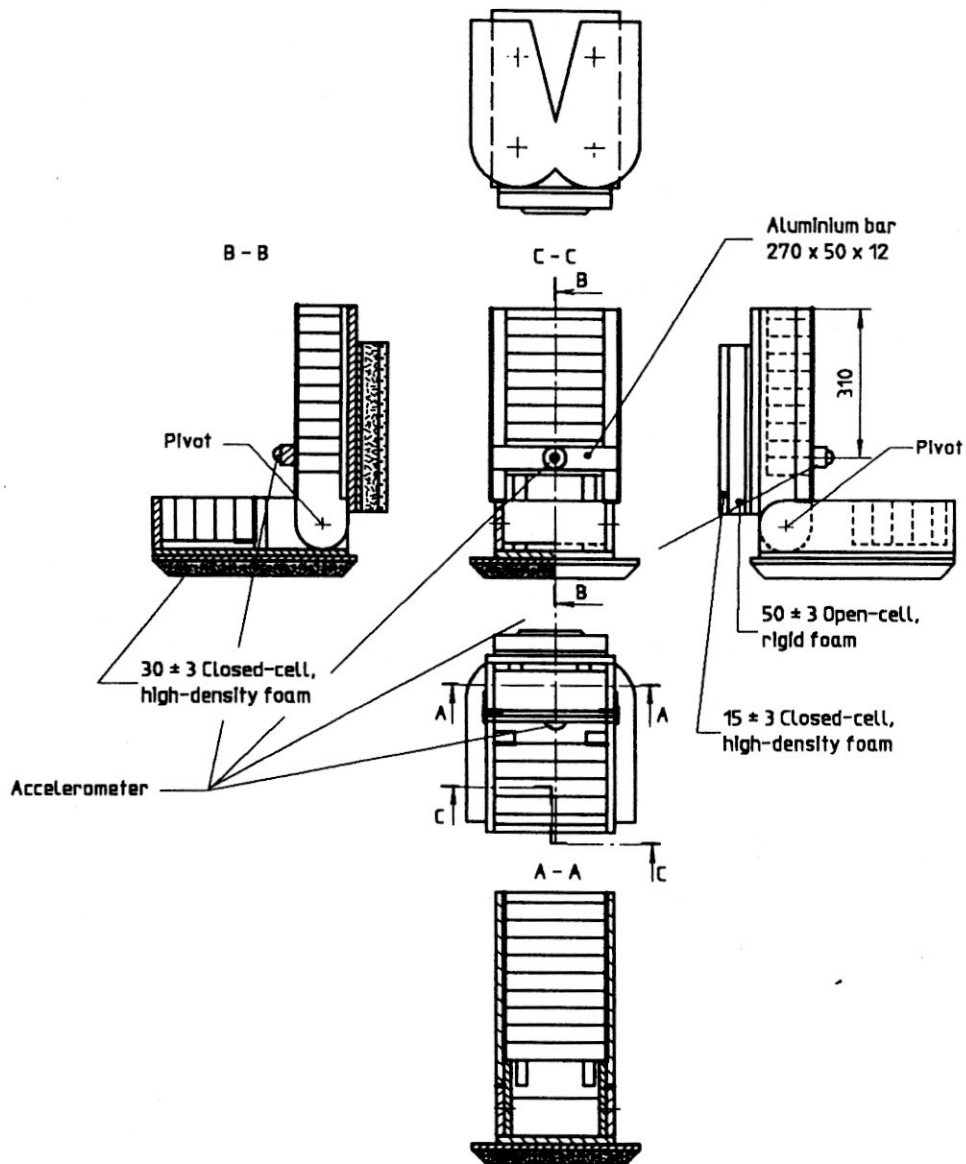

Figure 11 — Thigh plate for 50 kg dummy

**Annex A**  
(normative)

**Accelerometer mounting**

Dimensions in millimetres



**Figure A.1 — Test dummy devices of 100 kg, 75 kg and 50 kg: main construction and accelerometer mounting**

---

---

**UDC 615.478.32:620.1.05**

**Descriptors:** wheel chairs, tests, test equipment, test dummies.

Price based on 10 pages

---

---