

INTERNATIONAL STANDARD

**Household and similar electrical appliances – Safety –
Part 2-64: Particular requirements for commercial electric kitchen machines**





THIS PUBLICATION IS COPYRIGHT PROTECTED

Copyright © 2008 IEC, Geneva, Switzerland

All rights reserved. Unless otherwise specified, no part of this publication may be reproduced or utilized in any form or by any means, electronic or mechanical, including photocopying and microfilm, without permission in writing from either IEC or IEC's member National Committee in the country of the requester.

If you have any questions about IEC copyright or have an enquiry about obtaining additional rights to this publication, please contact the address below or your local IEC member National Committee for further information.

IEC Central Office
3, rue de Varembe
CH-1211 Geneva 20
Switzerland
Email: inmail@iec.ch
Web: www.iec.ch

About the IEC

The International Electrotechnical Commission (IEC) is the leading global organization that prepares and publishes International Standards for all electrical, electronic and related technologies.

About IEC publications

The technical content of IEC publications is kept under constant review by the IEC. Please make sure that you have the latest edition, a corrigenda or an amendment might have been published.

- Catalogue of IEC publications: www.iec.ch/searchpub

The IEC on-line Catalogue enables you to search by a variety of criteria (reference number, text, technical committee,...). It also gives information on projects, withdrawn and replaced publications.

- IEC Just Published: www.iec.ch/online_news/justpub

Stay up to date on all new IEC publications. Just Published details twice a month all new publications released. Available on-line and also by email.

- Electropedia: www.electropedia.org

The world's leading online dictionary of electronic and electrical terms containing more than 20 000 terms and definitions in English and French, with equivalent terms in additional languages. Also known as the International Electrotechnical Vocabulary online.

- Customer Service Centre: www.iec.ch/webstore/custserv

If you wish to give us your feedback on this publication or need further assistance, please visit the Customer Service Centre FAQ or contact us:

Email: csc@iec.ch
Tel.: +41 22 919 02 11
Fax: +41 22 919 03 00



IEC 60335-2-64

Edition 3.1 2008-03

INTERNATIONAL STANDARD

**Household and similar electrical appliances – Safety –
Part 2-64: Particular requirements for commercial electric kitchen machines**

INTERNATIONAL
ELECTROTECHNICAL
COMMISSION

PRICE CODE **CC**

ICS 97.040.10

ISBN 2-8318-9545-6

LICENSED TO MECON Limited, - RANCHI/BANGALORE
FOR INTERNAL USE AT THIS LOCATION ONLY, SUPPLIED BY BOOK SUPPLY BUREAU.

CONTENTS

FOREWORD.....	3
INTRODUCTION.....	5
1 Scope.....	6
2 Normative references	7
3 Definitions	7
4 General requirement.....	8
5 General conditions for the tests	8
6 Classification.....	9
7 Marking and instructions.....	9
8 Protection against access to live parts.....	11
9 Starting of motor-operated appliances	11
10 Power input and current	11
11 Heating	11
12 Void	12
13 Leakage current and electric strength at operating temperature.....	12
14 Transient overvoltages	12
15 Moisture resistance	12
16 Leakage current and electric strength.....	14
17 Overload protection of transformers and associated circuits	14
18 Endurance.....	14
19 Abnormal operation	14
20 Stability and mechanical hazards	14
21 Mechanical strength	20
22 Construction.....	20
23 Internal wiring.....	22
24 Components	23
25 Supply connection and external flexible cords	23
26 Terminals for external conductors.....	24
27 Provision for earthing	24
28 Screws and connections.....	24
29 Clearances, creepage distances and solid insulation	24
30 Resistance to heat and fire.....	24
31 Resistance to rusting.....	25
32 Radiation, toxicity and similar hazards.....	25
Annexes	28
Bibliography.....	28
Figure 101 – Splash apparatus	26
Figure 102 – Protection devices for slicing machines	27

INTERNATIONAL ELECTROTECHNICAL COMMISSION

**HOUSEHOLD AND SIMILAR ELECTRICAL APPLIANCES –
SAFETY –****Part 2-64: Particular requirements for commercial
electric kitchen machines**

FOREWORD

- 1) The International Electrotechnical Commission (IEC) is a worldwide organization for standardization comprising all national electrotechnical committees (IEC National Committees). The object of IEC is to promote international co-operation on all questions concerning standardization in the electrical and electronic fields. To this end and in addition to other activities, IEC publishes International Standards, Technical Specifications, Technical Reports, Publicly Available Specifications (PAS) and Guides (hereafter referred to as "IEC Publication(s)"). Their preparation is entrusted to technical committees; any IEC National Committee interested in the subject dealt with may participate in this preparatory work. International, governmental and non-governmental organizations liaising with the IEC also participate in this preparation. IEC collaborates closely with the International Organization for Standardization (ISO) in accordance with conditions determined by agreement between the two organizations.
- 2) The formal decisions or agreements of IEC on technical matters express, as nearly as possible, an international consensus of opinion on the relevant subjects since each technical committee has representation from all interested IEC National Committees.
- 3) IEC Publications have the form of recommendations for international use and are accepted by IEC National Committees in that sense. While all reasonable efforts are made to ensure that the technical content of IEC Publications is accurate, IEC cannot be held responsible for the way in which they are used or for any misinterpretation by any end user.
- 4) In order to promote international uniformity, IEC National Committees undertake to apply IEC Publications transparently to the maximum extent possible in their national and regional publications. Any divergence between any IEC Publication and the corresponding national or regional publication shall be clearly indicated in the latter.
- 5) IEC provides no marking procedure to indicate its approval and cannot be rendered responsible for any equipment declared to be in conformity with an IEC Publication.
- 6) All users should ensure that they have the latest edition of this publication.
- 7) No liability shall attach to IEC or its directors, employees, servants or agents including individual experts and members of its technical committees and IEC National Committees for any personal injury, property damage or other damage of any nature whatsoever, whether direct or indirect, or for costs (including legal fees) and expenses arising out of the publication, use of, or reliance upon, this IEC Publication or any other IEC Publications.
- 8) Attention is drawn to the Normative references cited in this publication. Use of the referenced publications is indispensable for the correct application of this publication.
- 9) Attention is drawn to the possibility that some of the elements of this IEC Publication may be the subject of patent rights. IEC shall not be held responsible for identifying any or all such patent rights.

This part of International Standard IEC 60335 has been prepared by IEC subcommittee 61E: Safety of electrical commercial catering equipment, of IEC technical committee 61: Safety of household and similar electrical appliances.

This consolidated version of IEC 60335-2-64 consists of the third edition (2002) [documents 61E/408/FDIS and 61E/420/RVD] and its amendment 1 (2007) [documents 61E/587/FDIS and 61E/592/RVD].

The technical content is therefore identical to the base edition and its amendment and has been prepared for user convenience.

It bears the edition number 3.1.

A vertical line in the margin shows where the base publication has been modified by amendment 1.

This part 2 is to be used in conjunction with the latest edition of IEC 60335-1 and its amendments. It was established on the basis of the fourth edition (2001) of that standard.

NOTE 1 When "Part 1" is mentioned in this standard, it refers to IEC 60335-1.

This part 2 supplements or modifies the corresponding clauses in IEC 60335-1, so as to convert that publication into the IEC standard: Safety requirements for commercial electric kitchen machines.

When a particular subclause of Part 1 is not mentioned in this part 2, that subclause applies as far as is reasonable. When this standard states "addition", "modification" or "replacement", the relevant text in Part 1 is to be adapted accordingly.

NOTE 2 The following numbering system is used:

- subclauses, tables and figures that are numbered starting from 101 are additional to those in Part 1;
- unless notes are in a new subclause or involve notes in Part 1, they are numbered starting from 101, including those in a replaced clause or subclause;
- additional annexes are lettered AA, BB, etc.

NOTE 3 The following print types are used:

- requirements: in roman type;
- *test specifications: in italic type;*
- notes: in small roman type.

Words in **bold** in the text are defined in Clause 3. When a definition of Part 1 concerns an adjective, the adjective and the associated noun are also in bold .

The following differences exist in the countries indicated below.

- 6.1: Class 01 appliances are allowed if their rated voltage does not exceed 150 V (Japan).
- 6.2: For appliances intended to be installed in a kitchen, an appropriate degree of protection against harmful ingress of water is required according to their height of installation (France).
- 13.2: Leakage current limits are different (Japan).
- 16.2: Leakage current limits are different (Japan).
- Clause 21: For appliances intended to be installed in a kitchen, different values of impact energy are applicable according to the height of the impact point (France).

A bilingual version of this publication may be issued at a later date.

The committee has decided that the contents of the base publication and its amendments will remain unchanged until the maintenance result date indicated on the IEC web site under "<http://webstore.iec.ch>" in the data related to the specific publication. At this date, the publication will be

- reconfirmed,
- withdrawn,
- replaced by a revised edition, or
- amended.

INTRODUCTION

It has been assumed in the drafting of this International Standard that the execution of its provisions is entrusted to appropriately qualified and experienced persons.

This standard recognizes the internationally accepted level of protection against hazards such as electrical, mechanical, thermal, fire and radiation of appliances when operated as in normal use taking into account the manufacturer's instructions. It also covers abnormal situations that can be expected in practice.

This standard takes into account the requirements of IEC 60364 as far as possible so that there is compatibility with the wiring rules when the appliance is connected to the supply mains. However, national wiring rules may differ.

If an appliance within the scope of this standard also incorporates functions that are covered by another part 2 of IEC 60335, the relevant part 2 is applied to each function separately, as far as is reasonable. If applicable, the influence of one function on the other is taken into account.

This standard is a product family standard dealing with the safety of appliances and takes precedence over horizontal and generic standards covering the same subject.

An appliance that complies with the text of this standard will not necessarily be considered to comply with the safety principles of the standard if, when examined and tested, it is found to have other features that impair the level of safety covered by these requirements.

An appliance employing materials or having forms of construction differing from those detailed in the requirements of this standard may be examined and tested according to the intent of the requirements and, if found to be substantially equivalent, may be considered to comply with the standard.

HOUSEHOLD AND SIMILAR ELECTRICAL APPLIANCES – SAFETY –

Part 2-64: Particular requirements for commercial electric kitchen machines

1 Scope

This clause of Part 1 is replaced by the following.

This standard deals with the safety of electrically operated commercial **kitchen machines** not intended for household use, their **rated voltage** being not more than 250 V for single phase appliances connected between one phase and neutral, and 480 V for other appliances.

NOTE 101 These appliances are used for example in restaurants, canteens, hospitals and commercial enterprises such as bakeries, butchers, etc.

NOTE 102 Examples of kitchen machines are

- mixers;
- liquid or food blenders;
- kneaders;
- beaters;
- shredders;
- graters;
- mincers;
- slicers;
- peelers;
- tin openers;
- coffee grinders;
- machines used for washing and/or drying food;
- portioning machines;
- pastry rollers;
- noodle strip cutters;
- food processors;
- beam mixers.

This standard also applies to appliances which, in order to facilitate transport, are supplied in several parts (sub-assemblies) which, when assembled at the place of installation, form a constructional unit without the use of any additional parts.

The electrical part of appliances making use of other forms of energy is also within the scope of this standard.

As far as is practicable, this standard deals with the common hazards presented by these types of appliances.

NOTE 103 Attention is drawn to the fact that

- for appliances intended to be used in vehicles or on board ships or aircraft, additional requirements may be necessary;
- in many countries, additional requirements are specified by the national health authorities, the national authorities responsible for the protection of labour, the national water supply authorities and similar authorities.

NOTE 104 This standard does not apply to

- appliances designed exclusively for industrial purposes;
- appliances intended to be used in locations where special conditions prevail, such as the presence of a corrosive or explosive atmosphere (dust, vapour or gas);
- continuous process appliances for the mass production of food;
- independent conveying equipment, such as food distribution belts.

2 Normative references

This clause of Part 1 is applicable.

3 Definitions

This clause of Part 1 is applicable except as follows.

3.1.4 Addition:

NOTE 101 The **rated power input** is the sum of the power inputs of all the individual elements in the appliance that can be on at one time; where there are several such combinations possible, that giving the highest power input is used in determining the **rated power input**.

3.1.9 Replacement:

normal operation

operation of the appliance under the following conditions

The appliance is operated without load at **rated voltage** and with controls intended to be adjusted by the user set at maximum until steady conditions are established. The appliance is then loaded in appropriate steps, the supply voltage being maintained at its original value. For each step, steady conditions have to be established before increasing the load. This operation is repeated until just before an overload release operates, or until the steady condition with the highest temperature has been attained.

NOTE 101 The load may be achieved by using an electrical or mechanical brake.

Where it is not possible or is impractical to apply effectively an electrical or mechanical brake, the load is 115 % of the input measured when the appliance is operated without load at **rated voltage** and normal operating temperature, and with controls intended to be adjusted by the user set at maximum.

NOTE 102 Examples of such appliances are

- liquid blenders;
- slicers;
- peelers;
- coffee grinders;
- machines used for washing and/or drying food;
- portioning machines.

3.101

indicated level

mark on the appliance to indicate the maximum liquid level for correct operation

3.102

installation wall

special fixed construction containing supply facilities for appliances installed in conjunction with it

3.103**guard plate**

plate similar to a slice thickness plate, fitted to machines with automatic product feeding

3.104**product holder**

support for the product to be sliced. The **product holder** can be equipped with a **pusher** or a **feed carriage** and/or a clamping device

3.105**sliding feed table**

device that supports the **product holder** and allows it to move forwards and backwards

3.106**feed carriage**

device on which the product is placed and that slides on top of the **product holder** in order to move the product towards the blade

3.107**pusher**

device used to move the product along the **product holder** against the thickness plate

3.108**last slice device**

plate with which the last portion of the product is fed to the cutting blade

NOTE The plate can be fitted on the **pusher**, clamping device or **feed carriage**.

4 General requirement

This clause of Part 1 is applicable.

5 General conditions for the tests

This clause of Part 1 is applicable except as follows.

5.6 Addition:

Speed controls are set in accordance with the instructions for use.

5.10 Addition:

*Appliances intended for installation in a bank of other appliances and appliances intended to be fixed to an **installation wall** are enclosed to obtain protection against electric shock and harmful ingress of water equivalent to that when installed in accordance with the instructions provided with the appliance.*

NOTE 101 Appropriate enclosures or additional appliances may be needed for test purposes.

5.101 Appliances are tested as *motor-operated appliances*, even if they incorporate a *heating element*.

5.102 Appliances, when assembled in combination with or incorporating other appliances, are tested in accordance with the requirements of this standard. The other appliances are operated simultaneously in accordance with the requirements of the relevant standards.

6 Classification

This clause of Part 1 is applicable except as follows.

6.1 Replacement:

Hand-held appliances shall be **class II** or **class III** with respect to protection against electric shock. Other appliances shall be **class I**, **class II** or **class III** with respect to protection against electric shock.

Compliance is checked by inspection and by the relevant tests.

6.2 Modification:

Instead of the requirement, the following applies.

Appliances shall be at least IPX1 with respect to protection against harmful ingress of water.

7 Marking and instructions

This clause of Part 1 is applicable except as follows.

7.1 Addition:

If the appliance is marked with rated "on" and "off" periods, the marking shall correspond to normal use. The marking of the "on" period shall precede the marking of the "off" period, both markings being separated by an oblique stroke.

In addition, appliances shall be marked with the water pressure or range of pressures, in kilopascals (kPa), for appliances intended to be connected to a water supply, unless this is indicated in the instructions for use.

If the reversal of a motor could cause a hazard, then the direction of rotation should be clearly and visibly indicated on the motor, if the direction of rotation depends on the way the motor is connected to the supply.

7.6 Addition:



[symbol 5021 of IEC 60417-1]

equipotentiality

7.12 Addition:

The instructions for use shall include the operating times and speed settings for accessories, unless this information is marked on the appliance.

The instructions for use shall warn against misuse, and shall state that care is needed when handling cutting blades during cleaning.

The instructions for use shall contain instructions for cleaning of all surfaces coming into contact with food during normal use.

Operating instructions included in the operating manual shall clearly indicate how to use particular or special safeguards provided with the appliance, and shall draw the attention of the user to any remaining hazards and give information about preventative measures to be taken by the user for the safe use of the appliance.

NOTE 101 Examples of appliances with remaining hazards are those that are not subjected to the test with the test probe in 20.2.

Information shall also be given about the correct assembly and safe use of accessories provided with the appliance and, if relevant, about possible hazards that might arise when using accessories other than those provided with the appliance. The instructions for use shall warn the user to use a suitable bowl with attachable accessories such as egg beaters and sieving machines, and shall indicate that the accessory must not project from the upper part of the bowl.

The instructions for use for hand-held blenders and whisks shall contain a warning against the use of these appliances when not in contact with the product.

The instructions for use for food processors shall state that care is needed when handling cutting blades, especially when removing the blades from the bowl, emptying the bowl and during cleaning.

The instructions for use for mincers, where the required safety at the discharge outlets depends entirely on perforated discs provided with the appliance, shall contain a warning against use of perforated discs with oval shaped holes or holes of a greater diameter.

The instructions for use for slicers shall give details for assembly and removal of blades and shall require that the slice thickness plate or **guard plate** shall be set to the zero position during the cleaning of the blade while still installed in the appliance.

The instructions for use shall identify separate sharpening devices suitable for use with the appliance, and shall state that only those devices shall be used.

NOTE 102 A code or similar means may be used for identification purposes.

If symbol 5021 is marked on the appliance its meaning shall be explained.

7.12.1 Replacement:

The appliance shall be accompanied by instructions detailing any special precautions necessary for installation. For appliances intended for installation in a bank of other appliances, and appliances intended to be fixed to an **installation wall**, details of how to ensure appropriate protection against electric shock and harmful ingress of water shall be supplied. If the controls of more than one appliance are combined in a separate enclosure, detailed installation instructions shall be supplied. Instructions for **user maintenance**, for example cleaning, shall also be given. They shall include a statement that the appliance is not to be cleaned with a water jet.

For appliances that are permanently connected to fixed wiring, and for which leakage currents may exceed 10 mA, particularly if disconnected or not used for long periods, or during initial installation, the instructions shall give recommendations regarding the rating of **protective devices**, such as earth leakage relays, to be installed.

Compliance is checked by inspection.

7.101 Equipotential bonding terminals shall be marked with symbol 5021 of IEC 60417-1.

These markings shall not be placed on screws, removable washers or other parts that can be removed when conductors are being connected.

Compliance is checked by inspection.

7.102 Appliances intended to be filled by hand or by a manually operated tap shall be marked with an **indicated level**.

Compliance is checked by inspection.

8 Protection against access to live parts

This clause of Part 1 is applicable.

9 Starting of motor-operated appliances

This clause of Part 1 is applicable except as follows.

9.101 Motors incorporated in the appliance shall start within three seconds, if delayed starting could result in a hazard.

Fan motors, providing a cooling effect in order to comply with the requirements of Clause 11, shall start under all voltage conditions that may occur in use.

*Compliance is checked by starting the motor three times at a voltage equal to 0,85 times **rated voltage**, the motor being at room temperature at the beginning of the test.*

*The motor is started each time under the conditions occurring at the beginning of **normal operation** or, for automatic appliances, at the beginning of the normal cycle of operation, the motor being allowed to come to rest between successive starts. For appliances provided with motors having other than centrifugal starting switches, this test is repeated at a voltage equal to 1,06 times **rated voltage**.*

*In all cases, the motor shall start and it shall function in such a way that safety is not affected, and the overload **protection devices** of the motor shall not operate.*

NOTE The supply source is such that, during the test, the drop in voltage does not exceed 1 %.

10 Power input and current

This clause of Part 1 is applicable except as follows.

10.1 Addition:

NOTE 101 For appliances having more than one heating unit, the total power input may be determined by measuring the power input of each heating unit separately (see also 3.1.4).

11 Heating

This clause of Part 1 is applicable except as follows.

11.2 Addition:

Appliances intended to be fixed to the floor, and appliances with a mass greater than 40 kg and not provided with rollers, castors or similar means, are installed in accordance with the manufacturer's instructions. If no instructions are given, these appliances are considered as appliances normally placed on the floor.

11.7 Replacement:

Appliances are operated until steady conditions are established.

NOTE 101 The duration of the test may consist of more than one cycle of operation. If the appliance is marked with rated "on" and "off" periods, it is taken into account.

12 Void

13 Leakage current and electric strength at operating temperature

This clause of Part 1 is applicable except as follows.

13.2 Modification:

Instead of the permissible leakage current for **stationary class I appliances**, the following applies:

- *for appliances without heating elements* 3,5 mA
- *for appliances with heating elements, cord and plug connected* 1 mA per kW **rated power input** of the appliance with a maximum of 10 mA
- *for other appliances with heating elements* 1 mA per kW **rated power input** of the appliance with no maximum

14 Transient overvoltages

This clause of Part 1 is applicable.

15 Moisture resistance

This clause of Part 1 is applicable except as follows.

15.1.1 Addition:

In addition, IPX1, IPX2, IPX3 and IPX4 appliances are subjected for 5 min to the following splash test.

The apparatus shown in Figure 101 is used. During the test, the water pressure is so regulated that the water splashes up 150 mm above the bottom of the bowl. The bowl is placed on the floor for appliances normally used on the floor. For all other appliances, on a horizontal support 50 mm below the lowest edge of the appliance, the bowl is so moved around as to splash the appliance from all directions. Care is taken that the appliance is not hit by the direct jet.

15.1.2 Modification:

Appliances normally used on a table are placed on a support having dimensions that are 15 cm ± 5 cm in excess of those of the orthogonal projection of the appliance on the support.

15.2 Replacement:

Appliances shall be constructed so that spillage of liquid in normal use does not affect their electrical insulation.

Compliance is checked by the following test.

*Appliances with **type X attachment**, except those having a specially prepared cord, are fitted with the lightest permissible type of flexible cable or cord of the smallest cross-sectional area specified in 26.6, and other appliances are tested as delivered.*

***Detachable parts** are removed or in position, whichever is the most unfavourable.*

Water outlets, if any, are blocked.

The water containers of appliances intended to be filled with water by hand are completely filled with water containing approximately 1 % NaCl and a further quantity, equal to 15 % of the capacity of the container but not more than 10 l, is poured in steadily over a period of 1 min.

Appliances intended to be filled by a manually operated tap or automatically are connected to a water supply having the maximum supply pressure indicated by the manufacturer. The means for controlling the incoming water is held fully open, and the filling continued for 1 min after the first evidence of overflow, or until a further protective system operates to stop the inflow.

*With the container filled with water, the appliance is then operated at **rated voltage** for 15 s. Lids or covers are in position or removed, whichever is the most unfavourable.*

*The appliance shall then withstand the electric strength test of 16.3, and inspection shall show that there is no trace of water on the insulation that could result in a reduction of **clearances and creepage distances** below the values specified in Clause 29.*

15.3 Addition:

NOTE 101 If it is not possible to place the whole appliance in the humidity cabinet, parts containing electrical components are tested separately, taking into account the conditions that occur in the appliance.

15.101 Appliances that are provided with a tap intended for filling or cleaning shall be constructed so that the water from the tap cannot come into contact with **live parts**.

Compliance is checked by the following test.

The tap is fully opened for 1 min with the appliance connected to a water supply having the maximum water pressure indicated by the manufacturer. Tiltable and movable parts, including lids, are tilted or placed in the most unfavourable position. Swivelling outlets of water taps are so positioned as to direct water on to those parts that will give the most unfavourable result. Immediately following this treatment, the appliance shall withstand an electric strength test as specified in 16.3.

16 Leakage current and electric strength

This clause of Part 1 is applicable except as follows.

16.2 Modification:

Instead of the permissible leakage current for **stationary class I appliances**, the following applies:

- *for appliances without heating elements* 3,5 mA
- *for appliances with heating elements, cord and plug connected* 1 mA per kW **rated power input** of the appliance with a maximum of 10 mA
- *for other appliances with heating elements* 1 mA per kW **rated power input** of the appliance with no maximum

17 Overload protection of transformers and associated circuits

This clause of Part 1 is applicable.

18 Endurance

This clause of Part 1 is applicable.

19 Abnormal operation

This clause of Part 1 is applicable except as follows.

19.1 Addition:

A control or switching device that is intended for different settings corresponding to different functions of the same part of the appliance that are covered by different standards is, in addition, set in the most severe setting irrespective of the instructions for use.

19.2 Addition:

Appliances are operated with empty heated containers.

19.4 Addition:

NOTE 101 The main contacts of the contactor intended for switching on and off the heating element(s) in normal use are locked in the "on" position. However, if two contactors operate independently of each other, or if one contactor operates two independent sets of main contacts, these contacts are locked in the "on" position in turn.

20 Stability and mechanical hazards

This clause of Part 1 is applicable except as follows.

20.2 Addition:

Add the following after the second paragraph of the requirement.

Covers and the like, protecting danger zones within the operating range of the appliance, shall be **detachable** only when the risk is excluded by other means.

NOTE 101 Parts that do not move more than 4 mm away from each other are not regarded as dangerous crushing (squashing) and shearing zones.

NOTE 102 Drawing-in zones can only occur during operations where uncovered movable parts move past stationary and/or moving parts.

Add the following after the first paragraph of the test specification.

However, for feed apertures and discharge apertures, unless otherwise specified, the test is carried out with test probe B of IEC 61032, but having a non-circular stop face with a diameter of 56 mm instead of 50 mm and with the distance between the tip of the test probe and the stop face being 120 mm. The 75 mm diameter guard is removed. The test probe is not inserted into the aperture for a linear distance of more than 850 mm, measured from the tip of the probe, if the aperture has a largest dimension of less than 150 mm.

NOTE 103 Moving parts that can be touched by the test probe through discharge apertures are not considered to be dangerous if they have a smooth surface or are constructed so that the risk of entrapment or injury is negligible.

For some appliances complete protection is impracticable and the test with the test probe is therefore not carried out. Examples of such appliances are

- *hand-held appliances;*
- *slicers;*
- *tin openers;*
- *pastry rollers;*
- *noodle strip cutters;*
- *sieving machines;*
- *peelers (discharge apertures only);*
- *bone saws (circular or band type);*
- *citrus juice squeezers;*
- *egg beaters designated as attachable accessories;*
- *knife sharpeners.*

Modification:

Delete Note 1.

20.101 Locking devices, the release of which could create a hazard, shall be constructed so that they cannot be actuated accidentally.

Compliance is checked by a test with test probe B of IEC 61032. It shall not be possible to release the locking device with the probe.

20.102 Fixing devices of functional parts, such as attachable accessories, shall not work loose unintentionally. Driven shafts that might constitute a hazard – except within the operating range – shall be adequately protected against accidental contact.

Compliance is checked by inspection and by a test using test probe B of IEC 61032.

20.103 Appliances, or parts of appliances, that are designed to tilt in normal use shall not give rise to any hazard. Accidental tilting from any position, even in the case of supply interruption, shall be prevented and there shall be no crushing zone between the tilting part and the appliance except at the bumper point when the part is fully tilted.

Compliance is checked by inspection, by manual test and by switching off the supply to the appliance at any time during the tilting operation.

NOTE The requirement may be met by, for example, one of the following means:

- providing switches that have to be kept switched on by hand;
- limiting the rate of motion (peripheral speed) to 50 mm/s;
- protecting danger zones by means of appropriate guards;
- maintaining moving parts securely in position - even in the case of a fault.

If the appliance or part is tilted manually, it shall not be possible to adversely influence the tilting action other than by the intended means.

Compliance is checked by inspection and by applying a force of 340 N at any point on the tiltable part.

20.104 Moving rollers shall be adequately protected at their drawing-in zones, that is by means of a safety screen or non-driven protective rollers and/or bars, unless they are spring-loaded with a maximum pressure of 50 kPa, with an emergency switching device, and that the gap between the pair of rollers is at least 60 mm.

Compliance is checked by inspection, measurement and manual test.

20.105 Switches shall be positioned within easy reach of the operator's hand. Start switches shall be secured against accidental actuation, if their actuation could result in a hazard.

Compliance is checked by inspection and by applying a cylindrical rod having a diameter of 40 mm and a hemispherical end to the switch. The appliance shall not operate.

20.106 Devices, such as sliding feed tables, **product holders**, stop plates, etc., shall ensure safe working within the operating range.

Compliance is checked by inspection, measurement and manual test.

NOTE This requirement may be met by using for example

- a **product holder** that protects the whole of the operating range and that is so undetachably fixed to the sliding feed table, that it automatically drops when the feed table is folded back, and that cannot be moved more than 80 mm away from the knife;
- a **product holder** that is automatically moved up to the knife, and that is provided with a guard at the stop-plate and a finger-guard at the sliding feed table;
- in the case of gravity-driven systems, a back wall on the feed table, with a height equal to the diameter of the knife.

20.107 Accidental contact with devices of driven shafts that engage on attachable accessories shall be prevented, unless their movement is possible only after attachable accessories have been engaged.

Compliance is checked by inspection and by manual test.

NOTE The requirement is considered to be met, for example, if the devices are recessed in their housing or are constructed so that contact would not result in a hazard.

20.108 Circular saws shall be provided with covers where the operating range is opened only by the workpiece itself, as far as is necessary, and where the operating range is automatically covered again, when the operating cycle comes to an end.

Compliance is checked by inspection and by manual test.

20.109 Blades of hand-held blenders shall be completely screened from above and shall not be able to touch a flat surface when rotating.

Compliance is checked by inspection and by applying a cylindrical rod from any position between the vertical and an angle of 45° to the upper side of the blending blade. The rod has a diameter of 8,0 mm ± 0,1 mm and unlimited length.

It shall not be possible to touch the blades with the end of the test rod.

20.110 Appliances for washing and drying foodstuffs, that have a rotating drum with a kinetic energy of more than 200 J, shall be provided with a cover interlocked so that the appliance will not start when the cover is open. If the cover is opened while the appliance is operating, the drum shall stop within 2 s.

*Compliance is checked by inspection, measurement and manual test. The appliance is supplied at **rated voltage** and without a load.*

20.111 Dangerous moving parts that are accessible after covers or lids are opened shall stop within 2 s after the cover or lid has been opened or removed. When closed again, the automatic restarting of the appliance shall be possible only if this does not result in a hazard.

Compliance is checked by operating the appliance without load and at the highest speed.

20.112 Appliances shall be constructed so that the omission or replacement in an incorrect position of **detachable parts** will not result in a hazard.

Compliance is checked by inspection and manual test.

20.113 Hand-held whisks shall be provided with a guard to avoid accidental slipping of the hand into the tool. Its dimensions shall be at least 30 mm greater than the dimensions of the handgrip zone, and it shall be located between the handgrip zone and the tool.

Compliance is checked by inspection, measurement and manual test.

20.114 Beam mixers shall automatically switch off when the head is raised to a height of 300 mm above the supporting surface, unless the appliance incorporates a switch that has to be kept switched on by hand.

Compliance is checked by inspection and by measurement.

20.115 Unloading of the product from peelers shall not cause a hazard.

Compliance is checked by inspection and manual test.

NOTE The requirement may be met by, for example

- suitable guards preventing contact, except by a deliberate action, with rotating plates involving hazards of trap or injury;
- for rotating plates provided with cutting blades, the need to use one hand to keep the discharge door or lid open and the provision of a switch that has to be kept switched on by hand to allow for unloading of the product.

20.116 Slicing machines shall be stable when in use.

NOTE 1 This requirement does not apply to **fixed appliances**.

Compliance is checked by the following test.

The slicing machine is placed in accordance with the instructions for use on a plain glass plate that is placed on a horizontal surface.

NOTE 2 The glass surface is prevented from sliding by a stop.

A force of 50 N is applied horizontally to the appliance in the most unfavourable direction at a point 10 mm below the upper surface of the base carrying the sliding feed table.

The appliance shall not move on the glass plate.

NOTE 3 Suction cups are suitable means, if any, to hold the appliance in place and allow it to be released after use.

20.117 Blades of slicing machines shall be adequately protected.

The requirements may be met by the following provisions.

Compliance is checked by inspection, measurement and manual test.

NOTE Alternative provisions giving an equivalent or greater degree of protection may also meet the requirements.

20.117.1 A guard surrounding the circular blade shall be provided, its open sector being no larger than required for using the appliance. The angle Θ (Theta) of the upper part of the open sector shown in Figure 102 shall not exceed 60°.

The radial distance *a* between the outer circumference of the blade and the blade guard shall not exceed 6 mm, and the guard shall project at least 1 mm beyond the plane of the blade (distance *b*).

20.117.2 When the slice thickness plate is set to the zero position, the distance *c* between the outer circumference of the blade and the slice thickness plate shall not exceed 6 mm and the thickness plate shall project at least 1 mm beyond the plane of the blade. At the upper and lower points of the open sector, the distance *e* between the slice thickness plate and any other protecting part shall not exceed 5 mm.

NOTE 1 If the distance *e* is shielded, the limit does not apply.

Additional guarding shall be provided if slices thicker than 15 mm can be cut.

NOTE 2 An extension of the upper end of the slice thickness plate or an extension of the blade guard are examples of additional guarding.

Appliances shall not be capable of cutting slices thicker than 40 mm.

If the appliance is equipped with a slice support, this shall project at least 1 mm beyond the plane of the blade.

20.117.3 Slicing machines shall incorporate a **sliding feed table**, a thumb guard and a **product holder**. The thumb guard shall screen the full height of the open sector and shall be constructed so that the other fingers remain at least 30 mm away from the blade (distance *f*). The distance *d* between the plane of the thumb guard and the blade shall not exceed 6 mm. At the end of the forward movement of the **sliding feed table**, the thumb guard shall project at least 10 mm beyond the outer circumference of the blade.

NOTE For slicing machines with automatic feeding, the requirement applies to the guard plate.

It is not required to provide a thumb guard if the **product holder** incorporates means for clamping the food. In this case

- the handle of the **sliding feed table** shall be protected by a plate having dimensions at least 30 mm in excess of those of the handle. The handle shall be at least 80 mm from the blade;
- the handle of the clamping device shall be protected either by a guard or a **last slice device**, having dimensions of at least 50 mm in excess of those of the handle;
- it shall not be possible to remove the **feed carriage** from the **product holder**.

It shall only be possible to lift or remove the **product holder** when the plate that sets the thickness of the slices is in the zero position. It shall not be possible to change this setting when the **product holder** has been lifted or removed.

20.117.4 Sharpening devices integral with the appliance shall be constructed so that during normal use of the appliance, a continuous cover over the blade is ensured in the same manner as the blade guard.

In the sharpening position, that part of the blade that is exposed shall not project more than 6 mm from each side of the abrasive wheels used for grinding.

Separate sharpening devices shall, when fixed to the appliance, have a suitable guard to cover the exposed parts of the blade. Any gap between the abrasive wheels used for grinding and the guard shall not exceed 6 mm.

The construction of both integral and separate sharpening devices shall not allow the blade to be sharpened when the gap between the blade and the blade guard exceeds 6 mm.

20.117.5 Pushers of slicing machines shall cover the exposed cutting sector of the blade or have a handle provided with a protective plate that is always at least 150 mm from the blade.

It shall only be possible for the **pusher** to remain in the raised position when the distance between the **pusher** and the blade is at least 60 mm. It shall not be possible to remove the arm of the **pusher** or to swing it outside of the **sliding feed table**.

20.117.6 Manual **feed carriages** shall be provided with a handle meeting the same dimensional requirements of 20.117.3 or 20.117.5 as appropriate. If they can be raised for cleaning, they shall fall back to the normal working position when released.

20.117.7 Slicing machines with automatic product feeding and not provided with a plate that sets the thickness of the slices shall incorporate a **guard plate** that covers the exposed cutting sector of the blade and extends beyond the front of the stroke of the **product holder** by at least 10 mm. It shall not be possible to move the **guard plate** away from the blade by more than the maximum slice thickness plus 3 mm. The provisions applicable to slice thickness plates apply to **guard plates**.

20.117.8 Slicing machines with a power-driven **sliding feed table** shall be constructed so that gaps between moving parts and other parts do not give rise to trapping or crushing hazards.

NOTE This requirement is considered to be met if, for example, the gap is less than 6 mm or more than 25 mm.

20.118 The discharge apertures of mincers shall be adequately protected.

*Compliance is checked by inspection and by a test with the test finger for feed and discharge apertures described in 20.2. The appliance is tested with the protective perforated disc in place as in normal use, even if the disc is **detachable**. The test finger shall not touch dangerous parts.*

20.119 Knife sharpeners shall not rotate at a speed exceeding 200 rev/min.

Compliance is checked by measurement.

20.120 Hazardous moving parts of bone saws of the band type shall be adequately protected. When these parts are accessible after lids, doors or guards are opened, the requirements of 20.111 apply.

Appliances with a cutting height not exceeding 250 mm shall be provided with a fixed table, a slice thickness plate of a height of at least 100 mm and a hinged **pusher** that protects the whole of the operating range and that automatically drops to its protective position when released. It shall be possible to change the blade without removing the **pusher**.

Appliances with a cutting height exceeding 250 mm with a fixed table shall be provided with a slice thickness plate of a height of at least 100 mm and a **last slice device** with a minimum height of 150 mm. The appliance shall incorporate an adjustable blade guard protecting the part of the blade not used for cutting. It shall be possible to lower the blade guard to at least 105 mm from the table. It shall also be possible to change the blade without removing the blade guard.

If the appliance is provided with a sliding table, its rear edge shall have a height of at least 60 mm and shall incorporate a finger guard at least 100 mm high and 50 mm wide. At the end of the forward movement of the sliding table the finger guard shall project at least 10 mm beyond the blade. The other requirements for appliances with a cutting height not exceeding 250 mm are also applicable.

Compliance is checked by inspection, measurement and manual test.

NOTE The requirements may be met by alternative means that provide at least the same degree of protection.

21 Mechanical strength

This clause of Part 1 is applicable except as follows.

Addition:

The test is also made on detachable parts that are necessary for protection against mechanical hazards.

21.101 Detachable and non-detachable parts that are necessary for protection against mechanical hazards shall have adequate resistance to distortion.

Compliance is checked by applying a force of 50 N to the parts in the most unfavourable direction. The test is repeated three times. After the test, protective guards and the like shall show no damage within the meaning of this standard; in particular, guards and the like protecting blades and cutting knives shall not be distorted or deflected in such a way as to impair compliance with 20.2 and other relevant additional subclauses.

22 Construction

This clause of Part 1 is applicable except as follows.

22.101 For 3-phase appliances, **thermal cut-out** protecting circuits with heating elements, and those for motors of which the unexpected starting may cause a hazard, shall be of the non-self-resetting, trip-free type and shall provide **all-pole disconnection** from related supply circuits.

For single-phase appliances and for single-phase heating elements and/or motors connected between one phase and neutral or between phase and phase, thermal cut-out protecting circuits with heating elements, and those for motors of which the unexpected starting may cause a hazard, shall be of the non-self-resetting trip-free type and shall provide at least one-pole disconnection.

If the **non-self-resetting thermal cut-out** is only accessible after removing parts with the aid of a **tool**, the trip-free type is not required.

NOTE 1 **Thermal cut-outs** of the trip-free type have an automatic action, with a reset actuating member, so constructed that the automatic action is independent of manipulation or position of the reset mechanism.

Thermal cut-outs of the bulb and capillary type that operate during the tests of Clause 19 shall be such that rupture of the capillary tube shall not impair compliance with the requirements of 19.13.

Compliance is checked by inspection and by manual test, and by rupturing the capillary tube.

NOTE 2 Care must be taken to ensure that the rupture does not seal the capillary tube.

22.102 Lights, switches or push-buttons shall only be coloured red for the indication of danger, alarm or similar situations.

Compliance is checked by inspection.

22.103 Drain cocks and other emptying devices for hot liquids shall be constructed so that they cannot be opened inadvertently. Moreover, it shall not be possible to withdraw drain plugs inadvertently.

Compliance is checked by inspection and by manual test.

NOTE For example, this requirement is met when the valve handle is such that, when released, it returns automatically to the closed position, or is of the wheel type or is placed in a recess.

22.104 Means provided to allow drainage of liquid from appliances shall discharge the liquid in such a manner that electrical insulation is not affected.

Compliance is checked by inspection and by manual test.

22.105 Accessories requiring an electrical supply shall have that supply derived from the appliance.

Compliance is checked by inspection.

22.106 Appliances shall be constructed so that lubricants, abrasives and the like cannot come into contact with the ingredients.

Compliance is checked by inspection.

22.107 Portable appliances shall not have openings on the underside that would allow small items to penetrate and touch **live parts**.

*Compliance is checked by inspection and by measuring the distance between the supporting surface and **live parts** through openings. This distance shall be at least 6 mm. However, if the appliance is fitted with legs, this distance is increased to 10 mm if the appliance is intended to stand on the table and to 20 mm if it is intended to stand on the floor.*

22.108 The level to which manually filled appliances have to be filled shall be so located as to be readily visible when filling.

Compliance is checked by inspection.

22.109 Appliances shall be constructed so that food or liquids are prevented from penetrating places that could cause electrical or mechanical faults.

Compliance is checked by inspection.

22.110 Switches in the **off position** shall disconnect electronic circuits.

Compliance is checked by inspection.

22.111 The appliance shall not automatically restart when the supply is re-established after a temporary disconnection, if restarting could result in a hazard, for example mechanical (moving parts) or thermal (hot parts or liquids).

Compliance is checked by the following test.

*The appliance is operated at **rated voltage** and in accordance with the instructions for use.*

At any time during the operating cycle the supply to the appliance is switched off and any moving parts are allowed to come to rest.

The supply is then restored.

22.112 Appliances shall be provided with a start switch and a stop switch. The stop switch shall be easily operated and shall override the start switch if simultaneously actuated.

Compliance is checked by inspection and by manual test.

NOTE An example of an easily operated stop switch is a projecting push-button switch.

22.113 Appliances fitted with wheels or similar means shall be provided with an efficient means of locking while the appliance is stationary.

Compliance is checked by inspection and by the following test.

The appliance, fully loaded in accordance with the manufacturer's instructions, is placed on a plane inclined at 10 ° to the horizontal, with the locking mechanism applied. The appliance shall not move by more than 100 mm.

23 Internal wiring

This clause of Part 1 is applicable except as follows.

23.3 Addition:

*When the capillary tube of the **thermostat** is liable to flexing in normal use the following applies:*

- where the capillary tube is fitted as part of the internal wiring, Part 1 applies;*
- where the capillary tube is separate, it shall be subjected to 1 000 flexings at a rate not exceeding 30 per minute.*

NOTE 101 If, in any of the above cases, it is not possible to move the movable part of the appliance at the given rate, due for example to the mass of the part, the rate of flexing may be reduced.

After the test, the capillary tube shall show no sign of damage within the meaning of this standard and no damage impairing its further use.

However, if a rupture of the capillary tube renders the appliance inoperative (fail-safe), separate capillary tubes are not tested, and those fitted as part of the internal wiring are not inspected for compliance with the requirements.

Compliance in this instance is checked by rupturing the capillary tube.

NOTE 102 Care must be taken to ensure that the rupture does not seal the capillary tube.

24 Components

This clause of Part 1 is applicable except as follows.

24.1.3 Modification:

Switches operating during each cycle of operation of the appliance are tested for 50 000 cycles of operation. Other switches are tested for 10 000 cycles of operation. Instead of the rate of operation specified, switches are tested at a rate of one operation per minute.

24.4 Addition:

Socket-outlets for the connection of accessories shall be protected against short circuit and/or overload.

25 Supply connection and external flexible cords

This clause of Part 1 is applicable except as follows.

25.1 Modification:

Appliances shall not be provided with an appliance inlet.

25.3 Addition:

Fixed appliances and appliances with a mass greater than 40 kg and not provided with rollers, castors or similar means shall be constructed so that the **supply cord** can be connected after the appliance has been installed in accordance with the manufacturer's instructions.

Terminals for permanent connection of cables to fixed wiring may also be suitable for the **type X attachment** of a **supply cord**. In this case a cord anchorage complying with 25.16 shall be fitted to the appliance.

If the appliance is provided with a set of terminals allowing the connection of a flexible cord, the terminals shall be suitable for the **type X attachment** of the cord.

In both cases the instructions shall give full particulars of the **supply cord**.

Compliance is checked by inspection.

25.7 *Modification:*

Instead of the types of **supply cords** specified, the following applies:

Supply cords shall be oil-resistant, sheathed flexible cable not lighter than ordinary polychloroprene or other equivalent synthetic elastomer-sheathed cord (code designation 60245 IEC 57).

26 Terminals for external conductors

This clause of Part 1 is applicable.

27 Provision for earthing

This clause of Part 1 is applicable except as follows.

27.2 *Addition:*

Stationary appliances shall be provided with a terminal for the connection of an external equipotential conductor. This terminal shall be in effective electrical contact with all fixed exposed metal parts of the appliance, and shall allow the connection of a conductor having a nominal cross-sectional area of up to 10 mm². It shall be located in a position convenient for the connection of the bonding conductor after installation of the appliance.

NOTE 101 Small fixed exposed metal parts, for example name-plates and the like, are not required to be in electrical contact with the terminal.

28 Screws and connections

This clause of Part 1 is applicable.

29 Clearances, creepage distances and solid insulation

This clause of Part 1 is applicable except as follows.

29.2 *Addition:*

The microenvironment is pollution degree 3 and the insulation shall have a comparative tracking index (CTI) not less than 250, unless the insulation is enclosed or located so that it is unlikely to be exposed to pollution during normal use of the appliance.

30 Resistance to heat and fire

This clause of Part 1 is applicable except as follows.

30.2.1 *Modification:*

The glow-wire test is carried out at 650 °C.

30.2.2 Not applicable

31 Resistance to rusting

This clause of Part 1 is applicable.

32 Radiation, toxicity and similar hazards

This clause of Part 1 is applicable.

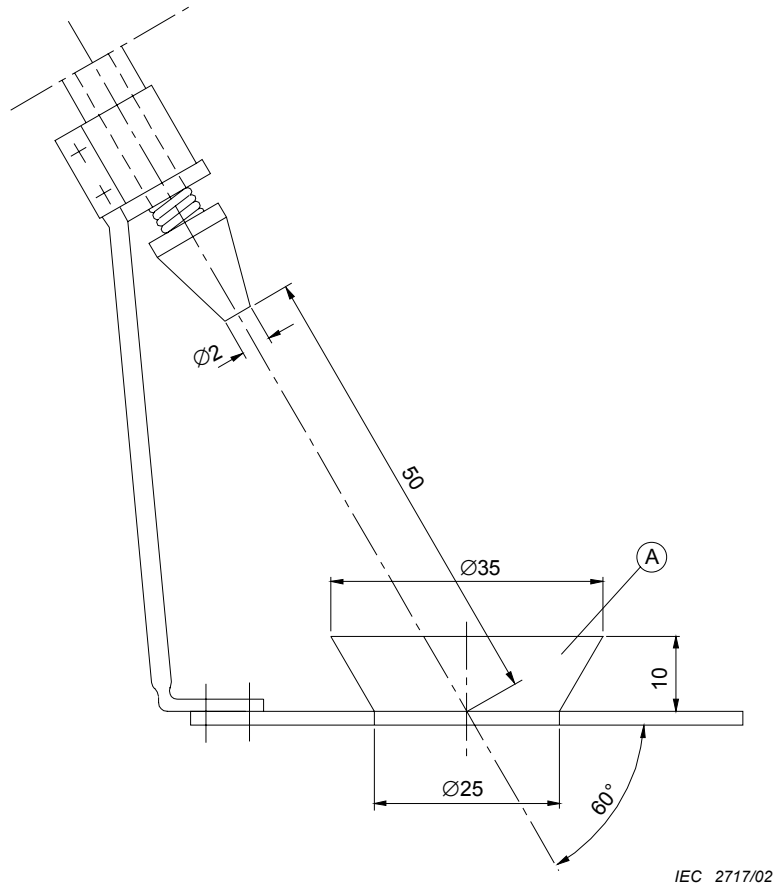

Dimensions in millimetres

Key

A Bowl

Figure 101 – Splash apparatus

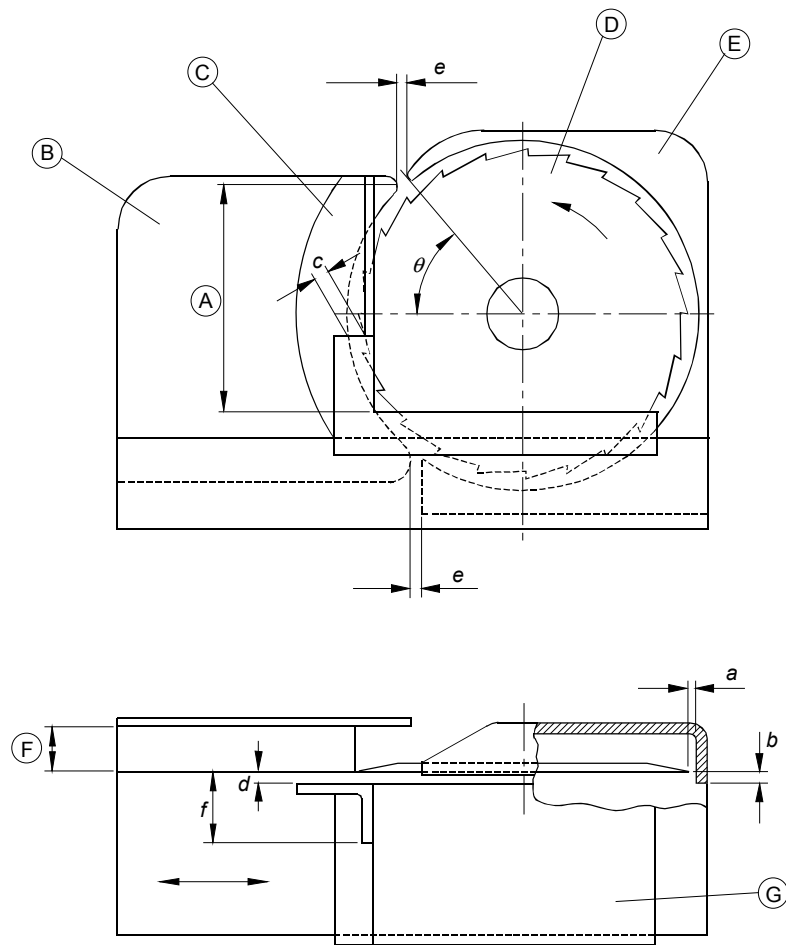

IEC 2207/02

Key

- A Full height of the open section
- B Plate that sets the thickness of the slices
- C Thumb guard
- D Rotating blade
- E Blade guard
- F Thickness of slices
- G Sliding feed table

Figure 102 – Protection devices for slicing machines

Annexes

The annexes of Part 1 are applicable except as follows.

Annex N (normative)

Proof tracking test

6.3 Addition:

Add 250 V to the list of specified voltages.

Bibliography

The bibliography of Part 1 is applicable.

LICENSED TO MECON Limited. - RANCHI/BANGALORE
FOR INTERNAL USE AT THIS LOCATION ONLY, SUPPLIED BY BOOK SUPPLY BUREAU.

INTERNATIONAL
ELECTROTECHNICAL
COMMISSION

3, rue de Varembé
P.O. Box 131
CH-1211 Geneva 20
Switzerland

Tel: + 41 22 919 02 11
Fax: + 41 22 919 03 00
info@iec.ch
www.iec.ch