

INTERNATIONAL STANDARD



**Household and similar electrical appliances – Safety –
Part 2-36: Particular requirements for commercial electric cooking ranges,
ovens, hobs and hob elements**



THIS PUBLICATION IS COPYRIGHT PROTECTED
Copyright © 2017 IEC, Geneva, Switzerland

All rights reserved. Unless otherwise specified, no part of this publication may be reproduced or utilized in any form or by any means, electronic or mechanical, including photocopying and microfilm, without permission in writing from either IEC or IEC's member National Committee in the country of the requester. If you have any questions about IEC copyright or have an enquiry about obtaining additional rights to this publication, please contact the address below or your local IEC member National Committee for further information.

IEC Central Office
3, rue de Varembe
CH-1211 Geneva 20
Switzerland

Tel.: +41 22 919 02 11
Fax: +41 22 919 03 00
info@iec.ch
www.iec.ch

About the IEC

The International Electrotechnical Commission (IEC) is the leading global organization that prepares and publishes International Standards for all electrical, electronic and related technologies.

About IEC publications

The technical content of IEC publications is kept under constant review by the IEC. Please make sure that you have the latest edition, a corrigenda or an amendment might have been published.

IEC Catalogue - webstore.iec.ch/catalogue

The stand-alone application for consulting the entire bibliographical information on IEC International Standards, Technical Specifications, Technical Reports and other documents. Available for PC, Mac OS, Android Tablets and iPad.

IEC publications search - www.iec.ch/searchpub

The advanced search enables to find IEC publications by a variety of criteria (reference number, text, technical committee,...). It also gives information on projects, replaced and withdrawn publications.

IEC Just Published - webstore.iec.ch/justpublished

Stay up to date on all new IEC publications. Just Published details all new publications released. Available online and also once a month by email.

Electropedia - www.electropedia.org

The world's leading online dictionary of electronic and electrical terms containing 20 000 terms and definitions in English and French, with equivalent terms in 16 additional languages. Also known as the International Electrotechnical Vocabulary (IEV) online.

IEC Glossary - std.iec.ch/glossary

65 000 electrotechnical terminology entries in English and French extracted from the Terms and Definitions clause of IEC publications issued since 2002. Some entries have been collected from earlier publications of IEC TC 37, 77, 86 and CISPR.

IEC Customer Service Centre - webstore.iec.ch/csc

If you wish to give us your feedback on this publication or need further assistance, please contact the Customer Service Centre: csc@iec.ch.



IEC 60335-2-36

Edition 6.0 2017-04

INTERNATIONAL STANDARD



**Household and similar electrical appliances – Safety –
Part 2-36: Particular requirements for commercial electric cooking ranges,
ovens, hobs and hob elements**

INTERNATIONAL
ELECTROTECHNICAL
COMMISSION

ICS 97.040.20

ISBN 978-2-8322-4169-1

Warning! Make sure that you obtained this publication from an authorized distributor.

CONTENTS

FOREWORD.....	4
INTRODUCTION.....	7
1 Scope.....	8
2 Normative references	8
3 Terms and definitions	9
4 General requirement.....	11
5 General conditions for the tests	11
6 Classification.....	12
7 Marking and instructions.....	12
8 Protection against access to live parts.....	15
9 Starting of motor-operated appliances	16
10 Power input and current.....	16
11 Heating.....	17
12 <i>Void</i>	18
13 Leakage current and electric strength at operating temperature.....	18
14 Transient overvoltages	19
15 Moisture resistance	19
16 Leakage current and electric strength.....	20
17 Overload protection of transformers and associated circuits	22
18 Endurance	22
19 Abnormal operation	22
20 Stability and mechanical hazards.....	24
21 Mechanical strength	25
22 Construction	26
23 Internal wiring.....	27
24 Components	27
25 Supply connection and external flexible cords	28
26 Terminals for external conductors.....	28
27 Provision for earthing	28
28 Screws and connections	28
29 Clearances, creepage distances and solid insulation	29
30 Resistance to heat and fire	29
31 Resistance to rusting	30
32 Radiation, toxicity and similar hazards.....	30
Annexes	32
Annex N (normative) Proof tracking test.....	33
Annex P (informative) Guidance for the application of this standard to appliances used in tropical climates	34
Bibliography.....	35
Figure 101 – Identification of surfaces for temperature measurement	31
Figure 102 – Probe for measuring surface temperatures	31

Figure 103 – Splash apparatus 31

Figure 104 – Concavity of disc 32

Table 101 – Maximum temperature rises for specified external accessible surfaces
under normal operating conditions 18

Table 102 – Assembling torques for screwed connections providing earthing continuity 29

INTERNATIONAL ELECTROTECHNICAL COMMISSION

HOUSEHOLD AND SIMILAR ELECTRICAL APPLIANCES – SAFETY –**Part 2-36: Particular requirements for commercial electric cooking ranges, ovens, hobs and hob elements**

FOREWORD

- 1) The International Electrotechnical Commission (IEC) is a worldwide organization for standardization comprising all national electrotechnical committees (IEC National Committees). The object of IEC is to promote international co-operation on all questions concerning standardization in the electrical and electronic fields. To this end and in addition to other activities, IEC publishes International Standards, Technical Specifications, Technical Reports, Publicly Available Specifications (PAS) and Guides (hereafter referred to as "IEC Publication(s)"). Their preparation is entrusted to technical committees; any IEC National Committee interested in the subject dealt with may participate in this preparatory work. International, governmental and non-governmental organizations liaising with the IEC also participate in this preparation. IEC collaborates closely with the International Organization for Standardization (ISO) in accordance with conditions determined by agreement between the two organizations.
- 2) The formal decisions or agreements of IEC on technical matters express, as nearly as possible, an international consensus of opinion on the relevant subjects since each technical committee has representation from all interested IEC National Committees.
- 3) IEC Publications have the form of recommendations for international use and are accepted by IEC National Committees in that sense. While all reasonable efforts are made to ensure that the technical content of IEC Publications is accurate, IEC cannot be held responsible for the way in which they are used or for any misinterpretation by any end user.
- 4) In order to promote international uniformity, IEC National Committees undertake to apply IEC Publications transparently to the maximum extent possible in their national and regional publications. Any divergence between any IEC Publication and the corresponding national or regional publication shall be clearly indicated in the latter.
- 5) IEC itself does not provide any attestation of conformity. Independent certification bodies provide conformity assessment services and, in some areas, access to IEC marks of conformity. IEC is not responsible for any services carried out by independent certification bodies.
- 6) All users should ensure that they have the latest edition of this publication.
- 7) No liability shall attach to IEC or its directors, employees, servants or agents including individual experts and members of its technical committees and IEC National Committees for any personal injury, property damage or other damage of any nature whatsoever, whether direct or indirect, or for costs (including legal fees) and expenses arising out of the publication, use of, or reliance upon, this IEC Publication or any other IEC Publications.
- 8) Attention is drawn to the Normative references cited in this publication. Use of the referenced publications is indispensable for the correct application of this publication.
- 9) Attention is drawn to the possibility that some of the elements of this IEC Publication may be the subject of patent rights. IEC shall not be held responsible for identifying any or all such patent rights.

This part of International Standard IEC 60335 has been prepared by IEC technical committee 61: Safety of household and similar electrical appliances.

This sixth edition cancels and replaces the fifth edition published in 2002 including its Amendment 1 (2004) and its Amendment 2 (2008). It constitutes a technical revision.

The principle changes in this edition as compared with the fifth edition of IEC 60335-2-36 are as follows (minor changes are not listed):

- stating some wording in the scope more precisely;
- addition of a measurement method for pans in the definition for **normal operation**;
- new definitions on the topic surface temperature;
- deletion of the paragraph with the warning for dangerous voltages (already covered by Part 1);

- addition of hot surface symbol IEC 60417-5041;
- addition of instructions and markings on hot surfaces and other topics;
- addition of requirements, measuring methods and thresholds for different materials on hot surfaces;
- modification on leakage current defining the value for appliances with a power consumption less than 1 kW;
- modification on the measurement method for induction heating sources in abnormal operation;
- addition of a requirement for the construction of stationary appliances with rollers or castors;
- modification on some points concerning permanent connection to fixed wiring;
- addition of specific requirements concerning types of screws to be used for electrical connections and connections for earth continuity;
- addition of a figure showing the surfaces to be measured;
- addition of a figure showing the probe for measuring surface temperatures;
- addition of a figure showing the disc for the pan detection on induction heating sources;
- addition of informative Annex P dealing with leakage currents for appliances used in tropical climates.

The text of this Standard is based on the following documents:

FDIS	Report on voting
61/5327/FDIS	61/5383/RVD

Full information on the voting for the approval of this International Standard can be found in the report on voting indicated in the above table.

This document has been drafted in accordance with the ISO/IEC Directives, Part 2.

A list of all parts of the IEC 60335 series, under the general title: *Household and similar electrical appliances – Safety*, can be found on the IEC website.

This part 2 is to be used in conjunction with the latest edition of IEC 60335-1 and its amendments. It was established on the basis of the fifth edition (2010) of that standard.

NOTE 1 When "Part 1" is mentioned in this standard, it refers to IEC 60335-1.

This part 2 supplements or modifies the corresponding clauses in IEC 60335-1, so as to convert that publication into the IEC standard: Safety requirements for commercial electric cooking ranges, ovens, hobs and hob elements.

When a particular subclause of Part 1 is not mentioned in this part 2, that subclause applies as far as is reasonable. When this standard states "addition", "modification" or "replacement", the relevant text in Part 1 is to be adapted accordingly.

NOTE 2 The following numbering system is used:

- subclauses, tables and figures that are numbered starting from 101 are additional to those in Part 1;
- unless notes are in a new subclause or involve notes in Part 1, they are numbered starting from 101, including those in a replaced clause or subclause;
- additional annexes are lettered AA, BB, etc.

NOTE 3 The following print types are used:

- requirements: in roman type;

- *test specifications: in italic type;*
- notes: in small roman type.

Words in **bold** in the text are defined in Clause 3. When a definition of Part 1 concerns an adjective, the adjective and the associated noun are also in bold .

The committee has decided that the contents of this document will remain unchanged until the stability date indicated on the IEC website under "<http://webstore.iec.ch>" in the data related to the specific document. At this date, the document will be

- reconfirmed,
- withdrawn,
- replaced by a revised edition, or
- amended.

NOTE 4 The attention of National Committees is drawn to the fact that equipment manufacturers and testing organizations may need a transitional period following publication of a new, amended or revised IEC publication in which to make products in accordance with the new requirements and to equip themselves for conducting new or revised tests.

It is the recommendation of the committee that the content of this publication be adopted for implementation nationally not earlier than 12 months from the date of publication.

IMPORTANT – The 'colour inside' logo on the cover page of this publication indicates that it contains colours which are considered to be useful for the correct understanding of its contents. Users should therefore print this document using a colour printer.

INTRODUCTION

It has been assumed in the drafting of this International Standard that the execution of its provisions is entrusted to appropriately qualified and experienced persons.

This standard recognizes the internationally accepted level of protection against hazards such as electrical, mechanical, thermal, fire and radiation of appliances when operated as in normal use taking into account the manufacturer's instructions. It also covers abnormal situations that can be expected in practice and takes into account the way in which electromagnetic phenomena can affect the safe operation of appliances.

This standard takes into account the requirements of IEC 60364 as far as possible so that there is compatibility with the wiring rules when the appliance is connected to the supply mains. However, national wiring rules may differ.

If an appliance within the scope of this standard also incorporates functions that are covered by another part 2 of IEC 60335, the relevant part 2 is applied to each function separately, as far as is reasonable. If applicable, the influence of one function on the other is taken into account.

This standard is a product family standard dealing with the safety of appliances and takes precedence over horizontal and generic standards covering the same subject.

NOTE 2 Horizontal and generic standards covering a hazard are not applicable since they have been taken into consideration when developing the general and particular requirements for the IEC 60335 series of standards. For example, in the case of temperature requirements for surfaces on many appliances, generic standards, such as ISO 13732-1 for hot surfaces, are not applicable in addition to Part 1 or part 2 standards.

An appliance that complies with the text of this standard will not necessarily be considered to comply with the safety principles of the standard if, when examined and tested, it is found to have other features that impair the level of safety covered by these requirements.

An appliance employing materials or having forms of construction differing from those detailed in the requirements of this standard may be examined and tested according to the intent of the requirements and, if found to be substantially equivalent, may be considered to comply with the standard.

HOUSEHOLD AND SIMILAR ELECTRICAL APPLIANCES – SAFETY –

Part 2-36: Particular requirements for commercial electric cooking ranges, ovens, hobs and hob elements

1 Scope

This clause of Part 1 is replaced by the following.

This International Standard deals with the safety of electrically operated commercial **cooking and baking ranges**, ovens, **hobs, hob elements** and similar appliances not intended for household and similar use, their **rated voltage** being not more than 250 V for single-phase appliances connected between one phase and neutral and 480 V for other appliances.

NOTE 101 These appliances are used for the commercial processing of food, for example in kitchens of restaurants, canteens, hospitals and in commercial enterprises such as bakeries, butcheries, etc.

The electrical part of appliances making use of other forms of energy is also within the scope of this standard.

As far as is practicable, this standard deals with the common hazards presented by these types of appliances.

NOTE 102 Attention is drawn to the fact that

- For appliances intended to be used in vehicles or on board ships or aircraft, additional requirements may be necessary;
- In many countries additional requirements are specified by the national health authorities, the national authorities responsible for the protection of labour, the national water supply authorities and similar authorities.

NOTE 103 This standard does not apply to

- appliances designed exclusively for industrial purposes;
- appliances intended to be used in locations where special conditions prevail, such as the presence of a corrosive or explosive atmosphere (dust, vapour or gas);
- appliances for continuous mass production of food;
- steam cookers, forced and steam convection ovens (IEC 60335-2-42);
- hot cupboards (IEC 60335-2-49);
- microwave ovens (IEC 60335-2-90).

2 Normative references

This clause of Part 1 is applicable except as follows.

Addition:

IEC 60584-1, *Thermocouples – Part 1: EMF specifications and tolerances*

ISO 185, *Grey cast irons – Classifications*

ISO 898-1, *Mechanical properties of fasteners made of carbon steel and alloy steel – Part 1: Bolts, screws and studs with specified property classes – Coarse thread and fine pitch thread*

ISO 3506-1, *Mechanical properties of corrosion-resistant stainless steel fasteners – Part 1: Bolts, screws and studs*

ISO 3506-2, *Mechanical properties of corrosion-resistant stainless steel fasteners – Part 2: Nuts*

ISO 3506-3, *Mechanical properties of corrosion-resistant stainless steel fasteners – Part 3: Set screws and similar fasteners not under tensile stress*

ISO 3506-4, *Mechanical properties of corrosion-resistant stainless steel fasteners – Part 4: Tapping screws*

3 Terms and definitions

This clause of Part 1 is applicable except as follows.

3.1.4 Addition:

Note 1 to entry: The **rated power input** is the sum of the power inputs of all the individual elements in the appliance that can be on at one time; where several such combinations are possible, that giving the highest power input is used in determining the **rated power input**.

3.1.9 Replacement:

normal operation

operation of the appliance under the following conditions:

Solid **hob elements** are operated with no load and sheathed **hob elements** are operated with a load made of dull black, cold or hot rolled steel, 9 mm to 10 mm thick, that covers not less than 90 % and not more than 100 % of the element surface. The **hob elements** are operated with the controls set to give the temperatures as set out below, the temperature being measured at the geometrical centre or the hottest point of the solid element or load, if the element is unevenly heated.

Stepped controls are set to the first position that gives a temperature equal to or greater than 275 °C. Cycling controls are set so that the mean value of the temperature over the cycle is 275 °C ± 5 °C. If this temperature cannot be reached, the control is set at the maximum.

Non-induction heating sources beneath a glass-ceramic or similar material are operated with a pan or pans containing initially cold water, the pan(s) being filled to a height of 60 mm ± 10 mm. The pan or pans are of aluminium, of ordinary quality, not brightly polished, with a base concavity not exceeding 0,1 mm. The pan or pans shall cover the **cooking zone** to the greatest extent possible.

The pan or pans are covered with a lid. The controls are set at maximum until the water boils and then adjusted to maintain boiling. Water is added to maintain the water level during boiling.

Induction heating sources beneath a glass-ceramic or similar material are operated with the pan or pans recommended by the manufacturer.

If one pan is used, it shall cover as closely as possible, but not less than, the full area of the **cooking zone**. The pan is positioned centrally.

For non-circular **cooking zones** a combination of the smallest number of pans is chosen to cover as much as possible the area of the **cooking zone**.

The pan or pans in each case are filled with initially cold frying oil to a height of 30 mm ± 5 mm. The controls are set to maximum until the temperature of the oil attains a value of 180 °C and then adjusted to maintain the oil at a temperature of 180 °C ± 15 °C. The oil temperature is measured 10 mm above the centre of the bottom of the vessel.

A further test is made using initially cold water, the pan(s) being filled to a height of 60 mm ± 10 mm. The pan or pans are covered with a lid. The controls are set at maximum

until the water boils and then adjusted to maintain boiling. Water is added to maintain the water level during boiling.

The condition providing the most unfavourable results (oil or water) is used.

Ovens are operated with no load and with the controls set so that the mean value of the temperature over the thermostat cycle at the geometric centre of the usable space in the interior of the oven is maintained at $240\text{ °C} \pm 4\text{ °C}$. Stepped controls are set so that this temperature is $240\text{ °C} \pm 15\text{ °C}$. For ovens that are capable of attaining temperatures in excess of 290 °C , the controls are set so that the temperature is $50\text{ °C} \pm 4\text{ °C}$ below the maximum temperature attainable. For ovens that are unable to attain a temperature of 240 °C , the controls are set to maximum.

Griddle plates are operated with no load and with the controls set so as to give the temperatures set out below, the temperature being measured at the hottest point of each controlled cooking surface. Stepped controls are set to the first position that gives a temperature equal to or greater than 275 °C . Cycling controls are set so that the mean value of the temperature over the cycle is $275\text{ °C} \pm 5\text{ °C}$. If this temperature cannot be reached, the control is set to maximum.

Motors incorporated in the appliance are operated in the intended manner under the most unfavourable conditions that can be expected in normal use, taking into account the manufacturer's instructions.

3.101

cooking and baking range

single cooking or baking appliance incorporating one or more ovens together with one or more **hob elements** or **griddle plates** or a combination of these

Note 1 to entry: An appliance incorporating a forced convection oven, steam-convection oven or microwave oven is considered to be an appliance incorporating another appliance (see also 5.102).

3.102

heating unit

any part of the appliance that fulfils an independent cooking or heating function

Note 1 to entry: Examples are **hob elements**, **griddle plates** or ovens.

Note 2 to entry: If an oven incorporates more than one heating element or groups of elements that are so controlled that one element or group cannot be switched on while another element or group is energized, each of the elements or groups of elements is to be considered as a separate **heating unit** and tested accordingly.

3.103

hob element

heating unit designed to accommodate a vessel or vessels on its upper surface

Note 1 to entry: A **hob element** may consist of an **induction** or non-induction **heating source** beneath a surface of glass-ceramic or similar material.

3.104

hob surface

horizontal part of the appliance to which the **hob elements** are attached

Note 1 to entry: It may be a separate appliance or part of a **cooking range**.

Note 2 to entry: A **hob** may also incorporate a **griddle plate**.

3.105

hob

hob surface and one or more **hob elements**

3.106**cooking zone**

area marked on a **hob surface** of glass-ceramic or similar material where the vessel is intended to be placed

3.107**induction heating source**

heating source that operates by inducing eddy currents in a vessel positioned on the **hob element**

3.108**griddle plate**

heating unit having a cooking surface on which the food is intended to be placed directly

3.109**installation wall**

special fixed construction containing supply facilities for appliances installed in conjunction with it

3.110**pan detector**

device incorporated in a **hob element** that prevents its operation unless a vessel is placed on the **cooking zone**

Note 1 to entry: A **pan detector** is not considered to be a **thermostat** or **protective device**.

3.111**functional surface**

surface that is intentionally heated by an internal heat source and has to be hot to carry out the function for which the appliance is intended

Note 1 to entry: An example is the heated sheath of a tubular heating element.

3.112**adjacent surface**

surface adjacent to a **functional surface** and which can become hot through conduction

4 General requirement

This clause of Part 1 is applicable.

5 General conditions for the tests

This clause of Part 1 is applicable except as follows.

5.2 Addition:

Hob elements that are submitted separately are tested when installed in an appropriate **cooking range**.

The test of 18.102 may be made on a separate sample.

5.3 Addition:

The test of 18.102 is made before the test of Clause 11 unless it is made on a separate sample.

5.10 Addition:

Appliances intended for installation in a bank of other appliances and appliances intended to be fixed to an installation wall are enclosed to obtain protection against electric shock and harmful ingress of water equivalent to that obtained when installed in accordance with the instructions provided with the appliances.

NOTE 101 Appropriate enclosures or additional appliances may be needed for test purposes.

5.101 *Appliances are tested as **heating appliances**, even if they incorporate a motor.*

5.102 *Appliances, when assembled in combination with or incorporating other appliances, are tested in accordance with the requirements of this standard. The other appliances are operated simultaneously in accordance with the requirements of the relevant standards.*

6 Classification

This clause of Part 1 is applicable except as follows.

6.1 Replacement:

Appliances shall be **class I** with respect to protection against electric shock.

Compliance is checked by inspection and by the relevant tests.

6.2 Addition:

Appliances normally used on a table shall be at least IPX3. Other appliances shall be at least IPX4.

7 Marking and instructions

This clause of Part 1 is applicable except as follows.

7.1 Addition:

Appliances incorporating **induction heating sources** shall be marked with

- operating frequency or operating frequency range in kilohertz (kHz) of the **induction heating sources**;
- the total power input of all the induction **heating units** that can operate simultaneously, in watts or kilowatts;

NOTE 101 The power input to be marked or declared is the highest power input any switching arrangement will allow.

- the total power input of all the non-induction **heating units** that can operate simultaneously in watts or kilowatts.

NOTE 102 The power input to be marked is the highest power input any switching arrangement will allow.

Covers, if removed, giving direct access to induction coils shall be marked with the following:

CAUTION: MAGNETIC FIELD or symbol IEC 60417-5140 (2003-04).

If appliances have external **accessible surfaces**, for which temperature rise limits are specified in Table 101 and for which the provisions of footnote b to Table 101 apply, then the

appliance shall be marked with symbol IEC 60417-5041 (2002-10), or with the substance of the following:

CAUTION: Hot surfaces.

7.6 Addition:



[symbol IEC 60417-5140 (2003-04)] non-ionizing electromagnetic radiation



[symbol IEC 60417-5041 (2002-10)] caution, hot surface

7.12 Addition:

If the appliance incorporates a **hob surface** of glass-ceramic or similar material that provides the enclosure of **live parts**, the instructions shall include the substance of the following warning:

WARNING: If the surface is cracked, immediately disconnect the appliance or appropriate part of the appliance from the supply.

The instructions for appliances with **hob surfaces** of glass-ceramic or similar material shall state that aluminium foil and plastic vessels are not to be placed on the hot surfaces. They shall also state that these surfaces are not to be used for storage.

The instructions for **hobs** incorporating halogen lamps shall warn the user to avoid looking directly at the lamps when on.

The instructions for appliances incorporating **induction heating sources** shall indicate the size of the smallest cooking vessel to be used. They shall also include the substance of the following:

- metallic objects such as kitchen utensils, cutlery etc. shall not be placed on the **hob surface** within the **cooking zones** since they could get hot;
- take care when operating the appliance, as rings, watches and similar objects worn by the user could get hot when in close proximity to the **hob surface**;
- only use vessels of the type and size recommended.

The instructions for appliances incorporating **induction heating sources** shall state that users with heart pacemakers should consult with the manufacturer, unless specific details are given.

The instructions for **hobs** with **hob elements** incorporating **pan detectors** shall include the substance of the following:

After use, switch the **hob element** off by means of its control. Do not rely on the **pan detector**.

If any of symbols IEC 60417-5021 (2002-10), IEC 60417-5036 (2002-10), IEC 60417-5041 (2002-10) or IEC 60417-5140 (2003-04) are marked on the appliance, their meaning shall be explained.

The instructions shall include the substance of the following:

These appliances are intended to be used for commercial applications, for example in kitchens of restaurants, canteens, hospitals and in commercial enterprises such as bakeries, butcheries, etc., but not for continuous mass production of food.

If the manufacturer wants to limit the use of the appliance to less than the above, this has to be clearly stated in the instructions.

Modification:

The instruction concerning persons (including children) with reduced physical, sensory or mental capabilities, or lack of experience and knowledge is not applicable.

7.12.1 *Addition:*

For appliances intended for installation in a bank of other appliances and appliances intended to be fixed to an **installation wall**, details of how to ensure appropriate protection against electric shock and harmful ingress of water shall be supplied. If the controls of more than one appliance are combined in a separate enclosure, detailed installation instructions shall be supplied. Instructions for **user maintenance**, for example cleaning, shall also be given. They shall include a statement that the appliance is not to be cleaned with a water jet or a steam cleaner.

For appliances that are permanently connected to fixed wiring and for which leakage currents may exceed 10 mA, particularly if disconnected or not used for long periods, or during initial installation, the instruction sheet shall give recommendations regarding the rating of **protective devices**, such as residual current devices (RCD), to be installed.

In addition, for appliances incorporating **induction heating sources**, the instructions shall state that any repairs shall be carried out only by persons trained or recommended by the manufacturer.

If a **stationary appliance** is intended to be moved for cleaning, this shall be stated.

For **stationary appliances** equipped with rollers or castors or intended to be moved for cleaning, the instructions shall state the substance of the following.

This appliance is to be connected with flexible connections for equipotential bonding and connection to services such as electricity supply, water supply, gas supply and steam supply such that the appliance can be moved in the direction required for cleaning a distance not less than the dimension of the appliance in the direction of movement plus 500 mm without the flexible connections becoming taut or being subject to strain.

7.12.4 *Addition:*

For appliances incorporating **induction heating sources**, a warning that care be taken to ensure that the splashback and surrounding area are free of metallic surfaces, if this is necessary due to the design of the appliance. The instructions for **built-in appliances** having a separate control panel for several appliances shall state that the control panel is only to be connected to the specified appliances in order to avoid a possible hazard.

7.12.9 Not applicable.

7.14 *Addition:*

The height of the triangle in symbol IEC 60417-5041 (2002-10) shall be at least 15 mm.

7.15 *Addition:*

The marking specified for external **accessible surfaces** shall be visible when the appliance is operated as in normal use, including when actuating any switch, adjusting any control or opening a lid or door. It shall not be placed on a **functional surface** or **adjacent surface**.

Modification:

For **fixed appliances**, the marking of the name or trademark or identification mark of the manufacturer or responsible vendor and the model or type reference shall be marked on the appliance and, if not visible when the appliance is installed as in normal use, shall be included in the instructions or on an additional label that can be fixed near the appliance after installation.

NOTE 101 An example of such an appliance is a **built-in hob**.

7.101 If, during the test of Clause 11, the temperature rise of the side and rear walls of the test corner above the level of the hob surface exceeds 65 K or during the test of Clause 19 the temperature rise of the walls above and below the hob surface exceeds 125 K, the installation instructions provided by the manufacturer shall include the substance of the following that shall also be included on a non-permanent label, for example a tie-on type, attached to the appliance:

Where this appliance is to be positioned in close proximity to a wall, partitions, kitchen furniture, decorative finishes, etc., it is recommended that they be made of non-combustible material, or if not, that they shall be clad with a suitable non-combustible heat-insulating material.

Compliance is checked by inspection.

7.102 The **cooking zones** of **hob surfaces** of glass-ceramic or similar material shall be clearly identified by appropriate marking, unless they are obvious.

Compliance is checked by inspection.

7.103 Equipotential bonding terminals shall be marked with symbol 60417-5021 (2002-10).

These markings shall not be placed on screws, removable washers or other parts that can be removed when conductors are being connected.

Compliance is checked by inspection.

8 Protection against access to live parts

This clause of Part 1 is applicable except as follows.

8.1 Addition:

Appliances intended to accommodate detachable **hob elements** shall be constructed so that there is adequate protection against accidental contact with **live parts** during insertion or removal of these elements.

8.101 Heating elements that are liable to be touched accidentally by a fork or similar pointed object in normal use shall be so protected that it is not possible to touch their **live parts** with such an object.

Compliance is checked by inserting test probe 12 of IEC 61032 at all points where the probe can enter in the vicinity of live parts. The probe is applied with a force not exceeding 1 N.

9 Starting of motor-operated appliances

This clause of Part 1 is applicable except as follows.

9.101 Fan motors providing a cooling effect in order to comply with the requirements of Clause 11 shall start under all voltage conditions that may occur in use.

Compliance is checked by the following tests using a supply source such that its drop in voltage does not exceed 1 % during the tests. The appliance being returned to the ambient temperature specified in 5.7 after each test.

*The appliance is started under the conditions occurring at the beginning of **normal operation** or, for automatic appliances, at the beginning of the normal cycle of operation,—a voltage equal to 0,85 times **rated voltage** being applied to the input terminals of the appliance.*

*For appliances provided with motors having other than centrifugal starting switches, this test is repeated at a voltage equal to 1,06 times **rated voltage** being applied to the input terminals of the appliance.*

The tests are carried out three times.

*In all cases, the motor shall start and it shall function in such a way that safety is not affected and overload **protection devices** of the motor shall not operate.*

10 Power input and current

This clause of Part 1 is applicable except as follows.

10.1 Modification:

The power input of appliances without induction heating sources, at rated voltage and at normal operating temperature, shall not deviate from the rated power input by more than the deviation shown in Table 1.

The power input of appliances having only induction heating sources, at rated voltage and at normal operating temperature, shall not exceed from the rated power input by more than 10 %.

The measurement is made before the controls are adjusted to the reduced setting.

For appliances incorporating induction and non-induction heating sources the following applies.

The power input of the induction heating sources and the non-induction heating sources is measured separately, in each case using a combination of heating units that can be on at the same time to give the highest power input. For the induction heating sources, the measurement is made before the controls are adjusted to the reduced setting.

The power inputs so measured shall in the case of the induction heating sources not deviate from the power input marked by the manufacturer (see 7.1) by more than 10 %, and in the case of the non-induction heating sources not deviate from the power input marked by the manufacturer (see 7.1) by more than that given in Table 1 for heating appliances.

The power input of the appliance when the induction and non-induction heating sources are operated simultaneously shall not deviate from the rated power input by more than 10 %.

For appliances having more than one **heating unit**, the total power input may be determined by measuring the power input of each **heating unit** separately (see also 3.1.4).

11 Heating

This clause of Part 1 is applicable except as follows.

11.2 Addition:

*Appliances intended to be fixed to the floor and appliances with a mass greater than 40 kg and not provided with rollers, castors or similar means are installed in accordance with the manufacturer's instructions. If no instructions are given, these appliances are considered as **appliances normally placed on the floor**.*

11.3 Addition:

*If the magnetic field of an **induction heating source** unduly influences the results, the temperature rises can be determined using platinum resistances with twisted connecting wires or any equivalent means.*

*Where the external **accessible surfaces** are suitably flat and access permits, then the test probe of Figure 102 is used to measure the temperature rises of external **accessible surfaces** specified in Table 101. The probe is applied with a force of $4\text{ N} \pm 1\text{ N}$ to the surface in such a way that the best possible contact between the probe and the surface is ensured. The measurement is performed after a contact period of 30 s.*

The probe may be held in place using a laboratory stand clamp or similar device. Any measuring instrument giving the same results as the probe may be used.

11.4 Replacement:

The non-induction heating units of the appliance are operated under normal operation at 1,15 times the power input marked (see 7.1).

If the temperature rise limits of motors, transformers or electronic circuits are exceeded, the test is repeated with the appliance supplied at 1,06 times rated voltage. In this case, only the temperature rises of motors, transformers and electronic circuits are measured.

Induction heating units are operated simultaneously and supplied separately at the most unfavourable voltage between 0,94 times minimum rated voltage and 1,06 times maximum rated voltage.

If it is not possible to switch on all heating elements or induction heating sources at the same time, the test is made with each of the combinations that the switch arrangement will allow, the highest load possible with each switching arrangement being in circuit.

If the appliance is provided with a control that limits the total power input, the test is made with whichever combination of heating units, as may be selected by the control, imposes the severest condition.

In addition, appliances incorporating induction heating sources are also operated as above, but with the smallest size of pan as recommended by the manufacturer placed in the most onerous position consistent with being able to energize the coil, but within the cooking zone.

NOTE 101 The additional operating condition described above is not applied when reference to Clause 11 is made in other tests.

11.7 Replacement:

Appliances are operated until steady conditions are established.

Steady conditions are considered to exist 60 min after reaching the temperatures defined for normal operation.

When an appliance is assembled in combination with, equipped with or incorporating accessories or other appliances the interaction shall be covered if they are provided to operate simultaneously as stated by the manufacturer or by a common control.

11.8 Addition:

The limit of 65 K temperature rise for the rear and side test walls, including the part of the test corner that projects in front of the appliance, only applies below the level of the hob surface. If this temperature rise limit is exceeded above the hob surface then the instructions in 7.101 shall be provided.

During the test, the temperature rises are monitored continuously and shall not exceed the values shown in Table 3 and Table 101.

Table 101 – Maximum temperature rises for specified external accessible surfaces under normal operating conditions

<i>Surface^a</i>	<i>Temperature rise of external accessible surfaces^b K</i>
<i>Bare metal</i>	<i>48</i>
<i>Coated metal^c</i>	<i>59</i>
<i>Glass and ceramic</i>	<i>65</i>
<i>Plastic and plastic coating > 0,4 mm^{d, e}</i>	<i>74</i>
<p>^a <i>Temperature rises are not measured on:</i></p> <ul style="list-style-type: none"> – <i>the underside of appliances intended to be used on a working surface or floor;</i> – <i>the rear surface of appliances;</i> – <i>surfaces that are inaccessible to a 75 mm diameter probe having a hemispherical end</i> – <i>the area up to 60 mm around a heated cavity door opening;</i> – <i>functional surfaces and adjacent surfaces.</i> <p>^b <i>The temperature rise on external accessible surfaces up to a distance of 100 mm from adjacent surfaces of the appliance, (see Figure 101) may exceed the limits by up to 25 K, but the relevant part shall then be marked with symbol IEC 60417-5041 (2002-10) or the equivalent text.</i></p> <p>^c <i>Metal is considered coated when a coating having a minimum thickness of 90 µm made by enamel or non-substantially plastic coating is used.</i></p> <p>^d <i>The temperature rise limit of plastic also applies for plastic material having a metal finish of thickness less than 0,1 mm.</i></p> <p>^e <i>When the thickness of the plastic coating does not exceed 0,4 mm, the temperature rise limits of coated metal for underlying metal apply or the temperature rise limits for glass or ceramic material for underlying glass or ceramic material apply.</i></p>	

12 Void

13 Leakage current and electric strength at operating temperature

This clause of Part 1 is applicable except as follows.

13.1 Modification:

The appliance is operated under the conditions specified in Clause 11 until the leakage current has reached a steady value or for the duration specified in 11.7, whichever is the shorter period.

If more than one pan is placed on a single cooking zone, they are electrically connected together.

13.2 Modification:

Instead of the permissible leakage current for stationary class I appliances, the following applies:

- *for cord and plug connected appliances* *0,75 mA or 1 mA per kW **rated power input** of the appliance with a maximum of 10 mA, whichever is higher.*
- *for other appliances* *0,75 mA or 1 mA per kW **rated power input** of the appliance with no maximum, whichever is higher.*

For portable class I appliances, instead of the permissible leakage current, the following applies:

- *for cord and plug connected appliances* *0,75 mA or 1 mA per kW **rated power input** of the appliance with a maximum of 10 mA, whichever is higher.*

13.3 Addition:

If there is earthed metal between live parts and the surface of glass-ceramic or similar material, all the pans on the hob surface are electrically connected together and to earthed metal.

A test voltage of 1 000 V is then applied between live parts and the pans.

If there is no earthed metal between live parts and the surface of glass-ceramic or similar material, all the pans on the hob surface are electrically connected together, but not connected to earthed metal.

A test voltage of 3 000 V is then applied between live parts and the pans.

NOTE 101 Care is taken to ensure that the voltage applied does not overstress the other insulations.

14 Transient overvoltages

This clause of Part 1 is applicable.

15 Moisture resistance

This clause of Part 1 is applicable except as follows.

15.1.1 Addition:

In addition, IPX0, IPX1, IPX2, IPX3 and IPX4 appliances are subjected for 5 min to the following splash test.

The apparatus shown in Figure 103 is used. During the test, the water pressure is so regulated that the water splashes up 150 mm above the bottom of the bowl. The bowl is placed on the floor for appliances normally used on the floor. For all other appliances on a horizontal support 50 mm below the lowest edge of the appliance, the bowl is moved around

in such a way as to splash the appliance from all directions. Care is taken that the appliance is not hit by the direct jet.

15.1.2 Modification:

Appliances normally used on a table are placed on a support having dimensions that are 15 cm ± 5 cm in excess of those of the orthogonal projection of the appliance on the support.

Addition:

If detailed instructions regarding the cleaning of movable but non-detachable (for example hinged) hob elements are given in the instruction sheet, tests on these hob elements are carried out with the elements in the horizontal position of normal use.

15.2 Addition:

Appliances are positioned so that the hob surface is horizontal and if the hob elements are adjustable separately, their surfaces are also horizontal.

A vessel having a diameter equal to or not more than 25 mm smaller than the largest inscribed circle on the hob element or cooking zone is completely filled with the solution and placed in the most unfavourable position, not overlapping the hob element or the cooking zone.

A further quantity of the solution equal to approximately 2 l is poured steadily into the vessel over a period of 1 min.

The test is made on each hob element separately, the tray or other receptacle being emptied each time.

For appliances incorporating ovens or grills, the spillage test is made by pouring steadily over a period of 1 min approximately 1 l of the solution over the bottom surface of the oven or grilling compartment.

For appliances incorporating griddle plates, approximately 1 l of the solution is poured steadily over a period of 1 min onto the centre of the surface of the griddle plate.

If controls are mounted in the hob surface of the appliance 1 l of the solution is poured.

15.101 Appliances that are provided with a tap intended for filling or cleaning, shall be constructed so that the water from the tap cannot come into contact with **live parts**.

Compliance is checked by the following test.

The tap is fully opened for 1 min with the appliance connected to a water supply having the maximum water pressure indicated by the manufacturer. Tiltable and movable parts, including lids, are tilted or placed in the most unfavourable positions. Swivelling outlets of water taps are positioned so as to direct water onto those parts that will give the most unfavourable result. Immediately following this treatment the appliance shall withstand an electric strength test as specified in 16.3.

16 Leakage current and electric strength

This clause of Part 1 is applicable except as follows.

16.1 Addition:

For appliances provided with hob surfaces of glass-ceramic or similar material, the tests of 16.2 and 16.3 are made with a pan or pans as described in 3.1.9.

If more than one pan is placed on a single cooking zone, they are electrically connected together.

16.2 Modification:

Instead of the permissible leakage current for stationary class I appliances, the following applies:

- for cord and plug connected appliances 0,75 mA or 1 mA per kW **rated power input** of the appliance with a maximum of 10 mA, whichever is higher.*
- for other appliances 0,75 mA or 1 mA per kW **rated power input** of the appliance with no maximum, whichever is higher.*

For portable class I appliances, instead of the permissible leakage current, the following applies:

- for cord and plug connected appliances 0,75 mA or 1 mA per kW **rated power input** of the appliance with a maximum of 10 mA, whichever is higher.*

Addition:

If there is earthed metal between live parts and the surface of glass-ceramic or similar material, the leakage current is measured for each of the cooking zones in turn, only the pan(s) concerned being connected to earthed metal.

The leakage current shall not exceed 1 mA per kW of the power input of the heating unit being tested.

If there is no earthed metal between live parts and the surface of glass-ceramic or similar material, the leakage current is measured between live parts and the pan(s) for each of the cooking zones in turn, the pan(s) concerned not being connected to earthed metal.

In addition, the leakage current is measured between live parts and a probe consisting of a flat metal disc 50 mm in diameter. The probe is placed in all positions on the hob surface outside the cooking zones, the pans remaining in position.

For each measurement, the leakage current shall not exceed 0,25 mA.

16.3 Addition:

If there is earthed metal between live parts and the surface of glass-ceramic or similar material, all the pans on the hob surface are electrically connected together and to the earthed metal.

A test voltage of 1 250 V is then applied between live parts and the pans.

If there is no earthed metal between live parts and the surface of glass-ceramic or similar material, all the pans on the hob surface are electrically connected together, but not connected to earthed metal.

A test voltage of 3 000 V is then applied between live parts and the pans.

17 Overload protection of transformers and associated circuits

This clause of Part 1 is applicable.

18 Endurance

This clause of Part 1 is applicable except as follows.

18.101 Appliances incorporating **induction heating sources** shall be constructed so that, in normal use, there is no failure that impairs compliance with this standard. The insulation shall not be damaged and connections shall not work loose.

Compliance is checked by energizing each induction heating source 100 000 times by moving the smallest pan recommended by the manufacturer (or an equivalent metallic object) on and off the hob element at a rate of six times per minute (5 s for each movement). The test is made at the least favourable voltage as determined in Clause 11.

18.102 Appliances incorporating surfaces of glass-ceramic or similar material shall withstand thermal stresses liable to occur in normal use.

Compliance is checked by the following test:

The appliance is operated with all heating sources beneath the glass-ceramic or similar material energized at the same time. Non-induction heating sources are operated with a pan filled with water according to 3.1.9 but placed in the most unfavourable position on the cooking zone. Induction heating sources are operated with an empty pan.

The controls are set at maximum and the appliance is operated for 500 cycles, each cycle comprising 10 min on and 20 min off, the supply being 1,1 times rated voltage. The operation of thermostats or temperature limiters during the test is ignored.

*Immediately after the last energized period the pan(s) is (are) removed and the **hob surface** is subjected to a spillage test using $2^{+0,1}_0$ l of cold water between 10 °C and 15 °C, poured steadily over the surface for 1 min.*

Fifteen minutes later, all excess water is removed from the surface.

After the test, the surface shall not be cracked or broken and the appliance shall withstand the test in 16.3.

19 Abnormal operation

This clause of Part 1 is applicable except as follows.

19.1 Modification:

Instead of the first paragraph of the test specification, the following applies.

All appliances are subjected to the tests of 19.2 and 19.3.

In addition, appliances provided with a control limiting the temperature during the tests of Clause 11 are subjected to the test of 19.4 and, where applicable, to the test of 19.5. However, for these tests, hob elements with induction heating sources are not energized and appliances incorporating only induction heating sources are not tested.

Appliances incorporating PTC heating elements are also subjected to the test of 19.6.

19.2 Addition:

Induction heating sources beneath a flat surface of glass-ceramic or similar material are operated with a 6 mm thick disc made of grey cast iron Class 250 in accordance with ISO 185. The diameter of the disc shall be in accordance with the pans specified in 3.1.9. For other than flat surfaces (for example a wok) the supplied pan or a pan recommended by the manufacturer shall be used. The disc is placed on the centre of the cooking zone. The induction heating sources are supplied with a voltage of 0,94 times the rated voltage. The maximum concavity of the base of the disc is $0 < c < d/100$ (see Figure 104). The base of the disc shall not be convex.

Non-induction heating sources beneath a surface of glass-ceramic or similar material are operated without a pan or with an empty pan, whichever is the least favourable condition.

For all heating units, the controls are adjusted to the highest setting.

Pan detectors are rendered inoperative.

19.3 Modification:

Induction heating sources are supplied with a voltage of 1,06 times the rated voltage.

If more than one hob element with a non-induction heating source is incorporated in an appliance, the supply voltage is that required to provide a power input of 1,15 times the rated power input under normal operation.

19.11.2 Addition:

During simulation of the fault conditions, it shall be possible to switch off any energized hob element.

The fault conditions are also simulated with all hob elements switched off, the appliance being supplied at rated voltage. If a pan detector is incorporated, a suitable vessel is placed on the cooking zone.

The hob elements shall not become energized.

19.12 Addition:

The test is also repeated if, for any of the fault conditions specified in 19.101, the safety of the appliance depends on the operation of a miniature fuse-link complying with IEC 60127.

19.13 Addition:

If the temperature rise of the walls above and below the hob surface exceeds 125 K, the requirements of 7.101 apply.

The temperature of the windings of induction coils shall not exceed the values shown in Table 8 of 19.7.

The electric strength test of induction heating sources is carried out immediately after switching off the appliance.

19.101 Appliances incorporating **induction heating sources** shall be constructed so that the risk of fire, mechanical hazard or electric shock is obviated as far as is practicable in the event of incorrect operation or the development of defects in control devices or circuit components.

Compliance is checked by applying any form of operation or any defect in the relevant circuits that may be expected in normal use while the appliance is operated under conditions of normal operation at rated voltage or at the upper limit of the rated voltage range. Only one fault condition is reproduced at a time, the tests being made consecutively.

NOTE Examples of fault conditions are:

- drop-out of contactors and of electromagnetic components;
- failure of motors to start;
- drop in voltage supply, re-appearance of the voltage, voltage interruptions of up to 0,5 s;
- fault conditions specified in 19.11 as applicable.

Examination of the appliance and its circuit diagrams will generally show the fault conditions to be simulated.

20 Stability and mechanical hazards

This clause of Part 1 is applicable except as follows.

20.101 Appliances other than appliances intended to be fixed to the floor shall have adequate stability when the doors are open and subjected to a load.

Compliance is checked by the following tests.

Doors having a horizontal hinge at their lower edge are opened and a weight is gently placed on the surface of the door so that its centre of gravity is vertically over the geometric centre of the door. The contact area of the weight is such as will cause no damage to the door, and its mass is

- *for appliances normally used on a floor:*
 - *for oven doors: 23 kg or such higher value as, according to the manufacturer's cooking instructions, can be placed in the oven;*
 - *for other doors: 7 kg;*
- *for appliances normally used on a table or similar support and provided with doors having a horizontal hinge at their lower edge and a projection of at least 225 mm from the hinge to the opening edge:*
 - *7 kg or such higher value as, according to the manufacturer's cooking instructions, can be placed in the oven.*

Doors, except those where the lower level of the oven is above a hob, having a vertical hinge are opened through an angle of 90°, and a downward force of 140 N is then applied gently to the top of the door at the extremity furthest from the hinge.

This test is repeated with the door opened as far as possible, but not through an angle of more than 180°.

During these tests, the appliance shall not tilt.

For the weight, a sandbag may be used.

For appliances provided with more than one door, the tests are made on each door separately.

For non-rectangular doors, the force is applied to that point furthest from the hinge where such a force might be exerted in normal use.

Damage to, and deformation of, doors and hinges are neglected.

21 Mechanical strength

This clause of Part 1 is applicable except as follows.

21.101 Shelves shall be constructed so that they do not fall away from the shelf supports either when inside the oven or extended out by 50 % of their depth. They shall not tip when extended out by 50 %.

Compliance is checked by the following test.

Load a cake tin or similar container, having an area of 75 % of that of the shelf, with evenly distributed weights of mass totalled 40 kg for each square meter of tin area. Insert a shelf, with the loaded tin centrally disposed, on the supports provided in the oven. Move the shelf as far as possible to the left, leave for 1 min and then withdraw it. Re-insert the shelf and move it to the extreme right, leave it for 1 min and again withdraw it.

During this test the shelf shall not fall away from the support.

The test is then repeated with the shelf extended out by 50 % of its depth. Then apply an additional force of 10 N vertically downward on the centre of the exposed front edge of the shelf. During this test the shelf shall not tip.

NOTE A small angle of deflection is allowed.

21.102 Hob surfaces of glass-ceramic or similar material shall withstand the stresses liable to occur in normal use.

Compliance is checked by the following test.

Heating sources beneath a surface of glass-ceramic or similar material are operated in accordance with the conditions of Clause 11 until steady conditions are established. After switching off, the hob surface is immediately subjected to the following test:

A vessel having a copper or aluminium base that is flat over a diameter of 220 mm ± 10 mm with edges rounded with a radius of at least 10 mm is uniformly filled with sand or shot so that the total mass is 4 kg. The vessel is dropped flat from a height of 150 mm onto the surface.

The test is carried out 10 times on any part of the hob surface but not within 20 mm of control knobs.

The heating sources are then again operated in accordance with the conditions of Clause 11 until steady conditions are established.

Immediately after switching off, a quantity of $2^{+0,1}_0$ l of cold water at 15 °C ± 5 °C is then poured steadily over a period of 1 min over the surface; 15 min later all excess water is removed. The appliance is then allowed to cool to approximately ambient temperature. An additional quantity of $2^{+0,1}_0$ l of cold water is then again poured steadily over a period of 1 min over the surface.

Fifteen minutes later all excess water is removed and the surface wiped dry.

After the tests the surface shall not be cracked or broken and the appliance shall withstand the test of 16.3.

22 Construction

This clause of Part 1 is applicable except as follows.

22.54 Not applicable.

22.55 Not applicable.

22.101 For three-phase appliances, **thermal cut-outs** protecting circuits with heating elements other than those for **hob elements**, and those for motors of which the unexpected starting may cause a hazard, shall be of the non-self-resetting and trip-free type, and shall provide **all-pole disconnection** from related supply circuits.

For single-phase appliances and for single-phase heating elements and/or motors connected between one phase and neutral or between phase and phase, **thermal cut-outs** protecting circuits with heating elements other than those for **hob elements**, and those for motors of which the unexpected starting may cause a hazard, shall be of the non-self-resetting and trip-free type, and shall provide at least one-pole disconnection.

If the **non-self-resetting thermal cut-out** is only accessible after removing parts with the aid of a **tool**, the trip-free type is not required.

NOTE **Thermal cut-outs** of the trip-free type have an automatic action, with a reset actuating member, so constructed that the automatic action is independent of manipulation or position of the reset mechanism.

Thermal cut-outs of the bulb and capillary type that operate during the tests of Clause 19 shall be such that rupture of the capillary tube shall not impair compliance with the requirements of 19.13.

Compliance is checked by inspection, by manual test and by rupturing the capillary tube.

Care shall be taken to ensure that the rupture does not seal the capillary tube.

22.102 Lights, switches or push-buttons shall only be coloured red for the indication of danger, alarm or similar situations.

Compliance is checked by inspection.

22.103 Hinged lids shall be protected against accidental falling.

Compliance is checked by inspection and manual test.

22.104 Detachable hob elements and their supports shall be constructed so that the **hob elements** are prevented from rotating about a vertical axis and are adequately supported in all possible positions of adjustment of the supports.

Hinged **hob elements** shall be protected against accidental dropping. This requirement does not apply to hinged **hob elements** that can be opened through an angle of at least 100°.

Compliance is checked by applying a force of 20 N in the least favourable position and direction to the raised hob element. The hob element shall not rotate or fall back to its operating position.

22.105 In addition to the position of control knobs, if any, **induction heating sources** shall have adequate visual or audible warning that the control is in the "ON" position.

Compliance is checked by inspection.

22.106 Appliances incorporating **induction heating sources** shall be constructed so that the power input of these sources is limited to a value of 120 % of the marked or declared power input.

Compliance is checked by inspection and measurement.

22.107 Portable appliances shall not have openings on the underside that would allow small items to penetrate and touch **live parts**.

Compliance is checked by inspection and by measuring the distance between the supporting surface and live parts through openings. This distance shall be at least 6 mm. However, if the appliance is fitted with legs, this distance is increased to 10 mm if the appliance is intended to stand on the table and to 20 mm if it is intended to stand on the floor.

22.108 Hob elements with induction heating sources shall be constructed so that the **hob element** does not operate when only a small metal object is placed on the **cooking zone**.

Compliance is checked by the following test.

A disc of low carbon sheet steel 1,5 mm thick and having a diameter of 50 mm is placed flat in the most unfavourable position on the cooking zone. The controls are at their highest setting.

The temperature rise of the disc shall not exceed 35 K.

22.109 In appliances incorporating a **pan detector**, a signal lamp shall indicate when the control for the **hob element** is not switched to the **off position**.

Compliance is checked by inspection.

23 Internal wiring

This clause of Part 1 is applicable except as follows.

23.3 Addition:

When the capillary tube of a thermostat is fitted as part of the internal wiring where flexing occurs in normal use, Part 1 applies. In this case if a rupture of the capillary tube occurs the appliance shall be rendered inoperative (fail-safe).

Other capillary tubes of thermostats where flexing occurs in normal use are subjected to 1 000 flexings at a rate not exceeding 30/min. In this case the capillary tube shall show no sign of damage impairing the thermostat's further use.

24 Components

This clause of Part 1 is applicable except as follows.

24.1.4 Modification:

- *energy regulators*
 - *for automatic action* 100 000
 - *for manual action* 10 000
- *self-resetting thermal cut-outs*
 - *for radiant heating elements of glass-ceramic hobs* 100 000
 - *for other heating elements* 10 000

25 Supply connection and external flexible cords

This clause of Part 1 is applicable except as follows.

25.1 Addition:

Appliances shall not be provided with an appliance inlet.

25.3 Addition:

Appliances with a mass greater than 40 kg, intended for permanent connection to fixed wiring and not provided with rollers, castors or similar means shall be constructed so that the connection can be done after the appliance has been installed in accordance with the manufacturer's instructions.

25.7 Modification:

Supply cords shall be oil-resistant, sheathed cords. Their properties shall be at least those of ordinary polychloroprene sheathed cords (code designation 60245 IEC 57).

26 Terminals for external conductors

This clause of Part 1 is applicable.

27 Provision for earthing

This clause of Part 1 is applicable except as follows.

27.2 Addition:

Stationary appliances shall be provided with a terminal for the connection of an external equipotential conductor. This terminal shall be in effective electrical contact with all fixed exposed metal parts of the appliance, and shall allow the connection of a conductor having a nominal cross-sectional area of up to 10 mm². It shall be located in a position convenient for the connection of the bonding conductor after installation of the appliance.

NOTE 101 Small fixed exposed metal parts, for example nameplates and the like, are not required to be in electrical contact with the terminal.

28 Screws and connections

This clause of Part 1 is applicable except as follows.

28.1 Addition:

Screws made of carbon steel and alloy steel shall be made in accordance with ISO 898-1.

Screws made of corrosion-resistant stainless-steel shall be made in accordance with ISO 3506-1, or ISO 3506-2, or ISO 3506-3, or ISO 3506-4.

28.4 Addition:

Screws that make mechanical connections and electrical connections shall be so designed that the contact pressure does not change appreciably through loosening of the screwed assembly parts during operational stress and contact corrosion.

Screws that make mechanical connections and provide earthing continuity shall be so designed that the contact pressure does not change appreciably through loosening of the screwed assembly parts due to operational stress and contact corrosion. They shall be designed so that a minimum contact pressure remains.

Compliance is checked by inspection and by measuring the assembling torques for screwed connections providing earthing continuity by applying a torque as specified in Table 102 to turn the screw in the fastening direction. The screw shall not turn.

The screw shall not have been unfastened prior to performing this test.

Table 102 – Assembling torques for screwed connections providing earthing continuity

Outer thread diameter of the screw mm	Assembling torque Nm	
	Screwed connections for the mechanical strength of the screws A2-70 according to ISO 3506-1, or ISO 3506-2, or ISO 3506-3, or ISO 3506-4 and 5.8 according to ISO 898-1	Screwed connections for the mechanical strength of the screws > 8.8 according to ISO 898-1
> 2,8 and ≤ 3,6	0,8	1,3
> 3,6 and ≤ 4,2	1,9	3,0
> 4,2 and ≤ 5,3	3,7	6,0
> 5,3 and ≤ 6,3	6,5	10,0
M 8	15,0	25,0
M 10	31,0	50,0

29 Clearances, creepage distances and solid insulation

This clause of Part 1 is applicable except as follows.

29.2 Addition:

The microenvironment is pollution degree 3 and the insulation shall have a comparative tracking index (CTI) not less than 250, unless the insulation is enclosed or located so that it is unlikely to be exposed to pollution during normal use of the appliance.

30 Resistance to heat and fire

This clause of Part 1 is applicable except as follows.

30.2.1 Modification:

The glow-wire test is carried out at 650 °C. The glow-wire flammability index (GWFI) according to IEC 60695-2-12 shall be at least 650 °C.

30.2.2 Not applicable.

30.101 Filters, if any, of non-metallic materials intended for the absorption of grease are subjected to the burning test specified in ISO 9772 for category HBF material, if relevant, or shall be classified at least HB40 according to IEC 60695-11-10, except that the thickness of the specimen is the same as that in the appliance.

NOTE It may be necessary to support the specimen.

Compliance is checked by the tests of ISO 9772 or IEC 60695-11-10.

31 Resistance to rusting

This clause of Part 1 is applicable.

32 Radiation, toxicity and similar hazards

This clause of Part 1 is applicable.

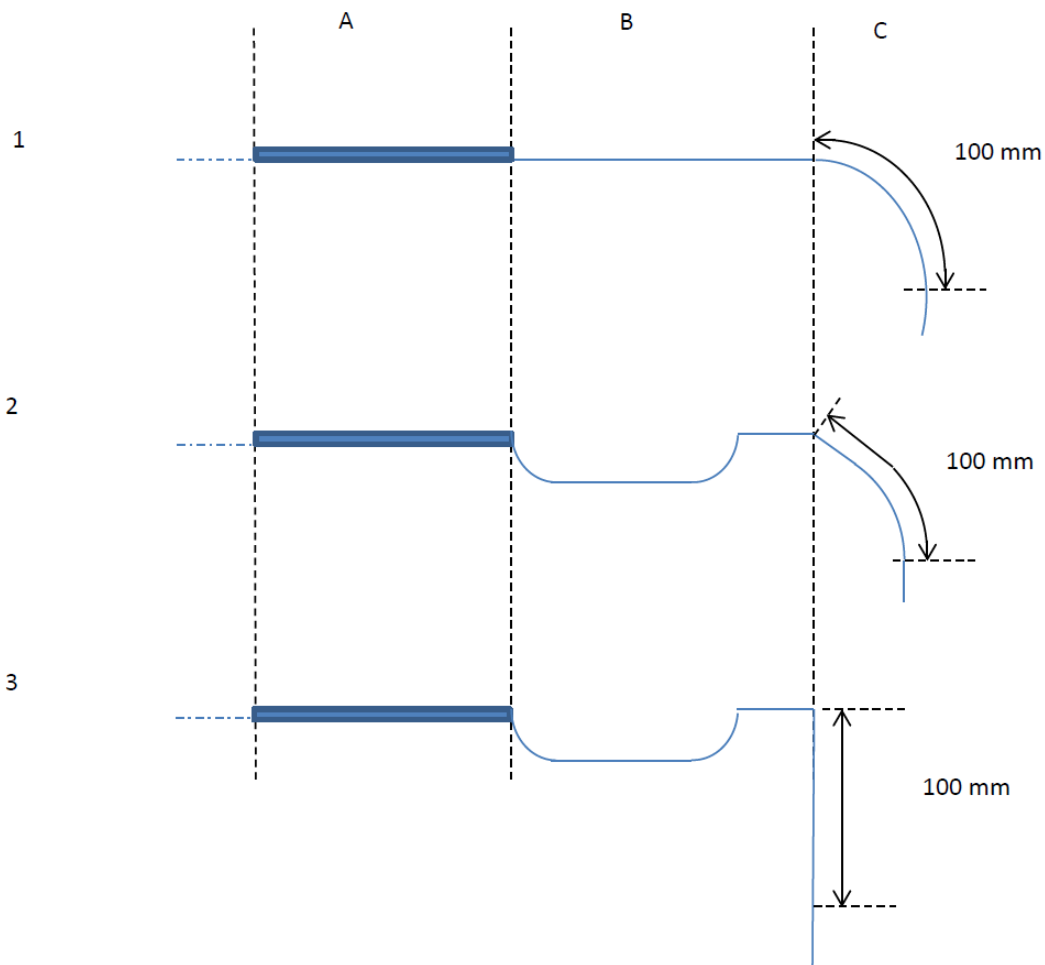

Key
A functional surface
B adjacent surface

C external accessible surface

Figure 101 – Identification of surfaces for temperature measurement

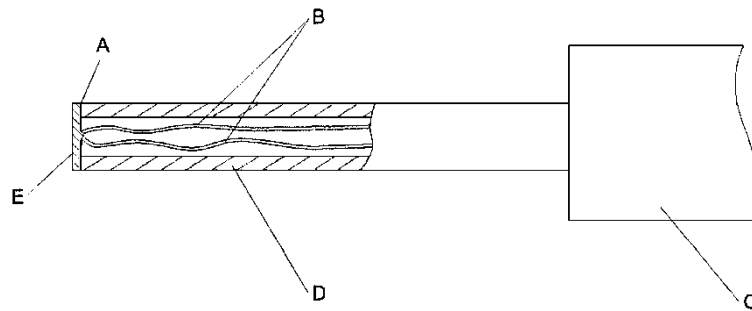

Key

- A adhesive
- B thermocouple wires 0,3 mm diameter to IEC 60584-1 Type K (chrome alumel)
- C handle arrangement permitting a contact force of $4\text{ N} \pm 1\text{ N}$
- D polycarbonate tube: inside diameter 3 mm, outside diameter 5 mm
- E tinned copper disc: 5 mm diameter, 0,5 mm thick with flat contact face

Figure 102 – Probe for measuring surface temperatures

Dimensions in millimetres

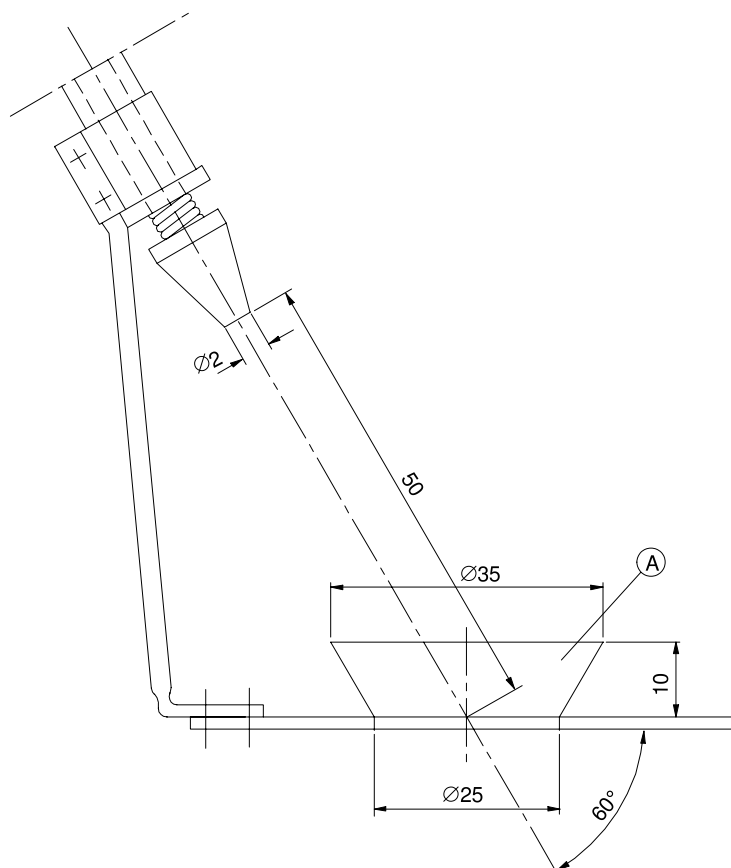

IEC 2717/02

Key

- A bowl

Figure 103 – Splash apparatus

Dimensions in millimetres (uncertainty $\pm 0,5$ mm)

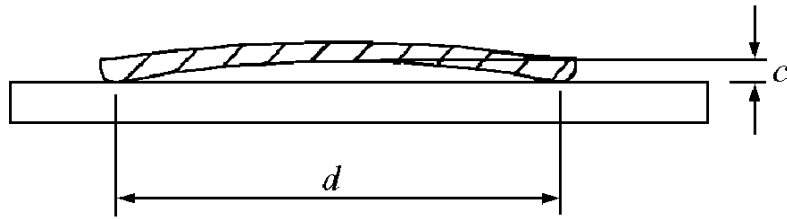

Key

c maximum concavity

d diameter of the flat area of the base

Figure 104 – Concavity of disc

Annexes

The annexes of Part 1 are applicable except as follows.

Annex N
(normative)

Proof tracking test

10.1 *Addition:*

If appropriate the proof tracking voltage is 250 V.

Annex P (informative)

Guidance for the application of this standard to appliances used in tropical climates

13 Leakage current and electric strength at operating temperature

13.2 Modification:

Instead of the permissible leakage current for stationary class I appliances, the following applies:

- *for cord and plug connected appliances* *0,5 mA or 0,5 mA per kW **rated power input** of the appliance with a maximum of 5 mA.*
- *for other appliances* *0,5 mA or 0,5 mA per kW **rated power input** of the appliance with no maximum.*

For portable class I appliances, instead of the permissible leakage current, the following applies:

- *for cord and plug connected appliances* *0,5 mA or 0,5 mA per kW **rated power input** of the appliance with a maximum of 5 mA, whichever is higher.*

16 Leakage current and electric strength

16.2 Modification:

Instead of the permissible leakage current for stationary class I appliances, the following applies:

- *for cord and plug connected appliances* *0,5 mA or 0,5 mA per kW **rated power input** of the appliance with a maximum of 5 mA.*
- *for other appliances* *0,5 mA or 0,5 mA per kW **rated power input** of the appliance with no maximum.*

For portable class I appliances, instead of the permissible leakage current, the following applies:

- *for cord and plug connected appliances* *0,5 mA or 0,5 mA per kW **rated power input** of the appliance with a maximum of 5 mA, whichever is higher.*

Bibliography

The bibliography of Part 1 is applicable except as follows.

Addition:

IEC 60335-2-42, Household and similar electrical appliances – Safety – Part 2-42: Particular requirements for commercial electric forced convection ovens, steam cookers and steam-convection ovens

IEC 60335-2-49, Household and similar electrical appliances – Safety – Part 2-49: Particular requirements for commercial electric hot cupboards

IEC 60335-2-90, Household and similar electrical appliances – Safety – Part 2-90: Particular requirements for commercial microwave ovens

INTERNATIONAL
ELECTROTECHNICAL
COMMISSION

3, rue de Varembé
PO Box 131
CH-1211 Geneva 20
Switzerland

Tel: + 41 22 919 02 11
Fax: + 41 22 919 03 00
info@iec.ch
www.iec.ch