



Designation: E299 – 17a

## Standard Test Method for Trace Amounts of Peroxides In Organic Solvents<sup>1</sup>

This standard is issued under the fixed designation E299; the number immediately following the designation indicates the year of original adoption or, in the case of revision, the year of last revision. A number in parentheses indicates the year of last reapproval. A superscript epsilon ( $\epsilon$ ) indicates an editorial change since the last revision or reapproval.

*This standard has been approved for use by agencies of the U.S. Department of Defense.*

### 1. Scope\*

1.1 This test method<sup>2,3</sup> covers organic solvents containing active oxygen in the range from 5 to 80  $\mu\text{g/g}$  (ppm) or higher. By using a special reaction-absorption cell, the test method can be extended to cover the range from 0 to 5 ppm. The test method can be used to determine numerous peroxide classes of varying reactivity such as hydroperoxides, diacyl peroxides, diaroyl peroxides, peresters, and ketone peroxides. The stable di-*tert*-alkyl peroxides do not react under the conditions of analysis.

1.2 Solvents that can be analyzed successfully include saturated and aromatic hydrocarbons, alcohols, ethers, ketones, and esters. In addition, the test method is applicable to olefinic solvents and to certain compounds that contain  $\alpha$ ,  $\beta$ , and conjugated unsaturation. Solid samples that are soluble in the acetic acid-chloroform solvent also can be analyzed.

1.3 Review the current Safety Data Sheets (SDS) for detailed information concerning toxicity, first aid practices, and safety precautions.

1.4 The values stated in SI units are to be regarded as standard. The values given in parentheses are for information only.

1.5 *This standard does not purport to address the safety concerns, if any, associated with its use. It is the responsibility of the user of this standard to establish appropriate safety and health practices and determine the applicability of regulatory limitations prior to use.*

1.6 *This international standard was developed in accordance with internationally recognized principles on standardization established in the Decision on Principles for the Development of International Standards, Guides and Recom-*

*mendations issued by the World Trade Organization Technical Barriers to Trade (TBT) Committee.*

### 2. Referenced Documents

2.1 *ASTM Standards:*<sup>4</sup>

[D1193 Specification for Reagent Water](#)

[D6809 Guide for Quality Control and Quality Assurance Procedures for Aromatic Hydrocarbons and Related Materials](#)

[E180 Practice for Determining the Precision of ASTM Methods for Analysis and Testing of Industrial and Specialty Chemicals \(Withdrawn 2009\)](#)<sup>5</sup>

### 3. Summary of Test Method

3.1 A sample is dissolved in a mixture of acetic acid and chloroform. The solution is deaerated and potassium iodide reagent solution is added. The mixture is allowed to react in the dark for 1 h, thereby releasing an equivalent amount of iodine. The absorbance of the solution is measured at 470 nm and the amount of active oxygen present in the sample is determined by reference to a calibration curve prepared from iodine.

3.2 For samples containing 0 to 5  $\mu\text{g/g}$  (ppm) active oxygen, a special reaction-absorption cell is employed. The sample is de-aerated and the reaction is carried out within the cell. Absorbance measurements are made at 410 nm to increase the sensitivity.

### 4. Significance and Use

4.1 Dilute solutions of peroxides in various organic solvents frequently are used as catalysts or reaction initiators. Peroxides also can be formed through autoxidation in certain classes of compounds including ethers, acetals, dienes, and alkylaromatic hydrocarbons and present a potential safety hazard. This test method provides a procedure for determining the peroxide or active oxygen level.

<sup>1</sup> This test method is under the jurisdiction of ASTM Committee D16 on Aromatic, Industrial, Specialty and Related Chemicals and is the direct responsibility of Subcommittee D16.15 on Industrial and Specialty General Standards.

Current edition approved July 1, 2017. Published July 2017. Originally approved in 1966. Last previous edition approved in 2017 as E299 – 17. DOI: 10.1520/E0299-17a.

<sup>2</sup> Banerjee, D. K., and Budke, C. C., *Analytical Chemistry*, ANCHAM, Vol 36, 1964, pp. 792–796.

<sup>3</sup> Banerjee, D. K., and Budke, C. C., *Analytical Chemistry*, ANCHAM, Vol 36, 1964, pp. 2367–2368.

<sup>4</sup> For referenced ASTM standards, visit the ASTM website, [www.astm.org](http://www.astm.org), or contact ASTM Customer Service at [service@astm.org](mailto:service@astm.org). For *Annual Book of ASTM Standards* volume information, refer to the standard's Document Summary page on the ASTM website.

<sup>5</sup> The last approved version of this historical standard is referenced on [www.astm.org](http://www.astm.org).

\*A Summary of Changes section appears at the end of this standard

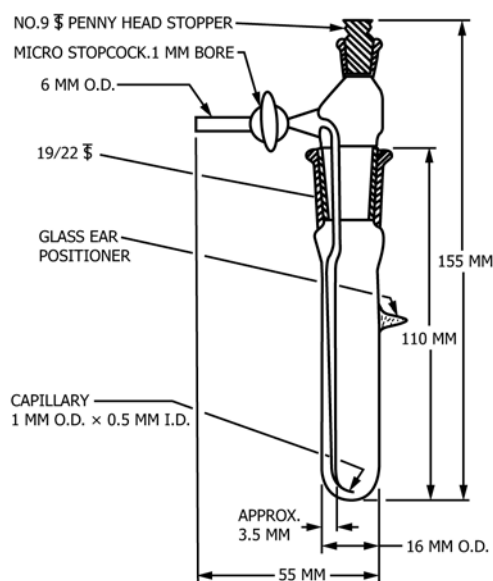

FIG. 1 Absorption Cell for Low-Active Oxygen

## 5. Interferences

5.1 Oxidizing or reducing substances present in the sample will interfere. Colored solutions can be analyzed if an absorbance correction is made.

## 6. Apparatus

6.1 *Spectrophotometer*—Beckman Model DU or equivalent with matched 1-cm cells.

6.2 *Special Reaction-Absorption Cell* (Fig. 1)—When this cell is used, the regular Beckman cell carriage shall be replaced with the attachment provided for measuring the absorbance in test tubes.

## 7. Reagents

7.1 *Purity of Reagents*—Reagent grade chemicals shall be used in all tests. Unless otherwise indicated, it is intended that all reagents shall conform to the specifications of the Committee on Analytical Reagents of the American Chemical Society, where such specifications are available.<sup>6</sup> Other grades may be used, provided it is first ascertained that the reagent is of sufficiently high purity to permit its use without lessening the accuracy of the determination.

7.2 *Purity of Water*—Unless otherwise indicated, references to water shall be understood to mean Type II or Type III reagent water conforming to Specification D1193.

7.3 *Acetic Acid-Chloroform Solvent (2 + 1)*—Mix 2 volumes of acetic acid with 1 volume of chloroform.

<sup>6</sup> *Reagent Chemicals, American Chemical Society Specifications*, American Chemical Society, Washington, DC. For suggestions on the testing of reagents not listed by the American Chemical Society, see *Analar Standards for Laboratory Chemicals*, BDH Ltd., Poole, Dorset, U.K., and the *United States Pharmacopeia and National Formulary*, U.S. Pharmacopeial Convention, Inc. (USPC), Rockville, MD.

7.4 *Acetic Acid-Chloroform Solvent (Containing Approximately 4 % Water)*—Add 40 mL of water to 1 L of solvent prepared as described in 7.3.

7.5 *Iodine*.

7.6 *Nitrogen Cylinder*.

7.7 *Potassium Iodide Solution (50 %)*—Dissolve 20 g of potassium iodide (KI) in 20 mL of de-aerated water. This reagent should be freshly prepared just prior to use.

7.8 *Water, De-aerated*—Pass nitrogen through distilled water for several minutes prior to use.

## 8. Procedure

8.1 *High Range—0 to 400 µg of Active Oxygen:*

8.1.1 *Preparation of Calibration Curve:*

8.1.1.1 Dissolve 0.1270 g of iodine in acetic acid-chloroform solvent (2 + 1) and dilute to 100 mL in a volumetric flask. This solution contains 1.27 mg of iodine/mL, which is equivalent to 80.0 µg of active oxygen/mL.

8.1.1.2 Transfer 0, 1, 2, 3, 4, and 5-mL aliquots of this solution to 25-mL volumetric flasks and dilute each to volume with the acetic acid-chloroform solvent. Mix thoroughly.

8.1.1.3 Using a hypodermic needle or glass capillary, sparge the solution with nitrogen for 1 to 1.5 min, add 1 mL of freshly prepared KI solution, and continue the nitrogen flow for 1 min. Stopper and mix well.

8.1.1.4 Measure the absorbance of each solution at 470 nm, using 1-cm cells and a water reference.

8.1.1.5 Subtract the absorbance of the blank and plot the absorbance of each standard against micrograms of active oxygen per 25 mL.

8.1.2 *Analysis of Sample:*

8.1.2.1 Transfer a sample containing up to 400 µg of active oxygen to a 25-mL volumetric flask and dilute to volume with acetic acid-chloroform solvent (2 + 1) (Note 1). Mix thoroughly.

NOTE 1—A sample volume up to 15 mL may be used provided it is miscible with the amount of acetic acid-chloroform solvent required to dilute the sample to 25 mL.

8.1.2.2 Sparge the solution with nitrogen for 1 to 1.5 min, add 1 mL of freshly prepared KI solution, and continue the nitrogen flow for an additional 1 min.

8.1.2.3 Stopper, mix well, and allow the solution to stand in the dark for 1 h.

NOTE 2—Very reactive peroxides react within less than 10 min, while less reactive peroxides require up to 1 h for complete reaction. A general reaction time for 1 h is therefore specified.

8.1.2.4 Measure the absorbance of the solution at 470 nm using 1-cm cells and a water reference.

NOTE 3—Depending on the amount and type of sample present, some precipitation of KI may occur. However, the KI crystals readily settle to the bottom in absorbance measurement.

8.1.2.5 Subtract the absorbance of a blank carried through the entire procedure, and obtain the micrograms of active oxygen present in the sample by reference to the calibration curve.

8.2 *Low Range—0 to 40 µg of Active Oxygen:*

### 8.2.1 Preparation of Calibration Curve:

8.2.1.1 Dissolve 0.0634 g of iodine in acetic acid-chloroform solvent (2 + 1) and dilute to 100 mL. Transfer a 10-mL aliquot to another 100-mL volumetric flask and dilute to volume with acetic acid-chloroform solvent. This solution contains 63.4 µg of iodine/mL which is equivalent to 4.0 µg of active oxygen/mL.

8.2.1.2 Transfer 0, 1, 3, 5, 8, and 10-mL aliquots to 25-mL volumetric flasks and dilute to volume with the acetic acid-chloroform solvent containing 4 % water. Mix well.

8.2.1.3 Transfer a portion of each standard to the special absorption cell (Fig. 1). Admit a flow of nitrogen through the side arm and purge the solution for 3 min.

8.2.1.4 Add 5 drops of freshly prepared de-aerated KI solution and replace the stopper loosely. Continue purging with nitrogen for an additional 3 min.

8.2.1.5 Tighten the stopper and close the stopcock on the inlet tube so that the solution is under a slightly positive nitrogen pressure.

8.2.1.6 The absorption tubes shall be matched and provided with a glass ear for reproducible positioning before absorbance measurements are made. Insert the tube into the cell carriage and rotate until the glass ear contacts the side of the tube holder. Measure the absorbance of the solution at 410 nm against water contained in another matched absorption tube.

8.2.1.7 Subtract the absorbance of the blank and plot absorbance against micrograms of active oxygen per 25 mL.

### 8.2.2 Analysis of Sample:

8.2.2.1 Transfer a 5.00-mL sample to a 25-mL volumetric flask and dilute to volume with acetic acid-chloroform solvent (2 + 1) containing 4 % water. Mix well.

8.2.2.2 Transfer a portion of the solution to the special absorption cell and develop the color as described in 8.2.1.3, 8.2.1.4, and 8.2.1.5.

8.2.2.3 Allow the sample to stand in the dark for 1 h.

8.2.2.4 Measure the absorbance of the solution at 410 nm against water contained in the other matched absorption tube.

8.2.2.5 Subtract the absorbance obtained for a blank carried through the entire procedure, and obtain the micrograms of active oxygen present in the sample by reference to the calibration curve.

## 9. Calculation

9.1 Calculate the active oxygen content of the sample as follows:

$$\text{active oxygen, } \mu\text{g/g (ppm)} = \frac{A}{BC} \quad (1)$$

where:

*A* = active oxygen found, µg,

*B* = sample used, mL, and

*C* = density, g/mL.

9.2 If a specific peroxide is known to be present, convert the micrograms per gram (parts per million) of active oxygen to peroxide by using the appropriate conversion factor.

$$\text{Peroxide } X, \mu\text{g/g (ppm)} = \text{active oxygen in sample, } \mu\text{g/g (ppm)} \times F \quad (2)$$

where *F* = conversion factor for peroxide *X*.

9.2.1 Conversion factors for some common peroxides are as follows:

Cumene hydroperoxide	9.5125
Benzoyl peroxide	15.1400
t-butyl hydroperoxide	5.6328
Lauroyle peroxide	24.9150

## 10. Report

10.1 *High Range*—Report the concentration of the peroxide to the nearest 1 µg/g (ppm).

10.2 *Low Range*—Report the concentration of the peroxide to the nearest 0.1 µg/g (ppm).

## 11. Precision and Bias<sup>7</sup>

11.1 *Precision—High Range*—The following criteria shall be used for judging the acceptability of results (Note 4):

11.1.1 *Repeatability (Single Analyst)*—The standard deviation for a single determination has been estimated to be 0.7 µg/g (ppm) at 36 df. The 95 % limit for the difference between two such determinations is 2 µg/g (ppm).

11.1.2 *Laboratory Precision (Within-Laboratory, Between-Days Variability)*—The standard deviation of results, each the average of duplicates, obtained by the same analyst on different days, has been estimated to be 2.9 µg/g (ppm) at 14 df. The 95 % limit for the difference between two such averages is 8.1 µg/g (ppm).

11.1.3 *Reproducibility (Multilaboratory)*—The standard deviation of results, each the average of duplicates, obtained by analysts in different laboratories has been estimated to be 4.6 µg/g (ppm) at 5 df. The 95 % limit for the difference between two such averages is 13 µg/g (ppm).

NOTE 4—The above precision estimates are based on an interlaboratory study on three samples containing 30 to 90 µg/g (ppm) of active oxygen. One analyst in each of six laboratories performed duplicate determinations and repeated one day later, for a total of 72 determinations. Practice E180 was used in developing these precision estimates.

11.2 *Bias*—The bias of this test method has not been determined due to the lack of suitable reference materials or methodology.

11.3 *Precision—Low Range*—The following criteria shall be used for judging the acceptability of results (Note 5):

11.3.1 *Repeatability (Single Analyst)*—The standard deviation for a single determination has been estimated to be 0.07 µg/g (ppm) at 24 df. The 95 % limit for the difference between two such determinations is 0.2 µg/g (ppm).

11.3.2 *Laboratory Precision (Within-Laboratory, Between-Days Variability)*—The standard deviation of results, each the average of duplicates, obtained by the same analyst on different days, has been estimated to be 0.11 µg/g (ppm) at 13 df. The 95 % limit for the difference between two such averages is 0.31 µg/g (ppm).

11.3.3 *Reproducibility (Multilaboratory)*—The standard deviation of results, each the average of duplicates, obtained by

<sup>7</sup> Supporting data have been filed at ASTM International Headquarters and may be obtained by requesting Research Report RR:E15-1002. Contact ASTM Customer Service at service@astm.org.

analysts in different laboratories has been estimated to be 0.49 µg/g (ppm) at 4 df. The 95 % limit for the difference between two such averages is 1.4 µg/g (ppm).

NOTE 5—The above precision estimates are based on an interlaboratory study on three samples containing 3 to 10 µg/g (ppm) of active oxygen. One analyst in each of five laboratories performed duplicate determinations and repeated one day later, for a total of 60 determinations. Practice E180 was used in developing these precision estimates.

11.4 *Bias*—The bias of this test method has not been determined due to the lack of suitable reference materials or methodology.

## 12. Quality Guidelines

12.1 Laboratories shall have a quality control system in place.

12.1.1 Confirm the performance of the test instrument or test method by analyzing a quality control sample following the guidelines of standard statistical quality control practices.

12.1.2 A quality control sample is a stable material isolated from the production process and representative of the sample being analyzed.

12.1.3 When QA/QC protocols are already established in the testing facility, these protocols are acceptable when they confirm the validity of test results.

12.1.4 When there are no QA/QC protocols established in the testing facility, use the guidelines described in Guide D6809 or similar statistical quality control practices.

## 13. Keywords

13.1 assay; organic; peroxides; spectrophotometric

## SUMMARY OF CHANGES

Subcommittee D16.15 has identified the location of selected changes to this standard since the last issue (E299–17) that may impact the use of this standard. (Approved July 1, 2017.)

(1) Section 12 Quality Guidelines was added.

Subcommittee D16.15 has identified the location of selected changes to this standard since the last issue (E299–08) that may impact the use of this standard. (Approved February 1, 2017.)

(1) Removed “Material” from MSDS statement in Scope section 1.5.

*ASTM International takes no position respecting the validity of any patent rights asserted in connection with any item mentioned in this standard. Users of this standard are expressly advised that determination of the validity of any such patent rights, and the risk of infringement of such rights, are entirely their own responsibility.*

*This standard is subject to revision at any time by the responsible technical committee and must be reviewed every five years and if not revised, either reapproved or withdrawn. Your comments are invited either for revision of this standard or for additional standards and should be addressed to ASTM International Headquarters. Your comments will receive careful consideration at a meeting of the responsible technical committee, which you may attend. If you feel that your comments have not received a fair hearing you should make your views known to the ASTM Committee on Standards, at the address shown below.*

*This standard is copyrighted by ASTM International, 100 Barr Harbor Drive, PO Box C700, West Conshohocken, PA 19428-2959, United States. Individual reprints (single or multiple copies) of this standard may be obtained by contacting ASTM at the above address or at 610-832-9585 (phone), 610-832-9555 (fax), or service@astm.org (e-mail); or through the ASTM website (www.astm.org). Permission rights to photocopy the standard may also be secured from the Copyright Clearance Center, 222 Rosewood Drive, Danvers, MA 01923, Tel: (978) 646-2600; <http://www.copyright.com/>*