

ASME B5.55M-1994

**Specification and  
Performance Standard,  
Power Press Brakes**

AN AMERICAN NATIONAL STANDARD



The American Society of  
Mechanical Engineers

AN AMERICAN NATIONAL STANDARD

# Specification and Performance Standard, Power Press Brakes

ASME B5.55M-1994



The American Society of  
Mechanical Engineers

345 East 47th Street, New York, N.Y. 10017

Date of Issuance: December 2, 1994

This Standard will be revised when the Society approves the issuance of a new edition. There will be no addenda or written interpretations of the requirements of this Standard issued to this Edition.

ASME is the registered trademark of The American Society of Mechanical Engineers.

This code or standard was developed under procedures accredited as meeting the criteria for American National Standards. The Consensus Committee that approved the code or standard was balanced to assure that individuals from competent and concerned interests have had an opportunity to participate. The proposed code or standard was made available for public review and comment which provides an opportunity for additional public input from industry, academia, regulatory agencies, and the public-at-large.

ASME does not "approve," "rate," or "endorse" any item, construction, proprietary device, or activity.

ASME does not take any position with respect to the validity of any patent rights asserted in connection with any items mentioned in this document, and does not undertake to insure anyone utilizing a standard against liability for infringement of any applicable Letters Patent, nor assume any such liability. Users of a code or standard are expressly advised that determination of the validity of any such patent rights, and the risk of infringement of such rights, is entirely their own responsibility.

Participation by federal agency representative(s) or person(s) affiliated with industry is not to be interpreted as government or industry endorsement of this code or standard.

ASME accepts responsibility for only those interpretations issued in accordance with governing ASME procedures and policies which preclude the issuance of interpretations by individual volunteers.

No part of this document may be reproduced in any form,  
in an electronic retrieval system or otherwise,  
without the prior written permission of the publisher.

Copyright © 1994 by  
THE AMERICAN SOCIETY OF MECHANICAL ENGINEERS  
All Rights Reserved  
Printed in U.S.A.

## FOREWORD

(This Foreword is not part of ASME B5.55M-1994.)

Recognizing the need for an industry standard for power press brakes, the American Society of Mechanical Engineers Committee on Machine Tools and Components (B5) established in February 1990 a technical committee, B5 TC31, to develop the first American standard relating to this equipment. In the latter part of February 1990 an organizational meeting was held to develop this Standard. The make-up of this committee consists of power press brake manufacturers, distributors, and users.

The technical committee's objective was to develop a specification and performance standard for power press brakes.

To accomplish this objective, the committee approached this task by inviting the North American press brake manufacturers and users to submit basic data relative to the subject of this Standard so the committee could study, determine the variations, and obtain a consensus definition for a standard for power press brakes. This committee has adhered to the ANSI B5.51M-1987 Preferred Metric SI units for Machine Tools in the preparation of this Standard.

Following approval by ASME, the document was submitted to the American National Standards Institute, and was approved as an American National Standard on August 18, 1994.

Suggestions for improvement of this Standard are welcomed. They should be addressed to the Secretary, ASME B5 Committee, United Engineering Center, 345 E. 47th St., New York, N.Y. 10017.

### POWER PRESS BRAKE SAFETY REQUIREMENTS

The ASME B5.55M-1994 does not cover safety. Safety requirements for the construction, care, and use of power press brakes are established in the latest edition of the American National Standard B11.3.

**ASME STANDARDS COMMITTEE B5**  
**Machine Tools — Components, Elements, Performance, and Equipment**

(The following is the roster of the Committee at the time of approval of this Standard.)

**OFFICERS**

**H. Cooper**, *Chairman*  
**P. Stumpf**, *Secretary*

**COMMITTEE PERSONNEL**

**A. M. Bratkovich**, P.E., National Machine Tool Builders Association, McLean, Virginia  
**D. L. Lewis**, Kennametal, Inc., Raleigh, North Carolina  
**D. Lovett**, U. S. Department of Commerce, National Bureau of Standards, Gaithersburg, Maryland  
**G. R. Rawlinson**, P.E., Rawlinson & Associates, Crossville, Illinois  
**W. S. Roorda**, P.E., Alcona Associates, Inc., Venice, Florida

**TECHNICAL COMMITTEE 31 — PRESS BRAKES AND SHEARS**

**G. Rawlinson**, P.E., *Chairman*, Rawlinson & Associates, Inc.  
**R. L. Wonsetler**, *Vice Chairman*, R. W. Engineering Ltd.  
**R. M. Stein**, P.E., *Secretary*, RMS Engineering  
**W. S. Bamford**, Niagara Machine and Tool Works  
**A. M. Bratkovich**, P.E., The Association for Manufacturing Technology  
**R. R. Jelinek**, Wysong & Miles Co.  
**G. W. Kelly**, Caterpillar, Inc.  
**L. W. Mathis**, G.E. Mathis Co.  
**G. W. Munschauer**, Niagara Machine and Tool Works  
**J. E. Walker**, Pearl Equipment Co.

## CONTENTS

Foreword .....		iii
Standards Committee Roster .....		v
1	Scope, Purpose, and Application .....	1
2	Definitions and Terminology .....	1
3	Units of Dimension and Capacity .....	1
4	Machine Characteristics .....	1
5	Interface Specifications .....	3
6	Ergonomics .....	5
7	Acceptance Conditions .....	5
8	Provision for Information and Instruction .....	8
9	Manufacturer Declaration of Compliance .....	8
10	Reference Standards .....	9
<b>Figures</b>		
1	Power Press Brake Terminology .....	1
2	Press Brake Work Area Dimensions .....	3
3	Upper Tool Interface .....	5
4	Lower Tool Interface .....	5
5	Accessory Slot Dimensions .....	5
6	Ram Repeatability Test .....	6
7	Squareness Test .....	6
8	Flatness Test .....	7
9	Ram and Bed Deflection Test .....	7
10	Side Frame Deflection Test .....	7
11	Nameplate Location .....	8
12	Data Plate .....	8
<b>Tables</b>		
1	Standard Sizes .....	2
2	Standard Lengths .....	2
3	Dimensional Characteristics — Straight Hydraulic Press Brakes, mm (in.) .....	4
4	Dimensional Characteristics — Eccentric Press Brakes, mm (in.) .....	4
5	Accessory Slot Location .....	5

**Appendices**

A	Glossary of Terms .....	11
B	Metric/English Conversion Tables .....	15

## SPECIFICATION AND PERFORMANCE STANDARD, POWER PRESS BRAKES

### 1 SCOPE, PURPOSE, AND APPLICATION

#### 1.1 Scope

The requirements of this Standard apply to those power operated press brakes that are used to form metal by bending. This Standard specifically excludes machines referred to as hand brakes (leaf brake), folding brakes, tangent benders, apron brakes (box and pan), and swivel bending brakes.

#### 1.2 Purpose

The purpose of this Standard is to define and describe press brake size, capacity, and performance.

#### 1.3 Application

Any Press Brake referred to as an American National Standard Press Brake shall comply with all the requirements of this Standard.

### 2 DEFINITIONS AND TERMINOLOGY

The glossary provided in Appendix A is a list of definitions associated with the press brake industry and may or may not be referenced in this Standard (see Fig. 1).

### 3 UNITS OF DIMENSION AND CAPACITY

#### 3.1 Metrication

All units of dimension and capacity are per ANSI B5.51M-1979 (R1987), Preferred SI Units for Machine Tools. Equivalent English units are shown in parentheses.

#### 3.2 Conversion

A reference Metric/English Conversion Table is provided in Appendix B of this Standard.

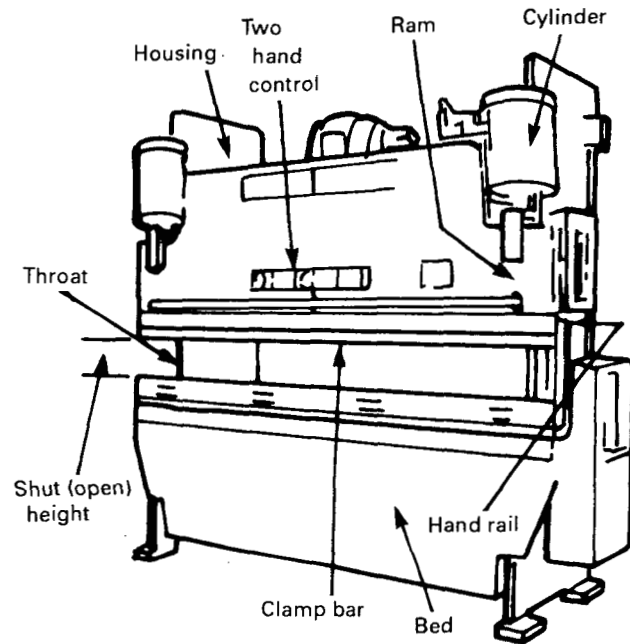

FIG. 1 POWER PRESS BRAKE TERMINOLOGY

### 4 MACHINE CHARACTERISTICS

For reasons of user utility and standardization, equipment conforming to this specification is specified in Table 1. The standard length designations for a standard size are shown in Table 2. Machines conforming to this Standard may be manufactured to lengths not shown in Table 2. Designation of machines is covered in para. 8.1.2.

#### 4.1 Forming Force

The required machine capacity for air bending shall be determined by the following equation:

Metric	English
$F = \frac{1.33 \times 10^6 SWt^2}{D - 1.41R}$	$F = \frac{1.33 SWt^2}{D - 1.41R}$



TABLE 1 STANDARD SIZES

Standard Size No.	Forming Capacity kN (Tons)	Punching Capacity kN (Tons)
1	175 (20)	116 (13)
2	300 (34)	200 (23)
3	500 (56)	333 (37)
4	800 (90)	533 (60)
5	1200 (135)	800 (90)
6	1600 (180)	1066 (120)
7	2000 (225)	1333 (150)
8	2500 (281)	1666 (187)
9	3000 (337)	2000 (225)
10	3500 (393)	2333 (262)
11	4000 (450)	2666 (300)
12	5000 (562)	3333 (375)
13	6500 (731)	4333 (487)
14	8750 (984)	5333 (656)
15	11000 (1236)	7333 (824)
16	13000 (1461)	8666 (974)
17	17500 (1967)	11665 (1311)

TABLE 2 STANDARD LENGTHS

Standard Size No.	Standard Letter Designation for Bed and Ram Length — mm (in.)								
	A	B	C	D	E	F	G	H	I
	1220 (48)	1830 (72)	2440 (96)	3050 (120)	3660 (144)	4270 (168)	4880 (192)	6100 (240)	7300 (288)
1	x								
2	x	x							
3		x	x						
4			x	x	x				
5			x	x	x				
6				x	x	x			
7				x	x	x			
8				x	x	x			
9				x	x	x	x		
10					x	x	x	x	
11					x	x	x	x	x
12					x	x	x	x	x
13					x	x	x	x	x
14					x	x	x	x	x
15									
16									
17									
Minimum Distance Between Housings	910 (36)	1575 (62)	1980 (78)	2590 (102)	3200 (126)	3810 (150)	4420 (174)	5635 (222)	6600 (260)

where:

- $F$  = force, kN (lbf)
- $S$  = ultimate tensile strength, kPa (psi)
- $W$  = length of bend, mm (in.)
- $t$  = stock thickness, mm (in.)
- $D$  = the V-die opening, mm (in.)
- $R$  = Radius of upper tool tip, mm (in.)

#### 4.2 Punching Force

The applied punching force should not exceed  $\frac{2}{3}$  of the rated machine forming capacity. The required machine hole punching capacity shall be determined by the following equation:

Metric	English
$F = S \times L \times t \times 10^3$	$F = S \times L \times t$

where:

- $F$  = punching force, kN (lbf)
- $S$  = shear strength, kPa (psi)
- $L$  = circumference of punch shape, mm (in.)
- $t$  = stock thickness, mm (in.)

#### 4.3 Length

The equipment conforming to this Standard shall have a minimum overall bed and ram tooling interface length as tabulated in Table 1.

#### 4.4 Work Area Dimensional Requirements

**4.4.1 Straight Hydraulic Press Brakes.** Equipment conforming to this Standard shall provide, as a minimum, a work area and tooling interface capacity as defined in Fig. 2 and Table 3.

**4.4.2 Eccentric Press Brakes.** Eccentric press brakes are eccentrically operated and powered by either mechanical or hydraulic drives. Equipment conforming to this Standard shall provide, as a minimum, a work area and tooling interface capacity as defined in Fig. 2 and Table 4.

#### 4.5 Bed Height

The distance from the floor to the top of the bed shall be no less than 750 mm (30 in.) and no greater than 1000 mm (40 in.).

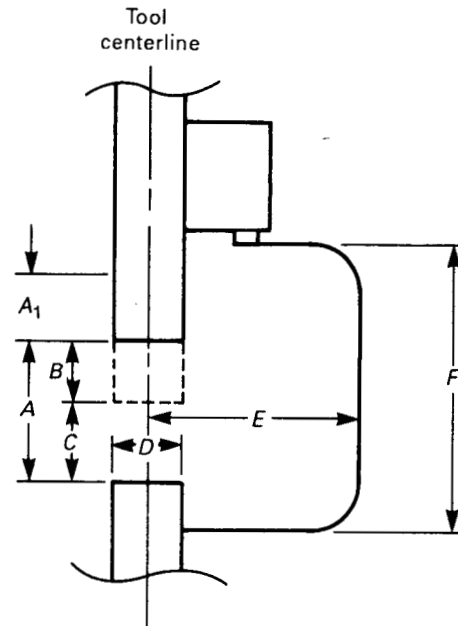

FIG. 2 PRESS BRAKE WORK AREA DIMENSIONS

#### 4.6 Preferred Sizes

This Standard defines press brakes ranging in size from 175 kN to 17,500 kN (20-2000 tons) forming capacity. Equipment conforming to this Standard shall be designed to provide punching capacity equal to  $\frac{2}{3}$  of the rated forming capacity in mild steel. Seventeen standard sizes are defined in Table 1. Equipment falling between two standard capacity sizes will be grouped with the lower standard size for designation.

Nine standard lengths are defined in Table 2 and are cross-referenced to the standard size number for which they are available. Lengths falling between two standard lengths will be grouped with the shorter length for designation.

### 5 INTERFACE SPECIFICATIONS

#### 5.1 Tooling Interface

Provisions shall be provided for the attachment of tools to the machine.

**5.1.1 Upper Tool Interface.** The means of attachment for the upper tool to the ram shall conform to Fig. 3.

**5.1.2 Lower Tool Interface.** A means to secure tooling to the machine bed shall be provided and shall

**TABLE 3 DIMENSIONAL CHARACTERISTICS — STRAIGHT HYDRAULIC PRESS  
BRAKES, mm (in.)**

Standard Size No.	A Open Height	B Stroke	C Closed Height	D Bed Width	E Throat Depth	F Throat Height
1	300 (12)	175 (7)	125 (5)	50(2)	150 (6)	200 (8)
2	300 (12)	175 (7)	125 (5)	50 (2)	150 (6)	200 (8)
3	300 (12)	175 (7)	125 (5)	50 (2)	150 (6)	200 (8)
4	300 (12)	175 (7)	125 (5)	75 (3)	150 (6)	250 (10)
5	300 (12)	175 (7)	125 (5)	75 (3)	175 (7)	250 (10)
6	380 (15)	250 (10)	130 (5)	125 (5)	200 (8)	250 (10)
7	380 (15)	250 (10)	130 (5)	125 (5)	200 (8)	250 (10)
8	500 (20)	250 (10)	250 (10)	125 (5)	250 (10)	380 (15)
9	500 (20)	250 (10)	250 (10)	125 (5)	250 (10)	380 (15)
10	500 (20)	300 (12)	250 (10)	175 (5)	250 (10)	380 (15)
11	560 (22)	300 (12)	250 (10)	200 (8)	250 (10)	450 (18)
12	560 (22)	300 (12)	250 (10)	200 (8)	250 (10)	450 (18)
13	560 (22)	300 (12)	250 (10)	300 (12)	300 (12)	500 (20)
14	560 (22)	300 (12)	250 (10)	400 (16)	350 (14)	500 (20)
15	760 (30)	450 (18)	300 (12)	450 (18)	400 (16)	500 (20)
16	760 (30)	450 (18)	300 (12)	500 (20)	450 (18)	500 (24)
17	760 (30)	450 (18)	300 (12)	600 (24)	500 (20)	500 (24)

**TABLE 4 DIMENSIONAL CHARACTERISTICS — ECCENTRIC PRESS  
BRAKES mm (in.)**

Standard Size No.	A [Note (1)]	A <sub>1</sub> [Note (2)]	B	C	D	E	F
1	225 (9)	75 (3)	50 (2)	75 (3)	50 (2)	150 (6)	300 (12)
2	225 (9)	75 (3)	50 (2)	75 (3)	50 (2)	200 (8)	300 (12)
3	300 (12)	75 (3)	75 (3)	75 (3)	75 (3)	200 (8)	300 (12)
4	300 (12)	100 (4)	75 (3)	75 (3)	75 (3)	200 (8)	300 (12)
5	300 (12)	100 (4)	75 (3)	125 (5)	75 (3)	200 (8)	300 (12)
6	300 (12)	125 (5)	75 (3)	125 (5)	125 (5)	200 (8)	300 (12)
7	300 (12)	125 (5)	75 (3)	125 (5)	125 (5)	200 (8)	300 (12)

## NOTES:

- (1) Die space defined ram down ram adjustment up.  
(2) Ram adjustment range.

A = Open Height  
C = Shut Height  
F = Throat Height

A<sub>1</sub> = Ram Adjustment  
D = Bed Width

B = Stroke  
E = Throat Depth

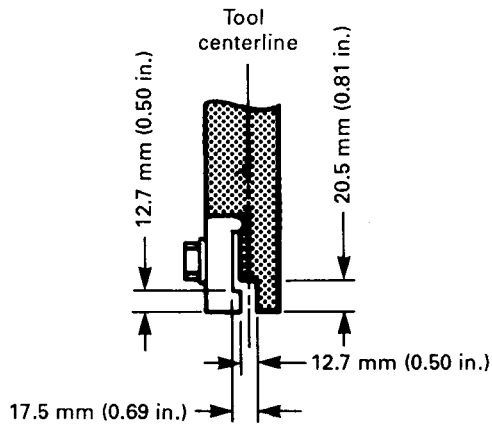

FIG. 3 UPPER TOOL INTERFACE

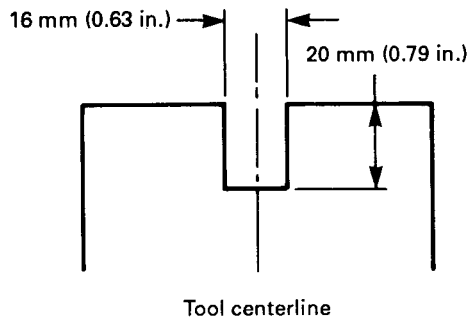

FIG. 4 LOWER TOOL INTERFACE

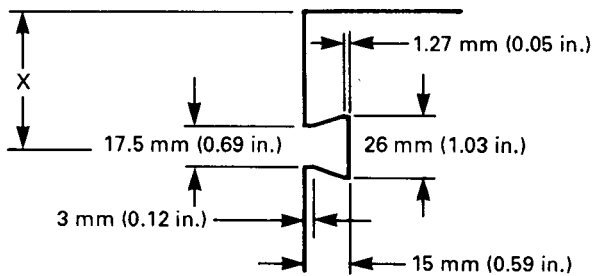

FIG. 5 ACCESSORY SLOT DIMENSIONS

not inhibit tool alignment. When a bed center slot is provided it shall comply with Fig. 4. A means shall be provided to align the lower tool with the press brake.

**5.1.3 Accessory Slot Dimensions.** When provided, T-slots shall comply with ANSI/ASME B5.1M-1985 and shall be located per dimension X in Fig. 5.

When provided, dovetail slots shall comply with Fig. 5 and Table 5.

TABLE 5 ACCESSORY SLOT LOCATION

Standard Size	X	
	mm	(in.)
1-8	51	(2)
9-17	63.5	(2-1/2)

## 6 ERGONOMICS

### 6.1 Operator Control Locations

Operator controls shall comply with ANSI B11.3.

## 7 ACCEPTANCE CONDITIONS

### 7.1 General Conditions

This specification and performance standard defines two commercial classifications of machine accuracy. Prior to testing, the press brake shall be installed on a suitable foundation with all the necessary services connected in accordance with the manufacturers specifications. Each test describes a suggested method of verifying acceptance conditions and states the required tolerance. Other test methods are acceptable, but changes in the specified tolerance are not.

**7.1.1 Class I Press Brakes.** Class I — machines are defined for high accuracy air bending applications. Machines of Class I accuracy are recommended to be limited to 5 mm (.197 in.) and lighter forming capacity corresponding to standard size 9 (3000 kN) in any standard length up to 6100 mm (242 in.).

**7.1.2 Class II Press Brakes.** Class II — machine specification and performance is for general purpose metal forming operations. These machines may therefore be specified in any combination of 17 standard sizes defined in Table 1 and matrix of preferred lengths defined in Table 2.

### 7.2 Accuracy

Tolerances specified shall be absolute values independent of statistical analysis.

**7.2.1 Test 1 — Ram Repeatability.** Indicators are to be mounted rigidly to the bed of the press brake, as shown in Fig. 6 with the stylus of the indicator positioned to contact the tooling support shoulder of the ram when the ram is at the bottom of its stroke. The press

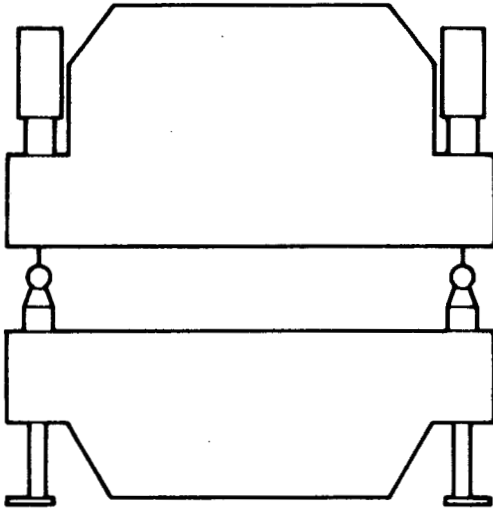

FIG. 6 RAM REPEATABILITY TEST

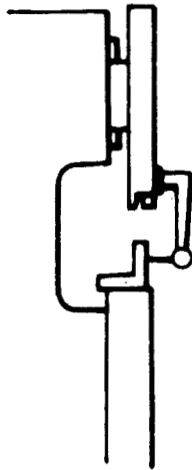

FIG. 7 SQUARENESS TEST

brake ram is stroked and the indicator readings are checked for repeatability within the specified tolerance.

Tolerance:

Class I:  $\pm 0.01$  mm (.0004 in.)

Class II:  $\pm 0.05$  mm (.002 in.)

**7.2.2 Test 2 — Ram Squareness to Bed.** An inspection quality angle plate is fixed to the bed of the press brake. The indicator is mounted rigidly to the ram with the stylus of the indicator contacting the vertical face of the angle plate, as shown in Fig. 7. The ram is stroked and the indicator reading is checked for varia-

tions outside of the specified tolerance. This procedure is to be performed at both ends and the center of the press brake.

Tolerance:

Class I: 0.05 mm/100 mm (.006 in./ft)

Class II: 0.1 mm/100 mm (.012 in./ft)

**7.2.3 Test 3 — Flatness of Bed and Ram Surfaces.** Align an inspection quality straight edge parallel to the press brake bed, as shown in Fig. 8, and, using a slide base mounted indicator, verify the distance between the top of the bed and straight edge to be equal. Slide the indicator and base along the top of the bed with the stylus of the indicator contacting the straight edge and check the indicator reading for compliance to the specified tolerance. Repeat this procedure after paralleling the straight edge to the ram of the press brake.

Ram and bed parallelism is an operating parameter of a press brake and the exact value is established by the operator during set-up.

Tolerance:

Class I: 0.05 mm/1000 mm (.0006 in./ft)

Class II: 0.1 mm/1000 mm (.0012 in./ft)

### 7.3 Frame Deflection

**7.3.1 Test 4 — Ram and Bed Deflection Under Load.** Three indicators are mounted rigidly to a stable independent beam mounted to the press brake side frames as shown in Fig. 9, with the stylus contacting the tooling support shoulder of the ram. The ram is stroked with no material being formed and the indicators are zeroed at the bottom of the stroke. The ram is stroked again, this time with material equivalent to the maximum capacity of the press brake being formed and distributed over no less than  $\frac{2}{3}$  the bed length. The indicator readings are recorded with the ram at the bottom of the stroke. The indicator readings are then interpolated to determine the amount of ram deflection. The test is repeated after the indicators are reset with the stylus contacting the top of the press brake bed.

Tolerance - Test 4a. - Ram:

Class I: 0.1 mm/1000 mm (.0012 in./ft)

Class II: 0.1 mm/1000 mm (.0012 in./ft)

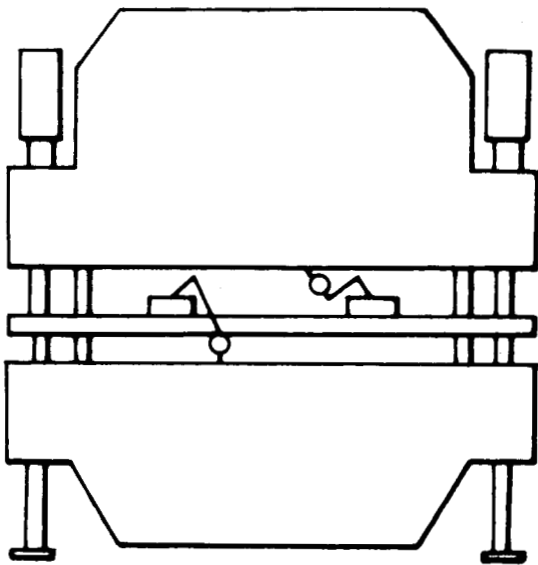

FIG. 8 FLATNESS TEST

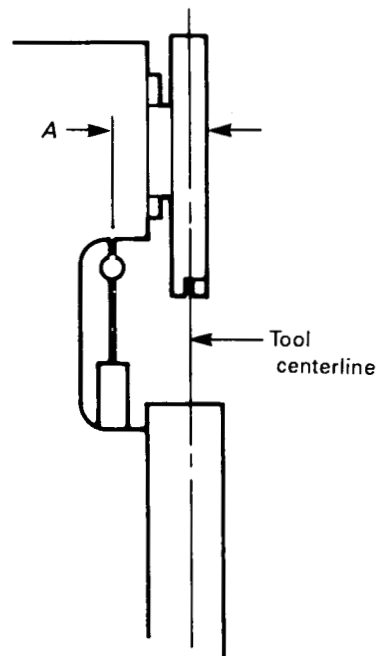

FIG. 10 SIDE FRAME DEFLECTION TEST

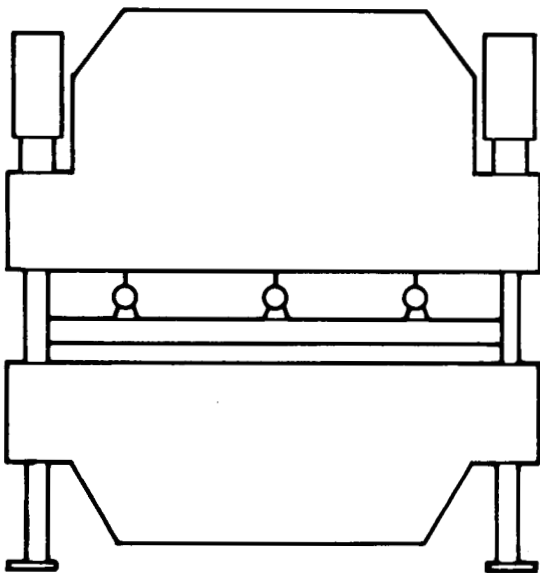

FIG. 9 RAM AND BED DEFLECTION TEST

frame at a measured distance from the ram centerline with the stylus contacting the lower surface of the upper arm of the end frame, as shown in Fig. 10. The ram is stroked with material being formed which is equivalent to the maximum capacity of the press brake. The indicator reading is recorded and the total deflection at the tool centerline is linearly interpolated from the measurement.

Tolerance:

Class I: 3.0 mm/1000 mm (.003 in./in.)

Class II: 3.0 mm/1000 mm (.003 in./in.)

Interpolation Formula:

$$D = \frac{R}{A}$$

where:

$D$  = deflection tolerance

$R$  = indicator reader mm (in.)

$A$  = setup dimension mm (in.)

Tolerance - Test 4b. - Bed:

Class I: 0.1 mm/1000 mm (.0012 in./ft)

Class II: 0.1 mm/1000 mm (.0012 in./ft)

**7.3.2 Test 5 — Side Frame Deflection.** An indicator is mounted rigidly to the lower arm of the side

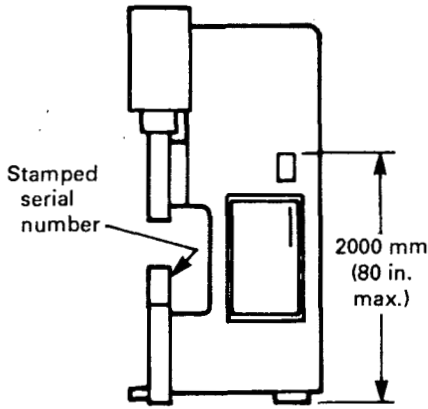

FIG. 11 NAMEPLATE LOCATION

**8 PROVISION FOR INFORMATION AND INSTRUCTION**

**8.1 Information**

**8.1.1 Nameplate.** The manufacturer shall provide an identification data plate of durable metal. The data is to be permanently attached to the outside of the right hand side frame at a height not to exceed 2000 mm (79 in.) from floor level, as shown in Fig. 11. The data plate shall display all information relative to the equipment, per Fig. 12.

In addition to the data plate, the equipment serial number shall be stamped on the right end of the bed just below the die mounting surface, as shown in Fig. 11, in letters and numerals at least 6 mm (.238 in.) high.

**8.1.2 Machine Designation.** Machines conforming to this Standard will utilize a two character suffix addition to the model designation. The suffix will be comprised of the standard size number from Table 1 and the standard length letter from Table 2.

Example:

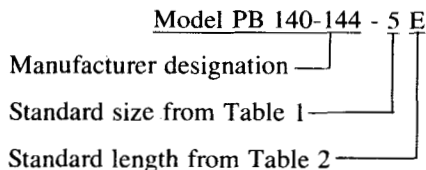

**8.1.3 Documentation Package.** The manufacturer shall establish and maintain a file defining the press brake configuration at the time of construction. This file shall at the minimum include the principal physical features of the machine, description of power and control

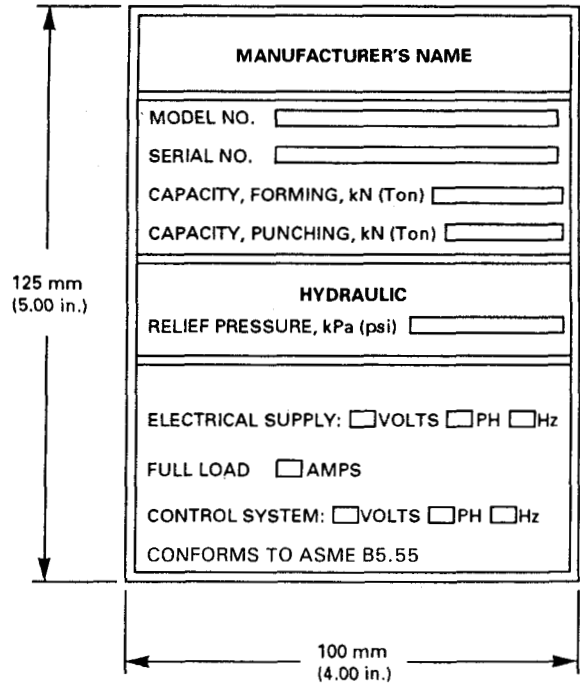

FIG. 12 DATA PLATE

systems (electrical, electronic, hydraulic, pneumatic), and engineering documentation of all related components and systems.

**8.2 Instruction Manual**

The manufacturer shall provide a minimum of two copies of the instruction manual containing information relevant to proper installation, operation, care, and maintenance of the equipment. The manuals shall be printed in English and bound as a permanent reference document for the equipment.

**9 MANUFACTURER DECLARATION OF COMPLIANCE**

**9.1 Certificate of Compliance**

Upon request, the machine manufacturer shall provide a certificate of compliance with this Standard. The certificate is to include the following information:

Title: B5.55 Compliance

Manufacturer -

Machine Model -

Machine Serial No. -

Date -

## 10 REFERENCE STANDARDS

### 10.1 Safety and Health

ANSI B11.3, Safety Requirements for the Construction, Care, and Use of Power Press Brakes

ANSI B11.19, Performance Criteria for the Design, Construction, Care, and Operation of Safeguarding When Referenced by the Other B11 Standards

ANSI B15.1, Safety Standard for Mechanical Power Transmission Apparatus

ANSI Z44.1, Lockout Tagout

NFPA 79, Electrical Standard for Industrial Machinery

OSHA 1910.95, Occupational Noise Exposure

OSHA 1910.211, Machinery and Machine Guarding, Definitions

OSHA 1910.212, Machinery and Machine Guarding, General Requirements for All Machines

OSHA 1910.219, Machinery and Machine Guarding, Mechanical Power Transmission Apparatus

### 10.2 Other References

ANSI B5.1M-1985, T-Slots, Their Bolts, Nuts, and Tongues

ANSI B5.51M-1987, Preferred SI Units for Machine Tools



## APPENDIX A GLOSSARY OF TERMS

(This Appendix is an integral part of ASME B5.55M-1994 and is placed after the main text for convenience.)

Terms relevant to this Standard and its application are as follows:

*actuating means (controls)* — see *control, hand; control, foot or PSD; control, pedal (treadle); two hand trip*

*air bending* — the forming of sheet or plate using a “V” die where the desired angle is achieved before the workpiece is compressed between the upper and lower tools

*anti-repeat* — that function of the control system designed to limit the press brake to a single cycle (stroke) if the tripping or actuating means is held operated

*automatic (full)* — see *continuous*

*barrier* — a physical boundary to a hazard

*base* — the basic and primary structure of the machine

*bed* — the stationary member of the press brake that supports the tooling and other associated equipment (see *base*)

*bending* — the application of stress concentrated at specific points on the workpiece to permanently turn, press, or force from straight, level, or flat condition to a curved or angular configuration

*bending, multiple* — the forming of two or more bends in a single workpiece or in two or more workpieces with each cycle of the press brake

*bending, progressive* — the forming of a number of bends in the same or different plane or angles, one after another, on a single workpiece at one station

*bolster (bolster plate)* — the plate(s) attached to the bed or slide(s) (ram) having means for attaching die components

*bottom bending* — the forming of sheet or plate using a “V” die where the desired angle is completed after the workpiece is compressed between the upper and lower tools. Typically requires 3–5 times the tonnage for air bending.

*brake* — a mechanism for stopping, slowing, or preventing motion

*caution* — see *warning*

*closed height* — see *shut height*

*clutch* — an assembly, that when engaged, transmits torque to impart motion from a driving member to a driven member

*cold working* — the plastic deformation of metal without the addition of external heat

*coining* — a method of bottom bending where additional force is applied during the bend to make the workpiece conform to the shape of the upper and lower tools. Typically uses “V” dies with openings of 6 times the material thickness and requires 5–7 times the tonnage for air bending.

*connection (connecting rod) (pitman)* — the part of the press brake that transmits motion and force from the revolving crank or eccentric to the slide (ram)

*continuous (automatic) (full automatic)* — uninterrupted, multiple cycles (strokes) without intervening stops at the end of an individual cycle (stroke)

*control, foot* — a foot operated mechanism (other than a mechanical pedal) for use with the press brake control system.

*control, foot pedal (mechanical)* — a foot operated lever designed to actuate and engage the clutch and disengage the brake to cause ram (slide) motion

*control, hand* — a hand operated actuating mechanism for use with press brake control system

*control, operator* — a pushbutton, switch, lever, hand-wheel, or other device activated by the operator which initiates, cycles, controls, or stops motion of the press brake

*control, presence sensing device (PSD)* — a presence sensing device (PSD) used as an actuating means

*control, (emergency) (master) stop* — a control that, when actuated, initiates immediate or controlled stopping action of the motion of the press brake

*control, stop or return* — a control that, when actuated, initiates immediate or controlled stopping action of motion and causes the slide(s) (ram) to return to its initial open position

*control, two hand* — a control arrangement that requires the concurrent use of both of the operators hands to initiate or continue the press brake cycle (stroke) (see *device, two hand control*)

*counterbalance (system)* — means provided to balance the reciprocating weight of the slide (ram), drive members, and slide (ram) attachments

*cycle (work, machine, or single cycle; single stroke)* — a complete movement from the initial start position back to the same start position of the press brake slide (ram) which may include loading and unloading

*die(s)* — the tooling used in a press brake for shearing, punching, forming, drawing, or assembling metal or other material

*die holder* — the plate or rail to which the lower portion of the die member is attached

*die space* — the space between the bed and the slide (ram) (see *open height, shut height, closed height*)

*dies, bending* — dies used in press brakes to perform bending and forming operations on a variety of workpieces

*eccentric* — the offset portion of the main shaft or main gear that governs the distance that the slide (ram) travels

*ergonomics* — the study of the worker/machine interface for the purpose of adapting the workplace, machine, and job to fit the worker

*feeding* — the process of loading or removing material or workpieces into or from the press brake

*frame* — see *base*

*gauge, material position* — a stop against which the material or workpiece is placed to locate it within the point of operation

*gap* — see *throat*

*gibs* — the machine members used for guiding the ram (slide)

*guard* — a barrier which prevents entry into the point of operation or other hazard area (zone)

*guard, cover (excludes point of operation)* — see *guard*

*Housing* — see *base*

*inch* — to impart momentary motion to the press brake by manual means

*jog* — see *inch*

*manual (operation)* — the operation of the press brake requiring the operator to initiate and maintain the motion of the machine during the cycle (stroke) or a portion of the cycle (stroke) by use of the actuating means

*manufacturer* — any builder, reconstructor, modifier, or supplier of the press brake and its component parts

*mode* — the state or condition of the control system which allows specific operations of the press brake

*operator* — an individual who performs production work and who controls the press brake

*pitman* — see *connection*

*plate* — flat material having dimensions of over 5 mm (7 gauge) thickness and 228 mm (9 in.) or more in width

*point of entry* — the opening(s) of a press brake through which the material or workpiece is placed (inserted) for processing

*point of operation* — the location in the press brake where the material or a workpiece is positioned and work is performed

*programmable logic control* — an electronic system which performs logical, decision making, or arithmetic functions by executing instructions in a specific manner. A PES usually includes input and output elements (ports) and is usually reprogrammable.

*punch* — the male part of the tool (die)

*punch, bending* — that tooling normally attached to the ram of a bending machine to establish a specific material contour

*ram* — see *slide*

*run* — single or continuous cycling (stroking) of a press brake

*safeguarding* — methods for protection of personnel from hazards using guards, safety devices, or safe work procedures

*safeguarding, safe distance* — a method of workpiece positioning and operator location that eliminates the need for the operator to be in or near the point of operation during the press brake cycle (stroke)

*screws, shut height adjustment* — the screws used to set the shut height of the press brake

*selector, mode (stroking) (operating mode)* — one or more means used to establish the press brake operating sequence

*setup* — the process of adjusting the press brake and the installation and adjustment of work holding devices or tooling and appropriate safeguarding to ensure proper and safe operation of the press brake

*sheet* — flat material having dimensions less than or equal to 5 mm (7 gauge) thickness and 228 mm (9 in.) or more in width

*shut height* — the distance from the bed to the slide (ram) when the slide (ram) is at the bottom of its stroke (in the closed position)

*shut height (mechanical)* — the distance from the bed to the slide (ram) when the slide (ram) is at the bottom of its stroke (in the closed position) with the ram adjustment fully retracted

*single stroke (cycle) capability* — a mechanism or control arrangement used to automatically initiate stopping action of the press brake (slide) (ram) at the completion of the cycle (stroke)

*slide (ram)* — a linear moving press brake member configured to carry a portion of the tooling

*springback* — the opening of the V form angle in a workpiece resulting from the release of the forming pressure and relaxation of the workpiece

*steel, mild* — a nonalloyed ferrous material with a maximum tensile strength of 450 MPa (65,000 psi)

*steel, structural* — a nonalloyed ferrous material with a maximum tensile strength of 600 MPa (87,000 psi)

*stop control, emergency* — see *control, (emergency) (master) stop*

*stop, top (cycle) (stroke)* — an operator control used to stop continuous cycling (stroking) at the end of the cycle (stroke) or at another predetermined point

*stroke (half cycle)* — the distance that the slide (ram) travels from the open to the closed position [the movement of the slide (ram) from the open to the closed position]

*throat (gap)* — an opening or recess in the frame (housing) to permit the positioning of material or workpieces

*treadle bar (foot)* — the operating bar that extends the full length of the press brake and to which a foot pedal (treadle) may be attached

*trip (tripping)* — the momentary actuation of the press brake control or mechanism to initiate the press brake cycle (stroke)

*two hand trip* — an actuating means that requires concurrent use of both hands of the operator to trip the press brake

*V-Bending* — the forming of sheet metal material using a pair of “V” shaped tools that bend the workpiece by applying a three point load

**APPENDIX B**  
**METRIC/ENGLISH CONVERSION TABLES**

(This Appendix is an integral part of ASME B5.55M-1994 and is placed after the main text for convenience.)

(See Table on following page.)

Length		Force			
		Tons to Kilonewtons		Kilonewtons to Tons	
Inches	mm	Tons	kN	kN	Tons
0.001	0.0254	1.0	8.9	1.0	0.1124
0.005	0.1270	5.0	44.5	5.0	0.5620
0.010	0.2540	10.0	89.0	10.0	1.1240
0.015	0.3810	20.0	178.0	25.0	2.8100
0.020	0.5080	30.0	267.0	50.0	5.6200
0.030	0.7620	40.0	365.0	100.0	11.2400
0.040	1.0160	50.0	445.0	250.0	28.1000
0.050	1.2700	100.0	890.0	500.0	56.2000
0.060	1.5230	500.0	4450.0	1000.0	112.4000
0.070	1.7780	1000.0	8900.0	2500.0	280.9000
0.080	2.0320				
0.090	2.2860				
0.100	2.5400				
0.125	3.1800				
0.250	6.3500				
0.500	12.7000				
0.750	19.0500				
1.000	25.4000				
2.000	50.8000				
3.000	76.2000				
4.000	101.6000				
5.000	127.0000				
6.000	152.4000				
7.000	177.8000				
8.000	203.2000				
9.000	228.6000				
10.000	254.0000				
20.000	508.0000				
30.000	762.0000				
40.000	1016.0000				
50.000	1270.0000				
100.000	2540.0000				
Length		Pressure			
		Pounds/Sq. Inch to Kilopascal		Kilopascal to Pounds/Sq. Inch	
psi	kPa	kPa	psi	kPa	psi
1.0	6.90	6.90	1.0	1.0	0.145
5.0	34.48	34.48	5.0	5.0	0.730
10.0	68.95	68.95	10.0	10.0	1.450
20.0	137.90	137.90	25.0	25.0	3.630
30.0	206.85	206.85	50.0	50.0	7.250
40.0	275.80	275.80	100.0	100.0	14.500
50.0	344.80	344.80	250.0	250.0	36.260
100.0	689.50	689.50	500.0	500.0	72.520
250.0	1723.80	1723.80	1000.0	1000.0	145.000
500.0	3447.50	3447.50	2000.0	2000.0	290.100
1000.0	6895.00	6895.00	5000.0	5000.0	725.200
2000.0	13790.00	13790.00	10000.0	10000.0	1450.300



This document is printed  
on 50% recycled paper.

ISBN #0-7918-2305-9



M15194