

# Welding Processes, Inspection, and Metallurgy

API RECOMMENDED PRACTICE 577  
SECOND EDITION, DECEMBER 2013



AMERICAN PETROLEUM INSTITUTE

## Special Notes

API publications necessarily address problems of a general nature. With respect to particular circumstances, local, state, and federal laws and regulations should be reviewed.

Neither API nor any of API's employees, subcontractors, consultants, committees, or other assignees make any warranty or representation, either express or implied, with respect to the accuracy, completeness, or usefulness of the information contained herein, or assume any liability or responsibility for any use, or the results of such use, of any information or process disclosed in this publication. Neither API nor any of API's employees, subcontractors, consultants, or other assignees represent that use of this publication would not infringe upon privately owned rights.

API publications may be used by anyone desiring to do so. Every effort has been made by the Institute to assure the accuracy and reliability of the data contained in them; however, the Institute makes no representation, warranty, or guarantee in connection with this publication and hereby expressly disclaims any liability or responsibility for loss or damage resulting from its use or for the violation of any authorities having jurisdiction with which this publication may conflict.

API publications are published to facilitate the broad availability of proven, sound engineering and operating practices. These publications are not intended to obviate the need for applying sound engineering judgment regarding when and where these publications should be utilized. The formulation and publication of API publications is not intended in any way to inhibit anyone from using any other practices.

Any manufacturer marking equipment or materials in conformance with the marking requirements of an API standard is solely responsible for complying with all the applicable requirements of that standard. API does not represent, warrant, or guarantee that such products do in fact conform to the applicable API standard.

All rights reserved. No part of this work may be reproduced, translated, stored in a retrieval system, or transmitted by any means, electronic, mechanical, photocopying, recording, or otherwise, without prior written permission from the publisher. Contact the Publisher, API Publishing Services, 1220 L Street, NW, Washington, DC 20005.

*Copyright © 2013 American Petroleum Institute*

## Foreword

Nothing contained in any API publication is to be construed as granting any right, by implication or otherwise, for the manufacture, sale, or use of any method, apparatus, or product covered by letters patent. Neither should anything contained in the publication be construed as insuring anyone against liability for infringement of letters patent.

This document was produced under API standardization procedures that ensure appropriate notification and participation in the developmental process and is designated as an API standard. Questions concerning the interpretation of the content of this publication or comments and questions concerning the procedures under which this publication was developed should be directed in writing to the Director of Standards, American Petroleum Institute, 1220 L Street, NW, Washington, DC 20005. Requests for permission to reproduce or translate all or any part of the material published herein should also be addressed to the director.

Generally, API standards are reviewed and revised, reaffirmed, or withdrawn at least every five years. A one-time extension of up to two years may be added to this review cycle. Status of the publication can be ascertained from the API Standards Department, telephone (202) 682-8000. A catalog of API publications and materials is published annually by API, 1220 L Street, NW, Washington, DC 20005.

Suggested revisions are invited and should be submitted to the Standards Department, API, 1220 L Street, NW, Washington, DC 20005, [standards@api.org](mailto:standards@api.org).





# Contents

	Page
<b>1</b>	<b>Scope</b> . . . . . <b>1</b>
<b>2</b>	<b>Normative References</b> . . . . . <b>1</b>
<b>3</b>	<b>Terms, Definitions, and Acronyms</b> . . . . . <b>2</b>
<b>3.1</b>	<b>Terms and Definitions</b> . . . . . <b>2</b>
<b>3.2</b>	<b>Acronyms</b> . . . . . <b>10</b>
<b>4</b>	<b>Welding Inspection</b> . . . . . <b>10</b>
<b>4.1</b>	<b>General</b> . . . . . <b>10</b>
<b>4.2</b>	<b>Tasks Prior to Welding</b> . . . . . <b>10</b>
<b>4.3</b>	<b>Tasks During Welding Operations</b> . . . . . <b>16</b>
<b>4.4</b>	<b>Tasks Upon Completion of Welding</b> . . . . . <b>18</b>
<b>4.5</b>	<b>Non-Conformances and Defects</b> . . . . . <b>21</b>
<b>4.6</b>	<b>NDE Examiner Certification</b> . . . . . <b>21</b>
<b>4.7</b>	<b>Safety Precautions</b> . . . . . <b>23</b>
<b>5</b>	<b>Welding Processes</b> . . . . . <b>23</b>
<b>5.1</b>	<b>General</b> . . . . . <b>23</b>
<b>5.2</b>	<b>Shielded Metal Arc Welding (SMAW)</b> . . . . . <b>23</b>
<b>5.3</b>	<b>Gas Tungsten Arc Welding (GTAW)</b> . . . . . <b>25</b>
<b>5.4</b>	<b>Gas Metal Arc Welding (GMAW)</b> . . . . . <b>27</b>
<b>5.5</b>	<b>Flux Cored Arc Welding (FCAW)</b> . . . . . <b>30</b>
<b>5.6</b>	<b>Submerged Arc Welding (SAW)</b> . . . . . <b>33</b>
<b>5.7</b>	<b>Stud Arc Welding (SW)</b> . . . . . <b>33</b>
<b>5.8</b>	<b>Plasma Arc Welding (PAW)</b> . . . . . <b>35</b>
<b>5.9</b>	<b>Electrode Gas Welding (EGW)</b> . . . . . <b>36</b>
<b>6</b>	<b>Welding Procedure</b> . . . . . <b>38</b>
<b>6.1</b>	<b>General</b> . . . . . <b>38</b>
<b>6.2</b>	<b>Welding Procedure Specification (WPS)</b> . . . . . <b>38</b>
<b>6.3</b>	<b>Procedure Qualification Record (PQR)</b> . . . . . <b>40</b>
<b>6.4</b>	<b>Reviewing a WPS and PQR</b> . . . . . <b>40</b>
<b>6.5</b>	<b>Tube-to-Tubesheet Welding Procedures</b> . . . . . <b>43</b>
<b>7</b>	<b>Welding Materials</b> . . . . . <b>44</b>
<b>7.1</b>	<b>General</b> . . . . . <b>44</b>
<b>7.2</b>	<b>P-Number Assignment to Base Metals</b> . . . . . <b>44</b>
<b>7.3</b>	<b>F-Number Assignment to Filler Metals</b> . . . . . <b>44</b>
<b>7.4</b>	<b>AWS Classification of Filler Metals</b> . . . . . <b>45</b>
<b>7.5</b>	<b>A-Number</b> . . . . . <b>45</b>
<b>7.6</b>	<b>Filler Metal Selection</b> . . . . . <b>45</b>
<b>7.7</b>	<b>Consumable Storage and Handling</b> . . . . . <b>46</b>
<b>8</b>	<b>Welder Qualification</b> . . . . . <b>46</b>
<b>8.1</b>	<b>General</b> . . . . . <b>46</b>
<b>8.2</b>	<b>Welder Performance Qualification (WPQ)</b> . . . . . <b>46</b>
<b>8.3</b>	<b>Reviewing a WPQ</b> . . . . . <b>47</b>
<b>9</b>	<b>Non-destructive Examination</b> . . . . . <b>48</b>

	Page
9.1 Discontinuities.....	48
9.2 Materials Identification.....	50
9.3 Visual Examination (VT).....	52
9.4 Magnetic Particle Examination (MT).....	57
9.5 Alternating Current Field Measurement (ACFM).....	64
9.6 Liquid Penetrant Examination (PT).....	64
9.7 Eddy Current Examination (ET).....	66
9.8 Radiographic Examination (RT).....	66
9.9 Ultrasonic Examination (UT).....	73
9.10 Hardness Testing.....	90
9.11 Pressure and Leak Testing (LT).....	91
9.12 Weld Inspection Data Recording.....	92
10 Metallurgy.....	94
10.1 General.....	94
10.2 The Structure of Metals and Alloys.....	95
10.3 Physical Properties.....	97
10.4 Mechanical Properties.....	99
10.5 Preheating.....	101
10.6 Postweld Heat Treatment.....	102
10.7 Hardening.....	103
10.8 Material Test Reports.....	104
10.9 Weldability of Metals.....	105
10.10 Weldability of high-alloys	108
11 Refinery and Petrochemical Plant Welding Issues.....	109
11.1 General.....	109
11.2 Hot Tapping and In-Service Welding.....	109
11.3 Lack of Fusion with GMAW-S Welding Process.....	112
11.4 Caustic Service.....	113
Annex A (normative) Terminology and Symbols.....	114
Annex B (normative) Actions to Address Improperly Made Production Welds.....	120
Annex C (informative) Welding Procedure Review.....	122
Annex D (normative) Guide To Common Filler Metal Selection.....	140
Annex E (informative) Example Report of RT Results.....	144
Bibliography.....	145
<b>Figures</b>	
1 SMAW Welding.....	24
2 SMAW Welding Electrode During Welding.....	24
3 GTAW Welding Equipment.....	26
4 GTAW Welding.....	27
5 GMAW Equipment.....	28
6 GMAW Welding.....	28
7 FCAW Equipment.....	31
8 FCAW Welding.....	32
9 FCAW Welding, Self-shielded.....	32

10	SAW Welding . . . . .	34
11	Comparison of the Gas Tungsten Arc and Plasma Arc Welding Processes . . . . .	35
12	Electrode Gas Welding with a Solid Electrode . . . . .	37
13	Typical Discontinuities Present in a Single Bevel Groove Weld in a Butt Joint . . . . .	50
14	Direct Visual Examination Requirements . . . . .	53
15	Inspector's Kit . . . . .	55
16	Bridge Cam Gauge . . . . .	56
17	Adjustable Fillet Weld Gauge . . . . .	56
18	Skew—T Fillet Weld Gauge . . . . .	57
19	Weld Fillet Gauge . . . . .	58
20	Weld Fillet Gauge . . . . .	58
21	Weld Size Gauge . . . . .	59
22	Hi-Lo Gauge . . . . .	59
23	Surface-breaking Discontinuity . . . . .	60
24	Subsurface Discontinuity . . . . .	60
25	Weld Discontinuity . . . . .	61
26	Flux Lines . . . . .	62
27	Detecting Discontinuities Transverse to Weld . . . . .	62
28	Detecting Discontinuities Parallel to the Weld . . . . .	63
29	Pie Gauge . . . . .	63
30	Fluorescent Penetrant Technique . . . . .	65
31	IQI (Penetrameter) Common Hole Diameters . . . . .	68
32	IQI (Penetrameter) . . . . .	69
33	Single-wall Techniques . . . . .	70
34	Double-wall Techniques . . . . .	71
35	Incomplete or Lack of Penetration (LOP) . . . . .	74
36	Interpass Slag Inclusions . . . . .	74
37	Cluster Porosity . . . . .	75
38	Lack of Side Wall Fusion . . . . .	75
39	Elongated Slag (Wagon Tracks) . . . . .	76
40	Burn-through . . . . .	76
41	Offset or Mismatch with Lack of Penetration (LOP) . . . . .	77
42	Excessive Penetration (Icicles, Drop-through) . . . . .	77
43	Internal (Root) Undercut . . . . .	78
44	Transverse Crack . . . . .	78
45	Tungsten Inclusions . . . . .	79
46	Root Pass Aligned Porosity . . . . .	79
47	A-scan . . . . .	80
48	B-scan . . . . .	80
49	C-scan . . . . .	81
50	D-scan . . . . .	82
51	S-scan . . . . .	83
52	TOFD D-scan Display . . . . .	84
53	TOFD B-scan . . . . .	84
54	TOFD Transducer Arrangement and Ultrasonic Energy Beam Propagation . . . . .	85
55	DAC Curve for a Specified Reference Reflector . . . . .	87
56	DAC Curve for an Unknown Reflector . . . . .	88
57	Location of Hardness Measurements . . . . .	91

<b>A.1</b>	<b>Joint Types and Applicable Welds</b>	<b>.115</b>
<b>A.2</b>	<b>Symbols for Various Weld Joint</b>	<b>.116</b>
<b>A.3</b>	<b>Supplementary Symbols for Welds</b>	<b>.116</b>
<b>A.4</b>	<b>Standard Weld Symbols</b>	<b>.117</b>
<b>A.5</b>	<b>Groove Weld Nomenclature</b>	<b>.118</b>
<b>A.6</b>	<b>SMAW Welding Electrode Identification System</b>	<b>.118</b>
<b>A.7</b>	<b>GMAW/GTAW/PAW Welding Electrode Identification System</b>	<b>.118</b>
<b>A.8</b>	<b>FCAW Welding Electrode Identification System</b>	<b>.119</b>
<b>A.9</b>	<b>SAW Welding Electrode Identification System</b>	<b>.119</b>
<b>A.10</b>	<b>EGW Welding Electrode Identification System</b>	<b>.119</b>
<b>B.1</b>	<b>Suggested Actions for Welds Made by an Incorrect Welder</b>	<b>120</b>
<b>B.2</b>	<b>Steps to Address Production Welds Made by an Improper Welding Procedure</b>	<b>121</b>
<b>C.1a</b>	<b>Sample WPS #CS-1, Page 1 of 2</b>	<b>124</b>
<b>C.1b</b>	<b>Sample WPS #CS-1, Page 2 of 2</b>	<b>125</b>
<b>C.2a</b>	<b>Sample PQR #CS-1, Page 1 of 2</b>	<b>126</b>
<b>C.2b</b>	<b>Sample PQR #CS-1, Page 2 of 2</b>	<b>127</b>
<b>C.3a</b>	<b>Shielded Metal-Arc Welding (SMAW) Checklist, Page 1 of 2</b>	<b>128</b>
<b>C.3b</b>	<b>Shielded Metal-Arc Welding (SMAW) Checklist, Page 2 of 2</b>	<b>129</b>
<b>C.4a</b>	<b>Example of Completed Shielded Metal-Arc Welding (SMAW) Checklist, Page 1 of 2</b>	<b>131</b>
<b>C.4b</b>	<b>Example of Completed Shielded Metal-Arc Welding (SMAW) Checklist, Page 2 of 2</b>	<b>132</b>

#### Tables

<b>1</b>	<b>P-Number Assignments</b>	<b>45</b>
<b>2</b>	<b>Common Types of Discontinuities</b>	<b>49</b>
<b>3</b>	<b>Commonly Used NDE Methods</b>	<b>50</b>
<b>4</b>	<b>Capability of the Applicable Inspection Method for Weld Type Joints</b>	<b>51</b>
<b>5</b>	<b>Capability of the Applicable Inspection Method vs. Discontinuity</b>	<b>51</b>
<b>6</b>	<b>Discontinuities Commonly Encountered with Welding Processes</b>	<b>52</b>
<b>7</b>	<b>ASTM E94 IQIs (Penetrimeters)</b>	<b>68</b>
<b>8</b>	<b>Conditions that May Exist in a Material or Product</b>	<b>94</b>
<b>9</b>	<b>Results of Non-destructive Examination</b>	<b>94</b>
<b>10</b>	<b>Results of Application of Acceptance/Rejection Criteria</b>	<b>94</b>
<b>11</b>	<b>Brinell Hardness Limits for Steels in Refining Services</b>	<b>104</b>
<b>12</b>	<b>Weld Crack Tests</b>	<b>107</b>
<b>13</b>	<b>Hot Tapping/In-service Welding Hazards Associated with Some Particular Substances</b>	<b>111</b>
<b>D.1</b>	<b>Common Welding Consumables for SMAW of Carbon and Low-alloy Steel</b>	<b>140</b>
<b>D.2</b>	<b>Common Welding Consumables for SMAW of Carbon and Low-alloy Steel</b>	<b>141</b>
<b>D.3</b>	<b>Copper-nickel and Nickel-based Alloys</b>	<b>142</b>
<b>D.4</b>	<b>Classification Changes in Low-alloy Filler Metal Designations</b>	<b>143</b>

# Welding Processes, Inspection, and Metallurgy

## 1 Scope

This recommended practice (RP) provides guidance to the API authorized inspector on welding inspection as encountered with fabrication and repair of refinery and chemical plant equipment and piping. This RP includes descriptions of common welding processes, welding procedures, welder qualifications, metallurgical effects from welding, and inspection techniques to aid the inspector in fulfilling their role implementing API 510, API 570, API 653 and API 582. The level of learning and training obtained from this document is not a replacement for the training and experience required to be a certified welding inspector under one of the established welding certification programs such as the American Welding Society (AWS) Certified Welding Inspector (CWI), or Canadian and European equivalent schemes such as CWB, CSWIP, PCN, or EFW.

This RP does not require all welds to be inspected; nor does it require welds to be inspected to specific techniques and extent. Welds selected for inspection, and the appropriate inspection techniques, should be determined by the welding inspectors, engineers, or other responsible personnel using the applicable code or standard. The importance, difficulty, and problems that could be encountered during welding should be considered by all involved. A welding engineer should be consulted on any critical, specialized or complex welding issues.

## 2 Normative References

The following referenced documents are indispensable for the application of this document. For dated references, only the edition cited applies. For undated references, the latest edition of the referenced document (including any amendments) applies.

API 510, *Pressure Vessel Inspection Code: Maintenance, Inspection, Rating, Repair, and Alteration*

API 570, *Piping Inspection Code: Inspection, Repair, Alteration, and Rerating of In-Service Piping Systems*

API Recommended Practice 574, *Inspection Practices for Piping System Components*

API Recommended Practice 578, *Material Verification Program for New and Existing Alloy Piping Systems*

API Recommended Practice 582, *Recommended Practice and Supplementary Welding Guidelines for the Chemical, Oil, and Gas Industries*

API Standard 650, *Welded Steel Tanks for Oil Storage*

API Standard 653, *Tank Inspection, Repair, Alteration, and Reconstruction*

API Recommended Practice 2201, *Procedures for Welding or Hot Tapping on Equipment in Service*

ASME *Boiler and Pressure Vessel Code*<sup>1</sup>

B31.3, *Process Piping*

Section VIII, *Rules for Construction of Pressure Vessels*

Section IX, *Qualification Standard for Welding and Brazing Procedures, Welders, Brazers, and Welding and Brazing Operators*

Section XI, *Rules for Inservice Inspection of Nuclear Power Plant Components*

Practical Guide to ASME Section IX, *Welding Qualifications*

---

<sup>1</sup> ASME International, 3 Park Avenue, New York, New York 10016-5990, [www.asme.org](http://www.asme.org).

ASNT Central Certification Program CP-189<sup>2</sup>, *Standard for Qualification and Certification of Nondestructive Testing Personnel*

ASNT Central Certification Program SNT-TC-1A, *Personnel Qualification and Certification in Nondestructive Testing*

ASTM A106<sup>3</sup>, *Standard Specification for Seamless Carbon Steel Pipe for High-Temperature Service*

ASTM A335, *Standard Specification for Seamless Ferritic Alloy-Steel Pipe for High-Temperature Service*

ASTM A956, *Standard Test Method for Leeb Hardness Testing of Steel Products*

ASTM A1038, *Standard Practice for Portable Hardness Testing by the Ultrasonic Contact Impedance Method*

ASTM E94, *Standard Guide for Radiographic Examination*

ASTM E1316, *Standard Terminology for Nondestructive Examinations*

AWS A5.XX<sup>4</sup>, Series of Filler Metal Specifications

CASTI<sup>5</sup>, Guidebook to ASME Section IX—Welding Qualifications

EN 473<sup>6</sup>, *Qualification and Certification of NDT Personnel—General Principles*

ISO 9712<sup>7</sup>, *Non-destructive testing—Qualification and certification of personnel*

NACE SP 0472<sup>8</sup>, *Methods and Controls to Prevent In-Service Environmental Cracking of Carbon Steel Weldments in Corrosive Refining Environments*

WRC Bulletin 342<sup>9</sup>, *Stainless Steel Weld Metal: Prediction of Ferrite Content*

### **3 Terms, Definitions, and Acronyms**

#### **3.1 Terms and Definitions**

For the purposes of this document, the following definitions apply.

##### **3.1.1**

##### **ACFM**

The alternating current field measurement (ACFM) method is an electromagnetic inspection technique which can be used to detect and size surface breaking (or in some cases near surface) defects in both magnetic and non-magnetic materials.

---

<sup>2</sup> American Society for Nondestructive Testing, 1711 Arlingate Lane, P.O. Box 28518, Columbus, Ohio 43228, [www.asnt.org](http://www.asnt.org).

<sup>3</sup> ASTM International, 100 Barr Harbor Drive, West Conshohocken, Pennsylvania 19428, [www.astm.org](http://www.astm.org).

<sup>4</sup> American Welding Society, 550 NW LeJeune Road, Miami, Florida 33126, [www.aws.org](http://www.aws.org).

<sup>5</sup> CASTI Publishing, Inc. 10566, 114 Street, Edmonton, Alberta, T5H 3J7, Canada.

<sup>6</sup> European Committee for Standardization, Avenue Marnix 17, B-1000, Brussels, Belgium, [www.cen.eu](http://www.cen.eu).

<sup>7</sup> International Organization for Standardization, 1, ch. de la Voie-Creuse, Case postale 56, CH-1211, Geneva 20, Switzerland, [www.iso.org](http://www.iso.org).

<sup>8</sup> NACE International (formerly the National Association of Corrosion Engineers), 1440 South Creek Drive, Houston, Texas 77218-8340, [www.nace.org](http://www.nace.org).

<sup>9</sup> The Welding Research Council, 3 Park Avenue, 27th Floor, New York, New York 10016-5902, [www.forengineers.org](http://www.forengineers.org).

**3.1.2****actual throat**

The shortest distance between the weld root and the face of a fillet weld.

**3.1.3****air carbon arc cutting****CAC-A**

A carbon arc cutting process variation that removes molten metal with a jet of air.

**3.1.4****arc blow**

The deflection of an arc from its normal path because of magnetic forces.

**3.1.5****arc length**

The distance from the tip of the welding electrode to the adjacent surface of the weld pool.

**3.1.6****arc strike**

A discontinuity resulting from an arc, consisting of any localized remelted metal, heat-affected metal, or change in the surface profile of any metal object.

**3.1.7****arc welding****AW**

A group of welding processes that produces coalescence of work pieces by heating them with an arc. The processes are used with or without the application of pressure and with or without filler metal.

**3.1.8****autogenous weld**

A fusion weld made without filler metal.

**3.1.9****back-gouging**

The removal of weld metal and base metal from the weld root side of a welded joint to facilitate complete fusion and complete joint penetration upon subsequent welding from that side.

**3.1.10****backing**

A material or device placed against the back-side of the joint, or at both sides of a weld in welding, to support and retain molten weld metal.

**3.1.11****base metal**

The metal to be welded, often called parent metal.

**3.1.12****bevel angle**

The angle between the bevel of a joint member and a plane perpendicular to the surface of the member.

**3.1.13****burn-through**

A term for excessive visible root reinforcement in a joint welded from one side or a hole through the root bead.

**3.1.14****buttering**

One or more layers of deposited weld metal on the face of a weld preparation or surface that will be part of a welded joint.

**3.1.15****constant current power supply****cc**

An arc welding power source with a volt-ampere relationship yielding a small welding current change from a large arc voltage change.

**3.1.16****constant voltage power supply****cv**

An arc welding power source with a volt-ampere relationship yielding a large welding current change from a small voltage change.

**3.1.17****corrosion specialist**

A person, acceptable to the owner/user, who has knowledge and experience in corrosion damage mechanisms, metallurgy, materials selection, and corrosion monitoring techniques.

**3.1.18****crack**

A fracture type discontinuity characterized by a sharp tip and high ratio of length and width to opening displacement.

**3.1.19****defect**

A discontinuity or discontinuities that by nature or accumulated effect render a part or product unable to meet minimum applicable acceptance standards or specifications (e.g. total crack length). The term designates rejectability.

**3.1.20****direct current electrode negative****DCEN**

The arrangement of direct current arc welding leads in which the electrode is the negative pole and workpiece is the positive pole of the welding arc. Commonly known as straight polarity.

**3.1.21****direct current electrode positive****DCEP**

The arrangement of direct current arc welding leads in which the electrode is the positive pole and the work piece is the negative pole of the welding arc. Commonly known as reverse polarity.

**3.1.22****discontinuity**

An interruption of the typical structure of a material, such as a lack of homogeneity in its mechanical, metallurgical, or physical characteristics. A discontinuity is not necessarily a defect.

**3.1.23****distortion**

The change in shape or dimensions, temporary or permanent, of a part as a result of heating or welding.



**3.1.24****Eddy current examination technique****ET**

An inspection method that applies primarily to non-ferromagnetic materials.

**3.1.25****examiner**

A person who assists the inspector by performing specific nondestructive examination (NDE) on components but does not evaluate the results of those examinations in accordance with the appropriate inspection Code, unless specifically trained and authorized to do so by the owner or user

**3.1.26****filler metal**

The metal or alloy to be added in making a welded joint.

**3.1.27****fillet weld size**

For equal leg fillet welds, the leg lengths of the largest isosceles right triangle that can be inscribed within the fillet weld cross section.

**3.1.28****fusion line**

The interface between the base and weld metal.

**3.1.29****groove angle**

The total included angle of the groove between work pieces.

**3.1.30****heat affected zone****HAZ**

The portion of the base metal whose mechanical properties or microstructure have been altered by the heat of welding or thermal cutting.

**3.1.31****heat input**

The energy supplied by the welding arc to the work piece. Heat input is calculated as follows:

heat input =  $(V \times i \times 60) / (1000 \times v)$  in kJ/in., where  $V$  = voltage,  $i$  = amperage,  $v$  = weld travel speed (in./min).

**3.1.32****hot cracking**

Cracking formed at temperatures near the completion of solidification.

**3.1.33****inclusion**

Entrapped foreign solid material, such as slag, flux, tungsten, or oxide.

**3.1.34****incomplete fusion**

A weld discontinuity in which complete coalescence did not occur between weld metal and fusion faces or adjoining weld beads.

**3.1.35****incomplete joint penetration**

A joint root condition in a groove weld in which weld metal does not extend through the joint thickness.

**3.1.36****indication**

A signal of discontinuity in the material under nondestructive examination.

**3.1.37****inspector**

An individual who is qualified and certified to perform inspections under the proper inspection code or who holds a valid and current National Board Commission.

**3.1.38****interpass temperature, welding**

In a multipass weld, the lowest temperature of the deposited weld metal before the next weld pass is started.

**3.1.39****Image quality indicator****IQI**

“Penetrameter” is another common term for IQI.

**3.1.40****joint penetration**

The distance the weld metal extends from the weld face into a joint, exclusive of weld reinforcement.

**3.1.41****joint type**

A weld joint classification based on five basic joint configurations such as a butt joint, corner joint, edge joint, lap joint, and t-joint.

**3.1.42****lack of fusion****LOF**

A non-standard term indicating a weld discontinuity in which fusion did not occur between weld metal and fusion faces or adjoining weld beads.

**3.1.43****lamellar tear**

A subsurface terrace and step-like crack in the base metal with a basic orientation parallel to the wrought surface caused by tensile stresses in the through-thickness direction of the base metal weakened by the presence of small dispersed, planar shaped, nonmetallic inclusions parallel to the metal surface.

**3.1.44****lamination**

A type of discontinuity with separation or weakness generally aligned parallel to the worked surface of a metal.

**3.1.45****linear discontinuity**

A discontinuity with a length that is substantially greater than its width.

**3.1.46****longitudinal crack**

A crack with its major axis orientation approximately parallel to the weld axis.

**3.1.47**  
**nondestructive examination**  
**NDE**

The act of determining the suitability of some material or component for its intended purpose using techniques that do not affect its serviceability.

**3.1.48**  
**overlap**

The protrusion of weld metal beyond the weld toe or weld root.

**3.1.49**  
**oxyacetylene cutting**  
**OFA**

An oxygen fuel gas cutting process variation that uses acetylene as the fuel gas.

**3.1.50**  
**peening**

The mechanical working of metals using impact blows.

**3.1.51**  
**penetrameter**

Old terminology for IQI still in use today but not recognized by the codes and standards.

**3.1.52**  
**porosity**

Cavity-type discontinuities formed by gas entrapment during solidification or in thermal spray deposit.

**3.1.53**  
**positive material identification testing**  
**PMI testing**

Any physical evaluation or test of a material to confirm that the material which has been or will be placed into service is consistent with the selected or specified alloy material designated by the owner/user.

**3.1.54**  
**preheat**

Metal temperature value achieved in a base metal or substrate prior to initiating the thermal operations. Also equal to the minimum interpass temperature.

**3.1.55**  
**procedure qualification record**  
**PQR**

A record of the welding data and variables used to weld a test coupon and the test results used to qualify the welding procedure.

**3.1.56**  
**recordable indication**

Recording on a data sheet of an indication or condition that does not necessarily exceed the rejection criteria but in terms of code, contract or is documented.

**3.1.57**  
**reportable indication**

Recording on a data sheet of an indication that exceeds the reject flaw size criteria and needs not only documentation, but also notification to the appropriate authority to be corrected. All reportable indications are recordable indications but not vice-versa.

**3.1.58****root face**

The portion of the groove face within the joint root.

**3.1.59****root opening**

A separation or gap at the joint root between the work pieces.

**3.1.60****shielding gas**

Protective gas used to prevent or reduce atmospheric contamination.

**3.1.61****slag**

A nonmetallic product resulting from the mutual dissolution of flux and nonmetallic impurities in some welding and brazing processes.

**3.1.62****slag inclusion**

A discontinuity consisting of slag entrapped in the weld metal or at the weld interface.

**3.1.63****spatter**

The metal particles expelled during fusion welding that do not form a part of the weld.

**3.1.64****tack weld**

A weld made to hold the parts of a weldment in proper alignment until the final welds are made.

**3.1.65****temper bead welding**

A welding technique where the heat and placement of weld passes in deposited weld layers is controlled so that sufficient heat is provided to temper each previously deposited weld layer.

**3.1.66****throat theoretical**

The distance from the beginning of the joint root perpendicular to the hypotenuse of the largest right triangle that can be inscribed within the cross-section of a fillet weld. This dimension is based on the assumption that the root opening is equal to zero

**3.1.67****transverse crack**

A crack with its major axis oriented approximately perpendicular to the weld axis.

**3.1.68****travel angle**

The angle less than 90 degrees between the electrode axis and a line perpendicular to the weld axis, in a plane determined by the electrode axis and the weld axis.

**3.1.69****tungsten inclusion**

A discontinuity consisting of tungsten entrapped in weld metal.

**3.1.70****undercut**

A groove melted into the base metal adjacent to the weld toe or weld root and left unfilled by weld metal.

**3.1.71****underfill**

A condition in which the weld joint is incompletely filled when compared to the intended design.

**3.1.72****welder**

A person who performs a manual or semiautomatic welding operation.

**3.1.73****welder certification**

Written verification that a welder has produced welds meeting a prescribed standard of welder performance.

**3.1.74****welder performance qualification****WPQ**

A test administered to a welder to demonstrate the welder's ability to produce welds meeting prescribed standards. Welding performance qualification tests are specific to a WPS.

**3.1.75****welding**

A joining process that produces coalescence of base metals by heating them to the welding temperature, with or without the application of pressure or by the application of pressure alone, and with or without the use of filler metal.

**3.1.76****welding engineer**

An individual who holds an engineering degree and is knowledgeable and experienced in the engineering disciplines associated with welding.

**3.1.77****welding operator**

A person who operates automatic welding equipment.

**3.1.78****welding procedure specification****WPS**

A document that describes how welding is to be carried out in production.

**3.1.79****weldment**

An assembly whose component parts are joined by welding.

**3.1.80****weld joint**

The junction of members or the edges of members which are to be joined or have been joined by welding.

**3.1.81****weld reinforcement**

Weld metal in excess of the quantity required to fill a joint.

**3.1.82****weld toe**

The junction of the weld face and the base metal.

**3.1.83****wet fluorescent magnetic-particle examination technique****WFMT**

This inspection method is suitable for magnetic materials.

**3.2 Acronyms**

LT	leak examination technique
MT	magnetic Particle examination technique
PT	penetrant examination technique.
RT	radiographic examination technique.
VT	visual examination technique.

**4 Welding Inspection****4.1 General**

Welding inspection is a critical part of an overall weld quality assurance program. Welding inspection includes much more than just the non-destructive examination of the completed weld. Many other issues are important, such as review of specifications, joint design, cleaning procedures, and welding procedures. Welder qualifications should be performed to better assure the weldment performs properly in service.

Welding inspection activities can be separated into three stages corresponding to the welding work process. Inspectors should perform specific tasks prior to welding, during welding and upon completion of welding, although it is usually not necessary to inspect every weld.

**4.2 Tasks Prior to Welding**

The importance of tasks in the planning and weld preparation stage should not be understated. Many welding problems can be avoided during this stage when it is easier to make changes and corrections, rather than after the welding is in progress or completed. Such tasks may include.

**4.2.1 Drawings, Codes, and Standards**

Review drawings, standards, codes, and specifications to both understand the requirements for the weldment and identify any inconsistencies.

**4.2.1.1 Quality Control Items To Assess**

Items that should be reviewed on drawings, Codes, and Standards include the following.

- a) Welding symbols and weld sizes clearly specified (see Annex A).
- b) Weld joint designs and dimensions clearly specified (see Annex A).
- c) Weld maps identify the welding procedure specification (WPS) to be used for specific weld joints.
- d) Dimensions detailed and potential for distortion addressed.

- e) Welding consumables specified (see 7.3, 7.4, 7.6, and Annex D).
- f) Proper handling of consumables, if any, identified (see 7.7).
- g) Base material requirements specified (such as the use of impact tested materials where notch ductility is a requirement in low temperature service).
- h) Mechanical properties and required testing identified (see 10.4).
- i) Weather protection and wind break requirements defined.
- j) Preheat requirements and acceptable preheat methods defined (see 10.5).
- k) Postweld heat treatment (PWHT) requirements and acceptable PWHT method defined (see 10.6).
- l) Inspection hold-points and NDE requirements defined (see Section 9).
- m) Additional requirements, such as production weld coupons, clearly specified.
- n) Pressure testing requirements, if any, clearly specified (see 9.11).

#### **4.2.1.2 Potential Inspector Actions**

Actions for the inspector to review on drawings, Codes, and Standards include the following.

- a) Identify and clarify missing details and information.
- b) Identify and clarify missing weld sizes, dimensions, tests, and any additional requirements.
- c) Identify and clarify inconsistencies with standards, codes, and specification requirements.
- d) Highlight potential weld problems not addressed in the design.
- e) Establish applicable accept/reject criteria.
- f) Verify that the appropriate degree of NDE has been specified.

#### **4.2.2 Weldment Requirements**

Review requirements for the weldment with the personnel involved with executing the work such as the design engineer, welding engineer, welding organization and inspection organization.

##### **4.2.2.1 Quality Control Items To Assess**

Welding requirement quality control items that should be reviewed are as follows.

- a) Competency of welding organization to perform welding activities in accordance with codes, standards, and specifications.
- b) Competency of inspection organization to perform specified inspection tasks.
- c) Roles and responsibilities of engineers, welding organization, and welding inspectors defined and appropriate for the work.

- d) Independence of the inspection organization from the production organization is clear and demonstrated.
- e) Competency of welding organization to perform welder/welding operator qualifications.

#### **4.2.2.2 Potential Inspector Action**

Highlight deficiencies and concerns with the organizations to appropriate personnel.

#### **4.2.3 Procedures and Qualification Records**

Review the WPS(s) and welder performance qualification record(s) (WPQ) to assure they are acceptable for the work.

##### **4.2.3.1 Quality Control Items To Assess**

Welding procedure and qualification records that should be reviewed include the following.

- a) WPS(s), including those developed for making repairs, are properly qualified and meet applicable codes, standards and specifications for the work (see 6.4).
- b) Procedure qualification records (PQR) are properly performed and support the WPS(s) (see 6.4).
- c) Welder performance qualifications (WPQ) meet requirements for the WPS (see 8.3).

##### **4.2.3.2 Potential Inspector Actions**

Actions for the inspector to review on welding procedure and qualification records include the following.

- a) Obtain acceptable WPS(s) and PQR(s) for the work.
- b) Qualify WPS(s) where required and witness qualification effort.
- c) Qualify or re-qualify welders where required and witness a percentage of the welder qualifications.

#### **4.2.4 NDE Information**

Confirm the NDE examiner(s), NDE procedure(s) and NDE equipment of the inspection organization are acceptable for the work.

##### **4.2.4.1 Quality Control Items To Assess**

NDE information that should be reviewed includes the following.

- a) NDE examiners are properly certified for the NDE technique (see 4.6).
- b) NDE procedures are current and accurate.
- c) Calibration of NDE equipment is current.
- d) NDE procedures and techniques specified are capable of achieving the required acceptance/rejection requirements.



#### **4.2.4.2 Potential Inspector Actions**

Actions for the inspector to review on NDE information include the following.

- a) Identify and correct deficiencies in certifications and procedures.
- b) Obtain calibrated equipment.

#### **4.2.5 Welding Equipment and Instruments**

Confirm welding equipment and instruments are calibrated and operable.

##### **4.2.5.1 Quality Control Items To Assess**

Items that should be reviewed on welding equipment and instruments include the following.

- a) Welding machine calibration is current.
- b) Instruments such as ammeters, voltmeters, contact pyrometers, have current calibrations.
- c) Storage ovens for welding consumables operate with automatic heat control and visible temperature indication.

##### **4.2.5.2 Potential Inspector Actions**

Actions for the inspector to review on welding equipment and instruments include the following.

- a) Confirm recalibration of equipment and instruments.
- b) Confirm replacement of defective equipment and instruments.

#### **4.2.6 Heat Treatment and Pressure Testing**

Confirm heat treatment and pressure testing procedures and associated equipment are acceptable.

##### **4.2.6.1 Quality Control Items To Assess**

Heat treatment and pressure testing items that should be reviewed include the following.

- a) Heat treatment procedure is available and appropriate (see 10.6).
- b) Pressure testing procedures are available and detail test requirements (see 9.11).
- c) PWHT equipment calibration is current.
- d) Pressure testing equipment and gauges calibrated and meet appropriate test requirements.

##### **4.2.6.2 Potential Inspector Actions**

Actions for the inspector to review on heat treatment and pressure testing equipment and procedures include the following.

- a) Identify and correct deficiencies in procedures.
- b) Obtain calibrated equipment.

## **4.2.7 Materials**

Ensure all filler metals, base materials, and backing ring materials are properly marked and identified and if required, perform PMI to verify the material composition.

### **4.2.7.1 Quality Control Items To Assess**

Details that should be reviewed on materials used during welding include the following.

- a) Material test certifications are available and items properly marked (including backup ring if used; see 10.8).
- b) Electrode marking, bare wire flag tags, identification on spools of wire, etc. as-specified (see 9.2).
- c) Filler material markings are traceable to a filler material certification.
- d) Base metal markings are traceable to a material certification.
- e) Recording of filler and base metal traceability information is performed.
- f) Base metal stampings are low stress and not detrimental to the component.
- g) Paint striping color code is correct for the material of construction.
- h) PMI records supplement the material traceability and confirm the material of construction (see 9.2).

### **4.2.7.2 Potential Inspector Actions**

Actions for the inspector to review on materials used during welding include the following.

- a) Reject non-traceable or improperly marked materials.
- b) Reject inappropriate materials.

## **4.2.8 Weld Preparation**

Confirm weld preparation, joint fit-up, and dimensions are acceptable and correct.

### **4.2.8.1 Quality Control Items To Assess**

Details related to weld preparation that should be reviewed include the following.

- a) Weld preparation surfaces are free of contaminants and base metal defects such as laminations and cracks.
- b) Preheat, if required, applied for thermal cutting.
- c) Hydrogen bake-out heat treatment, if required, performed to procedure.
- d) Weld joint is free from oxide and sulfide scales, hydrocarbon residue, and any excessive build-up of weld-through primers.
- e) Weld joint type, bevel angle, root face, and root opening are correct.
- f) Alignment and mismatch is correct and acceptable.

- g) Dimensions of base materials, filler metal, and weld joint are correct.
- h) Piping socket welds have proper gap.

#### **4.2.8.2 Potential Inspector Action**

Reject material or correct deficiencies.

#### **4.2.9 Preheat**

Confirm the preheat equipment and temperature.

##### **4.2.9.1 Quality Control Items To Assess**

Preheat equipment and preheat temperature that should be reviewed include the following.

- a) Preheat equipment and technique are acceptable.
- b) Preheat coverage and temperature are correct (see 10.5).
- c) Reheat, if required, applied to thermal cutting operations.
- d) Preheat, if required, applied to remove moisture.

##### **4.2.9.2 Potential Inspector Action**

Identify and correct deficiencies in the preheat operations.

#### **4.2.10 Welding Consumables**

Confirm electrode, filler wire, fluxes, and inert gases are as specified and acceptable.

##### **4.2.10.1 Quality Control Items To Assess**

Details related to welding consumables that should be reviewed include the following.

- a) Filler metal type and size are correct per procedure.
- b) Filler metals are being properly handled and stored (see 7.7).
- c) Filler metals are clean and free of contaminants.
- d) Coating on coated electrodes is neither damaged nor wet.
- e) Flux is appropriate for the welding process and being properly handled.
- f) Inert gases, if required are appropriate for shielding and purging.
- g) Gas composition is correct and meets purity requirements.
- h) Shielding gas and purging manifold systems are periodically bled to prevent back filling with air.

#### **4.2.10.2 Potential Inspector Actions**

Actions for the inspector to review on welding consumables include the following.

- a) Reject inappropriate materials.
- b) Identify and correct deficiencies.

### **4.3 Tasks During Welding Operations**

Welding inspection during welding operations should include audit parameters to verify the welding is performed to the procedures. Such tasks may include the following.

#### **4.3.1 Quality Assurance**

Establish a quality assurance and quality control audit procedure with the welding organization.

##### **4.3.1.1 Quality Control Items To Assess**

Details on welding quality assurance and quality control audit procedures that should be reviewed include the following.

- a) Welder is responsible for quality craftsmanship of weldments.
- b) Welder meets qualification requirements.
- c) Welder understands welding procedure and requirements for the work.
- d) Special training and mock-up weldments performed if required.
- e) Welder understands the inspection hold-points.

##### **4.3.1.2 Potential Inspector Actions**

Actions for the inspector to review related to welding quality assurance and quality control audit procedures include

- a) Review welder performance with welding organization.
- b) See Annex B.

#### **4.3.2 Welding Parameters and Techniques**

Confirm welding parameters and techniques are supported by the WPS and WPQ.

##### **4.3.2.1 Quality Control Items To Assess**

Details related to welding parameters and welding technique that should be reviewed includes the following.

- a) Essential variables are being met during welding.
  - 1) Filler material, fluxes, and inert gas composition/flow rate.
  - 2) Purge technique, flow rate, O<sub>2</sub> analysis, etc.

- 3) Rod warmers energized or where rod warmers are not employed, the welder complies with maximum exposure times out of the electrode oven.
  - 4) Preheating during tack welding and tack welds removed (if required).
  - 5) Welding technique, weld progression, bead overlap, etc.
  - 6) Equipment settings such as amps, volts, and wire feed.
  - 7) Preheat and interpass temperatures. As detailed in API 582, the maximum interpass temperature should be specified for austenitic stainless steels, duplex stainless steels, and non-ferrous alloys (i.e. Type-300 stainless steels). The maximum interpass temperature should also be specified for carbon/low alloy steels that require impact testing.
  - 8) Travel speed (key element in heat input).
  - 9) Heat input (where appropriate).
- b) Mock-up weldment which simulates the production weld joint, meets requirements of the welding engineer and is used to demonstrate welder capability or weld procedure parameters as required.
  - c) Welder adheres to good welding practices.

#### **4.3.2.2 Potential Inspector Actions**

Actions for the inspector to review related to welding parameters and welding technique includes the following.

- a) Review mock-up weldment problems with welding engineer.
- b) Review weld quality with welding organization.
- c) See Annex B.

#### **4.3.3 Weldment Examination**

Complete physical checks, visual examination, and in-process NDE.

##### **4.3.3.1 Quality Control Items To Assess**

Details related to examination of the weldment that should be reviewed includes the following.

- a) Tack welds to be incorporated in the weld are of acceptable quality.
- b) Weld root has adequate penetration and quality.
- c) Cleaning between weld passes and of back-gouged surfaces is acceptable.
- d) Additional NDE performed between weld passes and on back-gouged surfaces shows acceptable results.
- e) In-process rework and defect removal is accomplished.
- f) In-process ferrite measurement, if required, is performed and recorded.
- g) Final weld reinforcement and fillet weld size meets work specifications and drawings.

#### **4.3.3.2 Potential Inspector Action**

Reject unacceptable workmanship.

### **4.4 Tasks Upon Completion of Welding**

Final tasks upon completion of the weldment and work should include those that assure final weld quality before placing the weldment in service.

#### **4.4.1 Appearance and Finish**

Verify postweld acceptance, appearance and finishing of the welded joints.

##### **4.4.1.1 Quality Control Items To Assess**

Details related to weld appearance and finish that should be reviewed includes the following.

- a) Size, length and location of all welds conform to the drawings/specifications/code.
- b) No welds added without approval.
- c) Dimensional and visual checks of the weld don't identify welding discontinuities, excessive distortion, and poor workmanship.
- d) Temporary attachments and attachment welds removed and blended with base metal.
- e) Discontinuities reviewed against acceptance criteria for defect classification.
- f) PMI of the weld, if required, indicating compliance with the specification.
- g) Welder stamping/markings of welds confirmed.
- h) Perform field hardness check (see 9.10).

##### **4.4.1.2 Potential Inspector Actions**

Inspect rework of existing welds, removal of welds and weld repairs made as required.

#### **4.4.2 NDE Review**

Verify NDE is performed at selected locations and review examiner's findings.

##### **4.4.2.1 Quality Control Items To Assess**

Details related to NDE that should be reviewed includes the following.

- a) Specified locations examined.
- b) Specified frequency of examination.
- c) NDE performed after final PWHT.
- d) Work of each welder included in random examination techniques.

- e) RT film quality, IQI placement, IQI visibility, etc. complies with standards.
- f) Inspector is in agreement with examiners interpretations and findings.
- g) Documentation for all NDE correctly executed (see 9.11).

#### **4.4.2.2 Potential Inspector Actions**

Actions for the inspector to review related to NDE includes the following.

- a) Require additional NDE to address deficiencies in findings.
- b) Check joints for delayed cracking of thick section, highly constrained and high strength material joining.
- c) Repeat missing or unacceptable examinations.
- d) Correct discrepancies in examination records.

#### **4.4.3 Postweld Heat Treatment**

Verify postweld heat treatment is performed to the procedure and produces acceptable results.

##### **4.4.3.1 Quality Control Items To Assess**

Details related to postweld heat treatment that should be reviewed includes the following.

- a) Paint marking and other detrimental contamination removed.
- b) Temporary attachments removed.
- c) Machined surfaces protected from oxidation.
- d) Equipment internals, such as valve internals, removed to prevent damage.
- e) Equipment supported to prevent distortion.
- f) Thermocouples fastened properly.
- g) Thermocouples adequately monitor the different temperature zones and thickest/thinnest parts in the fabrication.
- h) Temperature monitoring system calibrated.
- i) Local heating bandwidth is adequate.
- j) Insulation applied to the component where required for local heating.
- k) Temperature and hold time are correct.
- l) Heating rate and cooling rate are correct.
- m) Distortion is acceptable after completion of the thermal cycle.
- n) Hardness indicates an acceptable heat treatment (see 10.7).

#### **4.4.3.2 Potential Inspector Actions**

Actions for the inspector to review related to postweld heat treatment includes the following.

- a) Calibrate temperature-monitoring equipment.
- b) Correct deficiencies before heat treatment.
- c) Repeat the heat treatment cycle.

#### **4.4.4 Pressure Testing**

Verify pressure test is performed to the procedure.

##### **4.4.4.1 Quality Control Items To Assess**

Details related to pressure testing that should be reviewed includes the following.

- a) Pressure meets test specification.
- b) Test duration is as specified.
- c) Metal temperature of component meets minimum and maximum requirements.
- d) Pressure drop or decay is acceptable per procedure.
- e) Visual examination does not reveal defects.

##### **4.4.4.2 Potential Inspector Actions**

Actions for the inspector to review related to pressure testing includes the following.

- a) Either correct deficiencies prior to or during pressure test as appropriate.
- b) Repeat test as necessary.
- c) Approve repair plan if defects are identified.

#### **4.4.5 Documentation Audit**

Perform a final audit of the inspection dossier to identify inaccuracies and incomplete information.

##### **4.4.5.1 Quality Control Items To Assess**

Details related to the inspection dossier that should be reviewed includes the following.

- a) All verifications in the quality plan were properly executed.
- b) Inspection reports are complete, accepted and signed by responsible parties.
- c) Inspection reports, NDE examiners interpretations and findings are accurate (see 9.11).



#### 4.4.5.2 Potential Inspector Actions

Actions for the inspector to review related to the inspection dossier includes the following.

- a) Require additional inspection verifications to address deficiencies in findings.
- b) Repeat missing or unacceptable examinations.
- c) Correct discrepancies in examination records.

### 4.5 Non-Conformances and Defects

#### 4.5.1 General

At any time during the welding inspection, if defects or non-conformances to the specification are identified, they should be brought to the attention of those responsible for the work or corrected before welding proceeds further. Defects should be completely removed and re-inspected following the same tasks outlined in this section until the weld is found to be acceptable. Corrective action for a non-conformance depends upon the nature of the non-conformance and its impact on the properties of the weldment. Corrective action may include reworking the weld. See 9.1 for common types of discontinuities or flaws that can lead to defects or non-conformances.

#### 4.5.2 Repair Welds

When inspection identifies a rejectable defect, the inspector should mark the area for repair, the defect removed, and any necessary repair welding performed. Any repair welding should be performed according to a procedure accepted by the inspector or engineer. After the repair, the weld should be reinspected. If the inspection indicates that the repair is acceptable, no further action is taken, and the equipment/piping is placed into service. If the inspection indicates that the defect was not removed or that a new defect is present, the repair weld is rejected and a second repair is undertaken. After the second unsuccessful attempt at weld repair, the inspector and/or welding engineer should evaluate the reason for the inadequacy of the weld repair.

There are many factors that come into play when trying to determine the number of times a welded joint can continuously be repaired before a complete cut-out of the weld is required such as: base metal material, complexity of the weld configuration/position (e.g. furnace tubes or boiler tubes), or size of the weld. The welding engineer or inspector should be notified when a weld has failed a weld quality test more than three times to help determine the cause(s) of the defect(s) and the appropriate path forward.

### 4.6 NDE Examiner Certification

**4.6.1** The referencing codes or standards may require the examiner be qualified in accordance with a specific code and certified as meeting the requirements. Typically weld construction standards such as ASME for pressure vessels or piping, and API 510 for in-service pressure vessel examination reference ASME Section V, Article 1, which when specified by the referencing code, requires NDE personnel be qualified with one of the following:

- a) ASNT SNT-TC-1A,
- b) ANSI/ASNT CP-189.

These references give the employer guidelines (SNT-TC-1A) or standards (CP-189) for the certification of NDE inspection personnel. They also require the employer to develop and establish a written practice or procedure that details the employer's requirements for certification of inspection personnel. It typically includes the training, and experience prerequisites prior to certification, and recertification requirements. A certification scheme in accordance with ISO 9712 may be specified for international work. ISO 9712 outlines certification guidelines generally organized under a national scheme and vested in the individual. In the USA the scheme is managed by ASNT as the ACCP

(ASNT Central Certification Program). Although an Inspection company's Written Practice may allow the employer to appoint a Level III, the owner user may prefer that, at least for initial certification, a Level III Examiner be certified by examination.

**4.6.2** If the referencing code does not list a specific standard to be qualified against, qualification may involve demonstration of competency by the personnel performing the examination or other requirements specified by the owner-user. The API in-service inspection documents go further than this and for a number of specific circumstances such as fitness-for-service (FFS) and welds not subject to hydrotest may require the use of personnel who have passed a performance test such as the API QUTE (Qualification of Ultrasonic Examiners) or owner-user accepted equivalent.

**4.6.3** Equivalency is determined by the relevant API committee and is posted on the API website. In general it is defined as:

Ultrasonic shear wave operators should be subject to a performance demonstration test that should meet or exceed as a minimum the test protocols, criteria and passing scores described as follows.

- a) The test should be administered either by the owner-user or an independent third party as designated by the owner-user. All testing protocols including design, manufacture, and verification of test samples should be documented and retained under close limited supervision to ensure the test protocols remain confidential.
- b) Candidates prior to performance testing should demonstrate training and certification to a national or international certification scheme acceptable to the owner-user (see SNT-TC-1A, CP-189, EN473, or ISO 9712 for guidance).
- c) Candidates should be provided with a written outline protocol which they should read and acknowledge prior to commencement of the test.
- d) As a minimum the test should comprise:
  - 1) Carbon steel (P1) plates  $\frac{1}{2}$  in. (12 mm) and 1 in. (25 mm) thick with a weld with a single or double 'V' weld prep.
  - 2) Two carbon steel (P1) pipes 12 in. (300 mm) and 8 in. (200 mm) NPS, in the wall thickness range  $\frac{1}{2}$  in. to  $\frac{3}{4}$  in. (12 mm to 17 mm).
  - 3) The samples should provide a weld length such that the total weld length examined by the candidate should not be less than 77 in. (1956 mm) in total.
  - 4) The total weld length should include a number of individual flaws simulating the following typical weld imperfections:
    - i) lack of side wall fusion;
    - ii) lack of root fusion;
    - iii) linear inclusions (slag);
    - iv) cracks;
    - v) porosity.
- e) Flaws should be designed and placed so as to determine the candidate's ability to detect and characterize a flaw, and to accurately locate the flaw in relationship to the weld. Also, the individual should demonstrate the ability to discern geometric indications like mismatch and weld root from actual flaws.

**4.6.4** In order to be successful in the test, candidates should detect, characterize and locate 80 % of the known flaws in the weld sections they have been requested to examine. Candidates who make more than 20 % overcalls i.e. misinterpreting a geometric reflector as a flaw should not be deemed to have passed the test.

**4.6.5** Candidates should be advised if they have passed or failed the test. No other data should be made available in order to ensure the confidentiality of data relating to flaw, numbers, locations, types, and sizes.

**4.6.6** The approval test should typically be valid for a period of three years after which the candidate should be retested. If at any time the performance of an operator is called into question, the operator may be re-tested at the owner-users discretion.

**4.6.7** Approval of any candidate under this protocol is restricted to the specific owner-user administering the test and it should be utilized for compliance with the referenced paragraphs in API 510 and API 570 and should not be deemed as an API certification or endorsement in any form.

## **4.7 Safety Precautions**

Inspectors should be aware of the hazards associated with welding and take appropriate steps to prevent injury while performing inspection tasks. As a minimum, the site's safety rules and regulations should be reviewed as applicable to welding operations. Hazards that the inspector would more commonly encounter in the presence of welding include arc radiation, air contamination, airborne debris, tripping hazards (cables), and heat. The arc is a source of visible, ultraviolet and infrared light. As such, eye protection using proper filters and proper clothing to cover the skin should be used. Proper ventilation is necessary to remove air-borne particulates, which include vaporized metals. In areas of inadequate ventilation, filtered breathing protection may be required. The use of gas-shielded processes in confined spaces can create an oxygen deficient environment. Ventilation practice in these instances should be carefully reviewed. Welding can produce sparks and other air-borne debris that can burn the eyes. Appropriate precautions are necessary.

## **5 Welding Processes**

### **5.1 General**

The inspector should understand the basic arc welding processes most frequently used in the fabrication and repair of refinery and chemical process equipment. These processes include shielded metal arc welding (SMAW), gas tungsten arc welding (GTAW), gas metal arc welding (GMAW), flux cored arc welding (FCAW), submerged arc welding (SAW), stud welding (SW), plasma arc welding (PAW), and electrogas welding (EGW). Descriptions of less frequently used welding process are available in the referenced material. Each process has advantages and limitations depending upon the application and can be more or less prone to particular types of discontinuities.

### **5.2 Shielded Metal Arc Welding (SMAW)**

#### **5.2.1 General**

SMAW is the most widely used of the various arc welding processes. SMAW uses an arc between a covered electrode and the weld pool. It employs the heat of the arc, coming from the tip of a consumable covered electrode, to melt the base metal. Shielding is provided from the decomposition of the electrode covering, without the application of pressure and with filler metal from the electrode. Either alternating current (ac) or direct current (dc) may be employed, depending on the welding power supply and the electrode selected. A constant-current (CC) power supply is preferred. SMAW is a manual welding process. See Figure 1 and Figure 2 for schematics of the SMAW circuit and welding process.

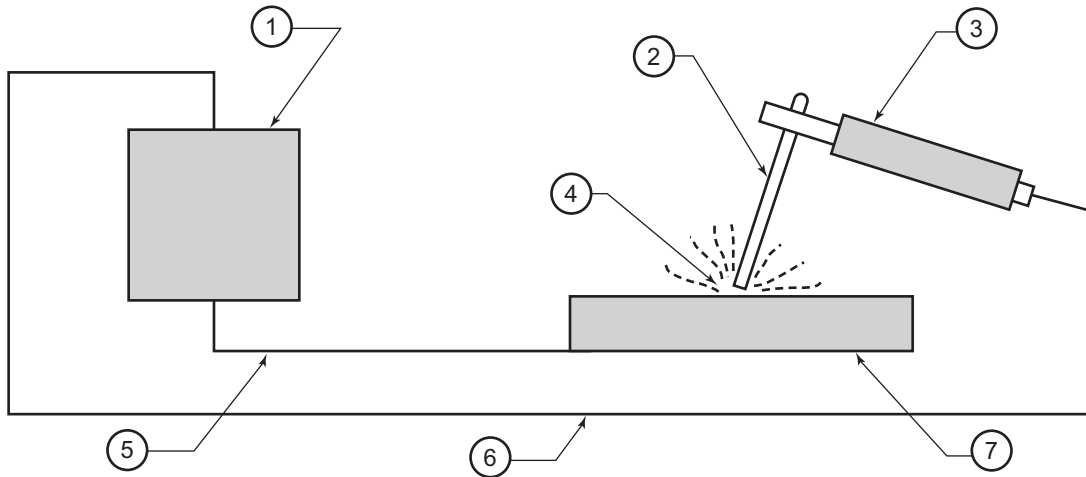

- Key**
- 1 AC or DC power source and controls
  - 2 electrode
  - 3 electrode holder
  - 4 arc
  - 5 workpiece lead
  - 6 electrode lead
  - 7 workpiece

*From Jefferson's Welding Encyclopedia, 18th Edition, Reprinted Courtesy of AWS.*

**Figure 1—SMAW Welding**

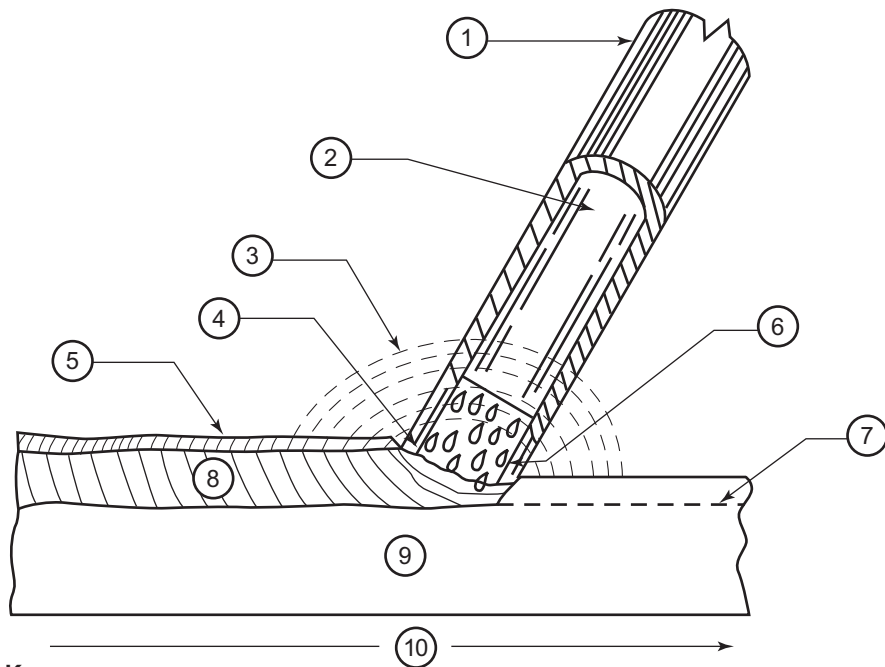

- Key**
- 1 electrode covering
  - 2 core wire
  - 3 shielding atmosphere
  - 4 weld pool
  - 5 solidified slag
  - 6 metal and slag droplets
  - 7 penetration depth
  - 8 weld metal
  - 9 base metal
  - 10 direction of welding

*From Jefferson's Welding Encyclopedia, 18th Edition, Reprinted Courtesy of AWS.*

**Figure 2—SMAW Welding Electrode During Welding**

## 5.2.2 Electrode Covering

Depending on the type of electrode being used, the covering performs one or more of the following functions.

- a) Provides a gas to shield the arc and prevent excessive atmospheric contamination of the molten filler metal.
- b) Provides scavengers, deoxidizers, and fluxing agents to cleanse the weld and prevent excessive grain growth in the weld metal.
- c) Establishes the electrical characteristics of the electrode, stabilizes the welding arc and influences operability in various welding positions.
- d) Provides a slag blanket to protect the hot weld metal from the air and enhances the mechanical properties, bead shape, and surface cleanliness of the weld metal.
- e) Provides a means of adding alloying elements to produce appropriate weld metal chemistry, mechanical properties and increase deposition efficiency.

## 5.2.3 Advantages of SMAW

Some commonly accepted advantages of the SMAW process include:

- a) Equipment is relatively simple, inexpensive, and portable.
- b) Process can be used in areas of limited access.
- c) Process is less sensitive to wind and draft than other welding processes.
- d) Process is suitable for most of the commonly used metals and alloys.

## 5.2.4 Limitations of SMAW

Limitations associated with SMAW are:

- a) Deposition rates are lower than for other processes such as GMAW.
- b) Slag usually must be removed from every deposited weld pass, at stops and starts, and before depositing a weld bead adjacent to or onto a previously deposited weld bead.

## 5.3 Gas Tungsten Arc Welding (GTAW)

### 5.3.1 General

GTAW is an arc welding process that uses an arc between a non-consumable tungsten electrode and the weld pool. The process is commonly referred to as TIG (tungsten inert gas) or heliarc welding, and is used with a shielding gas and without the application of pressure. GTAW can be used with or without the addition of filler metal. The constant current (CC) type power supply can be either dc or ac, and depends largely on the metal to be welded. Direct current welding is typically performed with the electrode negative (DCEN) polarity. DCEN welding offers the advantages of deeper penetration and faster welding speeds. Alternating current provides a cathodic cleaning (sputtering) that removes refractory oxides from the surfaces of the weld joint, which is necessary for welding aluminum and magnesium. The cleaning action occurs during the portion of the ac wave, when the electrode is positive with respect to the work piece. See Figure 3 and Figure 4 for schematics of the GTAW equipment and welding process.

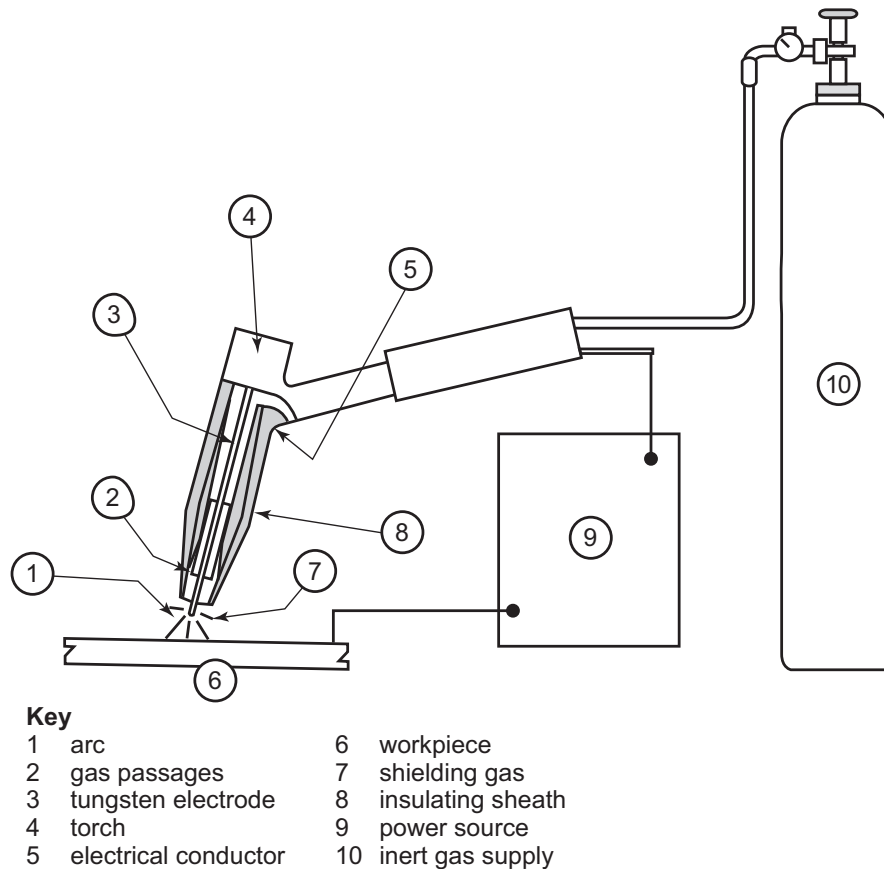

*From Jefferson's Welding Encyclopedia, 18th Edition, Reprinted Courtesy of AWS.*

**Figure 3—GTAW Welding Equipment**

### 5.3.2 Advantages of GTAW

Some commonly accepted advantages of the GTAW process include:

- a) produces high purity welds, generally free from defects;
- b) little postweld cleaning is required;
- c) allows for excellent control of root pass weld penetration;
- d) can be used with or without filler metal, dependent on the application.

### 5.3.3 Limitations of GTAW

Limitations associated with GTAW process are:

- a) deposition rates are lower than the rates possible with consumable electrode arc welding processes;
- b) has a low tolerance for contaminants on filler or base metals;
- c) difficult to shield the weld zone properly in drafty environments.

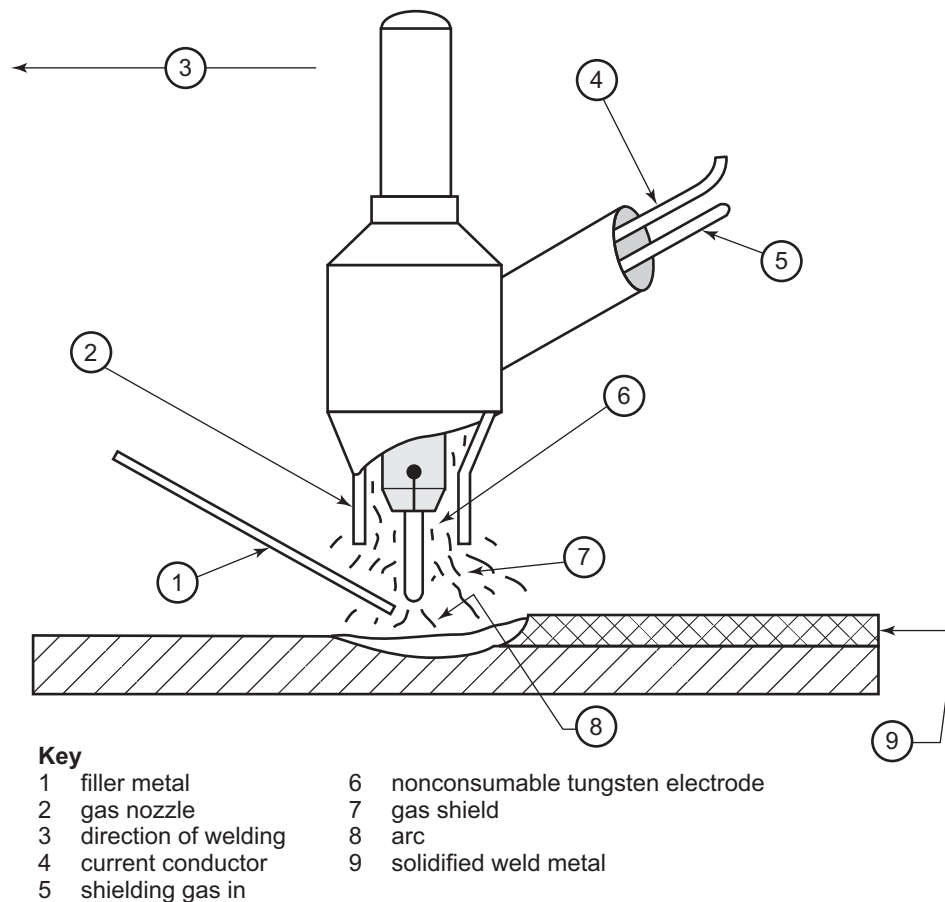

*From Jefferson's Welding Encyclopedia, 18th Edition, Reprinted Courtesy of AWS.*

**Figure 4—GTAW Welding**

## 5.4 Gas Metal Arc Welding (GMAW)

### 5.4.1 General

GMAW is an arc welding process that uses an arc between continuous filler metal electrode and the weld pool. The process is used with shielding from an externally supplied gas and without the application of pressure. GMAW may be operated in semiautomatic, machine, or automatic modes. It employs a constant voltage (CV) power supply, and uses either the short circuiting, globular, spray, or pulsed transfer modes to transfer metal from the electrode to the work. The type of transfer is determined by a number of factors. The most influential are:

- magnitude and type of welding current;
- electrode diameter;
- electrode composition;
- electrode extension or contact tube-to-work distance (often referred to as "stick out");
- shielding gas.

See Figure 5 and Figure 6 for schematics of the GMAW equipment and welding process.

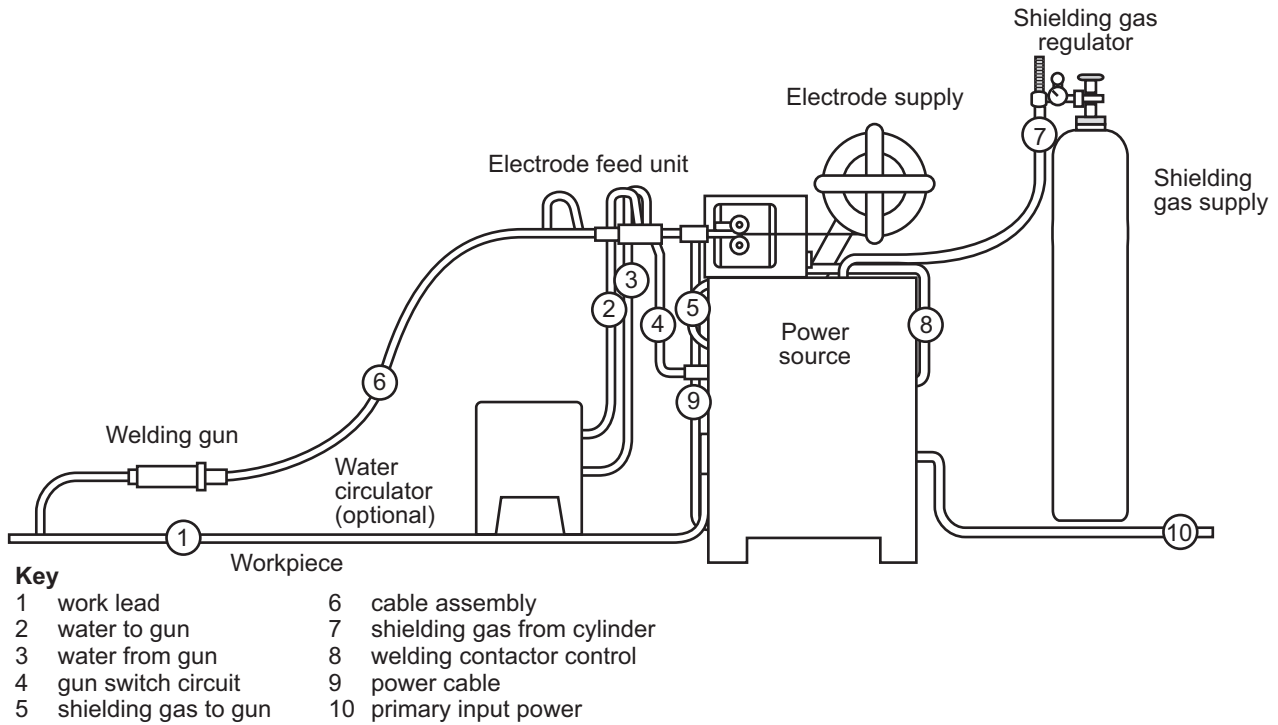

From Jefferson's Welding Encyclopedia, 18th Edition, Reprinted Courtesy of AWS.

**Figure 5—GMAW Equipment**

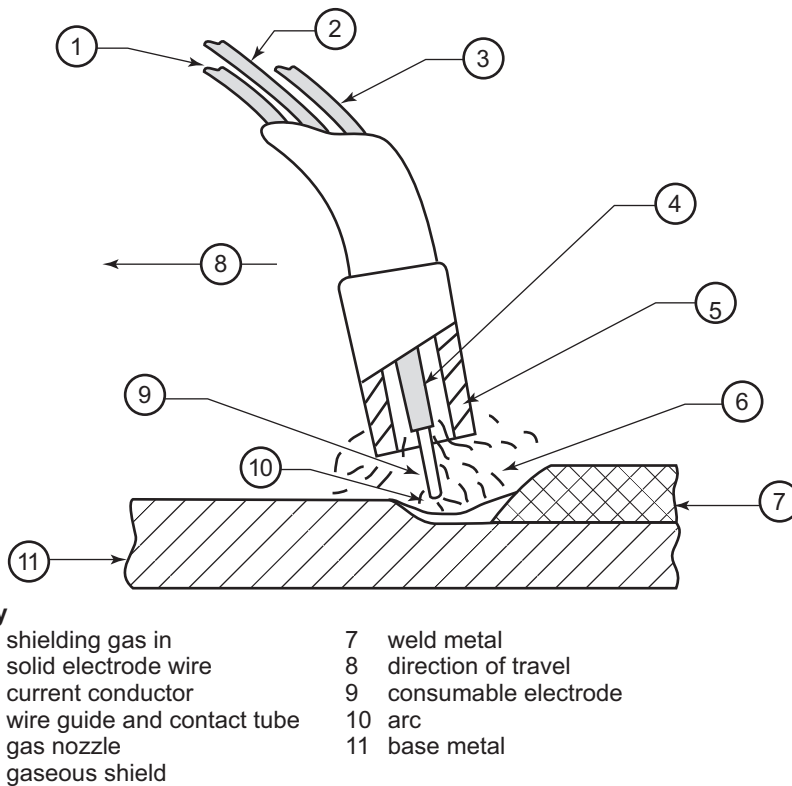

From Jefferson's Welding Encyclopedia, 18th Edition, Reprinted Courtesy of AWS.

**Figure 6—GMAW Welding**



## 5.4.2 Short Circuiting Transfer (GMAW-S)

### 5.4.2.1 General

GMAW-S encompasses the lowest range of welding currents and electrode diameters associated with the GMAW process. This process produces a fast freezing weld pool that is generally suited for joining thin sections, out-of-position welding, or root passes. Due to the fast-freezing nature of this process, there is potential for lack of sidewall and interpass fusion when welding thick-wall equipment or a nozzle attachment.

### 5.4.2.2 GMAW-MS (Modified Short Circuit)

The modified short-circuit GMAW process, designated the GMAW-MS process, has several proprietary derivatives of the short-circuiting transfer mode which use a modified waveform to reduce some of the problems found with short-circuiting—mainly, spatter and a turbulent weld pool. Typically these systems sense the progression of the short circuit as it happens and modulates the current to limit the amount of force behind spatter and turbulence-producing events. GMAW-MS power sources are software-driven to maintain optimum arc characteristics by closely monitoring and controlling the electrode current during all phases of the short-circuit. There are a limited number of companies that manufacture welding power supplies which employ this technology.

The GMAW-MS process minimizes the disadvantages of GMAW-S while maintaining comparable weld metal deposition rates and achieving X-ray quality welds. The welding process has the capability to complete open root welds more rapidly than GTAW, with low heat input and no lack of fusion. The lower heat input results in smaller heat affected zones (HAZ) as well as reduced distortion and chance of burn-through. The process appears to be more tolerant of less experienced welders since GMAW-MS is tolerant of gaps and capable of automatically maintaining the optimum wire feed speed and contact tip-to-work distance, and allows the use of larger diameter GMAW wires.

### 5.4.3 Globular Transfer

The advantages of this transfer method are its low cost when carbon dioxide is used as a shielding gas, and a high deposition rate. The maximum deposition rate for the globular arc transfer mode is about 250 in./min (110 mm/sec).

The globular arc transfer mode is often considered the least desirable of the GMAW variations due to the tendency to produce high heat, a poor weld surface, and weld spatter or a cold lap. This process uses relatively low current (below 250 A). During welding, a ball of molten metal from the electrode tends to build up on the end of the electrode, often in irregular shapes, with a diameter up to twice that of the electrode. When the droplet finally detaches (i.e. by gravity or short circuiting) and falls to the work piece, it produces an uneven surface and weld spatter. The welding process produces a high amount of heat and forces the welder to use a larger electrode wire. This increases the size of the weld pool, and causes greater residual stresses and distortion in the weld area. The welding process uses carbon dioxide as the shielding gas, and is limited to the flat and horizontal position.

### 5.4.4 Spray Transfer

The spray arc transfer mode results in a highly directed stream of discrete drops that are accelerated by arc forces. Since these drops are smaller than the arc length, short circuits do not occur and the amount of spatter generated is negligible. The inert gas shield allows the spray arc transfer mode to weld most metals. However, using this process on materials thinner than about 0.250 in. (6.4 mm) may be difficult because of the high currents needed to produce the spray arc. The spray arc transfer mode produces high weld metal deposition rates. At high deposition rates, the welding process may produce a weld metal pool that is too large to be supported by surface tension depending on the electrode diameter, limiting the use of the welding process in the vertical or overhead position. Specially designed power supplies have been developed to address the work thickness and welding position limitations. The maximum deposition rate for spray arc transfer mode is about 150 in./min (60 mm/sec).

### 5.4.5 Pulsed Transfer

The pulsed arc GMAW method was developed to overcome the thickness and welding position limitations. Pulsed GMAW welding is a variation of the GMAW process. The welding process uses:

- 1) a low background/constant current to sustain the arc without providing enough energy to produce drops at the tip of the wire; and
- 2) a superimposed/pulsing current with an amplitude greater than the transition current necessary for spray transfer.

During the pulsing portion of the current cycle, one or more drops are formed and transferred. The frequency and amplitude of the pulses control the rate at which the wire melts. Pulsing makes the desirable features of spray arc transfer available for joining sheet metals and welding in all positions. The maximum deposition rate for pulsed arc transfer mode is about 200 in./min (85 mm/sec). The pulsed arc GMAW method requires a power source capable of providing current pulses with a frequency between 30 pulses/sec and 400 pulses/sec, and requires that the shielding gas be primarily argon with a low carbon dioxide concentration.

### 5.4.6 Advantages of GMAW

Some commonly accepted advantages of the GMAW process include:

- a) the only consumable electrode process that can be used to weld most commercial metals and alloys;
- b) deposition rates are significantly higher than those obtained with SMAW;
- c) minimal postweld cleaning is required due to the absence of a slag.

### 5.4.7 Limitations of GMAW

Limitations associated with GMAW are:

- a) the welding equipment is more complex, more costly, and less portable than that for SMAW;
- b) the welding arc should be protected from air drafts that can disperse the shielding gas;
- c) when using the GMAW-S process, the weld is more susceptible to lack of adequate fusion.

## 5.5 Flux Cored Arc Welding (FCAW)

### 5.5.1 General

FCAW is an arc welding process that uses an arc between a continuous tubular electrode and the weld pool. The process is used with shielding gas evolved from a flux contained within the tubular electrode, with or without additional shielding from an externally supplied gas, and without the application of pressure. Normally a semiautomatic process, the use of FCAW depends on the type of electrodes available, the mechanical property requirements of the welded joints, and the joint designs and fit-up. The recommended power source is the dc constant-voltage type, similar to sources used for GMAW. Figure 7 shows a schematic of FCAW equipment, while Figure 8 shows the welding process with additional gas shielding. Figure 9 shows a schematic of the self-shielded FCAW process where no additional gas is used.

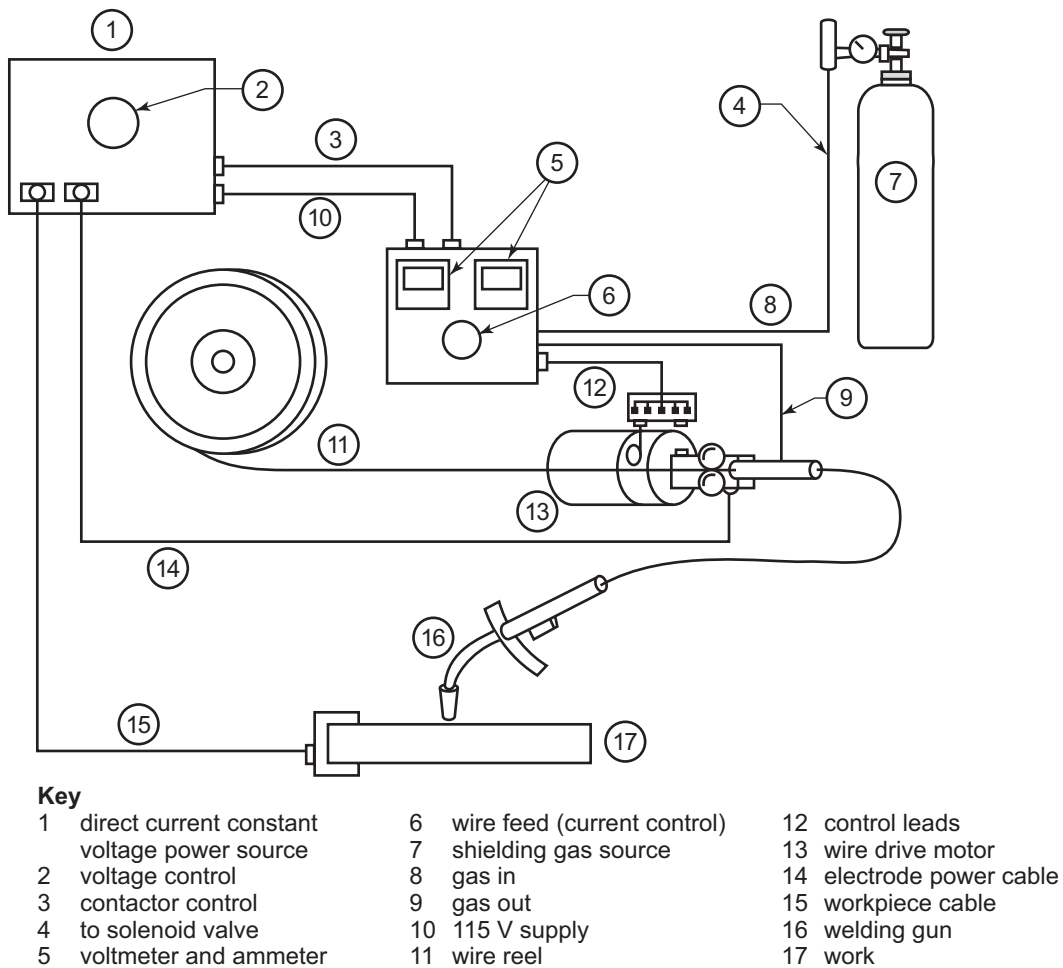

Note Gas shielding is used only with flux cored electrodes that require it.

*From Jefferson's Welding Encyclopedia, 18th Edition, Reprinted Courtesy of AWS.*

**Figure 7—FCAW Equipment**

### 5.5.2 Advantages of FCAW

Some commonly accepted advantages of the FCAW process include:

- The metallurgical benefits that can be derived from a flux.
- Slag that supports and shapes the weld bead.
- Higher deposition and productivity rates compared to other processes such as SMAW.
- Shielding is produced at the surface of the weld that makes it more tolerant of stronger air currents than GMAW.

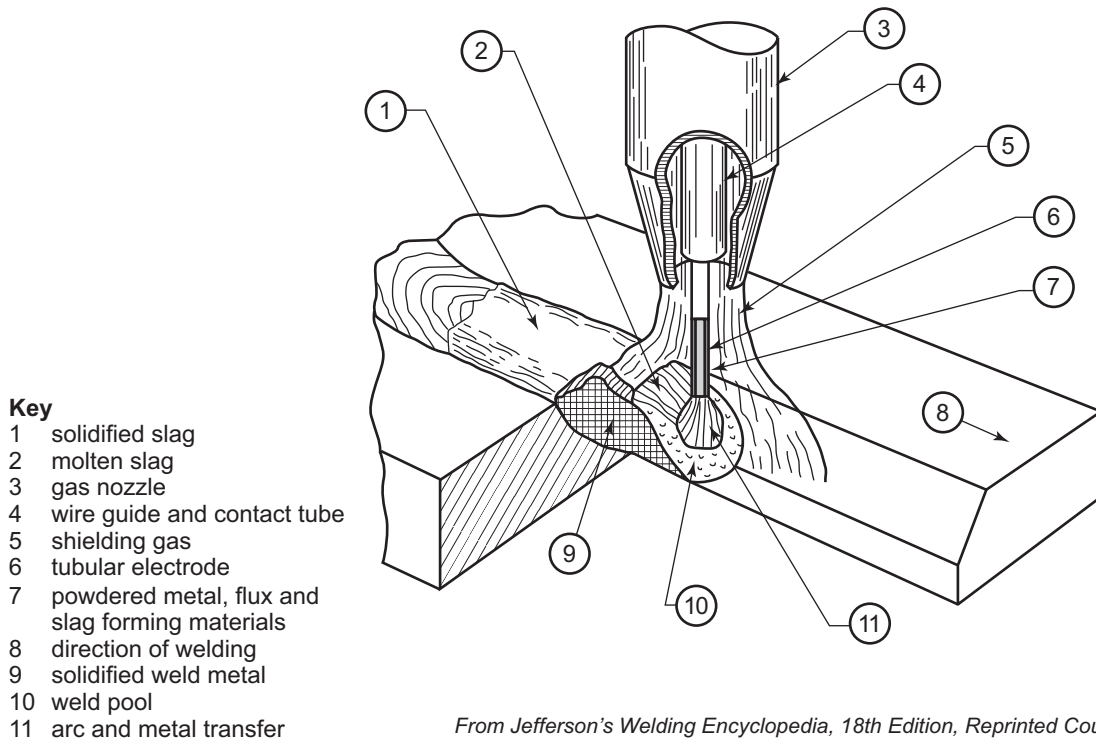

From Jefferson's Welding Encyclopedia, 18th Edition, Reprinted Courtesy of AWS.

**Figure 8—FCAW Welding**

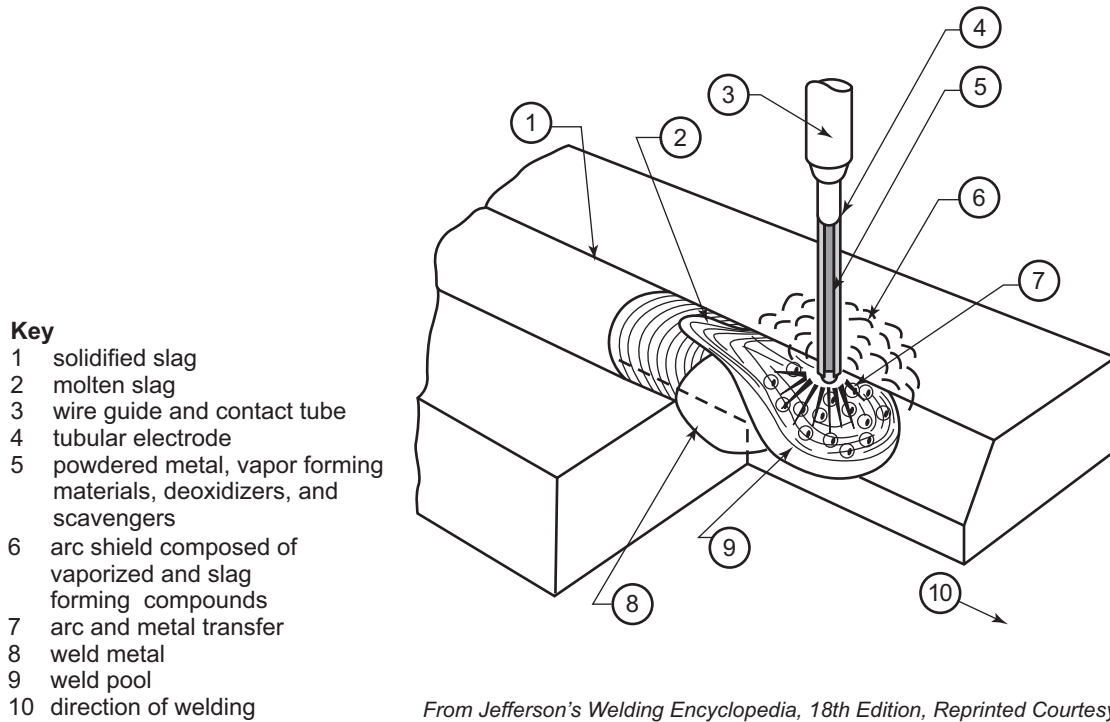

From Jefferson's Welding Encyclopedia, 18th Edition, Reprinted Courtesy of AWS.

**Figure 9—FCAW Welding, Self-shielded**

### 5.5.3 Limitations of FCAW

Self-shielded FCAW is typically not recommended for pressure-containing welds. Limitations associated with FCAW process are:

- a) Equipment is more complex, more costly, and less portable than that for SMAW.
- b) Self-shielding FCAW generates large volumes of welding fumes, and requires suitable exhaust equipment.
- c) Slag should be removed between weld passes, and removed from surfaces planned for inspection. If a weld is being placed in corrosive service, failure to remove slag from the weld cap or root can create sites for corrosion to initiate.
- d) Backing material is required for root pass welding.

## 5.6 Submerged Arc Welding (SAW)

### 5.6.1 General

Submerged arc welding is an arc welding process that uses an arc or arcs between a flux-covered bare metal electrode(s) and the weld pool. The arc and molten metal are shielded by a blanket of granular flux, supplied through the welding nozzle from a hopper. The process is used without pressure and filler metal from the electrode and sometimes from a supplemental source (welding rod, flux, or metal granules). SAW can be applied in three different modes: semiautomatic, automatic, and machine. It can utilize either a CV or CC power supply. SAW is used extensively in shop pressure vessel fabrication and pipe manufacturing. Figure 10 shows a schematic of the SAW process.

### 5.6.2 Advantages of SAW

Some commonly accepted advantages of the SAW process include:

- a) provides very high metal deposition rates;
- b) produces repeatable high quality welds for large weldments and repetitive short welds.

### 5.6.3 Limitations of SAW

Limitations associated with SAW are:

- a) a power supply capable of providing high amperage at 100 % duty cycle is recommended;
- b) weld is not visible during the welding process;
- c) equipment required is more costly and extensive, and less portable;
- d) process is limited to shop applications and flat position.

## 5.7 Stud Arc Welding (SW)

### 5.7.1 General

SW is an arc welding process that uses an arc between a metal stud or similar part and the work piece. Once the surfaces of the parts are properly heated (i.e. when the end of the stud is molten and the work has an equal area of molten pool), they are brought into contact by pressure. Shielding gas or flux may or may not be used. The process

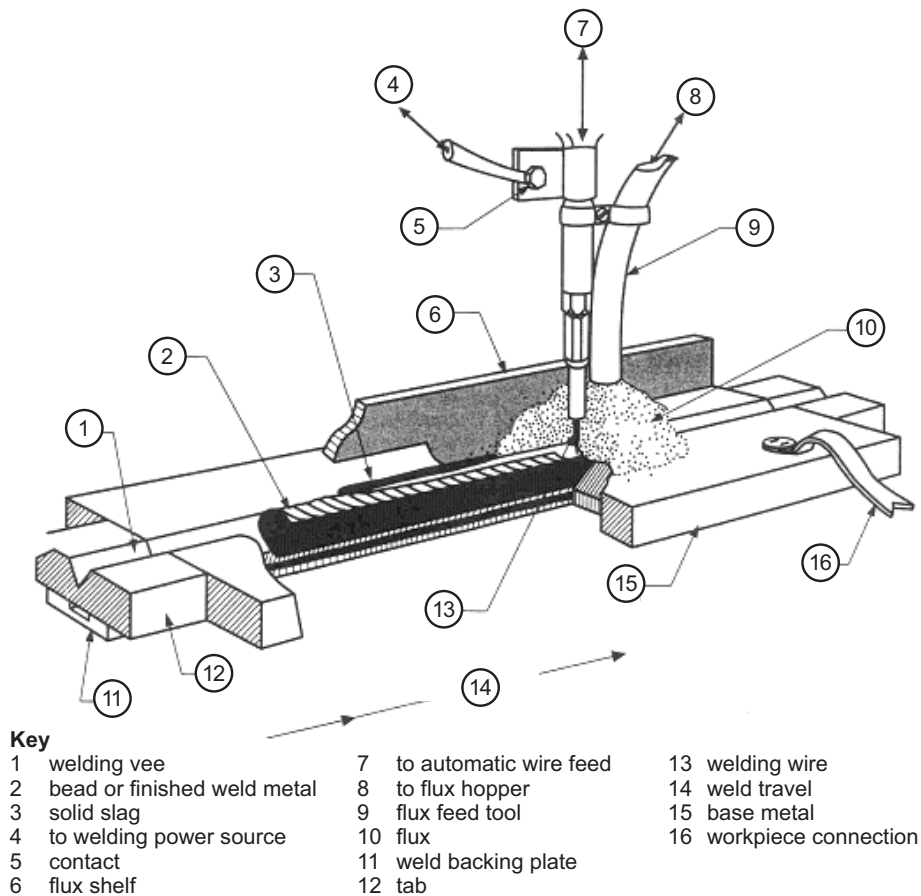

From Jefferson's Welding Encyclopedia, 18th Edition, Reprinted Courtesy of AWS.

**Figure 10—SAW Welding**

may be fully automatic or semiautomatic. A stud gun holds the tip of the stud against the work. Direct current is typically used for SW with the stud gun connected to the negative terminal (DCEN). The power source is a CC type.

SW is a specialized process predominantly limited to welding insulation and refractory support pins to tanks, pressure vessels and heater casings.

### 5.7.2 Advantages of SW

Some commonly accepted advantages of the SW process include:

- a) high productivity rates compared to manually welding studs to base metal;
- b) considered an all-position process.

### 5.7.3 Limitations of SW

Limitations of SW are:

- a) process is primarily suitable for only carbon steel and low-alloy steels;
- b) process is specialized to a few applications.

## 5.8 Plasma Arc Welding (PAW)

### 5.8.1 General

Plasma arc welding (PAW) is a variation of the gas tungsten arc welding (GTAW) process except that the tungsten electrode is positioned within the body of the torch. There are two types of plasma arc welding, namely the transferred arc process and non-transferred arc process. In the plasma transferred arc (PTA) process, similar to GTAW, the workpiece is part of the electrical circuit, and the arc is struck between the tungsten electrode and the workpiece. By constricting the arc, the plasma or ionized gas is forced through a fine-bore copper nozzle which constricts the arc, and exits the orifice at high velocities (approaching the speed of sound). The process produces a collimated arc which focuses the arc on a relatively small area of the workpiece with an arc temperature in excess of 20,000 °F (11,093 °C). In the non-transferred arc process, also referred as the plasma spray (PS) process, the arc is struck between the tungsten electrode and the constricting nozzle rather than with the work-piece. The plasma spray process is solely used for the deposition of surface coatings. It is not used for making strength welds. A comparison of the GTAW and PAW circuits and welding processes is shown in Figure 11.

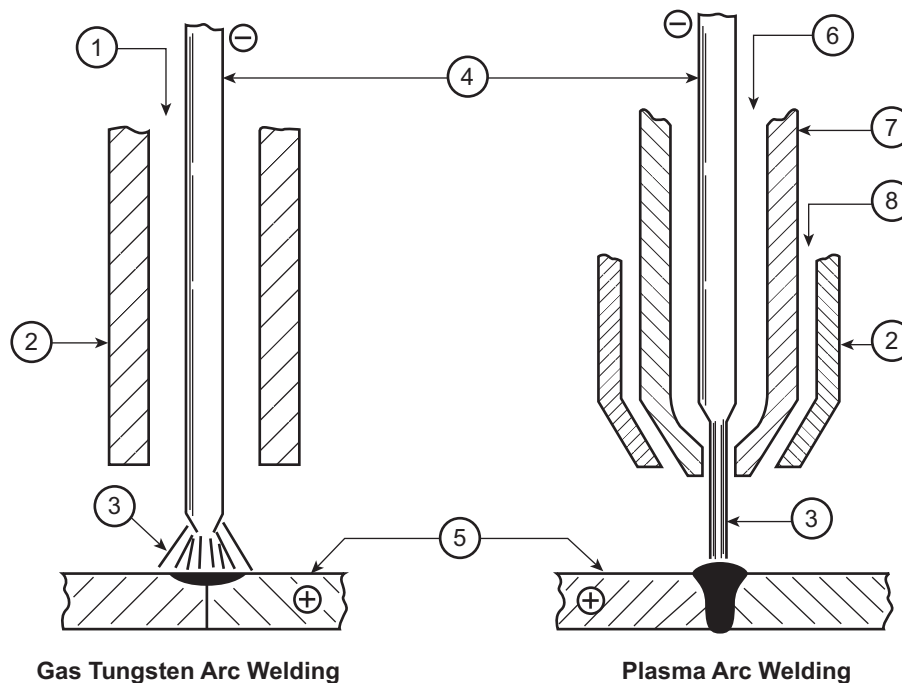

#### Key

- 1 shielding gas
- 2 shielding gas nozzle
- 3 arc plasma
- 4 electrode
- 5 workpiece
- 6 orifice gas shielding
- 7 constricting nozzle
- 8 shielding gas

Figure 11—Comparison of the Gas Tungsten Arc and Plasma Arc Welding Processes

### 5.8.2 Advantages of PAW

Some commonly accepted advantages of the PAW process include:

- a) arc has good tolerance to misalignments;

- b) high welding rate;
- c) high penetrating capability (keyhole effect);
- d) lower total heat input due to focused arc results in less distortion;
- e) welds produced are narrower than GTAW due to the constricted arc.

### 5.8.3 Limitations of PAW

The limitations of plasma arc welding include:

- a) expensive equipment;
- b) larger torch than GTAW makes access more difficult in narrow weld joints;
- c) Focused arc requires better control by the welder

## 5.9 Electrogas Welding (EGW)

### 5.9.1 General

Electrogas welding (EGW) is similar to the GMAW process in that it a solid electrode can be fed into the joint. Alternately, similar to the FCAW process in that a flux cored tubular electrode can be used. The weld is deposited in the flat position with the molten metal continually being deposited at the bottom of the moving cavity. In electrogas welding, fixed or moving metal (usually copper) or ceramic shoes (or dams), water cooled if needed, are set up before starting, to bridge the gap between abutting plates and contain the molten metal until solidification is completed. The welding process utilizes either a solid wire or flux-cored electrode. The weld area is protected from atmospheric contamination by an externally supplied shielding gas, or by the gas produced by the disintegration of the flux-cored electrode wire. Electrogas welding is used to make square-groove welds for butt and T-joints in the construction of storage tanks, ship hulls and pressure vessels with plate thicknesses from  $\frac{3}{8}$  in. to 4 in. (10 mm to 100 mm). The workpiece should be at least 0.4 in. (10 mm) thick, while the maximum thickness for one electrode is approximately 0.8 in. (20 mm). Additional electrodes make it possible to weld thicker workpieces. The height of the weld is limited only by the mechanism used to lift the welding head. In general, it ranges from 4 in. (100 mm) to 50 ft (20 m).

Low and medium carbon steels, low alloy high strength steels, and some stainless steels can be welded using the electrogas process. Quenched and tempered steels may also be welded by the process, provided that the proper amount of heat is applied. Figure 12 shows an electrogas welding set-up using a solid electrode.

### 5.9.2 Advantages of EGW

Some commonly accepted advantages of the EGW process include:

- a) welding is usually done in one pass;
- b) very high deposition rates;
- c) minimum distortion.



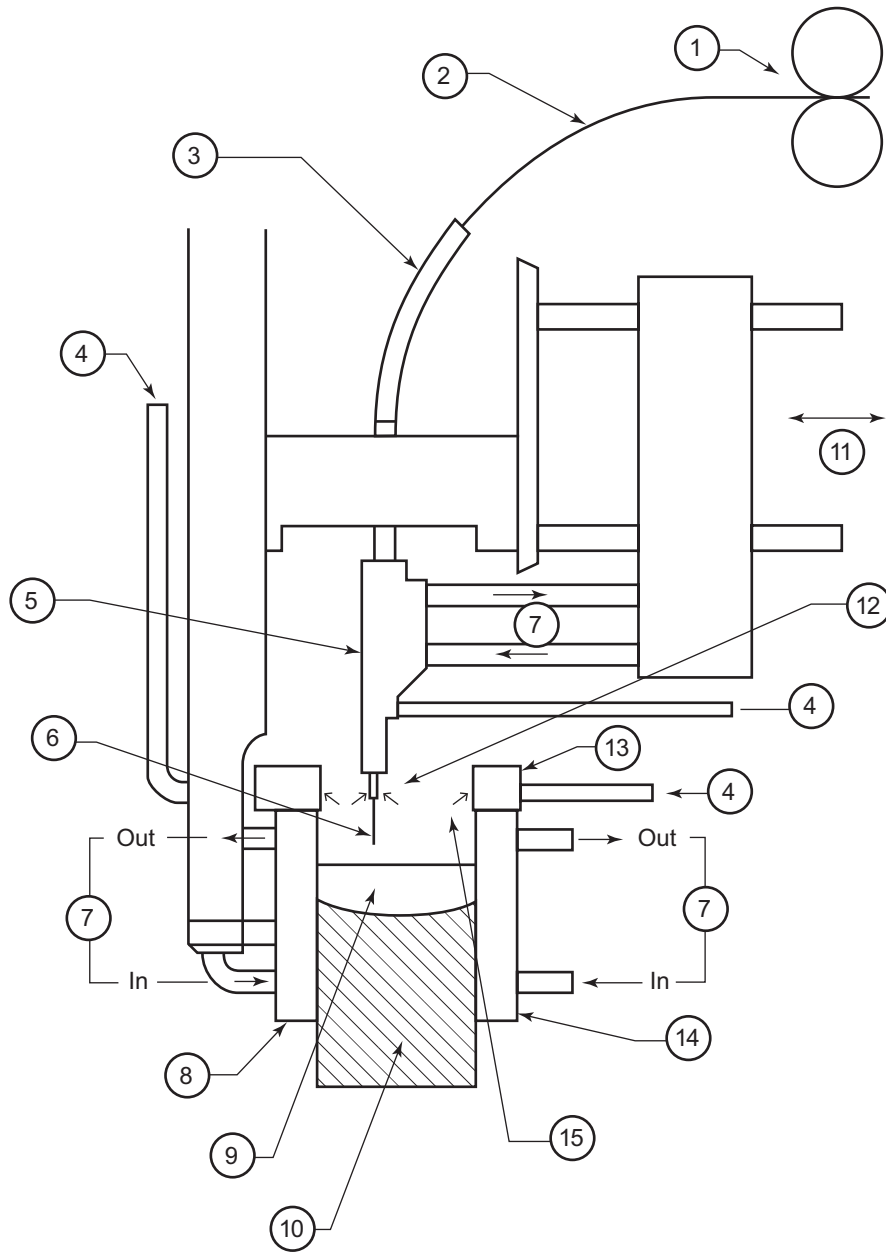

**Key**

- |                     |                                |
|---------------------|--------------------------------|
| 1 drive rolls       | 9 weld pool                    |
| 2 welding wire      | 10 solidified weld metal       |
| 3 electrode conduit | 11 oscillator                  |
| 4 gas               | 12 primary shielding gas       |
| 5 electrode guide   | 13 gas box                     |
| 6 welding wire      | 14 adjustable shoe             |
| 7 water             | 15 supplementary shielding gas |
| 8 fixed shoe        |                                |

**Figure 12—Electrogas Welding with a Solid Electrode**

### 5.9.3 Limitations of EGW

Some limitations of EGW include:

- a) poor toughness;
- b) massive, expensive welding equipment and guidance systems are required;
- c) lengthy set-up times are needed;
- d) can only be used with vertically positioned joints;
- e) can require external source of shielding gas.

## 6 Welding Procedure

### 6.1 General

Qualified welding procedures are required for welding fabrication and repair of pressure vessels, piping and tanks. They detail the steps necessary to make a specific weld and generally consist of a written description, details of the weld joint and welding process variables, and test data to demonstrate the procedure produces weldments that meet design requirements.

While various codes and standards exist for the development of welding procedures, this section reflects criteria described in ASME Section IX. Welding procedures qualified to ASME Section IX are required by API inspection codes for repair welding and are often required by construction codes used in fabrication of new equipment and piping. However, construction codes and proprietary company specifications may have additional requirements or allow specific exceptions so they should be reviewed for each weld application.

Welding procedures required by ASME Section IX include a written welding procedure specification (WPS) and procedure qualification record (PQR). The WPS provides direction to the welder while making production welds to ASME code requirements. The PQR is a record of the welding data and variables used to weld a test coupon and the test results used to qualify the welding procedure.

It is important to differentiate the PQR and welder performance qualification (WPQ), detailed in Section 7. The purpose of the PQR is to establish the properties of the weldment. The purpose of the WPQ is to establish the welder is capable of making a quality weld using the welding procedure.

### 6.2 Welding Procedure Specification (WPS)

#### 6.2.1 General

ASME Section IX requires each manufacturer and contractor to develop welding procedures. Whereas this requirement appears repetitious, qualified welding procedure specifications are an important aspect of fabrication quality control. They help each organization recognize the significance of changes in welding variables that may be required on the job, and the effects of the changes on weldment properties. The WPS is but one step for welding fabrication quality assurance. ASME B31.3 allows welding procedure qualification by others, provided it is acceptable to the inspector and meets certain conditions.

The completed WPS for a welding process addresses all essential, nonessential, and supplementary essential variables when impact testing is required, or when specified by the end user. Essential variables affect the mechanical properties of the weld. If they are changed beyond what the reference code paragraph allows for the process, the WPS must be re-qualified. Nonessential variables do not affect the mechanical properties of the weld.

They may be changed on the WPS without re-qualifying the welding procedure. Supplementary essential variables apply, or when specified by the end user, are treated as essential variables when they apply.

### 6.2.2 Types of Essential Variables

The WPS should contain, as a code requirement, the following information:

- a) process(es);
- b) base metal;
- c) filler metal (and/or flux);
- d) welding current;
- e) welding position;
- f) shielding gas, if used;
- g) preparation of base metal;
- h) fit-up and alignment;
- i) backside of joint;
- j) peening;
- k) preheat;
- l) postweld heat treatment;
- m) welding technique (weaving, multiple or single pass, etc.);
- n) cleaning method;
- o) back gouge method.

### 6.2.3 Other Requirements

The WPS should also reference the supporting PQR(s) used to qualify the welding procedure. In addition, the construction code or proprietary company specifications can impose specific requirements related to service of the equipment and piping. These can include:

- a) toughness of base metal, weld metal, and HAZ;
- b) limitations of welding process;
- c) limitations of filler metals and fluxes;
- d) critical joint geometries;
- e) limitations on preheat;
- f) limitations on PWHT;

- g) limitations on weld metal hardness;
- h) limitations on the chemical composition of base metal and filler metal;
- i) base metal heat treatment condition limitation;
- j) limitations on thickness.

These requirements should be reflected in the WPS.

The format of the WPS is not fixed, provided it addresses all essential and nonessential variables (and supplementary essential variables when necessary). An example form is available in ASME Section IX, Annex B.

The WPS should be available for review by the Inspector. Since it provides the limits the welder is responsible for staying within, it should be available to the welder as well.

### **6.3 Procedure Qualification Record (PQR)**

The PQR records the essential and nonessential variables used to weld a test coupon, the coupon test results, and the manufacturer's certification of accuracy in the qualification of a WPS. Record of the nonessential variables used during the welding of the test coupon is optional.

ASME Section IX requires that the manufacturer or contractor supervise the production of the test weldments and certify that the PQR properly qualifies the welding procedure; however, other groups may perform sample preparation and testing. Mechanical tests are required to qualify a welding procedure to demonstrate the properties of the weldment. Test sample selection and testing requirements are defined in Section IX. Typically, they include tension test to determine the ultimate strength of a groove weld, guided bend tests to determine the degree of soundness and ductility of a groove weld, notch toughness testing when toughness requirements are imposed, and hardness measurements when hardness restrictions are defined. If any test specimen fails, the test coupon fails and a new coupon is required.

The format of the PQR is not fixed, provided it addresses all essential variables (and supplementary essential variables when necessary). An example form is available in ASME Section IX, Annex B.

The PQR should accompany the WPS and be available for review by the Inspector upon request. It does not need to be available to the welder. One PQR may support several WPSs. One WPS may be qualified by more than one PQR within the limitations of the code.

### **6.4 Reviewing a WPS and PQR**

#### **6.4.1 General**

Inspectors should review the WPS and PQR to verify they are acceptable for the welding to be done. While there are many ways to review a welding procedure, the most effective one utilizes a systematic approach that assures a complete and thorough review of the WPS and PQR to verify that all ASME Section IX and construction and repair code requirements have been satisfied.

The initial step is to verify the WPS has been properly completed and addresses the requirements of Section IX and the construction/repair code. The second step is to verify the PQR has been properly completed and addresses all the requirements of Section IX and the construction and repair code. The third step is to confirm the PQR essential variable values properly support the range specified in the WPS.

For simplicity purposes, the following list is for a single weld process on the WPS when notch toughness is not a requirement (so supplementary essential variables do not apply).

#### 6.4.2 Items to be Included in the WPS

Items typically included in the WPS are as follows.

- a) Name of the company using the procedure.
- b) Name of the individual that prepared the procedure.
- c) Unique number or designation that will distinguish it from any others, and date.
- d) Supporting PQR(s).
- e) Current revision and date, if revised.
- f) Applicable welding process (i.e. SMAW, GTAW, GMAW, FCAW, SAW).
- g) Type of welding process (i.e. automatic, manual, machine, or semi-automatic).
- h) Backing material, if any, used for each process. The joint design information applicable to the process (i.e. type of joint, groove angle, root spacing, root face dimensions, backing material and function).
- i) Base metal's P-number and, if applicable, group number of the metals being joined, or specification type and grade, or chemical analysis and mechanical properties.
- j) Thickness range the procedure is to cover.
- k) Diameter (for piping) the procedure is to cover.
- l) Filler metal specification (SFA number).
- m) AWS classification number.
- n) F-number (see QW-432).
- o) A-number (see QW-442).
- p) Filler metal size.
- q) Deposited metal thickness and passes greater than  $\frac{1}{2}$  in. (12.7 mm) thickness.
- r) Electrode-flux class and trade name, if used.
- s) Consumable insert, if used.
- t) Position and progression qualified for use in production welding.
- u) Minimum preheat temperature (including preheat maintenance requirements) and maximum interpass temperature the weldment is to receive throughout welding.
- v) Postweld heat treatment temperature and hold time (if applied).
- w) Type, composition, and flow rates for shielding, trailing, and backing gases (if used).

- x) Current, polarity, amperage range, and voltage range for production welding (for each electrode size, position, and thickness, etc.).
- y) Tungsten electrode size and type (if GTAW).
- z) Metal transfer mode (if GMAW or FCAW).
- aa) Technique including string or weave bead, initial and interpass cleaning, peening, and other weld process specific nonessential variables.

#### **6.4.3 Items to be Included in the PQR**

Items typically included in the PQR are as follows.

- a) Name of the company that qualified the procedure.
- b) Unique number or designation and the date.
- c) WPS number that the PQR supports.
- d) Type of weld for qualification (groove, fillet, other).
- e) Test coupon thickness.
- f) Test coupon diameter.
- g) P-numbers of coupon welded.
- h) Filler metal F-number.
- i) Filler metal A-number.
- j) Position and progression.
- k) Total weld metal thickness deposited.
- l) Any single weld pass thickness greater than  $\frac{1}{2}$  in. (12.7 mm).
- m) Preheat temperature.
- n) PWHT temperature and thickness limit.
- o) Gas.
- p) Electrical Characteristics.
- q) Technique.
- r) Proper number, size, and test results for tensile tests.
- s) Proper number, type, and results for bend tests.
- t) Additional test results if required by construction code or project specification.

- u) Certification signature and date.
- v) Welder's Name.
- w) Tests Conducted by & Record number.
- x) Maximum interpass temperature recorded.

The review should confirm that the PQR variables adequately represent and support the range specified in the WPS for the production application. While this example serves to illustrate a suggested approach to reviewing welding procedures, it has not addressed specific variables and nuances required to have a properly qualified welding procedure. Additionally, Annex C provides an example of using a checklist for the review of WPS and PQRs.

## **6.5 Tube-to-Tubesheet Welding Procedures**

### **6.5.1 General**

Tube-to-tubesheet welds have many factors affecting weld quality that are different than that for conventional groove and fillet welds. These factors result mainly from the unique geometry of the welds. Therefore, a demonstration mockup in accordance with ASME IX QW-193 may be required by the construction code or proprietary company specifications.

### **6.5.2 Essential Variables**

The types of essential variables listed in ASME IX QW-288 include:

- a) joint configuration;
- b) tube and tubesheet thickness
- c) ligament thickness
- d) multi versus single pass
- e) welding position
- f) interpass temperature
- g) tube expansion
- h) cleaning method
- i) electrode or filler metal diameter
- j) inserts
- k) specific requirements for explosive welding
- l) weld process and type;
- m) vertical position progression;
- n) P# and A#;
- o) preheat;
- p) PWHT;
- q) weld current level;

- r) polarity or current type;
- s) welding type;
- t) F Number;
- u) shielding gas;
- v) gas flow rate.

### 6.5.3 Procedure Qualification Test

The procedure qualification test requirements for tube-to-tubesheet welds are specified in ASME IX QW-193. The tests include:

- a) visual;
- b) dye penetrant;
- c) macro examination of weld cross sections.

Other testing that may be specified by the construction code or proprietary company specifications include:

- a) hardness testing;
- b) shear load test in accordance with ASME VIII, Div. 1, Annex A.

## 7 Welding Materials

### 7.1 General

Welding materials refers to the many materials involved in welding including the base metal, filler metal, fluxes, and gases, if any. Each of these materials has an impact on the WPS and the weldment properties. An understanding of the conventions used by the ASME Section IX is necessary to adequately review qualified welding procedures.

### 7.2 P-Number Assignment to Base Metals

Base metals are assigned P-numbers in ASME Section IX to reduce the number of welding procedure qualifications required. For ferrous base metals having specified impact test requirements, group numbers within P-numbers are assigned. These assignments are based on comparable base metal characteristics such as composition, weldability, and mechanical properties. Table 1 lists the assignments of base metal to P-numbers.

A complete listing of P-number, S-number, and group number assignments are provided in QW/QB-422 of ASME Section IX. This list is an ascending sort based on specification numbers. Specification numbers grouped by P-number and group number are also listed in ASME Section IX nonmandatory Annex D. Within each list of the same P-number and group number, the specifications are listed in an ascending sort.

### 7.3 F-Number Assignment to Filler Metals

Electrodes and welding rods are assigned F-numbers to reduce the number of welding procedure and performance qualifications. The F-number groupings are based essentially on their usability characteristics, which fundamentally determine the ability of welders to make satisfactory welds with a given process and filler metal.

Welders who qualify with one filler metal are qualified to weld with all filler metals having the same F-number, and in the case of carbon steel SMAW electrodes, may additionally qualify to weld with electrodes having other F-numbers. For example, a welder who qualified with an E7018 is qualified to weld with all F-4 electrodes, plus all F-1, F-2, and F-3 electrodes (with backing limitations). The grouping does not imply that base metals or filler metals within a group may be indiscriminately substituted for a metal, which was used in the qualification test. Consideration should be



**Table 1—P-Number Assignments**

Base Metal	Welding	Brazing
Steel and alloys	P-No.1 through P-No. 11, including P-No. 5A, 5B, 5C, and 15E	P-No. 101 through P-No. 103
Aluminum and aluminum-base alloys	P-No. 21 through P-No. 25	P-No. 104 and P-No. 105
Copper and copper-base alloys	P-No. 31 through P-No. 35	P-No. 107 and P-No. 108
Nickel and nickel-base alloys	P-No. 41 through P-No. 47	P-No. 110 through P-No. 112
Titanium and titanium-base alloys	P-No. 51 through P-No. 53	P-No. 115
Zirconium and zirconium-base alloys	P-No. 61 through P-No. 62	P-No. 117

*Reprinted Courtesy of ASME.*

given to the compatibility of the base and filler metals from the standpoint of metallurgical properties, postweld heat treatment, design and service requirements, and mechanical properties.

A complete list of F-numbers for electrodes and welding rods is given in ASME Section IX, Table QW-432.

#### **7.4 AWS Classification of Filler Metals**

An AWS classification number identifies electrodes and welding rods. The AWS classification numbers are specified in ASME Section IIC under their appropriate SFA specification number. ASME Section IX Table QW-432 lists the AWS classification numbers and SFA specification numbers included under each of the F-numbers. Note that the X's in the AWS classification numbers represent numerals, i.e. the AWS classifications E6010, E7010, E8010, E9010, and E10010 are all covered by F-number 3 (EXX10). Annex A contains additional details on the conventions used in identification of filler metals for the welding processes.

#### **7.5 A-Number**

To minimize the number of welding procedure qualifications, steel and steel alloy filler metals are also grouped according to their A-number. The A-number grouping in ASME Section IX, Table QW-442 is based on the chemical composition of the deposited weld metal. This grouping does not imply that filler metals may be indiscriminately substituted without consideration for the compatibility with the base metal and the service requirements.

#### **7.6 Filler Metal Selection**

Inspectors should verify the filler metal selection is appropriate for the base metal being welded. Some considerations in selection include:

- a) chemical composition of filler metal;
- b) tensile strength of filler metal and base metal;
- c) dilution of alloying elements from base metal;
- d) hardenability of filler metal;
- e) susceptibility to hot cracking;

f) corrosion resistance of filler metal.

Annex D provides a guide of common filler metals for base metals most often used in petrochemical plants. In addition, there is a table comparing the current AWS filler metal classification to the previous ones for low-alloy steels. AWS modified the classifications for several common low-alloy filler metals.

## 7.7 Consumable Storage and Handling

Welding consumable storage and handled guidelines should be in accordance with the consumable manufacturer's instructions and guidelines and as given in the AWS A5.XX series of filler metal specifications. Covered electrodes exposed to moisture can become unstable due to moisture pickup by the coating. Particularly susceptible to moisture pickup are coatings on low-hydrogen electrodes and stainless steel electrodes. Moisture can be a source of hydrogen.

To reduce exposure to moisture, certain welding consumables should be stored in warm holding ovens after they have been removed from the manufacturer's packaging. Low-hydrogen SMAW electrodes supplied in non-hermetically sealed containers should be baked according to manufacturer's instructions prior to use. They should be stored separately from other types of electrodes with higher hydrogen content, as this can be another source for hydrogen pickup. Some welding consumables that are slightly damp can be reconditioned by baking in separate special ovens. Ovens should be heated by electrical means and have automatic heat controls and visible temperature indications. Ovens should only be used for electrode storage as using them for food storage or cooking could cause electrode coatings to absorb moisture. Any electrodes or fluxes that have become wet should be discarded.

## 8 Welder Qualification

### 8.1 General

Welder performance qualification is to establish the welder's ability to deposit sound weld metal. Similar to welding procedure qualification, this section reflects the parameters in the referencing code or typically referenced to ASME Section IX. Other codes exist which utilize other means for welder qualification. The term welder is intended to apply to both welders and welding operators for the purpose of the following descriptions.

The welder qualification is limited by the essential variables given for each process. A welder may be qualified by radiography of a test coupon or of an initial production weld or by bend tests of a test coupon. Some end users and codes limit or restrict the use of radiography. The responsibility for qualifying welders is typically restricted to the contractor or manufacturer employing the welder and cannot be delegated to another organization. However, some codes such as B31.3 may modify this rule and generally it is permissible to subcontract test specimen preparation and NDE.

### 8.2 Welder Performance Qualification (WPQ)

The WPQ addresses all essential variables listed in QW-350 of ASME Section IX. The performance qualification test coupon is to be welded according to the qualified WPS, and the welding is supervised and controlled by the employer of the welder. The qualification is for the welding process used, and each different welding process requires qualification. A change in any essential variable listed for the welding process requires the welder to re-qualify for that process.

QW-352 through QW-357 in ASME Section IX, list the essential variables and referencing code paragraphs for different welding processes. The variable groups addressed are: joints, base metals, filler metals, positions, gas, and electrical characteristics.

The record of the WPQ test includes all the essential variables, the type of test and test results, and the ranges qualified. The format of the WPQ is not fixed provided it addresses all the required items. An example form is available in ASME Section IX—Form QW-484 in nonmandatory Annex B.

Mechanical tests performed on welder and welding operator qualification test coupons are defined in ASME Section IX, QW-452 for type and number required. If radiographic examination is used for welder or welding operator qualification of coupons, the minimum length of coupon to be examined is 6 in. (152.4 mm), and includes the entire weld circumference for pipe coupons. Coupons are required to pass visual examination and physical testing, if used. Alternately, welders and welding operators making a groove weld using SMAW, SAW, GTAW, and GMAW (except short-circuit mode) may be qualified using radiography of the first production weld. For welders, a minimum of 6 in. (150 mm) length of the first production weld must be examined for performance qualification while a minimum of 3 ft (0.91 m) length must be examined for welding operators.

There are rules (e.g. ASME Section IX) for the immediate retesting of welders or welding operators who fail a qualification test and is commonly referred to as the “two for one rule” whereby the welder/operator must be tested on twice the original extent of tests. Welders or welding operators who fail the second test typically have to be sent for retraining but no clear guidance is provided to inspectors on what constitutes retraining. Documented evidence of retraining and production of acceptable practice welds should be presented to the inspector before allowing a further test.

Welder performance qualification expires if the welding process is not used during a six-month period. The welder’s qualification can be revoked if there is a reason to question their ability to make welds. A welder’s log or continuity report can be used to verify that a welder’s qualifications are current.

### **8.3 Reviewing a WPQ**

#### **8.3.1 Review Prior to Welding**

Prior to any welding, inspectors should review welders’ WPQ to verify they are qualified to perform the welding given its position and process. When reviewing a WPQ, items to check include:

- a) welders name and stamp number;
- b) welding process and type;
- c) identification of WPS used for welding test coupon;
- d) backing (if used);
- e) P-number(s) of base metals joined;
- f) thickness of base metals and diameter if pipe;
- g) filler metal SFA number;
- h) filler metal F-number;
- i) consumable insert (if used);
- j) deposited thickness (for each process used);
- k) welding position of the coupon;
- l) vertical weld progression;

- m) backing gas used;
- n) metal transfer mode (if GMAW);
- o) weld current type/polarity (if GTAW);
- p) if machine welded—refer to QW-484 for additional values required;
- q) guided bend test type and results, if used;
- r) visual examination results;
- s) additional requirements of the construction code;
- t) testing organization identification, signature, and date;
- u) radiographic results (if used).

### **8.3.2 Verifying the Qualification Range**

The following ASME Section IX references should be used to verify the qualification range:

- a) base metal qualification—QW-423.1 and QW-403.15;
- b) backing—QW-350 and QW-402.4;
- c) deposited weld metal thickness qualification—QW-452.1 (if transverse bend tests) and QW-404.30;
- d) groove weld small diameter limits—QW-452.3 and QW-403.16;
- e) position and diameter limits—QW-461.9, QW-405.3 and QW-403.16;
- f) F-number—QW-433 and QW-404.15.

### **8.3.3 Welder Qualifications for Tube to Tubesheet Welding**

When a demonstration mockup in accordance with ASME IX QW-193 is required by the construction code or proprietary company specifications the welder qualification requirements have the same essential variables and acceptable ranges as in the welding procedure qualification (WPQ) used to support the welding procedure specification (WPS).

### **8.3.4 Limitations for Welder Qualifications**

Limitations for welders or welding operators are discussed in ASME Section IX, Para. QW-305.

## **9 Non-destructive Examination**

### **9.1 Discontinuities**

Non-destructive Examination (NDE) is defined as those inspection methods, which allow materials to be examined without changing or destroying their usefulness. NDE is an integral part of the quality assurance program. A number of NDE methods are employed to ensure that the weld meets design specifications and does not contain defects.

The inspector should choose an NDE method that has the capability and adequate sensitivity to detect discontinuities in the weld joints requiring examination for accept/reject evaluation. Table 2 and Figure 13 list the common types and location of discontinuities and illustrate their positions within a butt weld. The most commonly used NDE methods used during weld inspection are shown in Table 3.

Table 4 lists the various weld joint types and common NDE methods available to inspect their configuration. Table 5 further lists the detection capabilities of the most common NDE methods. Additional methods, like alternating current field measurement (ACFM), have applications in weld inspection and are described in this section but are less commonly used.

The inspector should be aware of discontinuities common to specific base metals and weld processes to assure these discontinuities are detectable. Table 6 is a summary of these discontinuities, potential NDE methods and possible solutions to the weld process.

**Table 2—Common Types of Discontinuities**

Type of Discontinuity	Section	Location	Remarks	
1) Porosity	2.3	WM	Porosity could also be found in the BM and HAZ if the base metal is a casting.	
a) Uniformly scattered	2.3.1			
b) Cluster	2.3.2			
c) Piping	2.3.3			
d) Aligned	2.3.4			
e) Elongated	2.3.5			
2) Porosity	2.4	WM, WI		
a) Uniformly scattered	2.4.1			
b) Cluster	2.4.2			
3) Incomplete fusion	2.5	WM/MI	WM between passes.	
4) Incomplete joint penetration	2.6	BM	Weld root.	
5) Undercut	2.7	WI	Adjacent to weld toe or weld root in base metal.	
6) Underfill	2.8	WM	Weld face or root surface of a groove weld.	
7) Overlap	2.9	WI	Weld toe or root surface.	
8) Lamination	2.10	BM	Base metal, generally near midthickness of section.	
9) Delamination	2.11	BM	Base metal, generally near midthickness of section.	
10) Seam and lap	2.12		Base metal surface generally aligned with rolling direction.	
11) Lamellar tear	2.13	BM	Base metal, near HAZ.	
12) Crack includes hot cracks and cold cracks described in text)	2.14	WM, HAZ, BM	Weld metal or base metal adjacent to WI.	
Longitudinal	2.14.1			
	2.14.2			
Transverse	2.14.3		WM, HAZ, BM	Weld metal (may propagate into HAZ and base metal).
	2.14.2			
	2.14.4			
Crater	2.14.5		WM	Weld metal at point where arc is terminated.
Throat	2.14.6		WM	Parallel to weld axis. Through the throat of a fillet weld.
Toe	2.14.7		WM, HAZ	
Root	2.14.8	WI, HAZ	Root surface or weld root.	
Underbead and HAZ	2.14.9	HAZ		
13) Concavity	2.15	WM	Weld face or fillet weld.	
14) Convexity	2.16	WM	Weld face or fillet weld.	
15) Weld reinforcement	2.17	WM	Weld face of a groove weld.	

LEGEND

WM—weld metal zone  
 BM—base metal zone  
 HAZ—heat-affected zone  
 WI—weld interface

*From AWS B1.10 Reprinted Courtesy of AWS.*

**Table 3—Commonly Used NDE Methods**

Type of Test	Symbols
Visual	VT
Magnetic Particle	MT
Wet Fluorescent Magnetic Particle	WFMT
Liquid Penetrant	PT
Leak	LT
Eddy Current	ET
Radiographic	RT
Ultrasonic	UT

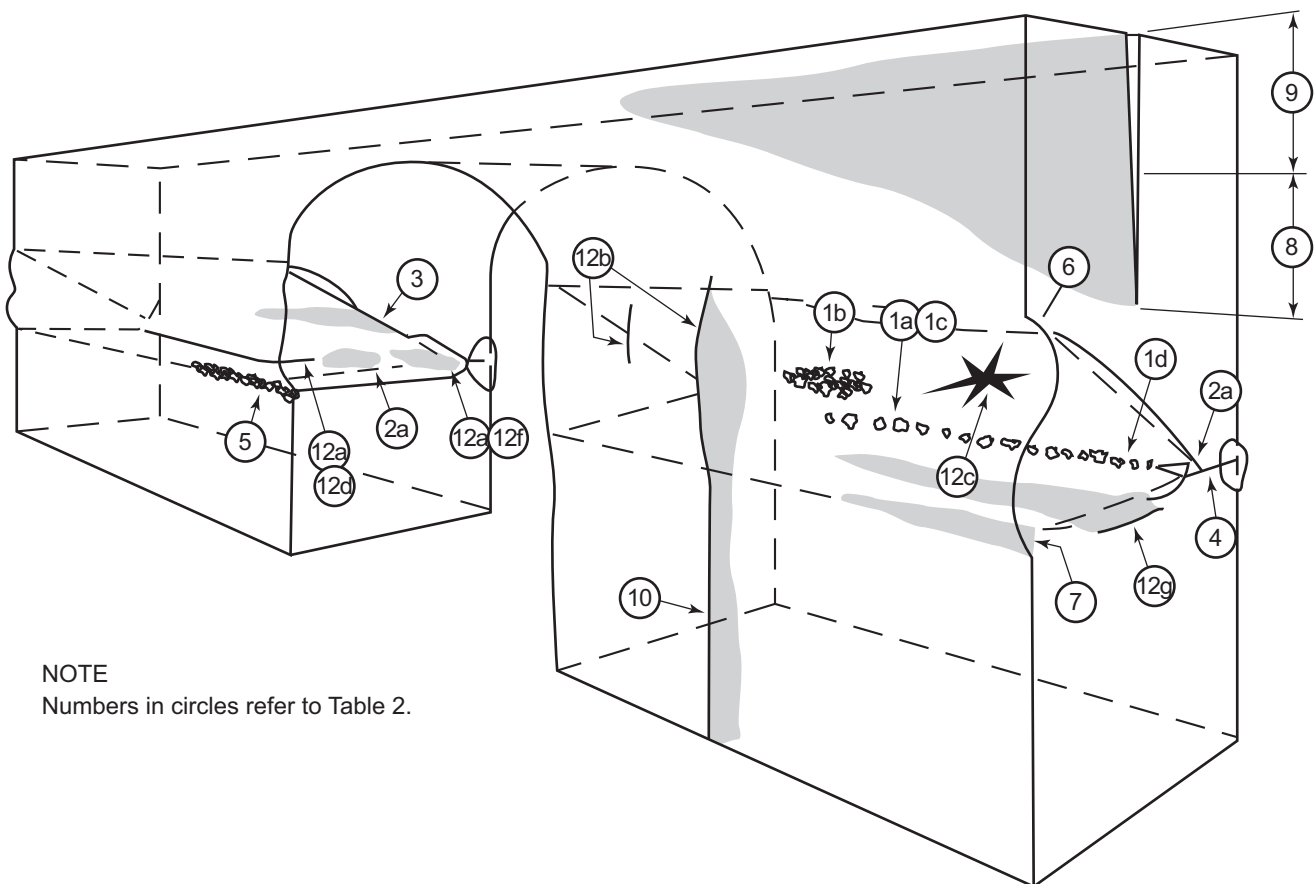

NOTE  
Numbers in circles refer to Table 2.

*AWS B1.10 Reprinted Courtesy of AWS.*

**Figure 13—Typical Discontinuities Present in a Single Bevel Groove Weld in a Butt Joint**

## 9.2 Materials Identification

During welding inspection, the inspector should verify the conformance of the base material and filler metal chemistries with the selected or specified alloyed materials. This should include reviewing the certified mill test report, reviewing stamps or markings on the components, or require PMI testing. It is the responsibility of the owner/user to establish a written material verification program indicating the extent and type of PMI to be as outlined in API 578.

**Table 4—Capability of the Applicable Inspection Method for Weld Type Joints**

Joints	Inspection Methods						
	RT	UT	PT	MT	VT	ET	LT
Butt	A	A	A	A	A	A	A
Corner	O	A	A	A	A	O	A
Tee	O	A	A	A	A	O	A
Lap	O	O	A	A	A	O	A
Edge	O	O	A	A	A	O	A

LEGEND  
 RT—Radiographic examination  
 UT—Ultrasonic examination  
 PT—Penetrant examination including both DPT (dye penetrant testing) and FPT (fluorescent penetrant testing)  
 MT—Magnetic particle examination  
 VT—Visual examination  
 ET—Electromagnetic examination  
 LT—Leak examination  
 A—Applicable method  
 O—Marginal applicability (depending on other factors such as material thickness, discontinuity size, orientation, and location)

From AWS B1.10. Reprinted Courtesy of AWS.

**Table 5—Capability of the Applicable Inspection Method vs. Discontinuity**

Discontinuities	Inspection Methods						
	RT	UT	PT <sup>a,c</sup>	MT <sup>b,c,d</sup>	VT <sup>a</sup>	ET	LT <sup>e</sup>
Porosity	A	O	A	O	A	O	A
Slag Inclusions	A	O	A	O	A		
Incomplete fusion	O	A	U	O	O	O	O
Incomplete joint penetration	A	A	U	O	O	O	U
Undercut	A	O	A	O	A	O	U
Overlap	U	O	A	A	O	O	U
Cracks	O	A	A	A	A	A	A
Laminations	U	A	A	A	A	U	U

LEGEND  
 RT—Radiographic testing  
 UT—Ultrasonic testing  
 PT—Penetrant testing including both DPT (dye penetrant testing) and FPT (fluorescent penetrant testing)  
 MT—Magnetic particle testing  
 VT—Visual testing  
 ET—Electromagnetic testing  
 LT—Leak examination  
 A—Applicable method  
 O—Marginal applicability (depending on other factors such as material thickness, discontinuity size, orientation, and location)  
 U—Usually not used

<sup>a</sup> Surface.  
<sup>b</sup> Surface and slightly subsurface.  
<sup>c</sup> Weld preparation or edge of base metal.  
<sup>d</sup> Magnetic particle examination is applicable only to ferromagnetic materials.  
<sup>e</sup> Leak testing is applicable only to enclosed structure which may be sealed and pressurized during testing.

From AWS B1.10. Reprinted Courtesy of AWS.

**Table 6—Discontinuities Commonly Encountered with Welding Processes**

Material	Type of Discontinuity	Welding Processes	Typical NDE Method	Practical Solution
Carbon Steel	Hydrogen Cracking	SMAW, FCAW, SAW	VT, PT, MT after cool down	Low-hydrogen electrode, preheat, post heat, clean weld joint.
	Lack of Fusion (LOF)	ALL	UT	Proper heat input, proper welding technique.
	Incomplete Penetration	ALL	RT, UT, VT <sup>a</sup>	Proper heat input, proper joint design.
	Undercut	SAW, SMAW, FCAW, GMAW	VT	Reduce travel speed.
	Slag Inclusion	SMAW, FCAW, SAW	RT, UT	Proper welding technique, cleaning, avoid excessive weaving.
	Porosity	ALL	RT	Low hydrogen, low sulfur environment, proper shielding.
	Burn-through	SAW, FCAW, GMAW, SMAW	RT, VT <sup>a</sup>	Proper heat input.
	Arc Strike	ALL	VT, MT, PT, Macroetch	Remove by grinding.
	Lack of side wall fusion	GMAW-S	UT	Proper heat input, vertical uphill.
	Tungsten Inclusion	GTAW	RT	Arc length control.
Austenitic Stainless Steel	Solidification cracking	ALL	PT	Proper filler, ferrite content, proper joint design.
	Hot cracking	SAW, FCAW, GMAW, SMAW	RT, PT, UT	Low heat input, stringer bead.
	Incomplete Penetration	ALL	RT, UT	Proper heat input.
	Undercut	SAW, SMAW, FCAW, GMAW	VT	Reduce travel speed.
	Slag Inclusion	SMAW, FCAW, SAW	RT, UT	Proper cleaning.
	Porosity	ALL	RT	Low hydrogen, low sulfur environment, proper shielding.
	Arc Strike	ALL	VT, PT, Macroetch	Remove by grinding.
	Tungsten Inclusion	GTAW	RT	Arc length control.

<sup>a</sup> When root is accessible

### 9.3 Visual Examination (VT)

#### 9.3.1 General

Visual examination is the most extensively used NDE method for welds. It includes either the direct or indirect observation of the exposed surfaces of the weld and base metal. Direct visual examination is conducted when access is sufficient to place the eye within 6 in. through 24 in. (150 mm through 600 mm) of the surface to be examined and at an angle not less than 30 degrees to the surface as illustrated in Figure 14. Mirrors may be used to improve the angle of vision.

Remote visual examination may be substituted for direct examination. Remote examination may use aids such as telescopes, borescopes, fiberscopes, cameras, or other suitable instruments, provided they have a resolution at least equivalent to that which is attained by direct visual examination. In either case, the illumination should be sufficient to allow resolution of fine detail. These illumination requirements are to be addressed in a written procedure.

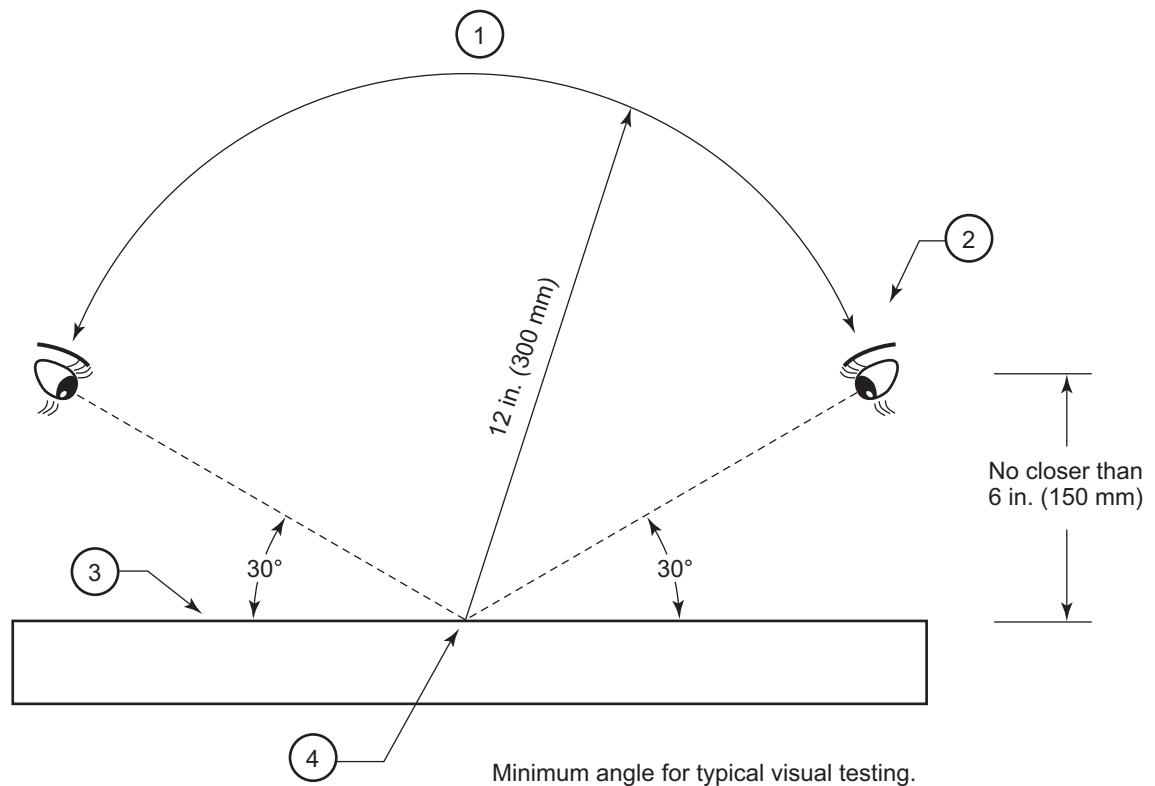

**Key**

- 1 viewing angle range
- 2 eye
- 3 test surface
- 4 test site

*Courtesy of CJ Heiller.*

**Figure 14—Direct Visual Examination Requirements**

ASME Section V, Article 9, lists requirements for visual examination. Codes and specifications may list compliance with these requirements as mandatory. Some requirements listed in this article include the following.

- a) A written procedure is required for examinations.
- b) The minimum amount of information that is to be included in the written procedure.
- c) Demonstration of the adequacy of the inspection procedure.
- d) Personnel are required to demonstrate annually completion of a J-1 Jaeger-type eye vision test.
- e) Direct visual examination requires access to permit the eye to be within 6 in. through 24 in. (150 mm through 600 mm) of the surface, at an angle not less than 30 degrees.
- f) The minimum required illumination of the part under examination.
- g) Indirect visual examination permits the use of remote visual examination and devices be employed.
- h) Evaluation of indications in terms of the acceptance standards of the referencing code.

## 9.3.2 Visual Inspection Tools

### 9.3.2.1 General

To visually inspect and evaluate welds, adequate illumination and good eyesight provide the basic requirements. In addition, a basic set of optical aids and measuring tools, specifically designed for weld inspection can assist the inspector. Listed below are some commonly used tools or methods with VT of welds.

### 9.3.2.2 Optical Aids

Optical aids used in visual inspection include the following.

- a) Lighting—the inspection surface illumination is of extreme importance. Adequate illumination levels should be established in order to ensure an effective visual inspection. Standards such as ASME Section V Article 9 specify lighting levels of 100 foot-candles (1000 lux) at the examination surface. This is not always easy to achieve so inspectors have to be keenly aware of the potential need to measure lighting conditions with light meters.
- b) Mirrors—valuable to the inspector allowing them to look inside piping, threaded and bored holes, inside castings and around corners if necessary.
- c) Magnifiers—helpful in bringing out small details and defects.
- d) Borescopes and Fiberscopes—widely used for examining tubes, a deep hole, long bores, and pipe bends, having internal surfaces not accessible to direct viewing.

### 9.3.2.3 Mechanical Aids

Mechanical aids used in visual inspection include the following.

- a) Steel ruler—available in a wide selection of sizes and graduations to suit the needs of the inspector (considered a non-precision measuring instrument).
- b) Vernier scale—a precision instrument, capable of measuring in decimal units to a precision factor of 0.0001 in. The Vernier system is used on various precision measuring instruments, such as the caliper, micrometer, height and depth gauges, gear tooth, and protractors.
- c) Combination square set—consisting of a blade and a set of three heads: Square, Center, and Protractor. Used universally in mechanical work for assembly and layout examination.
- d) Thickness gauge—commonly called a “Feeler” gauge is used to measure the clearance between objects.
- e) Levels—tools designed to prove if a plane or surface is truly horizontal or vertical.

### 9.3.2.4 Weld Examination Devices

Typical inspection tools for weld inspection include the following.

- a) Inspector’s kit (see Figure 15)—contains some of the basic tools needed to perform an adequate visual examination of a weld during all stages of welding. It includes everything from a lighted magnifier to a Vernier caliper.
- b) Bridge cam gauge (see Figure 16)—can be used to determine the weld preparation angle prior to welding. This tool can also be used to measure excess weld metal (reinforcement), depth of undercut or pitting, fillet weld throat size or weld leg length and misalignment (high-low).

- c) Fillet weld gauge—offers a quick and precise means of measuring the more commonly used fillet weld sizes. The types of fillet weld gauges include.
- 1) Adjustable fillet weld gauge (see Figure 17)—measures weld sizes for fit-ups with 45 degree members and welds with unequal weld leg lengths.
  - 2) Skew-T fillet weld gauge (see Figure 18)—measures the angle of the vertical member.
  - 3) The weld fillet gauge (see Figure 19)—a quick go/no-go gauge used to measure the fillet weld leg length. Gauges normally come in sets with weld leg sizes from  $\frac{1}{8}$  in. (3 mm) to 1 in. (25.4 mm). Figure 20 shows a weld fillet gauge being used to determine if the crown has acceptable concavity or convexity.
- d) Weld size gauge (see Figure 21)—measures the size of fillet welds, the actual throat size of convex and concave fillet welds, the reinforcement of butt welds and root openings.
- e) Hi-lo welding gauge (see Figure 22)—measures internal misalignment after fit-up, pipe wall thickness after alignment, length between scribe lines, root opening,  $37\frac{1}{2}$  degree bevel, fillet weld leg size and reinforcement on butt welds. The hi-lo gauge provides the ability to ensure proper alignment of the pieces to be welded. It also measures internal mismatch, weld crown height and root weld spacing.
- f) Digital pyrometer or temperature sensitive crayons—measures preheat and interpass temperatures.



Courtesy of G.A.I., Gage Co.

**Figure 15—Inspector's Kit**



Courtesy of G.A.I., Gage Co.

Figure 16—Bridge Cam Gauge

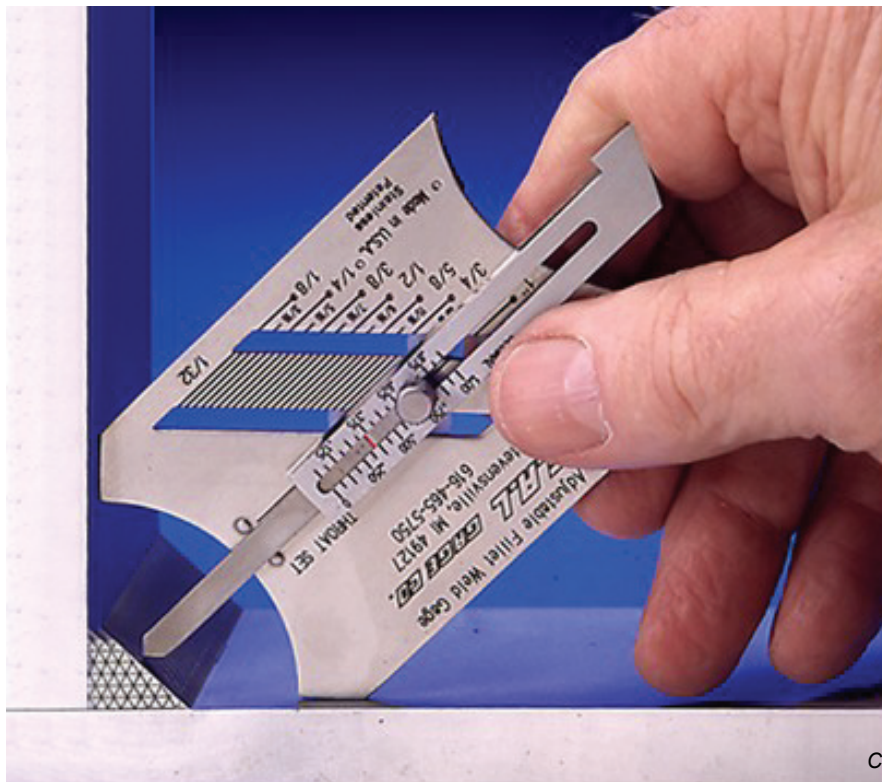

Courtesy of G.A.I., Gage Co.

Figure 17—Adjustable Fillet Weld Gauge

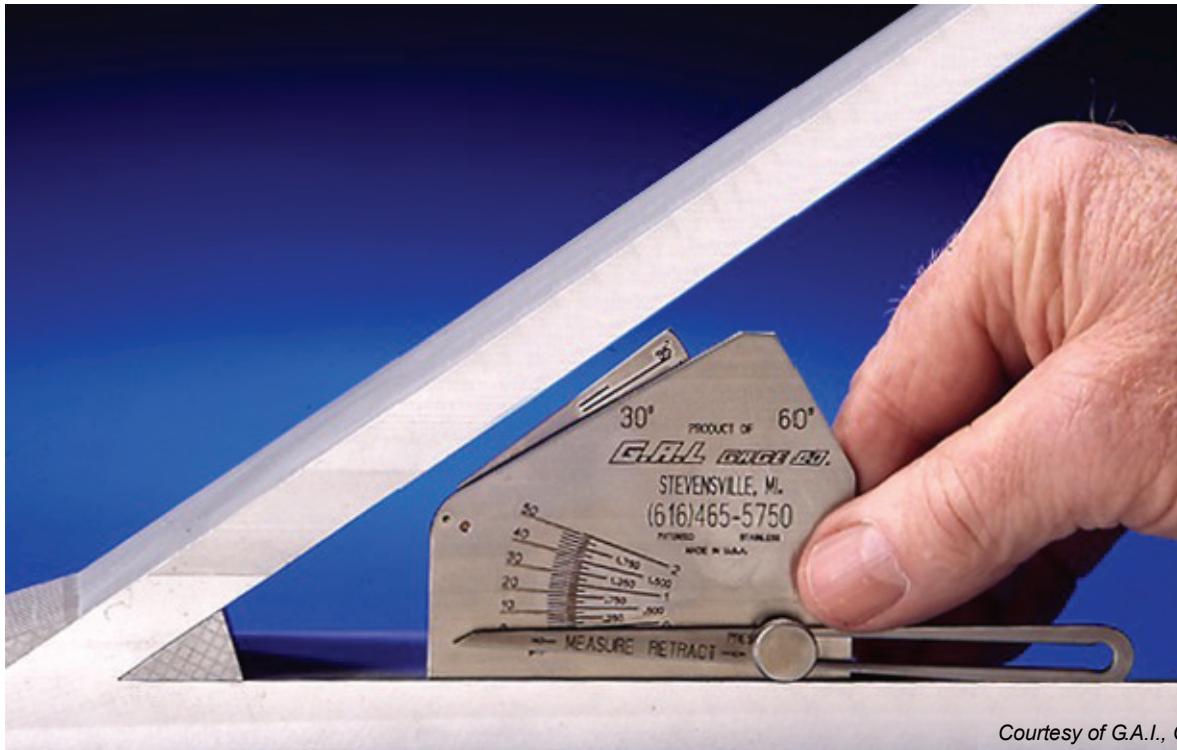

*Courtesy of G.A.I., Gage Co.*

**Figure 18—Skew—T Fillet Weld Gauge**

## 9.4 Magnetic Particle Examination (MT)

### 9.4.1 General

Magnetic particle examination is effective in locating surface or near surface discontinuities of ferromagnetic materials. It is most commonly used to evaluate weld joint surfaces, intermediate checks of weld layers and back-gouged surfaces of the completed welds. Typical types of discontinuities that can be detected include cracks, laminations, laps, and seams.

In this process, the weld (and heat-affected zone) is locally magnetized, creating a magnetic field in the material. Ferromagnetic particles are then applied to the magnetized surface and are attracted to any breaks in the magnetic field caused by discontinuities as shown in Figure 23 and Figure 24.

Figure 23 shows the disruption to the magnetic field caused by a defect open to the surface. Ferromagnetic particles are drawn to the break in the flux field. The pattern of the particles is very sharp and distinct. Figure 24 illustrates how a sub-surface defect would also disrupt the magnetic lines of flux. The observed indication would not be as clearly defined, as would a defect open to the surface. The pattern formed by the particles represents the shape and size of any existing discontinuities as seen in Figure 25. The particles used during the exam can be either dry or wet. If the examination is performed in normal lighting the color of the particles should provide adequate contrast with the exam surface. The best results are achieved when the lines of flux are perpendicular to the discontinuity. Typically, two inspections are performed, one parallel to the weld and one across the weld to provide the maximum coverage. When a magnetic force is applied to the material, a magnetic flux field is created around and through the material. Discontinuities that are perpendicular to the lines of flux attract the magnetic particles causing an indication as shown in Figure 26. Figure 27 illustrates the setup for detecting transverse indications. The yoke is placed parallel on the weld to detect discontinuities transverse to the weld. Figure 28 shows the setup for detecting indications that run parallel to the weld. In this case, the yolk is placed across the weld to detect discontinuities parallel to the weld.



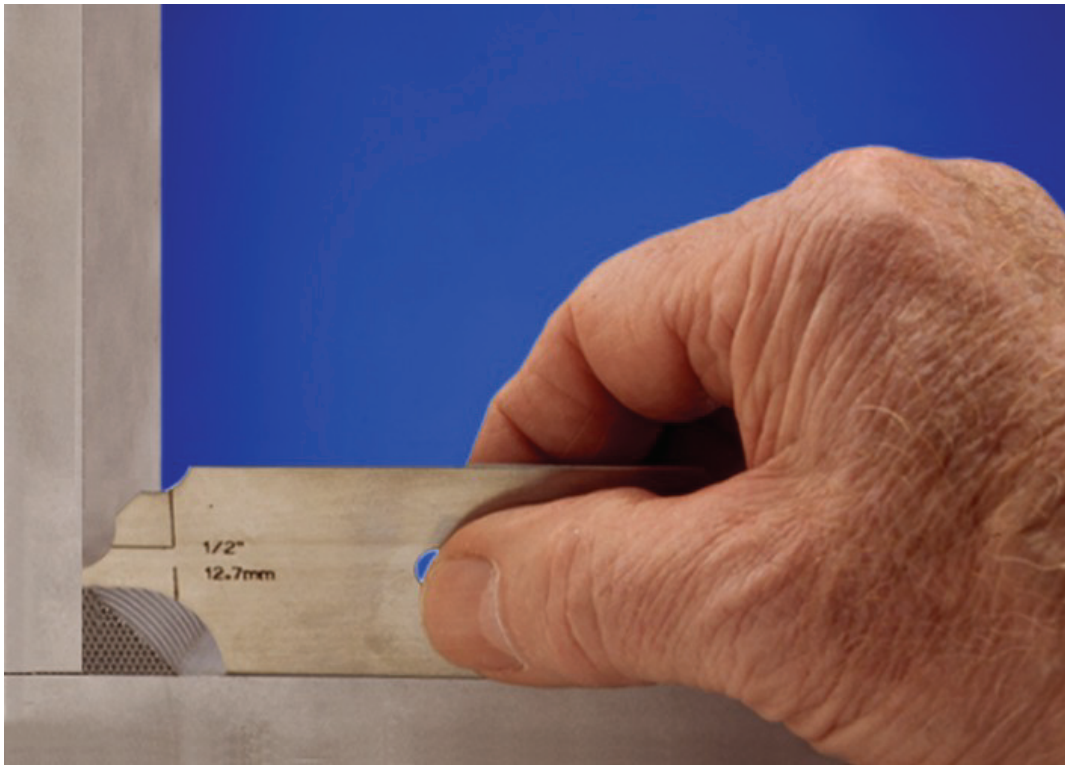

Courtesy of G.A.I., Gage Co.

Figure 19—Weld Fillet Gauge



Courtesy of G.A.I., Gage Co.

Figure 20—Weld Fillet Gauge

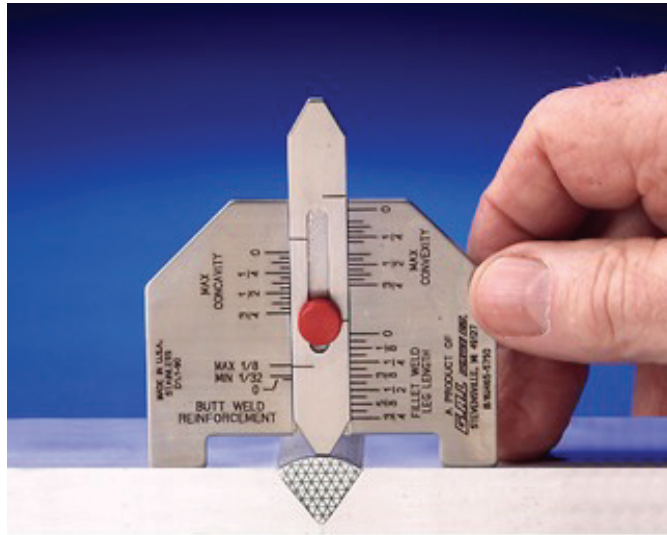

Courtesy of G.A.I., Gage Co.

Figure 21—Weld Size Gauge

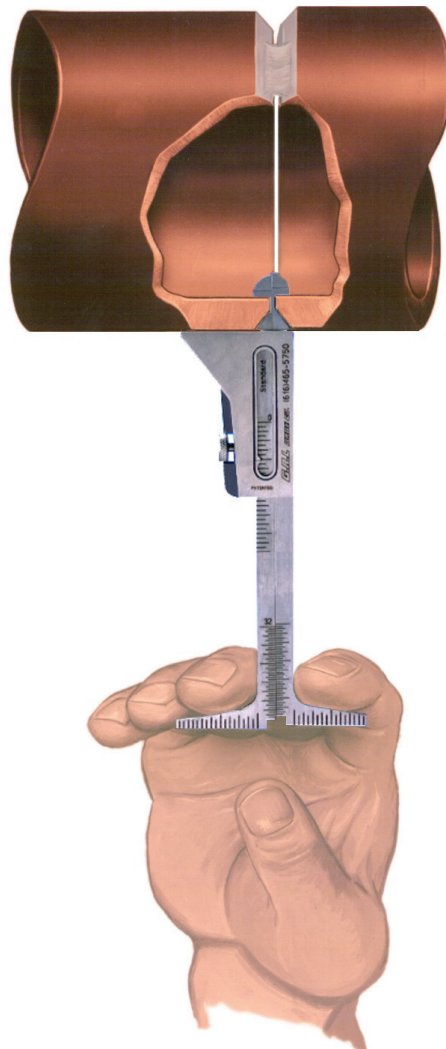

Courtesy of G.A.I., Gage Co.

Figure 22—Hi-Lo Gauge

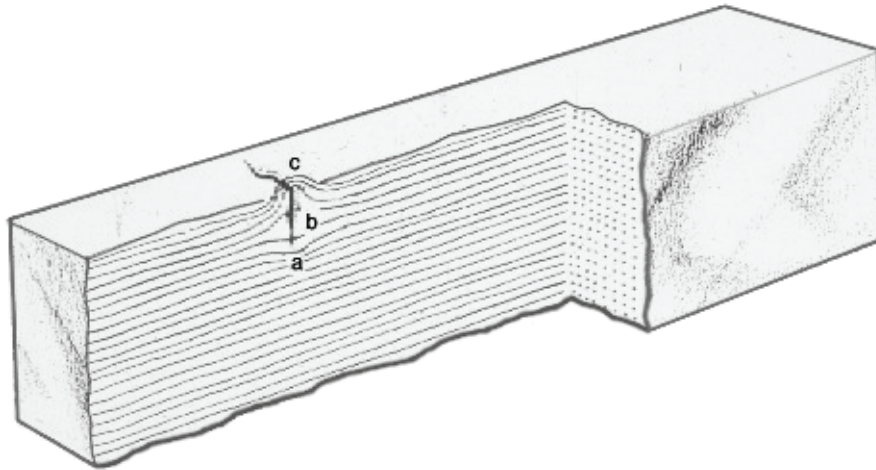

*Courtesy of CJ Hellier*

**Figure 23—Surface-breaking Discontinuity**

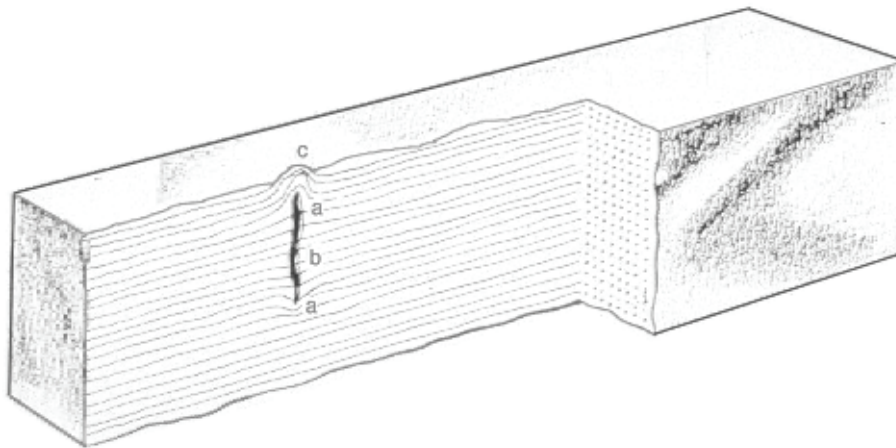

*Courtesy of CJ Hellier*

**Figure 24—Subsurface Discontinuity**

For added sensitivity, wet fluorescent magnetic particle (WFMT) techniques may be used. With this technique, a filtered blacklight is used to observe the particles, which requires the area of testing be darkened.

ASME Section V, Article 7, lists requirements for magnetic particle examination. Some codes and specifications may list compliance with these requirements as being mandatory. ASME B31.3 and ASME Section VIII, Division 1, requires magnetic particle examination be performed in accordance with Article 7. Some of the requirements listed in this article include:

- a) examination procedure information;
- b) use of a continuous method;
- c) use of one of five magnetization techniques;



- d) required calibration of equipment;
- e) two examinations perpendicular to each other;
- f) maximum surface temperature for examination;
- g) magnetization currents;
- h) evaluation of indications in terms of the acceptance standards of the referencing code;
- i) demagnetization;
- j) minimum required surface illumination (visible or blacklight) of the part under examination.

### 9.4.2 Magnetic Flux Direction Indicator

The direction of the magnetic flux direction can be confirmed by the use of several indicators. One of the most popular indicators is the pie gauge. It consists of eight low-carbon steel segments, brazed together to form an octagonal plate that is copper plated on one side to hide the joint lines (see Figure 29). The plate is placed on the test specimen, adjacent to the weld, during magnetization with the copper side up. The particles are applied to the copper face and outline the orientation of the resultant field.

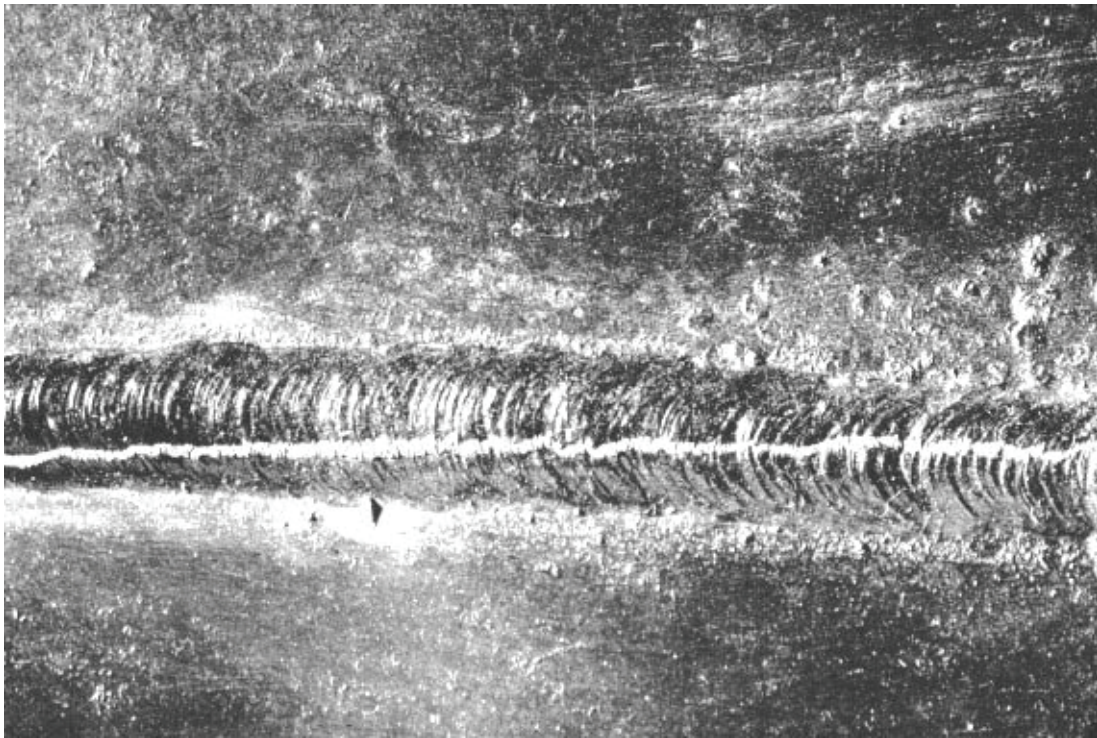

*Courtesy of CJ Hellier*

**Figure 25—Weld Discontinuity**

### 9.4.3 Demagnetization

When the residual magnetism in the part could interfere with subsequent processing or usage, demagnetization techniques should be used to reduce the residual magnetic field to within acceptable limits. Care should be taken when performing MT examination of a weld during the welding process. If a residual field is left in a partially completed weld, this field may deflect the weld arc and make it difficult to control the weld deposit.

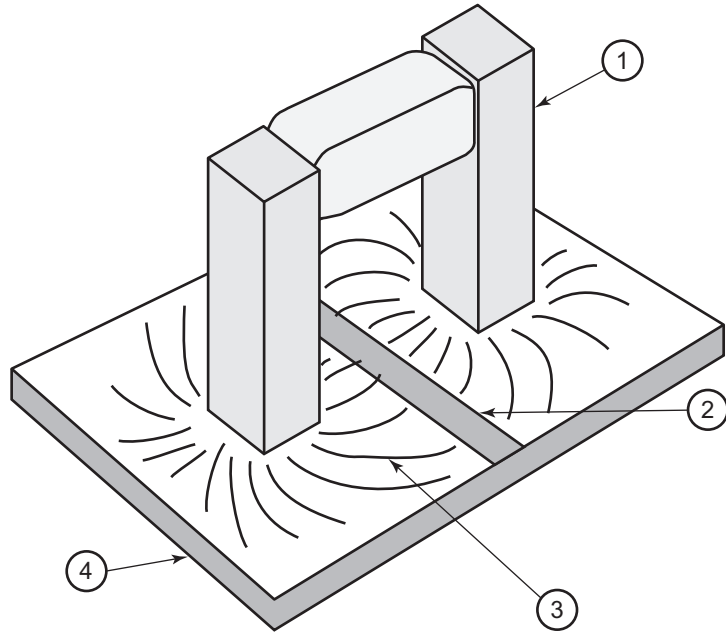

- Key**  
1 yoke  
2 weld  
3 flux lines  
4 test part

*Courtesy of CJ Hellier*

**Figure 26—Flux Lines**

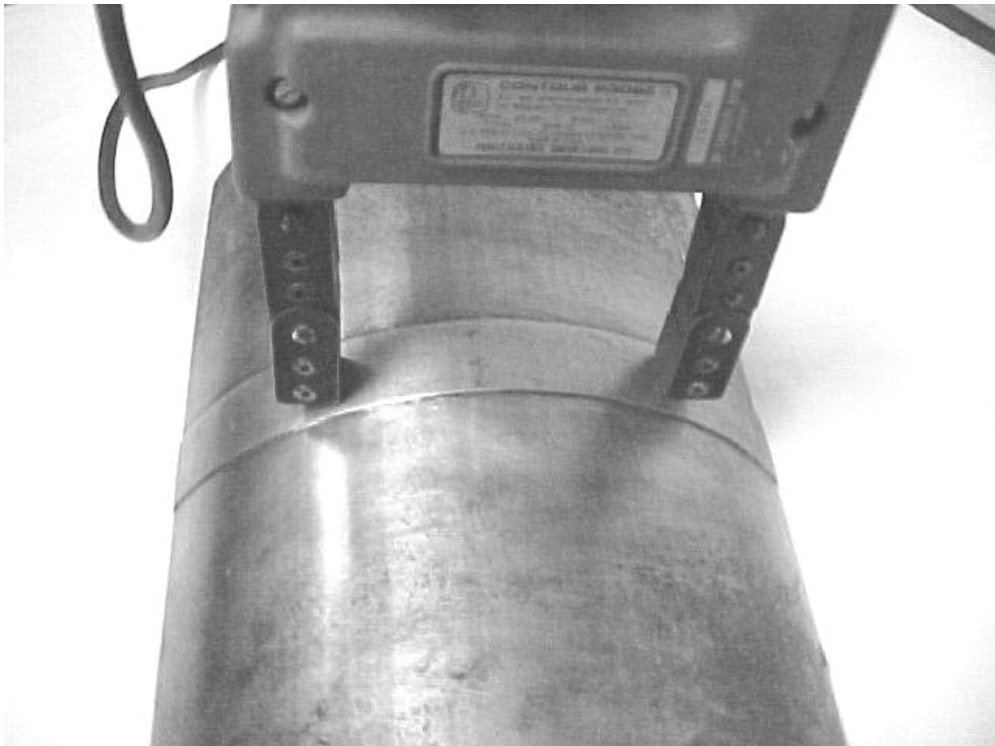

*Courtesy of CJ Hellier*

**Figure 27—Detecting Discontinuities Transverse to Weld**

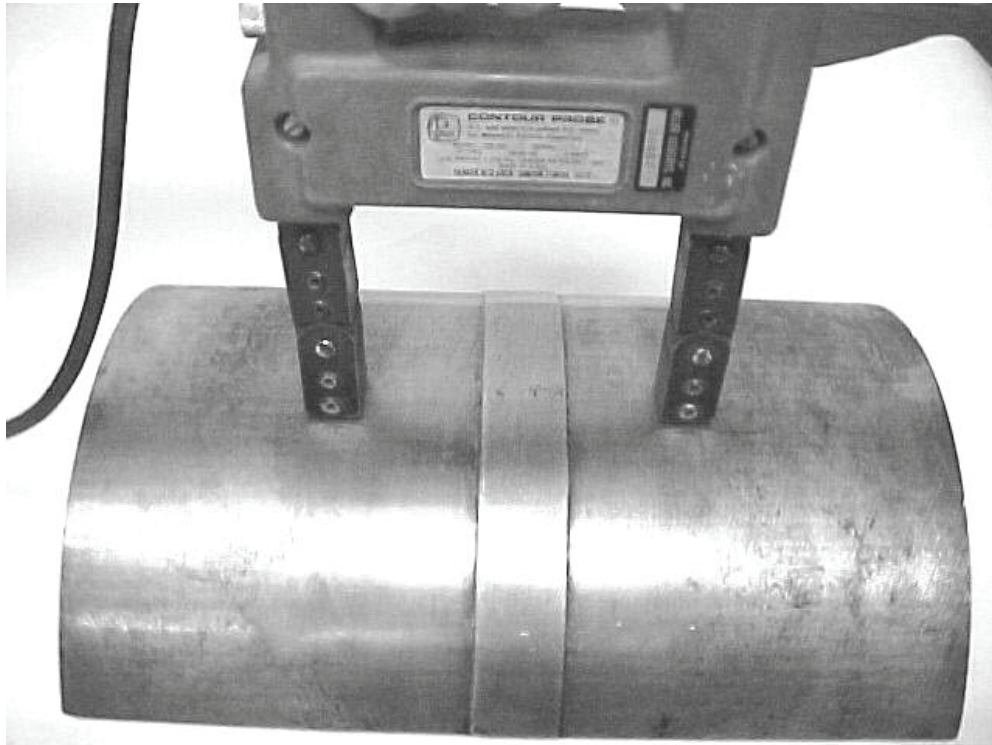

*Courtesy of CJ Hellier*

**Figure 28—Detecting Discontinuities Parallel to the Weld**

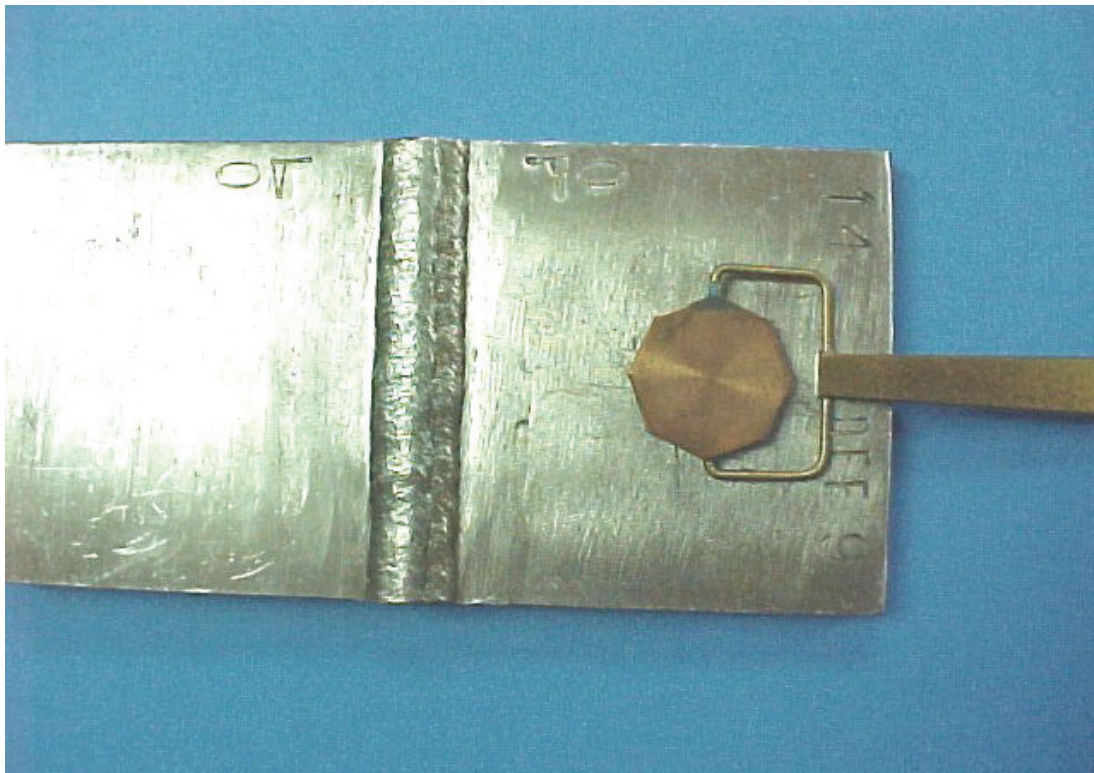

**Figure 29—Pie Gauge**



## 9.5 Alternating Current Field Measurement (ACFM)

The ACFM technique is an electromagnetic non-contacting technique that is able to detect and size surface breaking defects in a range of different materials and through coatings of varying thickness. This technique can be used for inspecting complex geometries such as nozzles, ring-grooves, and grind-out areas. It requires minimal surface preparation and can be used at elevated temperatures up to 900 °F (482 °C). However, it is less sensitive and more prone to operator errors than WFMT. ACFM is used for the evaluation and monitoring of existing cracks.

ACFM uses a probe similar to an eddy current probe and introduces an alternating current in a thin skin near to the surface of any conductor. When a uniform current is introduced into the area under test, if it is defect free, the current is undisturbed. If the area has a crack present, the current flows around the ends and the faces of the crack. A magnetic field is present above the surface associated with this uniform alternating current and becomes disturbed if a surface-breaking crack is present.

The probe is scanned longitudinally along the weld with the front of the probe parallel and adjacent to the weld toe. Two components of the magnetic field are measured:  $B_x$  along the length of the defect, which responds to changes in surface current density and gives an indication of depth when the reduction is the greatest; and  $B_z$ , which gives a negative and positive response at either end of the defect caused by current-generated poles providing an indication of length. A physical measurement of defect length indicated by the probe position is then used together with a software program to determine the accurate length and depth of the defect.

During the application of the ACFM technique actual values of the magnetic field are being measured in real time. These are used with mathematical model look-up tables to eliminate the need for calibration of the ACFM instrument using a calibration piece with artificial defects such as slots.

## 9.6 Liquid Penetrant Examination (PT)

### 9.6.1 General

PT is capable of detecting surface-connecting discontinuities in ferrous and nonferrous alloys. Liquid penetrant examination can be used to examine the weld joint surfaces, intermediate checks of individual weld passes, and completed welds. PT is commonly employed on austenitic stainless steels where magnetic particle examination is not possible. The examiner should recognize that many specifications limit contaminants in the penetrant materials which could adversely affect the weld or parent materials. Most penetrant manufacturers provide material certifications on the amounts of contaminants (e.g. chlorine, sulfur, and halogens).

A limitation of PT is that standard penetrant systems are limited to a maximum of 125 °F (52 °C) so the weld must be cool which significantly slows down the welding operation. High-temperature penetrant systems can be qualified to extend the temperature envelope.

During PT, the test surface is cleaned and coated with a penetrating liquid that seeks surface-connected discontinuities. After the excess surface liquid penetrant is removed, a solvent-based powder suspension (developer) is normally applied by spraying. The liquid in any discontinuity bleeds out to stain the powder coating. An indication of depth is possible if the Inspector observes and compares the indication bleed out to the opening size visible at the surface. The greater the bleed out to surface opening ratio, the greater the volume of the discontinuity.

### 9.6.2 Liquid Penetrant Techniques

The two general penetrant techniques approved for use include the color contrast penetrant technique (normally red in color to contrast with a white background) and the fluorescent penetrant technique, which uses a dye that is visible to ultraviolet light, as shown in Figure 30. For added sensitivity, fluorescent penetrant techniques may be used to detect fine linear type indications. The examination is performed in a darkened area using a filtered blacklight.

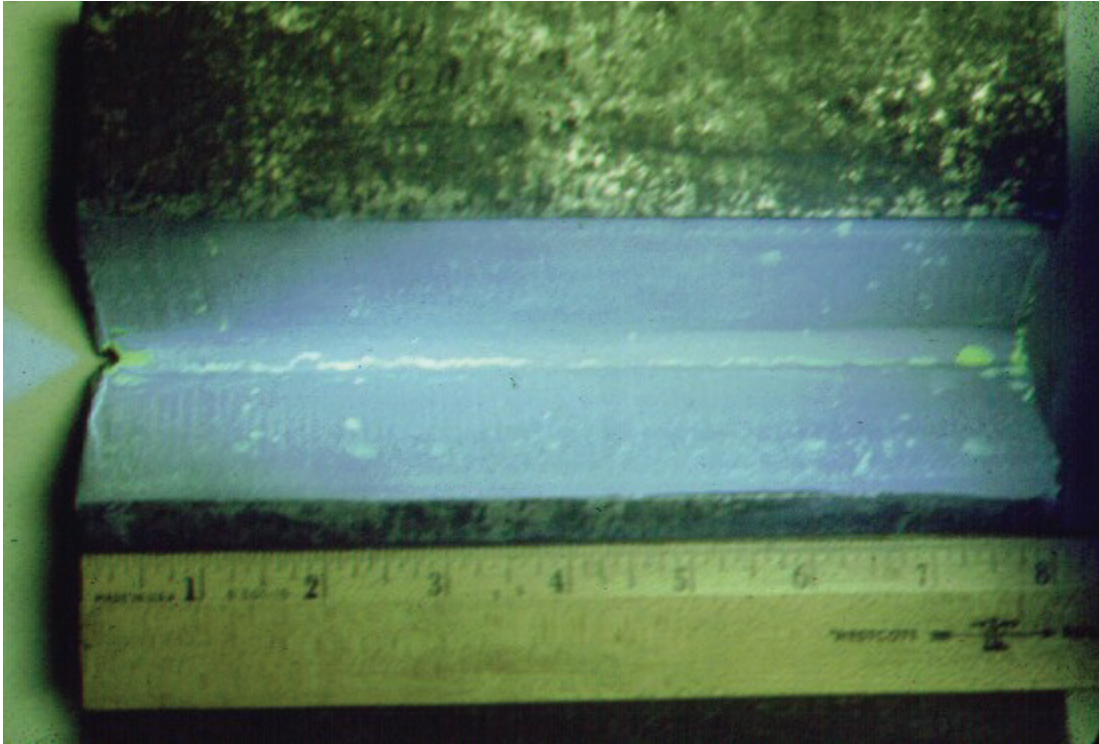

**Figure 30—Fluorescent Penetrant Technique**

Three different penetrant systems are available for use with both of the techniques, they include:

- a) solvent removable;
- b) water washable;
- c) post emulsifiable.

Compatibility with base metals, welds, and process material should be considered before penetrants are used, since they can be difficult to remove completely.

ASME Section V, Article 6, (Paragraph T-620) lists general requirements for liquid penetrant examination. Codes and specifications may list compliance with these requirements as mandatory. API Standard 650, ASME B31.3 and ASME Section VIII, Division 1, require liquid penetrant examination be performed in accordance with Article 6. Some requirements listed in this article include:

- a) inspection is to be performed in accordance with a procedure (as specified by the referencing code section);
- b) type of penetrant materials to be used;
- c) details for pre-examination cleaning including minimum drying time;
- d) dwell time for the penetrant;
- e) details for removing excess penetrant, applying the developer, and time before interpretation;
- f) evaluation of indications in terms of the acceptance standards of the referencing code;

- g) post examination cleaning requirements;
- h) minimum required surface illumination (visible or blacklight) of the part under examination.

## 9.7 Eddy Current Examination (ET)

Eddy current inspection is used to detect surface discontinuities, and in some cases subsurface discontinuities in tubing, pipe, wire, rod and bar stock. ET has limited use in weld inspection. Eddy current can be used as a quick test to ensure that the components being joined during welding have the same material properties, and as a quick check for defects of the weld joint faces. It can also be used to measure the thickness of protective, nonconductive surface coatings and measure cladding thickness.

Eddy current uses a magnetic field to create circulating currents in electrically conductive material. Discontinuities in the material alter the magnetically induced fields and present them on the unit's display. As with the magnetic particle inspection, this technique is most sensitive for defect detection when the currents are perpendicular to the discontinuity.

More information can be found in ASME Section V, Article 8, which addresses eddy current examination of tubular products.

## 9.8 Radiographic Examination (RT)

### 9.8.1 General

RT is a volumetric examination method capable of examining the entire specimen rather than just the surface. It is the historical approach to examine completed welds for surface and subsurface discontinuities. The method uses the change in absorption of radiation by solid metal and in ~~an~~ areas of a discontinuity. The radiation transmitted reacts with the film, a latent image is captured, and when the film is processed (developed) creates a permanent image (radiograph) of the weld. Some methods are available which use electronics to create a digital image and are referred to as "filmless." Due to the hazard of radiation, and the licensing requirements, the cost can be higher and the trained and certified personnel more limited, than with other NDE methods.

An NDT examiner interprets and evaluates the radiographs for differences in absorption and transmission results. Radiographic indications display a different density as contrasted with the normal background image of the weld or part being inspected. The radiographer also makes sure that the film is exposed by the primary source of the radiation and not backscatter radiation.

The NDT examiner that performs the film interpretation, evaluation and reporting should be certified as a minimum to ASNT Level II requirements. However, all personnel performing radiography are required to attend radiation safety training and comply with the applicable regulatory requirements.

ASME Section V, Article 2, paragraph T-220 lists the general requirements for radiographic examination. There are very specific requirements with regard to the quality of the produced radiograph, including the sharpness of the image, the ability to prove adequate film density in the area of interest and sensitivity to the size and type of expected flaws. Requirements listed in Article 2 include:

- a) method to determine if backscatter is present;
- b) permanent identification, traceable to the component;
- c) film selection in accordance with SE-1815;
- d) designations for hole or wire type image quality indicators (penetrameters);

- e) suggested radiographic techniques;
- f) facilities for viewing radiographs;
- g) calibration (certification of source size).

The exposure and processing of a radiograph is considered acceptable when it meets the required quality features in terms of sensitivity and density. These factors are designed to ensure that imperfections of a dimension relative to section thickness are revealed.

### 9.8.2 Image Quality Indicators (Penetrameters)

Standards for industrial radiography require the use of one or more image quality indicators (IQIs) to determine the required sensitivity is achieved. The IQI was previously called a penetrameter but this term is no longer being used in most codes. To assess sensitivity the required hole or wire as specified by the governing code must be visible on the finished radiograph. Mistakes with IQIs (penetrameters) can have much greater impact on thinner wall pipe where large root pass imperfections can significantly reduce the strength and integrity of a weld.

IQIs (penetrameters) are tools used in industrial radiography to establish the quality level of the radiographic technique. IQIs (penetrameters) are selected based on the following.

- a) Material being radiographed. The IQI must be made from the same alloy material group or one with less radiation absorption.
- b) Thickness of the base material plus reinforcement. The thickness of any backing ring or strip is not a consideration in IQI selection.

There are two types of IQIs (penetrameters) in use today.

- 1) Wire-type IQIs (penetrameters) are constructed of an array of six paralleled wires of specified diameters. They are made of substantially the same material as the component being radiographed. Wire-type IQIs (penetrameters) are placed on and perpendicular to the weld prior to the exposure of a radiograph. The diameter of the smallest wire that is visible as a lighter-white image on the radiograph provides an indication of the sensitivity of the radiograph. The wire that is to be visible on an acceptable radiograph is known as the essential wire and it is specified by the standard. Wire-type IQIs (penetrameters) are most often placed perpendicular to the center line of the weld with the required sensitivity based on the weld thickness.
- 2) Hole-type IQIs (penetrameters) are strips of metal of known thickness with holes of a specified diameter drilled or punched through the sheet. They are made of substantially the same material as the component being radiographed. The thickness of hole-type IQIs (penetrameters) are generally specified to represent approximately two to four percent of the thickness of the object being radiographed. The holes in the IQI (penetrameter) are projected on a radiograph as darker (black or gray) spots. The thickness of the IQI (penetrameter) and the diameter of the smallest hole that is visible as a darker image on the radiograph provide an indication of the sensitivity of the radiograph. The diameter of holes in hole-type IQIs (penetrameters) are a multiple of the thickness of the sheet. Common hole diameters are one, two and four times the thickness (1T, 2T, and 4T) of the IQI (penetrameter), as shown in Figure 31. Hole-type IQIs (penetrameters) are placed adjacent to the weld either on the parent material or on a shim having a thickness equivalent to the weld build-up.

For pipe wall or weld thickness of 0.312 in. (7.9 mm), a No. 15 ASTM IQI (penetrameter) with a thickness of 0.015 in. (0.38 mm) as shown in Figure 32 would be used. See Table 7 for IQI (penetrameter) numbers for other thicknesses. This table illustrates the specified thickness and number of ASTM E94 IQIs (penetrameters) for all thickness ranges. It summarizes the essential hole diameter requirements for hole-type IQIs (penetrameters).

The hole that is required to be visible on an acceptable radiograph is called the essential hole. Each size of hole-type IQIs (penetrameters) are identified by a number that is related to the sheet thickness in inches. For example, a No. 10 IQI (penetrameter) is 0.010 in. (0.25 mm) thick while a No. 20 is 0.020 in. thick (0.51 mm).

### 9.8.3 Radiographic Film

Radiographic film Class I or II are acceptable for use. The film is required to be of a sufficient length and width to allow a minimum of 1 in. (25 mm) on consecutive circumferential exposures, and 3/4 in. (19 mm) coverage on either side of the weld. Film should be stored in a cool, dry, clean area away from the exposure area where the emulsion is not affected by heat, moisture and radiation.

**Table 7—ASTM E94 IQIs (Penetrameters)**

Pipe Wall or Weld Thickness in. (mm)	No.	Essential Hole Diameter in. (mm)
0 to 0.250 (0 to 5.6)	12	0.025 (0.63)
> 0.250 to 0.375 (5.8 to 9.5)	15	0.030 (0.76)
> 0.375 to 0.500 (9.5 to 12.7)	17	0.035 (0.89)
> 0.500 to 0.750 (12.7 to 19.0)	20	0.040 (1.02)
> 0.750 to 1.000 (19.0 to 25.4)	25	0.050 (1.27)
> 1.000 to 2.000 (25.4 to 50.8)	30	0.060 (1.52)

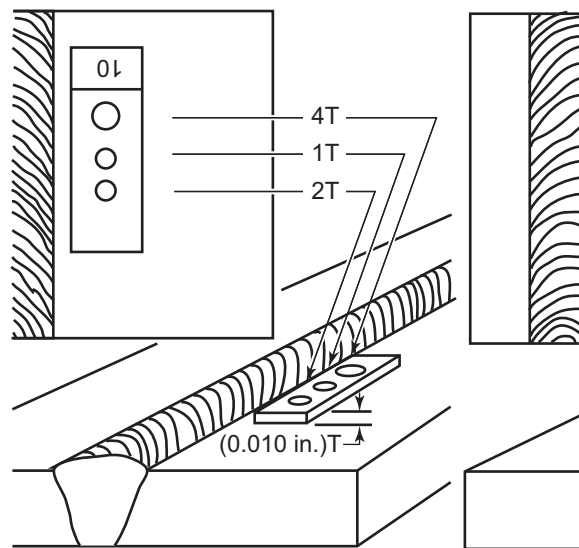

**Figure 31—IQI (Penetrameter) Common Hole Diameters**

### 9.8.4 Radioactive Source Selection

For weld inspection, typically radioactive isotopes of Iridium 192 or Cobalt 60 are used. X-ray machines may also be used. Iridium 192 is normally used for performing radiography on steel with a thickness range of 0.25 in. to 3.0 in. (6.3 mm to 76.2 mm). Cobalt 60 is used for steel thickness of 1.5 in. to 7.0 in. (38 mm to 178 mm). The minimum or maximum thickness that can be radiographed for a given material is determined by demonstrating that the required sensitivity has been obtained.





Figure 32—IQI (Penetrameter)

### 9.8.5 Film Processing

Exposed film can either be hand-processed, or the examiner may use an automatic processor. Normal developing time is five to eight minutes at 68 °F (20 °C). When the temperature is higher or lower, the developing time is adjusted such that the processing consistently produces radiographs of desired quality. The chemicals used in processing, developer, fixer and rinse water are changed on a regular basis or at any time that processed film shows chemical irregularities.

### 9.8.6 Surface Preparation

Where a surface condition, which could mask a defect, is visually detected by the radiographer prior to radiography, the surface condition should be remedied prior to the exposure. Weld ripples or other irregularities on both the inside, where accessible, or on the outside, should be removed to the degree that the resulting image does not have indications that can either mask or be confused with the image of a discontinuity.

### 9.8.7 Radiographic Identification

The identification information on all radiographs should be plainly and permanently produced, traceable to contract, manufacturer, date, and to component, weld or weld seam or part numbers as appropriate and should not obscure any area of interest. Location markers should also appear on the film identifying the area of coverage.

### 9.8.8 Radiographic Techniques

#### 9.8.8.1 General

The most effective technique is one in which the radiation passes through a single thickness of the material being radiographed and the film is in contact with the surface opposite the source side. Other techniques may be used as the referencing code or situation dictates. Regardless of the technique used, the goal is to achieve the highest possible quality level. The IQI (penetrameter) placement should be as close to the weld as possible without interfering with the weld image.

A technique should be chosen based upon its ability to produce images of suspected discontinuities, especially those that may not be oriented in a favorable direction to the radiation source. Radiography is extremely sensitive to the orientation of tight planar discontinuities. If a tight planar discontinuity is expected to be at an angle to the source of the radiation, it may be difficult or impossible to detect. The nature, location, and orientation should always be a major factor in establishing the technique.

#### 9.8.8.2 Single-wall Technique

A single-wall exposure technique should be used for radiography whenever practical. In the single-wall technique, the radiation passes through only one wall of the material or weld, which is viewed for acceptance on the radiograph (see

Figure 33). An adequate number of exposures should be made to demonstrate that the required coverage has been obtained.

### 9.8.8.3 Single-wall Viewing

For materials, and for welds in components, a technique may be used in which the radiation passes through two walls and only the weld (material) on the film sidewall is viewed for acceptance. An adequate number of exposures should be made to demonstrate that the required coverage is met for circumferential welds (materials). A minimum of three exposures taken at 120 degrees to each other should be made.

### 9.8.8.4 Double-wall Technique

When it is not practical to use a single wall technique, a double-wall technique should be used.

For materials and for welds in components 3.5 in. (88.9 mm) or less in nominal outside diameter, a technique may be used in which the radiation passes through two walls and the weld (material) in both walls is viewed for acceptance on the same radiograph. For double-wall viewing of welds, the radiation beam may be offset from the plane of the weld at an angle sufficient to separate the images of the source side portions and the film side portions of the weld so there is no overlap of the areas to be interpreted (see Figure 34). When complete coverage is required, a minimum of two exposures taken at 90 degrees to each other should be made of each weld joint.

Alternatively, the weld may be radiographed with the radiation beam positioned such that both walls are superimposed. When complete coverage is required, a minimum of three exposures taken at either 60 degrees or 120 degrees to each other should be made for each weld joint.

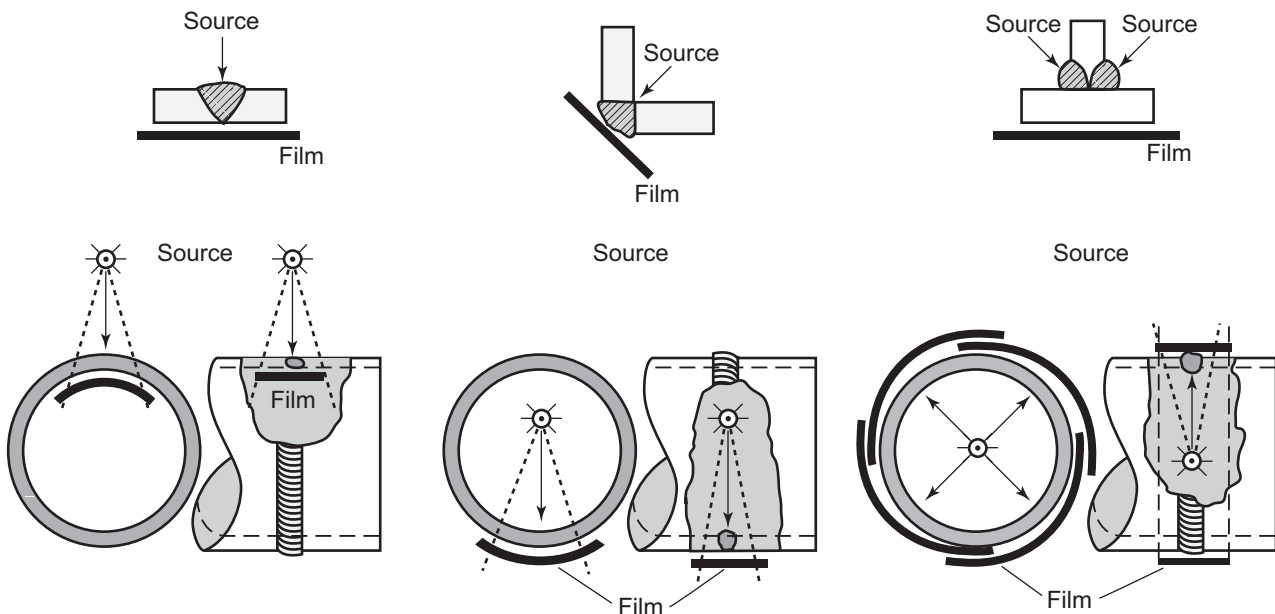
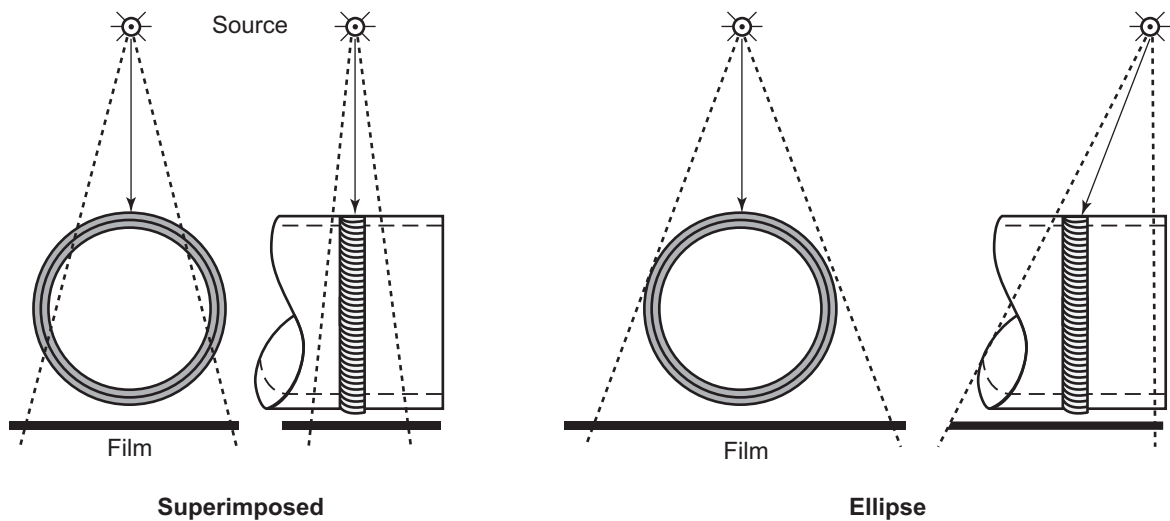

Figure 33—Single-wall Techniques

## 9.8.9 Evaluation of Radiographs

### 9.8.9.1 General

The final step in the radiographic process is the evaluation of the radiograph. Accurate film interpretation is essential; it requires hours of reviewing and the understanding of the different types of images and conditions associated in industrial radiography. The interpreter should be aware of different welding processes and the discontinuities



*Courtesy of Charles J. Heller*

**Figure 34—Double-wall Techniques**

associated with those processes. The various discontinuities found in weldments may not always be readily detectable. For example, rounded indications such as porosity, slag and inclusions are more apparent than an indication compared to a crack, lack of fusion or overlap. A weld crack is generally tight and not always detectable by radiography unless their orientation is somewhat in the same plane as the direction of the radiation. Lack of fusion is typically narrow and linear and it tends to be straighter than a crack. In many cases lack of fusion is located at the weld bevel angle or between two subsequent weld bead passes. This may add to the degree of difficulty in identifying this condition.

### 9.8.9.2 Facilities for Viewing Radiographs

Viewing facilities need to provide subdued background lighting of an intensity to avoid troublesome reflections, shadows, or glare on the radiograph. Equipment used to view radiographs for interpretation needs to provide a light source sufficient for the essential IQI (penetrameter) hole or wire to be visible for the specified density range. The viewing conditions should be such that the light from around the outer edge of the radiograph or coming through low-density portions of the radiographs does not interfere with the interpretation. Low power magnification devices (1.5X to 3X) may also be used to aid in film interpretation and evaluation; but too high of a magnification also enhances the graininess of the film. For example, comparators with scales etched into the glass offer magnification and measuring capabilities.

### 9.8.9.3 Quality of Radiographs

Radiographs should be free from mechanical, chemical or other blemishes to the extent that they do not mask, and are not confused with the image of any discontinuity in the area of interest. A radiograph with any blemishes in the area of interest should be discarded and the area radiographed again.

Definition of the area of interest is often commonly misunderstood and the subject of confusion. Many of the common codes and standards in the hydrocarbon industry do not actually define the area of interest which leads to misalignment between inspectors and fabricators. ASTM E1316 states “the specific portion of a radiograph that needs to be evaluated”. This is the approach inspectors generally prefer, and gives the inspector the final decision to identify the area of interest. ASME Section XI for the nuclear industry has a more practical guidance of  $1t$  where  $t$  is the nominal thickness of the component being joined. This provides a minimum recommended guidance for inspectors reviewing radiographs.

#### 9.8.9.4 Radiographic Density

Film density is the quantitative measure of film blackening as a result of exposure and processing. Clear film has a zero density value. Exposed film that allows 10 % of the incident light to pass through has a 1.0 film density. A film density of 2.0, 3.0, and 4.0 allows 1 %, 0.1 % and 0.01 % of the incident light to pass through respectively.

The transmitted film density through the radiographic image through the body of the hole type IQI (penetrameter), or adjacent to the wire IQI (penetrameter), in the area of interest should be within the range 1.8 to 4.0 for x-ray and 2.0 to 4.0 for Gamma Ray. Adequate radiographic density is essential; rejectable conditions in a weld may go unnoticed if slight density variations in the radiographs are not observed.

A densitometer or step wedge comparison film is used to measure and estimate the darkness (density) of the film. A densitometer is an electronic instrument calibrated using a step tablet or step wedge calibration film traceable to a national standard. The step wedge comparison film is a step wedge that has been calibrated by comparison to a calibrated densitometer.

The base density of the radiograph is measured through the IQI (penetrameter). A number of density readings should be taken at random locations in the area of interest (excluding areas having discontinuities). The density range in the area of interest must not vary greater or less than a specified percentage of the base density as defined in the code or specification.

#### 9.8.9.5 Excessive Backscatter

Radiation that passes through the object and film can be reflected back towards the film (i.e. a phenomenon termed 'backscatter'). A lead letter "B" with a minimum dimension of  $\frac{1}{2}$  in. (12.7 mm) and  $\frac{1}{16}$  in. (1.55 mm) thickness is typically attached to the back of each film holder/cassette during each exposure to determine if backscatter radiation is exposing the film. If a light image of the letter "B" appears on any radiograph of a darker background, protection from scatter radiation is considered insufficient and the radiograph is considered unacceptable. A dark image of the "B" on a lighter background is not cause for rejection of the radiograph.

There is a common misconception by those not trained in industrial radiography that the letter "B" always appears on a radiograph. This is in fact not correct. Where there is no medium besides free air to cause backscatter, there will be insufficient radiation back to the film or imaging device to produce an image.

#### 9.8.9.6 Interpretation

Radiographic interpretation is the skill of extracting the maximum information from a radiographic image. This requires subjective judgment by the interpreter and is influenced by the interpreter's knowledge of:

- a) the characteristics of the radiation source and energy level(s) with respect to the material being examined;
- b) the characteristics of the recording media in response to the selected radiation source and the energy level(s);
- c) the processing of the recording media with respect to the image quality;
- d) the product form (object) being radiographed;
- e) the possible and most probable types of discontinuities that may occur in the test object;
- f) the possible variations of the discontinuities' images as a function of radiographic geometry, and other factors; and
- g) the acceptance criteria that are to be applied for accept/reject determination.

Because radiographic interpreters have varying levels of knowledge and experience, training becomes an important factor for improving the agreement levels between interpreters. In applications where quality of the final product is important for safety and/or reliability, more than one qualified interpreter should evaluate and pass judgment on the radiographs. Figure 35, Figure 36, Figure 37, Figure 38, Figure 39, Figure 40, Figure 41, Figure 42, Figure 43, Figure 44, Figure 45, and Figure 46 are radiographic weld images illustrating some typical welding discontinuities and defects.

### 9.8.10 Radiographic Examination Records

The information reported is to include, but is not be limited to the following:

- a) job/contract number/identification;
- b) location marker placement;
- c) number of radiographs (exposures);
- d) X-ray voltage or isotope type used;
- e) X-ray machine focal spot size or isotope physical source size;
- f) base material type and thickness, weld reinforcement thickness;
- g) source-to-object distance;
- h) distance from source side of object to film;
- i) film manufacturer and type/designation;
- j) number of film in each film holder/cassette;
- k) single or double-wall exposure;
- l) single or double-wall viewing;
- m) type of IQI (penetrameter) and the required hole/wire number designation;
- n) procedure and/or code references, examination results;
- o) date of examination, name and qualification of examiners.

Any drawings, component identification, or additional details need to be provided to the customer's representative, along with the examination report. A sample radiography report is provided in Annex E.

## 9.9 Ultrasonic Examination (UT)

### 9.9.1 General

UT is capable of detecting surface and subsurface discontinuities. A beam of sound in the ultrasonic frequency range (>20,000 cycles per second) travels a straight line through the metal and reflects from an interface. For weld inspection, this high frequency sound beam is introduced into the weld and heat affected zone on a predictable path, which, upon reflection back from an interruption in material continuity, produces a wave that is electronically amplified to produce images. These images are displayed such that they might give the inspector both the size and positional information of the discontinuity.



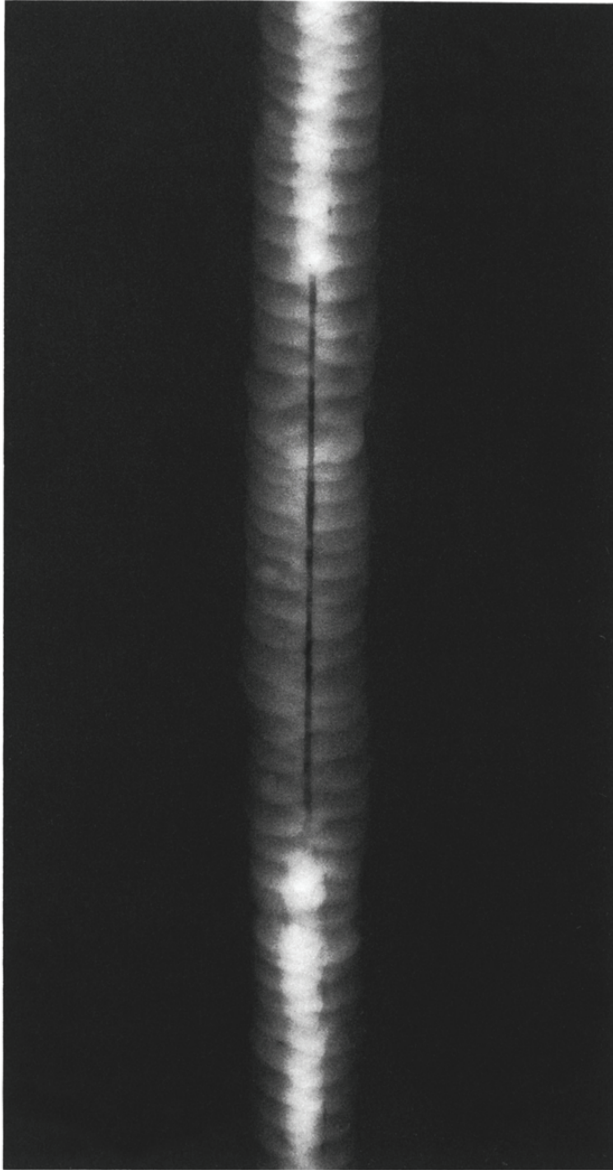
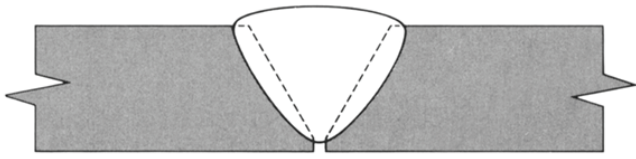

## Notes:

1. The edges of the pieces have not been welded together, usually at the bottom of single V-groove welds.
2. Radiographic Image: A darker density band, with straight parallel edges, in the center of the width of the weld image.
3. Welding Process: SMAW.

*Courtesy of Agfa NDT, Inc.*

**Figure 35—Incomplete or Lack of Penetration (LOP)**

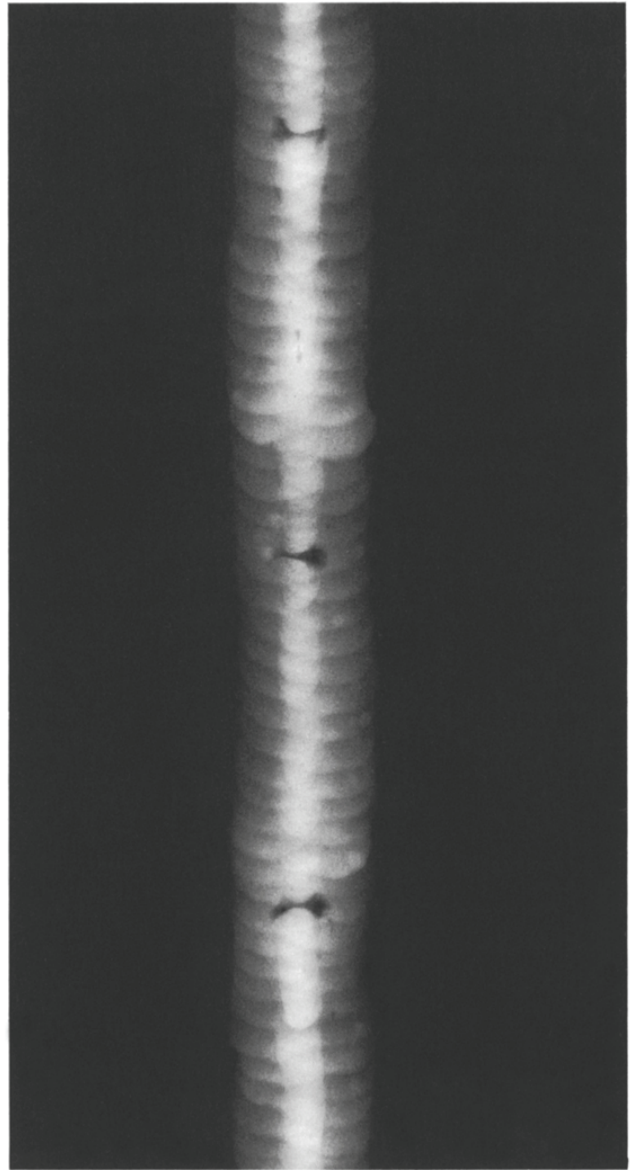
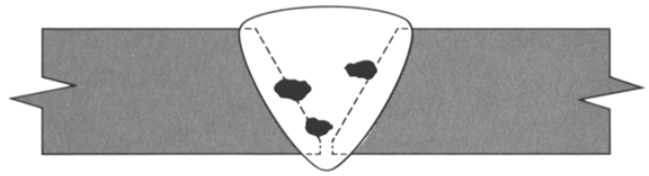

## Notes:

1. Usually caused by non-metallic impurities that solidify on the weld surface and are not removed between weld passes.
2. Radiographic Image: An irregularly shaped darker density spot usually slightly elongated and randomly spaced.
3. Welding Process: SMAW.

*Courtesy of Agfa NDT, Inc.*

**Figure 36—Interpass Slag Inclusions**

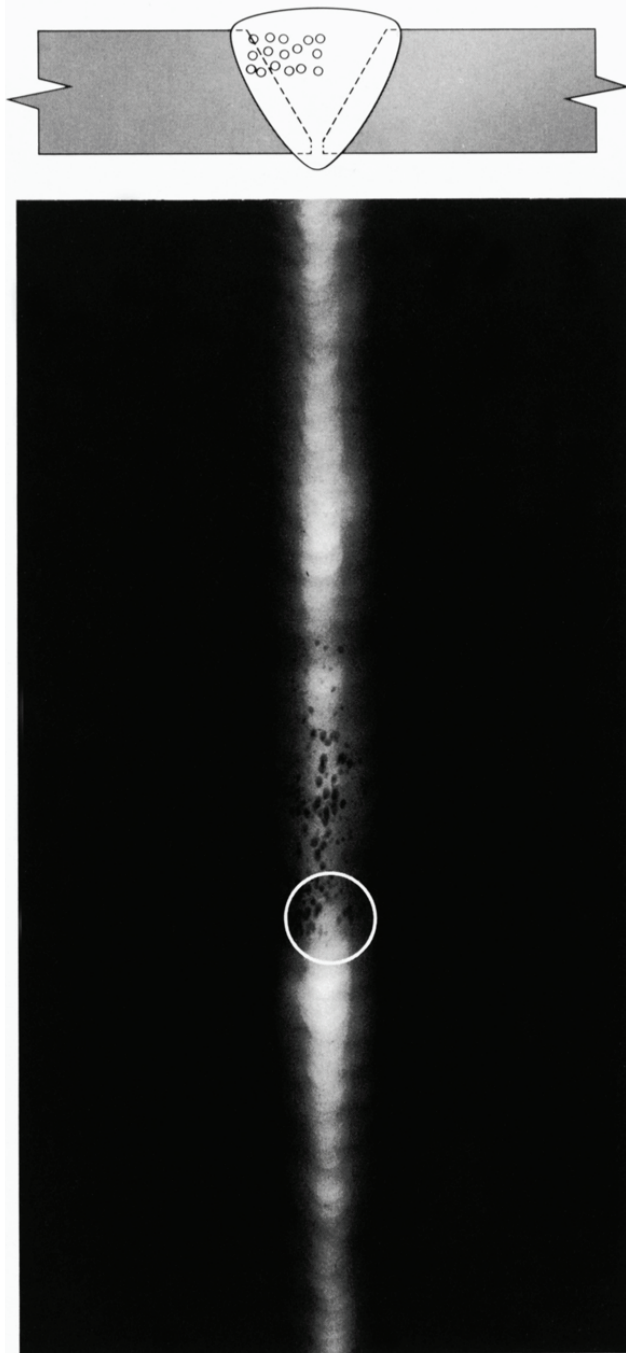

## Notes:

1. Rounded or slightly elongated voids grouped together.
2. Radiographic Image: Rounded or slightly elongated darker density spots in clusters randomly spaced.
3. Welding Process: SMAW.

*Courtesy of Agfa NDT, Inc.*

**Figure 37—Cluster Porosity**

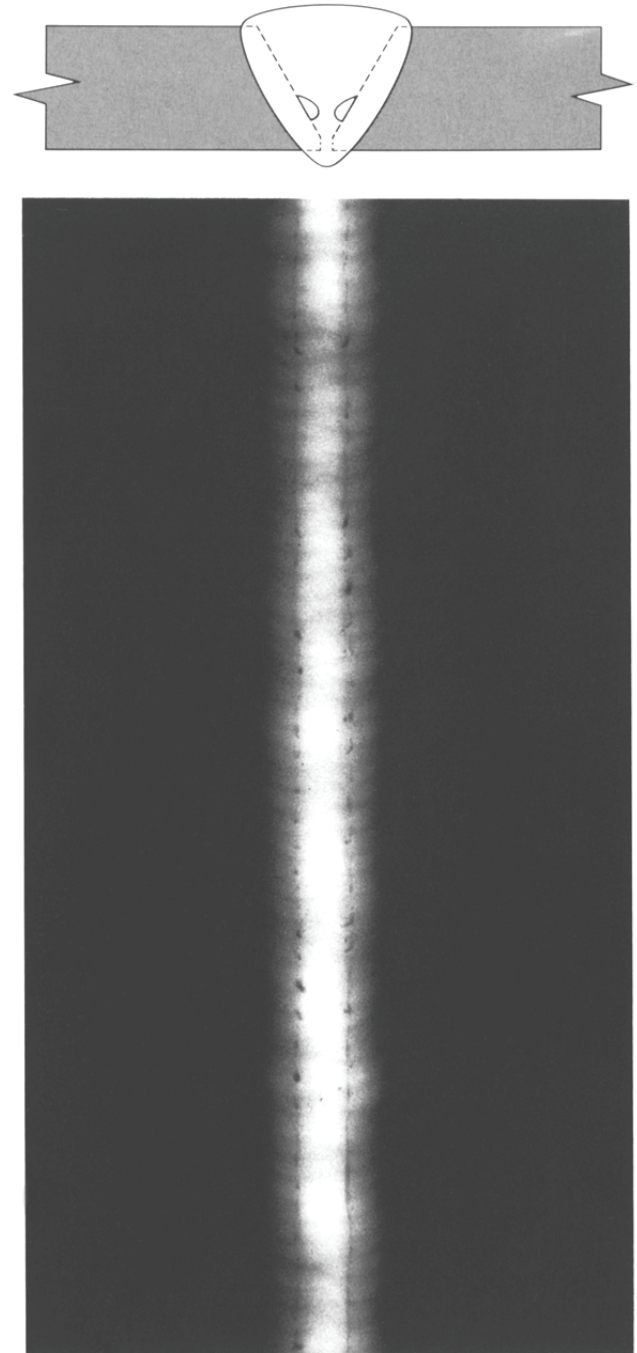

## Notes:

1. Elongated voids between the weld beads and the joint surfaces.
2. Radiographic Image: Elongated parallel, or single, darker density lines sometimes with darker density spots dispersed along the LOF lines which are very straight in the lengthwise direction and not winding like elongated slag lines.
3. Welding Process: GMAW.

*Courtesy of Agfa NDT, Inc.*

**Figure 38—Lack of Side Wall Fusion**



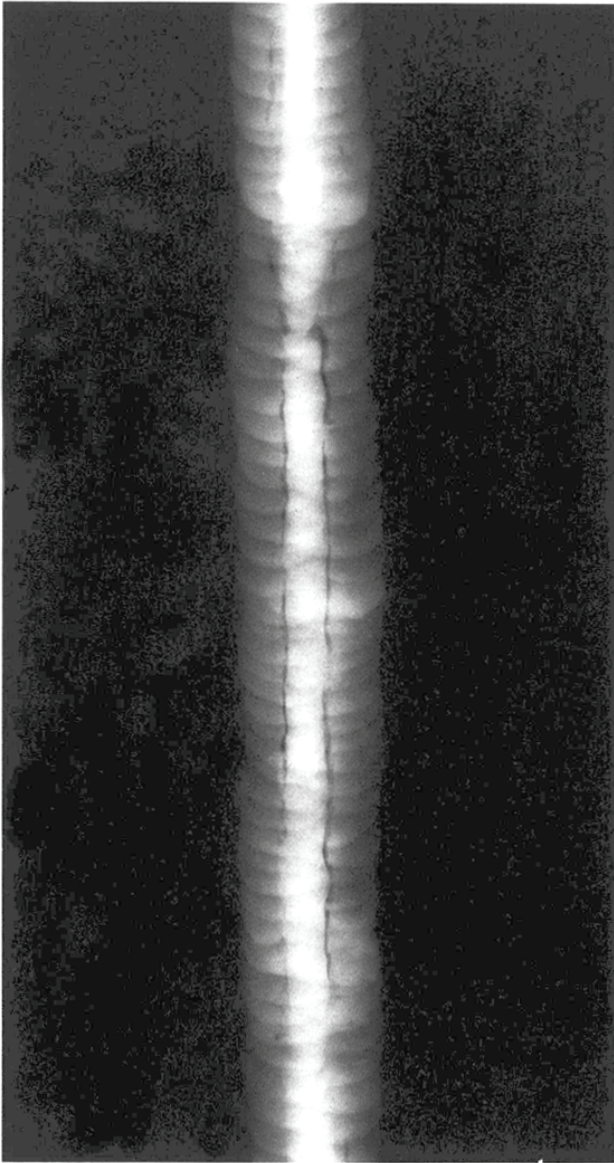
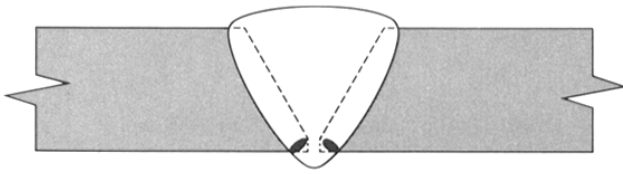

## Notes:

1. Impurities that solidify on the surface after welding and were not removed between passes.
2. Radiographic Image: Elongated, parallel, or single darker density lines, irregular in width and slightly winding in the lengthwise direction.
3. Welding Process: SMAW.

*Courtesy of Agfa NDT, Inc.*

**Figure 39—Elongated Slag (Wagon Tracks)**

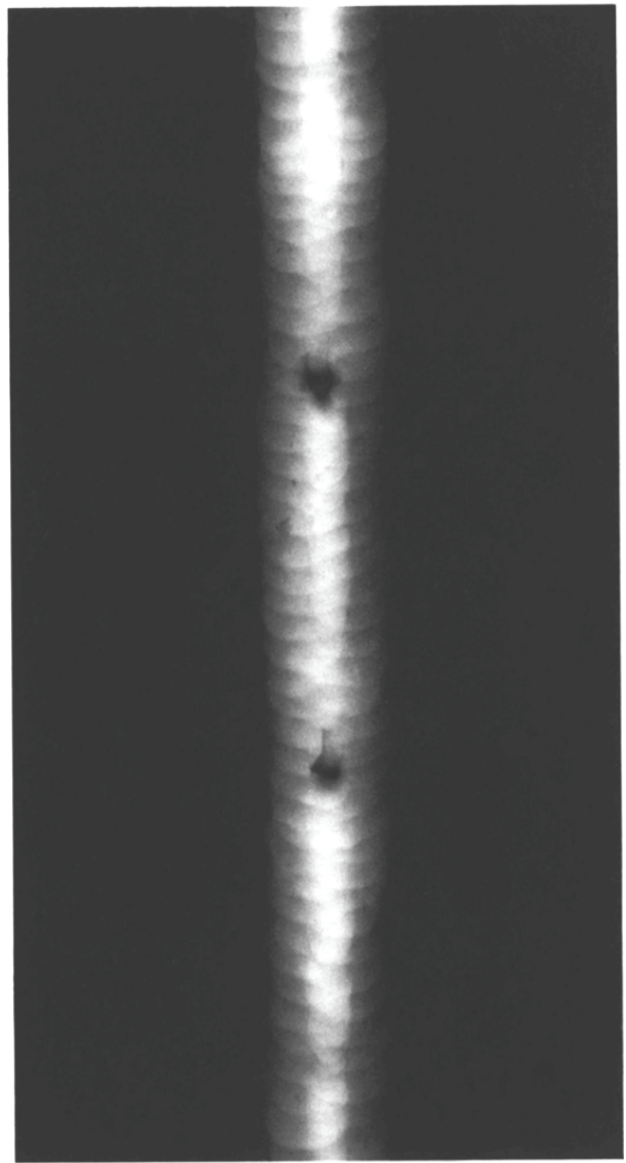
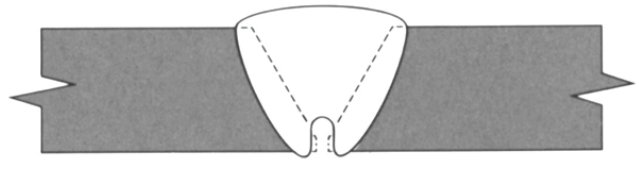

## Notes:

1. A severe depression or a crater-type hole at the bottom of the weld, but usually not elongated.
2. Radiographic Image: A localized darker density with fuzzy edges in the center of the width of the weld image. It may be wider than the width of the root pass image.
3. Welding Process: SMAW.

*Courtesy of Agfa NDT, Inc.*

**Figure 40—Burn-through**



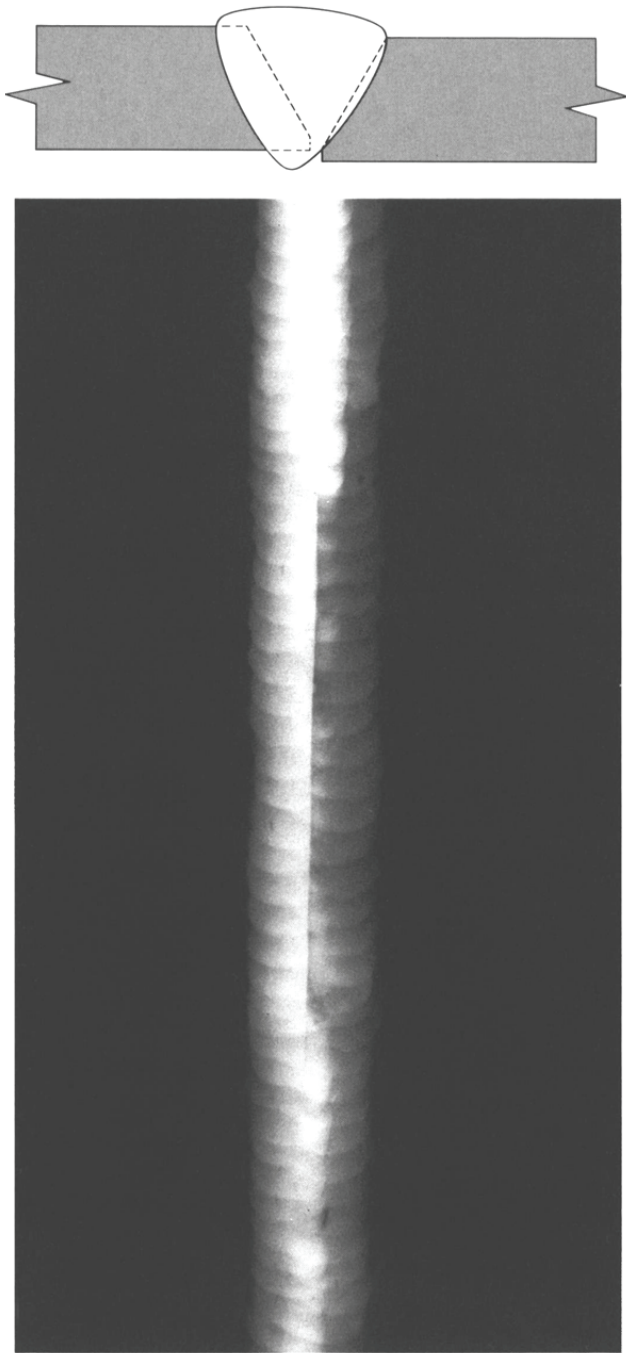

## Notes:

1. A misalignment of the pieces to be welded and insufficient filling of the bottom of the weld or "root area".
2. Radiographic Image: An abrupt density change across the width of the weld image with a straight longitudinal darker density line at the center of the width of the weld image along the edge of the density change.
3. Welding Process: SMAW.

*Courtesy of Agfa NDT, Inc.*

**Figure 41—Offset or Mismatch with Lack of Penetration (LOP)**

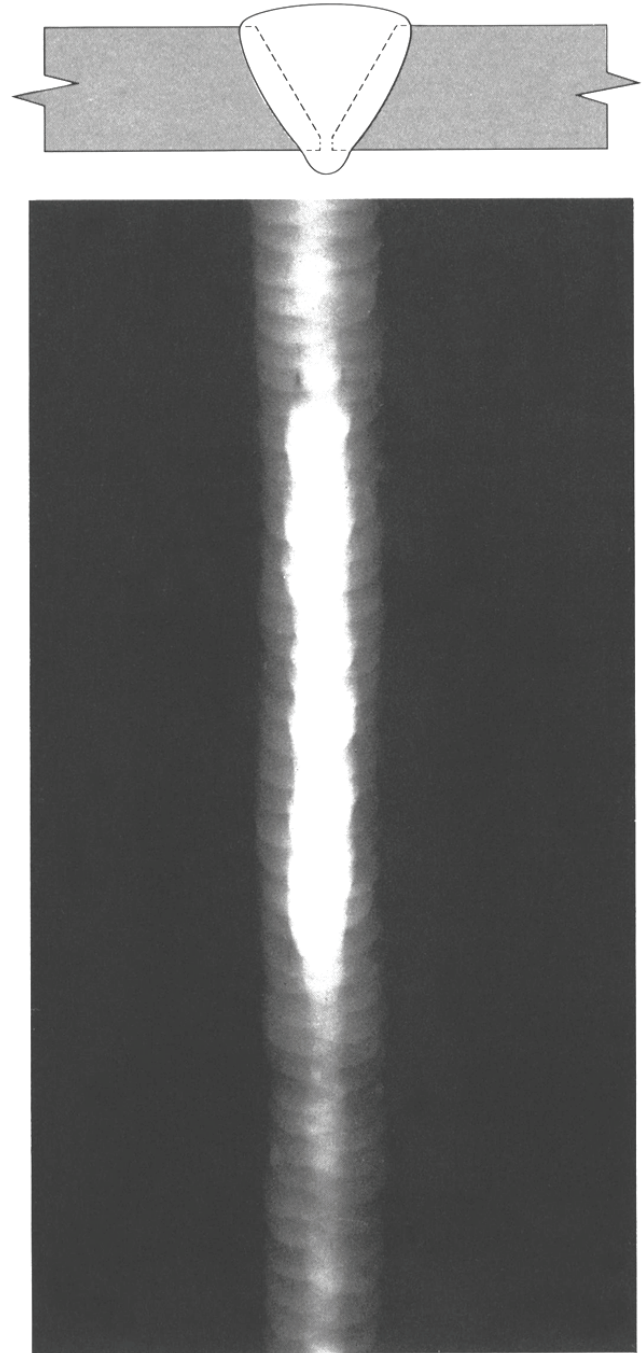

## Notes:

1. Extra metal at the bottom (root) of the weld.
2. Radiographic Image: A lighter density in the center of the width of the weld image, either extended along the weld or in isolated circular "drops".
3. Welding Process: SMAW.

*Courtesy of Agfa NDT, Inc.*

**Figure 42—Excessive Penetration (Icicles, Drop-through)**

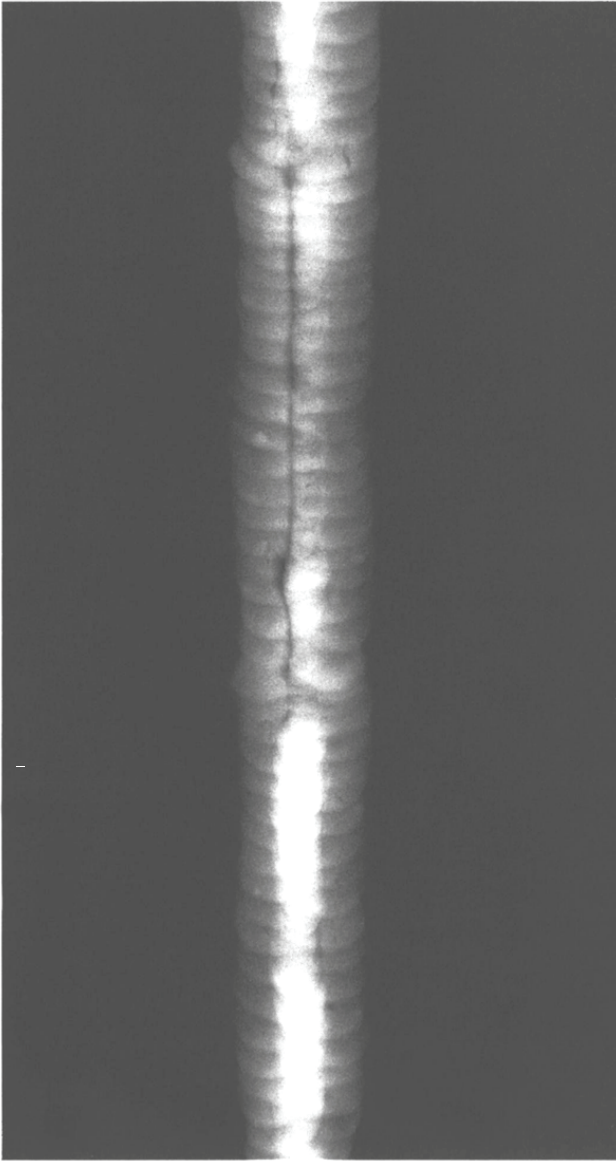
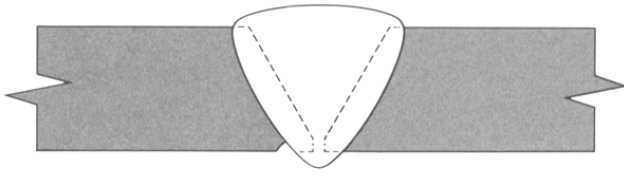

## Notes:

1. A gouging out of the parent metal, alongside the edge of the bottom or internal surface of the weld.
2. Radiographic Image: An irregular darker density near the center of the width of the weld image along the edge of the root pass image.
3. Welding Process: SMAW.

*Courtesy of Agfa NDT, Inc.*

**Figure 43—Internal (Root) Undercut**

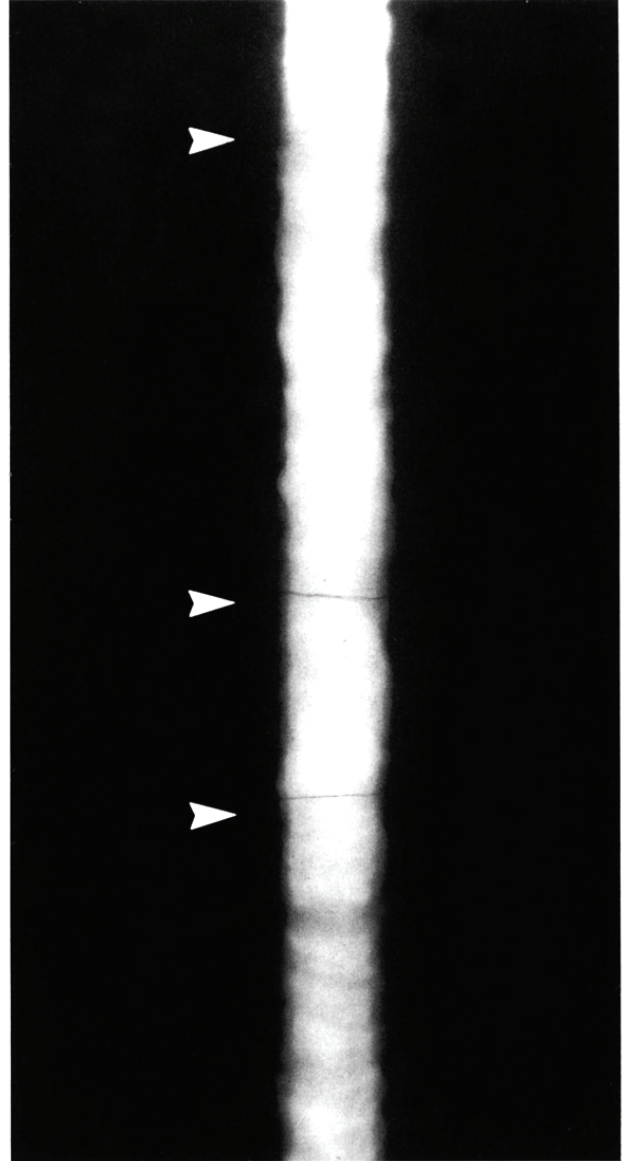
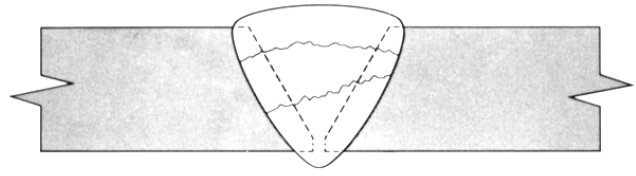

## Notes:

1. A fracture in the weld metal running across the weld.
2. Radiographic Image: feathery, twisted line of darker density running across the width of the weld image.
3. Welding Process: GIAW.

*Courtesy of Agfa NDT, Inc.*

**Figure 44—Transverse Crack**

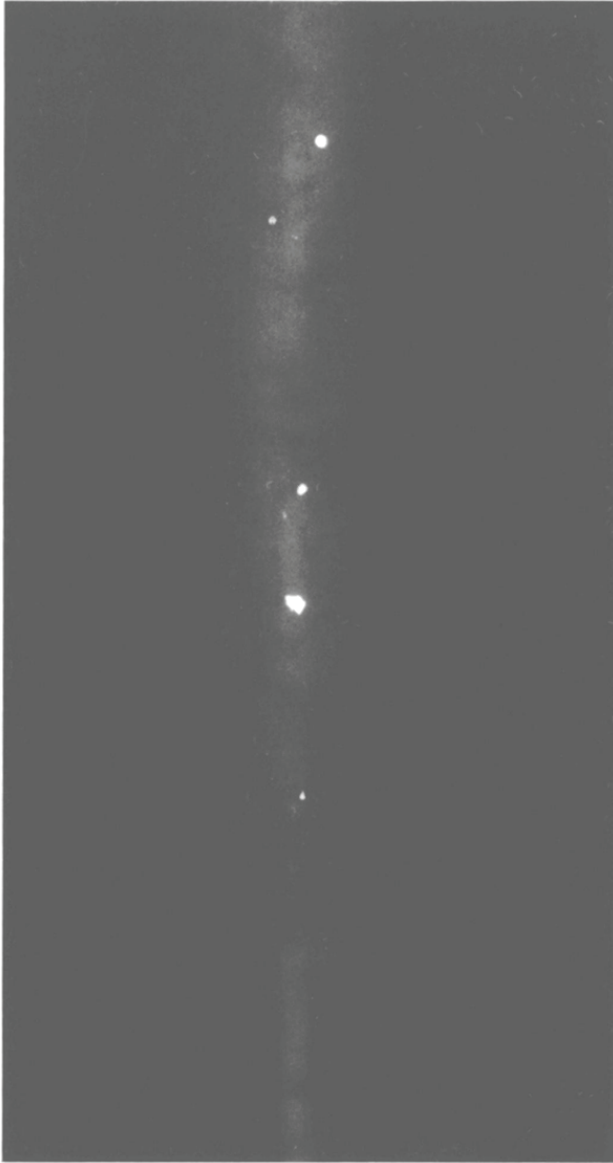
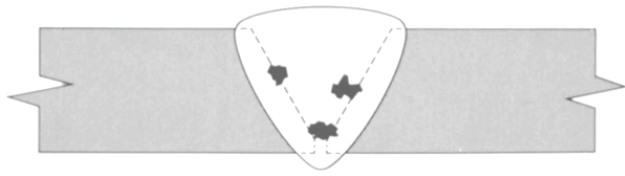

## Notes:

1. Random bits of tungsten fused into but not melted into the weld metal.
2. Radiographic Image: Irregular shaped lower density spots randomly located in the weld image.
3. Welding Process: GIAW.

*Courtesy of Agfa NDT, Inc.*

**Figure 45—Tungsten Inclusions**

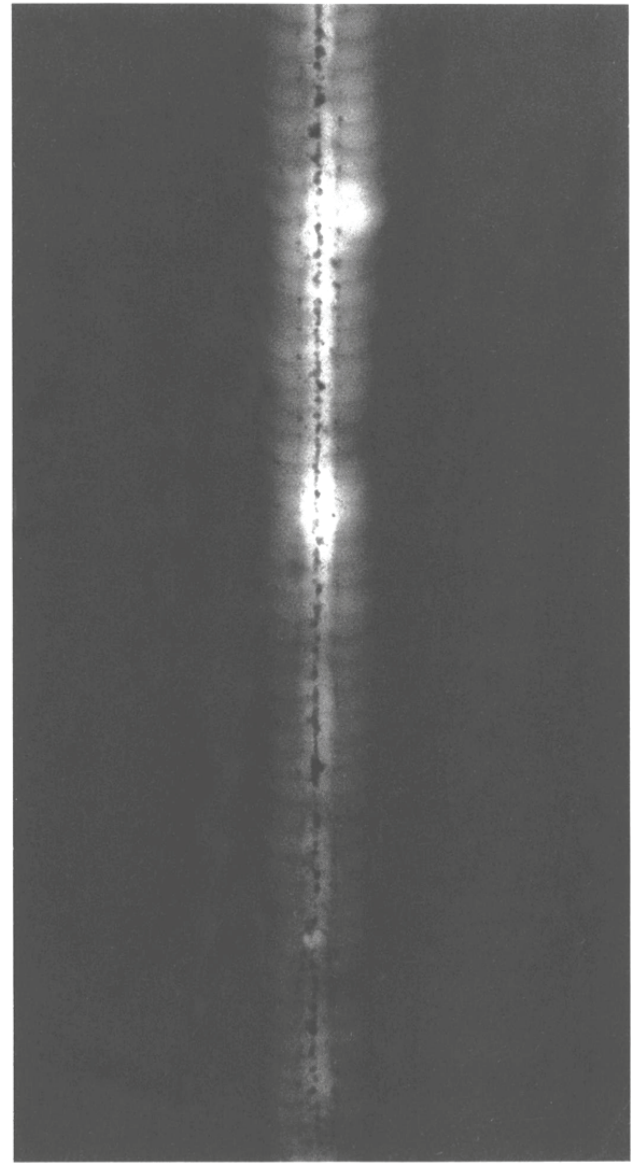
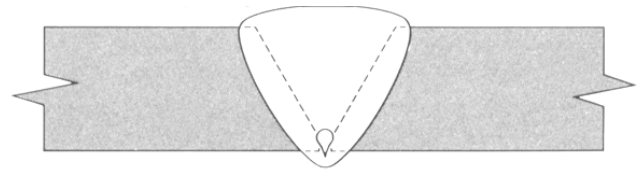

## Notes:

1. Rounded and elongated voids in the bottom of the weld aligned along the weld centerline.
2. Radiographic Image: Rounded and elongated darker density spots, that may be connected, in a straight line in the center of the width of the weld image.
3. Welding Process: GMAW.

*Courtesy of Agfa NDT, Inc.*

**Figure 46—Root Pass Aligned Porosity**



Straight beam techniques are used for thickness evaluation or to check for laminations, and/or other conditions which may prevent angle beams from interrogating the weld. Straight beam (or zero degree) transducers, direct a sound beam from an accessible surface of the test piece to a boundary or interface that is parallel or near parallel to the contacted surface. The time it takes for the sound to make a round trip through the piece is displayed on the ultrasonic instruments time base. There are a number of different ways that straight-beam ultrasonic information can be displayed as shown in Figure 47, Figure 48, and Figure 49, reprinted courtesy of GE Inspection. These displays represent an accurate thickness of the test piece.

Shear wave or angle beam techniques are employed for identification of discontinuities in welds. The sound beam enters the area of the weld at an angle. If the sound reflects from a discontinuity, a portion of the sound beam returns to the receiver where it is displayed on the ultrasonic instrument. These images can be displayed in a number of ways to aid in evaluation. From this display, information such as the size, location and type of discontinuity can be determined.

## 9.9.2 Types of Ultrasonic Displays

### 9.9.2.1 A-Scan Display

The A-scan, as shown in Figure 47, is the most common display type. It shows the response along the path of the sound beam for a given position of the probe. It shows the amplitude of the signal coming from the discontinuity as a function of time. The 'x' axis (right) represents the time of flight and indicates the depth of a discontinuity or back wall (thickness). The 'y' axis shows the amplitude of reflected signals (echoes) and can be used to estimate the size of a discontinuity compared to a known reference reflector.

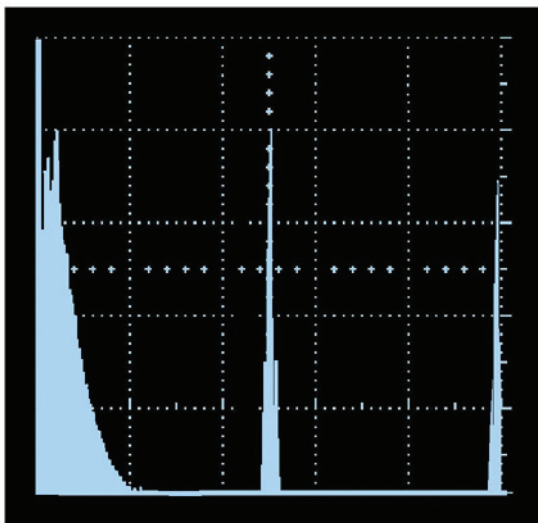
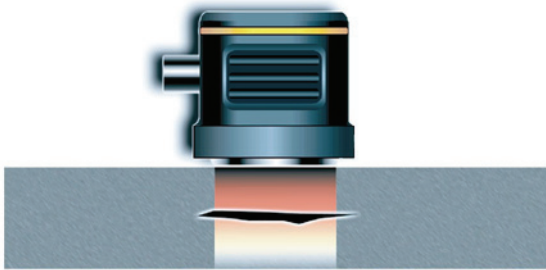

*Courtesy of GE Inspection*

**Figure 47—A-scan**

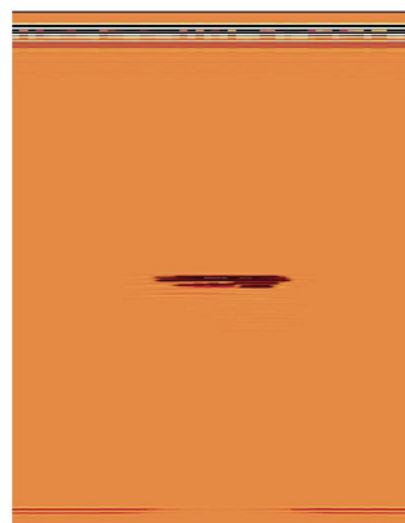
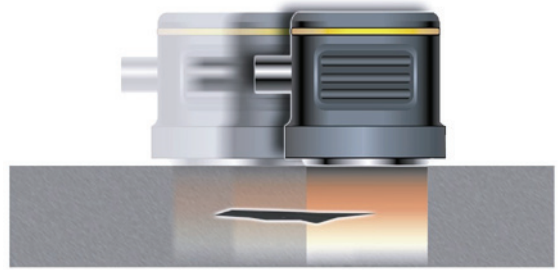

*Courtesy of GE Inspection*

**Figure 48—B-scan**

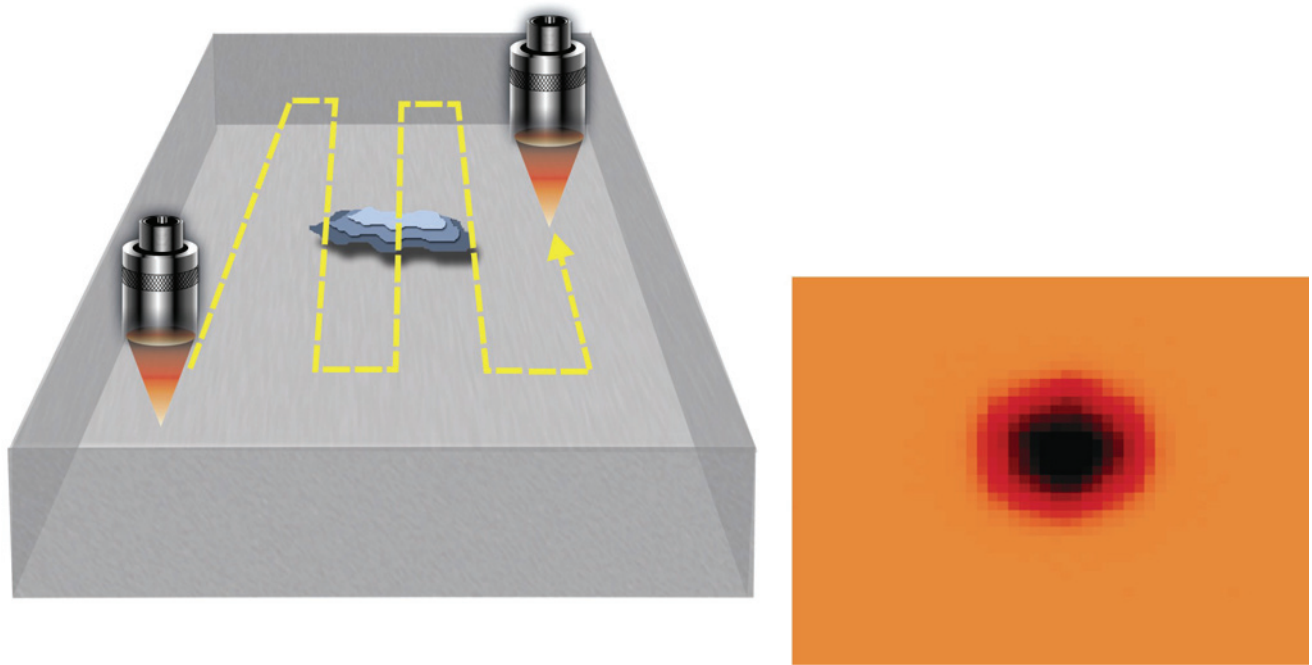

*Courtesy of GE Inspection*

**Figure 49—C-scan**

### 9.9.2.2 B-Scan Display

The B-scan display (see Figure 48) shows a cross sectional view of the object under test by scanning the probe along one axis. The horizontal axis (left) relates to the position of the probe as it moves along the surface of the object and provides information as to the lateral location of the discontinuity. Echo amplitude is usually indicated by the color or gray scale intensity of echo indications.

### 9.9.2.3 C-Scan Display

The C-scan display (see Figure 49) shows a plan view of the test object. The image is produced by mechanically or electronically scanning in an x-y plane. The 'x' and 'y' axis form a coordinate system that indicates probe/discontinuity position. Color or gray scale intensity can be used to represent depth of discontinuity or echo amplitude.

### 9.9.2.4 D-Scan Display

The D-scan display (see Figure 50) shows a through-thickness view showing a cross-section of the test object perpendicular to the scanning surface and perpendicular to the projection of the beam axis on the scanning surface. The D-scan display is exactly like a B-scan display except that the view is oriented perpendicular to B-scan view in the plane of the plate. The D-scan allows quick discrimination of indications along a weld by presenting their position in depth from the scanning surface. An example of the relationship between all four common ultrasonic displays is shown in Figure 50.

### 9.9.2.5 Phased Array S-Scan Display

The S-Scan or sector display (see Figure 51) shows two dimensional imaging of ultrasonic reflectors by plotting information from a multitude of angles simultaneously. The image is a cross sectional view of the area where the ultrasound passes through. Location and size information can be measured for any reflectors that are in the Sectorial scan.

Phased Array ultrasonics accomplishes this by using a transducer that contains multiple elements, 8 to 128 commonly, that are excited at intervals to create constructive interference in the wave front of ultrasonic energy. This

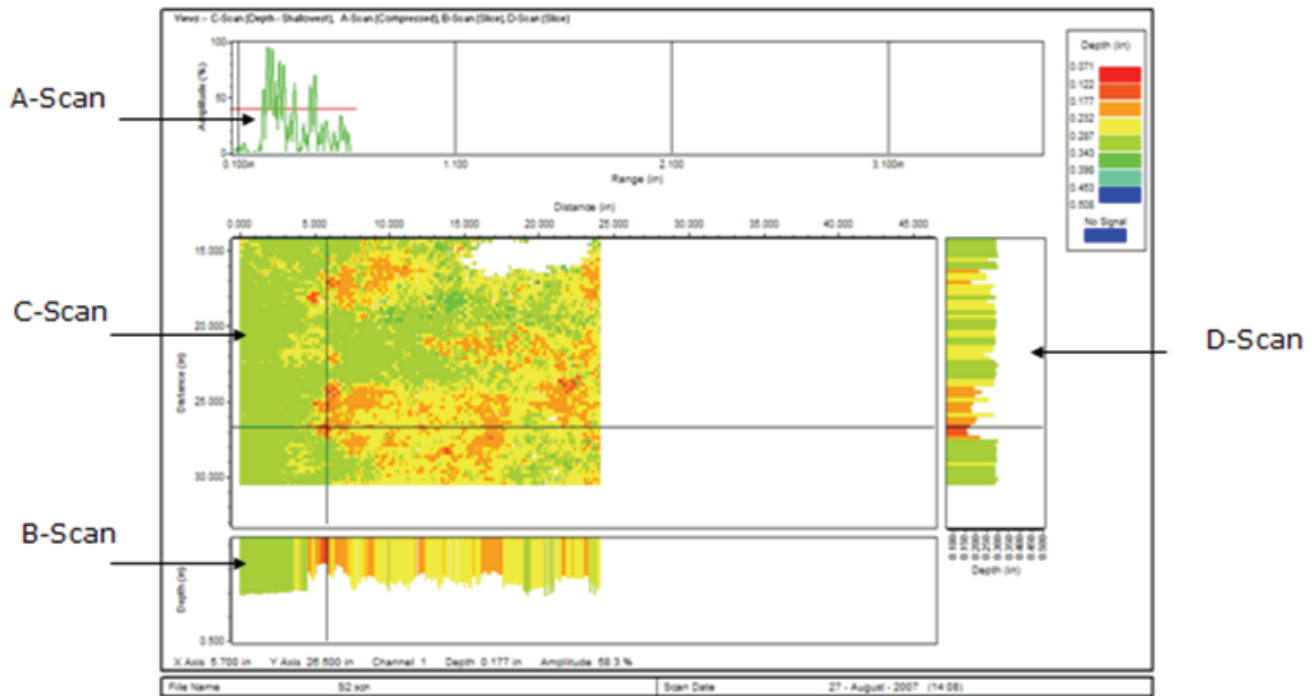

Figure 50—D-scan

constructive interference is controlled by the amount of time delay in element excitation and can steer the sound through a range of angles. This array of beam angles is then plotted to create the sector scan. The ultrasonic energy provides responses in a pulse-echo fashion as with conventional straight beam and angle beam techniques.

#### 9.9.2.6 Time of Flight Diffraction (TOFD) B-scan and D-scan displays (see Figure 52 and Figure 53)

The B-scan and D-scan displays are a different format than the B & D scan displays acquired in any other ultrasonic technique utilizing information provided in a pulse echo fashion. TOFD B & D scan images provide defect sizing information for through wall extent by using diffracted signals rather than pulse echo signals. The TOFD B & D scan displays are created by stacking A-scan displays at a preset interval or collection step and viewing the data in a grayscale image where 100 % amplitude of the sine wave in either the positive or negative direction are plotted as all black or all white with gray images of signals less than 100 % amplitude.

TOFD passes sound energy through a weld area by utilizing a transmitting transducer on one side of the weld and a receiving transducer on the other (see Figure 54). Any changes in the material, such as discontinuities, are vibrated by the induced ultrasonic energy. This vibration of discontinuities produces diffracted signals from the discontinuity that are then received by the receiving transducer.

The set of TOFD probes can be manipulated along a weld or across a weld to create scans. Standard TOFD weld inspection is accomplished by moving TOFD probes along the weld, with one transducer on each side of the weld, where the ultrasonic energy is perpendicular to the weld. This is a TOFD D-scan or non-parallel scan. The TOFD probes can also be manipulated across an area parallel to the sound path to evaluate an indication from a position 90 degrees from the perpendicular imaging. This is a TOFD B-scan or parallel scan. This can only be accomplished if the weld cap has been removed for the purpose of weld inspection and is most often used to provide more accurate defect location information once defects have been located with the TOFD D-scan.

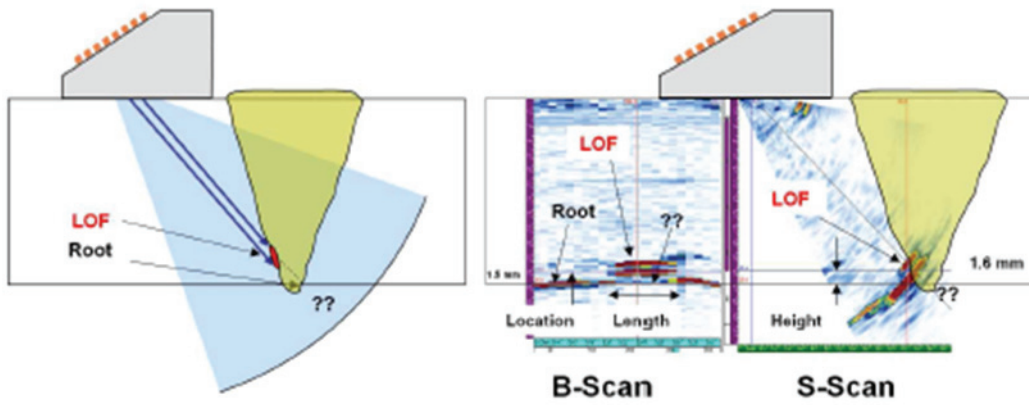
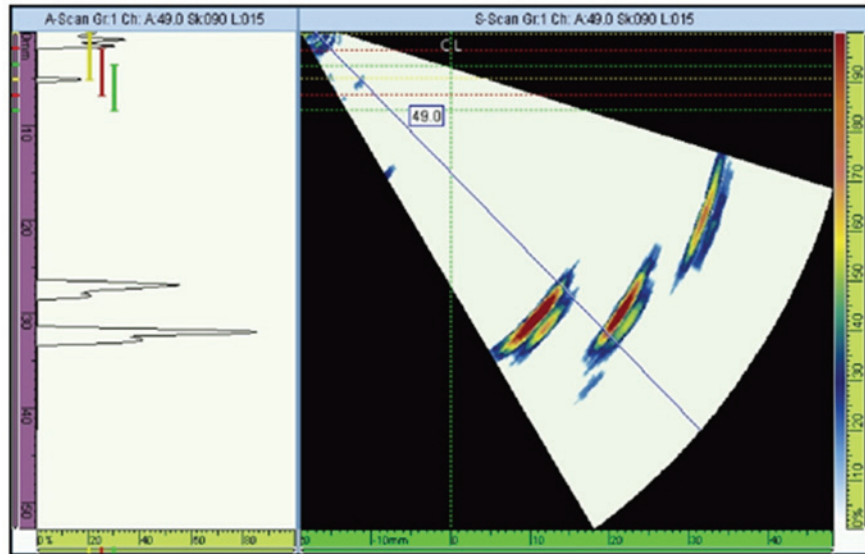
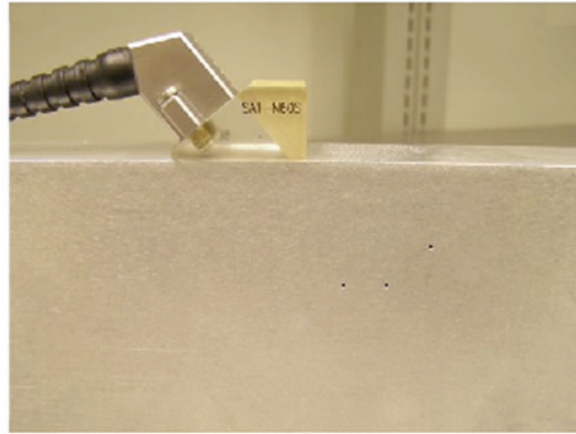

Figure 51—S-scan



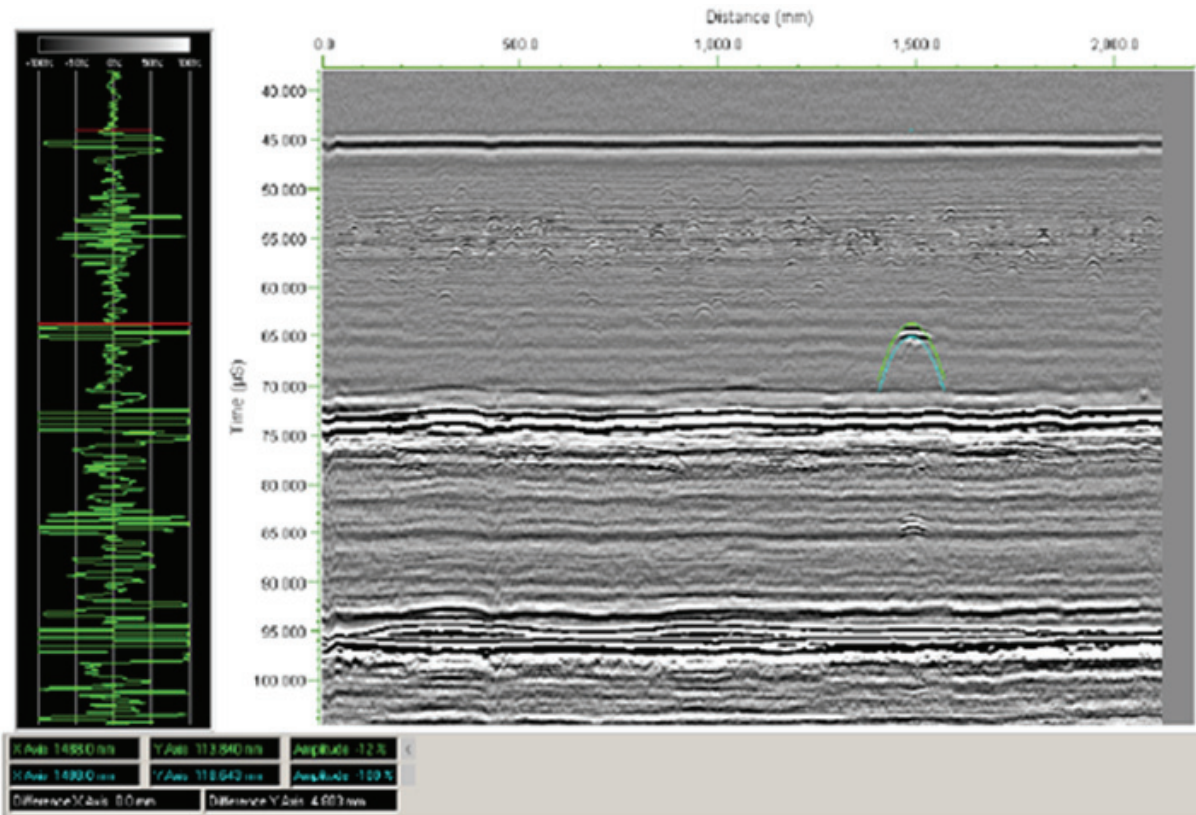

Figure 52—TOFD D-scan Display

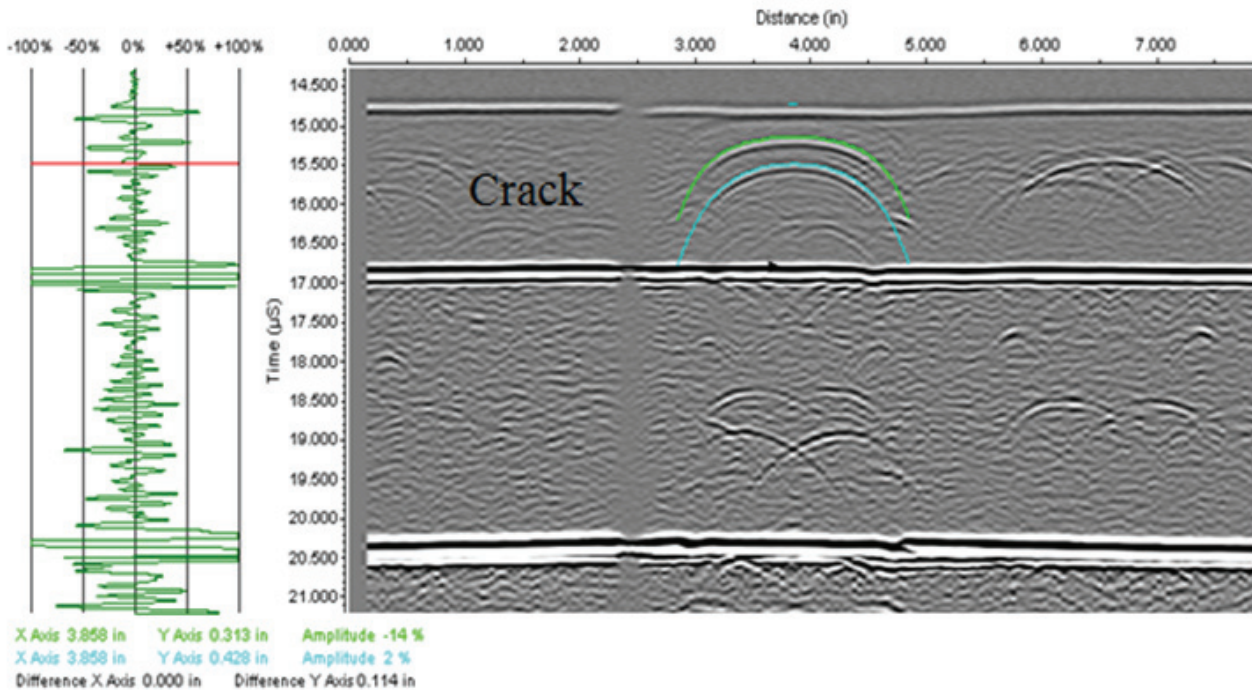
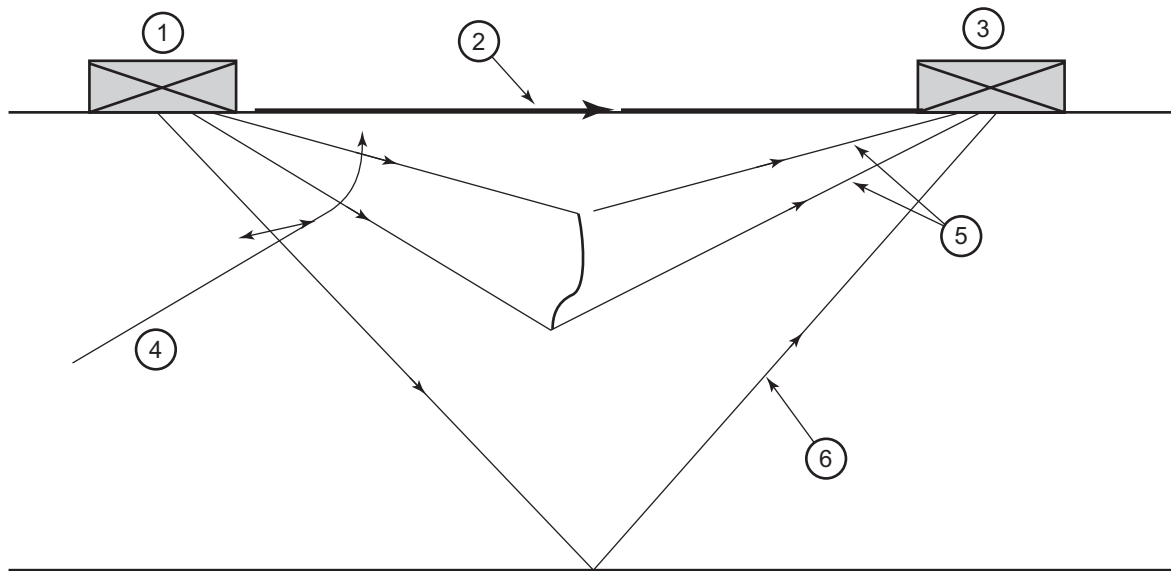

Figure 53—TOFD B-scan



**Key**

- 1 transmitter
- 2 lateral wave
- 3 receiver
- 4 longitudinal wave and shear wave beam spread
- 5 diffracted energy from flaw tips
- 6 back wall echo

**Figure 54—TOFD Transducer Arrangement and Ultrasonic Energy Beam Propagation**

### 9.9.2.7 Requirements for Ultrasonic Inspection

ASME Section V, Article 4, lists the general requirements for ultrasonic examination. Codes and specifications may list compliance with these requirements as mandatory. ASME B31.3 and ASME Section VIII, Division 1, requires ultrasonic examination be performed in accordance with Article 4. Article 4 requires a written procedure be followed, and some of the requirements to be included in the procedure are:

- a) weld, base metal types, and configurations to be examined;
- b) technique (straight or angle beam);
- c) couplant type;
- d) ultrasonic instrument type;
- e) instrument linearity requirements;
- f) description of calibration;
- g) calibration block material and design;
- h) inspection surface preparation;
- i) scanning requirements (parallel and perpendicular to the weld);
- j) scanning techniques (manual or automated);
- k) evaluation requirements;

- l) data to be recorded;
- m) reporting of indications in terms of the acceptance standards of the referencing code;
- n) post examination cleaning.

### **9.9.3 Ultrasonic Examination System Calibration**

#### **9.9.3.1 General**

Ultrasonic examination system calibration is the process of adjusting the controls of the ultrasonic instrument such that the UT display of the sound path is linear. Calibration is to ensure that there is sufficient sensitivity to detect discontinuity of the size and type expected in the product form and process.

The inspection system includes the examiner, the ultrasonic instrument, cabling, the search unit, including wedges or shoes, couplant, and a reference standard. The search unit transducer should be of a size, frequency, and angle that is capable of detecting the smallest rejectable defect expected to be in the part being examined. The ultrasonic instrument is required to meet or exceed the requirements of ASME Section V, Article 5, Paragraph T-530, and should provide the functionality to produce the required display of both the calibration reflectors and any discontinuities located during the examination.

The reference standard (calibration block) should be of the same nominal diameter and thickness, composition and heat treatment condition as the product that is being examined. It should also have the same surface condition as the part being examined. The reference standard should be of an acceptable size and have known reflectors of a specified size and location. These reflectors should be acceptable to the referencing code. ASME Section V, Article 4, Figure T-434.2.1 and Figure T-434.3 details the requirements for basic calibration block construction.

Calibration system checks should be performed prior to and at the completion of an examination. In addition, a system check is required with any change in the search unit, cabling, and examiner. The temperature of the calibration standard should be within 25 °F (14 °C) of the part to be examined. If the temperature falls out of that range, the reference standard is brought to within 25 °F (14 °C), and a calibration check should be performed. For high temperature work, special high temperature transducers and couplants are usually necessary. Consideration should be given to the fact that temperature variations within the wedge or delay line can cause beam angle changes and/or alter the delay on the time base. System checks are typically performed at a minimum of every four hours during the process of examination but can be done more often at the examiners discretion after any instance of suspected system irregularity.

If during a system calibration check, it is determined that the ultrasonic equipment is not functioning properly, all areas tested since the last successful calibration should be reexamined.

#### **9.9.3.2 Echo Evaluation with DAC**

The distance amplitude correction (DAC) curve allows a simple echo evaluation of unknown reflectors by comparison of the echo height with respect to the DAC (%DAC).

Because of attenuation and beam divergence in all materials, the echo amplitude from a given size reflector decreases as the distance from the probe increases. To set up a DAC curve, the maximum response from a specified reference reflector (e.g. flat bottom or side drilled hole) is recorded at different depths over the required test range. The calibration block with reference reflectors should be of the same material as the part under test. The curve is plotted through the peak points of the echo signals from the reflectors as shown in Figure 55. The curve represents the signal amplitude loss based upon distance, from the same size reference reflector using a given probe. The gain setting used to establish the DAC during the initial calibration is referred to as the primary reference level sensitivity. Evaluation is performed at this sensitivity level.

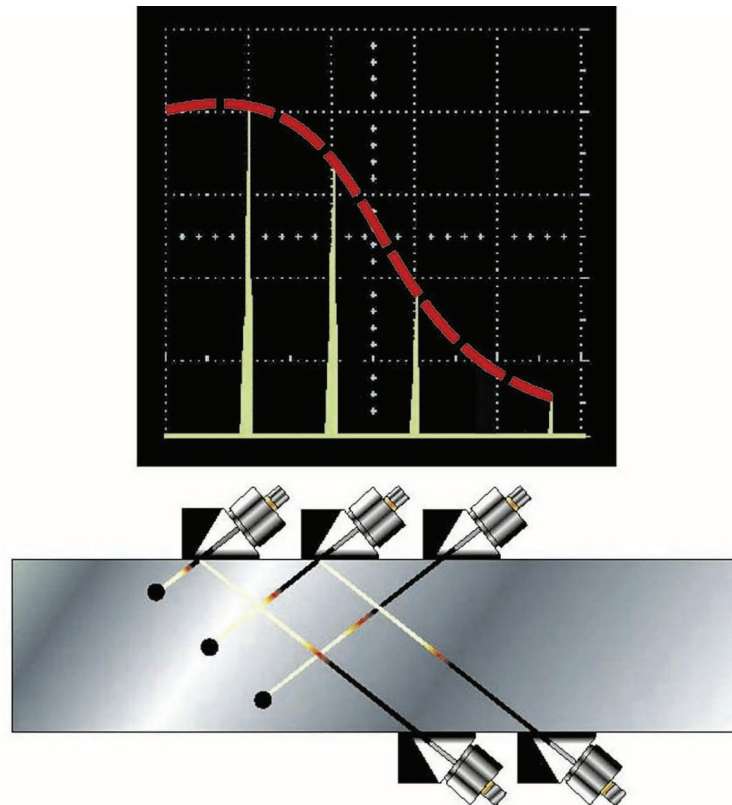

**Figure 55—DAC Curve for a Specified Reference Reflector**

Unknown reflectors (flaws) are evaluated by comparing their echo amplitude against the height of the DAC curve (i.e. 50 % DAC, 80 % DAC, etc.) at the sound path distance of the unknown reflector (see Figure 56). Material characteristics and beam divergence are automatically compensated for because the reference block and the test object are made of the same material, have the same heat treatment and surface condition.

#### 9.9.4 Surface Preparation

Prior to UT examination, all scan surfaces should be free from weld spatter, surface irregularities and foreign matter that might interfere with the examination. The weld surface should be prepared such that it permits a meaningful examination.

#### 9.9.5 Examination Coverage

The volume of the weld, HAZ, and a portion of the adjacent base material on both sides of the weld should be examined by moving the search unit over the examination surface in order to scan the entire examination volume. Each pass of the transducer should overlap the previous pass by 10 % of the transducer element dimension. The rate of search unit movement should not exceed 6 in. (152 mm) per second unless the calibration was verified at an increased speed. In many cases, the search unit is oscillated from side to side to increase the chances of detecting fine cracks that are oriented other than perpendicular to the sound beam.

#### 9.9.6 Straight Beam Examination

A straight beam examination should be performed adjacent to the weld to detect reflectors that would interfere with the angle beam from examining the weld such as a lamination in the base material. All areas having this type of reflector should be recorded.

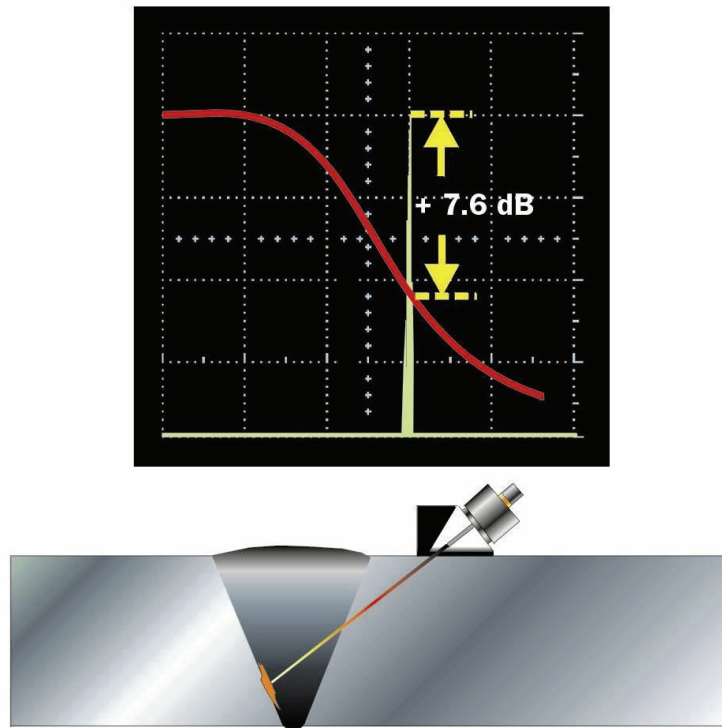

**Figure 56—DAC Curve for an Unknown Reflector**

## 9.9.7 Angle Beam Examination

### 9.9.7.1 General

Typically, there are two different angle beam examinations performed on a weld. A scan for reflectors that are oriented parallel to the weld, and a scan for reflectors that are oriented transverse to the weld. In both cases, the scanning should be performed at a gain setting at least two times the reference level sensitivity established during calibration. Evaluation of indications however, should be performed at the primary reference level sensitivity. In both cases, the search unit should be manipulated such that the ultrasonic energy passes through the required volume of the weld and HAZ.

During examination for reflectors that are oriented parallel to the weld, the sound beam is directed at approximate right angles to the weld, preferably from both sides of the weld. For reflectors that are oriented transverse to the weld, the sound beam is directed parallel to the weld and a scan is performed in one direction around the weld, then the search unit is turned 180 degrees and another scan is performed until the ultrasonic energy passes through the required volume of weld and HAZ in two directions.

To inspect for transverse flaws, the angle-beam transducers should be rotated 90 degrees, or additional transverse flaw inspection using other techniques may be performed to supplement automated ultrasonic weld inspection techniques.

### 9.9.7.2 Supplemental Shear Wave Examination

When inspecting a weld with TOFD, the presence of the lateral wave and back-wall indication signals, may obscure detection of flaws present in these zones. ASME BPVC Section V requires that the weld's near and far surfaces (i.e. both top and bottom surfaces) be examined by angle beam with the angles chosen that are closest to being perpendicular to the fusion lines. This examination may be performed manually or mechanized; if mechanized, the data should be collected in conjunction with the TOFD examination.

## 9.9.8 Automated Ultrasonic Testing (AUT)

Volumetric Inspection of welds may be performed using one of the four automated ultrasonic weld inspection techniques.

- 1) Pulse Echo Raster Scanning: This technique inspects with zero degree compression and two angle beam transducers interrogating the weld from either side simultaneously. The compression transducers examine for corrosion or laminar defects in the base metal and the angle beam transducers scan the volume of the weld metal.
- 2) Pulse Echo Zoned Inspection: The zoned inspection is a Line Scan technique. The technique uses an array of transducers on either side of the weld with the transducer angles and transit time gates set to ensure that the complete volume of the weld is inspected.
- 3) Time of Flight Diffraction (TOFD): This is a line scan technique used in the pitch-catch mode. The multi-mode transducers are used to obtain the maximum volume inspection of the weld region. More than one set of transducers may be required for a complete volumetric inspection.
- 4) Phased Array (PA) Inspection: This technique utilizes an array of transducer elements to produce steering of the ultrasonic beam axis or focusing of the ultrasonic beam over a specified range. This allows the user the ability to inspect certain portions or zones of the component being tested using many different beam angles.

## 9.9.9 Discontinuity Evaluation and Sizing

### 9.9.9.1 General

UT procedures should include the requirements for the evaluation of discontinuities. Typically, any imperfection that causes an indication in excess of a certain percentage of DAC curve should be investigated in terms of the acceptance standards. The procedure should detail the sizing technique to be used to plot the through thickness dimension and length.

One commonly used sizing technique is called the “intensity drop” or “6 dB drop” technique. This sizing technique uses the beam spread of the transducer to quickly estimate the axial length of the reflector. Using this technique, the transducer is positioned on the part such that the amplitude from the reflector is maximized. This point is marked with a grease pencil. The UT instrument is adjusted to set the signal to 80 % full screen height (FSH). The transducer is then moved laterally until the echo has dropped to 40 % FSH (6dB). This position is also marked. The transducer is then moved laterally in the other direction, past the maximum amplitude point, until the echo response again reaches 40 % FSH. This point is marked with the grease pencil. The two outside marks produce the approximate axial size of the flaw.

Other sizing techniques should be used to get a more precise measurement of the length and through wall dimension of the flaw. With advances in technologies a number of other through-thickness sizing techniques are described in 9.9.9.2, 9.9.9.3, 9.9.9.4, and 9.9.9.5.

### 9.9.9.2 The ID Creeping Wave Method

The ID Creeping wave method uses the effects of multiple sound modes, such as longitudinal waves and shear waves to qualitatively size flaws. The method is used for the global location of flaws in the bottom  $\frac{1}{3}$ , middle  $\frac{1}{3}$ , and top  $\frac{1}{3}$  regions. Three specific waves are presented with the ID Creeping wave method.

- a) High angle refracted longitudinal wave of approximately 70 degrees.
- b) Direct 30 degree shear wave which mode converts to a 70 degree refracted longitudinal wave.

- c) Indirect shear or “head” wave which mode converts at the inside diameter from a shear wave to a longitudinal wave, and moves along the surface.

### 9.9.9.3 The Tip Diffraction Method

Tip diffraction methods are very effective for sizing flaws which are open to the inside or outside diameter surface. For ID connected flaws, the half “V” path or one and one half “V” path technique is used. For OD connected flaws, two techniques are available; the time-of-flight tip diffraction technique and the time measurement technique of the tip diffracted signal and the base signal.

### 9.9.9.4 The High Angle Longitudinal Method

The high angle refracted longitudinal wave method is very effective for very deep flaws. Dual element, focused, 60, 70, and OD creeping wave are used to examine the outer one half thickness of the component material. Probe designs vary with the manufacturer. Depth of penetration is dependent upon angle of refraction, frequency, and focused depth. Many of these transducers are used not only for sizing, but also for detection and confirmation of flaws detected during the primary detection examination. For coarse grain materials, these probes work well where shear wave probes are ineffective.

### 9.9.9.5 The Bimodal Method

The bimodal method is a dual element tandem probe with the transducers crystals located one in front of the other. The probe also generates an ID creeping wave. The wave physics are essentially the same. The pseudo-focusing effect of the dual element crystals is very effective for ID connected flaws in the mid-wall region, 30 % to 60 % through wall depth. A low angle shear wave (indirect) mode converts at the ID to produce an ID creeping wave, which detects the base of the flaw. A further low angle shear wave mode converts at the ID to a longitudinal wave, which reflects a longitudinal wave from the flaw face. A high angle refracted longitudinal wave detects the upper extremity of the flaw (70 degrees). The bimodal method can be used to confirm the depth of shallow to deep ID connected flaws. However, very shallow flaws of less than 10 % to 20 % tend to be slightly oversized, and very deep flaws tend to be slightly undersized.

Significant training and experience is required to effectively utilize some of the more advanced UT detection and sizing techniques.

### 9.9.9.6 The Phased Array Method

The phased array method utilizes an array of transducer elements, excited in precise timing patterns, to produce steering or focusing of the ultrasonic beam over a specific range of angles in the component being inspected. The system consists of a computerized ultrasonic pulser/receiver instrument that contains the collection setup and analysis software, an umbilical cable, and the phased array probe/wedge. The phased inspection may be performed manually, or with an encoder for semi-automated scans, or with a mechanized scanner for fully automated scanning.

The method allows the user the ability to inspect certain portions or zones of the component under test using many different beam angles. The results may be viewed as A-scan, B-scan, C-scan, or as a Sectorial scan images. Multiple views may be viewed simultaneously as well for assistance with data analysis. This technique is also used in a single axis scan motion which makes it more efficient than manual scanning for data collection.

## 9.10 Hardness Testing

### 9.10.1 Hardness Testing for PQR and Production Welds

Hardness testing of the weld and HAZ is often required to assure the welding process, and any PWHT, resulted in an acceptably “soft” result. Testing production welds and HAZ requires test areas to be ground flat or even flush with the base metal to accommodate the hardness testing instrument in the area of interest. The HAZ can be difficult to locate and is often assumed for testing purposes to be just adjacent to the toe of the weld. Hardness testing for a PQR is easier since the coupon is cross-sectioned and etched to identify the weld, fusion line and HAZ. API 582 details

hardness test requirements for PQRs and production welds. High hardness is particularly an issue with hardenable materials where the weld size is small compared to the base metal being welded (i.e. tube-to-tubesheet welds).

Hardness testing of production welds often utilizes portable equipment. Field measurements tend to have greater variability and so additional measurements may be required to verify results. However, hardness testing performed as part of the PQR uses laboratory equipment where greater accuracy is possible. Portable hardness testers are not substitutes for the bench top models, and results from portable testers should be given careful review.

### 9.10.2 Hardness Testing for Repair Welds

On site hardness testing may be required on pressure retaining welds after any PWHT in accordance with API 582 and NACE SP 0472. Hardness testing of repair welds can be conducted with portable hardness testers in accordance with either ASTM A833, ASTM A1038, or ASTM A956

Using API 582 as a reference, the HAZ hardness readings may include locations as close as possible (approximately 0.2 mm) to the weld fusion line (see Figure 57). The surface should be polished and should not exceed 16  $\mu\text{in.}$  (0.4  $\mu\text{m}$ ) maximum. After the surface has been polished, it should be etched to identify the weld metal, fusion line and HAZ.

Hardness measurements may be conducted at locations shown in Figure 57. Five impressions in an area of approximately 1 in.<sup>2</sup> (645 mm<sup>2</sup>) should constitute a test. Because field hardness measurements tend to have greater variability, additional assessment such as “Field Metallography Replication” (FMR) can be conducted to determine whether an excessively hard HAZ microstructure has been formed.

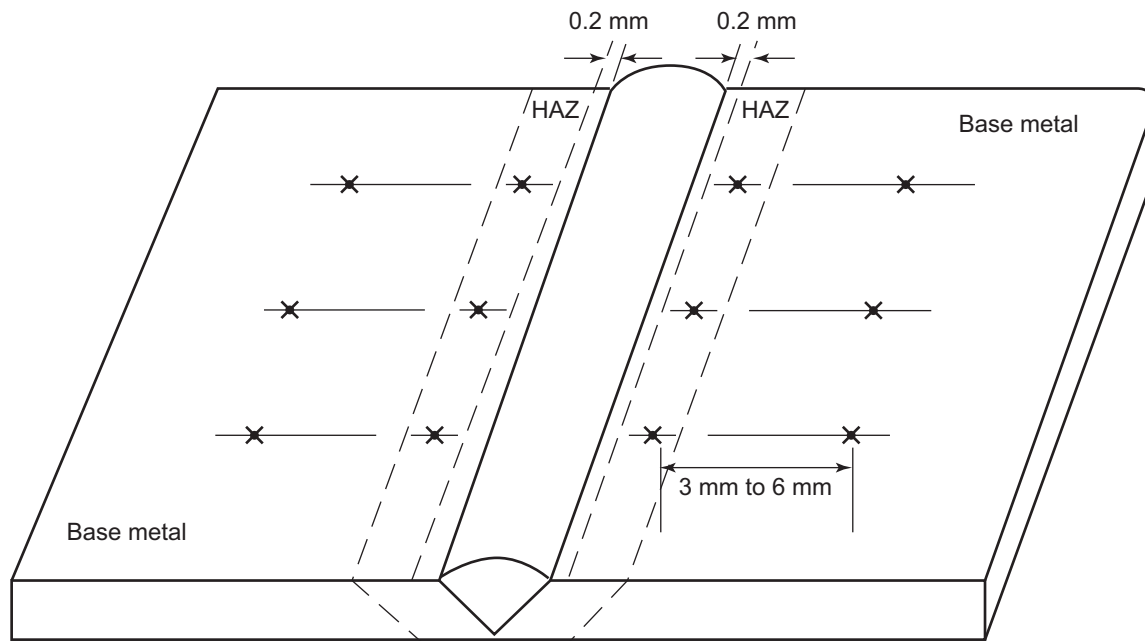

Figure 57—Location of Hardness Measurements

### 9.11 Pressure and Leak Testing (LT)

Where a hydrostatic or pneumatic pressure test is required by code, the inspector should adopt code and specification requirements relevant to vessels or piping. API 510, API 570, API 574, and ASME B31.3 provide guidance on the application of pressure tests. Pressure tests should be conducted at temperatures appropriate for the material of construction to avoid brittle fracture.

Codes and most specifications do not indicate the duration of pressure tests. The test must be held long enough for a thorough visual inspection to be completed to identify any potential leaks. Typically, a pressure test should be held for at least 30 minutes. The inspector should be aware of the effect of changing temperature of the test medium has in causing either an increase or decrease of pressure during the test period.

Pneumatic pressure tests often require special approvals and considerations due to the amount of stored energy in the system. Where pneumatic testing is conducted, the inspector should verify safe pressure-relieving devices, and the cordoning off of test areas to exclude all but essential personnel. The inspector should monitor the pressure at the maximum test level for some time before reducing pressure and performing visual inspection. This safety precaution allows time for a potential failure to occur before the inspector is in the vicinity.

Leak testing may be required by code or specification to demonstrate system tightness or integrity, or may be performed during a hydrostatic pressure test to demonstrate containment on a sealed unit such as a pressure vessel. ASME Section V, Article 10, addresses leak testing methods and indicates various test systems to be used for both open and closed units, based upon the desired test sensitivity. Leak testing of welded tube-to-tubesheet joint may be specified for service applications that are sensitive to small tube-to-tubesheet joint leaks. Helium leak testing is especially effective for tube-to-tubesheet joints when highly sensitive leak testing is required.

One of the most common methods used during hydrostatic testing is the direct pressure bubble test. This method employs a liquid bubble solution, which is applied to the areas of a closed system under pressure. A visual test is then performed to note any bubbles that are formed as the leakage gas passes through it. When performing the bubble test, some items of concern include the temperature of surface to be inspected, pre-test and post-test cleaning of the part to be inspected, lighting, visual aids and the hold time at a specific pressure prior to application of the bubble solution. Typically, the area under test is found to be acceptable when no continuous bubble formation is observed. If the unit under pressure is found to have leakage, it should be depressurized, the leaks repaired as per the governing code, and the test is repeated.

A wide variety of fluids and methods can be used, dependent on the desired result. Considerations for system design limitations may prevent the most common type of leak test using water. Drying, hydrostatic head, and support limitations should be addressed before water is used. The required sensitivity of the results may also lead to a more sensitive leak test media and method.

## **9.12 Weld Inspection Data Recording**

### **9.12.1 Reporting Details**

Results of the weld inspection should be completely and accurately documented. The inspection report, in many cases becomes a permanent record to be maintained and referenced for the life of the weld or part being inspected. Information that might be included in an inspection report is listed in 9.12.1.1, 9.12.1.2, and 9.12.1.3.

#### **9.12.1.1 General Information**

General information reported for weld inspections include:

- a) customer or project,
- b) contract number or site,
- c) date of inspection,
- d) component/system,
- e) subassembly/description,



- f) weld identification,
- g) weld type/material/thickness.

#### **9.12.1.2 Inspection Information**

Inspection information reported on weld inspections include:

- a) date of inspection,
- b) procedure number,
- c) examiner,
- d) examiner certification information,
- e) inspection method,
- f) visual aids and other equipment used,
- g) weld reference datum point.

#### **9.12.1.3 Inspection Results**

Weld inspection results typically reported include:

- a) inspection sheet number;
- b) inspection limitations;
- c) inspection results;
- d) a description of all recordable and reportable indications;
- e) for each recordable indication:
  - 1) indication number;
  - 2) location of indication (from both weld reference datum and centerline);
  - 3) upstream or downstream (clockwise or counterclockwise) from an established reference point;
  - 4) size and orientation of indication;
  - 5) type of indication (linear or rounded);
  - 6) acceptable per the acceptance standards of the referencing code;
  - 7) remarks or notes;
  - 8) include a sketch of indication;
  - 9) reviewer and level of certification;
  - 10) reviewers comments.

### 9.12.2 Terminology

When reporting the results of an inspection it is important to use standard terminology. Examples of standard terminology are shown in Table 8, Table 9, and Table 10.

**Table 8—Conditions that May Exist in a Material or Product**

Definition	Description or Comment
<b>A-1 Indication:</b> A condition of being imperfect; a departure of a quality characteristic from its intended condition.	No inherent or implied association with lack of conformance with specification requirements or with lack of fitness for purpose, i.e. indication may or may not be rejectable.
<b>A-2 Discontinuity:</b> An interruption of the typical structure of a material, such as a lack of homogeneity in its mechanical, metallurgical, or physical characteristics. A discontinuity is not necessarily a defect.	<p>No inherent or applied association with lack of conformance with specification requirements or with lack of fitness for purpose, i.e. imperfection may or may not be rejectable.</p> <p>An unintentional discontinuity is also an imperfection. Cracks, inclusions and porosity are examples of unintentional discontinuities that are also imperfections.</p> <p>Intentional discontinuities may be present in some material or products because of intentional changes in configuration; these are not imperfections and are not expected to be evaluated as such.</p>

**Table 9—Results of Non-destructive Examination**

Definition	Description or Comment
<b>B-1 Indication:</b> The response or evidence from the application of a non-destructive examination.	When the nature or magnitude of the indication suggests that the cause is an imperfection or discontinuity, evaluation is required.

**Table 10—Results of Application of Acceptance/Rejection Criteria**

Definition	Description or Comment
<b>C-1 Flaw:</b> An imperfection or unintentional discontinuity, which is detectable by a non-destructive examination.	No inherent or implied association with lack of conformance with specification requirements or lack of fitness for purpose, i.e. a flaw may or may not be rejectable.
<b>C-2 Defect:</b> A flaw (imperfection or unintentional discontinuity) of such size, shape, orientation, location or property, which is rejectable.	<p>Always rejectable, either for:</p> <ul style="list-style-type: none"> <li>a) Lack of conformance to specification requirements.</li> <li>b) Potential lack of fitness for purpose</li> <li>c) Both</li> </ul> <p>A defect (a rejectable flaw) is by definition a condition, which must be removed or corrected.</p>

## 10 Metallurgy

### 10.1 General

Metallurgy is a complex science but a general understanding of the major principles is important to the inspector, due to the wide variety of base metals that may be joined by welding during the repair of equipment, and the significant impact on the metals resulting from the welding process. The welding process can affect both the mechanical properties and the corrosion resistance properties of the weldment. This section is designed to provide an awareness

of metallurgical effects important to personnel performing inspections, but is not to be considered an in depth resource of metallurgy.

Based on the concept that this section provides a basic understanding, this section does not describe all aspects of metallurgy such as crystalline structures of materials and atomic configurations, which are left to other more complete metallurgy texts.

## **10.2 The Structure of Metals and Alloys**

### **10.2.1 General**

Solid metals are crystalline in nature and all have a structure in which the atoms of each crystal are arranged in a specific geometric pattern. The physical properties of metallic materials including strength, ductility and toughness can be attributed to the chemical make-up and orderly arrangement of these atoms.

Metals in molten or liquid states have no orderly arrangement to the atoms contained in the melt. As the melt cools, a temperature is reached at which clusters of atoms bond with each other and start to solidify developing into solid crystals within the melt. The individual crystals of pure metal are identical except for their orientation and are called grains. As the temperature is reduced further, these crystals change in form eventually touch and where the grains touch an irregular transition layer of atoms is formed, which is called the grain boundary. Eventually the entire melt solidifies, interlocking the grains into a solid metallic structure called a casting.

Knowledge of cast structures is important since the welding process is somewhat akin to making a casting in a foundry. Because of the similarity in the shape of its grains, a weld can be considered a small casting. A solidified weld may have a structure that looks very much like that of a cast piece of equipment. However, the thermal conditions that are experienced during welding produce a cast structure with characteristics unique to welding.

### **10.2.2 Castings**

The overall arrangement of the grains, grain boundaries and phases present in the casting is called the microstructure of the metal. Microstructure is a significant area that inspectors should understand, as it is largely responsible for the physical and mechanical properties of the metal. Because castings used in the refinery industry are typically alloyed, they typically contain two or more microstructural phases. A phase is any structure that is physically and compositionally distinct. As the chemical composition is altered or temperature changed, new phases may form or existing phases may disappear.

Cast structures, depending on their chemical composition can exhibit a wide range of mechanical properties for several reasons. In general, it is desirable to keep the size of grains small, which improves strength and toughness. This can be achieved by maximizing the rate of cooling or minimizing the heat input (in the case of welding). This increases the rate of crystal formation and decreases the time available for crystal growth, which has a net effect of reducing crystalline grain size.

The properties of the cast structure can also be impaired by compositional variations in the microstructure called segregation. Because of the solubility of trace and alloying elements, such elements as carbon, sulfur, and phosphorous, can vary in a pure metal, these elements can cause variations in the solidification temperature of different microstructural phases within the melt. As the melt cools, these elements are eventually contained in the micro structural phases that solidify last in spaces between the grains. These grain boundary regions can have a much higher percentage of trace elements than the grains themselves, which may lead to reductions in ductility and strength properties. This effect can be minimized by using high purity melting stocks, by special melting practices (melting under vacuum or inert gas, for example) to minimize contamination and/or subsequent heat treatment to homogenize the structure. In many carbon steels this is achieved using oxygen scavengers such as aluminum, silicon, or silicon plus aluminum and the steels are often described as “killed” or “fully killed” steels. Minimizing trace elements or “inclusions” at this stage is often important as they can provide sites for formation of in-service defects such as hydrogen assisted cracking.

Gases, such as hydrogen, which become entrapped in the melt as it solidifies, can also affect casting integrity. In some cases, these create voids or porosity in the structure, or can lead to cracking. Weldments are particularly prone to cracking because of trapped hydrogen gases. This problem can be avoided by careful cleaning of the weld bevels to remove hydrocarbons and moisture, the use of low-hydrogen electrodes, correct storage or baking of electrodes and use of proper purging techniques with high quality welding gases.

For refinery applications, castings are used primarily for components having complex shapes in order to minimize the amount of machining required. These include pump components (casings, impellers, and stuffing boxes) and valve bodies.

### 10.2.3 Wrought Materials

The vast majority of metallic materials used for the fabrication of refinery and chemical plant equipment are used in the wrought form rather than cast. Mechanical working of the cast ingot produces wrought materials by processes such as rolling, forging, or extrusion, which are normally performed at an elevated temperature. These processes result in a microstructure that has a uniform composition, and a smaller, more uniform grain shape.

Wrought materials may consist of one or more microstructural phases that may have different grain structures. Austenitic stainless steels, for example, are composed of microstructural phase call austenite, which has grains of the same crystal structure. Many nickel, aluminum, titanium, and copper alloys are also single-phase materials. Single-phase materials are often strengthened by the addition of alloying elements that lead to the formation of nonmetallic or intermetallic precipitates. The addition of carbon to austenitic stainless steels, for example, leads to the formation of very small iron and chromium carbide precipitates in the grains and at grain boundaries. The effect of these precipitates is to strengthen the alloy. However, the formation of chromium carbide precipitates on the grain boundaries during welding (or other high temperature exposure) depletes the area adjacent to the grain boundaries of chromium. This microstructure in austenitic stainless steel is referred to as a "sensitized microstructure". As a result, the chromium-depleted area adjacent to the grain boundary may experience severe intergranular corrosion. In general, greater strengthening occurs with the finer distribution of precipitates. This effect is usually dependent on temperature; at elevated temperatures, the precipitates begin to breakdown and the strengthening effect is lost.

Alloys may also consist of more than one microstructural phase and crystal structure. A number of copper alloys including some brasses are composed of two distinct phases. Plain carbon steel is also a two-phase alloy. One phase is a relatively pure form of iron called ferrite. By itself, ferrite is a fairly weak material. With the addition of more than 0.06 % carbon, a second phase called pearlite is formed which adds strength to steel. Pearlite is a lamellar (i.e. plate-like) mixture of ferrite and  $\text{Fe}_3\text{C}$  iron carbide.

As a result of fast cooling such as quenching in non-alloyed steels and also with the addition of alloying elements such as chromium to steel, other phases may form. Rather than pearlite, phases such as bainite or martensite may be produced. These phases tend to increase the strength and hardness of the metal with some loss of ductility. The formation of structures such as bainite and martensite may also be the result of rapid or controlled cooling and reheating within certain temperature ranges often termed "quenching" and "tempering."

### 10.2.4 Welding Metallurgy

Welding metallurgy is concerned with melting, solidification, gas-metal reactions, slag-metal reactions, surface phenomena and base metal reactions. These reactions occur very rapidly during welding due to the rapid changes in temperature caused by the welding process. This is in contrast to metallurgy of castings, which tends to be slower and often more controlled. There are three parts of a weld: the weld metal, heat-affected metal (zone), and base metal. The metallurgy of each area is related to the composition of the base and weld metal, the welding process and welding procedures used.

Most typical weld metals are rapidly solidified and, like the structure of a casting described earlier, usually solidify in the same manner as a casting and have a fine grain dendritic microstructure. The solidified weld metal is a mixture of melted base metal and deposited weld filler metal, if used. In most welds, there also can be some segregation of alloy

elements. The amount of segregation is determined by the chemical composition of the weld and the base metal. Consequently, the weld is less homogeneous than the base metal, which can affect the mechanical properties of the weld.

The heat-affected zone (HAZ) is adjacent to the weld and is that portion of the base metal that has not been melted, but whose mechanical properties or microstructure have been altered by the preheating temperature and the heat of welding. There typically is a change in grain size or grain structure and hardness in the HAZ of steel. The size or width of the HAZ is dependent on the heat input used during welding. For carbon steels, the HAZ includes those regions heated to greater than 1350 °F (700 °C). Each weld pass applied has its own HAZ and the overlapping heat affected zones extend through the full thickness of the plate or part welded.

The third component in a welded joint is the base metal. Most of the common carbon and low-alloy steels used for tanks and pressure vessels are weldable. The primary factor affecting the weldability of a base metal is its chemical composition. Each type of metal has welding procedural limits within which sound welds with satisfactory properties can be made. If these limits are wide, the metal is said to have good weldability. Conversely, if the limits are narrow, the metal is said to have poor weldability.

An important aspect of welding metallurgy is the gas metal reaction between the molten weld metal and gases present during welding. Gas metal reactions depend on the presence of oxygen, hydrogen, or nitrogen, individually or combined in the shielding atmosphere. Oxygen can be drawn in from the atmosphere or occur from the dissociation of water vapor, carbon dioxide, or metal oxide. Air is the most common source of nitrogen, but it can also be used a shielding gas for welding of austenitic or duplex stainless steels. There are many sources of hydrogen. In SMAW or SAW, hydrogen may be present as water in the electrode coating or loose flux. Hydrogen can also come from lubricants, water on the work piece, surface oxides, or humidity or rain.

An important factor in selecting shielding gases is the type or mixture. A reactive gas such as carbon dioxide can break down at arc temperatures into carbon and oxygen. This is not a problem on carbon and low-alloy steels. However, on high-alloy and reactive metals, this can cause an increase in carbon content and the formation of oxides that can lower the corrosion resistant properties of the weld. High-alloy materials welded with gas-shielded processes usually employ inert shielding gases or mixtures with only slight additions of reactive gases to promote arc stability.

## **10.3 Physical Properties**

### **10.3.1 General**

The physical properties of base metals, filler metals and alloys being joined can have an influence on the efficiency and applicability of a welding process. The nature and properties of gas shielding provided by the decomposition of fluxing materials or the direct introduction of shielding gases used to protect the weldment from atmospheric contamination can have a pronounced effect on its ability to provide adequate shielding and on the final chemical and mechanical properties of a weldment.

The physical properties of a metal or alloy are those, which are relatively insensitive to structure and can be measured without the application of force. Examples of physical properties of a metal are the melting temperature, the thermal conductivity, electrical conductivity, the coefficient of thermal expansion, and density.

### **10.3.2 Melting Temperature**

The melting temperature of different metals is important to know because the higher the melting point, the greater the amount of heat that is needed to melt a given volume of metal. This is seldom a problem in arc welding since the arc temperatures far exceed the melting temperatures of carbon and low-alloy steels. The welder simply increases the amperage to get more heat, thus controlling the volume of weld metal melted per unit length of weld at a given, voltage or arc length and travel speed.

A pure metal has a definite melting temperature that is just above its solidification temperature. However, complete melting of alloyed materials occurs over a range of temperatures. Alloyed metals start to melt at a temperature, which is just above its solidus temperature, and, because they may contain different metallurgical phases, melting continues as the temperature increases until it reaches its liquidus temperature.

### **10.3.3 Thermal Conductivity**

The thermal conductivity of a material is the rate at which heat is transmitted through a material by conduction or thermal transmittance. In general, metals with high electrical conductivity also have high thermal conductivity. Materials with high thermal conductivity require higher heat inputs to weld than those with lower thermal conductivity and may require a pre-heat. Steel is a poor conductor of heat as compared with aluminum or copper. As a result it takes less heat to melt steel. Aluminum is a good conductor of heat and has the ability to transfer heat very efficiently. This ability of aluminum to transfer heat so efficiently also makes it more difficult to weld with low temperature heat sources.

The thermal conductivity of a material decreases as temperatures increase. The alloying of pure metals also decreases a materials thermal conductivity. Generally, a material that has had substantial alloying elements added would have a lower thermal conductivity and lower heat inputs are required to raise the material to a desired temperature.

### **10.3.4 Electrical Conductivity**

The electrical conductivity of a material is a measure of its efficiency in conducting electrical current. Metals are good conductors of electricity. Metals that have high electrical conductivity are more efficient in conducting electrical current than those with a low electrical conductivity.

Aluminum and copper have high electrical conductivity as compared to iron and steel. Their electrical resistance is also much lower, and as a result, less heat is generated in the process of carrying an electrical current. This is one of the reasons that copper and aluminum are used in electric wiring and cables.

The ability of steel to carry an electrical current is much less efficient and more heat is produced by its high measure of electrical resistance. One can then deduce that steel can be heated with lower heat inputs than that necessary for aluminum or copper because of its lower measure of electrical conductivity and higher electrical resistance.

### **10.3.5 Coefficient of Thermal Expansion**

As metals are heated there is an increase in volume. This increase is measured in linear dimensions as the temperature is increased. This linear increase with increased temperature, per degree, is expressed as the coefficient of thermal expansion. An example of this would be the increased length of a steel bar that has been heated in its middle with an oxyfuel torch. As the bar is heated, there is a measurable increase in length that correlates to the temperature and the specified coefficient of thermal expansion for the material at that temperature.

This coefficient of thermal expansion may not be constant throughout a given temperature range because of the phase changes a material experiences at different temperatures and the increases or decreases in volume that accompany these phase changes.

Metals with a high coefficient of thermal expansion are much more susceptible to warping and distortion problems during welding. The increases in length and shrinkage that accompany the heating and cooling during welding should be anticipated, and procedures established which would assure that proper tolerances are used to minimize the effects of thermal conditions. The joining of metals in which their coefficients of thermal expansion differ greatly can also contribute to thermal fatigue conditions, and result in a premature failure of the component. Welding procedures are often employed, which specify special filler metals that minimize the adverse effects caused by inherent differences between the metals being joined.

### 10.3.6 Density

The density of a material is defined as its mass per unit volume. Castings, and therefore welds, are usually less dense than the wrought material of similar composition. Castings and welds contain porosity and inclusions that produce a metal of lower density. This is an important factor employed during RT of welded joints.

The density of a metal is often important to a designer, but more important to the welder is the density of shielding gases. A gas with a higher density is more efficient as a shielding gas than one of a lower density as it protects the weld environment longer before dispersion.

## 10.4 Mechanical Properties

### 10.4.1 General

The mechanical properties of base metals, filler metals and of completed welds are of major importance in the consideration of the design and integrity of welded structures and components. Engineers select materials of construction that provide adequate strength at operating temperatures and pressures. For the inspector, verification that mechanical properties meet the design requirements is essential. Inspectors should understand the underlying principles of mechanical properties and the nature of tests conducted to verify the value of those properties. This is one of the fundamental principles of performing welding procedure qualification tests. Examples of mechanical properties of metals and alloys are: the tensile strength, yield strength, ductility, hardness, and toughness.

### 10.4.2 Tensile and Yield Strength

Tensile testing is used to determine a metals ultimate tensile strength, yield strength, elongation and reduction in area. A tensile test is performed by pulling a test specimen to failure with increasing load.

Stress is defined as the force acting in a given region of the metal when an external load is applied. The nominal stress of a metal is equal to the tensile strength. The ultimate tensile strength of a metal is determined by dividing the external load applied by the cross sectional area of the tensile specimen.

Strain is defined as the amount of deformation, change in shape, a specimen has experienced when stressed. Strain is expressed as the length of elongation divided by the original length of the specimen prior to being stressed.

When the specimen is subjected to small stresses, the strain is directly proportional to stress. This continues until the yield point of the material is reached. If the stress were removed prior to reaching the yield point of the metal, the specimen would return to its original length and is, considered elastic deformation. However, stress applied above the yield point produces a permanent increase in specimen length and the yielding is considered plastic deformation. Continued stress may result in some work hardening with an increase in the specimen strength. Uniform elongation will continue, and the elongation begins to concentrate in one localized region within the gauge length, as does the reduction in the diameter of the specimen. The test specimen is said to begin to "neck down." The necking-down continues until the specimen can no longer resist the stress and the specimen separates or fractures. The stress at which this occurs is called the ultimate tensile strength.

For design purposes, the maximum usefulness should be based on the yield strength of a material, as this is considered the elastic/plastic zone for a material, rather than only on the ultimate tensile strength or fracture strength of a material.

### 10.4.3 Ductility

In tensile testing, ductility is defined as the ability of a material to deform plastically without fracturing, measured by elongation or reduction of area.

Elongation is the increase in gauge length, measured after fracture of the specimen within the gauge length, usually expressed as a percentage of the original gauge length. A material's ductility, when subjected to increasing tensile loads, can be helpful to the designer for determining the extent to which a metal can be deformed without fracture in metal working operations such as rolling and extrusion.

The tensile specimen is punch marked in the central section of the specimen, and measured, and the diameter of the reduced area prior to subjecting it to the tensile load is measured. After the specimen has been fractured, the two halves of the fractured tensile specimen are fitted back together as closely as possible, and the distance between the punch marks is again measured. The increase in the after-fracture gauge length as compared to the original gauge length prior to subjecting the specimen to tensile loads is the elongation of the specimen. This is usually expressed as the percentage of elongation within 2 in. (50.8 mm) of gauge length. The diameter at the point of fracture is also measured and the reduction in area from the original area is calculated. This reduction in area is expressed as a percentage. Both the elongation and the reduction in area percentage are measures of a material's ductility.

The design of components can be based on yield strength as well as tensile strength. Permanent deformation, resulting from plastic flow, occurs when the elastic limit is exceeded. A material subjected to loads beyond its elastic limit may become strain hardened, or work hardened. This results in a higher effective yield strength, however, the overall ductility based on the strain hardened condition is lower than that of a material which has not been subjected to loads exceeding the elastic limit. Some materials also deteriorate in terms of ductility due to thermal cycling in service. Reduction in ductility in these cases may fall so far that in-service repair welding without cracking becomes very difficult if not impossible. This is sometimes experienced during the repair welding of complex alloy exchanger tubesheets.

One of the most common tests used in the development of welding procedures is the bend test. The bend test is used to evaluate the relative ductility and soundness of welded joint or weld test specimen. The specimen is usually bent in a special guided test jig. The specimens are subjected to strain at the outer fiber by bending the specimen to a specified radius that is based on the type of material and specimen thickness. Codes generally specify a maximum allowable size for cracks in a bend specimen. Cracks and tears resulting from a lack of ductility or discontinuities in the weld metal are evaluated for acceptance or rejection to the applicable code requirements.

#### **10.4.4 Hardness**

The hardness of a material is defined as the resistance to plastic deformation by indentation. Indentation hardness may be measured by various hardness tests, such as Brinell, Rockwell, Knoop and Vickers.

Hardness measurements can provide information about the metallurgical changes caused by welding. In alloy steels, a high hardness measurement could indicate the presence of untempered martensite in the weld or heat-affected zone, while low hardness may indicate an over-tempered condition.

There is an approximate interrelationship among the different hardness test results and the tensile strength of some metals. Correlation between hardness values and tensile strength should be used with caution when applied to welded joints or any metal with a heterogeneous structure.

One Brinell test consists of applying load (force), on a 10 mm diameter hardened steel or tungsten carbide ball to a flat surface of a test specimen by striking the anvil on the Brinell device with a hammer. The impact is transmitted equally to a test bar that is held within the device that has a known Brinell hardness value and through the impression ball to the test specimen surface. The result is an indentation diameter in the test bar and the test specimen surface. The diameters of the resulting impressions are compared and are directly related to the respective hardness's of the test bar and the test specimen.

Rockwell hardness testing differs from Brinell testing in that the hardness number is based on an inverse relationship to the measurement of the additional depth to which an indenter is forced by a heavy (major) load beyond the depth of a previously applied (minor) load.



The Rockwell test is simple and rapid. The minor load is automatically applied by manually bringing the work piece up against the indenter until the “set” position is established. The zero position is then set on the dial gauge of the testing machine. The major load is then applied, and without removing the work piece, the major load is removed, and the Rockwell number then read from the dial.

In Rockwell testing, the minor load is always 10 kg, but the major load can be 60, 100, or 150 kg. Indenters can be diamond cone indenters (commonly known as Brales), or hardened steel ball indenters of various diameters. The type of indenters and applied loads depends on the type of material to be tested.

A letter has been assigned to each combination of load and indenter. Scale is indicated by a suffix combination of H for Hardness, R for Rockwell and then a letter indicating scale employed. For instance, a value of 55 on the C scale is expressed as 55 HRC.

Vickers hardness testing follows the Brinell principle as far as the hardness is calculated from the ratio of load to area of an indentation as opposed to the depth (the Rockwell principle).

In the Vickers hardness test, an indenter of a definite shape is pressed into the work material, the load removed, and the diagonals of the resulting indentation measured. The hardness number is calculated by dividing the load by the surface area of the indentation. The indenter for the Vickers test is made of diamond in the form of a square-based pyramid. The depth of indentation is about one-seventh of the diagonal length. The Vickers hardness value is preceded by the designation (HV). The Vickers hardness number is the same as the diamond pyramid hardness number (DPH).

In-service hardness testing may involve the use of portable variations of the above-described methods. Alternatively, varying techniques based on rebound, indentation resistance or comparator indentations may be applied and the results related to the hardness scales more commonly accepted. Whatever technique is employed may well be acceptable as long as it produces verifiable and consistent results.

Various codes and standards place hardness requirements on metals and welds. One should compare test results for the material or welding procedures with the applicable standards to assure that the requirements for hardness testing are being met, and that the test results are satisfactory with that specified by the applicable code. There are often in-service degradation requirements, which are hardness related. For example, susceptibility to wet H<sub>2</sub>S cracking in carbon steel is reduced if hardness levels are maintained below HRC 22.

#### **10.4.5 Toughness**

The toughness is the ability of a metal to absorb energy and deform plastically before fracturing. An important material property to tank and pressure vessel designers is the “fracture toughness” of a metal which is defined as the ability to resist fracture or crack propagation under stress. It is usually measured by the energy absorbed in a notch impact test. There are several types of fracture toughness tests. One of the most common is a notched bar impact test called the Charpy impact test. The Charpy impact test is a pendulum-type single-blow impact test where the specimen is supported at both ends as a simple beam and broken by a falling pendulum. The energy absorbed, as determined by the subsequent rise of the pendulum, is a measure of the impact strength or notch toughness of a material. The tests results are usually recorded in foot-pounds. The type of notch and the impact test temperature are generally specified and recorded, in addition to specimen size (if they are sub-size specimens, smaller than 10 mm x 10 mm).

Materials are often tested at various temperatures to determine the ductile to brittle transition temperature. Many codes and standards require impact testing at minimum design metal temperatures based on service or location temperatures to assure that the material has sufficient toughness to resist brittle fracture.

#### **10.5 Preheating**

Preheating, for our purposes, is defined as heating of the weld and surrounding base metal to a predetermined temperature prior to the start of welding. The primary purpose for preheating carbon and low-alloy steels is to reduce

the tendency for hydrogen induced delayed cracking. It does this by slowing the cooling rate, which helps prevent the formation of martensite in the weld and base metal HAZ. However, preheating may be performed for many reasons, including the following.

- a) Bring temperature up to preheat or interpass temperatures required by the WPS.
- b) Reduce shrinkage stresses in the weld and base metal, which is especially important in weld joints with high restraint.
- c) Reduce the cooling rate to prevent hardening and a reduction in ductility of the weld and base metal HAZ.
- d) Maintain weld interpass temperatures.
- e) Eliminate moisture from the weld area.
- f) Meet the requirements of the applicable fabrication code, such as the ASME Boiler and Pressure Vessel Code, depending on the chemistry and thickness of the alloy to be welded.

If preheat is specified in the WPS it is important that the inspector confirms that the required temperature is maintained. This can be done using several methods, including thermocouples, contact pyrometer, infrared temperature measuring instruments, or temperature indicating crayons. The inspector should also remember that if preheat is required during welding the same preheat should be applied during tack welding, arc gouging and thermal cutting of the metal, all of which induce temperature changes similar to welding of the joint.

Preheat can be applied using several different techniques, but the most common techniques used in pipe and tank fabrication are electrical resistance coils, or an oxy-acetylene or natural gas torch. Good practice is to uniformly heat an area on either side of the weld joint for a distance three times the width of the weld. Preheat should be applied and extend to at least 2 in. (50.8 mm) on either side of the weld to encompass the weld and potential heat affected zone areas. Inspectors should exercise caution when welding metals of different chemistries or preheat requirements ensuring that preheats for both metals are in accordance with codes and the WPS documentation. Typically, the metal with the highest preheat requirement governs.

Some alloys require controlled cooling or extended heating after weld completion, before PWHT begins. ASME IX defines this as "preheat maintenance". Continuous or special heating during welding may also be necessary to avoid cracking.

## 10.6 Postweld Heat Treatment

Postweld heat treatment (PWHT) produces both mechanical and metallurgical effects in carbon and low-alloy steels that varies widely depending on the composition of the steel, its past thermal history, the temperature and duration of the PWHT and heating and cooling rates employed during the PWHT. The need for PWHT is dependent on many factors including; chemistry of the metal, thickness of the parts being joined, joint design, welding processes and service or process conditions. The temperature of PWHT is selected by considering the changes being sought in the equipment or structure. For example, a simple stress relief to reduce residual stresses is performed at a lower temperature than a normalizing heat treatment. The holding time at temperature should also be selected to allow the desired time at temperature dependent actions to take place. In some isolated cases holding time and temperature are interchangeable, but small temperature changes have been shown to be equivalent to large changes in holding times.

The primary reason for postweld heat treatment is to relieve the residual stresses in a welded fabrication. In ferritic welds, postweld heat treatment also is conducted to reduce the hardness of the HAZ. Stresses occur during welding due to the localized heating and severe temperature changes that occur. PWHT releases these stresses by allowing the metal to creep slightly at the elevated temperature. However there may also be in-service conditions that require particular PWHT conditions. These may not be so closely detailed in construction specifications and inspectors

should therefore be particularly aware of these potential requirements when allowing, authorizing or inspecting in-service repairs.

PWHT (stress relief) can be applied by electrical resistance heating, furnace heating, or if allowed by the code, local flame heating. Temperatures should be monitored and recorded by thermocouples attached to the part being heated. Multiple thermocouples are often necessary to ensure proper PWHT of all components. Adequate support should be provided during any postweld heat treatment to prevent the sagging that could occur during the heat treatment.

## 10.7 Hardening

Hardening or hardenability is defined as that property of a ferrous alloy that determines the depth and distribution of hardness induced by quenching. It is important to note that there is no close relation between hardenability and hardness, which is the resistance to indentation. Hardness depends primarily on the carbon content of the material, whereas hardenability is strongly affected by the presence of alloying elements, such as chromium, molybdenum and vanadium, and to a lesser extent by carbon content and alloying elements such as nickel, copper and silicon. For example, a standard medium carbon steel, such as AISI 1040 with no alloying elements has a lower hardenability than AISI 4340 low-alloy steel which has the same amount of carbon, but contains small amounts of chromium, nickel, molybdenum and silicon as alloying elements. Other factors can also affect hardenability to a lesser extent than chemical composition; these include grain structure, alloy homogeneity, amount of certain microstructural phases present in the steel and overall micro cleanliness of the steel.

Welding variables, such as heat input, interpass temperature and size of the weld bead being applied all affect the cooling rate of the base metal HAZ which in turn affect the amount of martensite formation and hardness. The cooling rate of the base metal can also be affected by the section size of the base metal being welded, temperature of the metal being welded and weld joint geometry. If the alloying elements which increase hardenability are found in the base metal HAZ, the cooling rate during welding necessary to produce a high hardness HAZ are generally lower than for plain carbon steel without alloying elements.

The simplest means to determine hardenability is to measure the depth to which a piece of steel hardens during quenching from an elevated temperature. There are several standardized tests for determining hardenability. A typical test of hardenability is called a Jominy Bar. In this test, a round bar is heated to a pre-determined elevated temperature until heated evenly through the cross section. The specimen then subjected to rapid quenching by spraying water against the bottom end of the round bar. The hardness of the test specimen is measured as a function of distance away from the surface being quenched. Steels that obtain high hardness well away from the quenched surface are considered to have high hardenability. Conversely, steels that do not harden well away from the quenched surface are considered to have low hardenability.

It may be important for the welding engineer and inspector to understand the hardenability of the steel as it can be an indirect indicator of weldability. Hardenability relates to the amount of martensite that forms during the heating and cooling cycles of welding. This is most evident in the base metal heat affected zone. Significant amounts of martensite formation in the HAZ can lead to hydrogen assisted cracking or a loss in ductility and toughness. Certain steels with high hardenability forms martensite when they are cooled in air. While other steels with low hardenability require much faster cooling rates to form martensite. Knowing the hardenability helps the engineer or inspector determine if pre-heat or postweld heat treatment are required or if a controlled cooling practice may be acceptable to produce a serviceable weld and acceptable properties in the HAZ.

Hardening of the weld and base metal HAZ are important because of hydrogen assisted cracking that occurs in carbon and low-alloy steels. As the hardness of the base metal HAZ increases so does the susceptibility to hydrogen assisted cracking. The hardness limits currently recommended for steels in refinery process service are listed in Table 11. Hardness values obtained in excess of these usually indicate that postweld heat treatment is necessary, regardless of whether specified on the welding procedure specification. In those instances where PWHT is needed, an alternate welding procedure qualified with PWHT is necessary.

Hardness in excess of those listed can result in stress corrosion cracking in service due to the presence of sulfides in the process. The 200 BHN limit for carbon steel is equally as important in sulfur containing oils as is the limit for Cr-Mo steels.

**Table 11—Brinell Hardness Limits for Steels in Refining Services**

Base Metal	Brinell Value
Carbon Steel	200
C- <sup>1</sup> / <sub>2</sub> Mo	225
1- <sup>1</sup> / <sub>4</sub> Cr- <sup>1</sup> / <sub>2</sub> Mo	225
2- <sup>1</sup> / <sub>4</sub> Cr-1 Mo	241
5, 7, 9, Cr-Mo	241
12 Cr	241

## 10.8 Material Test Reports

Materials test reports, sometimes can be a very valuable tool for the inspector and welding engineer. These are typically notarized statements and are legally binding. There are typically two types of test reports, a heat analysis and a product analysis. A heat analysis, or mill certificate, is a statement of the chemical analysis and weight percent of the chemical elements present in an ingot or a billet. An ingot and a billet are the customary shapes into which a molten metal is cast. These shapes are the starting points for the manufacture of wrought shapes by the metal-forming process, such as rolling, drawing forging or extrusion. A product analysis is a statement of the chemical analysis of the end product and is supplied by the manufacturer of the material. These reports can be supplied for any form of material, including wrought products, such as plate, pipe, fittings or tubing, castings and weld filler metals. The product analysis is more useful to the inspector and engineer since it provides a more reliable identification of the actual material being used for new fabrication or repair of existing equipment.

For the purposes of this publication, the information about material test reports pertains to product certificates for carbon, low-alloy steel and stainless steels. However, it should be noted that the material test report documents may include, but are not limited to, the following information:

- a) manufacturer of the heat of material;
- b) date of manufacture;
- c) heat number of the material;
- d) applicable national standard(s) to which the heat conforms, such as ASTM, ASME, or MIL-STD;
- e) heat treatment, if applicable;
- f) chemistry of the heat;
- g) mechanical properties, at a minimum those required by the applicable National Standards;
- h) any other requirement specified by the applicable National Standard;
- i) any supplemental information or testing requested by the purchaser, this may include, but is not limited to:
  - 1) impact strength;
  - 2) ductile to brittle transition temperature determination;

- 3) fracture toughness;
- 4) elevated mechanical property testing (i.e. tensile, hot ductility or creep testing);
- 5) hardenability;
- 6) hardness;
- 7) response to heat treatment (i.e. proposed post fabrication heat treatment such as precipitation hardening, necessary to achieve mechanical properties);
- 8) microstructural analysis, such as grain size evaluation;
- 9) non-destructive examination, such as ultrasonic testing.

The inspector should review the material test report to confirm that the material(s) being used for fabrication of new equipment or repair of existing equipment meet the requirements specified by the user. The welding engineer can also use the information from a materials test report to determine the weldability of the materials to be used, and to recommend proper welding procedures, pre-heat and/or postweld heat treatment. The chemical analysis given in the test report can be used to calculate the carbon equivalent for that material. It is important to note that materials test reports are not generally supplied to the purchaser unless requested. It is good practice for the purchaser to request the mill test reports.

## **10.9 Weldability of Metals**

### **10.9.1 General**

There are entire books devoted to the weldability of metals and alloys. Weldability is a complicated property that does not have a universally accepted definition. The term is widely interpreted by individual experience. The American Welding Society defines weldability as “the capacity of a metal to be welded under the fabrication conditions imposed, into a specific, suitably designed structure, and to perform satisfactorily in the intended service.” Weldability is related to many factors including the following:

- a) the metallurgical compatibility of the metal or alloy being welded, which is related to the chemical composition and microstructure of the metal or alloy, and the weld filler metal used;
- b) the specific welding processes being used to join the metal;
- c) the mechanical properties of the metal, such as strength, ductility and toughness;
- d) the ability of the metal to be welded such that the completed weld has sound mechanical properties;
- e) weld joint design.

### **10.9.2 Metallurgy and Weldability**

A primary factor affecting weldability of metals and alloys is their chemical composition. Chemical composition not only controls the range of mechanical properties in carbon and alloy steels, it has the most influence on the effects of welding on the material. The heat cycles from welding in effect produce a heat treatment on the metal that can have a substantial effect on mechanical properties, depending on the chemical composition of the metal being welded. As noted earlier, each type of metal has welding procedural limits within which sound weldments with satisfactory properties can be fabricated. If these limits are wide, the metal is said to have good weldability. If the limits are narrow, the metal is considered to have poor weldability.

The addition of carbon generally makes the metal more difficult to weld without cracking. Carbon content has the greatest effect on mechanical properties, such as tensile strength, ductility and toughness in the base metal heat affected zone and weldment. Carbon content influences the susceptibility of the metal to delayed cracking problems from hydrogen. The carbon content, or carbon equivalent, of carbon steel determines the necessity for pre-heat and postweld heat treatment.

Alloying elements other than carbon are added to alloy steels for various reasons and can have an influence on the weldability of the metal. Some alloying elements, such as manganese, chromium, nickel and molybdenum are added to provide beneficial effects on strength, toughness, and corrosion resistance. Some of these elements are beneficial in non-heat treated steel while others come into play during heat treatments necessary to produce the desired mechanical properties. These alloying elements can have a strong effect on hardenability, so they can also affect the weldability of the metal being welded.

There are some elements present in carbon and alloy steels that are not deliberately added that can have an affect on weldability. These include sulfur, phosphorus, tin, antimony, and arsenic. These elements are sometimes referred to as tramp elements.

One tool has been developed to help evaluate the weldability of carbon and alloy steel and that is the carbon equivalent (*CE*) equation. The *CE* calculates a theoretical carbon content of the metal and takes into account not only carbon, but also the effect of purposely added alloying elements and tramp elements. Several different equations for expressing carbon equivalent are in use. One common equation is:

$$CE = C + \frac{Mn}{6} + \frac{(Cr + Mo + V)}{5} + \frac{(SI + Ni + Cu)}{15}$$

Typically, steels with a *CE* less than 0.35 require no preheat. Steels with a *CE* of 0.35 to 0.55 usually require preheating, and steels with a *CE* greater than 0.55 require both preheating and a PWHT. However, requirements for preheating should be evaluated by considering other factors such as hydrogen level, humidity, and section thickness.

### 10.9.3 Weldability Testing

One of the best means to determine weldability of a metal or combination of metals is to perform direct weldability testing. Direct tests for weldability are defined as those tests that specify welding as an essential feature of the test specimen. Weldability testing provides a measure of the changes induced by welding in a specified steel property and to evaluate the expected performance of welded joints.

The problem with predicting the performance of structures or welded equipment from a laboratory type test is a complex one since size, configuration, environment and type of loading normally differ. For this reason, no single test can be expected to measure all of the aspects of a property as complex as weldability and most weldments are evaluated by several tests. If tests are to be useful in connection with fabrication, they should be designed to measure the susceptibility of the weld metal-base metal system to such defects as weld metal or base metal cracks, lamellar tearing, and porosity or inclusions under realistic and properly controlled conditions of welding. Selection of a test method may also have to balance time and cost for emergency repairs or shutdown work.

The simplest weldability tests are those that evaluate the strength and ductility of the weld. Tests that evaluate strength include weld tension tests, shear strength, and hardness. Ductility and fracture toughness tests include bend tests and impact tests. These tests evaluate the breaking strength, ductility and toughness of simple weld joints. These tests are the same as tests used for welding procedure and welder qualification to the ASME Boiler and Pressure Vessel Code. If the weldment has adequate strength and ductility, it is usually deemed acceptable for service.

Fabrication weldability tests that incorporate welding into their execution can be broadly classified as restraint cracking tests, lamellar tearing tests, externally loaded cracking tests, underbead cracking tests or simple weld metal

soundness tests. Some of these tests can be used to detect the susceptibility to more than one type of defect, while others are intended as single purpose tests and still others may be go/no-go types of tests.

Weld restraint induces stresses that can contribute to cracking of both the weld and base metal in fabrication welds. This type of cracking occurs when the rigidity of the joint is so severe that the base metal or weld metal strength cannot resist the strains and stresses applied by expansion and contraction of the weld joint. Weld restraint cracking specimen are designed to permit a quantitative variation in restraint under realistic welding conditions so the contribution of the weld metal, base metal and welding processes can be evaluated with respect to contribution to cracking. Typical weld restraint test methods include the Lehigh restraint test, slot test, rigid restraint cracking (RRC) test, and circular weld restraint cracking test.

Another approach to measuring susceptibility to weld cracking is to apply an external load during welding or subsequent to welding. The loading is intended to duplicate or magnify stresses from restraint of a rigid weld joint. The tests provide an ability to control the stress and strain applied to the weld joint and, therefore, provide a relative index of the susceptibility to weld cracking. Test methods that use external loading include the implant test, tension restraint cracking (TRC) test, and vareststraint test. There is also a very specialized test called the Gleeble test that also applies a load to the specimen during heating or melting of the metal.

It is beyond to the scope of this document to describe each test in detail; however, a general overview of different types of tests and what types of defects they can detect are given in Table 12.

**Table 12—Weld Crack Tests**

	Weld Metal Cracking			Base Metal Cracking		
	Solidification	Root & Toe	Microcracks	H-assisted	Stress Relief	Lamellar Tearing
<b>Restraint Tests</b>						
Lehigh Test	x	x	x	x	x	
Slot Test				x		
Tekken Test		x		x		
RRC Test	x	x	x	x		
Circular Weld Test	x	x		x		
<b>Externally Loaded Tests</b>						
Vareststraint Test	x					
Implant Test				x	x	x
TRC Test				x		
<b>Lamellar Tearing Test</b>						
Cantilever Test						x
Cranfield Test						x
<b>Underbead Cracking Test</b>						
Longitudinal Bead Test				x		
Cruciform Test		x		x		
CTS Test				x		

## 10.10 Weldability of high-alloys

### 10.10.1 General

This section gives information about welding of high-alloy metals, such as austenitic stainless steels, precipitation hardening stainless steels and nickel based alloys. These materials are not as common as carbon and low-alloy steels (e.g. 1<sup>1</sup>/<sub>4</sub> Cr-1<sup>1</sup>/<sub>2</sub> Mo through 9 Cr-1 Mo steels), but may still be used in some processes within the oil industry.

### 10.10.2 Austenitic Stainless Steels

Austenitic stainless steels are iron-based alloys that typically contain low carbon, chromium between 15 % to 32 % and nickel between 8 % to 37 %. They are used for their corrosion resistance and resistance to high temperature degradation. Austenitic stainless steels are considered to have good weldability and can be welded using any common welding process or technique. The most important considerations to welding austenitic stainless steels are; solidification cracking, hot cracking, distortion and maintaining corrosion resistance.

Solidification cracking and hot cracking (sometimes called hot shortness) are directly related to weld metal chemistry and the resultant metallurgical phases that form in the weld metal. Cracking mechanism of both solidification cracking and hot cracking is the same. Cracks can occur in various regions of the weld with different orientations. They can appear as centerline cracks, transverse cracks, and as microcracks in the underlying weld metal or adjacent heat affected zone (HAZ). Cracking is primarily due to low melting point liquid phases which allow boundaries to separate under the thermal and shrinkage stresses during weld solidification and cooling.

The most common measure of weldability and susceptibility to hot cracking is the ferrite number of the weld metal. Austenitic welds require a minimum amount of delta ferrite to resist cracking. The amount of ferrite in the weld metal is primarily a function of both base metal and weld metal chemistry. For welds made without filler metal, the base metal chemistry should be appropriate to produce the small amounts of ferrite that is needed to prevent cracking. If the base metal chemistry does not allow for ferrite formation, then filler metal is recommended to produce adequate ferrite in the weld metal. Welding parameters and practices can also effect ferrite formation. For example, small amounts of nitrogen absorbed into the weld metal can reduce ferrite formation. WRC Bulletin 342 contains diagrams that accurately predict the amount of ferrite present in a weld metal based on the calculation of nickel and chromium equivalents based on weld metal and base metal chemistry. A number of resources recommend a minimum of 5% – 20 % ferrite to prevent cracking.

Weldability of austenitic stainless steels can also be affected by the presence of high levels of low melting point elements like sulfur, phosphorus, and selenium. Other elements such as silicon and columbium (niobium) also increases the hot cracking susceptibility of austenitic stainless steels.

Distortion is more often a problem with welding of austenitic stainless steels than carbon or low-alloy steels. The thermal conductivity of austenitic stainless steels is about one third that of carbon steel and the coefficient of thermal expansion is about 30 % greater. This means that distortion is greater for austenitic stainless steels than for carbon steels. More frequent tack welds may be necessary for stainless steels to limit shrinkage.

Welding can reduce the corrosion resistance of regions of the HAZ of some austenitic stainless steels. Areas exposed to temperatures between 800 °F to 1650 °F (427 °C to 900 °C) for a long enough time may precipitate chromium carbides at the grain boundaries. This causes a loss of corrosion resistance due to chromium depletion. Using low-carbon content stainless steels, such as Type 304L or 316L, or stabilized grades of stainless steels, such as Type 321 and 347 can prevent this phenomenon. It is also important to select the proper filler metal to prevent a loss in corrosion resistance. Low carbon electrodes or stabilized grades of bare filler metal should be used.

Oxidation of the backside of welds made without proper shielding can also be detrimental to the corrosion resistance of austenitic stainless steels. To prevent a loss in corrosion resistance the root of the weld should be protected by using an inert backing gas.



### 10.10.3 Nickel Alloys

Nickel alloys, such as Alloy C276 or Alloy 625 suffer from similar problems as austenitic stainless steels. In general most nickel alloy materials are considered to have less weldability than austenitic stainless steels. Some nickel alloys, such as Alloy 825, 600, and 625 have similar welding characteristics to austenitic stainless steels. While Alloy 200, Alloy 400, and Alloy B-2 have very different welding characteristics compared to austenitic stainless steels.

One of the main differences between nickel alloy and carbon steels, and austenitic stainless steels, is their tendency to be sluggish during welding. This means for nickel alloys that the molten weld pool will not move as easily as it does for other metals. This sluggish tendency means the welder should move the weld pool with a weave or oscillation pattern to ensure good sidewall fusion. If some oscillation is not used, a high convex weld contour will result which cause sidewall lack of fusion, weld undercut or slag inclusions. The formation of a slightly concave weld bead profile will be more resistant to centerline cracking. It is also important that the bevel angle for nickel alloys be wide enough to allow for this necessary oscillation of the welding torch. The wider weld bevel will also be beneficial with respect to weld penetration. Nickel alloys also suffer from shallower weld penetration as compared to carbon steels and austenitic stainless steel. To overcome this, the weld joint is modified by having a wider bevel and thinner root face.

Nickel alloys are also susceptible to hot cracking, in some cases more so than austenitic stainless steels. This hot tearing will occur as the weld pool cools and solidifies. To help prevent hot cracking the weld joint should be designed to minimize restraint and the weld should be allowed to cool as quickly as possible. The faster a nickel alloy weld solidifies (freezes), the less time it spends in the temperature range where it can tear. For this reason pre-heating, which slows down the cooling rate of the weld, is actually harmful, as it permits more opportunity for hot tearing to occur.

As with austenitic stainless steels, the weldability of nickel alloys can also be affected by the presence of high levels of low melting point elements like sulfur, phosphorus, zinc, copper and lead. All of these contaminants can lead to cracking in either the weld or base metal.

## 11 Refinery and Petrochemical Plant Welding Issues

### 11.1 General

This section provides details of specific welding issues encountered by the inspector in refineries and petrochemical plants. This section will be expanded as more issues reflecting industry experience are added.

### 11.2 Hot Tapping and In-Service Welding

#### 11.2.1 General

API 2201 provides an in depth review of the safety aspects to be considered when hot tapping or welding on in-service piping or equipment. Prior to performing this work, a detailed written plan should be developed and reviewed. The following is a brief summary of welding related issues.

Two primary concerns when welding on in-service piping and equipment are burn through and cracking. Burn through will occur if the unmelted area beneath the weld pool can no longer contain the pressure within the pipe or equipment. Weld cracking results when fast weld-cooling rates produce a hard, crack-susceptible weld microstructure. Fast cooling rates can be caused by flowing contents inside the piping and equipment, which remove heat quickly.

#### 11.2.2 Electrode Considerations

Hot tap and in-service welding operations should be carried out only with low-hydrogen consumables and electrodes (e.g. E7016, E7018, and E7048). Extra-low-hydrogen consumables such as Exxxx-H4 should be used for welding carbon steels with CE greater than 0.42 % or where there is potential for hydrogen assisted cracking (HAC) such as cold worked pieces, high strength, and highly constrained areas.

Cellulosic type electrodes (e.g. E6010, E6011, or E7010) may be used for root and hot passes. Although low-hydrogen electrodes are preferred, some refining locations and the pipeline industry prefer to use cellulosic electrodes frequently because they are easy to operate and provide improved control over the welding arc. Root pass with low-hydrogen electrodes reduces risk of HAC. It also reduces risk of burn-through because the amount of heat directed to the base metal is less than when using cellulosic type electrodes. However, manipulation of low-hydrogen electrode for root pass is not as easy but it can be done by training and practice. It should be noted that cellulosic electrodes have the following adverse effects on the integrity of the weldment:

- a) Deep penetration, therefore higher risk of burn-through than low-hydrogen electrodes; and
- b) High diffusible hydrogen, therefore higher risk of hydrogen assisted cracking.

### 11.2.3 Flow Rates

Under most conditions, it is desirable to maintain some product flow inside of any material being welded. This helps to dissipate the heat and to limit the metal temperature during the welding operation, thereby reducing the risk of burn-through. Liquid flow rates in piping should be between 1.3 ft/sec. and 4.0 ft/sec. (0.4 m/sec. and 1.3 m/sec.). Faster liquid flow rates may cool the weld area too quickly and thereby cause hard zones that are susceptible to weld cracking or low toughness properties in the weldment. Because this is not a problem when the pipe contains gases, there is no need to specify a maximum velocity. If the normal flow of liquids exceeds these values or if the flow cools the metal to below dew point, it is advisable to compensate by preheating the weld area to at least 70 °F (20 °C) and maintaining that temperature until the weld has been completed. High liquid flow may cause rapid cooling of the weld area during the welding, creating hard zones susceptible to cracking. Under these circumstances, the minimum interpass temperatures may not be attainable, resulting in undesirable material properties.

For making attachment welds to equipment containing a large quantity of liquid such as a storage tank 36 in. (0.9 m) below the liquid/vapor line, normal circulation will effectively cool the weld area.

Welding on a line under no-flow conditions or intermittent-flow conditions, e.g. a flare line, should not be attempted unless it has been confirmed that no explosive or flammable mixture will be generated during the welding operation. In this respect, it should be confirmed that no ingress of oxygen in the line is possible. In cases where this requirement cannot be met, inert gas or nitrogen purging is recommended.

An appropriate flow rate should be maintained to minimize the possibility of burn-through or combustion. The minimum flow rate is 1.3 ft/sec. (0.4 m/sec.) for liquid and gas. For liquids, the maximum flow rate is usually required to minimize risk of high hardness weld zone due to fast cooling rate. The allowable maximum flow rate depends on the process temperature. In general, 4.0 ft/sec. (1.2 m/sec.) is the upper limit. There is no restriction on maximum velocity for gas lines, subject to maintaining preheat temperatures.

### 11.2.4 Other Considerations

#### 11.2.4.1 Burn Through

To avoid overheating and burn through, the welding procedure specification should be based on experience in performing welding operations on similar piping or equipment, and/or be based on heat transfer analysis. Many users establish procedures detailing the minimum wall thickness that can be hot tapped or welded in-service for a given set of conditions like pressure, temperature, and flow rate. Some users include in their procedures the use of mock-up weld coupons when the actual thickness of the material to be welded is less than 1/4 in. The mock-up coupon represents the actual material and thickness, the welding parameters are recorded and the weld penetration is verified by etching. This information becomes the supplement to the repair package. To minimize burn through, the first weld pass to equipment or piping less than 1/4 in. (6.35 mm) thick should be made with 3/32 in. (4.76 mm) or smaller diameter welding electrode to limit heat input. For equipment and piping wall thicknesses where burn through is not a primary concern, a larger diameter electrode can be used. Weaving the bead should also be avoided as this increases the heat input.

### 11.2.4.2 Hot Taps

Adverse effects can also occur from the heat on the process fluid. In addition, welds associated with hot taps or in-service welding often cannot be stress relieved and may be susceptible to cracking in certain environments. Any hot tapping or in-service welding on systems containing those listed in Table 13 should be carefully reviewed.

During repairs or alterations (including hot taps) of alloy material piping systems, material verification of the existing and the new materials is required to establish that the selected components are as specified. Additionally, in some jurisdictions the hot tap component may require to have a registered design in which case this should be verified.

Buttering the surface of the run pipe prior to attaching a hot-tap nozzle is particularly recommended when attaching a nozzle to pipe fabricated from plate material to prevent lamellar tearing of the pipe where the thickness is such that this may occur as the result of weld shrinkage stresses. With in-service welding there is the risk of high hardness and hydrogen cracking in the HAZ of the parent material. Buttering allows a more closely controlled heat input in the parent material, and also permits use of the temper bead welding technique. The temper bead welding technique tempers the HAZ of the parent material during the deposition of the second layer of weld metal. This approach is particularly useful where the cooling effect of the process fluid present is high.

**Table 13—Hot Tapping/In-service Welding Hazards Associated with Some Particular Substances**

Substance	Hot Tapping/In-service Welding Hazard
Acetylene	Explosion or unstable reaction with the addition of localized heat.
Acetonitrile	Explosion or unstable reaction with the addition of localized heat.
Amines and caustic	Stress corrosion cracking due to high thermal stress upon the addition of localized heat and high hardness of non-PWHT's weld. Hydrogen Embrittlement.
Butadiene	Explosion or unstable reaction.
Chlorine	Carbon steel burns in the presence of chlorine and high heat.
Compressed air	Combustion/metal burning.
Ethylene	Exothermic decomposition or explosion.
Ethylene oxide	Exothermic decomposition or explosion.
Hydrogen	High temperature hydrogen attack. Hydrogen assisted cracking.
Hydrogen sulfide (Wet H <sub>2</sub> S)	Stress corrosion cracking due to high hardness of non-PWHT's weld. Hydrogen embrittlement. Pyrophoric scale.
Hydrofluoric acid	Hazardous substance.
Oxygen	Combustion/metal burning.
Propylene	Explosion or unstable reaction.
Propylene oxide	Explosion or unstable reaction.
Steam	High pressure steam can blow out.

Buttering allows a balanced welding sequence to be used, and if correctly applied can reduce the potential distortion of the pipe after welding. Normally, two layers of weld metal should be deposited especially for dissimilar metal welds to reduce the impact of weld dilution. The final thickness of the weld deposit at the location of the nozzle-to-pipe weld should, after grinding, be not less than  $\frac{1}{4}$  in. (3 mm). The width of the buttering should be sufficient to overlap the nozzle attachment weld by  $\frac{1}{4}$  in. (6.5 mm) on both the inside and outside diameters. Similarly, buttering should be deposited under any reinforcement plate-to-pipe welds.

The surface of the buttered layer should be ground smooth, the edges de-burred and both the weld and the pipe local to the weld inspected by appropriate crack detection and ultrasonic methods. It is recommended that immediately before welding is commenced a test be carried out to check the amperage of the welding current to reduce the risk of burn-through of the run pipe during the actual welding operation, This may be done by striking an arc on a suitable piece of material, similar to that of the run pipe.

### 11.2.5 Inspection

Inspection tasks typically associated with hot tapping or welding on in-service equipment should include the following.

- a) Verifying adequate wall thickness along the lengths of the proposed welds typically using UT or RT.
- b) Verifying the welding procedure. Often, plants have welding procedures qualified specifically for hot taps and in-service welding.
- c) Verifying flow conditions.
- d) Specifying the sequence of welding full encirclement sleeves and fittings (circumferential and longitudinal welds).
- e) Verifying fit-up of the hot tap fitting.
- f) Auditing welding to assure the welding procedure is being followed.
- g) Perform NDE of completed welds. Typically this includes VT, UT shear wave using special procedures for the joint configuration, MT or PT as applicable for material and temperature.
- h) Witness leak testing of fitting, if specified.
- i) Perform positive metal identification (PMI) testing on the hot tap component material. Additionally, in some jurisdictions the hot tap component may require to have a registered design in which case this should be verified.

### 11.3 Lack of Fusion with GMAW-S Welding Process

The gas metal arc welding (GMAW) process can utilize various metal transfer modes. When using the low voltage, short circuiting mode (designated by the -S extension), the molten weld puddle is able to freeze more quickly. This allows the unique ability to weld out of position, to weld thin base metals, and to weld open butt root passes. Due to this inherent nature of the welding process the BPV Code Section IX, restricts this process by:

- a) requiring welders qualify with mechanical testing rather than by radiographic examination.
- b) limiting the base metal thickness qualified by the procedure to 1.1 times the test coupon thickness for coupons less than  $\frac{1}{2}$  in. thick (12.7 mm) per variable QW-403.10.
- c) limiting the deposited weld metal thickness qualified by the procedure to 1.1 times the deposited thickness for coupons less than  $\frac{1}{2}$  in. thick (12.7 mm) per variable QW-404-32.
- d) making variable QW-409.2 an essential variable when qualifying a welder for the GMAW-S process.

Since the transfer mode may be difficult to determine without an oscilloscope, some general characteristics are listed in a National Board Classic Bulletin, Low Voltage Short Circuiting—GMAW, from January 1985, to assist the inspector in determining the transfer mode being used. The quick freeze characteristic, which can result in LOF, is the reason this process is frequently written out of purchase requisitions.

GMAW in the short-circuiting transfer mode is of particular significance to inspectors in that many specifications, codes and standards impose limitations or special conditions on its use. The technique can suffer from incomplete fusion particularly in the sidewall of steep or narrow weld preparations. This occurs as transfer of small fast freezing droplets only occurs whilst the electrode is short circuited by contact with the work piece. Intermittent loss of contact can leave areas of lack of fusion. In shallow weld preparations, these are also very difficult to detect with conventional radiographic techniques. Consequently, a higher standard of NDE inspection is required. In pipeline welding, automated ultrasonic has been adopted to overcome this problem. The risk of LOF associated with GMAW-S means restrictions on qualification of welders using radiography only and inspectors should make note of these potential problems.

#### 11.4 Caustic Service

Carbon steel and low alloy steels are subject to stress corrosion cracking in caustic service. Austenitic (i.e. Type-300 series) stainless steels can be sensitive to caustic cracking in high temperature steam environments. Cracking is a function of temperature, caustic concentration, and the level of operating or residual stress. Prior to welding or PWHT, the weld area should be cleaned, for a distance of at least 6 in. (150 mm) from the edges of the weld, with a 5 % acetic acid solution in water and then water wash to removed the neutralized caustic. Check the cleaned area with pH paper to show that the caustic has been removed. Alternatively, the area can be checked with a phenolphthalein indicator to show that caustic has been removed. If the indicator turns pink, caustic is still present on the surface. The contaminated surface should be reneutralized, recleaned and rechecked, as necessary, until caustic is removed from the surface. Material cleanliness is a very important requirement for successful welding, especially when welding nickel and nickel alloy materials. Inspection should be performed before welding on caustic contaminated surfaces. All areas to be welded should be ground or power-brush clean. Nickel and nickel alloys should be cleaned with a stainless steel wire brush. All cleaning tools including wire brushes and carbide grinding tools should be clean and free of debris or other metal fragments. Care should be taken during grinding operations since the heat of grinding may create and propagate crack-like defects on caustic-contaminated surfaces.

Welds and steel cold formed areas should be postweld heat treated if service conditions are anticipated to exceed 120 °F (49 °C) for 50 % caustic soda solution. Cracking can be effectively prevented by means of a stress-relieving heat treatment (e.g. PWHT). Heat treatment, at or above 1150 °F, is considered an effective stress relieving heat treatment for carbon steel to resist caustic stress corrosion cracking. Although caustic stress corrosion cracks may be seen visually, crack detection is best performed with WFMT, ET, RT, or ACFM techniques. Surface preparation by grit blasting, high pressure water blasting, or other methods is usually required.

Prior to weld repairs in caustic service, a corrosion specialist should review the details of welding plan to assure suitability for service. This should include a review of the welding electrode/wire selected, the weld procedure, details of weld preparation, post-weld heat treatment, and the details of the NDE to be used on the completed welds. Other service that may warrant similar review include amine service, hydrofluoric acid service, hydrogen service, sour and wet H<sub>2</sub>S service, and situations with dissimilar metal welds.

## **Annex A** **(normative)**

### **Terminology and Symbols**

#### **A.1 Weld Joint Types**

Figure A.1 illustrates the various weld joint types that are typically encountered by the inspector. The type of joint can affect the type of weld process that can be used and on choice of NDE method.

#### **A.2 Weld Symbols**

Engineering and construction drawings often use standard symbols to represent weld details. Figure A.2 shows the corresponding symbols for several weld joint types. Figure A.3 shows some supplementary symbols that provide specific detail about the weld. Figure A.4 explains the conventions used in a weld symbol.

#### **A.3 Weld Joint Nomenclature**

Standard terminology applies to the various components of a weld joint. Figure A.5 illustrates and describes the joint terminology.

#### **A.4 Electrode Identification**

The AWS specification and classification system allows selection of an electrode, which will provide a weld metal with specific mechanical properties and alloy composition. The following welding processes use an electrode identification system to designate characteristics of the electrode: SMAW, GMAW, GTAW, FCAW, SAW, and EGW. The identification systems are explained for each process in Figure A.6, Figure A.7, Figure A.8, Figure A.9, and Figure A.10.

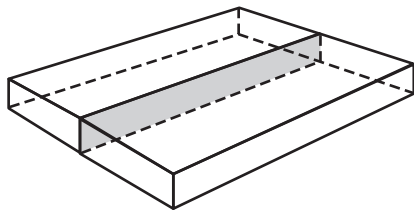

(A) Butt Joint

- Applicable Welds
- |                    |             |
|--------------------|-------------|
| Bevel-groove       | U-groove    |
| Flare-bevel-groove | V-groove    |
| J-groove           | Edge-flange |
| Square-groove      | Braze       |

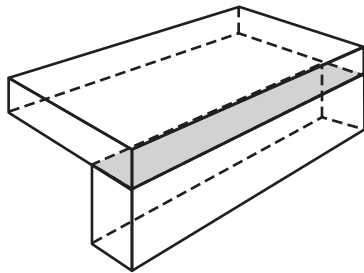

(B) Corner Joint

- Applicable Welds
- |                    |            |
|--------------------|------------|
| Fillet             | V-groove   |
| Bevel-groove       | Plug       |
| Flare-bevel-groove | Slot       |
| Flare-V-groove     | Spot       |
| J-groove           | Seam       |
| Square-groove      | Projection |
| U-groove           | Braze      |

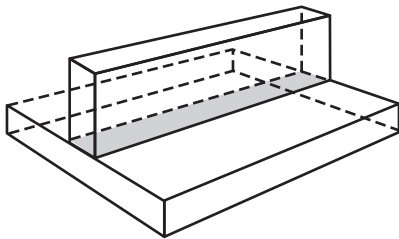

(C) T-Joint

- Applicable Welds
- |                    |            |
|--------------------|------------|
| Fillet             | Slot       |
| Bevel-groove       | Spot       |
| Flare-bevel-groove | Seam       |
| J-groove           | Projection |
| Square-groove      | Braze      |
| Plug               |            |

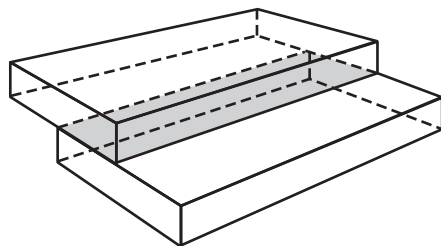

(D) Lap Joint

- Applicable Welds
- |                    |            |
|--------------------|------------|
| Fillet             | Slot       |
| Bevel-groove       | Spot       |
| Flare-bevel-groove | Seam       |
| J-groove           | Projection |
| Plug               | Braze      |

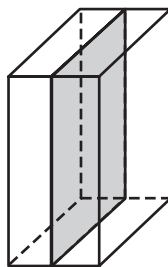

(E) Edge Joint

- Applicable Welds
- |                    |          |
|--------------------|----------|
| Bevel-groove       | U-groove |
| Flare-bevel-groove | V-groove |
| Flare-V-groove     | Edge     |
| J-groove           | Seam     |
| Square-groove      |          |

Figure A.1—Joint Types and Applicable Welds

Groove							
Square	Scarf	V	Bevel	U	J	Flare-V	Flare-bevel

Fillet	Plug or slot	Stud	Spot or projection	Seam	Back or backing	Surfacing	Flange	
							Edge	Corner

NOTE The reference line is shown dashed for illustrative purposes.

Figure A.2—Symbols for Various Weld Joint

Weld all around	Field weld	Melt through	Consumable insert (square)	Backing or spacer (rectangle)	Contour		
					Flush or flat	Convex	Concave

Figure A.3—Supplementary Symbols for Welds



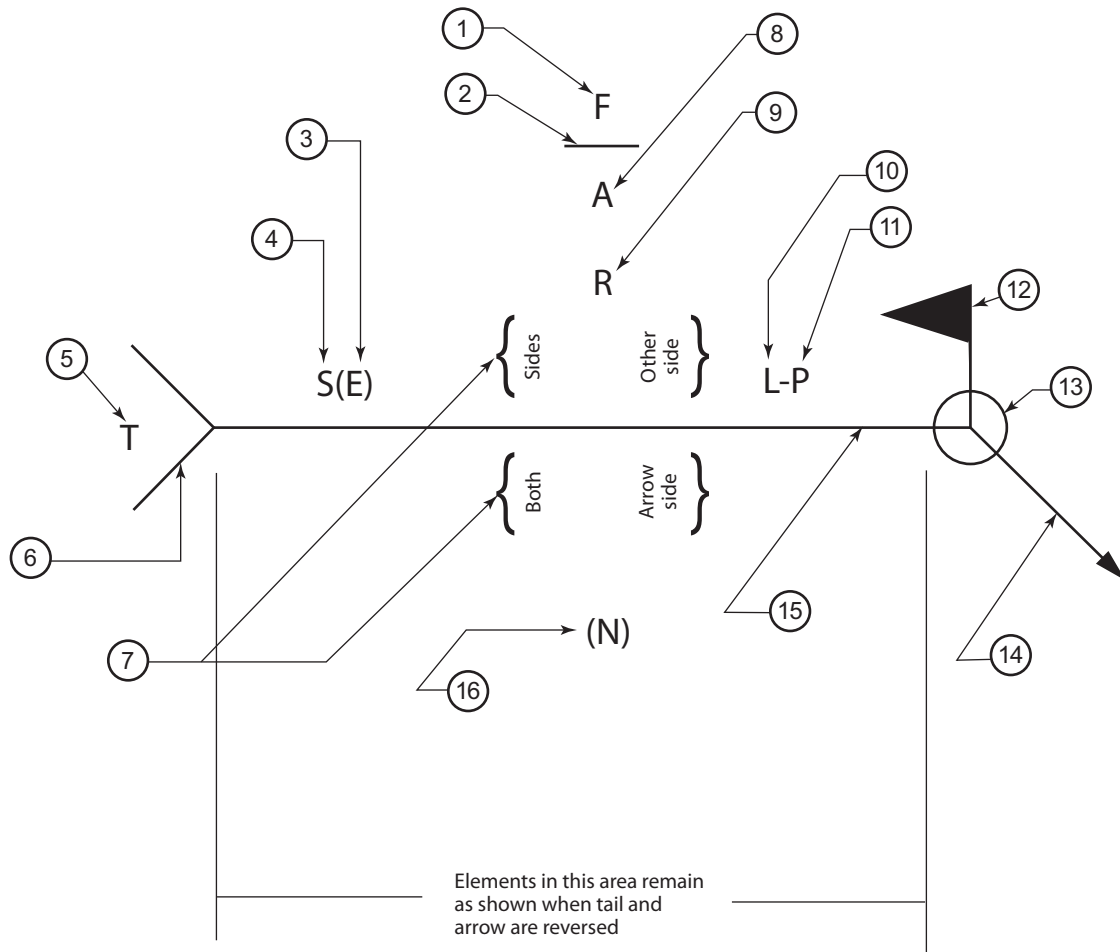

**Key**

- |   |  |    |  |
|---|--|----|--|
| 1 | finish symbol  | 9  | Root opening; depth of filling for plug and slot welds                               |
| 2 | contour symbol   | 10 | length of weld   |
| 3 | groove weld size   | 11 | pitch (center-to-center spacing) of welds  |
| 4 | depth of bevel; size or strength for certain welds         | 12 | field weld symbol  |
| 5 | specification, process, or other reference                 | 13 | weld-all-around symbol   |
| 6 | tail (omitted when reference is not used)                  | 14 | arrow connecting reference line to arrow side member of joint or arrow side of joint |
| 7 | weld symbol  | 15 | reference line   |
| 8 | groove angle; included angle of countersink for plug welds | 16 | number of spot, seam, stud, plug, slot, or project welds                             |

**Figure A.4—Standard Weld Symbols**

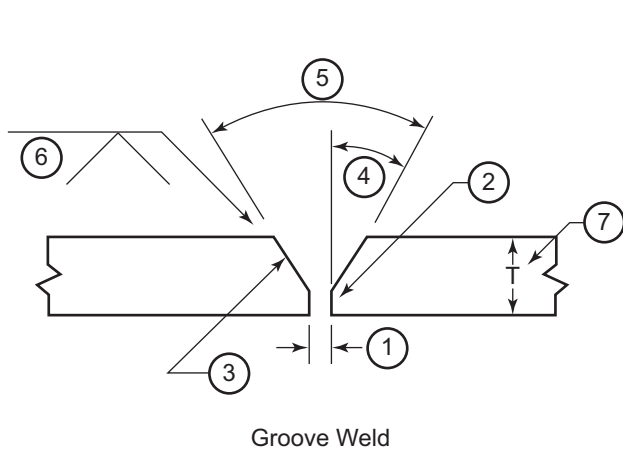

Key

- 1. Root Opening: A separation at the joint root between the workpieces.
- 2. Root Face: That portion of the groove face adjacent to the joint root.
- 3. Groove Face: The surface of a joint member included in the groove.
- 4. Bevel Angle: The angle formed between the prepared edge of a member and a plane perpendicular to the surface of the member.
- 5. Groove Angle: The total included angle of the groove between workpieces.
- 6. Groove Weld Size: The joint penetration of a groove weld.
- 7. Plate Thickness (T): Thickness of the base metals to be welded.

**Figure A.5—Groove Weld Nomenclature**

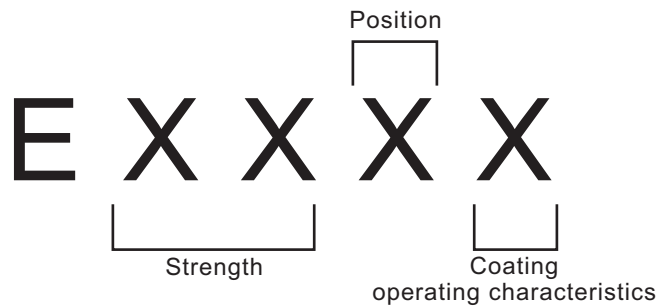

**Figure A.6—SMAW Welding Electrode Identification System**

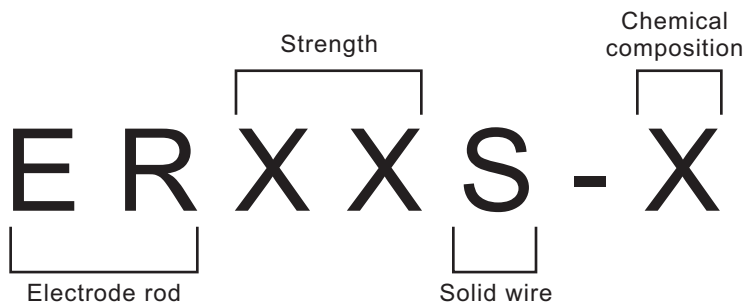

**Figure A.7—GMAW/GTAW/PAW Welding Electrode Identification System**

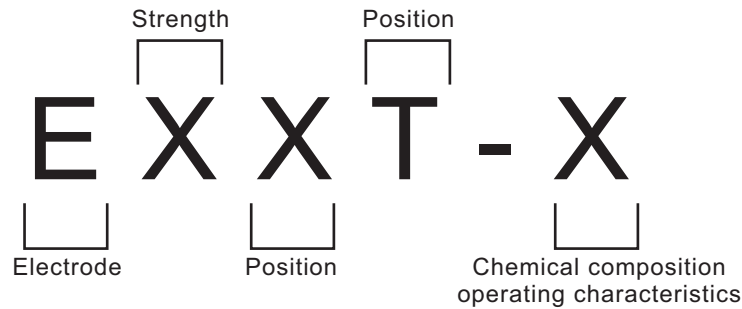

**Figure A.8—FCAW Welding Electrode Identification System**

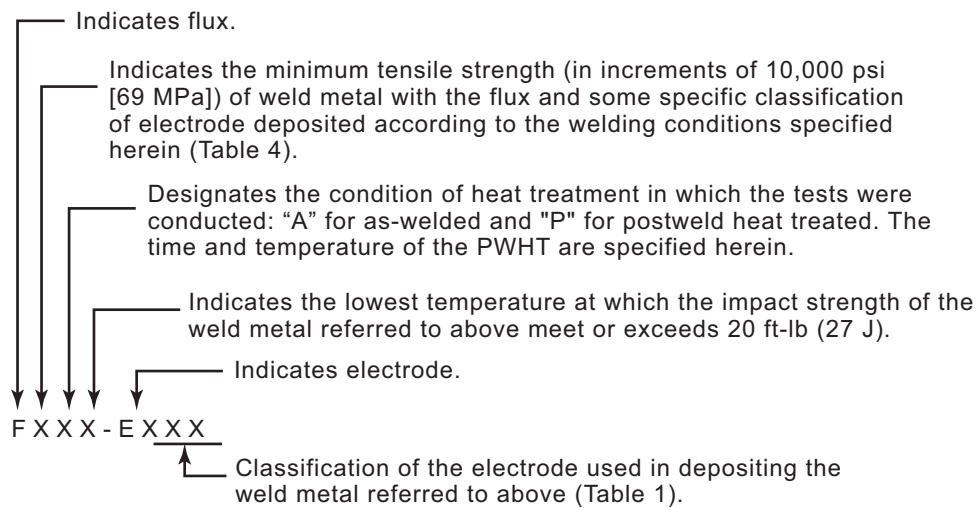

**EXAMPLE**

F7A6-EM12K is a complete designation. It refers to a flux that will produce weld metal which, in the as-welded condition, will have a tensile strength no lower than 70,000 psi and Charpy V-notch impact strength of at least 20 ft-lb at -60 °F when deposited with an EM12K electrode under the conditions called for in this specification.

**Figure A.9—SAW Welding Electrode Identification System**

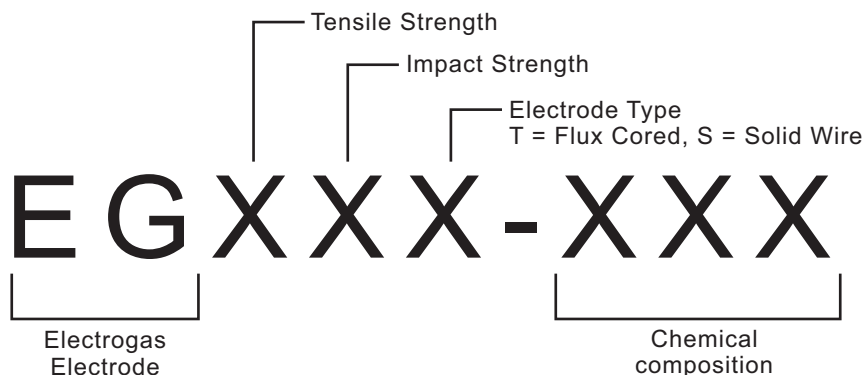

**Figure A.10—EGW Welding Electrode Identification System**

## Annex B (normative)

### Actions to Address Improperly Made Production Welds

Production welds made by an unqualified welder or an improper welding procedure should be addressed to assure the final weldments meet the service requirements. A welder may be unqualified for several reasons including expired qualification, not qualified for the thickness, not qualified in the technique, or not qualified for the material of construction. Figure B.1 details some potential steps to address the disposition of these welds.

A welding procedure may be improper if the weldment is made outside the range of essential variables (and supplementary essential variables, if required) qualified for the WPS. Figure B.2 details some potential steps to address weldments made with an improper welding procedure.

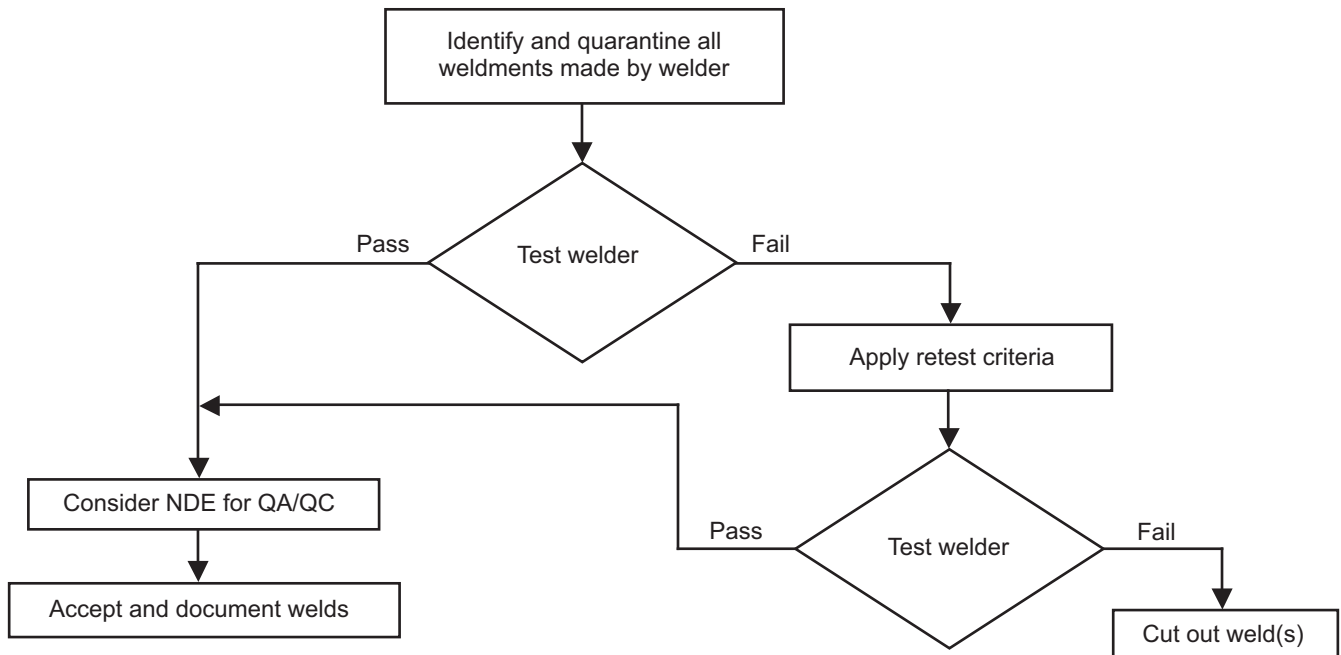

- Potential causes:
- Qualification expired.
  - Not qualified in range.
  - Not qualified in method.
  - Not qualified in material.

Figure B.1—Suggested Actions for Welds Made by an Incorrect Welder

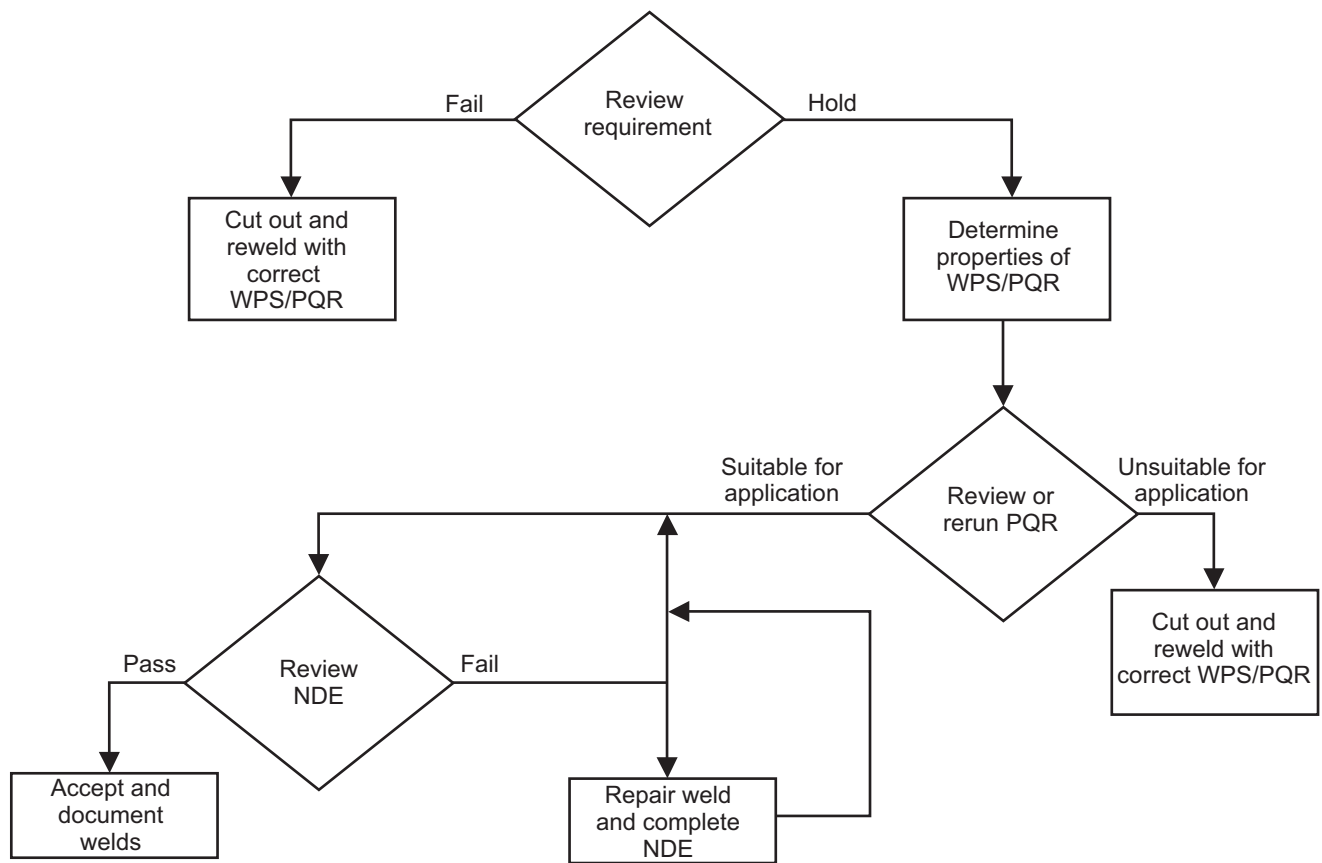

**Figure B.2—Steps to Address Production Welds Made by an Improper Welding Procedure**

## Annex C (informative)

### Welding Procedure Review

#### C.1 General

This Annex presents a sample checklist prepared by a mythical company named Company Inc. to evaluate a WPS and PQR for a SMAW process. There is no ASME code requirement for a checklist; however, code users and reviewers must be certain that every variable as specified in paragraph QW-250 of ASME Section IX is addressed.

The checklist presented in this Annex is representative of other lists available in the CASTI “Guidebook to ASME Section IX—Welding Qualifications.” A narrative discussing each variable, potential problem, and where the procedure supports the application and each other is included.

#### C.2 Example of Using a Checklist to Review a WPS & PQR

Figure C.1 is a sample WPS #CS-1 and Figure C.2 is a sample PQR #CS-1 prepared by a mythical company, named: Company Inc. Figures C.1 and C.2 are samples that contain typical errors in the documentation. Figure C.1 has been prepared to help the reviewer understand how the checklists in this Annex may be used. There is no Code requirement for a checklist. However, Code users and reviewers must make certain that every variable as specified in QW-250, by process is addressed. One method is to use the QW-250 list of variables for the process. This method is flawed in that the supplementary essential variables may distract the Code user and/or the reviewer and there are other Code requirements which are not on the QW-250 lists.

Figure C.3 is a sample checklist, which has been prepared to demonstrate how a reviewer can use the checklists in this chapter to evaluate the Company Inc. WPS CS-1 and PQR CS-1. The following text will identify a marker, a number in a circle such as ① which may be found on the sample WPS CS-1 (Figure C.1), on the sample PQR (Figure C.2), and again on the sample SMAW Checklist (Figure C.4) for Company Inc. The circled number is then described in C.4 to explain each of these entries. This circled marker number may occur in more than one place, as necessary, to locate where a given variable or entry may be found. Each reviewer may use these checklists in any manner to suit their needs.

#### C.3 Checklist for WPS and PQR

Figure C.3 is a detailed checklist to document that the WPS and PQR have complied with all of the requirements of Section IX and the applicable Construction Code. This checklist may be used by the Code user, the Authorized Inspector, the review team, or any interested party.

The checklist provides a convenience and may be used or revised in any manner that helps the reviewer. Or the checklist may not be required at all. You may have noticed that commercial airline pilots go through a checklist prior to every flight. It is no less important to use a checklist when reviewing documents intended for pressure containing items. The authors have found that using a checklist has helped where some details might otherwise be missed. Code review team members have reported that checklists are invaluable for their audits and reviews.

Figure C.3 is derived from the actual list of variables required for the SMAW process in paragraph QW-253 of Section IX. The checklist has been prepared for welding applications where *notch-toughness is not a requirement* of the construction code and therefore the supplementary essential variables are not required, and are not listed on this checklist. These checklists may be used when notch toughness applications are a requirement of the construction code by adding the supplementary essential variables from QW-253 for the applicable process.

Each checklist has three additional columns: WPS, PQR, and QUAL.

- 1) The WPS column is used to document that the WPS has been properly completed and values have been specified for all the requirements of Section IX and the construction code.
- 2) The PQR column is used to document that the PQR has been properly completed and values have been recorded for all of the requirements of Section IX and the construction code.
- 3) The QUAL column is used to document that the values for each essential variable recorded on the PQR properly support the specified range of variables on the WPS.

The checklist begins with the identification block, which allows the Code user to list the WPS and supporting PQR, revision level, and date of the reviewed documents. The checklist ends with a Documentation Review Certification that allows space for additional comments, and a space to sign and date the review and indicate whom the reviewer is representing. Although these details are optional, they provide verifiable, documented evidence of the review of these documents.

The first five columns of Figure C.3 are similar to QW-253 (with the exception of the supplementary column). The next three columns are titled WPS, PQR, and QUAL. The variables are listed as NE, for nonessential variables, or E for essential variables. Additional considerations for completing these columns include:

- a) The WPS column spaces are all open, since the Code user must specify a range for all essential and nonessential variables (see QW-200.1(b) of Section IX) on the WPS.
- b) The PQR column spaces are only open opposite the essential variables, because the Code user need only record the values used for all essential variables on the PQR. The spaces opposite the nonessential variables are shaded, because the Code user is not required to document nonessential variables on the PQR.
- c) The QUAL column spaces are open opposite the essential variables, because the QUAL column will record if the essential variables specified on the WPS are properly supported by the value recorded on the PQR. The spaces opposite the nonessential variables are shaded, as the QUAL column does not evaluate the qualification of nonessential variables.

When each space under the WPS and PQR columns has proper entries, the reviewer may conclude that the WPS and PQR are properly prepared. If either the WPS or PQR are not properly prepared, or if one or more variables are not described or recorded, then the documents must be properly completed for each errant variable. When every variable in both columns is acceptable (properly addressed), and each space in the QUAL column is noted OK (or a 😊), the reviewer has a verifiable, documented record of the review.

The nonessential variables must be evaluated against the details defined in QW-402 through QW-410. The reviewer may list "All" in the space opposite QW-405.1 under the WPS space, or simply note "OK" (or a 😊), in that same space. The preferred entry is a value that will provide the most information for future reference. The reviewer may check the type of electrodes that have been specified, conclude that both electrodes may be used in all positions, and therefore accept all positions on the WPS for this variable.

Verifying some of the entries may be difficult. For example, QW-402.4 and QW-402.11 may both be covered by a single entry such as "no backing." QW-403.7 and QW-403.8 both address base metal thickness. A single entry in the WPS column, such as  $1/16$  in. (1.5 mm) through  $3/4$  in. (19 mm) can cover both variables, or the reviewer could note opposite QW-403.7 that the variable was not applicable for this application, since QW-403.7 only applies when the PQR test coupon thickness is  $1/2$  in. (38 mm) or greater.

QW-403.11 and QW-403.13 may also be satisfied with a single entry, such as P-Number 1 to P-Number 1, or the reviewer could note that QW-403.13 is not applicable since it only applies to welding procedure specifications using P-Numbers 5, 9, or 10 base metals.

**QW-482 SUGGESTED FORMAT FOR WELDING PROCEDURE SPECIFICATIONS (WPS)**  
 (See QW-200.1, Section IX, ASME Boiler and Pressure Vessel Code)

Company Name: Company Inc. By: Pea Green  
 Welding Procedure Specification No.: CS-1 Date: 01Aug87 Supporting PQR No.(s): CS-1  
 Revision No. \_\_\_\_\_ Date: \_\_\_\_\_  
 Welding Process(es): GMAW 28 Type(s): Manual 26  
(Automatic, Manual, Machine, or Semi-Auto)

**JOINTS (QW-402)** Details 3

Joint Design: Single V, double V, J & U 1  
 Backing (Yes):  2 (No):  2  
 Backing Material (Type): weld metal 2  
(Refer to both backing and retainers.)

Metal 4  Nonfusing Metal  
 Nonmetallic  Other

Sketches, Production Drawings, Weld Symbols or Written Description should show the general arrangement of the parts to be welded. Where applicable, the root spacing and the details of weld groove may be specified.

(At the option of the Mfr., sketches may be attached to illustrate joint design, weld layers and bead sequence, e.g. for notch toughness procedures, for multiple process procedures, etc.)

---

**\*BASE METALS (QW-403)**

P.No.: 1 8 9 Group No.: \_\_\_\_\_ to P.No.: 1 8 9 Group No.: \_\_\_\_\_  
 OR  
 Specification type and grade: \_\_\_\_\_  
 to Specification type and grade: \_\_\_\_\_  
 OR  
 Chem. Analysis and Mech. Prop.: \_\_\_\_\_  
 to Chem. Analysis and Mech. Prop.: \_\_\_\_\_  
 Thickness Range \_\_\_\_\_

Base Metal: \_\_\_\_\_ Groove: 1/8 in. through 3/4 in. 5 6 29 Fillet: \_\_\_\_\_  
 Pipe Dia. Range: \_\_\_\_\_ Groove: 1 in. min. OD Fillet: \_\_\_\_\_  
 Other: 7 30 31 32

---

**\*FILLER METALS (QW-404)**

Spec. No. (SFA): 5.1 14  
 AWS No. (Class): E7018 14  
 F.No.: 5 10  
 A.No.: 2 11  
 Size of Filler Metals: 3/16, 1/4, 5/16 in. 12

Weld Metal  
 Thickness Range \_\_\_\_\_  
 Groove: 3/4 in. max. 13  
 Fillet: \_\_\_\_\_

Electrode-Flux (Class): \_\_\_\_\_  
 Flux Trade Name: \_\_\_\_\_  
 Consumable Insert: \_\_\_\_\_  
 Other: \_\_\_\_\_

\*Each base metal-filler metal combination should be recorded individually.

Figure C.1a—Sample WPS #CS-1, Page 1 of 2



**QW-482 (Back)**

WPS No.: \_\_\_\_\_ Rev.: \_\_\_\_\_

---

**POSITIONS (QW-405)** **POSTWELD HEAT TREATMENT (QW-407)**

Position(s) of Groove: All 15 Temperature Range: NA 19 20

Welding Progression: Up: X 16 Down: X 16 Time Range: \_\_\_\_\_

Position(s) of Fillet: \_\_\_\_\_

---

**PREHEAT (QW-406)** **GAS (QW-408)**

Preheat Temp. Min.: 50°F min 17 Percent Composition

Interpass Temp. Max.: \_\_\_\_\_ Gas(es) (Mixture) Flow Rate

Preheat Maintenance: 18 Shielding: \_\_\_\_\_

(Continuous or special heating where applicable should be recorded) Trailing: \_\_\_\_\_

Backing: \_\_\_\_\_

---

**ELECTRICAL CHARACTERISTICS (QW-409)**

Current AC or DC: DC 21 Polarity: E<sub>ov</sub> 21

Amps (Range): see below 22 Volts (Range): 22

(Amps and volt range should be recorded for each electrode size, position, and thickness, etc. This information may be listed in a tabular form similar to that shown below.)

Tungsten Electrode Size and Type: \_\_\_\_\_ (Pure Tungsten, 2% Thoriated, etc.)

Mode of Metal Transfer for GMAW: \_\_\_\_\_ (Spray arc, short circuiting arc, etc.)

Electrode Wire feed speed range: \_\_\_\_\_

---

**TECHNIQUE (QW-410)**

String or Weave Bead: string or weave 23

Orifice or Gas Cup Size: \_\_\_\_\_

Initial and Interpass Cleaning (Brushing, Grinding, etc.): 24

Method of Back Gouging: air-arc or grinding 25

Oscillation: \_\_\_\_\_

Contact Tube to Work Distance: \_\_\_\_\_

Multiple or Single Pass (per side): 60

Multiple or Single Electrodes: \_\_\_\_\_

Travel speed (Range): \_\_\_\_\_

Peening: 27

Other: \_\_\_\_\_

---

Weld Layer(s)	Process	Filler Metal		Current		Volt Range	Travel Speed Range	Other <small>(e.g., Remarks, Comments, Hot Wire Addition, Technique, Torch Angle, Etc.)</small>
		Class	Dia.	Type Polar.	Amp. Range			
Root	SMAW	E7010	3/32"	DC RP	60-120			
Fill	"	"	1/8"	"	95-150			
			3/32"	"	125-175			
			12	21	22			

Figure C.1b—Sample WPS #CS-1, Page 2 of 2

**QW-483 SUGGESTED FORMAT FOR PROCEDURE QUALIFICATION RECORDS (PQR)**  
 (See QW-200.2, Section IX, ASME Boiler and Pressure Vessel Code)  
 Record Actual Conditions Used to Weld Test Coupon.

Company Name: Company Inc.  
 Procedure Qualification Record No.: CS-1 Date: 07Aug87  
 WPS No.: 58  
 Welding Process(es): GMAW 43  
 Types (Manual, Automatic, Semi-Auto.): Manual

---

JOINTS (QW-402): 44

Groove Design of Test Coupon  
 (For combination qualifications, the weld metal thickness shall be recorded for each filler metal or process used.)

<p><b>BASE METALS (QW-403)</b>                  Material Spec.: <u>SA-535</u>                  Type or Grade: <u>PH</u>                  P-No.: <u>4</u> <u>35</u> <u>36</u> to P-No.: <u>4</u> <u>35</u> <u>36</u>                  Thickness of Test Coupon: <u>3/16 in.</u> <u>33</u> <u>34</u> <u>39</u>                  Diameter of Test Coupon: <u>6 in.</u>                  Other: <u>34</u> <u>45</u></p>	<p><b>POSTWELD HEAT TREATMENT (QW-407)</b>                  Temperature: <u>1150°F ± 50°F</u> <u>41</u>                  Time: <u>25 minutes</u>                  Other: <u>below the lower transformation temperature</u> <u>42</u></p>																
<p><b>FILLER METALS (QW-404)</b>                  SFA Specification: <u>E51</u>                  AWS Classification: <u>E7018</u>                  Filler Metal F.No.: <u>4</u> <u>37</u>                  Weld Metal Analysis A.No.: <u>2</u> <u>38</u>                  Size of Filler Metal: _____                  Other: _____                  Weld Metal Thickness: <u>39</u></p>	<p><b>GAS (QW-408)</b></p> <table style="width: 100%; border-collapse: collapse;"> <thead> <tr> <th style="width: 30%;"></th> <th style="width: 30%;">Gas(es)</th> <th style="width: 20%;">Percent Composition (Mixture)</th> <th style="width: 20%;">Flow Rate</th> </tr> </thead> <tbody> <tr> <td>Shielding:</td> <td>_____</td> <td>_____</td> <td>_____</td> </tr> <tr> <td>Trailing:</td> <td>_____</td> <td>_____</td> <td>_____</td> </tr> <tr> <td>Backing:</td> <td>_____</td> <td>_____</td> <td>_____</td> </tr> </tbody> </table> <p><b>ELECTRICAL CHARACTERISTICS (QW-409)</b>                  Current: _____                  Polarity: _____                  Amps: _____ Volts: _____                  Tungsten Electrode Size: _____                  Other: _____</p>		Gas(es)	Percent Composition (Mixture)	Flow Rate	Shielding:	_____	_____	_____	Trailing:	_____	_____	_____	Backing:	_____	_____	_____
	Gas(es)	Percent Composition (Mixture)	Flow Rate														
Shielding:	_____	_____	_____														
Trailing:	_____	_____	_____														
Backing:	_____	_____	_____														
<p><b>POSITION (QW-405)</b>                  Position of Groove: <u>Flat</u>                  Weld Progression(Uphill, Downhill): _____                  Other: _____</p>	<p><b>TECHNIQUE (QW-410)</b>                  Travel Speed: _____                  String or Weave Bead: _____                  Oscillation: _____                  Multipass or Single Pass (per side): _____                  Single or Multiple Electrodes: _____                  Other: _____</p>																
<p><b>PREHEAT (QW-406)</b>                  Preheat Temp.: <u>200°F</u> <u>40</u>                  Interpass Temp.: _____                  Other: _____</p>																	

Figure C.2a—Sample PQR #CS-1, Page 1 of 2

QW-483 (Back)

PQR No. \_\_\_\_\_

46 Tensile Test (QW-150)

Specimen No.	Width	Thickness	Area	Ultimate Total Load Lb	Ultimate Unit Stress psi	Type of Failure & Location
1	0.750	0.750	0.5775	40880	72025	
2	0.710	0.750	0.5625	40110	74650	
					47	59

48 Guided-Bend Tests (QW-160)

Type and Figure No.	49 Result
Side Bend QW-462.2	No defects
Side Bend QW-462.2	one 7/16 in. opening

Toughness Tests (QW-170)

Specimen No.	Notch Location	Specimen Size	Test Temp.	Impact Values			Drop Weight Break (Y/N)
				Ft-lb	% Shear	Mils	

Comments: \_\_\_\_\_

Fillet-Weld Test (QW-180)

Result Satisfactory: Yes: \_\_\_\_\_ No: \_\_\_\_\_ Penetration into Parent Metal: Yes: \_\_\_\_\_ No: \_\_\_\_\_

Macro Results: \_\_\_\_\_

Other Tests

Type of Test: 50  
 Deposit Analysis: 50  
 Other: 52 53 54

Welder's Name: Perrine Nau Clock No.: 002E Stamp No.: FN  
 Tests conducted by: Pea Green Laboratory Test No.: \_\_\_\_\_

We certify that the statements in this record are correct and that the test welds were prepared, welded, and tested in accordance with the requirements of Section IX of the ASME Code.

Manufacturer: Company Inc.

Date: 01 Aug 87 By: Pea Green 55

(Detail of record of tests and illustrations only and may be modified to conform to the type and number of tests required by the Code.)

Figure C.2b—Sample PQR #CS-1, Page 2 of 2

Review of WPS #		Revision #			Dated:	
Supporting PQR(s) #		Revision #			Dated:	
Paragraph	Brief of Variables	Ess	Non	WPS	PQR	QUAL
QW-402 Joints	.1	φ Groove design		NE		
	.4	- Backing		NE		
	.10	φ Root spacing		NE		
	.11	± Retainers		NE		
QW-403 Base Metals	.7	T/t limits > 8 inch (200 mm)	E			
	.8	φ T qualified	E			
	.9	t Pass > ½ in. (13 mm)	E			
	.11	φ P-No. qualified	E			
	.13	φ P-No. 5/9/10	E			
QW-404 Filler Metals	.4	φ F-Number	E			
	.5	φ A-Number	E			
	.6	φ Diameter		NE		
	.30	φ t	E			
	.33	φ AWS class		NE		
QW-405 Positions	.1	+ Position		NE		
	.3	φ ↑↓ Vertical welding		NE		
QW-406 Preheat	.1	decrease > 100°F (Δ56°F)	E			
	.2	φ Preheat maintenance		NE		
QW-407 PWHT	.1	φ PWHT	E			
	.4	T limits	E			
QW-409 Electric	.4	φ Current or polarity		NE		
	.8	φ I & E range		NE		
QW-410 Tech	.1	φ String/Weave		NE		
	.5	φ Method cleaning		NE		
	.6	φ Method back gouge		NE		
	.9	φ Multi to single pass/side				
	.25	φ Manual or automatic		NE		
	.26	± Peening		NE		

*CASTI Guidebook to ASME Section IX—Welding Qualifications*

**Figure C.3a—Shielded Metal-Arc Welding (SMAW) Checklist, Page 1 of 2**

The checklist covers some requirements that are not variables. One such requirement is QW-401, which clearly states that each essential variable has been listed in QW-250 for each specific process. The paragraph ends by stating, “A change in a process is an essential variable change.” As such, these checklists provide a space to document the type of process.

QW-202.2 has some special rules for fillet welds and partial penetration groove welds, so it is important to document that all these rules have been properly applied to the WPS and PQR. This is a good reminder to document the rules of QW-202.2, QW-202.3, and QW-202.4.

QW-200.4 has some special requirements for combination WPSs. Section IX has referred to a change in a “procedure” (non-standard term) as any change in an essential variable. This is a good reminder to document the rules of QW-200.4 if the Code user has a combination procedure (WPS).

QW-451.1 reminds the Code user to document the proper number of bend and tension tests, and there is a space to record the results.

Review of WPS #		Revision #	Dated:		
Supporting PQR(s) #		Revision #	Dated:		
Paragraph	Brief of Variable	Description	WPS	PQR	QUAL
QW-401	Process				
QW-202.2	Groove and Fillet				
QW-202.3	Repairs buildup				
QW-202.4	Dissimilar base T <sub>b</sub>				
QW-200.4	Combined procedures				
Requirement		Description	PQR		
QW-451.1	Bend tests	Four bend tests per QW-160			
Results					
QW-451.1	Tension tests	Two tension tests per QW-150			
Results					
QW-404.5	A-Number	Basis for A-Number			
QW-170	Notch-toughness	Required by construction Code?			
Company requirements?					
Contract requirements?					
Other requirements?					
QW-201	Certification	Company representative and date.			
Documentation Review Certification					
Reviewer comments:					
These documents reviewed by:			Date:		
Reviewer representing:					

*CASII Guidebook to ASME Section IX—Welding Qualifications*

**Figure C.3b—Shielded Metal-Arc Welding (SMAW) Checklist, Page 2 of 2**

QW-404.5 reminds the Code user to document an important requirement, that is, the basis for assigning the A-Number on the two documents.

QW-170 reminds the Code user to document if notch-toughness was required by the construction code.

There is space to document any company, customer, or contractual requirements.

QW-201 reminds the Code user that a company representative must certify the PQR.

#### **C.4 Completed WPS and PQR Checklist**

Figure C.4 is a completed checklist, which has been prepared to demonstrate how a reviewer can use the checklists in Figure C.3 to evaluate the Company Inc. WPS CS-1 and PQR CS-1. The following text will identify a marker, a number in a circle such as ①, which may be found on the completed SMAW Checklist for Company Inc. Section C.4 is a narrative that contains explanations for each marker shown in Figure C.2. This circled marker number may occur in more than one place, as necessary, to locate where a given variable or entry may be found. Each reviewer may use these checklists in any manner to suit their needs.

When the reviewer has verified that both documents are properly prepared, the checklist may be used to document if each essential variable recorded on the PQR supports the range specified on the WPS.



Figure C.1 (WPS CS-1) and Figure C.2 (PQR CS-1) are sample forms QW-482 and QW-483 respectively found in ASME Section IX, non-mandatory Annex B. These forms are typical of limited information, typed into the proper space on the forms and are intended to provide examples typical of the documentation reviewers are likely to encounter.

A Code user may also review the WPS CS-1 or PQR CS-1 for a specific entry, for example, PWHT on WPS CS-1. The Code user would find PWHT on WPS CS-1 (page 2) and markers 19, 20 at that entry. The Code user may then find 19 and 20 on the checklist (Figure C.4) under the WPS column and find “NA 😞”, indicating that the entry on WPS CS-1, at the PWHT box, which was “NA,” may not be an appropriate entry as indicated by the “😞.” The Code user may then look for the markers 19, 20 in C.5 to review the explanation of how to handle that specific entry. This may help the Code user who may only need a few pointers in a specific area. This exercise is not intended, however, to encourage the Code user to simply fill in the forms.

When the full checklist (Figure C.4) uses all the markers 1 through 60, the reviewer may discover something about the welding documentation. But equally important, the reviewer may see many blank areas on the WPS or PQR that have not been addressed. If it is not on the checklist, the variable or entry may apply to another process or application. For example, there are no electrical nor technique variables (QW-409 and QW-410, respectively) listed on the PQR. Did the checklist miss these variables? No, there are no essential variables for the SMAW process in either the QW-409 or QW-410 variables. But the sample forms in Section IX, Nonmandatory Annex B have spaces for all variables for four processes (specifically SMAW, GMAW, GTAW and SAW), which will result in blank spaces even when all the variables for a specific process have been addressed. The checklist can be used to assure the reviewer that the documentation under review has had every required variable addressed.

## C.5 Checklist Narrative

### C.5.1 General

A reviewer may start with the identification block at the top of both pages of Figure C.4 (completed SMAW checklist) to provide a record of the exact documentation being reviewed. A review of the values specified or recorded at each marker is discussed below.

The following notes are referenced to the marker (bracketed) numbers on the sample documentation of Figure C.1 and Figure C.2. These same marker numbers are referenced on the sample checklist for convenience in locating each area where the apparent non-conformity appeared in the WPS and PQR.

### C.5.2 WPS Audit Checklist

① On WPS CS-1 (Figure C.1), Company Inc. listed “Single V, double V, J & U” grooves to meet the requirements of QW-402.1. In Figure C.4, the reviewer listed V, X, J, and U as a key to what was on the WPS. QW-402.1 deals with type of joint and, in the reviewer’s opinion, this entry addressed the groove design as required by QW-402.1. The reviewer also believed the entry was proper and adequate. The reviewer then affixed a 😊, indicating that an entry had been made which addressed QW-402.1, and that the entry was do-able, and conformed to the requirements of the Code.

② The subject of variable QW-402.4 is backing. The WPS specified “Yes and No,” which the reviewer accepted as addressing QW-402.4. The reviewer therefore noted “yes and no” in the WPS column and a 😊, indicating the variable had been addressed, and the entry was acceptable. The Code user specified, “weld metal” as the backing material (type). This is not a required entry, as the E6010 is obviously the backing for the subsequent E7018 layers. But it is always acceptable, and often prudent to add information beyond that required by the Code.

③ The reviewer could not find an entry that addressed QW-402.10, so therefore noted “not specified” in the WPS column and a 😞, indicating the WPS is not complete. A range of root spacing must be specified on the WPS in order to properly complete the WPS.

Review of WPS # Company Inc. CS-1				Revision # -0-		Dated: 01 Aug87			
Supporting PQR(s) # CS-1				Revision # -0-		Dated: 01 Aug87			
Paragraph	Brief of Variables	Ess	Non	WPS		PQR	Qual		
QW-402 Joints	.1	φ Groove design		NE	①	V, X, J, & U ☺			
	.4	- Backing		NE	②	Yes & No ☺			
	.10	φ Root spacing		NE	③	Not specified ☹			
	.11	± Retainers		NE	④	☐ Not v ☺			
QW-403 Base Metals	.7	T/t limits > 8 in.	E		⑤	Not applicable			
	.8	φ T qualified	E		⑥	1/16-3/4 in. ☺	③③	3/8 in. ☺	☺
	.9	t pass > 1/2 in.	E		⑦	Not specified ☹	③④	<1/2 in. ☺	☹
	.11	φ P-No. qualified	E		⑧	P-No. 1 to P-No. 1 ☺	③⑤	P-No. 4 ☺	☹
.13	φ P-No. 5/9/10	E		⑨	Not applicable	③⑥			
QW-404 Filler Metals	.4	φ F-Number	E		⑩	F-No. 3 ☺	③⑦	F-No. 4 ☺	☹
	.5	φ A-Number	E		⑪	A-No. 2 ☺/☹/?	③⑧	A-No. 2 ☺/☹	?
	.6	φ Diameter		NE	⑫	3/32 - 5/32 in. ☺			
	.30	φ t	E		⑬	3/4 in. max. ☺	③⑨	3/8 in. ☺	☺/☹
	.33	φ AWS class		NE	⑭	A5.1 E7010 ☺/☹			
QW-405 Positions	.1	+ Position		NE	⑮	All ☺			
	.3	φ ↑↓ Vertical welds		NE	⑯	Up or Down ☺			
QW-406 Preheat	.1	Decrease > 100°F	E		⑰	50°F min. ☺	④①	200°F ☺	☹
	.2	φ Preheat maint.		NE	⑱	Not specified ☹			
QW-407 PWHT	.1	φ PWHT	E		⑲	NA ☹	④②	1150°F ☺	☹
	.4	T limits	E		⑳	NA ☹	④③	☹	☺/☹
QW-409 Electric	.4	φ Current or polarity		NE	㉑	DC rev. ☺			
	.8	φ I & E range		NE	㉒	Amp range ☺			
QW-410 Tech.	.1	String/Weave		NE	㉓	String/weave ☺			
	.5	φ Method cleaning		NE	㉔	Not specified ☹			
	.6	φ Method back gouge		NE	㉕	Arc/grind ☺			
	.9	φ Multiple to single pass per side		NE	⑥①	Not specified ☹			
	.25	φ Manual/automatic		NE	㉖	Manual ☺			
.26	± Peening		NE	㉗	Not specified ☹				

CASTI Guidebook to ASME IX-Welding Qualifications

Figure C.4a—Example of Completed Shielded Metal-Arc Welding (SMAW) Checklist, Page 1 of 2

④ The Nonmetallic and Nonfusing Metal boxes were not checked, indicating, that neither backing type has been specified.

NOTE Since neither backing type (retainer) was specified, neither nonmetallic nor nonfusing backing types (retainers) may be used unless the WPS is revised to include one or more of these backing types. This entry in the WPS column received a ☹ of approval.

⑤ The reviewer read QW-403.7 and found this variable applied only when the PQR test coupon was 1 1/2 in. (38 mm) thick or thicker. A quick check of PQR CS-1 revealed a 3/8 in. (10 mm) PQR test coupon was used, and therefore QW-403.7 was not applicable for these documents. The reviewer noted not applicable in the WPS column and crosshatched the spaces under PQR & QUAL on that line, since the variable was not applicable.

Review of WPS # Company Inc. CS-1		Revision # -0-		Dated: 01Aug87	
Supporting PQR(s) # CS-1		Revision # -0-		Dated: 01Aug87	
Paragraph	Brief of Variable	Description	WPS	PQR	QUAL
QW-401	(28) Process	SMAW	√ ☺	(43) √ ☺	☺
QW-202.2	(29) Groove and Fillet	Groove welds	√ ☺	(44) ? ☺	☺
QW-202.3	(30) Repairs Buildup	Not specified		(45) ☺	☺
QW-202.4	(31) Dissimilar Base T <sub>b</sub>	Not applicable		(45) ☺	☺
QW-200.4	(32) Combination procedures	QW-200.4(a) provisions only		(45) ☺	☺
Requirement		Description		PQR	
QW451.1	Bend Tests	Four bend tests per QW-160	(46)	2 side bends ☺	
	Results	One clear, one with 3/32 in. opening ☺	(47)	Results ☺/☺	
QW-451.1	Tension Tests	Two tension tests per QW-150	(48)	2 tension tests ☺/☺	
	Results	72,325 psi, 74,650 psi ☺	(49)	Need 60 ksi ☺	
QW-404.5	A-Number	Basis for A-No.?	(50)	?	
QW-170	Notch-Toughness	Required by construction Code?	(51)	Not required.	
	Company requirements?	No Company requirements.	(52)		
	Contract requirements?	No Contract requirements.	(53)		
	Other requirements?	No Other requirements.	(54)		
QW-201	Certification	Company representative & date.	(55)	Pea green ☺	
Documentation Review Certification					
Reviewer comments:					
WPS incomplete. Cannot evaluate until markers (3), (7), (18), (19), (20), (24), (27) & (60) have been completed and (14) has been corrected.					
PQR incomplete. Cannot evaluate until: marker (46) has recorded four bends, marker (48) has the test coupon mystery solved & marker (38) has been corrected.					
When the problems with the WPS and PQR noted in the comments above have been resolved, the following PQR variables do not support the WPS specified ranges as detailed below:					
Marker (35) P-No. 4, does not support the value specified at marker (8) P-No. 1.					
Marker (37) F-No. 4, does not support the value specified at marker (10) P-No. 3.					
Marker (39) 200°F (95°C), does not support the value specified at marker (17) 50°F (10°C).					
Marker (40) 1150°F (595°C) PWHT, does not support the value specified at marker (19), no PWHT.					
These documents reviewed by: Per MacSquinty (56)				Date: 01Aug87	
Reviewer representing: Company Inc. (57)					

Figure C.4b—Example of Completed Shielded Metal-Arc Welding (SMAW) Checklist, Page 2 of 2



- ⑥ The reviewer noted  $1/16$  in. to  $3/4$  in. (1.5 mm to 19 mm) in the WPS column and a 😊 of approval.
- ⑦ The reviewer noted the thickness of each pass was “not specified 😞.” QW-403.9 must be specified to bring WPS CS-1 into conformance with Section IX.

NOTE The reviewer should continue through each variable on the list, regardless if it is an essential or a nonessential variable, simply reviewing the subject of each variable and making certain an appropriate value for each variable was recorded on the WPS. It will be after the WPS and the PQR are both validated as complete, that the PQR will then be evaluated to determine if the values specified on the WPS are supported by the values recorded on the PQR.

- ⑧ P-No. 1 to P-No. 1. 😊 This is an acceptable entry for the P-Number.
- ⑨ Not applicable. Marker ⑧ indicates this WPS covers P-No. 1 and, therefore, QW-403.13, which only deals with P-Numbers 5, 9, and 10, is not applicable. The reviewer so noted “Not applicable” in the WPS column and crosshatched the spaces under PQR & QUAL on that line.
- ⑩ F-Number 3. 😊 This is an acceptable entry for the F-Number.
- ⑪ A-Number 2 😊 / 😞. The Code user specified an A-Number 2 analysis. This entry gets a 😊, because the Code user specified an A-Number analysis on the WPS, which meets the requirements of QW-404.5. The 😞 ⑪, however, is caused by the fact that the reviewer cannot assess the A-Number of the E7010, since there is no such AWS classification as detailed in marker ⑭. Without a classification, and with no other basis for the A-Number documented, it is not possible to establish an A-Number 2 analysis.
- ⑫  $3/32$  in. to  $5/32$  in. (2.5 mm to 4 mm) 😊. This is an acceptable entry for the filler metal diameters.
- ⑬  $3/4$  in. (19 mm) max. 😊. This is an acceptable entry for the maximum weld metal thickness.
- ⑭ A5.1 E7010 😊 / 😞. The WPS specified an ASME SFA-5.1 specification, AWS E7010 classification, which meets the requirement of QW-404.33 for specifying the electrode classification.
- NOTE The entry at ⑭, however, has two errors in that ASME SFA-5.1 does not have an E7010 classification. ASME SFA-5.5 does cover the E70XX class of filler metals, but in this example, the E7010 is not an AWS classification without the full mandatory classification designator of -A1. The proper description is AWS Specification A5.5, AWS Classification E7010-A1.
- ⑮ All 😊. This is an acceptable entry, indicating the WPS is acceptable for “all” positions.
- ⑯ Up and down were both checked 😊. This is an acceptable entry, indicating the WPS is acceptable for both the upward and downward progressions when welding in the vertical positions.
- ⑰ 50 °F (10 °C) minimum 😊. This is an acceptable entry for the minimum preheat.
- ⑱ Not Specified 😞.
- ⑲ and ⑳ NA 😞. There are times when NA is appropriate, as in markers ⑧ and ⑨. But there are times when NA is not acceptable. In the instance of QW-407.1, an essential variable, the Code requires the WPS to specify which of the conditions of PWHT are acceptable for use with the WPS. To indicate NA for an essential variable is a red flag for inspection authorities. Most of the time the Code user intends the NA to indicate that the WPS is not qualified for use with a PWHT applied. When a Code user has used NA on a series of WPSs intending it to mean “Not Applied” or “none applied,” the Code user may add a note indicating that when NA is noted in the PWHT space, it is intended to mean “Not Applied.” This may be a better choice than revising a series of WPSs and PQRs.
- ㉑ DC reverse 😊. This is an acceptable entry for the type of current (DC), and polarity (reverse) used.

22. An amperage range is specified in the WPS for each electrode diameter. 😊 Code user's may specify a large range of amperage to cover a large number of filler metal diameters. An Inspection Authority may ask the Code user to demonstrate the full range of amperage listed on the WPS for the smallest filler metal diameter specified. This demonstration may require a revision to the amperage range for each filler metal size.

23. String/Weave 😊. It is acceptable for normal applications to specify either string bead or weave bead or both.

24. Not specified 😊. In addition to Section IX, ASME Section VIII has rules for cleaning (UW-32). What better way than to specify the construction code rules on the WPS.

25. Air-arc and/or grind 😊. It is acceptable for normal applications to allow either, or both.

60. Not specified 😊. QW-410.9 was originally assigned as a nonessential variable then was removed for a period of time. The 2001 Edition of Section IX reassigned QW-410.9 as a nonessential variable. The checklist has added a space to verify that this variable has been addressed on the WPS. That is why the numbering system is out of order.

NOTE 1 This example of a nonessential variable being removed from Section IX, and then returned, is a strong reason why a Code user should review all changes to Section IX as they are published. We strongly recommend that all documentation be updated to meet all changes to Section IX. It is easy to say, "Changes are not required to be amended as noted in QW-100.3." However, future problems may well be mitigated when these documents are amended to meet new requirements as they are published.

NOTE 2 QW-410.9 was also added as a supplementary essential variable.

26. Manual 😊. Specified on page 1 of WPS CS-1.

27. Not specified 😊. Section IX requires the addition or deletion of peening to be specified on the WPS.

NOTE In addition to Section IX, ASME Section VIII has rules for peening (UW-39) which has some technical considerations, including PWHT considerations. Section VIII, UW-39, does not permit peening on the first or last pass unless the weld will be subjected to a PWHT. This sample WPS should restrict peening on the first or last pass, if the welding application is to be used on a Section VIII Code Stamped item.

28. ✓ 😊 The ✓ in the WPS column, page 2 of 2 indicates that a welding process was specified, as required by QW-401, which states, in part, that a change in process is an essential variable. The reviewer also inserted a 😊, indicating that the process specified was proper.

29. ✓ 😊 In the WPS column, page 2 of 2 (QW-403, page 1 of WPS #CS-1) indicates the rules of QW-202.2(a) have been met in that the WPS specified groove welds.

NOTE The WPS did not indicate anything for fillet welds. A groove welded PQR supports all fillet welds, but the WPS must specify it is applicable for fillet welds.

30. QW-202.3 allows repairs and buildup, but there was no special mention of such on the WPS. This does not mean that the WPS may not be used for repairs and buildup, but rather that no special provisions were made for QW-202.3; hence, the crosshatch in the WPS column indicating no comment.

31. QW-202.4 has special allowances for dissimilar base metal thicknesses, but this WPS is not eligible for any of those special provisions; hence, the crosshatch indicating not applicable in the WPS column.

32. QW-200.4 has special rules for combination of procedures. In the description column, the reviewer noted that this WPS could take advantage of QW-200.4(a), but not QW-200.4(b).

The reviewer notes on the bottom of page 2 of 2 of the checklist that there are several items that must be resolved before WPS CS-1 may be accepted. For the purpose of this guide, however, the reviewer will now begin the review of PQR CS-1.

### C.5.3 PQR Audit Checklist

33  $\frac{3}{8}$  in. (10 mm) 😊. Indicates the thickness of the base metal test coupon  $T_c$  has been recorded on PQR CS-1 (Figure C-2). It is tempting at this point to begin comparing the PQR to the WPS, but this is not the time. The reviewer should verify that the PQR has properly addressed each essential variable, before determining if some parts of the PQR support some parts of the WPS. In the end, there is so much interaction between the variables, that both documents must be properly and completely prepared before any comparison may be meaningfully conducted.

34  $< \frac{1}{2}$  in. (13 mm) 😊. QW-403.9 requires the PQR to note if any single passes were greater than  $\frac{1}{2}$  in. (13 mm) in weld metal thickness. When the PQR test coupon is only  $\frac{3}{8}$  in. (10 mm), it is obvious that no single pass was greater than  $\frac{1}{2}$  in. (13 mm), thus the  $< \frac{1}{2}$  in. (13 mm) gets a 😊. There is no need to note specifically the variable and that no passes  $> \frac{1}{2}$  in. (13 mm), until the PQR test coupon exceeds  $\frac{1}{2}$  in. (13 mm).

35 P-Number 4 😊. ASME SA-335, Grade P11 has been verified as a P-Number 4 base metal (QW/QB-422) and P-Number 4 was recorded per QW-403.11. The PQR test coupon (ASME SA-335, Grade P 11) is a P-Number 4, despite the confusing Grade P11 on the end of the specification. The ASTM A 335 Grade P11 designation identifies the base metal as a  $1\frac{1}{4}\text{Cr}-\frac{1}{2}\text{Mo}$  base metal, which has been assigned to the ASME Section IX, P-Number 4 base metal grouping.

**Caution—It is easy to confuse an ASTM Grade PXX number with the ASME P-Numbers. This example should remind the Code user to use full descriptions of all materials carefully.**

36 Not Applicable. (QW-403.13 covers P-Numbers 5, 9, and 10 only). The reviewer crosshatched the spaces under PQR & QUAL on that line, since the variable was not applicable.

37 F-Number 4 😊. This is an acceptable entry for the filler metal F-Number used.

38 A-Number 2 😊 / 😊. The 😊 is because an A-Number was recorded. The 😊 is because the A-Number 2 is an error. The PQR listed an E7018 filler metal. Based on QW-442, in order to have an A-Number 2 analysis, the electrode must have a deposit with 0.4 % to 0.65 % Mo. In ASME SFA-5.1, AWS A5.1 E7018 must be produced with a guaranteed analysis of 0.30 % Mo. maximum, therefore, it is not possible for an E7018 classified filler metal to have an A-Number 2 analysis.

39  $\frac{3}{8}$  in. (10 mm) 😊. This is an acceptable method of recording the thickness of the test coupon for a single process PQR.

NOTE Filler Metals (QW-404) has a space specifically for weld metal thickness.

40 200 °F (95 °C) 😊. This is an acceptable method of recording the minimum preheat temperature applied on the PQR.

NOTE The WPS may specify an “increase” in preheat temperature that is much warmer than that which was recorded on the PQR. The “minimum” preheat, however, must be limited to a value not “less” than  $\Delta 100$  °F ( $\Delta 56$  °C).

41 1150 °F (620 °C)  $\pm 50$  °F ( $\Delta 28$  °C) 😊. This is an acceptable method of specifying the actual PWHT temperature used. QW-407.1(a)(2) specifies the condition; “PWHT below the lower transformation temperature.” This condition can be determined from the actual recorded condition of 1150 °F (620 °C)  $\pm 50$  °F ( $\Delta 28$  °C). The Code user must go beyond Section IX to evaluate the PWHT conditions of QW-407. There is no guidance in Section IX for determining these PWHT conditions

42 The PQR 😊 indicated the PWHT was conducted; “below the lower transformation temperature.” This gives the reviewer confidence that QW-407.4 has been addressed, since QW-407.4 only applies to applications when a PWHT has been applied; “above the upper transformation temperature.” Listing one of the actual PWHT conditions of QW-407.1 is an excellent method of addressing the PWHT essential variables.

- 43 ✓ 😊 The PQR listed the SMAW process in the ID block on page 1 of 2.
- 44 ? 😞 QW-202.2(a) requires a groove welded PQR test coupon to support full penetration groove welds, but PQR CS-1 did not indicate by sketch, symbol, or words if the test coupon was a groove butt weld, fillet weld, or other, therefore the “?”. However, a review of the tension test data would indicate that butt welded tensile specimens were tested, indicating that a groove welded PQR test coupon was used. The Code user should avoid the questions by describing the PQR test coupon in more detail, for an example, see sample PQR #Q134, by bill of material, sketch, and etc. 😊
- 45 A 😊 in the PQR column for 45 based on the assumption from that 44 a groove weld test coupon was used. The Code user should avoid such questions by indicating on the PQR that the test coupon was groove welded. See QW-202.3, QW-202.4, and QW-200.4 😊 😊 😊.
- 48 Two side bends 😞. QW-451.1 requires four bend test specimens for the qualification of a groove welded PQR test coupon. Therefore, this PQR is not properly qualified. 😞. If the test coupon is still properly identified, and there is sufficient material to perform the remaining two bend tests, then the Code user can process the additional two bend test specimens, completing this requirement of the PQR. (For the purpose of this example, we will assume this will be done, so we may proceed with the evaluation).
- 49 Results 😊 / 😞. The two bend specimen test results were acceptable 😊. One bend specimen had an opening of  $\frac{3}{32}$  in. (2.5 mm), which meets the requirements of QW-163. But there were only two bend specimens instead of the required four 😞. See marker 46.
- 46 😊 / 😞 Two transverse tension tests were conducted as required by QW-451 😊. The two tensile specimens measured approximately  $\frac{3}{4}$  in. (19 mm) by  $\frac{3}{4}$  in. (19 mm)! 😞 The PQR test specimen sizes should lead the reviewer to believe that there has been a mix-up. PQR CS-1 reported a test coupon base metal thickness ( $T_c$ ) of  $\frac{3}{8}$  in. (10 mm) 😞 PQR CS-1 reported a 6 in. (150 mm) diameter for ASME SA-335 (seamless pipe). An XX-Strong NPS 6 could be 0.864 in. (22 mm) nominal wall, which could have produced finished tensile specimens of  $\frac{3}{4}$  in. (19 mm) thickness. 😊 / 😞? What a mystery. Was there a mistake in reporting the thickness of the PQR test coupon, or was the mistake a mix up of test coupons? There are no redeeming clues or artifacts on the documentation available to resolve this mystery, but the PQR certainly is invalid until the mystery is resolved. 😞 These details will make an interesting entry on the non-conformity report. Code users should make certain they do not create mysteries when they “record” what happened during the welding and subsequent examination of a PQR test coupon.
- 47 😊 The PQR test coupon material, ASME SA-335 Grade P11, per QW/QB-422, has a minimum specified tensile strength of 60,000 psi [(60 ksi) 415 MPa]. The test results of 72,325 psi (499 MPa) and 74,650 psi (515 MPa) both exceed the 60,000 psi (415 MPa) minimum specified tensile strength required by QW-153.1(a).
- 50 ? There is no documentation as to how the A-No. 2 at marker 38 was selected. There are no Code rules that require documentation for the basis of determining the A-Number. The error noted at marker 38, however, supports our recommendation that a Code user should record the basis used to determine the A-Number. Errors may be prevented if a Code user makes an effort to record the basis for determining the A-Number. When a chemical analysis is taken of the PQR test coupon to verify the “A” number per QW-404.5(a), it would be reported on the deposit analysis line.
- 51 The note; “Not required,” at 51 indicates that the Notch-Toughness rules were reviewed, and were not a requirement of the code of construction.
- 52, 53, and 54 are all reminders to a reviewer that there may be other sources which may apply additional requirements beyond the Section IX rules. In this sample, there were no other requirements of company policy or contractual requirements.
- 55 😊 The PQR was certified by Pea Green, an apparent representative of Company Inc., as required by QW-201.

58 ☹️ There is a space on the WPS form to list the WPS which was followed when welding the PQR test coupon. There are no written rules in Section IX which mandate this requirement. There was no entry at marker 58, but this is a ☺️ since it is not a requirement to record the WPS that was followed. The entry is actually a holdover from previous editions of the Code that required the WPS to be recorded. The rule was removed, but the QW-483 form was not changed.

59 ☹️ There are no rules which require the Type of Failure & Location to be recorded on a PQR. This is a holdover from previous editions of the Code. However, there is one circumstance where the Code user would want to record the Location of the Failure. QW-153.1(d) has a special allowance for the circumstance when a tensile test specimen breaks in the base metal outside of the weld or fusion line. The test should be accepted as meeting the requirements, provided the strength is not more than 5 % below the minimum specified tensile strength of the base metal. It would be prudent for the Code user to record at least the location of the failure for the circumstance when the PQR failed below, but not more than 5 % below the specified tensile strength, and the break was in the base metal. This would document the evidence for the Code user to take advantage of the provisions of QW-153.1(d).

### C.5.4 PQR Supporting the WPS Qualification Audit

The reviewer has many comments on Figure C.4, page 2 of 2, at the reviewer comments line, noting items that must be resolved before PQR CS-1 may be accepted. For the purpose of this guide, however, the reviewer will now begin the review to document if the values recorded on PQR CS-1 (Figure C.2) adequately support the values specified on WPS CS-1 (Figure C.1).

In this exercise, the Code reviewer takes one variable at a time, evaluates the PQR value against the WPS value and notes, in the QUAL column, if the PQR supports the WPS ☺️ or does not support the WPS ☹️. The big picture must finally be reviewed to make certain the total range of variables is compatible. As we will see in this exercise, several PQR variables, on their own merit, do support the WPS variables. But taken as a whole, one may cancel out the other. For example, see the  $\frac{3}{8}$  in. (10 mm) thick PQR test coupon  $T_c$  at marker 33, which properly supports the  $\frac{1}{16}$  in. (1.5 mm) through  $\frac{3}{4}$  in. (19 mm) WPS base metal thickness  $T_b$  range 6. But the PQR test coupon at marker 35 was a P-Number 4 while the WPS base metal at marker 8 is a P-Number 1, which invalidates PQR CS-1, for the purpose of supporting WPS CS-1. We know this to be a fact of the Code, but for the purpose of this exercise, each variable will be evaluated on its own merit, with numerous examples of PQR CS-1 values that do not support the WPS CS-1 values, which will be noted in the Documentation Review Certification in Figure C.4, page 2 of 2.

5 ☹️ The first essential variable on the checklist, QW-403.7, was properly declared not applicable, and the space on that line under QUAL was crosshatched, and does not need further evaluation.

6 ☺️ and 33 ☺️. The PQR test coupon thickness (reported herein),  $T_c$  of  $\frac{3}{8}$  in. (10 mm), qualifies the WPS for a base metal thickness range  $T_b$  of  $\frac{1}{16}$  in. (1.5 mm) through  $\frac{3}{4}$  in. (19 mm) per QW-451.1. The QUAL column gets a ☺️ indicating the PQR value supports the WPS value, one on one. In the end, all other essential variables must also be compatible in order to gain full PQR support for a WPS.

7 ☹️ and 34 ☹️. The PQR single pass thickness (reported herein), was less than  $\frac{1}{2}$  in. (13 mm) [based on  $\frac{3}{8}$  in. (10 mm)  $T_c$ ], and therefore supports weld passes less than  $\frac{1}{2}$  in. (13 mm). We must list a ☹️ in the QUAL column, however, because the WPS did not specify if single passes are limited to less than  $\frac{1}{2}$  in. (13 mm), or if single passes may exceed  $\frac{1}{2}$  in. (13 mm). Specifying the single pass weld thickness range is important because, if WPS CS-1 is corrected to specify no single pass greater than  $\frac{1}{2}$  in. (13 mm) weld metal, then PQR CS-1 will support the  $\frac{1}{16}$  in. (1.5 mm) through  $\frac{3}{4}$  in. (19 mm) base metal thickness range  $T_b$ . However, if WPS CS-1 is corrected to specify that single weld passes may be greater than  $\frac{1}{2}$  in. (13 mm), then the WPS maximum base metal thickness range supported by the PQR is restricted to a range of 1.1 times the PQR test coupon thickness, or  $1.1 \times 0.375$  in. (9.5 mm) = 0.4125 in. (10.5 mm) maximum base metal thickness. QW-403.9 has a double edge sword. If the PQR records single passes greater than  $\frac{1}{2}$  in. (13 mm), the WPS base metal thickness range  $T_b$  is restricted to  $1.1 \times T_c$ . In the second example, as described herein, when the WPS specifies single weld passes greater than  $\frac{1}{2}$  in. (13 mm), the WPS must take a base metal thickness range  $T_b$  restriction of  $1.1(T_c)$ .



⑧ and ③⑤ The PQR value of P-Number 4, does not support the WPS value of P-Number 1. QW-424 allows a P-Number 4 PQR test coupon  $T_c$  to support a WPS for welding P-Number 4 to P-Number 4 and P-Number 4 to P-Number 1, but does not allow for the welding of P-Number 1 to P-Number 1. 😞

⑨ and ③⑥ QW-403.13 is not applicable since P-Numbers 5, 9, and 10 are not specified on either the WPS or the PQR. Therefore, this variable gets a 😊 indicating the variable has been reviewed.

⑩ and ③⑦ F-Number 4 does not support an F-Number 3 per QW-404.4. 😞 The F-Number 4 supporting the F-Number 3 filler metal frequently confuses Code users who may be thinking in terms of QW-433, which applies only to the qualification of a welder performance (WPQ).

⑪ and ③⑧ ? An A-Number 2 will support an A-Number 1 per QW-404.5. 😊 The WPS must be corrected, however, before any evaluation may be made. 😞 The PQR using the E7018, corrected to an A-Number 1 filler metal, would support the WPS using the corrected E7010-A1, for the A-Number variable, QW-404.5, second sentence, which states, "Qualification with an A-Number 1 will qualify for an A-Number 2 and vice versa." 😊

NOTE The Code user, however, must be aware of markers ⑩ and ③⑦, which does not allow the E7018 (F-Number 4) filler metal, to qualify for the E7010-A1 (F-Number 3), because of the F-Number variable QW-404.4.

⑬ and ③⑨ The  $\frac{3}{8}$  in. (10 mm) PQR test coupon  $t_c$  will support a WPS thickness range  $t_d$  of  $\frac{3}{4}$  in. (19 mm) maximum. 😊 However, the P-Number, F-Number, and other non-conformities will wipe the smile off that face when combined with the weld thickness  $t_d$ . 😞

⑰ and ④① The 200 °F (95 °C) preheat recorded on the PQR will not support the 50 °F (10 °C) preheat minimum, specified on the WPS. 😞 QW-406.1 allows a reduction in the preheat temperature of not more than  $\Delta 100$  °F ( $\Delta 56$  °C) from the preheat temperature recorded on the PQR. 😞 A new PQR is needed to support the 50 °F (10 °C) minimum preheat of the WPS, or the WPS must be revised or rewritten to specify a preheat of at least 100 °F (38 °C) minimum or warmer.

⑲ and ④② The PQR test coupon, which was subjected to a PWHT below the lower transformation temperature at 1150 °F (620 °C)  $\pm$  50 °F ( $\pm$  28 °C), will not support the WPS without PWHT. 😞 QW-407.1 requires a PQR without PWHT to support a WPS without a PWHT. Also, the preferred PWHT temperature is at least 1200 °F (required by ASME B31.3). 😞 The Code user may also revise WPS number CS-1 (Figure C-1) to indicate that the WPS is acceptable for use with a PWHT applied below the lower transformation temperature, which may be prudent, given the base metals involved.

⑳ and ④③ QW-407.4 is not applicable 😊, since it is for applications above the upper transformation temperature, where the PQR CS-1 stated "below the lower transformation temperature." 😊

㉓ and ④④ The SMAW process was used in the PQR and was specified in the WPS. 😊,

㉔ and ④⑤ Weld groove design is a nonessential variable per QW-402.1. But QW-202.2(a) requires groove welded PQRs to support the groove welds of the WPS. For the purpose of this example, assume that the tension test data of marker ④④ verified that the PQR test coupon was groove welded. Therefore there is a 😊 in the QUAL column because the groove welded PQR does support a groove welded WPS.

③① and ④⑥ The PQR will support the WPS if it specifies repairs or buildup. 😊 However the WPS must address QW-202.3 if it is to be used for repairs or buildup.

③② and ④⑦ The PQR will not support the WPS for dissimilar base metal thicknesses beyond the  $\frac{1}{16}$  in. (1.5 mm) through  $\frac{3}{4}$  in. (19 mm) range specified on the WPS. 😞 The dissimilar base metal thickness rule of QW-202.4 applies only when the PQR test coupon is  $1\frac{1}{2}$  in. (38 mm) thick, or thicker. 😊

NOTE The QW-202.4 rule may be applied for P-Number 8 and P-Number 41 through P-Number 47 PQR test coupons  $\frac{1}{4}$  in. (6 mm) thick and thicker.

32 and 45 The PQR will support the WPS for combination procedure WPSs, but only within the QW-200.4(a) range.  
☺ The QW-200.4(b) rule applies for carbon steel PQR test coupons  $\frac{1}{2}$  in. (13 mm) thick and thicker.

### C.5.5 Documentation Review Certification

The reviewer summarized all findings in the Documentation Review Certification Block, making notes for each non-conformity found, for future reference. There are just too many interdependent complications to try to remember the details of each non-conformity. The reviewer listed each item that had to be resolved on the WPS and PQR, and listed the essential variables recorded on the PQR that did not support the ranges specified on the WPS.

There were numerous blank spaces on PQR #CS-1 (Figure C.2) which were not addressed. Specifically, on page 1 of 2, WPS Number, Size of Filler Metal, Electrical Characteristics (QW-409), Interpass Temperature, Technique (QW-410) and other spaces were left blank. The rules of Section IX do not require these variables to be recorded on the PQR. However, any additional details added to the PQR may prove to be an invaluable resource for future use.

The reviewer should then certify the checklist, noting every non-conformity. The final space should specify who the reviewer is representing. This could be the jurisdiction, authorized inspection agency, insurance carrier, customer, Code user or etc.

## Annex D (normative)

### Guide To Common Filler Metal Selection

Tables D.1 and D.2 provide generally accepted electrode selections for the base materials shown. They do not attempt to include all possible choices. Welding consumables not shown for a particular combination of base materials should be approved by the purchaser.

**Table D.1—Common Welding Consumables for SMAW of Carbon and Low-alloy Steel**

Base Material <sup>1,2,4</sup>	Carbon Steel	Carbon-Molybdenum Steel	1&1 <sup>1</sup> / <sub>4</sub> CR- <sup>1</sup> / <sub>2</sub> MO Steel	2 <sup>1</sup> / <sub>4</sub> CR-1 Mo Steel	5CR- <sup>1</sup> / <sub>2</sub> Mo Steel	9Cr-1 Mo Steel	2 <sup>1</sup> / <sub>4</sub> Nickel Steel	3 <sup>1</sup> / <sub>2</sub> Nickel Steel	9 % Nickel Steel
Carbon Steel	AB <sup>3</sup>	AC	AD	AE	AF	AG	AJ	AK	*
Carbon-Molybdenum Steel		C	CD	CE	CF	CH	*	*	*
1&1 <sup>1</sup> / <sub>4</sub> CR- <sup>1</sup> / <sub>2</sub> MO Steel			D	DE	DF	DH	*	*	*
2 <sup>1</sup> / <sub>4</sub> CR-1 Mo Steel				E	EF	EH	*	*	*
5CR- <sup>1</sup> / <sub>2</sub> Mo Steel					F	FH	*	*	*
9Cr-1 Mo Steel						H	*	*	*
2 <sup>1</sup> / <sub>4</sub> Nickel Steel							J	JK	LM
3 <sup>1</sup> / <sub>2</sub> Nickel Steel								K	LM
9 % Nickel Steel									LM

\*An unlikely or unsuitable combination. Consult the purchaser if this combination is needed.

**Legend**

- A AWS A5.1 Classification E70XX low hydrogen<sup>5</sup>
- B AWS A5.1 Classification E6010 for root pass<sup>5</sup>
- C AWS A5.5 Classification E70XX-A1, low hydrogen
- D AWS A5.5 Classification E70XX-B2L or E80XX-B2, low hydrogen
- E AWS A5.5 Classification E80XX-B3L or E90XX-B3, low hydrogen
- F AWS A5.5 Classification E80XX-B6 or E80XX-B6L, low hydrogen
- G AWS A5.5 Classification E80XX-B7 or E80XX-B7L, low hydrogen
- H AWS A5.5 Classification E80XX-B8 or E80XX-B8L, low hydrogen
- J AWS A5.5 Classification E80XX-C1 or E70XX-C1L, low hydrogen
- K AWS A5.5 Classification E80XX-C2 or E70XXC2L, low hydrogen
- L AWS A5.11 Classification ENiCrMo-3
- M AWS A5.11 Classification ENiCrMo-6

<sup>1</sup> Table D.1 refers to coated electrodes. For bare wire welding (SAW, GMAW, GTAW), use equivalent electrode classifications (AWS A5.14, A5.17, A5.18, A5.20, A5.23, A5.28). Refer to the text for information on other processes.

<sup>2</sup> Higher alloy electrode specified in the table should normally be used to meet the required tensile strength or toughness after postweld heat treatment. The lower alloy electrode specified may be required in some applications to meet weld metal hardness requirements.

<sup>3</sup> Other E60XX and E70XX welding electrodes may be used if approved by the purchaser.

<sup>4</sup> This table does not cover modified versions of Cr-Mo alloys.

<sup>5</sup> See API 582, Section 6.1.3.



**Table D.2—Common Welding Consumables for SMAW of Carbon and Low-alloy Steel**

Base Material <sup>1,2,3</sup>	Type 405 Stainless Steel	Type 410S Stainless Steel	Type 410 Stainless Steel	Type 304 Stainless Steel	Type 304L Stainless Steel	Type 304H Stainless Steel	Type 310 Stainless Steel	Type 316 Stainless Steel	Type 316L Stainless Steel	Type 317L Stainless Steel	Type 321 Stainless Steel	Type 347 Stainless Steel
Carbon and Low-alloy Steel	AB	AB	AB	AB	AB	AB	AB	AB	AB	AB	AB	AB
Type 405 Stainless Steel	ABC	ABC	ABC	AB	AB	AB	AB	AB	AB	AB	AB	AB
Type 410S Stainless Steel		ABC	ABC	AB	AB	AB	AB	AB	AB	AB	AB	AB
Type 410 Stainless Steel			ABC	AB	AB	AB	AB	AB	AB	AB	AB	AB
Type 304 Stainless Steel				D	DH	DJ	A	DF	DGH	DI	DE	DE
Type 304L Stainless Steel					H	DHJ	A	DF	GH	HI	DE	DE
Type 304H Stainless Steel						J	A	DFJ	DGHJ	DIJ	DEJ	EJ
Type 310 Stainless Steel							K	AK	A	A	A	A
Type 316 Stainless Steel								F	FG	FI	EF	EF
Type 316L Stainless Steel									G	GI	EG	EG
Type 317L Stainless Steel										I	EI	EI
Type 321 Stainless Steel											E	E
Type 347 Stainless Steel												E

**Legend**

- A AWS A5.4 Classification E309-XX
- B AWS A5.11 Classification ENiCrFe-2 or-3<sup>4</sup>
- C AWS A5.4 Classification E410-XX [(0.05 % C max. and heat treatment @ 1400 °F (760 °C) required]
- D AWS A5.4 Classification E308-XX
- E AWS A5.4 Classification E347-XX
- F AWS A5.4 Classification E316-XX
- G AWS A5.4 Classification E316L-XX
- H AWS A5.4 Classification E308L-XX
- I AWS A5.4 Classification E317L-XX
- J AWS A5.4 Classification E308H-XX
- K AWS A5.4 Classification E310-XX

<sup>1</sup> Table D.2 refers to coated electrodes. For bare wire welding (SAW, GMAW, GTAW), use equivalent electrode classifications (AWS A5.9, A5.14). Refer to the text for information on other processes.

<sup>2</sup> The higher alloy electrode specified in the table is normally preferred.

<sup>3</sup> See API 582, Section 6.3, for weld metal delta ferrite requirements.

<sup>4</sup> See API 582, Section 6.2.2, for the temperature limitation for nickel-based filler metals.

Table D.3—Copper-nickel and Nickel-based Alloys

Base Material <sup>1</sup>	70-30 and 90-10 Cu-Ni	Alloy 400 (N04400)	Nickel 200 (N02200)	Alloy 800 (N08800), 800H (N08810), 800HT (N08811)	Alloy 600 (N066000)	Alloy 625 (N06625)	Alloy 825 (N08825)	Alloy C-22 (N-06022)	Alloy C-276 (N10276)	Alloy B-2 (N10665), B-3 (N10675)	Alloy G-3 (N06985)	Alloy G-30 (N06030)
Carbon and Low-alloy Steel	BC	BC	C	A	A	A	A	D	E	F	G	H
300-Series Stainless Steel	BC	AC	AC	A	A	A	A	D	E	F	G	H
400-Series Stainless Steel	B	B	AC	A	A	A	A	D	E	F	G	H
70-30 and 90-10 Cu-Ni	B	B	C	C	C	C	C	*	*	*	*	*
Alloy 400 (N04400)		B	BC	A	A	A	A	A	A	F	A	A
Nickel 200 (N02200)			C	AC	AC	AC	AC	CD	CE	CF	CG	CH
Alloy 800 (N08800), 800H (N08810), 800HT (N08811)				KJ	A	A	A	DJ	EJ	FJ	GJ	HJ
Alloy 600 (N066000)					A	AJ	A	DJ	EJ	FJ	GJ	HJ
Alloy 625 (N06625)						J	J	DJ	EJ	FJ	GJ	HJ
Alloy 825 (N08825)							J	DJ	EJ	FJ	GJ	HJ
Alloy C-22 (N-06022)								D	EJ	FJ	GJ	HJ
Alloy C-276 (N10276)									E	FJ	GJ	HJ
Alloy B-2 (N10665), B-3 (N10675)										I	GJL	HJL
Alloy G-3 (N06985)											G	HJ
Alloy G-30 (N06030)												H

\*An unlikely or unsuitable combination. Consult the purchaser if this combination is needed.

**Legend**

- A AWS A5.11 Classification ENiCrFe-2 or-3
- B AWS A5.11 Classification ENiCu-7
- C AWS A5.11 Classification ENi-1
- D AWS A5.11 Classification ENiCrMo-10
- E AWS A5.11 Classification ENiCrMo-4
- F AWS A5.11 Classification ENiMo-7
- G AWS A5.11 Classification ENiCrMo-9
- H AWS A5.11 Classification ENiCrMo-11
- I AWS A5.11 Classification ENiMo-10
- J AWS A5.11 Classification ENiCrMo-3
- K AWS A5.11 Classification ENiCrCoMo-1
- L AWS A5.11 Classification ENiCrMo-10 or -17

<sup>1</sup> Table D.3 refers to coated electrodes. For bare wire welding (SAW, GMAW, GTAW), use equivalent electrode classifications (AWS A5.14). Refer to the text for information on other processes.

**Table D.4—Classification Changes in Low-alloy Filler Metal Designations**

Material	ASME P-Number (Typical)	New (Current) AWS Filler Number		Old Filler Metal Designation	
		SMAW	GTAW	SMAW	GTAW
C- $\frac{1}{2}$ Mo	3	E7018-A1	ER70S-A1, or ER80S-D2	E7018-A1	N/A ER80S-D2
1Cr- $\frac{1}{2}$ Mo and 1 $\frac{1}{4}$ Cr-0.5 Mo	4	E7018-B2L E8018-B2	ER70S-B2L ER80S-B2	E8018-B2L E8018-B2	ER80S-B2L ER80S-B2
2 $\frac{1}{4}$ Cr-1 Mo	5A	E8018-B3L E9018-B3	ER80S-B3L ER90S-B3	E9018-B3L E9018-B3	ER90S-B3L ER90S-B3
5Cr- $\frac{1}{2}$ Mo	5B	E8018-B6 E8018-B6L	ER80S-B6	E502-XX E502-XX	ER502
9Cr-1 Mo	5B	E8018-B8 E8018-B8L	ER80S-B6	E505-XX E505-XX	ER505
Cr-1Mo- $\frac{1}{4}$ V	5B	E9018-B9	ER90S-B9	N/A	N/A

## Annex E (informative)

### Example Report of RT Results

<b>RADIOGRAPHIC INSPECTION REPORT</b>		Report No. _____	Technique _____
Client _____	Purchase Order Number _____		Job Number _____
Project _____	Location _____		Date of Radiography _____
<b>Component and Specification Data</b>			
Component/System _____		New _____ Type of Weld _____ Repair _____ R# _____	Root _____ Stage or Welding _____ Intermediate _____ Final _____
Material Type _____	Single Wall Thk. _____	Avg. Reinforcement _____ Backing Thickness _____	Thickness Range _____ Weld Process _____
Examination Specification _____		Acceptance Std. _____ Class _____	RT Procedure _____ Revs. _____
<b>Technique Data</b>			
IQI Type _____	IQI Designation _____	IQI Material _____	Sensitivity _____ Required _____ Obtained _____
IQI Selection Based on _____		Shim(s) Block(s) Material and Thickness _____ & or _____ S/S _____	Film Side _____ Source _____ Sirepair _____
S.F.D. _____	S.O.D. _____	O.F.D. _____	Focal Size _____ μG _____
KV _____	Ma-Curies _____	Exp. Time _____	Film Processing _____ Automatic _____ Manual _____
		Manual Process Time _____ Temp _____	Radiographic Technique _____ A B C D E F G or RSS Attached

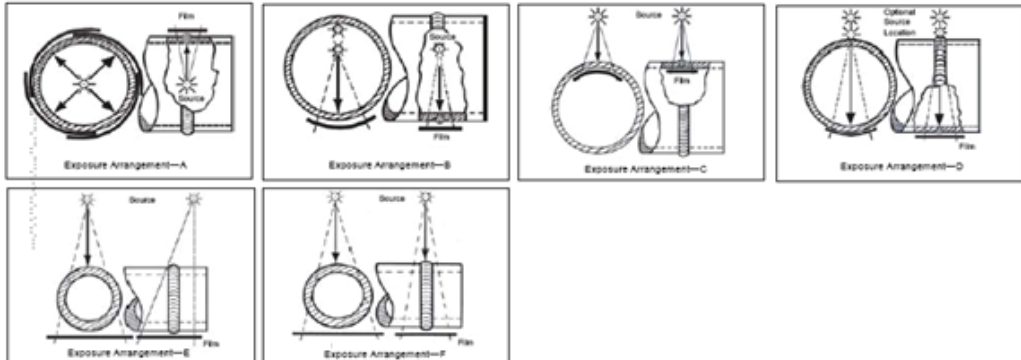

Interpretation Data													
Radiograph Identification	Radiograph Location	Accept	Reject	N.A.D.	Surface Cond.	*Discontinuity Code	# of Film	Single Viewing	Composite Viewing	IQI Density	Density Area	Location and Size of Conditions	
													1
													2
													3
													4
													5
													6
													7
													8

Examiner _____	Level _____	Date _____	Client Reviewer _____	Level _____	Date _____
Examiner _____	Level _____	Date _____	Client Reviewer _____	Level _____	Date _____

- |  |  |   |
|--|--|---|
| <p>*Discontinuity Code (Circle Reject Condition)</p> <ul style="list-style-type: none"> <li>1 Porosity</li> <li>2 Slag Inclusion</li> <li>3 Tungsten Inclusion</li> <li>4 Lack of Fusion</li> <li>5 Lack of Penetration</li> </ul> | <ul style="list-style-type: none"> <li>6 Crack</li> <li>7 Burn Through</li> <li>8 Hollow Bead</li> <li>9 Concave Root</li> <li>10 Convex Root</li> <li>11 Inside Undercut</li> </ul> | <ul style="list-style-type: none"> <li>12 Outside Undercut</li> <li>13 High Low</li> <li>14 Low Crown</li> <li>15 Drop Through</li> <li>16 Whisker</li> <li>17 Oxidation</li> </ul> |
|--|--|---|

- NAD—No Apparent Discontinuities
- U<sub>g</sub>—Geometric Unsharpness
- SFD—Source to Film Distance
- SOD—Source to Object Distance
- OFD—Object to Film Distance

## Bibliography

The following codes and standards are not referenced directly in this RP. Familiarity with these documents may be useful to the welding engineer or inspector as they provide additional information pertaining to this RP. For dated references, only the edition cited applies. For undated references, the latest edition of the referenced document (including any amendments) applies.

- [1] API Recommended Practice 572, *Inspection of Pressure Vessels*
- [2] API Publication 2207, *Preparing Tank Bottoms for Hot Work*
- [3] API Publication 2217A, *Guidelines for Work in Inert Confined Spaces in the Petroleum Industry*
- [4] ASME B16.5, *Pipe Flanges and Flanged Fittings*
- [5] ASME B16.9, *Factory-Made Wrought Steel Butt Welding Fittings*
- [6] ASME B16.34, *Valves—Flanged, Threaded, and Welding End*
- [7] ASME B31.1, *Power Piping*
- [8] AWS A2.4, *Standard Symbols for Welding, Brazing, and Nondestructive Examination*
- [9] AWS A3.0, *Standard Welding Terms and Definitions*
- [10] AWS B1.10, *Guide for the Nondestructive Inspection of Welds*
- [11] AWS JWE, *Jefferson's Welding Encyclopedia*
- [12] AWS CM-00, *Certification Manual for Welding Inspectors*
- [13] ISO 9712<sup>10</sup>, *Non-Destructive Testing—Qualification and Certification of NDT Personnel*
- [14] NB-23<sup>11</sup>, *National Board Inspection Code*

---

<sup>10</sup> The International Organization for Standardization, 1, ch. de la Voie-Creuse, CP 56, CH-1211 Geneva 20, Switzerland  
[www.iso.org](http://www.iso.org)

<sup>11</sup> The National Board of Boiler and Pressure Vessel Inspectors, 1055 Crupper Avenue, Columbus, Ohio 43229,  
[www.nationalboard.org](http://www.nationalboard.org).



# EXPLORE SOME MORE

Check out more of API's certification and training programs, standards, statistics and publications.

## API Monogram™ Licensing Program

Sales: 877-562-5187  
(Toll-free U.S. and Canada)  
(+1) 202-682-8041  
(Local and International)  
Email: [certification@api.org](mailto:certification@api.org)  
Web: [www.api.org/monogram](http://www.api.org/monogram)

## API Quality Registrar (APIQR™)

- ISO 9001
- ISO/TS 29001
- ISO 14001
- OHSAS 18001
- API Spec Q1®
- API Spec Q2™
- API Quality Plus™
- Dual Registration

Sales: 877-562-5187  
(Toll-free U.S. and Canada)  
(+1) 202-682-8041  
(Local and International)  
Email: [certification@api.org](mailto:certification@api.org)  
Web: [www.api.org/apiqr](http://www.api.org/apiqr)

## API Training Provider Certification Program (API TPCP®)

Sales: 877-562-5187  
(Toll-free U.S. and Canada)  
(+1) 202-682-8041  
(Local and International)  
Email: [tpcp@api.org](mailto:tpcp@api.org)  
Web: [www.api.org/tpcp](http://www.api.org/tpcp)

## API Individual Certification Programs (ICP™)

Sales: 877-562-5187  
(Toll-free U.S. and Canada)  
(+1) 202-682-8041  
(Local and International)  
Email: [icp@api.org](mailto:icp@api.org)  
Web: [www.api.org/icp](http://www.api.org/icp)

## API Engine Oil Licensing and Certification System (EOLCS™)

Sales: 877-562-5187  
(Toll-free U.S. and Canada)  
(+1) 202-682-8041  
(Local and International)  
Email: [eolcs@api.org](mailto:eolcs@api.org)  
Web: [www.api.org/eolcs](http://www.api.org/eolcs)

## Motor Oil Matters™

Sales: 877-562-5187  
(Toll-free U.S. and Canada)  
(+1) 202-682-8041  
(Local and International)  
Email: [motoroilmatters@api.org](mailto:motoroilmatters@api.org)  
Web: [www.motoroilmatters.org](http://www.motoroilmatters.org)

## API Diesel Exhaust Fluid™ Certification Program

Sales: 877-562-5187  
(Toll-free U.S. and Canada)  
(+1) 202-682-8041  
(Local and International)  
Email: [apidef@api.org](mailto:apidef@api.org)  
Web: [www.apidef.org](http://www.apidef.org)

## API Perforator Design™ Registration Program

Sales: 877-562-5187  
(Toll-free U.S. and Canada)  
(+1) 202-682-8041  
(Local and International)  
Email: [perfdesign@api.org](mailto:perfdesign@api.org)  
Web: [www.api.org/perforators](http://www.api.org/perforators)

## API WorkSafe™

Sales: 877-562-5187  
(Toll-free U.S. and Canada)  
(+1) 202-682-8041  
(Local and International)  
Email: [apiworksafe@api.org](mailto:apiworksafe@api.org)  
Web: [www.api.org/worksafe](http://www.api.org/worksafe)

## API-U®

Sales: 877-562-5187  
(Toll-free U.S. and Canada)  
(+1) 202-682-8041  
(Local and International)  
Email: [training@api.org](mailto:training@api.org)  
Web: [www.api-u.org](http://www.api-u.org)

## API eMaintenance™

Sales: 877-562-5187  
(Toll-free U.S. and Canada)  
(+1) 202-682-8041  
(Local and International)  
Email: [apiemaint@api.org](mailto:apiemaint@api.org)  
Web: [www.apiemaintenance.com](http://www.apiemaintenance.com)

## API Standards

Sales: 877-562-5187  
(Toll-free U.S. and Canada)  
(+1) 202-682-8041  
(Local and International)  
Email: [standards@api.org](mailto:standards@api.org)  
Web: [www.api.org/standards](http://www.api.org/standards)

## API Data™

Sales: 877-562-5187  
(Toll-free U.S. and Canada)  
(+1) 202-682-8041  
(Local and International)  
Service: (+1) 202-682-8042  
Email: [data@api.org](mailto:data@api.org)  
Web: [www.api.org/data](http://www.api.org/data)

## API Publications

Phone: 1-800-854-7179  
(Toll-free U.S. and Canada)  
(+1) 303-397-7956  
(Local and International)  
Fax: (+1) 303-397-2740  
Web: [www.api.org/pubs](http://www.api.org/pubs)  
[global.ihs.com](http://global.ihs.com)



AMERICAN PETROLEUM INSTITUTE

1220 L Street, NW  
Washington, DC 20005-4070  
USA

202-682-8000

**Additional copies are available online at [www.api.org/pubs](http://www.api.org/pubs)**

Phone Orders: 1-800-854-7179 (Toll-free in the U.S. and Canada)  
303-397-7956 (Local and International)  
Fax Orders: 303-397-2740

Information about API publications, programs and services is available  
on the web at [www.api.org](http://www.api.org).

**Product No. C57702**