

Instrumentation, Control, and Protective Systems for Gas Fired Heaters

API RECOMMENDED PRACTICE 556
SECOND EDITION, APRIL 2011



AMERICAN PETROLEUM INSTITUTE

Instrumentation, Control, and Protective Systems for Gas Fired Heaters

Downstream Segment

API RECOMMENDED PRACTICE 556
SECOND EDITION, APRIL 2011



AMERICAN PETROLEUM INSTITUTE

Special Notes

API publications necessarily address problems of a general nature. With respect to particular circumstances, local, state, and federal laws and regulations should be reviewed.

Neither API nor any of API's employees, subcontractors, consultants, committees, or other assignees make any warranty or representation, either express or implied, with respect to the accuracy, completeness, or usefulness of the information contained herein, or assume any liability or responsibility for any use, or the results of such use, of any information or process disclosed in this publication. Neither API nor any of API's employees, subcontractors, consultants, or other assignees represent that use of this publication would not infringe upon privately owned rights.

API publications may be used by anyone desiring to do so. Every effort has been made by the Institute to assure the accuracy and reliability of the data contained in them; however, the Institute makes no representation, warranty, or guarantee in connection with this publication and hereby expressly disclaims any liability or responsibility for loss or damage resulting from its use or for the violation of any authorities having jurisdiction with which this publication may conflict.

API publications are published to facilitate the broad availability of proven, sound engineering and operating practices. These publications are not intended to obviate the need for applying sound engineering judgment regarding when and where these publications should be utilized. The formulation and publication of API publications is not intended in any way to inhibit anyone from using any other practices.

Any manufacturer marking equipment or materials in conformance with the marking requirements of an API standard is solely responsible for complying with all the applicable requirements of that standard. API does not represent, warrant, or guarantee that such products do in fact conform to the applicable API standard.

All rights reserved. No part of this work may be reproduced, translated, stored in a retrieval system, or transmitted by any means, electronic, mechanical, photocopying, recording, or otherwise, without prior written permission from the publisher. Contact the Publisher, API Publishing Services, 1220 L Street, NW, Washington, DC 20005.

Copyright © 2011 American Petroleum Institute

Foreword

Nothing contained in any API publication is to be construed as granting any right, by implication or otherwise, for the manufacture, sale, or use of any method, apparatus, or product covered by letters patent. Neither should anything contained in the publication be construed as insuring anyone against liability for infringement of letters patent.

This document was produced under API standardization procedures that ensure appropriate notification and participation in the developmental process and is designated as an API standard. Questions concerning the interpretation of the content of this publication or comments and questions concerning the procedures under which this publication was developed should be directed in writing to the Director of Standards, American Petroleum Institute, 1220 L Street, NW, Washington, DC 20005. Requests for permission to reproduce or translate all or any part of the material published herein should also be addressed to the director.

Generally, API standards are reviewed and revised, reaffirmed, or withdrawn at least every five years. A one-time extension of up to two years may be added to this review cycle. Status of the publication can be ascertained from the API Standards Department, telephone (202) 682-8000. A catalog of API publications and materials is published annually by API, 1220 L Street, NW, Washington, DC 20005.

Suggested revisions are invited and should be submitted to the Standards Department, API, 1220 L Street, NW, Washington, DC 20005, standards@api.org.

Contents

	Page
1 Scope	1
1.1 Purpose	1
1.2 General	1
2 References	2
2.1 Normative References	2
2.2 Other References	2
3 Fired Heaters	3
3.1 General	3
3.2 Process Measurement	3
3.3 Process Control	19
3.4 Protective Systems	21
Figures	
1 Forced Draft Fired Heater—Fuel Side	22
2 Natural Draft Fired Heater—Fuel Side	23
3 Natural Draft Fired Heater—Process Side	24
Tables	
1 Alarm Summary Table	55
2 Safe State Table	56
3 Cause and Effects Table	61
4 Startup Sequence, Natural Draft Heaters	62
5 Startup Sequence, Forced Draft and Balanced Draft Heaters	64
Annex A (normative) Tube Rupture Considerations	66

Instrumentation, Control, and Protective Systems for Gas Fired Heaters

1 Scope

1.1 Purpose

1.1.1 This recommended practice (RP) provides guidelines that specifically apply to instrument, control and protective system installations for gas fired heaters in petroleum production, refineries, petrochemical and chemical plants.

1.1.2 A gas fired general service heater defined in this practice liberates heat by the combustion of fuel gas and this heat is transferred to liquids and/or gases in tubular coils all contained within an internally insulated enclosure.

1.1.3 **Not** covered in this RP are the following:

- oil fired and combination fired heaters;
- water tube boilers which consist of single or multiple burners and are designed for utility operation or where the primary purpose is steam generation (covered by NFPA 85);
- fired steam generators used to recover heat from combustion turbines [i.e. heat recovery steam generators (HSRG)];
- oven and furnaces used for the primary purpose of incineration, oxidation, reduction or destruction of the process medium (covered by NFPA 86);
- water bath or oil bath indirect fired heaters (covered by API 12K);
- CO boilers, pyrolysis furnaces (e.g. ethylene and hydrogen reformers), and other specialty heaters.

1.1.4 This RP includes primary measuring and actuating instruments, controls, alarms, and protective systems as they apply to fired heaters. For additional subject matter review, refer to the referenced or industry standards.

1.2 General

1.2.1 Instrumentation and control applications incorporate systems and devices to satisfy equipment specific requirements. Equipment specific requirements include safety, process control, data collection, environmental reporting and other local applications.

1.2.2 Documentation including schedules, drawings, sketches, specifications and other data should be provided to install the equipment in the desired manner and for the users to maintain, inspect, test and operate the system in a safe manner.

1.2.3 The various industry codes and standards as well as laws and rules of local regulating bodies shall be followed where applicable.

1.2.4 Although it is no substitute for experience and proficiency in these fields, this document is intended to assist users with achieving such experience and proficiency. Because of the lack of uniformity in the design and requirements of the processes, the complete instrumentation and control system must be studied to determine if it will enable the unit to be started-up, operated, and shut down satisfactorily and safely.

2 References

2.1 Normative References

The following referenced documents are indispensable for the application of this document. For dated references, only the edition cited applies. For undated references, the latest edition of the referenced document (including any amendments) applies.

API Specification 6FA, *Specification for Fire Test for Valves*

API Specification 12K, *Indirect Type Oil-Field Heaters*

API Recommended Practice 534, *Heat Recovery Steam Generators*

API Recommended Practice 535, *Burners for Fired Heaters in General Refinery Services*

API Recommended Practice 551, *Process Measurement Instrumentation*

API Recommended Practice 553, *Refinery Control Valves*

API Recommended Practice 554, *Process Control Systems, Part 1 through 3*

API Recommended Practice 555, *Process Analyzers*

API Standard 560/ISO 13705, *Fired Heaters for General Refinery Services*

API Recommended Practice 573, *Inspection of Fired Boilers and Heaters*

API Standard 598, *Valve Inspection and Testing*

API Standard 607, *Fire Test for Quarter-turn Valves and Valves Equipped with Non-Metallic Seats*

ANSI/ISA 84.00.01-2004 (IEC 61511-Mod)¹, *Functional Safety: Safety Instrumented Systems for the Process Industry Sector*

NFPA 325², *Guide to Fire Hazard Properties of Flammable Liquids, Gases, and Volatile Solids*, 1994 edition.

2.2 Other References

Certain systems are not covered in this document because of their specialized nature and limited use in petroleum refinery, hydrocarbon-processing, petrochemical, and chemical plants. When one of these systems gains general usage and installation reaches a fair degree of standardization, this document will be revised to provide additional information.

The following documents are not directly applicable to refinery heaters. These are referenced as they may be cited by regulatory bodies.

ANSI/FCI 70-2³, *Control Valve Leakage*

ASME, CSD-1⁴, *Controls and Safety Devices for Automatically Fired Boilers*

¹ American National Standards Institute, 25 West 43rd Street, 4th Floor, New York, New York 10036, www.ansi.org.

² National Fire Protection Association, 1 Batterymarch Park, Quincy, Massachusetts 02169-7471, www.nfpa.org.

³ Fluid Components International, 1755 La Costa Meadows Drive, San Marcos, California, www.fluidcomponents.com.

EN 746-2⁵, *Industrial thermo processing equipment, Part 2, Safety requirements for combustion and fuel handling systems*.

ISA TR.84.00.05⁶, *The Application of ANSI/ISA 84.00.01-2004 (IEC 61511) for Safety Instrumented Functions (SIFs) in Burner Management Systems*

NFPA 85, *Boiler and Combustion Systems Hazards Code*

NFPA 86, *Standards for Ovens and Heaters*

3 Fired Heaters

3.1 General

API 560 contains instrumentation requirements for fired heaters and their auxiliaries.

3.2 Process Measurement

Installation of instrumentation should consider accessibility for efficient maintenance and for good operation. Flow elements, control valves, transmitters, thermowells, level gauges, and local controllers, as well as analyzer sample points, generally should be readily accessible from grade or from permanent platforms or fixed ladders. In this document, special consideration is given to the location, accessibility, and readability of the elements. Refer to API 551 for installation details.

3.2.1 Temperature

Continuous temperature measurement in fired heater applications generally uses thermocouples.

3.2.1.1 Bridgeway Temperature

The bridgeway temperature is the temperature of flue gas leaving the radiant section. Each heater and each cell of a heater should have a bridgeway temperature thermocouple located at least two feet into the firebox and just upstream of the convection section. This temperature is used for trending the approximate flue gas temperature. Highly accurate temperature measurement here is not necessary for normal refinery service heaters.

- Long/large fireboxes may require several bridgeway temperature measurements along the length of the box. These measurements may be useful in assessing the uniformity of heat distribution along the length of the firebox.
- Thermocouples in the radiant section should be installed with wells or other protective devices. The point of measurement should not have flame impingement. The thermocouples should extend past the shadow of the tube and be placed to avoid dead spots.
- A sample port next to the thermowell location is recommended to allow temperature verification.
- Thermowell materials must be suitable for the firebox temperatures and atmosphere. American Iron and Steel Institute (AISI) Types 446 and 347 stainless steel are generally acceptable materials. For some severe services, 310 stainless steel, nickel chromium iron alloy, ceramic, or ceramic-coated thermowells have been used.

⁴ ASME International, 3 Park Avenue, New York, New York 10016-5990, www.asme.org.

⁵ European Committee for Standardization, Avenue Marnix 17, B-1000, Brussels, Belgium, www.cen.eu.

⁶ International Society of Automation, 67 Alexander Drive, Research Triangle Park, North Carolina, 22709, www.isa.org.

3.2.1.2 Radiant Floor Flue Gas Temperature

A floor flue gas temperature measurement may be considered to detect operating conditions that can lead to an unstable flame condition in some radiant floor mounted, low NO_x burners with internally recirculated flue gas, especially at low flue gas oxygen levels. For further information see API 535 and discuss specific burner operating envelope concerns with the burner manufacturer. See 3.2.1.1 for additional guidance on firebox temperature measurement.

3.2.1.3 Convection Section Temperature

Flue gas temperature measurement within the convection section may be useful when multiple services are located there. Flue gas thermocouples may be located between the different services to cross-check their heat absorbed duties.

3.2.1.4 Stack Temperature

Stack temperature measurement is useful both for monitoring the heater condition (trending of typical operation) and as a component used to monitor efficiency. Stack temperature is generally grouped with other operating variables (i.e. stack oxygen, etc.) to achieve these results.

- A thermocouple in a thermowell should be installed in the stack. The portion of the breeching where the thermocouple is installed may not be representative of the fully mixed flue gas in the stack. Some areas of breeching may be in low flow zones and not representative of fully mixed flue gas in the stack.
- Multiple stack heaters should have the flue gas temperature measured in each stack.
- If a common stack is used with several heaters, each heater should have a temperature measurement in the ducting to the common stack. The common stack should still have a temperature measurement point to monitor heater efficiency and environmental performance. The common stack temperature measurement will also be useful to detect afterburning.
- On convection sections with multiple ducts to a common stack temperature measurement in each duct should be considered. This could be done with a test thermowell or on-line to assist with monitoring maldistribution.
- The stack temperature measuring device should be located near enough to the entrance of the stack so external heat losses will not have reduced the flue gas temperature. It should be placed far enough from the entrance to allow for the flow to be fully mixed and developed.
- Thermowell insertion length should be sufficient to minimize the measurement effects of the stack wall and the heat loss from the portion of the well exposed to ambient conditions. Excessive length should be avoided as stack gas induced frequency vibration of the thermowell is amplified by thermowell length.

3.2.1.5 Process Inlet and Outlet Temperatures

All heaters should have temperature measurements on the outlet and their common inlet. Usually a thermocouple with a thermowell is installed in the following areas except in many single-phase heaters with a large multiplicity of passes (i.e. many catalytic reforming heaters):

- the common inlet to the heater,
- the crossover from the convection section to the radiant section for each pass,
- outlet of the heater for each pass,
- the combined outlet from the heater.

Thermowells should be located so that they are exposed to the stream and are neither in a stagnant location nor where they might be insulated by coke deposits. If they are installed in an elbow, they should be installed so that the end of the well faces the flowing charge. This position helps keep the tip clean and ensures better response. Erosion from flow and the consequent vibration that might lead to fatigue of the well are also reduced. Thermowells should be removable for pigging or decoking, as applicable.

3.2.1.6 Tube-skin Thermocouples

Tube-skin thermocouples are used to monitor tube metal temperature.

- The number and position of tube-skin thermocouples depend on considerations such as tube coil geometry, burner orientation, and the potential to overheat due to process coking. The objective is to monitor the hottest tube locations in normal operation and locations which have a potential to overheat.
- When tube skin thermocouples are considered, the recommended minimum is two tube-skin thermocouples per pass.
- The placement of tube-skin thermocouples should be done in conjunction with a fired heater specialist experienced with the specific application.
- The thermocouple and leads must be able to withstand the severe environment within the heater. To achieve a satisfactory length of service, consider the use of a sheath material with a high temperature resistance. Fired heater skin thermocouples are severe services and replacement of these elements after each heater maintenance interval should be considered.
- Protection of the thermocouple element, through shielding, and the lead wire, through routing, from the flame as well as the corrosive atmosphere of the firebox is essential. The thermocouple element should be on the fireside of the tube. The lead wire routing should not be exposed to the flame. Flexibility must be adequate to accommodate heater tube expansion. The sheath material must resist both corrosion and embrittlement.
- The skin thermocouple assembly must be in direct contact with the tube. The protected thermocouple attachment must be welded to the tube on the hot face, towards the burners and not facing the refractory for a single-fired tube arrangement. Any gap between the tube and the thermocouple attachment will cause an erroneously high reading because the thermocouple will read the firebox temperature, not the tube temperature. Manufacturer's installation procedures together with strict adherence to approved quality control are very important to assure proper operation of the thermocouple.

3.2.1.7 Fuel Gas Temperature

Historically fuel gas headers have been at ambient conditions. However, to improve burner reliability fuel gas treatment is implemented. This treatment includes warming the fuel gas to avoid condensation and precipitation of contaminants at the burners. When orifice plate based fuel gas flow measurement and temperature compensation is used, the fuel gas temperature should be measured close to the orifice plate but not interfering with the straight run requirements of the meter run. See 3.2.3.1 for fuel gas flow.

3.2.1.8 Combustion Air Preheater Temperature

When a combustion air preheater is used, multiple temperature measurements are required in evaluating preheater performance. These should be located at the following points.

- Provide multiple thermocouples to monitor coldest metal temperature in contact with flue gas. This is typically near the flue gas outlet near the air inlet, but each design should be evaluated to determine the best location. During operation, combustion air should be bypassed around the combustion air preheater as needed to maintain the metal surface temperature above the acid dew point.

- Flue gas inlet to combustion air preheater.
- Inducted draft (ID) fan inlet (combustion air preheater flue gas discharge, sufficiently downstream of the air preheater to allow the flow to be fully mixed).
- Air temperature to the combustion air preheater (ambient reading is sufficient if the combustion air is not heated prior to the combustion air preheater).
- Forced draft air preheater outlet (upstream of air bypass duct), yet sufficiently downstream of the air preheater to allow the flow to be fully mixed.
- Combustion air to burners (downstream of air bypass duct).

3.2.2 Draft and Pressure

3.2.2.1 Draft

3.2.2.1.1 Definitions

For the purposes of this document the following definitions apply.

- When the differential pressure between the inside pressure of the heater and the atmospheric pressure at the same elevation is less than zero this is referred to as draft. When this value is positive this is referred to as positive pressure.
- A positive draft value indicates the pressure of the flue gas inside the fired heater is less than the pressure of the atmosphere outside the heater at a given elevation (i.e. the flue gas side of the fired heater is under a slight vacuum). For example, a draft of 0.1 in. H₂O (2.5 mm H₂O) of water column is equivalent to saying the pressure of the flue gas is 0.1 in. H₂O (2.5 mm H₂O) less than the air pressure at the same elevation.
- Low draft refers to the case where the pressure of the flue gas inside the heater is greater than normal. As the pressure of the flue gas approaches the pressure of the atmosphere outside the heater at a given elevation, the draft at that elevation approaches zero.
- It is possible for the pressure of the flue gas to exceed the pressure of the atmosphere outside the heater at a given elevation. When this happens, the draft at that elevation is negative. High draft refers to the case where the pressure of the flue gas inside the heater is less than normal (i.e. the amount of vacuum is greater than normal).

3.2.2.1.2 Discussion

Draft is typically measured at the following locations (see API 560 for additional information):

- near the floor using a gauge or transmitter;
- at the bridgewall using both a transmitters and a gauge;
- below the stack damper, using a gauge or transmitter.

Draft at various points on a heater are typically displayed on a panel at grade. The bridgewall is the preferred location for monitoring and control of draft inside the heater.

The pressure taps and instrumentation used for control and shutdown should be independent. To ensure measurement accuracy at the target bridgewall draft of 0.1 in. H₂O (2.5 mm H₂O) [– 0.1 in. H₂O (– 2.5 mm H₂O) differential pressure], match the transmitter cell range to the measurement range as closely as possible. A typical cell

range for flue gas draft is – 3 to + 3 in. H₂O (– 75 to + 75 mm H₂O) 30:1 turndown. A higher cell range may not have the desired sensitivity at the target draft.

Climatic conditions can cause problems with measuring draft and require operator vigilance during significant atmospheric pressure changes. The connection to the heater should be free draining into the heater to mitigate the effects of condensation. The reference leg exposed to atmosphere shall be free draining and protected from wind, insects, rain, and condensation.

NOTE 1 Draft at the bridgewall or arch is typically controlled between 0.05 and 0.2 in. H₂O (1 to 5 mm H₂O) draft.

NOTE 2 When draft at the arch is decreased, draft at the burner is decreased by approximately the same amount.

NOTE 3 For a natural draft burner with ambient pressure at the air inlet, draft at the burner/tile outlet is equal to the air side pressure drop across the burner.

NOTE 4 The air flow through the burner is proportional to the square root of the air side pressure drop.

NOTE 5 Changes in draft have a greater impact on the combustion air flow of shorter natural draft heaters than it does for taller heaters.

3.2.2.1.3 Changes in Bridgewall Draft—Examples of Impact on Stoichiometry ⁷

The examples listed below are intended to demonstrate that a step change in draft at the bridgewall may yield sub-stoichiometric conditions at the burner. Especially for the high draft case, it is possible to make a large change in draft, not reach a low draft alarm and still move the air flow to sub-stoichiometric conditions.

For each example, the following assumptions apply:

- non-premix, natural draft burners, floor fired;
- 0.01 in. H₂O per ft (0.1 mm H₂O per m) of firebox height;
- burner registers are adjusted to achieve the % stoichiometric air flow before the change in draft;
- draft is changed by moving the stack damper, burner air registers don't move during the change;
- alarm at 0 draft at the bridgewall.

EXAMPLE 1 30 ft (10 m) tall firebox, draft on target before small draft change, air flow moves to stoichiometric:

Measured Variable	Units of Measurement	Before Draft Change	After Draft Change
air flow	% stoichiometric	115	99.6
draft at the bridgewall	in. H ₂ O (mm H ₂ O)	0.1 (2.5)	0 (0)
draft at the floor	in. H ₂ O (mm H ₂ O)	0.4 (10)	0.3 (7.5)
Air flow after the change = 115 % * SQRT(0.3 / 0.4) = 99.6 % stoichiometric			

⁷ These are merely examples for illustration purposes only. Each company should develop its own approach. They are not to be considered exclusive or exhaustive in nature. API makes no warranties, express or implied for reliance on or any omissions from the information contained in this document.

EXAMPLE 2⁷ 30 ft (10 m) tall firebox, high draft before medium draft change, air flow goes sub-stoichiometric:

Measured Variable	Units of Measurement	Before Draft Change	After Draft Change
air flow	% stoichiometric	115	89.1
draft at the bridgewall	in. H ₂ O (mm H ₂ O)	0.2 (5)	0 (0)
draft at the floor	in. H ₂ O (mm H ₂ O)	0.5 (12.5)	0.3 (7.5)
Air flow after the change = 115 % * SQRT(0.3 / 0.5) = 89.1 % stoichiometric			

EXAMPLE 3⁷ 60 ft (20 m) tall firebox, draft on target before medium draft change, air flow stays above stoichiometric:

Measured Variable	Units of Measurement	Before Draft Change	After Draft Change
air flow	% stoichiometric	115	106.4
draft at the bridgewall	in. H ₂ O (mm H ₂ O)	0.1 (2.5)	0 (0)
draft at the floor	in. H ₂ O (mm H ₂ O)	0.7 (17.5)	0.6 (15)
Air flow after the change = 115 % * SQRT(0.6 / 0.7) = 106.4 % stoichiometric			

EXAMPLE 4⁷ 60 ft (20 m) tall firebox, high draft before large draft change, air flow moves to sub-stoichiometric, low draft alarm not triggered:

Measured Variable	Units of Measurement	Before Draft Change	After Draft Change
air flow	% stoichiometric	115	91.7
draft at the bridgewall	in. H ₂ O (mm H ₂ O)	0.5 (12.5)	0.1 (2.5)
draft at the floor	in. H ₂ O (mm H ₂ O)	1.1 (27.5)	0.7 (17.5)
Air flow after the change = 115 % * SQRT(0.7 / 1.1) = 91.7 % stoichiometric			

3.2.2.2 Combustion Air Pressure

In general, combustion air pressure is measured at the following locations for heaters with air ducting (see API 560 for additional information):

- the inlet of the fan using a gauge,
- the outlet of the fan using a gauge,
- downstream of all combustion air dampers and preheater using a transmitter.

The transmitter should be located downstream of control dampers and preheater but far enough upstream of the burners that combustion air pressure at the measurement point will yield sufficiently high pressure even at turndown combustion air flow rates. Otherwise, the heater may be subject to spurious trips on low combustion air pressure. Alternatively, place the transmitter upstream of the combustion air damper with a minimum flow mechanical stop on the damper set for minimum air flow requirements.

It is generally recommended that the trip setpoint is not below the minimum span of the transmitter cell range. For example, the minimum span for a typical 3 in. H₂O (75 mm H₂O) cell range is 0.1 in. H₂O (2.5 mm H₂O). The minimum span for a typical 25 in. H₂O (625 mm H₂O) cell range is 0.5 in. H₂O (12.5 mm H₂O). A higher cell range may not have the desired sensitivity at the target trip setpoint.

The recommended location for combustion air pressure is typically at the smallest cross-sectional area of the inlet air plenum downstream of control dampers and preheater that yields the highest static pressure. Due to the size of ducts, however, the pressure at the desired air flow trip setpoint may be very low.

3.2.2.3 Flue Gas Pressure

3.2.2.3.1 Flue Gas Duct Upstream and Downstream of an Induced Draft (ID) Fan

In general, draft is measured in flue gas ducts at the following locations (see API 560 for additional information):

- inlet of the induced draft fan using a transmitter (to detect loss of ID fan),
- outlet of the induced draft fan using a gauge.

3.2.2.3.2 Combustion Air Preheat Systems

To aid in the evaluation of a combustion air preheater's performance, add pressure taps at the inlet and outlet of the air and flue gas sides of the exchanger. A differential pressure gauge is recommended for the flue gas side.

3.2.2.4 Fuel Gas Pressure

Fuel gas supply pressure should be measured upstream of the fuel gas control valves and downstream of the fuel gas preparation system. Burner pressure should be measured downstream of the fuel gas control valve and at a minimum distance from the distribution header.

Fuel gas burner pressure should be measured downstream of the fuel gas pressure control valve. The piping pressure drop from the pressure measurement point to the burner should be designed for no more than $1/2$ psi at maximum heat release for all anticipated fuel gas compositions. It is generally recommended that a trip setpoint is not below the minimum span of the transmitter cell range. Thus, separate transmitters to measure the low and high alarm and trip points may be required depending upon the cell range selected and the turndown capability of the transmitter.

3.2.2.5 Process Pressure

Pressure measurement of the flow passes should be located downstream of the pass control valve. It should be considered in coking and/or fouling services for troubleshooting.

For vaporizing services, especially on vacuum heaters, a process pressure measurement should accompany the temperature measurement at the combined outlet/transfer line.

3.2.3 Flow

3.2.3.1 Fuel Flow

A flow meter should be installed in the main fuel line located upstream of the fuel control valve where the pressure is relatively constant. To compensate for changes in fuel gas composition, the heat content may be measured by either analysis or inferred from fuel gas specific gravity. Analyzers are available to measure the flowing density and compensate for the temperature and pressure of the sample to determine specific gravity. The specific gravity of the gas is the ratio of the molecular weight of the mixture divided by the molecular weight of air. However, if the fuel gas composition contains varying amount of inert compounds (such as carbon dioxide or nitrogen), a Wobbe Index meter or Heat of Combustion meter is recommended for those applications where large step changes in heat content may adversely impact combustion control. See 3.2.5 for fuel gas heating value.

Since the heating value of light hydrocarbon gas mixtures, without varying amounts of inert gases, correlates closer to mass flow than volume flow it is recommended to control the mass flow of fuel gas to the heater. This minimizes the

impact to the process due to changes in fuel gas composition. If orifice plate flow meters are used to measure fuel gas mass flow, the measurement can be compensated by the flowing density of the fuel gas measured at the same temperature and pressure as the orifice plate. The orifice differential pressure multiplied by the flowing density is proportional to the square of the mass flow. Alternatively, a coriolis meter can be used to directly measure the mass flow without compensation.

3.2.3.2 Charge Flow

Flow measurement and the flow control valve(s) shall be located upstream of the heater coil.

- If the charge is divided into two or more streams through the heater, the flow in each pass should be measured in liquid services. This measurement is used for pass balancing, which in turn helps prevent coking and plugging of each pass.
- The flow can be split with manually operated valves if it tends to remain stable. If the heated fluid is partially vaporizing in the heater, the system may be unstable and may require flow controllers to hold the split constant.
- If the charge at the point of measurement is two phase flow, it will be necessary to determine the split by some method other than flow measurement since conventional flow measurement methods are not reliable in two phase service. Two phase flow cannot be measured reliably therefore the liquid and vapor phase flows should be individually controlled for each pass. Where the liquid and vapor phase flows are combined upstream of the heater, orifice plates with a differential pressure measurement on each pass can be used to assist with flow balancing (see 3.3.2).
- Pressure readings downstream of flow-splitting valves or differential pressure across the valve on each inlet may be of value to infer flow. However, it must be remembered this reading may be misleading if coking, vaporization, or tube blockages in each pass vary.
- For vapor-charged heaters, individual pass flow measurement is typically not required when symmetrical piping provides balanced flow.
- Where pass flow controllers are utilized, fail open control valves with a minimum flow mechanical stop to prohibit full closure are recommended to prevent loss of pass flow.
- For heavy coking services (crude, resid, asphalt), measurement is often specialized and may require vortex, coriolis, ultrasonic or wedge type meters.

3.2.3.3 Combustion Air Flow

Air flow in forced-draft or balanced draft heaters is often difficult to obtain. Direct or inferred methods of obtaining this measurement include the following examples.

- Flow elements located in the forced-draft duct system (for example, venturi, averaging pitot tubes, and thermal mass). This measurement may not be operable during natural draft operating mode. Limited straight run of air duct and close proximity to dampers can significantly impair accuracy and quality of air flow measurements. For applications with insufficient straight run of duct, multi-point thermal mass arrays may yield significant improvement to measurement accuracy and turndown. Averaging flow elements, flow rings, or grids can also have applicability in measuring air flow in short ducts.
- Inferred air flow by measuring differential pressure across the air preheater is unreliable due to changes in pressure and temperature. Additional consideration should be given to possible air leakage or soot blower effect if measurement is on the flue gas side.

- It is generally recommended that the trip setpoint is not below the minimum span of the transmitter cell range. For example, the minimum span for a typical 3 in. H₂O (75 mm H₂O) cell range is 0.1 in. H₂O (2.5 mm H₂O). The minimum span for a typical 25 in. H₂O (625 mm H₂O) cell range is 0.5 in. H₂O (12.5 mm H₂O). A higher cell range may not have the desired sensitivity at the target trip setpoint.

3.2.4 Flue Gas Analysis

For specific analyzer type selection and installation practices, refer to API 555 and local regulatory requirements.

3.2.4.1 General

Flue gas analyzers are used to monitor the safety and efficiency of the combustion process and to monitor and report flue gas emissions. These two functions are typically independent and have a different measurement basis (e.g. wet or dry), accuracy, response time, and maintenance requirements. Identification of the measured components and selection of the sample locations are determined by process control, process safety, or regulatory requirements. Inferential methods may also be an acceptable technique to meet these requirements, subject to regulatory approval.

The number of analyzers and sample locations are based upon many considerations including: heater type, heater control strategy, number of sections (cells) and stacks, configuration of the radiant and convection sections, damper locations, damper control, and fuel gas composition. In general, the sampling points should be located at the bridgewall or in the stack.

The location of the sampling point within the flue gas stream is important in obtaining a representative sample. For analyzers located at the bridgewall, sample probes may penetrate into the furnace 24 in. (600 mm) or more from the inside wall. Customized probe lengths are available to ensure the sample taken is representative of the majority of the flue gas flowing out of the radiant section.

For stack analyzers, air leakage (tramp air) into the fired heater upstream of the sample point will affect the concentration of the sample gas being analyzed. Sampling points should be selected to minimize this effect.

Periodic verification of analyzer performance is recommended to confirm the ability to satisfy both process control and process safety requirements. To meet these criteria, it is important to note that analyzer vendors may publish sensor response differently. While some publish the quickest response to calibration gas, others publish a more useful response to T63 or T90, i.e. 63 % or 90 % final value to a process step change. Measuring the response time to a process step change (not to calibration gas) is recommended to meet the control and safety requirements.

- Where possible, first isolate the analyzer's sensor response to a process step change. For close-coupled extractive systems, back flow the sample probe or transport tube with instrument air, nitrogen or calibration gas. Once the sensor has stabilized, return the system to normal operation. The response time to return to 63 % or 90 % final value may be compared against the vendor published response times. This technique isolates response issues associated with the analyzer. A slow response may indicate the aspirator, flame arrestors, or sample probe need cleaning or a sensor needs changing.
- When evaluating the process response time maintain a safe operating margin above combustibles breakthrough. Care is required, especially during step changes in firing rate, to prevent fuel rich combustion during analyzer testing. As an example, this may be done via a small step change reduction in the firing rate (in manual mode) while monitoring the corresponding change in excess air at the O₂ analyzer.
- Once the analyzer's sensor response has been validated, test the analyzer's process response to a step change in flue gas composition. The objective is to measure the process response, not the control system response in automatic mode. Once the process response time has been determined, a ramp rate may be configured in either the air/fuel ratio or fuel gas controller to ensure that a process step change may be detected within the overall

response time of the control loop. A slow process response may indicate that the sample probe is not sampling from the main body of the flue gas flow pattern because of improper probe length and/or sample location.

Regulatory requirements typically specify Continuous Emissions Monitoring Systems (CEMS) measurement of stack samples on a dry basis with diluent correction. Stack sample location is also specified by the regulation. CEMS measurements are typically made by utilizing an extractive analyzer sample conditioning system and must be independent from analyzers used for process control. These measurements may include a combination of NO_x, SO_x, CO and the diluents oxygen and/or CO₂.

Combining two heaters into one CEMS is not typically permitted. Verify regulatory and permit requirements before combining multiple heaters into a single CEMS analyzer.

3.2.4.2 Oxygen

One oxygen analyzer should be provided for each independent heater combustion zone. For large combustion zones one analyzer for every 30 ft (10 m) of firebox length is recommended due to non-uniformities in the firebox flue gas circulation and to facilitate balancing the burners. Oxygen measurements should be taken as near as possible to the point where combustion is completed, normally at the exit of the radiant section and before the transition to the convection section to avoid tramp air. To minimize the impact of air ingress, stack measurements for oxygen concentrations should be avoided where possible. If a stack sample is utilized, a portable oxygen analyzer should be used to prove heater integrity (no air leaks) by directly correlating the stack measurement with the oxygen concentration leaving the radiant section. Stack measurement for control is only an option if the heater is properly sealed.

Note that percent oxygen measurement is a process control variable which may be used for improving heater efficiency and maintaining safe heater operation. Percent excess combustion air should not be confused with percent oxygen measurement.

ZrO₂ sensors are "net oxygen" analyzers which are heated and utilize platinum electrode with catalytic properties and will burn any combustible compounds with oxidation potential such as hydrocarbons, CO, hydrogen, and high concentrations of sulfur dioxide. The analyzer will read the resulting oxygen after this combustion, typically a lower value.

- During combustibles breakthrough, H₂ and CO are typically the largest combustible components. The ratio of consumption for H₂ and CO to oxygen at a heated ZrO₂ sensor is approximately 2:1. As an example, a sample with 2000 ppm (0.2 %) H₂ and CO has the potential to consume 0.1 % oxygen at the sensor. Likewise, a sample with 10,000 ppm (1.0 %) H₂ and CO has the potential to consume 0.5 % oxygen at the sensor. Therefore, at low oxygen levels, it is possible for a high concentrations of H₂ and CO to mask (malfunction low) the true oxygen concentration at the sensor.
- Upon complete loss of flame, methane may be the largest component. The ratio of consumption of methane to oxygen at a heated ZrO₂ sensor is approximately 1:2. As an example, a sample with 1 % methane has the potential to consume 2 % oxygen at the sensor. Likewise, a sample with 5 % methane has the potential to consume 10 % oxygen at the sensor. Therefore, in a fuel rich environment, it is possible for a high concentration of methane to mask (malfunction low) the true oxygen concentration at the sensor.

Nitrogen backup to the instrument air system has the potential to create an oxygen analyzer malfunction high. ZrO₂ sensors make their measurement based on the difference in the partial pressure of oxygen between a reference gas and a process sample. Typically the reference gas is ambient air; however, instrument air may be used as it is readily available in most industrial facilities. When instrument air is backed up by nitrogen a change in the oxygen concentration of the reference gas will occur and false readings will be generated by the analyzer. In the case of an instrument air supply that has been changed to nitrogen, the oxygen concentration derived by the analyzer will be

higher than the actual concentration at the sampling location. If all instrument air is completely replaced by nitrogen, the analyzer will read 100 % full scale which is an obvious fault condition.

- An oxygen analyzer with heated ZrO₂ sensor is a potential ignition source during the purge cycle. Mitigation options include a purge interlock to disconnect sensor power, reverse flow of close-coupled extractive systems, or flame arrestors. See 3.4.7.1 for additional considerations.
- For both close-coupled extractive and in-situ probe systems, flame arrestors may be specified to prevent flame propagation to flue gas due to ignition of gases by the heated sensor; however, they add lag time (estimated 5 seconds to 10 seconds extractive and 1 minute for in-situ probe systems). Due to the lag time addition, flame arrestors are not recommended for process control or process safety applications where response time is critical. An alternate technique for preventing flame propagation to flue gas without adding lag time is to blowback the instrument air used for the aspirator to the flue gas through the sample probe during the purge cycle.
- For those high temperature ZrO₂ sensors that derive their sensor heating from the flue gas, it is important to note that they do not function properly until the flue gas temperature rises to the point where the ZrO₂ sensor becomes active, typically 1000 °F to 3000 °F (500 °C to 1650 °C). Thus, the impact of reduced firing rates on measurement accuracy must be considered.

Laser based technology for combustion control (oxygen trim to air or air/fuel ratio controller) is a design consideration for heater applications where a single sample point will not provide a representative sample. It has a response time of ≤ 5 seconds and can measure across a radiant section up to 100 ft (30 m). It is not an ignition source to flue gas and requires no reference air.

- Since the line-of-sight laser measurement inherently averages the concentration across the total length of the flue gas path, it will not provide indication of the source of oxygen variability in the flue gas as with the multiple point measurements. However, the “path average” measurement inherently samples a much larger cross section of the flue gas increasing the likelihood of a representative measurement. The larger sample cross-section can also improve the chances of detecting CO breakthrough from individual burners
- Laser measurement of oxygen does not require reference air for sensor performance, but purge air is typically required in order to prevent direct contact between the process flue gases and instrument optics, and the resulting damage from soiling and heat.
- Optical alignment is critical and can shift as the heater warms up. Thus, alignment should be performed at normal heater operating temperatures. Some tunable diode laser (TDL) designs have optics designed for long path lengths. The laser beam is diverged providing an increasing diameter as the path length increases; this improves alignment stability and allows alignment to be performed at start up temperature while maintaining alignment through the entire heater temperature range. This has been field proven at path lengths of up to 100 ft (30 m).
- The United States federal Environmental Protection Agency (USEPA) has not approved line-of-sight laser-based systems for use in CEMS applications, since they cannot be calibrated online with a calibration gas. Some analyzers can be validated online through “dynamic spiking”, a method referenced by USEPA (See EPA PPS-001). Some states have accepted TDL for CEMS measurements in thermal oxidizers and kilns. Typically the combustion control analyzers are not used for CEMS reporting, since the ideal combustion control measurement is in the radiant or crossover section. The oxygen and CO levels will be considerably different than in the stack (heater output). Oxygen will increase between the radiant section and the stack due to air ingress (tramp air), and CO will decrease between the radiant section and the stack due to afterburning [if the radiant section is above 1300 °F (700 °C)].

When oxygen is measured as a regulatory requirement (as a diluent), it is measured independently from analyzers used for process control. This oxygen analyzer is part of the CEMS and utilizes the CEMS sample system and reporting mechanism according to federal, state and local regulations and permit requirements.

3.2.4.3 Combustibles

Combustibles measurement may be used to detect the onset of incomplete combustion. These analyzers are typically manufactured as combination in-situ or close-coupled extractive oxygen/combustibles analyzers. When used, one combustibles analyzer should be provided for each heater cell. For large cells, due to non-uniformities in the firebox flue gas circulation and to facilitate balancing the burners, one analyzer for every 30 ft (10 m) of firebox length is recommended. Combustibles measurements should be taken as near as possible to the point where combustion should be completed, normally at the bridgewall. Combustibles should not be measured in the stack due to the potential for afterburning in the convection section.

High levels of combustibles in the flue gas may be an indication of burner tip plugging or improper burner operation or a change in fuel gas heating value.

Since catalytic bead or hot wire technology requires the presence of oxygen for combustibles detection, some sensors may report lower than actual combustible values at low oxygen concentrations. As the measured oxygen concentration approaches 0 %, some analyzers will automatically (via software) drive the combustibles measurement to full scale. Other analyzers supply the CO and/or combustibles sensor with independently sourced “auxiliary, supplemental, or dilution” air to permit combustibles measurement through the low oxygen condition. Ultimately, the user should ensure a fail-safe mechanism is provided for this hazard scenario to ensure safe heater operation.

A combustibles analyzer (catalytic bead) will typically detect CO, hydrogen, and other combustibles (excluding methane). Since the methane molecule cracks at a high temperature, detecting methane typically requires a separate sensor. Thus, the term “combustibles” can be easily misinterpreted and subsequently misapplied.

A combustibles analyzer with a heated catalytic sensor is a potential ignition source during the purge cycle. Mitigation options include a purge interlock to disconnect sensor power, reverse flow of close-coupled extractive systems, or flame arrestors. See 3.4.7.1 for additional considerations.

3.2.4.4 Carbon Monoxide (CO)

3.2.4.4.1 CO Control

When controlling a fired heater’s air/fuel ratio near the CO breakthrough point, an infrared or laser based CO specific measurement is recommended. In a properly designed system, oxygen control at levels < 1 % may be acceptable. However, the final control elements (e.g. stack dampers, automated burner registers and/or combustion air dampers) must have sufficient accuracy, turndown and repeatability to keep the heater in a safe operating region.

For process control, infrared or laser based analyzer technology with a response time ≤ 5 seconds is recommended. Although CO is detectable with a typical catalytic bead combustibles sensor, it has a response time of 20 seconds to 25 seconds to T90.

As noted in 3.2.4.2, the laser and infrared are typically “line-of-sight” measurements that inherently average across the total flue gas path. This averaged reading requires only one instrument, but it will not provide indication as to the source of CO variability in the flue gas, as with the multiple point measurements.

To minimize lag time issues and to avoid complications associated with the potential for afterburning, the CO measurement should be taken as near as possible to the point where combustion should be completed (e.g. at the top of the radiant section). However, some fired heaters with an infrared CO measurement in the stack may be successfully controlled where the flue gas temperature entering the convection section is rapidly reduced below 1200 °F (600 °C) to minimize the rate of CO afterburning. If the flue gas temperature is not rapidly reduced below 1200 °F (600 °C) upon entering the convection section, the stack measurement may become less representative of the flue gas exiting the radiant section. The rate of CO afterburning increases with higher convection section temperatures.

When using a laser based technology for CO control, methane and hydrogen will not be detected. Current laser based technology will not simultaneously detect multiple combustibles in a single laser beam. Hydrogen cannot be detected with laser technology. If desired, methane will require an independent measurement.

3.2.4.4.2 CEMS Systems

A CO specific measurement is sometimes used to satisfy a regulatory requirement. When CO is measured as a regulatory requirement it is reported on a dry basis and is independent of analytical measurements for process control. As part of the CEMS, the CO analyzer utilizes the CEMS sample system and reporting mechanism according to federal and state regulations and permit requirements. For CEMS systems, the CO analyzer is based on infrared technology and is unaffected by the presence of other flue gases such as unburned hydrocarbons, CO₂, or hydrogen. Extractive or in-situ systems can be used for CO measurement.

- Extractive systems require a sample probe, sample line, and sample conditioning system with chillers to remove moisture to provide a dry basis measurement.
- An in-situ analyzer requires access to the point of insertion. Note that if an in-situ analyzer is allowed, a satisfactory determination of the stack gas water content must be attained for dry basis correlation, typically by a grab sample and lab analysis during stack testing. For infrared based in-situ CEMS systems, moisture content may be measured directly.

3.2.4.5 Sulfur Oxides (SO_x)

Sulfur oxide analyzers, specifically sulfur dioxide measurement, may be required by regulatory agencies. With a common fuel gas header, sulfur in the fuel gas is typically measured at the fuel gas drum outlet with associated flow measurements as an alternative to installing analyzers on every heater stack.

If stack emission monitoring is required by the regulatory agency, the type of analyzer is dependent upon the agency's requirements. Monitoring and reporting SO_x on a dry basis is achieved by the use of an extractive sample conditioning system to remove the water component. Extractive type is preferred to remove as much moisture as possible, due to the solubility of low SO₂ concentrations in the water. Note that if an in-situ SO_x analyzer is allowed, a satisfactory determination of the stack gas water content must be attained for dry basis correlation, typically by a grab sample and lab analysis during stack testing. The majority of SO_x analyzers used in flue gas analysis are based upon ultraviolet or infrared technology.

3.2.4.6 Nitrogen Oxides (NO_x)

Nitrogen oxide measurement is often required by regulatory agencies. Refer to API 535 for graphs showing the relationship of NO_x to excess oxygen, firebox temperature, combustion air temperature and hydrogen content in the fuel gas.

If stack emission monitoring is required by the regulatory agency, the type of analyzer is dependent upon the requirements of the agency. Monitoring and reporting NO_x on a dry basis is achieved by the use of an extractive sample conditioning system to remove the water component. Note that if an in-situ analyzer is allowed, a satisfactory determination of the stack gas water content must be attained for dry basis correlation, typically by grab sample and lab analysis during stack testing. The majority of NO_x analyzers used in flue gas analysis are based upon chemiluminescence, ultraviolet or infrared technology.

3.2.5 Fuel Gas Heating Value

For small variations in fuel gas composition and heating value, oxygen trim control may be effective.

Where variations in fuel gas composition and heating value impact combustion control, it is recommended to compensate the fuel gas flow measurement (see 3.2.3.1). With a negligible amount of inert compounds in the fuel

gas, a change in heating value may be inferred from a change in fuel gas density (e.g. mass flow measurement or gas density analyzer).

With a varying amount of inert compounds in the fuel gas (e.g. carbon dioxide or nitrogen) and where wide variations in heating value may adversely impact combustion control, a Wobbe Index meter or Heat of Combustion meter is recommended. This measurement is generally made on the plant fuel gas system rather than at individual heaters. Calorimeters and gas chromatographs provide direct analytical measurements for determining the heating value. Gas chromatographs and calorimeters are complex and require more maintenance than densitometers; however, density measurements are not suitable for inferring the heating value of the fuel gas when significant and variable concentrations of inert gases are present in the fuel gas.

Typical fuel gas heating value analysis response times are as follows:

- fast response heating value analyzer (Residual Oxygen Measurement)—5 seconds to 90 % response;
- heating value transmitter (Thermopile)—45 seconds to 99 % response;
- gas chromatographs—3 minutes to 5 minutes.

3.2.6 Flame Monitoring

Flame monitoring in refinery heater applications with complex heaters having multiple burners and variable fuel characteristics has resulted in varied experiences with performance and reliability. There are many design and installation details to be resolved prior to considering the use of flame monitors.

Flame monitoring may be used to detect loss of flame at one or more burners. Factors to be considered when implementing a flame monitoring system include:

- burner design,
- number of burners,
- types of fuels burned,
- types of fuels burned simultaneously,
- fuel composition variations,
- heater geometry,
- quantity and type of process safety layers of protection.

3.2.6.1 Flame Monitoring Application Design

Where flame monitoring is considered, the following items may impact the location, number, and orientation of monitors.

- Ability to monitor pilot flame only, if desired, when main burners are in service.
- Ability to monitor main burner flame only when continuous duty pilots are in use. The pilot flame shall not be permitted to falsely indicate the presence of main flame.
- Number of burners, geometry of firebox and ability to discriminate between burners.

- Luminosity of flame and background radiation in firebox.
- Flame shape over the full range of fired heater load, fuel mix, and burner load.
- Potential interference from flames on other burners.
- The potential for a need to adjust sighting to achieve adequate detection and discrimination.
- Ability to distinguish between the monitored flame versus other radiation sources.
- Ability to distinguish individual flames during multiple burner operation.
- Resistance to external energy sources such as gamma radiation and X-ray radiation.
- Fail safe operation.
- Redundancy as required for reliability.

3.2.6.2 Flame Monitor Technologies

Flame ionization rod technology directly contacts the flame to monitor ions. Flame scanners detect differences between the flame and the surroundings (other burners and combustion chamber). The flame ionization rod requires period replacement while the flame scanner requires a continuous utility for purging. Intelligent video recognition of flames, although not common in the refining industry, should be considered to minimize operator visual inspections at the heater.

3.2.6.2.1 Flame Ionization Rods

The following considerations apply to flame ionization rods.

- The flame ionization rod is consumable requiring periodic replacement.
- The flame ionization rod is generally used only to detect the pilot flame.
- The highest quality flame rod may not last long if used in the main flame.

3.2.6.2.2 Flame scanners

Depending on the type of fuel used, flame scanners may be purchased as:

- infrared (IR) flame scanners,
- ultraviolet (UV) flame scanners,
- simultaneous UV/IR flame scanners.

IR detection is not recommended for fuel gas as it will generally responds to background refractory changes. Strength of signal is better from UV detectors when firing fuel gas. Combination (IR/UV) may be recommended to improve reliability.

The ability to discriminate flame within a burner may be an application issue. For example, with a staged fuel gas burner, the flame scanner may detect the presence of flames from the primary tips and not be able to detect loss of flame at the secondary gas tips.

With a large number of burners, establishing flame scanner trip voting logic can be difficult to resolve.

Flame scanners require self-checking diagnostics to reduce the probability of false flame indication.

Before using flame scanners consideration should be given to the following: maintenance issues, variations in flame color, fuel gas composition and heating value, burner plugging (flame pattern), intensity fluctuations, and flame sighting difficulty.

3.2.6.3 Flame Monitoring Application Design—Installation

The following items should be considered for flame detector installations.

- Flame ionization rod installation should consider metallurgy, ease of removal (on-line or not), potential for electrical shorting, maximum operating temperature, and the recommendations of the pilot burner and flame rod manufacturers.
- Flame scanners.
 - Mounting flame scanners on the burner base plate for vertically upfired burners or across the firebox are both options. Vertical installation must account for debris settling on the detector and difficulty of burner tip cleaning due to mechanical interference of the scanner with the burner. Sighting through the firebox must consider the distance between the flame and the monitor and the tube layout that may obscure the flame.
 - The flame scanner mounting base should be designed with a swivel mount so that the flame scanning angle can be adjusted.
 - The sighting tube in flame scanners should be air purged to keep the detector clean, the detector temperature within safe limits, and the sight path free of dust or other particulates. The detector should be located to minimize dust, other particulates or moisture obstructions on the sensor lens or sight glass.
 - Local radiographing of plant piping can trigger shutdowns on self-checking UV scanners.
 - Care should be taken to follow the manufacturer's recommendation for cable type and distance requirements. Cable should not be routed with any high voltage wiring used for igniters (if provided).
 - For improved system integrity, flame scanners with dynamic self-checking features are required.

Although all refinery instrumentation should be installed with back up power via uninterruptible power supply (UPS) it is worth mentioning that flame monitor power should be from UPS as these devices generally cannot be powered directly from the control system or shutdown system.

3.2.6.4 Other Design Considerations

Additional design consideration should be given to the following items.

- Some designs utilize pilot flame detection as a permissive to allow fuel gas valves to open.
- Where applicable, arrangements of voting for trip may be applied, such as loss of 2 out of 6 burners, or where any two adjacent burners fail.
- Integration with optional automated shutoff valves on individual burners such as when a burner management system is applied.

3.3 Process Control

The primary purpose of the process control system is to automatically maintain safe, environmentally compliant, stable operation and meet the required heater duty.

3.3.1 Controlling Heater Firing

Outlet process temperature is typically used for controlling heater firing.

- This control is often a temperature to fuel gas flow cascade control, and provides for constant output temperature set point selection. High and/or low burner pressure overrides may be added to the fuel gas flow controller. To smooth the transition between controllers, the unselected controller should include anti-reset windup or output tracking.
- An alternate is to use fuel gas pressure cascade control, thus allowing both low and high pressure constraints to be configured. These constraints on fuel gas pressure to the burner not only protect against hazards, but also aid to minimize trips where low and high pressure shutdown set points are configured. Control of fuel gas pressure also provides more stable operation when load changes occur.

The two cascade modes respond very differently when adding or removing burners.

- When adding (or removing) burners with the temperature-to-flow cascade, the flow controller will redistribute the fuel gas to the burners in service resulting in a decrease (or increase) in burner pressure.
- When adding (or removing) burners with the temperature-to-pressure cascade, the pressure controller will maintain burner pressure to the burners in service resulting in an increase (or decrease) in fuel gas flow.

Starting the heater on temperature-to-pressure cascade and then switching to temperature-to-flow cascade once a set firebox or process outlet temperature is reached is an option.

When the control valve has sufficient turndown to light the first burner at startup, considerations to maintain the desired light off pressure may include:

- a low pressure setpoint limit in the fuel gas controller,
- a minimum flow soft stop in a smart valve positioner at the fuel gas control valve,
- a minimum flow mechanical stop at the fuel gas control valve.

When the control valve lacks sufficient turndown to light the first burner at startup, alternate considerations to maintain the desired light off pressure may include a minimum flow orifice or a minimum fire regulator. Each startup device is typically sized to light the first few burners until the control valve is within control range. Each must be installed in parallel with the fuel gas control valve. Neither is permitted to bypass the safety shutoff valves.

Additional considerations when using a minimum fire regulator are as follows.

- A minimum fire regulator may be placed in continuous service to prevent a low pressure trip if the fuel gas control valve moves to its fully closed position. However, refinery fuel gas is corrosive and startup regulators are typically blocked in after startup to protect the regulator.
- Improper installation of a minimum fire regulator may prevent a normal heater startup. Symptoms include reduced flow capacity and/or pressure control instability. Reduced capacity will carry fewer burners yielding a trip on low pressure when flow demand exceeds flow capacity. Adjusting the control spring with pressure control instability may cause the regulator to open too quickly yielding a trip on high pressure.

- Regulator sensing taps should not be installed in areas of flow and pressure instability such as piping elbows. Consult vendor technical references for proper installation.
- For minimum fire regulators, it is desirable that the pressure drop is negligible between the regulator sensing tap and the tap(s) for the burner pressure transmitter(s) to the safety system. Otherwise, response time may be insufficient to prevent a trip.

If the fuel gas supply pressure can exceed the maximum allowable burner pressure for premix burners (stable flame with no impingement with minimum oxygen), a fuel gas pressure regulator or controller should be used to limit the fuel gas supply pressure in order to prevent over-firing and flameout. Many raw gas burner designs do not have this high pressure limitation.

3.3.2 Charge Flow Controls

Charge flow controls are applied for each of the following cases.

- Total flow control is used for non-coking process streams where pass balancing is not required.
- Individual pass flow control is used when symmetrical piping is insufficient to distribute the flow evenly in the heater passes. It is used when processing vaporizing streams and when coking is a possibility. Pass balancing is used to minimize the possibility of coking on a heater pass by adjusting flows.
- Two phase flow cannot be measured reliably therefore the liquid and vapor phase flows should be individually controlled for each pass.
- Designing pass flow control valves to fail open and applying soft limits (constraints) or hard stops to prevent valve closure aids in preventing tube damage or coking due to inadvertent valve closure.

3.3.3 Air/Fuel Ratio Control

Failure to properly control the air/fuel ratio can lead to flame impingement, afterburning, flameout, or an explosion.

- Sufficient oxygen must be available at all times to assure complete combustion and safe operating conditions (i.e. a well defined flame with no flame impingement) even with fluctuations in fuel composition. Continuous measurement of the oxygen and combustibles content in the flue gas provides a guide for adjusting the fuel/air ratio.
- Air/fuel ratio control can be improved if combustion air flow measurement is available.
- A typical method for controlling fuel gas and air flow in a forced-draft heater is shown in Figure 1. In this typical cross-limiting combustion control system, fuel flow and air flow are controlled in parallel with the control signals interconnected through signal selectors so that excess air is always maintained during load changes. The combined action of the signal selectors causes the air to lead the fuel on increasing load changes and the air to lag the fuel on decreasing load changes.

A typical method for controlling fuel gas combustion in a natural-draft fired heater is shown in Figure 2 (i.e. process outlet temperature cascade to fuel gas flow control). Another method involves controlling the inlet air dampers to maintain the proper oxygen values and using the stack damper to control the draft.

- When an oxygen analyzer is used for trim control, output limits at the oxygen controller or setpoint limits at the air or air/fuel ratio controller should be implemented. Should the oxygen analyzer malfunction high, this limit prevents the oxygen controller from driving the heater into an unacceptably low oxygen condition.

3.3.4 Firebox Draft Control

Where applicable, a fired heater draft control system is recommended to maintain the firebox draft within its desired operating range.

- For forced or natural draft heaters the firebox draft should be controlled by the stack damper as shown in Figure 3. For induced-draft or balanced draft heaters, the firebox draft may also be controlled by the induced-draft fan damper or the induced draft fan's speed.

If a combustion air preheater, induced-draft fan damper or induced-draft fan malfunction occur, or if the combustion air preheater is taken out of service, the draft control must be switched, either automatically or manually. When the induced draft fan is not operating, open its bypass damper if the heater is configured to operate in natural draft mode. Use the stack damper to control draft. When the air preheater is not operating, open its bypass damper(s) if the heater is configured to operate in natural draft mode. If the heater is not configured to operate in natural draft mode or the flue gas system has a selective catalytic reduction (SCR) module, a likely option may be to shutdown the heater to stay within environmental regulation limits.

- In the event that the draft transmitter malfunctions to create a low draft (high firebox pressure) condition, a low oxygen override may be considered as an independent action to open the stack damper or reduce the firing rate. The rate of change of the override controller should be adjusted such that a process step change may be detected within the overall response time of the control loop. For example, an oxygen analyzer located at the top of the radiant section may have an inherent process delay on the order of 60 seconds to 90 seconds to T90.

3.4 Protective Systems

The purpose of protective systems is to maintain safe operation or to achieve safe state in response to unacceptable process deviations.

Protective actions include the following.

- Basic Process Control System (BPCS) Action—control overrides independent of the initiating cause.
- Operator Action—operator response to alarms, including emergency response.
- SIS Action—startup permissives and interlocks, close safety shutoff valves, open dampers.

Protective functions include the following components.

- Input Devices—process measurements (e.g. analytical sensors, analog transmitters, or discrete switches), manual input devices (e.g. hard or soft hand switches/pushbuttons), and status indications (e.g. position transmitters or limit switches).
- Logic Solver—programmable electronic systems, hardwired relays, solid state systems.
- Output Devices—solenoid or relay interface to final elements (e.g. safety shutoff valves, combustion air dampers, stack damper, or natural draft dropout doors), and alarm/status indicators (e.g. panel lights, or Human Machine Interface (HMI) display graphics).

The diversity in the design of fired heaters requires that each heater be independently evaluated to ensure that each hazard scenario is effectively mitigated. Since each heater may have unique features or operational modes, it is critically important that those responsible for assessing the availability and reliability of a protective function understand all of the possible equipment failure modes and the potential impact to the operating unit and personnel.

Typical Process Instrumentation and Protective Instrumentation Functions

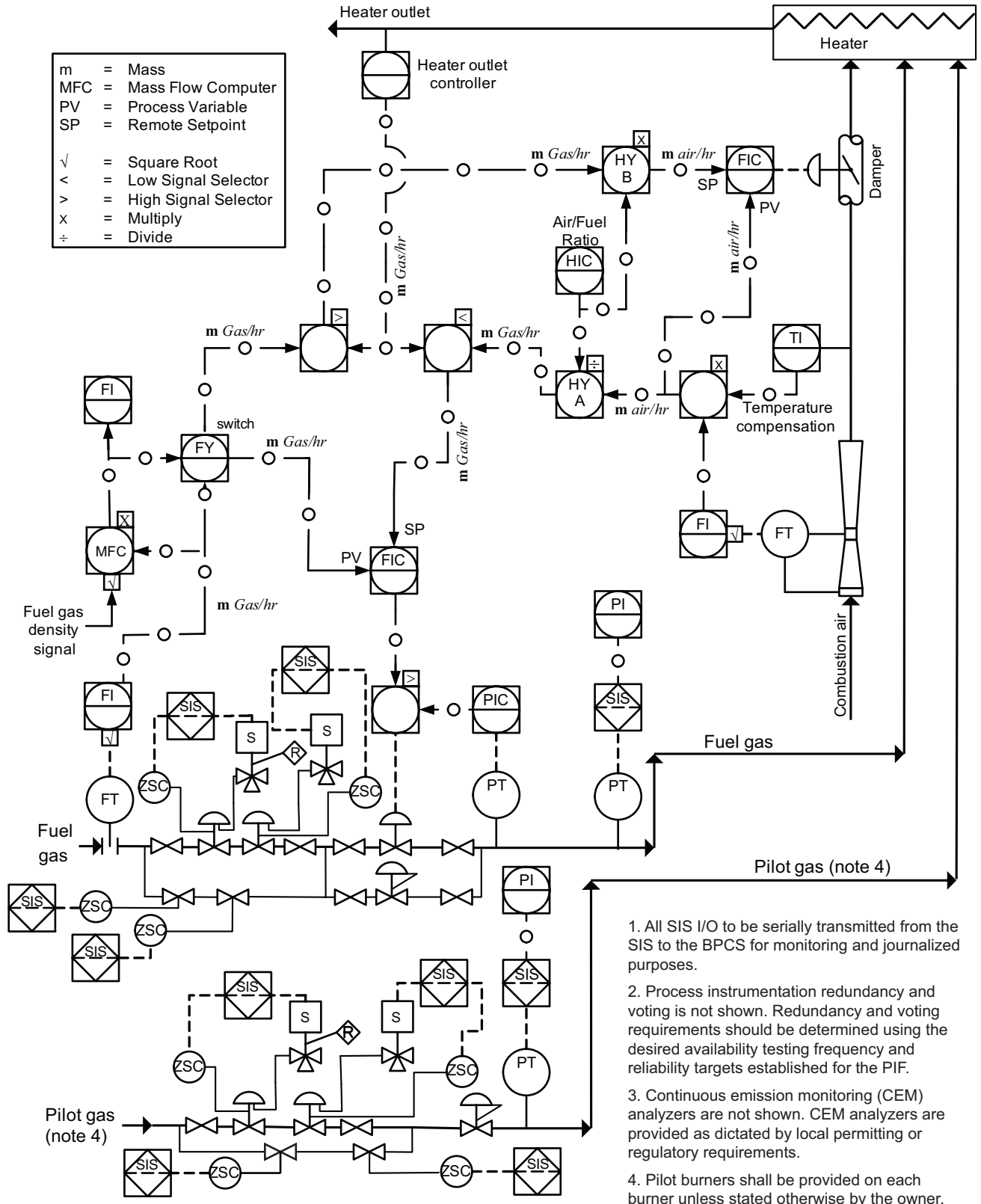

Figure 1—Forced Draft Fired Heater—Fuel Side

Typical Process Instrumentation and Protective Instrumentation Functions

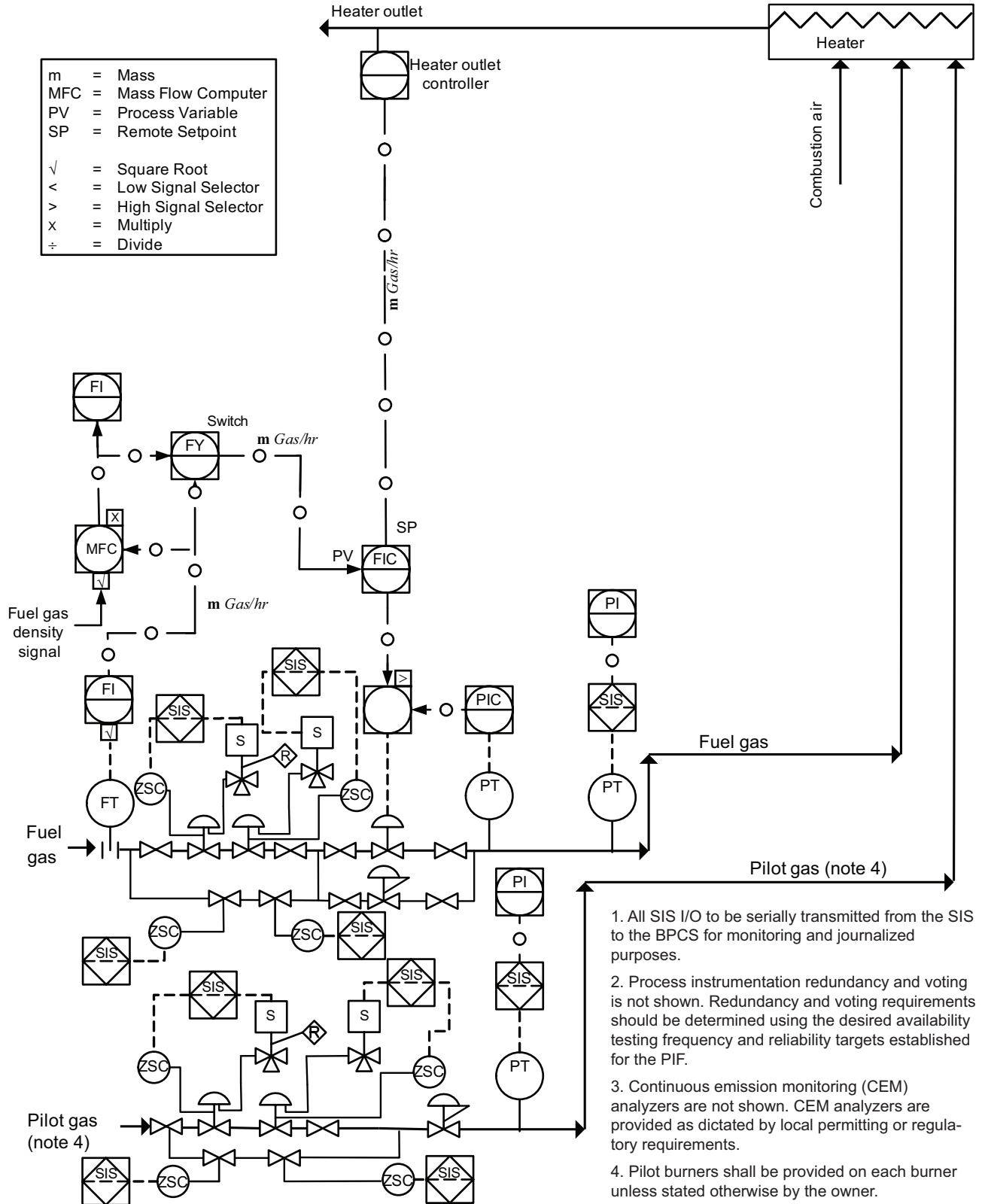
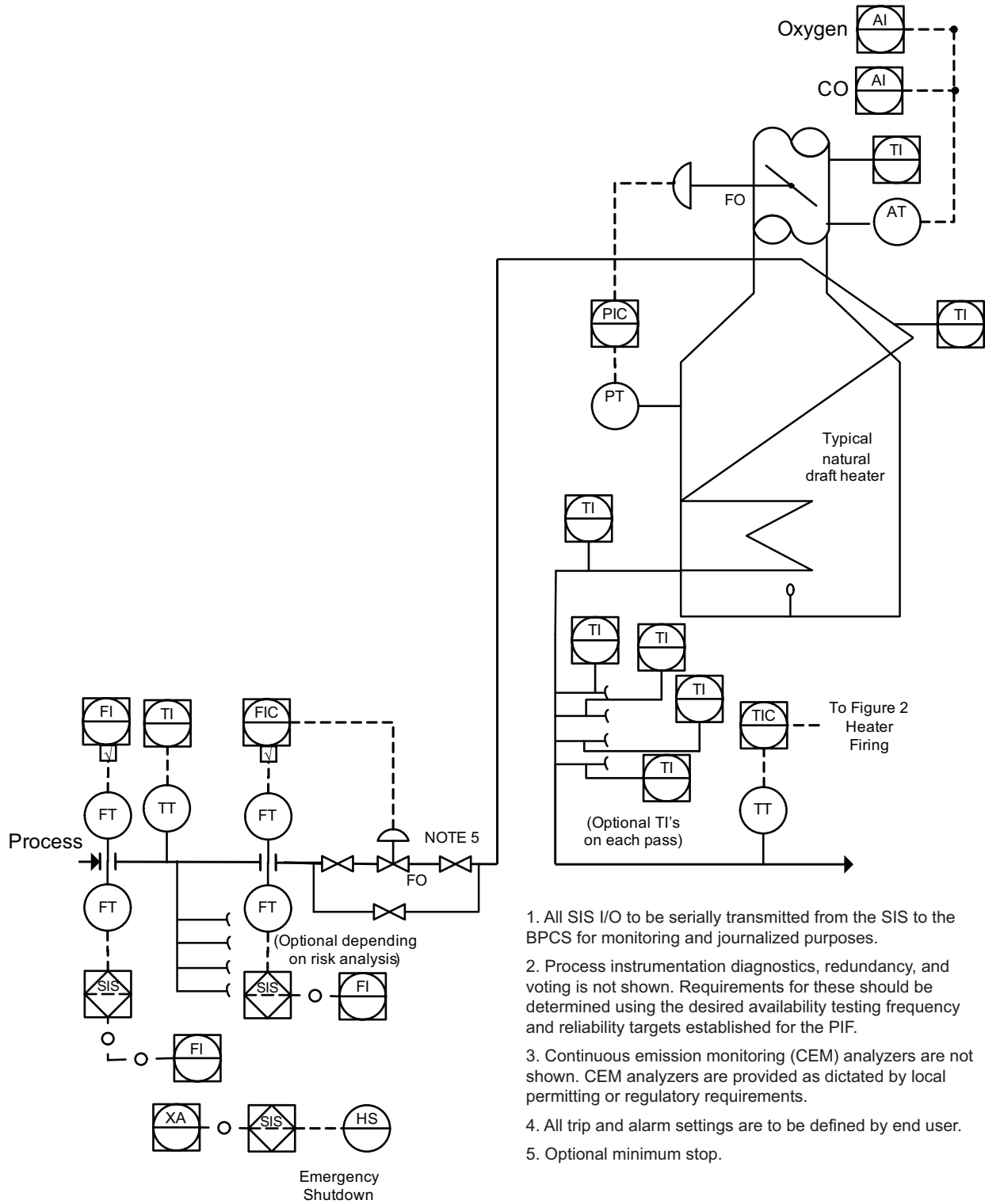

Figure 2—Natural Draft Fired Heater—Fuel Side

Typical Process Instrumentation and Protective Instrumentation Functions



1. All SIS I/O to be serially transmitted from the SIS to the BPCS for monitoring and journalized purposes.
2. Process instrumentation diagnostics, redundancy, and voting is not shown. Requirements for these should be determined using the desired availability testing frequency and reliability targets established for the PIF.
3. Continuous emission monitoring (CEM) analyzers are not shown. CEM analyzers are provided as dictated by local permitting or regulatory requirements.
4. All trip and alarm settings are to be defined by end user.
5. Optional minimum stop.

Figure 3—Natural Draft Fired Heater—Process Side

The diversity of issues that may impact the protective function requirements include:

- type of process, operating temperature and pressure;
- type and size of the heater;
- type and number of burners;
- type and reliability of the pilots;
- turndown requirements;
- operating and safety criteria from the burner manufacturer;
- variability in fuel gas composition and supply pressure;
- fuel supply reliability and filtration requirements;
- length and cross sectional area of air ducts (velocity, turbulence, flow conditioning);
- mechanical integrity of combustion air and flue gas dampers;
- location of taps for process measurement;
- line size and pressure drop in the fuel gas manifold to the burners;
- redundancy requirements for availability and reliability;
- scheduled outage or turnaround intervals.

Additional considerations for protective functions include the following.

- **Operational Modes**—Consideration must be given to all equipment modes of operation (e.g. start-up, process change, minimum firing, and shutdown operations) to ensure there is adequate protection in all of these modes. Conditions such as sulfiding, hydrogen sweep, decoking, spalling, catalyst regeneration, and switching from forced to natural draft operations are examples of process change operations.
- **Independence**—It is recommended practice to maintain separation between the control and protective systems. For example, a control device that malfunctions to create an unacceptable process deviation is no longer available to detect or mitigate the process hazard it has created.
- **Loss of Utility**—When loss of electrical power or instrument air occurs, it is essential the final elements are designed to fail safe. For example, solenoids should be de-energized to trip and the springs in the safety shutoff valves should fail in the direction required to achieve safe state.
- **Reliable Power Source**—It is recommended that all protective instrumentation be sourced from a reliable power source, e.g. uninterruptible power supply (UPS) per API 554.
- **System Reset**—Once activated, the SIS should keep the process in the safe state until the unsafe condition is corrected and the SIS is manually reset.
- **Event Logging**—It is recommended that protective systems be implemented with alarm/logging systems capable of capturing first out and sequence of events alarms.

A protective instrumented function (PIF) may be applied to the process side (tube) and the combustion side of heaters. PIFs are implemented to detect hazardous conditions and either achieve or maintain a safe state. When a PIF is implemented to prevent a hazardous event that could result in personnel injury or fatality, the PIF is classified as a safety instrumented function (SIF).

A SIF assigned a safety integrity level (SIL) of 1, 2, 3, or 4 shall comply with the requirements of ANSI/ISA 84.00.01-2004 (IEC-61511 MOD). Although this standard is accepted good engineering practice and is recommended for the protection of personnel and the environment, the work process may be applied to asset protection. While these PIFs may have an assigned integrity level (IL) they should be clearly identified as non-safety applications.

3.4.1 Response Time Considerations

Each protective function has a maximum permissible time for corrective action to mitigate a hazardous event.

3.4.1.1 Process Safety Time

Process safety time is the interval between the initiating event leading to an unacceptable process deviation and the hazardous event.

3.4.1.2 Process Response Time

Process response time (dead time, delay time, or lag time) is the time required for a process variable to start changing after an initiating event.

For example, the extent of a change in the air/fuel ratio may not be fully detectable by an oxygen analyzer for several tens of seconds even if the oxygen measurement at the top of the firebox is instantaneous.

There may also be process response time between corrective action to safe state and the time at which safe state is achieved.

3.4.1.3 Measurement Lag Time

Measurement lag time is the time required for an instrument to provide feedback to the control or safety system in response to a change in a process variable.

Measurement lag times are typically associated with temperature and analytical measurements.

The response times for analytical measurements are frequently represented as a percent of final value to a process step change. For example, $T_{90} < 10$ seconds represents a sensor response to 90 % final value of the process deviation in less than 10 seconds.

3.4.1.4 Time Delays

Input time delays are frequently implemented to minimize trips caused by transient conditions that do not create a process hazard. Due to the fast scan capability of PLC's and other logic solvers, small variations, or short term process impulses may be detected which may yield a trip when hazardous conditions are not present. Therefore, an input time delay of 0.5 seconds to 1.0 second is frequently implemented as an input filter.

Delay trip timers may be used to confirm the presence of a hazardous condition for a sustained period prior to activating a trip; however, a thorough knowledge of the process safety time and time to safe state is required.

3.4.1.5 Time to Safe State

Time to safe state is the time difference between alarm or trip setpoint activation and the time required to achieve a safe state. Setpoints should be selected to detect the unacceptable process deviation as early as possible in the process hazard timeline. For a protective function to be effective, safe state must be achieved within the process safety time.

- For operator response to an alarm, this includes diagnosis time, field travel time, corrective action time, and the process response time to achieve safe state.
- For an automated protective function, this includes delay trip timers in the logic solver, stroke time for safety shutoff valve(s) or dampers, and the process response time to achieve safe state.

3.4.1.6 Operator Response to Alarms

Alarms may be configured to notify the operator of abnormal process conditions, allowing the operator to take corrective action prior to an automated response by the safety shutdown system.

- The basis for alarm setpoints, the correct operator actions in response to the alarms, and the response time requirements to safe state should be documented during the design phase. Alarms that do not have a clear operator response should be avoided. It is important to identify which alarms require immediate response to assign them an appropriate priority. The operator response to each alarm should be defined in the process unit's operating procedures.

See 3.4.8 and Table 1 for the summary of alarms.

3.4.2 Overrides and Limits

A startup override is an automated bypass of a startup trip condition that is automatically enabled in the startup sequence when the trip condition is no longer present. If protective functions must be temporarily overridden to start up a heater, visual indication and/or alarm that the protective function is overridden should be provided to the operator. It is recommended that devices which are automatically overridden by the logic (even though manually initiated) be automatically returned to service (latched or activated) when the startup trip condition is cleared. It is recommended that startup overrides are designed as part of the logic to avoid inadvertently leaving a startup bypass active after startup.

- As an example, a startup override of the low fuel gas burner pressure trip is typically required to permit opening of the fuel gas block valves. Otherwise, the low pressure condition at startup below the trip setpoint would not allow the block valves to be sequenced open. Once the burner pressure is confirmed above the low pressure trip setpoint for a fixed time interval, the logic solver will typically activate the low pressure protective function.
- Startup override alarm and status indications should be provided to the operator interface.

A control override does not bypass a protective function. Instead, a control override is designed to keep the heater within operational limits and prevent a trip (where applicable). A control override permits one controller to take control of the signal output from another controller. The output from two or more controllers is typically combined into a high or low selector, and the output from the selector controls the signal output to the final element.

- As an example, if the fuel gas controller is in temperature-to-flow cascade. A fuel gas pressure controller may be configured to monitor the burner pressure. At the low (or high) setpoint limit, the pressure controller may override the flow controller to keep the heater in a safe operating region and prevent a trip on low (or high) burner pressure. Once the burner pressure is within the setpoint limits of the pressure controller, control is automatically returned to the flow controller via the high or low selector.
- Consider a counter to track how frequently a control override is invoked.

A setpoint or output limit(s) are configurable options at the controller to keep the heater within operational limits and prevent a trip (where applicable).

- As an example, if the fuel gas controller is in temperature-to-pressure cascade, limits may be configured in the pressure controller to prevent a trip on low (or high) burner pressure. Although generally referred to as a control override, the controller output is not externally controlled via a high or low selector. Instead, a soft clamp is configured into the controller.
- Setpoint or output limits are not typically annunciated at the operator interface.

3.4.3 Bypasses and Permissives

A bypass refers to a manually initiated action to bypass the input device(s) of a protective function and typically involves a keyed bypass or other manual initiation. A protective function that is bypassed is not available to trip until the bypass is manually removed and the protective function is returned to service.

- During normal operation, bypassing an input measurement device temporarily for maintenance, calibration, and testing is permissible where governed by trained personnel, applicable maintenance and operating procedures, and any emergency response procedures relevant to the measurement under bypass. The associated control system alarm for the measured process variable cannot be bypassed at the same time as the protective device.
- Bypass alarm and status indications should be provided to the operator interface.
- It is recommended that a startup bypass is managed via a startup override.

Permissives are conditions which must be satisfied to progress to the next step in a sequence.

- As an example, fuel gas header pressure above a minimum light off pressure may be a permissive to open the pilot gas and/or fuel gas safety shutoff valves. Once the sequence has progressed to the next step, a permissive does not typically trip. For example, fuel gas header pressure (not burner pressure) may fall below permissive limits with no trip action once the pilots and/or burners are in service. At this point in the sequence, low fuel gas header pressure would typically alarm only.
- The status of permissives is typically indicated at the operator interface.

3.4.4 Process Hazards Protection

Recommended protective functions for process hazards related to fired heaters are provided below. These protective functions consist of a measurement and an action, usually operating valves, dampers, or motors. Each process deviation lists the process hazard, considerations, control overrides, alarms, and protective functions.

In each case, consideration should be given in regards to the redundancy required, both from an availability and reliability perspective. Accessibility to maintain and test on-line should also be reviewed. For redundant process measurements, process tap locations and potential for common mode failure due to plugging or compromised measurement should be evaluated.

3.4.4.1 Accumulation of Combustibles within the Firebox (Loss of Flame, Substoichiometric Combustion, or Tube Leaks)

3.4.4.1.1 Process Hazards

Loss of flame, substoichiometric combustion or tube leaks may lead to the accumulation of combustibles within the fired heater.

Potential hazardous events include:

- afterburning in the radiant, convection, or stack sections which may result in the overheating and failure of tubes, tube supports and/or refractory systems;
- an explosion which may result in the partial or total destruction of the fired heater and which may be hazardous to personnel in the operating area.

These hazardous events may develop if the following occur:

- combustible material accumulates in the fired heater;
- oxygen is either present prior to the accumulation of combustible materials or oxygen is reintroduced after the accumulation of combustible materials;
- sufficient time passes to allow the combustible material and oxygen to meet and mix and thereby reach a flammable mixture condition;
- the flammable mixture is either hot enough to auto ignite or it encounters an ignition source such as a section of hot refractory, a heated analyzer sensor/cell, an operating pilot, or an operating burner.

3.4.4.1.2 Considerations

Additional design consideration should be given to the following items. See Annex A for further discussion on tube rupture.

- a) The hazard associated with a specific concentration of combustibles in the firebox mixing with fresh air and igniting may be estimated using thermodynamic calculations. The severity level posed by such an event depends on the amount of energy released as pressure⁸.
- b) At startup conditions, the accumulation of combustibles within the firebox should not be permitted to exceed 25% of the lower explosion limit (LEL) before corrective action is initiated. The LEL may be calculated at laboratory conditions using Le Chatelier's formula and LEL data for pure components as listed in NFPA 325, *Guide to Fire Hazard Properties of Flammable Liquids, Gases, and Volatile Solids*, 1994 edition.
- c) At operating conditions, it is possible for a heater to accumulate combustibles at firebox temperatures above the auto-ignition temperature if there is insufficient air to consume all of the fuel. Fuel-rich combustion produces hot flue gas with residual combustibles that can explode if mixed with fresh air too quickly. This is most likely to occur when a furnace transitions suddenly from rich combustion to lean combustion⁹.
- d) Process deviations that precede flameout are typically associated with operational limits. Approaching or exceeding operational limits can lead to rapid accumulation of combustibles within the firebox. For example, loss of flame may result in the rapid accumulation of combustibles to an unacceptable hazard level in less than 10 seconds. Process deviations that precede flame out include:
 - low fuel gas burner pressure (see 3.4.4.2);
 - high fuel gas burner pressure (see 3.4.4.3);
 - low combustion air flow (see 3.4.4.4);
 - failure of dropout doors to open (see 3.4.4.5);

⁸ Hawryluk, A., "Hazardous Flue Gas Mixtures in Furnaces Due to Fuel-Rich Combustion", Ethylene Producers Conference, 8 Apr 2008.

⁹ Hawryluk, A., *ibid.*

- low draft (high firebox pressure) (see 3.4.4.6);
 - failure of stack damper to open (see 3.4.4.7);
 - rapid change in fuel gas composition with uncompensated fuel flow (see 3.2.3.1);
 - slug of liquid in fuel gas system that causes loss of flame.
- e) Process deviations that occur within operational limits may lead to substoichiometric combustion and a gradual accumulation of combustibles within the firebox. These process deviations include:
- a small hydrogen and/or hydrocarbon tube leak into the firebox;
 - an increase in fuel gas flow rate to the burners without a corresponding increase in combustion air flow rate to the burners;
 - a decrease in a combustion air flow rate or flue gas damper position in automatic control, (e.g. due to the malfunction high of an oxygen analyzer or the failure of a draft transmitter) without a corresponding decrease in fuel gas flow to the burners;
 - burner tip plugging in one or more burners;
 - partially closing a block valve on a fuel gas line to an individual burner in a multi-burner heater;
 - partially or fully closing the air register to an individual burner in a multi-burner heater;
 - changes in ambient conditions;
 - changes in fuel gas composition;
 - a reduction in firebox temperature (see 3.4.4.8);
- f) Excessively fuel lean combustion with low firebox temperature may lead to gradual accumulation of combustibles within the firebox.

3.4.4.1.3 Control Overrides

Consider the following additional control overrides to keep the heater within operational limits and prevent a trip (where applicable).

- Low fuel gas burner pressure override to the fuel gas controller (see 3.4.4.2).
 - High fuel gas burner pressure override to the fuel gas controller (see 3.4.4.3).
 - Reduce firing rate to established turndown condition during transition from balanced or forced draft to natural draft (see 3.4.4.5).
 - Low draft (high firebox pressure) override (see 3.4.4.6).
 - Low oxygen override to the fuel gas controller (see 3.4.4.9).
 - High combustibles override.
- a) For forced or balanced draft heaters, the combustibles measurement may be used as a control override to increase combustion air flow if combustibles levels are below a specified threshold, typically 500 ppm. Above that specified threshold, fuel gas flow should be reduced before combustion air flow is increased.

- b) For natural draft heaters, the combustibles measurement may be used as an override to the fuel gas controller to reduce fuel gas flow if combustibles levels are above a specified threshold.
- A design consideration is to adjust the rate of change of the controller output to the fuel gas control valve or stack damper such that a process step change may be detected within the overall response time of the control loop. For example, an oxygen analyzer located at the top of the radiant section may have an inherent process delay on the order of 60 seconds to 90 seconds to T90.
- To be effective, control overrides should:
 - a) be independent of the initiating cause (e.g. control loop malfunction) of the hazard scenario;
 - b) operate continuously in response to the process deviation creating the hazard scenario.

3.4.4.1.4 Alarms

Multiple alarms may be used to assist the operators. These alarms come in two different categories.

- a) Alarms may be set to alert operators of abnormal process conditions that are approaching operational limits which may lead to flameout and the rapid accumulation of combustibles within the firebox. The alarms may be triggered by the following:
 - low fuel gas burner pressure (see 3.4.4.2);
 - high fuel gas burner pressure (see 3.4.4.3);
 - low combustion air flow (see 3.4.4.4);
 - low draft (high firebox pressure) (see 3.4.4.6);
 - low firebox temperature (see 3.4.4.8);
 - high liquid level in an upstream fuel gas drum.
- b) Alarms may be set to alert operators to abnormal process conditions that occur within operational limits which may lead to substoichiometric combustion and a gradual accumulation of combustibles within the firebox. The alarms may be triggered by the following:
 - low oxygen (see 3.4.4.9);
 - high CO/combustibles;
 - partial loss of flame (loss of one or more burners with sufficient heat release and air from the online burners to sustain combustion in the firebox);
 - flooding alarm (a drop in process outlet coil temperature with an associated increase in firing rate when in temperature cascade mode).

3.4.4.1.5 Protective Functions

Multiple protective functions may be used to mitigate the process hazards associated with accumulation of combustibles in the firebox. These protective functions are in two different categories.

- a) To mitigate process deviations at operational limits that precede flameout, close the fuel gas shutoff valves in response to:
- low fuel gas burner pressure (see 3.4.4.2);
 - high fuel gas burner pressure (where applicable, see 3.4.4.3);
 - low combustion air flow (where applicable, see 3.4.4.4);
 - failure of dropout doors to open (where applicable, see 3.4.4.5);
 - low draft (high firebox pressure) (where applicable, see 3.4.4.6);
 - failure of stack damper to open (where applicable, see 3.4.4.7);
 - high liquid level in an upstream fuel gas drum (optional).

NOTE The basis for tripping in response to process deviations that precede flameout is to prevent a rapid accumulation scenario. Once a rapid accumulation event is initiated, it may be challenging to achieve safe state within the process safety time.

- b) Consider the following options in response to process deviations that occur within operational limits which may lead to substoichiometric combustion and a gradual accumulation of combustibles within the firebox.

Option 1: Operator Response to a Fuel Rich Environment—This is the traditional option for refinery process heaters where operators are trained to recognize the signs of substoichiometric combustion such as:

- alarms,
- a huffing sound associated with pressure pulsations in the furnace,
- elevated convection section or stack temperatures due to afterburning,
- smoke in flue gas leaving the stack,
- smell of unburned fuel.

As long as combustion is sustained, operators should clear the area of personnel and slowly reduce fuel gas flow to avoid a hazardous situation. For example, if an operator responds to a fuel-rich furnace by completely shutting off the fuel then fresh air will mix with the combustibles inside the firebox and may ignite. Even a sudden change from 90 % air to 110 % air (10 % excess air) could be too much for the furnace to follow safely. An understanding of the residence time is helpful to establish a safe ramp rate¹⁰.

Potential advantage—This option reduces the number of times a fired heater is shutdown in response to substoichiometric combustion. Some facilities have operating experience to indicate that heater explosions are more likely to occur during light off, due to inadequate purge or delayed ignition, than during substoichiometric combustion¹¹. For those facilities, reducing the number of restarts may be an important consideration.

¹⁰ Hawryluk, A., *ibid.*

¹¹ Ostroot, G. (1972), "Explosions in gas- or oil-fired furnaces", *Loss Prevention*, 6, 112

Potential disadvantage—The sequence of events may progress more quickly, from substoichiometric combustion to majority loss of flame, than the operator can effectively manage. Upon loss of flame the operator should close the fuel gas shutoff valves. Additional considerations in a fuel rich environment include the following.

- For heaters with automated snuffing steam valves or snuffing steam valves located a safe distance away from the heater, introduce snuffing steam into the firebox in conjunction with closing the fuel gas shutoff valves. With steam as a motive force, consider reducing combustion air flow or stopping the forced draft (FD) fan (where applicable).
- For balanced draft heaters, take into consideration that air preheaters are often corroded. To avoid a fire in the air preheater, consider shutting down the ID fan and partially open the stack damper.
- Consider removing potential ignition sources (e.g. continuous pilots and the analyzer sensor power).

Option 2: Automated response prior to accumulating a hazardous gas mixture—Close the fuel gas shutoff valves at the onset of combustibles breakthrough using conventional combination oxygen/combustibles analyzers or laser based technology.

- Oxygen Analyzer (ZrO_2)—90 % final response to a step change in flue gas composition is typically achieved in less than 10 seconds.
- Combustibles Analyzer (Catalytic Bead)—90 % final response to a step change in flue gas composition is typically achieved within 20 seconds to 25 seconds.
- Laser based technology is capable of detecting oxygen or CO with 100 % final response to a step change in flue gas composition within 5 seconds.

Potential Advantage—For the gradual accumulation case, this option provides an opportunity to take corrective action to safe state early in the process hazard timeline. Some facilities have operating experience to indicate that heater explosions are more likely to occur as a result of improper response to a fuel-rich environment than during light off. For those facilities, reducing the likelihood of accumulating a hazardous gas mixture may be an important consideration.

Potential Disadvantage—If a gradual accumulation event progresses too quickly, the analyzers may be incapable of detecting a hazardous gas mixture prior to reaching hazardous levels. Thus, limiting controller ramp rate(s) such that a process step change may be detected within the overall response time of the control loop, and maintaining sufficient operating margin between oxygen setpoint and combustibles breakthrough, are important considerations.

NOTE Ideally, the basis for selecting analytical trip setpoints at the onset of combustibles breakthrough (e.g. 1200 ppm to 1500 ppm CO) is to mitigate the accumulation of a hazardous gas mixture prior to loss of flame. However, a gradual accumulation event must have sufficient process delay to facilitate detection of residual combustibles from fuel-rich combustion prior to reaching hazardous levels. In practice, the detection of low oxygen and/or high combustibles prior to loss of flame may be impacted by:

- Inherent process delay to achieve a representative sample at the sensor's location (e.g. at the top of radiant section).
- Measurement delay due to sensor response—Typical published T90 specifications from catalytic bead and film sensors can range from < 20 seconds to 30 seconds. These manufacturer specifications often do not define the concentration step change at which the T90 applies which may have a significant impact on T90 response (typically longer T90 times for lower concentration step changes). Analytical sensor test data may indicate the true T90 response time to a concentration step change of 0 ppm to 1000 ppm and 1000 ppm to 5000 ppm CO may be > 2 minutes. The true response time of the sensor may be determined by performing tests outlined in 3.2.4.1.

Option 3: Automated response upon Loss of Flame—Close the fuel gas shutoff valves upon loss of flame at one or more burners detected using flame scanners. Flame scanners have a configurable delay off timer that is typically configured from 0 seconds to 4 seconds maximum to the logic solver.

Potential Advantage—This option provides the fastest response time to detect of loss of flame at one or more burners.

Potential Disadvantage—Complexity and reliability. As the number of burners is increased, resolving the correct trip voting logic can be a complex problem to resolve at different firing rates. For example, loss of a few burners at high firing rates may permit sustained combustion at higher firebox temperatures, but the same may not be true at lower firing rates. Additionally, flame scanners can be costly in relation to other protection layers and may present problems with sighting and discrimination between multiple burners.

3.4.4.2 Low Fuel Gas Burner Pressure

3.4.4.2.1 Process Hazard

Fuel gas burner pressure below that required for stable flame operation may lead to the accumulation of combustibles within the fired heater. See 3.4.4.1 for a description of the hazardous events that may occur.

3.4.4.2.2 Considerations

There are multiple considerations related to low fuel gas pressure.

- a) The low pressure trip setpoint should be determined based on burner test data for the expected range of fuel gas compositions, combustion air temperatures, firebox temperatures and air/fuel ratios. Alternatively, the low pressure trip setting may be based on the burner manufacturer's heat release curve.
 - Premix burners may flameout at pressures below 3 psi(g) [0.2 kg/cm²(g)].
 - Raw gas, low and ultra low NO_x type burners may operate to pressures as low as 0.5 psi(g) [0.035 kg/cm²(g)].
 - The actual pressures vary with the fuel composition and burner design.
- b) Startup mode has a higher probability of creating the process hazard associated with low fuel gas burner pressure. To improve conditions for safe light off of the first few burners, see 3.3.1.
- c) Throttling gas cocks should be avoided. It effectively defeats the low pressure trip and increases the probability of creating the stated process hazard.
- d) Without continuous pilots, an input time delay on the order of 0.5 seconds may be acceptable in order to minimize the number of trips caused by a transient drop in fuel gas pressure below the low fuel gas pressure trip setpoint. At low firing rate conditions, there may be barely enough heat in the tile or other components to relight the burners once they flame out. Re-ignition may not occur if burner components are allowed to cool for more than 0.5 seconds.
- e) With continuous pilots, a delay trip timer on the order of 3 seconds to 5 seconds may be acceptable in order to minimize the number of trips caused by a momentary drop in fuel gas pressure below the low fuel gas pressure trip setpoint. Additionally, the delay trip timer should be short enough that pilots relight the burners without causing a significant pressure wave inside the firebox.

3.4.4.2.3 Control Overrides

Consider implementing a low fuel gas burner pressure override to the fuel gas pressure controller to keep the heater within operational limits and prevent a trip (where applicable). This may be accomplished by configuring an output or setpoint limit in the fuel gas pressure controller or a low pressure override to the fuel gas flow controller.

3.4.4.2.4 Alarm

Low fuel gas burner pressure should be alarmed to alert operators prior to a trip of the fuel gas shutoff valves.

3.4.4.2.5 Protective Functions

There are multiple protective functions related to low fuel gas pressure.

- a) The fuel gas shutoff valves shall be closed at the low fuel gas pressure trip setpoint.
- b) The low fuel gas burner pressure trip setpoint shall be set to precede flameout (see 3.4.4.1.2).
- c) For burners with independent fuel gas supplies, each supply shall be independently tripped at the respective low pressure trip setpoint. Since the air/fuel ratio will increase when such a shutdown occurs, details of how the burner will perform when suddenly subjected to high excess air should be provided by the burner vendor or determined by prior burner testing.
- d) When automatic trip of the main fuel gas safety shutoff valves occur, all waste fuels that require main fuel gas firing for stability shall also be automatically tripped.

3.4.4.3 High Fuel Gas Burner Pressure

3.4.4.3.1 Process Hazards

Fuel gas burner pressure above that required for stable flame operation may lead to the accumulation of combustibles within the fired heater. High fuel gas burner pressure may also lead to flame impingement on one or more tubes. See 3.4.4.1 and 3.4.4.14 for a description of the hazardous events that may occur.

3.4.4.3.2 Considerations

The high pressure trip setpoint should be determined based on burner test data for the expected range of fuel gas compositions, combustion air temperatures, firebox temperatures and air/fuel ratios. Alternatively, the high pressure trip setting may be based on the burner manufacturer's heat release curve.

Pilots do not typically provide additional protection to mitigate loss of flame due to high burner pressure. The pilot is intended to light the main burner at startup conditions (reduced fire heat release and reduced air flow). Most pilots for process heaters are Class 3 igniters (< 4 % of the burner's maximum heat release) and are designed to light the burner at minimum fire conditions only. Few pilots are Class 2 igniters (4 % to 10 % of the burner's maximum heat release) and are designed to light the burner at minimum fire conditions with incremental light off support beyond minimum fire as the ignition energy is increased toward 10 %, approaching that of a Class 1 igniter. Consult with the burner manufacturer for additional information.

3.4.4.3.3 Control Overrides

Consider implementing one of the following:

- a) A high fuel gas burner pressure override to the fuel gas controller to keep the heater within operational limits and prevent a trip (where applicable). This may be accomplished by configuring an output or setpoint limit in the fuel gas pressure controller or a high pressure override to the fuel gas flow controller.
- b) The BPCS may reduce firing rate to minimum fire to keep the heater within operational limits and prevent a trip (where applicable). For those heaters without continuous pilots, this provides a hot restart capability at minimum fire.

3.4.4.3.4 Alarms

High fuel gas burner pressure should be alarmed to alert operators prior to a trip of the fuel gas shutoff valves.

3.4.4.3.5 Protective Functions

There are multiple protective functions related to high fuel gas pressure.

- a) The fuel gas shutoff valves should be closed at the high fuel gas pressure trip setpoint. Alternate techniques for mitigating high fuel gas burner pressure may include:
 - using an upstream fuel gas header pressure controller with a high pressure limit;
 - maximum travel stop on the fuel gas pressure control valve.
- b) The high fuel gas burner pressure trip setpoint shall be set to precede flameout (see 3.4.4.1.2).
- c) For burners with independent fuel gas supplies, each supply shall be independently tripped at the respective high pressure trip setpoint. Since the air/fuel ratio will increase when such a shutdown occurs, details of how the burner will perform when suddenly subjected to high excess air should be provided by the burner vendor or determined by prior burner testing.
- d) When automatic trip of the main fuel gas safety shutoff valves occur, all waste fuels that require main fuel gas firing for stability shall also be automatically tripped.

3.4.4.4 Low Combustion Air Flow

3.4.4.4.1 Process hazard

Combustion air flow below that needed for stable flame operation may lead to the accumulation of combustibles within the fired heater. See 3.4.4.1 for a description of the hazardous events that may occur.

3.4.4.4.2 Considerations

Additional design consideration should be given to the following items.

- a) Combustion air flow monitoring is not normally carried out on natural draft heaters. This section is intended to apply to fired heaters equipped with forced draft fans.
- b) If the protective function is configured to allow different modes of operation, the low combustion air flow alarm and trip setpoints for the two most frequently considered modes of operation may be set as follows:
 - Startup Operation—Below the combustion air flow required with all burners operating at their minimum fired heat release.
 - Normal Operation—Below the combustion air flow required at turndown conditions with some additional margin to account for measurement instability.
- c) Where air flow measurement is not practical for existing air duct designs, air duct pressure measurement is an option downstream of dampers and preheaters (see 3.2.2.1).
- d) Monitoring forced draft fan motor run status, motor power, or motor amps is frequently used as a leading indicator for loss of combustion air. Response time is improved by taking corrective action on loss of fan instead of waiting for the low flow trip setpoint.

- e) Many process heaters equipped with combustion air preheat cannot operate at full rate when switching from balanced to natural draft unless the burners and fresh air system are sized for the full rate during natural draft operation.

3.4.4.4.3 Control Overrides

To keep the heater within operational limits and prevent a trip (where applicable), consider implementing:

- Air/fuel ratio cross-limiting controls (see 3.3.3).
- A low oxygen override to the fuel gas controller (see 3.4.4.9). This may be accomplished by reducing the fuel gas firing rate at low oxygen conditions to keep the flue gas above the minimum desired oxygen concentration.

3.4.4.4.4 Alarms

The following alarms should be included to alert operators prior to a trip of the fuel gas shutoff valves:

- low combustion air flow,
- low air duct pressure (if measured),
- loss of forced draft fan,
- low forced draft fan speed (if measured),
- high fan vibration (if measured),
- high motor amps (if measured),
- high and low differential pressure across the forced draft fan (if measured).

3.4.4.4.5 Protective Functions

The following protective functions are associated with combustion air process hazard mitigation.

- a) One of the following shall occur at the low combustion air flow trip setpoint:

Option 1—The fuel gas shutoff valves shall be closed.

Option 2—Dropout door(s) in the combustion air ductwork shall open.

- The doors shall open within an allowable time frame (see 3.4.4.5).
- Firing rate should be automatically reduced (as required) to a predetermined natural draft mode setting.

- b) The low combustion air flow trip setpoint shall be set to precede flameout (see 3.4.4.1.2).

- c) In installations with air preheaters (especially balanced draft), it may be necessary to bypass the preheater (trip the ID fan and open the stack damper) to prevent damaging the air preheater.

3.4.4.5 Failure of Dropout Doors to Open

3.4.4.5.1 Process Hazard

Failure of dropout doors to open upon loss of FD fan or low combustion air flow may lead to the accumulation of combustibles within the fired heater. See 3.4.4.1 for a description of the hazardous events that may occur.

3.4.4.5.2 Considerations

Additional design consideration should be given to the following items.

- a) For loss of FD fan, motor run status is frequently used as a leading indicator on the process hazard timeline so that corrective action to safe state (e.g. opening of dropout doors) may be achieved within the process safety time. Run status will yield more reaction time to transition the combustion air source to natural draft via dropout doors.
- b) Opening the doors/damper more than 70° rotation does not provide significant additional air flow. Therefore, it is not mandatory to confirm the air doors are 100 % open (e.g. via limit switch) but that they have opened sufficiently (e.g. via position transmitter) to allow the necessary air flow into the heater.

3.4.4.5.3 Control Overrides

Consider implementing a reduced firing rate to established turndown condition during transition from balanced or forced draft to natural draft to keep the heater within operational limits and prevent a trip (where applicable).

3.4.4.5.4 Alarms

Alarms should be included for closed and open position deviations from the commanded position of each dropout door.

3.4.4.5.5 Protective Functions

Upon loss of FD fan or low combustion air flow, the dropout doors may be opened to provide an alternate source of combustion air. If the dropout doors fail to open within the allowable time frame (typically within 5 seconds to 10 seconds) the fuel gas shutoff valves shall be closed.

3.4.4.6 Low/High Draft (High/Low Firebox Pressure)

3.4.4.6.1 Process Hazards

For natural draft and induced draft fired heaters, low draft or positive pressure can create a condition where insufficient combustion air is delivered to the burners. High draft can create a condition where too much air is delivered to the burners and combustion is quenched. Either condition may lead to the accumulation of combustibles within the fired heater. See 3.4.4.1 for a description of the hazardous events that may occur.

Additional hazards for positive pressure include:

- personnel exposure to hot flue gas that may flow out of openings in the firebox and/or view ports;
- backflow of flames through burner air registers and/or flames exiting the firebox through open view ports.

Additional hazards for high draft include elongation of flames leading to flame impingement and/or afterburning in the radiant, convection, or stack sections which may result in the overheating and failure of refractory systems, tube supports and/or tubes.

Instantaneous structural integrity issues are not typically considered as credible process hazards for low or high draft conditions. However, long term operation at positive pressure can result in flue gas acid attack and/or high temperature exposure causing structural damage to the fired heater's shell and/or structural steel.

3.4.4.6.2 Considerations

Additional design consideration should be given to the following items.

- a) See 3.2.2.1 for a definition of draft and pressure terms as used in this document.
- b) For induced and natural draft heaters, combustion air flow is not typically measured but may be inferred from the draft measurement. For these types of heaters, a low draft (high firebox pressure) condition has the potential to yield loss of flame by preventing a sufficient supply of combustion air into the burner(s). A low draft alarm should therefore be installed to alert operators of the potential lack of combustion air. In the case of natural draft heaters, tripping fuel gas supply to the heater should be considered for ultra-low NO_x burners with known flame stability issues. There are instances where the development of sufficiently positive pressure inside the firebox has caused flow reversal. The need for such a trip and the setpoint should be determined during burner testing.
- c) For forced draft heaters, low draft (high firebox pressure) trip is optional when the forced draft fan is operating and combustion air flow is measured directly with a flow transmitter.
- d) A low draft (high firebox pressure) trip is not required when using premix burners with capability to self-inspire sufficient combustion air for maintaining flame stability.
- e) For forced draft and natural draft fired heaters, a stack damper minimum stop or an annular gap around the damper is used to avoid a condition where the damper is fully closed and potentially stuck closed. For natural draft heaters, this also minimizes the potential for reaching a low draft (positive pressure) condition. The minimum stop setting depends on fuel, heater type, stack diameter and type of damper.
 - Typical constraints are in the 10 % to 25 % range.
 - The constraint can be configured in the control system, applied as a hard minimum stop at the damper or by physically trimming off some of the damper blade. Care must be taken to ensure damper balance is not negatively impacted.
- f) Monitoring induced draft fan motor run status, motor power, or motor amps is frequently used as a leading indicator of loss of draft. Response time is improved by taking corrective action on loss of fan instead of waiting for the low draft (high firebox pressure) trip setpoint (where applicable).

3.4.4.6.3 Control Overrides

For forced draft and natural draft heaters, consider implementing overrides for low draft (high firebox pressure) in the following order to keep the heater within operational limits and prevent a trip (where applicable):

- partially open stack damper;
- decrease fuel gas controller.

For induced draft heaters, consider implementing overrides for low draft (high firebox pressure) in the following order to keep the heater within operational limits and prevent a trip (where applicable):

- partially open inlet draft damper (single speed fan) or increase fan speed [when equipped with variable frequency drive (VFD)];
- partially open stack damper;
- decrease fuel gas controller.

3.4.4.6.4 Alarms

Multiple alarms may be used to assist the operators.

- a) A low draft (high firebox pressure) alarm at the arch of approximately zero inches of water column is recommended to alert personnel of potential hot flue gas and/or flame escaping from the heater.
- b) A high draft alarm is recommended for one or more of the following situations:
 - Alert operators to an operating condition that can result in excessive tramp air entering the heater through leaks in the casing.
 - When a low draft (high firebox pressure) trip is implemented (see 3.2.2.1 for information on the draft/combustion air flow relationship).
 - For natural, balanced or induced draft heaters when there is a concern that an increase in draft, without a corresponding decrease in burner register settings, can result in a combustion air flow rate high enough to create flame instability.
- c) Due to a potential for difficulty in measurement (i.e. noisy signals) and/or control (i.e. damper condition or tuning), a 1 second to 3 second time delay filter configured in the BPCS or safety system (not at the transmitter) may be considered for both low draft and high draft alarms.
- d) For induced draft heaters, the following alarms are recommended:
 - loss of induced draft fan;
 - low induced draft fan speed (if measured);
 - high and low differential pressure across the induced draft fan (if measured);
 - high induced draft fan inlet temperature.

3.4.4.6.5 Protective Functions

Upon loss of ID fan or low draft (high firebox pressure), for balanced or induced draft mode, the stack damper may be opened to relieve high firebox pressure. If either the stack damper fails to open or the firebox pressure is not relieved within time constraints (see 3.4.4.7) the fuel gas shutoff valves shall be closed.

For natural draft mode, the fuel gas shutoff valves should be closed where a low draft (high firebox pressure) condition is likely to yield loss of flame due to insufficient draft of combustion air or backflow of flue gas into the plenum. The trip setpoint should be set to precede flameout.

3.4.4.7 Failure of Stack Damper to Open

3.4.4.7.1 Process Hazard

For heaters operating in induced draft mode, failure of the stack damper to open upon loss of the induced draft fan will result in high firebox pressure (see 3.4.4.6).

3.4.4.7.2 Considerations

Additional design consideration should be given to the following items.

- a) Loss of flame, due to insufficient draft of combustion air or backflow of flue gas into the plenum, may result in the rapid accumulation of combustibles to an unacceptable hazard level in less than 10 seconds. To permit corrective action within the available process safety time, the stack damper should be opened as quickly as possible and verified open within 5 seconds to 10 seconds. Additional consideration may be required to slow the rotation of large damper assemblies to keep the force applied at travel stops from damaging heater components. For example, a restriction orifice may be installed on the solenoid vent to slow damper rotation.
- b) Monitoring induced draft fan motor run status, motor power, or motor amps is frequently used as a leading indicator for loss of draft. Response time is improved by taking corrective action on loss of fan instead of waiting for the low draft (high firebox pressure) trip setpoint (where applicable).
- c) Opening the stack damper more than 70° rotation does not provide significant additional flue gas flow. Therefore, it is not mandatory to confirm the stack damper is 100 % open (e.g. via limit switch) but that it has opened sufficiently (e.g. via position transmitter) to allow the necessary flue gas flow out of the heater.

3.4.4.7.3 Alarms

When the stack damper is modulating, a position transmitter may provide a diagnostic alarm for early indication that the stack damper is sticking. This is typically implemented by comparing commanded position to feedback position within 5 seconds to 10 seconds.

3.4.4.7.4 Protective Functions

Upon loss of ID fan or low draft (high firebox pressure), the stack damper may be opened to relieve the pressure. If either the stack damper fails to open or the firebox pressure is not relieved within time constraints, the fuel gas shutoff valves shall be closed.

3.4.4.8 Firebox and Stack Temperature

3.4.4.8.1 Process Hazards

Multiple process hazards are associated with firebox and stack temperature.

- a) A high bridgwall temperature may indicate overall over firing, localized over firing, individual burner related issues, process changes, etc. Operating with a high bridgwall temperature may eventually lead to decreased reliability.
- b) A low radiant floor flue gas temperature may lead to an unstable flame condition in some radiant floor mounted, low NO_x burners with internally recirculated flue gas, especially at low flue gas oxygen levels.
- c) A high stack flue gas temperature is indication of potential over firing, reduced convection section heat transfer, leaking heater tubes, afterburning, or a fire.
- d) Although not a process hazard, a low stack flue gas temperature indicates abnormal operation and the potential for condensing acid corrosion in the stack over long periods of time.

3.4.4.8.2 Considerations

Although not a process hazard, a low stack temperature indicates the potential for:

- incomplete combustion,
- corrosion of unlined stack,
- ammonium sulfate/bisulfate salt formation on the selective catalytic reduction catalyst,
- damaging analyzer sensors/cells,
- condensation and salt formation in sampling lines,
- pitting and unbalancing ID fan blades,
- fouling and corrosion of air pre-heater elements,
- fouling and pitting of cold process tubes in the convection section,
- stack damper corrosion,
- acid condensing on nearby equipment,
- visible plume formation.

A high stack temperature indicates potential for:

- stack damper failure (oxidation, thermal expansion and/or warping);
- mechanical failure of stack;
- weakening of unlined structure at top of the convection section;
- overheating of air preheater elements;
- overheating of induced draft fan;
- sintering of selective catalytic reduction (SCR) catalyst.

3.4.4.8.3 Alarms

Multiple alarms may be used to assist the operators.

- a) A high bridgeway temperature alarm is recommended.
- b) For ultra-low NO_x burner applications where flame stability performance is a concern, consider a low bridgeway temperature and/or low floor temperature alarm.
- c) A high temperature alarm is recommended above the convection section in the stack to warn against high stack flue gas temperature.
- d) A low stack flue gas temperature trend display should be considered to warn of acid dew point condensation. An alarm could be configured to alert the operator if this condition exists for a longer period of time.

3.4.4.8.4 Protective Functions

No protective functions are recommended.

3.4.4.9 Low Oxygen

3.4.4.9.1 Process Hazard

Low oxygen in the flue gas may be an indication that combustion air flow is below that needed for stable flame operation, which in turn may lead to the accumulation of combustibles within the fired heater. See 3.4.4.1 for a description of the hazardous events that may occur.

3.4.4.9.2 Considerations

Additional design consideration should be given to the following items.

- a) Combustibles breakthrough testing is recommended to establish oxygen concentration when combustibles breakthrough occurs. Combustibles breakthrough typically occurs between 0.5 % to 2.5 % oxygen depending on tramp air flow rate, condition of the burners, fuel gas composition and bridgewall temperature.
- b) The operating margin between the %O₂ setpoint and breakthrough must be sufficient to allow a process step change to be detected within the overall response time of the control loop (see 3.4.4.1.3).
- c) Heaters should be operated at a %O₂ setpoint that provides sufficient operating margin above combustibles breakthrough to accommodate anticipated changes in fuel gas composition.
- d) The safe operating margin for %O₂ above combustibles breakthrough is directly related to the control infrastructure. For example, many natural draft heaters with manually controlled stack dampers (no draft control) have been operated safely for many years at 3 %O₂ (i.e. at least 2 %O₂ above the breakthrough point).
- e) The following issues should be considered, especially when reducing the operating margin to less than 2 % between %O₂ setpoint and combustibles breakthrough.
 - Process safety time calculated or tested within reasonable accuracy to define the response time requirements for protective controls.
 - Any additional requirements for accuracy, turndown, and repeatability in measurement and final control elements to keep the heater in a safe operating region.
 - Limits of protective instrumentation to effectively respond within the available process safety time, e.g. the oxygen analyzer response time to a process step change (see 3.2.4.2).
 - Inaccuracy or variability in draft and firing controls, and the potential impact of a sudden drop in O₂ levels due to a control loop malfunction.
 - Emergency response procedures to a control loop malfunction or operator error which could result in insufficient combustion air (low O₂), flameout, and the rapid accumulation of unburned fuel gas in the heater.
- f) In a properly designed system with fast response infrared or lased based O₂/CO measurements, oxygen control at less than 1 % may be acceptable (see 3.2.4.4). The final control elements (e.g. stack dampers, automated burner registers and/or combustion air dampers) must have sufficient accuracy, turndown and repeatability to keep the heater in a safe operating region.

3.4.4.9.3 Control Overrides

Consider implementing a low oxygen override to the fuel gas controller to keep the heater within operational limits and prevent a trip (where applicable). This may be accomplished by reducing the fuel gas firing rate at low oxygen conditions to keep the flue gas above the minimum desired oxygen concentration.

When an oxygen analyzer is used for trim control, output limits at the oxygen controller or setpoint limits at the air or air/fuel ratio controller should be implemented. Should the oxygen analyzer malfunction high, this limit prevents the oxygen controller from driving the heater into an unacceptably low oxygen condition. To keep the heater within operational limits, the oxygen trim controller should not be permitted to change the air flow more than the operating margin between %O₂ setpoint and combustibles breakthrough. For example, where the operating margin between %O₂ setpoint and combustibles breakthrough has been selected at 2 %, the oxygen trim controller should not change the air flow by more than 10 % (i.e. where 1 %O₂ is estimated at 5 % excess air).

3.4.4.9.4 Alarms

A low oxygen alarm is recommended to alert personnel of a potential low combustion air flow situation.

Once flameout at one or more burners occurs, the oxygen indication will eventually rise. At this point, a low oxygen alarm is ineffective at detecting combustion problems.

3.4.4.9.5 Protective Functions

No protective functions are recommended.

3.4.4.10 Low Pilot Gas Pressure

3.4.4.10.1 Process Hazard

Low pilot gas pressure is a process hazard when in use without main burner operation (e.g. during start up, refractory dry out periods, or after a main fuel gas trip with continuous pilots). In pilot only mode, pilot gas pressure below that needed for stable flame operation may lead to the accumulation of combustibles within the fired heater. See 3.4.4.1 for a description of the hazardous events that may occur.

3.4.4.10.2 Considerations

Additional design consideration should be given to the following items.

- a) When pilots are used, they should be monitored visually or electronically to ensure high availability. When loss of pilot flame is detected, the unlit pilot should be immediately isolated or relit to prevent an accumulation of unburned pilot gas into the firebox in the event of a main fuel gas trip.
- b) Pilots often have a limited operating range of fuel composition. Firing a pilot gas fuel out of the recommended range can cause the pilot to become unstable, to blow out or to flash back. High hydrogen content or low pilot burner gas pressures may cause flashback and backfiring.
- c) When pilots are used, the pilot gas should be reliable and clean. To reduce the potential of common mode failure for low fuel gas header pressure to both pilots and burners, it is recommended to separately source the pilots upstream of the fuel gas controller and safety shutoff valves to the main burners. Since refinery gas often contains inert gases, amines, corrosion products, salts or other particulates which can cause plugging of the pilot burners, consider an independent source of pipeline natural gas or purchase gas.

- d) To reduce the potential for common cause failure for low combustion air to the pilots and main burners, a frequent consideration is to locate the pilot's air inspirator fully external to the heater; however, this should not be done at the expense of pilot flame stability or reliability.
- e) The pilot is intended to light the main burner at startup conditions (minimum fire heat release and minimum air flow). In general, pilots are neither designed nor intended to provide main burner flame stability.

3.4.4.10.3 Alarms

The pilot gas low pressure alarm should be set above the minimum pressure required to maintain a stable pilot flame.

3.4.4.10.4 Protective Functions

An automatic trip of the pilot gas shutoff valves is recommended if the pilot gas pressure decreases below that required for a stable flame. This is especially important during pilot only operation, when main burners are not in use.

3.4.4.11 High Pilot Gas Pressure

3.4.4.11.1 Process Hazard

High pilot gas pressure is a process hazard when in use without main burner operation (e.g. during start up, refractory dry out periods, or after a main fuel gas trip with continuous pilots). In pilot only mode, pilot gas pressure above that needed for stable flame operation may lead to the accumulation of combustibles within the fired heater. See 3.4.4.1 for a description of the hazardous events that may occur.

3.4.4.11.2 Considerations

Additional design consideration should be given to the following items.

- a) When pilots are used, they should be monitored visually or electronically to ensure high availability. When loss of pilot flame is detected, the unlit pilot should be immediately isolated or relit to prevent an accumulation of unburned pilot gas into the firebox in the event of a trip to main fuel gas.
- b) Pilots often have a limited operating range of fuel composition. Firing a pilot gas fuel out of the recommended range can cause the pilot to become unstable, to blow out or to flash back.
- c) When pilots are used, the pilot gas should be clean and reliable. Since refinery gas often contain inert gases, amines, corrosion products, salts or other particulates which can cause plugging of the pilot burners, consider an independent source of pipeline natural gas or purchase gas.
- d) To reduce the potential for common cause failure for low combustion air to the pilots and main burners, a frequent consideration is to locate the pilot's air inspirator fully external to the heater; however, this should not be done at the expense of pilot flame stability or reliability.
- e) As pilots are primarily premix burners, they are susceptible to flame lift off at gas pressures above vendor recommended levels. The lift off pressure is a function of the gas composition, tip drilling and orifice size.

3.4.4.11.3 Alarms

The pilot gas high pressure alarm should be set below the maximum pressure required to maintain a stable pilot flame.

3.4.4.11.4 Protective Functions

An automatic trip of the pilot gas shutoff valves is recommended if the pilot gas pressure increases above that required for a stable flame. This is especially important during pilot only operation, when main burners are not in use.

3.4.4.12 Low Charge or Feed Flow

3.4.4.12.1 Process Hazard

A low process flow may cause overheating in the heater tubes. This will hasten coking (in coking type services) and shorten tube life or cause tube failure.

3.4.4.12.2 Considerations

Additional design consideration should be given to the following items.

- a) Waste Heat Services (e.g. steam generation or boiler feed water economizers) that are specifically designed (or a design review has been conducted) for operation without flow do not need low process flow alarms or shutdowns.
- b) For multi-cell heaters, with common equipment (e.g. shared convection section), it may be necessary to trip fuel gas to all cells on low process flow in one service.
- c) Minimum flow constraints (mechanical, soft stop in valve positioner, or controller setpoint or output limits) are frequently considered for pass flow control valves. Minimum flow mechanical stops reduce the frequency of no flow conditions from pass flow control loop failures.
- d) When flow reaches a point where accelerated coking will occur or the tubes are in danger of considerable damage heat must be reduced. An alternative in some services is to inject steam into the coil on low pass flow. For some high fouling services, such as coker units, low pass flow can result in the coking of the heater tubes. The user must consider whether steam should automatically be injected at low process flow to maintain a minimum velocity to avoid coking.

3.4.4.12.3 Control Overrides

Consider an override to reduce the firing rate in response to a singular low pass flow condition. Alternatively, consider an override to reduce the firing rate to minimum firing. The basis is to minimize tube damage during a low process flow event.

An alternative, in some services, is to inject sufficient steam into the coil (see 3.3.2) to maintain velocity and keep it cool, in response to a low process flow alarm.

3.4.4.12.4 Alarms

A low flow alarm is recommended on the total feed to the heater where flow through each pass is not measured.

On parallel-pass heaters in coking services, individual pass flow controls with individual, low flow alarms are recommended for each pass.

For hydroprocessing or similar applications where hydrogen and oil are measured separately, evaluation should be conducted for each application for low flow hydrogen or oil. An alarm should be considered for each individual flow meter.

3.4.4.12.5 Protective Functions

The following protective functions are associated with low charge or feed flow hazard mitigation.

- a) A low charge flow on the total feed to the heater should cause a main fuel gas trip or minimum firing operation where flow through each pass is not measured and pass plugging is minimal.
- b) A low charge flow on any individual pass should cause a main fuel gas trip or minimum firing operation for parallel-pass heaters which have individual pass flow controls and a high opportunity for coking or plugging.
- c) Loss of charge flow (e.g. loss of charge pump) should cause a main fuel gas trip. An exception is permissible for heaters with process tubes designed to sustain minimum fire heat release at zero process flow. In this case, a low fire shutdown (minimum fire operation) may be specified in lieu of a main fuel gas shutdown.

3.4.4.13 High Process Outlet Temperature

3.4.4.13.1 Process Hazards

This condition can result in shortened tube life from over firing, off spec process operations, potential coking for certain types of processes, overheating of transfer lines and indicates improper heating to coil flow ratios.

3.4.4.13.2 Considerations

Additional design consideration should be given to the following items.

- a) A process outlet temperature measurement is not effective for detecting loss of charge flow. Thus, minimum flow constraints (mechanical, soft stop in valve positioner, or controller setpoint or output limits) are frequently considered for pass flow control valves. Minimum flow mechanical stops reduce the frequency of no flow conditions from pass flow control loop failures.
- b) Where each pass has its own flow controller, an individual pass flow transmitter may malfunction high, masking the low flow alarm, to close the pass flow control valve to its minimum flow mechanical stop (where applicable). This will yield a high process outlet temperature at low flow on the individual pass.
- c) Ideally, all heaters should be controlled by balancing the pass flows. Using temperature cascade to individual pass flow control valves may not be advisable for some coking services. The possible sequence of undesirable events is as follows:
 - 1) coke deposits in a pass,
 - 2) heat transfer to the pass is inhibited,
 - 3) the pass outlet temperature decreases,
 - 4) the temperature controller responds by reducing flow to the pass,
 - 5) the resulting increase in oil residence time in the pass and the resulting decrease in shear stress at the tube wall accelerates the rate of coke formation in that pass.

A similar sequence of undesirable events can occur if the individual pass outlet thermowell is insulated by coke deposits.

3.4.4.13.3 Control Overrides

A combined outlet process temperature is typically used to control heater firing. However, for multi-pass heaters with flow control on individual passes, consider an override to reduce the firing rate in response to a singular high outlet pass temperature. Alternatively, consider an override to reduce the firing rate to minimum firing. The basis is to protect an individual tube when a flow controller malfunctions to close a control valve to its minimum flow mechanical stop (where applicable).

3.4.4.13.4 Alarms

A high temperature alarm on each heater pass should be considered in coking service or when each pass has its own flow controller.

In the case of a combined outlet temperature, the thermowell should be installed where all the pass flows are well-mixed to give a representative temperature of the combined outlet stream.

3.4.4.13.5 Protective Functions

No protective functions are recommended.

3.4.4.14 High Tube Skin Temperature

3.4.4.14.1 Process Hazard

High tube skin temperatures may result in reduction of tube life or tube failure.

3.4.4.14.2 Consideration

Additional design consideration should be given to the following items.

a) High tube skin temperatures may be caused by:

- coking or corrosion deposits within the tubes,
- low flow to one or more passes,
- high firing rate relative to the flow rate through the tubes,
- poor heat distribution,
- flame impingement on one or more tubes.

b) Infrared (IR) monitoring may be used to supplement on-line tube skin instruments, but IR measurement readings can also be influenced by several variables such as oxide scale on the tube's outside diameter, flue gas atmosphere, angle of incidence from IR monitor to the measured tube, specific IR monitor, and tube emissivity.

c) Adequate view of all radiant and shock tubes should be available.

3.4.4.14.3 Alarms

Where applicable, tube skin thermocouples should have a high temperature alarm.

3.4.4.14.4 Protective Functions

No protective functions are recommended.

3.4.4.15 Air Preheater Malfunction

3.4.4.15.1 Process Hazard

For many designs high and low temperature can lead to mechanical integrity issues (e.g. dew point corrosion, consequent leakage and fouling). For regenerative pre-heaters (rotating wheel) designs, rapid overheating and localized failure can occur.

3.4.4.15.2 Considerations

Additional design consideration should be given to the following items.

- a) Consider attaching thermocouples to the coldest components of recuperative air preheaters. When sulfur is present in the fuel gas, aqueous sulfuric acid will condense on components that are at or below the dew point of the flue gas. This can lead to corrosion and fouling of the cold end of the exchanger.
- b) When thermocouples are attached to the coldest components of recuperative air preheaters, consider providing a means of bypassing some combustion air around the air preheater. The cold element temperature can then be controlled by altering the flow through the combustion air bypass.

3.4.4.15.3 Alarms

Multiple alarms may be used to assist the operators.

- a) Where applicable, provide an alarm on the loss of rotation of the regenerative pre-heater (rotating wheel).
- b) A high flue gas temperature and low flue gas temperature alarm should be provided between the air preheater and ID fan.
- c) Where applicable, thermocouples attached to the coldest components of recuperative air preheaters should have a low temperature alarm.

3.4.4.15.4 Protective Functions

For regenerative pre-heater (rotating wheel) designs an automated corrective action is recommended to avoid mechanical damage. The corrective action depends on the equipment. A bypass is typical along with a trip of the ID fan and opening of the stack damper.

3.4.5 Manual Trip (Emergency Shutdown)

A manual trip shall be provided to isolate all fuel sources.

No single action for the fans, dampers, dropout doors, and snuffing steam can be prescribed for different hazard scenarios. Thus, hazards should be evaluated prior to taking corrective action to safe state. To maximize the available options, consider the following.

- Providing an additional manual trip pushbutton for fuel gas and waste gas only (leave pilots operating, where applicable).

- For natural draft heaters, isolate all fuel sources and hold stack damper in the last position.
- For heaters with FD fans, isolate all fuel sources and transition to minimum combustion air flow:
 - Option 1:** shutdown the FD fan and open the natural draft dropout doors. For forced draft heaters, hold the stack damper in the last position. For balanced draft heaters, shutdown the ID fan and open the stack damper to a predetermined position.
 - Option 2:** reduce the combustion air flow to a minimum flow rate. For forced draft heaters, hold the stack damper in the last position. For balanced draft heaters, open the combustion air bypass around the air preheater, shutdown the ID fan and open the stack damper to a predetermined position.
- To facilitate response to a tube rupture, isolate all fuel sources (process and fuels), shutdown the FD fan, keep the natural draft dropout doors closed and initiate snuffing steam. These actions are not prescriptive however the goal is to minimize the hazard and may best be handled by keeping the tube rupture fire burning in some scenarios. For forced draft heaters, hold the stack damper in the last position. For balanced draft heaters, shutdown the ID fan and open the stack damper to a predetermined position.

Additional considerations include:

- Most manual trips are hardwired to interrupt power to the field devices. Some safety certified programmable logic solvers have special certification allowing manual trip pushbuttons to be wired directly to the logic solver input, and the logic solver interrupts power to the field devices. Consult the vendor safety manual.
- When integrated into a programmable logic solver, the protective system logic shall not have logic designed to prevent the manual shutdown from occurring, e.g. regardless of logic state, alarm states, process measurements, etc.
- The manual trip shall use latching logic. A pull to trip switch is a design consideration to minimize accidental initiation. A pull or push to trip policy should be uniformly applied across the facility, and the required action should be clearly labeled and visible to the operator.
- The manual trips shall be clearly designated and identified.
- A local manual trip is recommended. The local manual trip should be located within visible distance from the heater to allow safe access and egress during an emergency situation, for example if a flameout or other hazardous event occurs during burner light off. Typical locations are on field panels.
- Where existing field panels do not allow for safe access and egress during an emergency situation, or where the radiant heat from a heater fire may prohibit access, it is recommended to have a secondary manual trip outside of a 50 ft (16 m) zone. A design consideration is to install a manual quarter turn tight shutoff valve outside battery limits [> 50 ft (> 16 m)] clearly marked for emergency isolation.

A minimum of two emergency shutdown locations is recommended. Therefore, if a manual trip location outside of a 50 ft (16 m) zone is not available, then a remote manual trip from a continuously manned location (always recommended) such as a central control room may be required (e.g. DCS remote trip).

3.4.6 Safety Shutoff and Bypass Valves

3.4.6.1 Safety Shutoff Valves

The following items apply to shutoff valves used in safety instrumented functions.

- Safety shutoff valves are used to isolate fuel sources (fuel gas, pilot gas or waste heat gas) to a heater after initiation by any of the protective functions, including manual shutdown.
- Safety shutoff valves shall be fail-safe (spring return fail closed) and should remain closed until safe conditions are present (i.e. manual reset).
- Safety shutoff valves shall not have hand wheels.
- Solenoid operated valves shall not allow forcing or reset to the normal position when de-energized.
- Solenoid operated valves shall be installed de-energized to trip and require manual reset.
- Re-opening after a trip shall require manual intervention locally at the heater after all permissives are satisfied. This manual intervention may take the form of a manual reset pushbutton or switch, or manual reset solenoid valves.
- Safety shutoff valves should provide tight shutoff, per ANSI/FCI 70-2 Class V or VI or bubble tight per API 598. Tight shutoff is not a performance criterion to achieve safe state. Instead, tight shutoff is specified to ensure that fuel gas does not accumulate in the heater during an extended shutdown. The criteria for resolving unacceptable seat leakage rates (e.g. with valve proving systems) and valve maintenance intervals should be determined by the owner/operator.
- Safety shutoff valves should not be used in lieu of manual isolation valve(s) and/or blind for extended shutdown periods.
- Safety shutoff valves shall either be fire safe per API 607 or API 6FA or be located in a fire safe area.
- Unless otherwise noted in the Safety Requirement Specifications, safety shutoff valves shall have a maximum travel time as noted below:
 - Up to 4 in. < 3 seconds,
 - 6 in. to 8 in. < 4 seconds,
 - 8 in. to 12 in. < 5 seconds.

Since safe state must be achieved within the available process safety time of 5 seconds to 10 seconds (see 3.4.4.1.2), the Safety Requirement Specifications may prescribe time to safe state not to exceed 5 seconds. This may require larger actuator connections ($\geq 1/2$ in. NPT) and quick exhaust valves ($\geq 1/2$ in. orifice) to expedite valve closure time.

It is recommended that two valves in series be used to isolate fuel gas. This can take the form of double block safety valves (on/off) or a safety shutoff valve used in conjunction with a tight shutoff control valve.

- When used as a safety shutoff valve, the control valve cannot have a minimum stop, nor use a start up or minimum firing pressure regulator bypass valve.
- If the control valve is used as a safety shutoff valve, the startup bypass valve shall be car sealed (or locked) closed and cannot be used for minimum fire operation. Due to the difficulty of full stroke testing a control valve

online, a control valve should be used as a safety shutoff valve only when the proof test interval is greater than or equal to the turnaround interval to facilitate offline testing.

- A double block valve (on/off) arrangement, for one-out-of-two (1oo2) voting, allows for higher performance (SIL) ratings and requires less proof testing than a single block valve.

In many fired heater applications, the use of a bleed valve between two automated block valves has been discontinued due to environmental and safety implications of releasing fuel gas to the atmosphere. In the absence of a bleed valve, there may be increased concern for seat leakage of fuel gas into the heater. Since the automated block valves should maintain tight shutoff requirements, the purge cycle and sniffing a cold firebox with a portable combustibles analyzer prior to light off minimizes the process hazard. If the owner/operator elects to implement a valve proving system to verify seat integrity, it is recommended that the automated block valves be proven at the scheduled outage instead of waiting until the startup sequence. This facilitates valve testing and repair in a more practical and timely manner. The basis for seat leakage flow rates at the testing pressure, the corresponding pressure setpoints, and the delay timers that define pass/fail criteria should be documented during the project design phase.

Safety shutoff valves should be provided with proof of closure indication for shutdown verification and startup sequencing.

- A proof of closure valve diagnostic alarm is recommended if a safety shutoff valve fails to close within the prescribed time requirements (e.g. 5 seconds to 10 seconds or twice the valve stroke time).
- If both safety shutoff valves fail to close the operator should assume loss of flame, clear the area of personnel, and isolate fuel gas outside battery limits prior to approaching the heater.

The shutoff valve actuators should be sized with a safety factor of 25 % to 40 % more power in addition to typical considerations of the minimum instrument air pressure, operating conditions, and breakaway force or torque required to move the valve.

3.4.6.2 Bypass Valves (around Safety Shutoff Valves)

The following items apply to shutoff valve bypasses used in safety instrumented functions.

- Manual double blocks, or a double block and blind arrangement, may be installed in parallel with the safety shutoff valves to facilitate full stroke online testing of safety valves.
- Bypass valves shall not be used to bypass unsafe process conditions.
- Bypass valves shall either be fire safe per API 607 or API 6FA or be located in a fire safe area.
- Bypass valves shall be provided with a proof-of-closure status alarm in a manned location or car sealed closed (or locked) when not in use.
- A formal policy, permitting procedure, and signed authorization shall be required prior to opening the bypass valves. For facilities that have reservations with administrative control of bypass valves, an automated partial stroke test of the safety shutoff valves may be considered to meet proof test requirements without safety shutoff bypass valves.
- Quarter turn or quick turn manual valves that can be quickly closed in an emergency are recommended.
- The bypass valves shall not be used as a start up bypass.

3.4.7 Pre-Ignition Purge Cycle

Prior to each fired heater startup, provision shall be made for the removal of combustible gases which may have entered the heater during the shutdown period. A timed pre-ignition purge cycle shall be repeated after every shutdown of all fuel sources (main fuel gas, waste gas, and pilot gas).

Prior to initiating a purge, precautions should be taken to avoid completing the air-fuel-ignition triangle. By removing any component of the triangle, the likelihood of a deflagration during the purge cycle is significantly reduced.

Should combustibles accumulate in the firebox to an unacceptable hazard level (see 3.4.4.1.2) prior to a trip, precautions should be taken to mitigate the inrush of air when components within the firebox are hot enough to serve as the source of ignition.

3.4.7.1 Heated Analyzer Sensors as a Potential Ignition Source

When the purging of a fuel rich environment may create a hazardous gas mixture in the firebox, provisions should be made to prevent a heated oxygen, combustibles, or methane sensor (without flame arrestors) from becoming an ignition source. Options include:

- a) Turn off the sensor power prior to initiating the purge cycle to allow the sensor to cool below the fuel gas ignition temperature (e.g. 30 minutes to 60 minutes). Upon restoring power, an oxygen sensor may require stabilization time (e.g. 15 minutes to 30 minutes) to achieve published accuracy. A cold combustibles or methane sensor at ambient conditions may have an extended warm up period (e.g. 4 hours to 6 hours) for the sensors to stabilize to published accuracy.
- b) Reverse flow (blow back) instrument air or nitrogen through the sample probe during the purge cycle, for close-coupled extractive systems without flame arrestors. Upon purge complete, standard sample flow is resumed with no sensor stabilization time due to interruption of power.
- c) Install flame arrestor(s); however, they add lag time (estimated 5 seconds to 10 seconds extractive and 1 minute for in-situ probe systems) which is a consideration for process control or process safety applications where response time is critical.

3.4.7.2 Purging a Natural Draft Heater

Purge options are as follows.

- a) Air purge.
 - The default purge timer is typically 15 minutes to target five heater volume changes. However, since draft varies with firebox temperature, the number of volume changes may be difficult to resolve. Therefore, it is recommended to sniff the firebox prior to ignition as stated below.
 - A bridgwall temperature indication may be used as the basis for shortening the purge time requirements as a hot firebox will draft more air.
 - An air draft may be induced by injecting steam into the base of the stack which may improve pilot reliability by keeping igniters and flame rods dry (where applicable).
- b) Steam purge.
 - Inject low pressure steam into the radiant section for at least 15 minutes for three heater volume changes. Since steam is inert in this context, fewer volume changes are required than with an air purge.

- It is difficult to calculate purge volumes with a steam medium. Therefore the purge timer should not start until steam is visually confirmed exiting the stack. The steam valve shall be sufficiently opened (e.g. > 50%) to establish sufficient purge velocity.
- Steam purging a radiant section can be a problem in cold weather locations due to the condensing of the steam in the firebox. A slow heat up rate is recommended to ensure this water is re-evaporated and the refractory dried.

Especially for a cold firebox, use a portable analyzer to check the firebox for combustibles through openings in the burners and/or observation doors at several locations.

3.4.7.3 Purging a Forced Draft Heater

Purge airflow shall reach no less than 70 % of the airflow required at maximum continuous capacity of the unit. Confirm the purge interlock by satisfying either:

- a) combustion air pressure (see 3.2.2.2) and all dampers in the flow path fully open,
- b) combustion air flow transmitter.

Purge for a period of not less than 5 minutes or five heater volume changes, whichever is greater, prior to being placed into service.

Consider the use of a portable analyzer to check the firebox for combustibles through openings in the burners and/or observation doors at several locations.

3.4.7.4 Purging the Air Preheater

If the firebox is fuel rich, a consideration is to purge the flue gas side of the preheat system by starting the ID fan, closing the stack damper, and purging the firebox in balanced draft mode. However, the ID fan does not typically have sufficient turndown to light the burners in balanced draft mode.

3.4.7.5 Restart with Continuous Pilots (where applicable)

For each trip scenario, the owner/operator should evaluate the potential for creating a fuel rich environment within the firebox. The probability of combustibles accumulating to hazardous levels is reduced when trip setpoints and delay trip timers for protective functions (see 3.4.4.1.5) are selected to precede flameout.

For trip scenarios that have a low probability of creating a hazardous gas mixture in the firebox, a trip to continuous pilot(s) may permit the restart of main burner(s) without a full pre-ignition purge cycle. As a safety enhancement, consider holding the combustion air and flue gas registers/dampers in last position and delay the restart to permit a minimum of one volume change to sweep the firebox (e.g. 1 minute to 2 minutes for a forced draft heater or 5 minutes for a natural draft heater).

For a trip scenario with a higher probability of creating a hazardous gas mixture in the firebox, or where the probability is difficult to assess, it is recommended to turn off the pilots and perform a full pre-ignition purge cycle.

3.4.8 Alarm Summary Table

Table 1 outlines the recommended alarms.

Table 1—Alarm Summary Table

Low fuel gas pressure downstream of the fuel gas control valve.
High fuel gas pressure downstream of the fuel gas control valve.
Low combustion air flow/pressure (if applicable)
Low air duct pressure (if applicable)
Loss of forced draft fan (if applicable)
Low forced draft fan speed (if applicable)
High fan vibration (if applicable)
High motor amps (if applicable)
High and low differential pressure across the forced draft fan (if applicable)
Dropout door(s) (natural draft) failure to open/close (if applicable)
Low draft (high firebox pressure)
High draft (low firebox pressure)
Loss of induced draft fan failure (if applicable)
Low induced draft fan speed (if applicable)
High and low differential pressure across the induced draft fan (if measured) (if applicable)
High induced draft fan inlet temperature (if applicable)
Stack damper failure to open (if applicable)
Stack damper position deviation alarm (if applicable)
High and Low bridgeway temperature
Low firebox floor temperature (if applicable)
High stack temperature located upstream of the stack damper
Low stack temperature when corrosion is a concern
High liquid level in an upstream fuel gas drum
Low air/fuel ratio
Low oxygen
High combustibles (if applicable)
High CO (if applicable)
Loss of flame at one or more burners detected via flame scanners (if applicable)
Flooding alarm
High methane (if applicable)
Proof of closure valve diagnostic alarm
Low pilot gas pressure (if applicable)
High pilot gas pressure (if applicable)
Loss of pilot flame (if applicable)

Table 1—Alarm Summary Table (Continued)

Low pass (s) or total flow
High process outlet temperature
High tube-skin temperature
High NO _x (if applicable)
High SO _x (if applicable)
Manual shutdown-fuel gas
Manual shutdown-pilot gas (if applicable)
Low velocity steam or condensate flow (if applicable)
Pre-heater failure (if applicable)
High/Low flue gas temperature between the air preheater and ID fan
Deviation alarms (redundant transmitters)
SIS system diagnostic alarms

3.4.9 Safe State Table

Table 2 summarizes considerations for corrective action to safe state including control overrides, operator response to alarms, and protective functions. For clarification, reference the respective sections.

Table 2—Safe State Table

Process Deviation	Process Hazard	Protective Function Type	Control Overrides and Protective Functions	Safe State	Operator Safe Response
3.4.4.1 Accumulation of Combustibles within the Firebox (Loss of Flame, Substoichiometric Combustion, or Tube Leaks)	Accumulation of combustibles within the firebox, subsequent explosion potential	CONTROL	<ul style="list-style-type: none"> — Low/high fuel gas burner pressure override to fuel gas controller — Reduce firing rate to established turndown condition during transition from balanced/forced draft to natural draft — Low draft (high firebox pressure) override to the stack damper or fuel gas controller — Low oxygen or high combustibles override to the fuel gas controller 	N/A	Substoichiometric Combustion—See 3.4.4.1.5 for Operator Response to a Fuel Rich Environment. Tube Leak—Operators to follow specific site instructions for this case
		SAFETY	Close main fuel gas shutoff valves	Main fuel gas shutoff valves closed	Operator to verify safety shutoff valves and bypass valves (where applicable) are closed. See Notes 1, 2, 3.
3.4.4.2 Low burner fuel gas pressure	Poor flame quality and potential unstable flame	CONTROL	Low fuel gas burner pressure override to the fuel gas controller	N/A	Operator to evaluate low pressure alarm and take corrective action to keep the heater within operational limits.

Table 2—Safe State Table (Continued)

Process Deviation	Process Hazard	Protective Function Type	Control Overrides and Protective Functions	Safe State	Operator Safe Response
3.4.4.2 Low-low burner fuel gas pressure	Accumulation combustibles within the firebox, subsequent explosion potential	SAFETY	Close main fuel gas shutoff valves	Main fuel gas shutoff valves closed	Operator to verify safety shutoff valves and bypass valves (where applicable) are closed. See Notes 1, 2, 3.
3.4.4.3 High burner fuel gas burner pressure	Poor flame quality and potential unstable flame	CONTROL	Option 1 – High fuel gas burner pressure override to the fuel gas controller	N/A	Operator to evaluate high pressure alarm and respond by lighting more burners or reduce firing rate.
			Option 2 – Reduce firing rate	N/A	Operator to verify reduced firing rate.
3.4.4.3 High-high main fuel gas burner pressure	Accumulation of combustibles within the firebox, subsequent explosion potential	SAFETY	Close main fuel gas shutoff valves	Main fuel gas shutoff valves closed	Operator to verify safety shutoff valves and bypass valves (where applicable) are closed. See Notes 1, 2, 3.
3.4.4.4 Low combustion air flow	Poor flame quality and potential unstable flame	CONTROL	— Air/fuel ratio cross-limiting controls — Low oxygen override to the fuel gas controller	N/A	Operator to evaluate low combustion air flow alarm and take corrective action to keep the heater within operational limits.
3.4.4.4 Low-low combustion air flow, or loss of FD fan	Accumulation of combustibles within the firebox, subsequent explosion potential	SAFETY	Action 1 - Open dropout door(s) and stack damper (where applicable). Firing rate should be automatically reduced (as required) to a predetermined natural draft mode setting.	Natural draft operating mode (where applicable)	Operator to verify dropout door(s) are open
			Action 2 - Close main fuel gas shutoff valves	Main fuel gas shutoff valves closed	Operator to verify safety shutoff valves and bypass valves (where applicable) are closed. See Notes 1, 2, 3.
3.4.4.5 Failure of dropout doors to open	Rapid accumulation of combustibles within the firebox due to insufficient combustion air, subsequent explosion potential with reintroduction of air if the firebox is above ignition temperature	CONTROL	N/A	N/A	N/A
		SAFETY	If the dropout doors fail to open within the allowable time frame (typically within 5 seconds to 10 seconds) the fuel gas shutoff valves shall be closed.	Main fuel gas and pilot gas shutoff valves closed	Operator to verify safety shutoff valves and bypass valves (where applicable) are closed. See Notes 1, 2, 3.

Table 2—Safe State Table (Continued)

Process Deviation	Process Hazard	Protective Function Type	Control Overrides and Protective Functions	Safe State	Operator Safe Response
3.4.4.6 Low draft (high firebox pressure)	Poor flame quality and potential unstable flame	CONTROL	FD and ND Heaters - Consider implementing overrides in the following order: a) open stack damper b) decrease fuel gas controller Induced/Balanced Draft - Consider implementing overrides in the following order: a) open inlet draft damper (single speed fan) or increase fan speed (VFD) b) open stack damper c) decrease fuel gas controller	N/A	Operator to evaluate low draft (high firebox pressure) alarm and take corrective action to keep the heater within operational limits.
3.4.4.6 Low-low draft (high-high firebox pressure) or loss of induced draft fan	Explosion potential for burners subject to flameout, e.g. low-NO _x burner applications	SAFETY	Natural Draft - Open stack damper (optional)	Normal heater operation with loss of draft control.	Operator to investigate loss of draft control and take corrective action to keep the heater within operational limits.
			Balanced or Induced Draft - If either the stack damper fails to open or the firebox pressure is not relieved within time constraints the fuel gas shutoff valves shall be closed Forced Draft - For forced draft heaters, low draft (high firebox pressure) trip is optional when the forced draft fan is operating and combustion air flow is measured directly with a flow transmitter Natural Draft - The fuel gas shutoff valves should be closed only where a low draft (high firebox pressure) condition is likely to yield loss of flame.	Main fuel gas shutoff valves closed	Operator to verify safety shutoff valves and bypass valves (where applicable) are closed. See Notes 1, 2, 3.
3.4.4.7 Failure of stack damper to open	Rapid accumulation of combustibles within the firebox, subsequent explosion potential	SAFETY	Close fuel gas shutoff valves	Main fuel gas and pilot gas shutoff valves closed	Operator to verify safety shutoff valves and bypass valves (where applicable) are closed. See Notes 1, 2, 3.

Table 2—Safe State Table (Continued)

Process Deviation	Process Hazard	Protective Function Type	Control Overrides and Protective Functions	Safe State	Operator Safe Response
3.4.4.8 High firebox temperature	Decreased reliability	CONTROL	N/A	N/A	Operator to evaluate high bridgewall temperature alarm and take corrective action to keep the heater within operational limits.
3.4.4.8 Low radiant floor or low firebox temperatures (where applicable)	Poor flame quality and potential unstable flame	CONTROL	N/A	N/A	Operator to evaluate low radiant floor temperature or low firebox temperature alarms and take corrective action to keep the heater within operational limits.
3.4.4.8 Low stack flue gas temperature	Acid dew point condensation; Erratic gas sampling readings	CONTROL	N/A	N/A	Operator to verify temperature controls and number of burners on.
3.4.4.8 High stack flue gas temperature	Over firing; Leaking heater tubes; Combustibles after burning	CONTROL	N/A	N/A	Operator to verify temperature controls, visually inspect the stack and reduce firing.
3.4.4.9 Low oxygen	Unstable flame	CONTROL	— Low oxygen override to the fuel gas controller — Oxygen trim control to the air or air/fuel ratio controller (where applicable)	N/A	Operator to evaluate low oxygen alarm and take corrective action to keep the heater within operational limits.
3.4.4.10 Low pilot gas pressure	Unstable pilot flame	CONTROL	N/A	N/A	Operator to evaluate low pilot pressure gas alarm and take corrective action.
3.4.4.10 Low-low pilot gas pressure	Accumulation of combustibles within the firebox during pilot only mode, subsequent explosion potential	SAFETY	Close pilot gas shutoff valves	Pilot gas shutoff valves closed	Operator to verify pilot safety shutoff valves are closed. See Notes 1, 2, 3.
3.4.4.11 High pilot gas pressure	Unstable pilot flame	CONTROL	N/A	N/A	Operator to evaluate high pilot pressure gas alarm and take corrective action.

Table 2—Safe State Table (Continued)

Process Deviation	Process Hazard	Protective Function Type	Control Overrides and Protective Functions	Safe State	Operator Safe Response
3.4.4.11 High-high pilot gas pressure	Accumulation of combustibles within the firebox during pilot only mode, subsequent explosion potential	SAFETY	Close pilot gas shutoff valves	Pilot gas shutoff valves closed	Operator to verify pilot safety shutoff valves are closed. See Notes 1, 2, 3.
3.4.4.12 Low charge or feed flow	- Heater tubes overheating;	CONTROL	— Pass flow control valve minimum flow stop (mechanical, soft stop in valve positioner, or controller setpoint or output limits)	N/A	Operator to evaluate low flow alarm and take corrective action to keep the heater within operational limits. On coking services, operator to verify “velocity” steam has been automatically injected to purge the coils.
			— For some services, inject steam into the coil		
3.4.4.12 Low-low charge or feed flow	- Heater tubes overheating; - Tubes coking; - Tube(s) failure	SAFETY	Close main fuel gas shutdown valves upon loss of charge flow. Exception – Some heater manufacturers design the process tubes to sustain minimum fire heat release at zero process flow conditions. In this case, a Low Fire Shutdown (minimum fire operation) may be specified in lieu of a Main Gas Shutdown	Fuel gas shutoff valves closed	Operator to verify safety shutoff valves are closed. See Notes 1, 2, 3.
			— Optional - Reduce firing rate upon low charge flow		
3.4.4.13 High process outlet temperature	Multiple process and mechanical integrity issues	CONTROL	Optional: Single high outlet pass or multiple high outlet pass temperatures, DCS reduces firing rate	Reduced firing or minimum fire operation	Operator to evaluate high temperature alarm and reduce firing rate.
3.4.4.13 High-high process outlet temperature	Multiple process and mechanical integrity issues	SAFETY	No action recommended.	N/A	N/A
3.4.4.14 High tube-skin temperature	Tube damage Tube coking	CONTROL	N/A	N/A	
3.4.4.15 Air Preheater	Mechanical damage to the preheater upon malfunction	CONTROL	Bypass air preheater (FD mode or natural draft) Shutdown ID fan and open stack damper	Air preheater bypassed	Operator to verify stack damper open and induced draft fan shutdown

NOTE 1 Proof of closure indication is typically integrated into the logic solver with indications to the HMI and/or DCS.

NOTE 2 A proof of closure valve diagnostic alarm is recommended if a safety shutoff valve fails to close within the prescribed time requirements (e.g. within 5 seconds to 10 seconds).

NOTE 3 If both safety shutoff valves fail to close the operator should assume loss of flame, clear the area of personnel, and isolate fuel gas outside battery limits prior to approaching the heater.

3.4.10 Cause and Effects Table

Table 3 should be used in conjunction with 3.4.4 Protective Functions and 3.4.9, Table 2, Safe State Table.

Table 3—Cause and Effects Table¹

Section 3.4.4 Protective Functions	Natural Draft		Trip to Mode	Forced/Balanced/Induced Draft					
	Fuel Gas ²	Pilot Gas ⁹		Fuel Gas	Pilot Gas ⁹	Stack Damper	Forced Draft Fan	Induced Draft Fan	Natural Draft Doors
3.4.4.1 Accumulation of Combustibles within the Firebox, Loss of Flame	Close			Close					
3.4.4.2 Low Fuel Gas Burner Pressure	Close			Close					
3.4.4.3 High Fuel Gas Burner Pressure	Close			Close					
3.4.4.4 Low Combustion Air Flow or Loss of FD Fan			ND			Open	Off ³	Off ³	Open
3.4.4.5 Failure of Dropout Doors to Open, upon trip to ND mode				Close					
3.4.4.6 Low Draft (High Firebox Pressure) or Loss of ID Fan	Close ⁴		FD			Open		Off ³	
3.4.4.7 Failure of Stack Damper to Open				Close					
3.4.4.10 Low Pilot Gas Pressure		Close			Close				
3.4.4.11 High Pilot Gas Pressure		Close			Close				
3.4.4.12 Low Charge or Feed Flow	Close ⁶			Close ⁶					
3.4.5 Fuel Gas Manual Shutdown	Close			Close					
3.4.5 Total Manual Shutdown (Emergency Shutdown)	Close	Close ⁷		Close	Close ⁷	Open ⁸	Off ⁸	Off ⁸	Open ⁸

1 The diversity in the design of fired heaters requires that each heater be independently evaluated to ensure that each hazard scenario is effectively mitigated. Since each heater may have unique features or operational modes, it is critically important that those responsible for assessing the availability and reliability of a protective function understand all of the possible equipment failure modes and the potential impact to the operating unit and personnel.

2 In the event of a fuel gas trip, natural draft (ND) heaters should hold the stack damper in the last position. The basis is to ensure that an inrush of air into a fuel rich environment when the firebox is above ignition temperature does not create a hazardous situation. See 3.4.4.1.5 for Operator Response to a Fuel Rich Environment.

3 Option to keep the fans running for transition to normal operating mode upon trip. Upon loss of forced draft (FD) fan, leaving the induced draft (ID) fan running may overheat the preheater. Upon loss of ID fan, the FD fan may cool the preheater below the flue gas dewpoint.

4 For natural draft heaters, the fuel gas shutoff valves should be closed where a low draft (high firebox pressure) condition is likely to yield loss of flame due insufficient draft of combustion air or backflow of flue gas into the plenum.

5 For forced draft heaters, a low draft (high firebox pressure) trip is optional when the forced draft fan is operating and combustion air flow is measured directly with a flow transmitter

6 Tripping fuel gas to the heater is the recommended action. However, minimum fire may be considered after careful analysis to insure that the mechanical integrity of the process tubes cannot be compromised at minimum fire flow rates.

7 If an independent Pilot Gas Manual Shutdown is employed for continuous duty pilots, the push button should be clearly labeled so it is not confused with the Main Fuel Gas Manual Shutdown. Typically, a single pushbutton isolates all fuel sources.

8 Corrective action is dependent upon hazard scenario. See 3.4.5 for additional information.

9 For a restart with continuous pilots (where applicable) see 3.4.7.5.

3.4.11 Startup Sequence Table

This startup sequences in Table 4 and Table 5 are for process heaters with pilots and lists sequential steps to be considered for a safe heater startup. Pilot burners shall be provided on each burner unless stated otherwise by the owner. The startup sequence for process heaters without pilots is similar. For natural draft and forced draft heaters without pilots, Steps 11 thru 14 are not required and main burners are lit at Step 18. Prior to the ignition sequence, provision shall be made for purging combustible gases that may have entered the heater during the shutdown period (see 3.4.7).

When purging a firebox at temperatures below the ignition temperature of the fuel gas, provisions should be made to prevent a heated oxygen, combustibles, or methane sensor from becoming an ignition source. Mitigation options include a purge interlock to disconnect sensor power, reverse flow of close-coupled extractive systems, or the use of flame arrestors.

The startup sequence may include the following manual or automatic steps.

3.4.11.1 Natural Draft Heaters

Table 4—Startup Sequence, Natural Draft Heaters

Step	Action
1	Confirm that the main fuel, waste gas, and pilot gas safety shutoff valves, and any bypass valves, are closed. NOTE Proof of closure for safety shutoff valves is a purge permissive.
2	Where required to facilitate individual light off of multiple burners, confirm that individual fuel gas and pilot gas cock valves are closed.
3	Confirm that no flame is present at the burner. NOTE Where applicable, confirm that flame scanners indicate off. The basis is to ensure the scanner is not faulty prior to startup. No flame present is a purge permissive.
4	Confirm that pilot gas and fuel gas header pressure are above minimum requirements. The basis is to prevent an immediate demand to trip upon low burner pressure at startup. NOTE Minimum fuel gas header pressure may be a permissive to light the pilots and main fuel gas.
5	Confirm that burner air registers are open (e.g. visually) and stack dampers are fully open (e.g. via position indication). NOTE Proof of stack damper open is a purge permissive.
6	Reset manual shutdown pushbuttons/switches and alarms at local panel/control room.
7	Establish balanced process flow through heater passes per operating procedures. NOTE Minimum pass flow(s) may not be a permissive to light the pilots (e.g. to facilitate refractory curing), but is a permissive to introduce main fuel gas.
8	Initiate the purge cycle (see 3.4.7.2). The default purge timer is typically 15 minutes; however, a firebox temperature indication may assist with shortening the purge time requirements. The basis is that a hot firebox will draft more air.
9	When the purge cycle is complete and purge steam has been isolated (where applicable), use a portable LEL detector to sniff a cold firebox at predetermined locations to confirm that combustibles are not present. The basis is that it may be difficult to induce a draft in a cold firebox.
10	Confirm that air registers and fuel gas control valves are in light-off positions. Where applicable, stack damper should remain fully open.
11	When the purge cycle is complete (sequence permissive), manually command the pilot gas shutoff valves to open. This can be in the form of a manual reset or pushbutton. A pilot trial-for-ignition timer may or may not be used for this step. NOTE 1 Some applications use a manual reset solenoid valve. For these applications, solenoid construction with a lever that cannot be defeated is recommended. NOTE 2 For applications that use double block and bleed on pilot gas, it is recommended that the bleed valve is confirmed closed before the double block valves open. The basis is to mitigate blowing fuel gas to atmosphere. Should the bleed valve open or fail to prove closed during the startup sequence, a manual isolation valve beneath the bleed valve may be considered to continue the light off sequence. NOTE 3 A startup override of the low pilot gas pressure trip is typically required to permit opening of the pilot gas block valves. Otherwise, the low pressure condition at startup below the trip setpoint would not allow the block valves to be sequenced open. Once the pilot pressure is confirmed above the low pressure trip setpoint for a fixed time interval, the logic solver will typically activate the low pressure protective function.

Table 4—Startup Sequence, Natural Draft Heaters (Continued)

Step	Action
12	<p>Confirm that pilot gas pressure (i.e. downstream of the regulator and safety shutoff valves) is within the operating or flame stability limits of the pilot.</p> <p>NOTE If pilot gas cock valves are closed, the pilot gas regulator may creep to header pressure. In this case, the pilot gas header pressure should be reduced (e.g. vented to flare) within operating limits prior to light off.</p>
13	<p>Light off each pilot independently.</p> <p>NOTE 1 For multiple pilots, it is typically recommended to light one pilot at a time. If a pilot fails to light (typically within 10 seconds to 15 seconds), that pilot should be isolated prior to troubleshooting. Allow that pilot area to purge itself prior to a relight attempt. The basis is to ensure the unburned fuel gas concentration in the firebox is not permitted to exceed 25 % of the LEL during light off; otherwise a re-purge is required.</p> <p>NOTE 2 If pilot gas pressure does not remain within the operating or flame stability limits during light off, a high/low pilot gas pressure protective function should trip the safety shutoff valves in which case the purge cycle should be repeated.</p>
14	<p>Complete light off for pilots, and confirm pilots are lighted via visual confirmation or electronic flame monitoring.</p>
15	<p>Manually command the main fuel gas shutoff valves to open. This can be in the form of a manual reset or pushbutton. A main burner trial-for-ignition timer may or may not be used for this step.</p> <p>NOTE 1 Some applications use a manual reset solenoid valve. For these applications, solenoid construction with a lever that cannot be defeated is recommended.</p> <p>NOTE 2 A startup override of the low fuel gas burner pressure trip is typically required to permit opening of the main fuel gas block valves. Otherwise, the low pressure condition at startup below the trip setpoint would not allow the block valves to be sequenced open. Once the burner pressure is confirmed above the low pressure trip setpoint for a fixed time interval, the logic solver will typically activate the low pressure protective function.</p>
16	<p>For applications that use double block and bleed on main fuel gas, it is recommended that the bleed valve is confirmed closed before the double block valves open. The basis is to mitigate blowing fuel gas to atmosphere.</p> <p>NOTE Should the bleed valve open or fail to prove closed during the startup sequence, a manual isolation valve beneath the bleed valve may be considered to continue the light off sequence.</p>
17	<p>Confirm that the fuel gas control valve is in the light off position and that the burner pressure is controlled at light off pressure. Light the burner(s) per standard operating procedures (SOP).</p> <p>NOTE 1 Fuel gas pressure may rise to header pressure when main burner cock valves are closed. In this case, the pressure should be reduced (e.g. vented to flare) within the operating limits prior to light off.</p> <p>NOTE 2 Where the control valve has insufficient turndown to light off the first few burners, alternate considerations (see Section 3.3.1) to maintain the desired light off pressure may include a minimum flow orifice or a minimum fire regulator. Each startup device is typically sized to light the first few burners until the control valve is within control range. Each must be installed in parallel with the fuel gas control valve. Neither is permitted to bypass the safety shutoff valves.</p>
18	<p>Light the main burners individually.</p> <p>NOTE 1 For multiple burners, it is typically recommended to light one burner at a time. If a burner fails to light (typically within 10 seconds to 15 seconds), that burner should be isolated prior to troubleshooting. Allow that burner area to purge itself prior to a relight attempt. The basis is to ensure the unburned fuel gas concentration in the firebox is not permitted to exceed 25 % of the LEL during light off; otherwise a re-purge is required.</p> <p>NOTE 2 If burner gas pressure does not remain within the operating or flame stability limits during light off, a high/low fuel gas pressure protective function should trip the safety shutoff valves in which case the purge cycle should be repeated (except where continuous pilots provide hot restart capability).</p>
19	<p>Light as many burners as required to achieve the desired startup heating requirements ensuring that burner pressure stays within the operating or flame stability limits.</p>
20	<p>Set the fuel gas controller to automatic mode (release to modulate) when appropriate.</p>

3.4.11.2 Forced Draft and Balanced Draft Heaters

Table 5—Startup Sequence, Forced Draft and Balanced Draft Heaters

Step	Action
1	<p>Confirm that the main fuel and pilot gas safety shutoff valves, and any bypass valves, are closed.</p> <p>NOTE Proof of closure for safety shutoff valves is a purge permissive.</p>
2	<p>Where required to facilitate individual light off of multiple burners, confirm that individual fuel gas and pilot gas cock valves are closed.</p>
3	<p>Confirm that no flame is present at the burner.</p> <p>NOTE Where applicable, confirm that flame scanners indicate off. The basis is to ensure the scanner is not faulty prior to startup. No flame present is a purge permissive.</p>
4	<p>Confirm that pilot gas and fuel gas header pressure are above minimum requirements. The basis is to prevent an immediate demand to trip upon low burner pressure at startup.</p> <p>NOTE Minimum fuel gas header pressure may be a permissive to light the pilots and main fuel gas.</p>
5	<p>Confirm that burner air registers are open (e.g. visually), combustion air dampers and stack dampers are fully open (e.g. via position indication).</p> <p>NOTE Note: Proof of dampers open is a purge permissive</p>
6	<p>Reset manual shutdown pushbuttons/switches and alarms at local panel/control room.</p>
7	<p>Establish balanced process flow through heater passes per operating procedures.</p> <p>NOTE Minimum pass flow(s) may not be a permissive to light the pilots (e.g. to facilitate refractory curing), but is a permissive to introduce main fuel gas.</p>
8	<p>Set the variable inlet vanes on the forced draft fan to the startup position, insure all air from the fan will reach the heater firebox, start the fan. Initiate the purge cycle (see 3.4.7.3).</p>
9	<p>When the purge cycle is complete, consider a portable LEL detector to sniff at predetermined locations to confirm that combustibles are not present. This is more relevant for natural draft heaters with a cold firebox.</p>
10	<p>Confirm that air registers and fuel gas control valves are in light-off positions. Where applicable, stack damper should remain fully open.</p>
11	<p>When the purge cycle is complete (sequence permissive), manually command the pilot gas shutoff valves to open. This can be in the form of a manual reset or pushbutton. A pilot trial-for-ignition timer may or may not be used for this step.</p> <p>NOTE 1 Some applications use a manual reset solenoid valve. For these applications, solenoid construction with a lever that cannot be defeated is recommended.</p> <p>NOTE 2 For applications that use double block and bleed on pilot gas, it is recommended that the bleed valve is confirmed closed before the double block valves open. The basis is to mitigate blowing fuel gas to atmosphere. Should the bleed valve open or fail to prove closed during the startup sequence, a manual isolation valve beneath the bleed valve may be considered to continue the light off sequence.</p> <p>NOTE 3 A startup override of the low pilot gas pressure trip is typically required to permit opening of the pilot gas block valves. Otherwise, the low pressure condition at startup below the trip setpoint would not allow the block valves to be sequenced open. Once the pilot pressure is confirmed above the low pressure trip setpoint for a fixed time interval, the logic solver will typically activate the low pressure protective function.</p>
12	<p>Confirm that pilot gas pressure (i.e. downstream of the regulator and safety shutoff valves) is within the operating or flame stability limits of the pilot.</p> <p>NOTE If pilot gas cock valves are closed, the pilot gas regulator may creep to header pressure. In this case, the pilot gas header pressure should be reduced (e.g. vented to flare) within operating limits prior to light off.</p>
13	<p>Light off each pilot independently.</p> <p>NOTE 1 For multiple pilots, it is typically recommended to light one pilot at a time. If a pilot fails to light (typically within 10 seconds to 15 seconds), that pilot should be isolated prior to troubleshooting. Allow that pilot area to purge itself prior to a relight attempt. The basis is to ensure the unburned fuel gas concentration in the firebox is not permitted to exceed 25 % of the LEL during light off; otherwise a re-purge is required.</p> <p>NOTE 2 If pilot gas pressure does not remain within the operating or flame stability limits during light off, a high/low pilot gas pressure protective function should trip the safety shutoff valves in which case the purge cycle should be repeated.</p>

Table 5—Startup Sequence, Forced Draft and Balanced Draft Heaters (Continued)

Step	Action
14	Complete light off for pilots, and confirm pilots are lighted via visual confirmation or electronic flame monitoring.
15	<p>Manually command the main fuel gas shutoff valves to open. This can be in the form of a manual reset or pushbutton. A main burner trial-for-ignition timer may or may not be used for this step.</p> <p>NOTE 1 Some applications use a manual reset solenoid valve. For these applications, solenoid construction with a lever that cannot be defeated is recommended.</p> <p>NOTE 2 A startup override of the low fuel gas burner pressure trip is typically required to permit opening of the main fuel gas block valves. Otherwise, the low pressure condition at startup below the trip setpoint would not allow the block valves to be sequenced open. Once the burner pressure is confirmed above the low pressure trip setpoint for a fixed time interval, the logic solver will typically activate the low pressure protective function.</p>
16	<p>For applications that use double block and bleed on main fuel gas, it is recommended that the bleed valve is confirmed closed before the double block valves open. The basis is to mitigate blowing fuel gas to atmosphere.</p> <p>NOTE Should the bleed valve open or fail to prove closed during the startup sequence, a manual isolation valve beneath the bleed valve may be considered to continue the light off sequence</p>
17	<p>Confirm that the fuel gas control valve is in the light off position and that the burner pressure is controlled at light off pressure. Light the burner(s) per standard operating procedures (SOP).</p> <p>NOTE 1 Fuel gas pressure may rise to header pressure when main burner cock valves are closed. In this case, the pressure should be reduced (e.g. vented to flare) within the operating limits prior to light off.</p> <p>NOTE 2 Where the control valve has insufficient turndown to light off the first few burners, alternate considerations (see Section 3.3.1) to maintain the desired light off pressure may include a minimum flow orifice or a minimum fire regulator. Each startup device is typically sized to light the first few burners until the control valve is within control range. Each must be installed in parallel with the fuel gas control valve. Neither is permitted to bypass the safety shutoff valves.</p>
18	<p>Light the main burners individually.</p> <p>NOTE 1 For multiple burners, it is typically recommended to light one burner at a time. If a burner fails to light (typically within 10 seconds to 15 seconds), that burner should be isolated prior to troubleshooting. Allow that burner area to purge itself prior to a relight attempt. The basis is to ensure the unburned fuel gas concentration in the firebox is not permitted to exceed 25 % of the LEL during light off; otherwise a re-purge is required.</p> <p>NOTE 2 If burner gas pressure does not remain within the operating or flame stability limits during light off, a high/low fuel gas pressure protective function should trip the safety shutoff valves in which case the purge cycle should be repeated (except where continuous pilots provide hot restart capability)</p>
19	Light as many burners as required to achieve the desired startup heating requirements ensuring that burner pressure stays within the operating or flame stability limits.
20	Set the fuel gas controller to automatic mode (release to modulate) when appropriate.

Annex A **(normative)**

Tube Rupture Considerations

Tube rupture is a hazard that can result in an uncontrolled fire and/or explosion in the heater.

Fires typically result with non-explosive mediums such as oils and heavy fluids, where accumulation of explosive gas is prevented, and where the operating pressure is not sufficient to violate the mechanical integrity of the heater structure (flame front velocity/force).

Further, these are typically contained within the heater and cause burning out the stack or ports on low pressure cases. If enough fluid leaks out, some burning liquid may spill over and cause burning on the ground exterior to the heater.

Major leaks and elastic or multiple tube failures may result in significant internal and external damage to the heater.

Heaters which have vessels downstream which operate at high pressures are at risk of having the reactor pressure blow back into the heater. Consider the installation of a check valve or automated isolation valve(s) to avoid catastrophic structural damage.

Very high pressure process mediums (generally 1500 psig and above) may have potential for a flame front with sufficient velocity and force to violate heater mechanical integrity and therefore expose personnel outside of the heater to safety risks.

Heaters which have explosive or highly flammable gases like butane, pentane, hydrogen, H₂S, gasoline, etc. may have a potential for accumulation and explosion under certain circumstances.



AMERICAN PETROLEUM INSTITUTE

**2011
PUBLICATIONS
ORDER FORM**

Effective January 1, 2011. API Members receive a 30% discount where applicable. The member discount does not apply to purchases made for the purpose of resale or for incorporation into commercial products, training courses, workshops, or other commercial enterprises.

Online Orders www.api.org/pubs
Phone Orders **1-800-854-7179** (Toll-free in the U.S. and Canada) | **(+1) 303-397-7956** (Local and International)
Fax Orders **(+1) 303-397-2740**

Date: _____

API Member (Check if Yes)

Invoice To (Check here if same as "Ship To")

Name: _____
 Title: _____
 Company: _____
 Department: _____
 Address: _____

 City: _____ State/Province: _____
 Zip/Postal Code: _____ Country: _____
 Telephone: _____
 Fax: _____
 Email: _____

Ship To (UPS will not deliver to a P.O. Box)

Name: _____
 Title: _____
 Company: _____
 Department: _____
 Address: _____

 City: _____ State/Province: _____
 Zip/Postal Code: _____ Country: _____
 Telephone: _____
 Fax: _____
 Email: _____

Quantity	Title	SO★	Unit Price	Total

Payment Enclosed P.O. No. (Enclose Copy) _____
 Charge My IHS Account No. _____
 VISA MasterCard American Express
 Diners Club Discover
 Credit Card No.: _____
 Print Name (As It Appears on Card): _____
 Expiration Date: _____
 Signature: _____

Subtotal	
Applicable Sales Tax (see below)	
Rush Shipping Fee (see below)	
Shipping and Handling (see below)	
Total (in U.S. Dollars)	

★ To be placed on Standing Order for future editions of this publication, place a check mark in the SO column and sign here:

Pricing and availability subject to change without notice.

Mail Orders – Payment by check or money order in U.S. dollars is required except for established accounts. State and local taxes, \$10 processing fee, and 5% shipping must be added. Send mail orders to: **API Publications, IHS, 15 Inverness Way East, c/o Retail Sales, Englewood, CO 80112-5776, USA.**
Purchase Orders – Purchase orders are accepted from established accounts. Invoice will include actual freight cost, a \$10 processing fee, plus state and local taxes.
Telephone Orders – If ordering by telephone, a \$10 processing fee and actual freight costs will be added to the order.
Sales Tax – All U.S. purchases must include applicable state and local sales tax. Customers claiming tax-exempt status must provide IHS with a copy of their exemption certificate.
Shipping (U.S. Orders) – Orders shipped within the U.S. are sent via traceable means. Most orders are shipped the same day. Subscription updates are sent by First-Class Mail. Other options, including next-day service, air service, and fax transmission are available at additional cost. Call 1-800-854-7179 for more information.
Shipping (International Orders) – Standard international shipping is by air express courier service. Subscription updates are sent by World Mail. Normal delivery is 3-4 days from shipping date.
Rush Shipping Fee – Next Day Delivery orders charge is \$20 in addition to the carrier charges. Next Day Delivery orders must be placed by 2:00 p.m. MST to ensure overnight delivery.
Returns – All returns must be pre-approved by calling the IHS Customer Service Department at 1-800-624-3974 for information and assistance. There may be a 15% restocking fee. Special order items, electronic documents, and age-dated materials are non-returnable.

THERE'S MORE WHERE THIS CAME FROM.

API Monogram® Licensing Program

Sales: (+1) 713-964-2662
Service: (+1) 202-962-4791
Fax: (+1) 202-682-8070
Email: certification@api.org
Web: www.api.org/monogram

API Quality Registrar (APIQR®)

- ISO 9001
- ISO/TS 29001
- ISO 14001
- OHSAS 18001
- API Spec Q1®
- API QualityPlus®
- Dual Registration

Sales: (+1) 713-964-2662
Service: (+1) 202-962-4791
Fax: (+1) 202-682-8070
Email: certification@api.org
Web: www.api.org/apiqr

API Individual Certification Programs (ICP®)

Sales: (+1) 713-964-2662
Service: (+1) 202-682-8064
Fax: (+1) 202-682-8348
Email: icp@api.org
Web: www.api.org/icp

API Engine Oil Licensing and Certification System (EOLCS)

Sales: (+1) 713-964-2662
Service: (+1) 202-682-8516
Fax: (+1) 202-962-4739
Email: eolcs@api.org
Web: www.api.org/eolcs

API Training Provider Certification Program (API TPCP™)

Sales: (+1) 713-964-2662
Service: (+1) 202-682-8075
Fax: (+1) 202-682-8070
Email: tpcp@api.org
Web: www.api.org/tpcp

API Perforator Design Registration Program

Sales: (+1) 713-964-2662
Service: (+1) 202-682-8490
Fax: (+1) 202-682-8070
Email: perfdesign@api.org
Web: www.api.org/perforators

API Credit Exchange (ACE™)

Service: (+1) 202-682-8192
Fax: (+1) 202-682-8070
Email: exchange@api.org
Web: www.api.org/ace

API Diesel Exhaust Fluid Certification Program

Phone: (+1) 202-682-8516
Fax: (+1) 202-962-4739
Email: info@apidef.org
Web: www.apidef.org

API WorkSafe™

Sales: (+1) 713-964-2662
Service: (+1) 202-682-8469
Fax: (+1) 202-682-8348
Email: apiworksafe@api.org
Web: www.api.org/worksafe

API-U

Phone: (+1) 202-682-8053
Fax: (+1) 202-682-8070
Email: training@api.org
Web: www.api-u.org

API Data™

Phone: (+1) 202-682-8499
Fax: (+1) 202-962-4730
Email: apidata@api.org
Web: www.APIDataNow.org

API Publications

Online: www.api.org/pubs
Phone: 1-800-854-7179
(Toll-free: U.S./Canada)
(+1) 303-397-7956
(Local/International)
Fax: (+1) 303-397-2740

API Standards

Phone: (+1) 202-682-8148
Fax: (+1) 202-962-4797
Email: standards.org
Web: www.api.org/standards

Request a Quotation:
www.api.org/quote



AMERICAN PETROLEUM INSTITUTE



AMERICAN PETROLEUM INSTITUTE

1220 L Street, NW
Washington, DC 20005-4070
USA

202-682-8000

Additional copies are available online at www.api.org/pubs

Phone Orders: 1-800-854-7179 (Toll-free in the U.S. and Canada)
303-397-7956 (Local and International)
Fax Orders: 303-397-2740

Information about API publications, programs and services is available
on the web at www.api.org.

Product No. C55602