

Manual of Petroleum Measurement Standards Chapter 4—Proving Systems

Section 9—Methods of Calibration for Displacement and Volumetric Tank Provers

Part 2—Determination of the Volume of Displacement and Tank Provers by the Waterdraw Method of Calibration

FIRST EDITION, DECEMBER 2005

REAFFIRMED, JULY 2015



AMERICAN PETROLEUM INSTITUTE

Manual of Petroleum Measurement Standards Chapter 4—Proving Systems

**Section 9—Methods of Calibration for
Displacement and Volumetric Tank
Provers**

**Part 2—Determination of the Volume of
Displacement and Tank Provers by the
Waterdraw Method of Calibration**

Measurement Coordination

FIRST EDITION, DECEMBER 2005

REAFFIRMED, JULY 2015



AMERICAN PETROLEUM INSTITUTE

SPECIAL NOTES

API publications necessarily address problems of a general nature. With respect to particular circumstances, local, state, and federal laws and regulations should be reviewed.

Neither API nor any of API's employees, subcontractors, consultants, committees, or other assignees make any warranty or representation, either express or implied, with respect to the accuracy, completeness, or usefulness of the information contained herein, or assume any liability or responsibility for any use, or the results of such use, of any information or process disclosed in this publication. Neither API nor any of API's employees, subcontractors, consultants, or other assignees represent that use of this publication would not infringe upon privately owned rights.

API publications may be used by anyone desiring to do so. Every effort has been made by the Institute to assure the accuracy and reliability of the data contained in them; however, the Institute makes no representation, warranty, or guarantee in connection with this publication and hereby expressly disclaims any liability or responsibility for loss or damage resulting from its use or for the violation of any authorities having jurisdiction with which this publication may conflict.

API publications are published to facilitate the broad availability of proven, sound engineering and operating practices. These publications are not intended to obviate the need for applying sound engineering judgment regarding when and where these publications should be utilized. The formulation and publication of API publications is not intended in any way to inhibit anyone from using any other practices.

Any manufacturer marking equipment or materials in conformance with the marking requirements of an API standard is solely responsible for complying with all the applicable requirements of that standard. API does not represent, warrant, or guarantee that such products do in fact conform to the applicable API standard.

All rights reserved. No part of this work may be reproduced, stored in a retrieval system, or transmitted by any means, electronic, mechanical, photocopying, recording, or otherwise, without prior written permission from the publisher. Contact the Publisher, API Publishing Services, 1220 L Street, N.W., Washington, D.C. 20005.

FOREWORD

This multi-part publication consolidates and standardizes calibration procedures for displacement and volumetric tank provers used in the metering of petroleum liquids. It provides essential information on the operations involved in obtaining a valid, accurate and acceptable prover volume by different calibration methods. Units of measure in this publication are in the International System (SI) and United States Customary (USC) units consistent with North American industry practices. Part 1 is the introduction and contains those aspects that are generic to the various methods of calibration, including waterdraw (WD), master meter (MM) and gravimetric (GM). Each subsequent part is intended to be used in conjunction with Part 1 for the particular calibration procedure described. This section consists of the following four parts:

Part 1 – “Introduction to the Determination of the Volume of Displacement and Tank Provers”

Part 2 – “Determination of the Volume of Displacement and Tank Provers by the Waterdraw Method of Calibration”

Part 3 – “Determination of the Volume of Displacement Provers by the Master Meter Method of Calibration”

Part 4 – “Determination of the Volume of Displacement Provers by the Gravimetric Method of Calibration”

This standard was developed through the cooperative efforts of many individuals from the petroleum industry, under the sponsorship of the American Petroleum Institute.

Nothing contained in any API publication is to be construed as granting any right, by implication or otherwise, for the manufacture, sale, or use of any method, apparatus, or product covered by letters patent. Neither should anything contained in the publication be construed as insuring anyone against liability for infringement of letters patent.

This document was produced under API standardization procedures that ensure appropriate notification and participation in the developmental process and is designated as an API standard. Questions concerning the interpretation of the content of this publication or comments and questions concerning the procedures under which this publication was developed should be directed in writing to the Director of Standards, American Petroleum Institute, 1220 L Street, N.W., Washington, D.C. 20005. Requests for permission to reproduce or translate all or any part of the material published herein should also be addressed to the director.

Generally, API standards are reviewed and revised, reaffirmed, or withdrawn at least every five years. A one-time extension of up to two years may be added to this review cycle. Status of the publication can be ascertained from the API Standards Department, telephone (202) 682-8000. A catalog of API publications and materials is published annually and updated quarterly by API, 1220 L Street, N.W., Washington, D.C. 20005.

Suggested revisions are invited and should be submitted to the Standards and Publications Department, API, 1220 L Street, NW, Washington, DC 20005, standards@api.org.

CONTENTS

	Page
1.0 INTRODUCTION	1
1.1 U.S. Customary And Metric (Si) Units	1
1.2 National Weights and Measures Agencies	1
1.3 Safety Considerations	1
2.0 SCOPE	1
3.0 REFERENCE PUBLICATIONS	1
4.0 TERMS AND APPLICATIONS	2
4.1 TERMS	2
4.2 APPLICATIONS	2
5.0 PROVER CLEANING AND PREPARATION	3
5.1 Isolation of the Prover	3
5.2 Initial Prover Preparation	3
5.3 Purging and Cleaning of the Prover	4
5.4 Sphere Displacer Inspection, Sizing and Preparation	4
5.5 Water Filling, Venting and Circulation of Pipe Provers	7
6.0 PRELIMINARY AND GENERAL CALIBRATION PROCEDURES	7
6.1 General Calibration Discussion	7
6.2 Displacement Type Unidirectional Provers with Free Displacers	18
6.3 Displacement Type Bi-directional Provers with Free Displacers	19
6.4 Displacement Type Meter Provers with Captive Displacers	21
6.5 Atmospheric Tank Provers	22
7.0 CALIBRATION PROCEDURES BY TYPE OF PROVER	26
7.1 Calibration Preparation	26
7.2 Displacement Type Unidirectional Provers with Free Displacers	27
7.3 Displacement Type Bi-directional Provers with Free Displacers	28
7.4 Displacement Type Meter Provers with Captive Displacers	30
7.5 Atmospheric Tank Provers	32
8.0 TROUBLESHOOTING CALIBRATION PROBLEMS	35
8.1 Evaluation of Calibration Results	35
8.2 Leaks	36
8.3 Prover Detector Switches	36
8.4 Sphere Interchanges	36
8.5 Four-Way Valves	36
8.6 Displacers	37
8.7 Drains and Vents	38
8.8 Temperature and Pressure	38
8.9 Pumps, Hoses and Connections	39
8.10 Detector Switches, Solenoids and Logic Circuits	39
8.11 Field Standard Test Measures	39
8.12 Piping and Manifolds	39
8.13 Water Quality	40

CONTENTS

	Page
8.14 Air and Entrained Gas	40
8.15 Prover Conditions and Coatings.	40
APPENDIX A (INFORMATIVE) UNCERTAINTIES IN METER PROVER CALIBRATIONS	41
APPENDIX B (NORMATIVE) EFFECTS OF TEMPERATURE CHANGES ON THE INTERFACE INVENTORY.	49
APPENDIX C (INFORMATIVE) EXAMPLES OF WATERDRAW DATA SHEETS .	53
APPENDIX D (INFORMATIVE) FIELD STANDARD TEST MEASURES	75

Figures

A.1 Uncertainty Analysis: Detector Switch Actuation Point with Respect to the Forward Movement of the Prover Sphere	42
1 Schematic Drawing of a Typical Layout for a Waterdraw Calibration of a Displacement Type Unidirectional Prover with a Free Displacer using Top-filling Test Measures	83
2A Schematic Drawing of a Typical Layout for a Waterdraw Calibration of a Displacement Type Bi-directional Prover with a Free Piston Displacer and Check Valves in the Manifold using Top-filling Test Measures. . .	84
2B Schematic Drawing of a Typical Layout for a Waterdraw Calibration of a Displacement Type Bi-directional Prover with a Free Sphere Displacer using Top-filling Test Measures.	85
3A Schematic Drawing of a Typical Layout for a Waterdraw Calibration of the Downstream Volume of a Displacement Prover with a Captive Displacer and External Detectors using Top-filling Test Measures.	86
3B Schematic Drawing of a Typical Layout for a Waterdraw Calibration of the Upstream Volume of a Displacement Prover with a Captive Displacer and External Detectors using Top-filling Test Measures.	87
3C Schematic Drawing of a Typical Layout for a Waterdraw Calibration of a Displacement Prover with Equal Size Diameter Shafts on Both Sides of a Captive Displacer and External Detectors using Top-filling Test Measures .	88
4A Schematic Drawing of a Typical Layout for a Waterdraw Calibration of a Volumetric Tank Prover with a Bottom Weir using Top-filling Test Measures . .	89
4B Schematic Drawing of a Typical Layout for a Waterdraw Calibration of a Volumetric Tank Prover with a Dry Bottom using the Water-fill Method and using Top-filling Test Measures.	90
4C Schematic Drawing of a Typical Layout for a Waterdraw Calibration of a Volumetric Tank Prover with a Wet Bottom using Top-filling Test Measures . . .	91
5 Alternate Method—Schematic Drawing of a Typical Layout for a Waterdraw Calibration of a Proving System using Bottom-filling Test Measures	92

CONTENTS

	Page
Tables	
1 Sphere Ovality Verification	5
2 Sphere Sealing Width Relationships.	7
A-1 Detector Switch, Sphere and Pipe Diameter Uncertainty	44
A-2 Uncertainty Due to Test Measure Combination	45
A-3 Estimated Uncertainty of Prover Calibration Runs (at the 95% confidence level)	46
A-4 Assumed Values from A.1, A.2 and A.3 for illustration purposes only	47
B-1 Temperature Difference in Interface Inventory	49
B-2	50
D-1 Test Measure Discharge Times Based on Volume and Drain Size	76
D-2 Normal and High Sensitivity Test Measures Interpolation of Volumes between the Lowest Scale Lines on Field Standard Test Measures	77
D-3 Example of Test Measures Available on Waterdraw Unit	78

Chapter 4—Proving Systems

Section 9—Methods of Calibration for Displacement And Volumetric Tank Provers

Part 2—Determination of the Volume of Displacement and Tank Provers by the Waterdraw Method of Calibration

1.0 Introduction

All prover volumes used to calibrate meters shall be determined by calibration and not by theoretical calculation. Volumetric provers have an exact reference volume, which has been determined by a recognized method of calibration. Techniques for the determination of this reference volume include the waterdraw, master meter and gravimetric methods of calibration. This standard describes only the waterdraw method of calibration, which is used to accurately determine the calibrated volume of both displacement and tank provers.

1.1 U.S. CUSTOMARY AND METRIC (SI) UNITS

This standard presents both International System (SI) and U.S. Customary (USC) units, and may be implemented in either system of units. The system of units to be used is typically determined by contract, regulatory requirement, the manufacturer, or the user's calibration program. Once a system of units is chosen for a given application, it is not the intent of this standard to allow the arbitrary changing of units within this standard.

1.2 NATIONAL WEIGHTS AND MEASURES AGENCIES

Throughout this document issues of traceability are addressed by references to NIST (National Institute of Standards and Technology). However, other appropriate national metrology institutes can be referenced.

1.3 SAFETY CONSIDERATIONS

There is no intent to cover safety aspects of conducting the work described in this standard, and it is the duty of the user to be familiar with all applicable safe work practices. It is also the duty of the user to comply with all existing federal, state or local regulations (for example, the Occupational Safety and Health Administration) that govern the types of activities described in this standard, and to be familiar with all such safety and health regulations.

2.0 Scope

This standard covers all the procedures required to determine the field data necessary to calculate a Base Prover Volume (BPV), of either Displacement Provers or Volumetric Tank Provers, by the Waterdraw Method of Calibration.

It will enable the user to perform all the activities necessary to prepare the prover, conduct calibration runs, and record all the required data necessary to calculate the base volumes of displacement and tank provers. Evaluation of the results and troubleshooting of many calibration problems are also discussed.

Detailed calculation procedures are not included in this standard. For complete details the of calculations applicable to this standard, refer to the latest edition of the *API Manual of Petroleum Measurement Standards*, Chapter 12, Section 2, Part 4, "Calculation of Prover Volumes by the Waterdraw Method."

3.0 Reference Publications

Publications that provided background information, and are a source of reference material on subjects related to waterdraw calibration include the following:

American Petroleum Institute

Manual of Petroleum Measurement Standards (MPMS)

- Chapter 1 "Vocabulary"
- Chapter 4 "Proving Systems"
- Chapter 5 "Metering"
- Chapter 7 "Temperature Determination"

Chapter 11	“Physical Properties Data”
Chapter 12	“Calculation of Petroleum Quantities”
Chapter 13	“Statistical Aspects of Measuring and Sampling
Chapter 15	“Guidelines for Use of the International System of Units (SI) in the Petroleum and Allied Industries”

NIST¹

Handbook 105	<i>Specifications and Tolerances for Reference Standards and Field Standard Weights and Measures</i>
Part 3	<i>Specifications and Tolerances for Graduated Neck-Type Volumetric Field Standards</i>
Part 7	<i>Small Volume Provers</i>
Handbook 44	<i>Specifications, Tolerances and Other Technical Requirements for Weighing and Measuring Devices</i>

4.0 Terms And Applications

There are no definitions unique to this document. However, the publications selected in section 3.0 may be referenced for definitions relating to the calibration of displacement and tank provers by the waterdraw method. Terms and symbols described below are acceptable and in common use for the calibration of meter provers.

4.1 TERMS

4.1.1 cessation of main flow: The moment when the full discharging water stream “breaks” and becomes a small trickle during the draining of a field standard test measure.

4.1.2 clingage: The film of liquid that adheres to the inside surface of a field standard test measure after it has been drained and is considered empty.

4.1.3 drain time: A fixed time period for completing the draining of a field standard test measure that is calibrated on a “to deliver” basis, as described on the Report of Calibration by the calibrating agency. The draining period starts at the cessation of main flow, and has the same duration as the draining time established when the test measure was calibrated.

4.1.4 field standard test measure: A vessel (usually of stainless steel) fabricated to meet a vigorous design criteria and specification, that is used as the basic standard of volume in the waterdraw calibration of volumetric provers. After calibration by NIST or another appropriate national metrology institute the test measure has a precise volume that is used to calculate the base volume of the prover under test.

4.1.5 “to contain” volume: A method of characterization of a field standard test measure, that determines its volume, at reference temperature, when it is filled from a clean, dry, empty, condition. This volume is not utilized in the waterdraw calibration of provers.

4.1.6 “to deliver” volume: A method of characterization of a field standard test measure, that determines its volume, at reference temperature, when it is emptied from its full condition, and drained in accordance with the prescribed draining time. This volume is utilized in the waterdraw calibration of provers.

4.1.7 waterdraw: A method of calibrating a meter prover by displacing water from the prover into field standard test measures.

4.2 APPLICATIONS

The waterdraw method of prover calibration is based on the drawing of water from a displacement prover into field standard test measures. For open tank provers, the waterdraw method may use either the drawing of water from the tank prover into the field standard test measures or alternatively by filling of the tank prover from the test measures. In all cases an up to date volume certification of each field standard test measure to be used in the calibration, with an acceptable calibrated volume uncertainty, must be provided and be traceable to NIST or other appropriate national metrology institutes.

¹National Institute of Standards and Technology, 1655 N Ft. Myer Drive, Suite 700, Arlington, Virginia, 22209. www.nist.gov.

5.0 Prover Cleaning And Preparation

5.1 ISOLATION OF THE PROVER

The prover and its auxiliary piping shall be isolated from all operating systems by either physical isolation with blinds, blind flanges, blanks, spectacles or double block and bleed valves to separate it from the upstream and downstream operating line pressures and products. A complete visual inspection should be made of the entire prover system to assure that the system is properly isolated.

5.2 INITIAL PROVER PREPARATION

New or repaired provers are generally hydrostatically tested prior to placing into service. When a hydrostatic test is required, it shall be conducted prior to the waterdraw calibration. This ensures that the calibrated volume will not be altered by permanent pipe expansion, subsequent tightening of flanges, etc. Piston provers shall be waterdrawn using the same piston design and seals, both material and style, that are utilized in the prover's normal meter proving operation. Substitution of spheres for the piston during calibration shall not be allowed.

Connections to pipe work or flexible hoses are required for water circulation through the prover. These are typically 2 in. threaded connections, which should be as close to the calibrated section as practical. (If vents and drains are being considered for waterdraw connections, their location should ensure that all the water used in the calibration will be circulated through the entire proving system. This is necessary to maintain constant temperature in the calibration water.) Adequate water flow is required to launch the displacer in a pipe prover.

High point vent valves should be inspected. If damaged, defective or leaking they should be repaired or replaced prior to the calibration. Vent valves, in good working order, are necessary for all prover calibrations, to ensure that all air or vapor has been vented from the prover prior to the start of each calibration pass.

Before a prover calibration, all relief valves should be removed, checked for leakage, repaired and re-calibrated as necessary. If in place during the prover calibration then the relief valves should be isolated. If not isolated they must be disconnected from the drain system and regular visual checks for any leakage shall be made.

Drain valves, either on the prover itself, or in manifolds and pipe-work connected to the prover but not isolated from it, must all be inspected for leakage and either sealed off or left uncoupled to enable a visual determination of any leakage during the calibration runs.

Calibration of a prover with the sphere launching interchange or four-way valve isolated does not verify the integrity of operation of the complete proving system. Rather, it simply calibrates the volume contained in a pipe between two switches, which may or may not be acceptable to all the parties concerned.

Depending upon the type of prover to be calibrated the following operations should be performed:

- On a bi-directional prover if its four-way valve is to be used in the calibration process, it shall be checked for condition, smoothness of operation, verify that the seals are holding and ascertain that the valve is leak free. A final check should be made after the prover has been cleaned.
- On a unidirectional prover, if its interchange is to be used in the calibration process, it shall be verified that it is operating correctly, sealing fully, and is leak free. A final check should be made after the prover has been cleaned.
- On provers with captive displacers, a seal leak verification test should be performed. Replace any seals as necessary. Make sure all waterdraw programs and or control boards are present, installed, and working correctly. Any valves or valve systems located internally in the piston, in the prover body itself or in any of the associated pipe-work should be verified and tested. Consult the manufacturer's recommendations for all specifications, leak testing procedures and calibration procedures.
- In piston provers, check the condition of the piston seals and any signs of corrosion on the metal piston itself. Repair or replace as required. Verify the integrity of any valve in the body of the piston. In a free displacer piston prover, check the condition of the piston to ensure that there are no cracks, excessive wear on the wear rings, or other physical changes to the piston that would affect the waterdraw calibration or would cause damage to the prover coating. Free piston displacer seal outer diameters are typically 3 – 5% greater than the pipe inside diameter, and it is recommended that they be no less than 2% oversize.
- On atmospheric tank type provers, block off the vapor recovery system. For wet bottom types make sure there is a hose connection below the "zero" mark. For dry bottom types the connection should be on the downstream side of the block valve.

While the tank prover is full of water, verify that it is level in two axes of a horizontal plane, before beginning the calibration.

Check all prover detector switches to make sure they are in good operating condition. Mechanical detectors may need to be dismantled, cleaned, inspected, repaired and re-assembled as part of the normal preparation for the calibration of a prover. In some cases it may be advantageous to completely replace the detector switches prior to a calibration. As a guide, do all that is necessary to ensure that the detector switches are in good working condition prior to the prover calibration.

5.3 PURGING AND CLEANING OF THE PROVER

Provers in batched crude oil service should be purged with the least viscous available crude unless there is on-site availability of other light hydrocarbon products that can be used. Regardless of service the prover and associated piping shall be cleaned by the best means available and flushed with water until free of all traces of hydrocarbon liquids and solids. Valves may need to be operated to ensure that no hydrocarbon remains. The most widely used method is running the prover displacer back and forth during the water-flush to scrub the walls. Another method, used in crude oil service is to use a hot oil truck to circulate hot water through the prover while pushing the displacer back and forth. When available, steam cleaning is a method for removing wax, paraffin, etc. Pull-through foam pipeline pigs can also be used as an alternative or an additional method of cleaning the interior of pipe provers. Caution should be taken to prevent damage to the internal coating during the cleaning process.

While a detergent can be effective in cleaning a prover, all traces of it must be removed prior to the calibration to prevent foaming. This can sometimes be very difficult to achieve. Therefore, the use of detergents is discouraged except in extreme cases. If it is decided that a detergent has to be used, only a non-suds type should be considered. Even then, it may take a great amount of water to fully remove all traces of the detergent. Nonetheless, all traces of the presence of any detergent must be totally removed before beginning the waterdraw calibration.

LPG pipe provers are best cleaned by filling with water and moving the displacer back and forth to scrub the walls. It is recommended that the prover be drained, refilled and then allowed to stand overnight. The prover is then drained and flushed with clean water. Experience has demonstrated that this procedure eliminates LPG vapors from the piping that can become entrained in the water during the calibration.

After cleaning and while the prover is open, check the condition of the internal surfaces of the prover particularly the condition of the coating. Visual, or mechanical inspection, of the surface areas for any signs of damage, flaking, or missing coating, shall all be carefully examined. Any observations of irregularities in the quality of the internal condition of the prover or any other internal damage shall be carefully assessed and a determination made on its effect on continuing the calibration.

5.4 SPHERE DISPLACER INSPECTION, SIZING AND PREPARATION

Prior to inspection the prover sphere has to be removed from the prover. In order to remove the sphere displacer, send it to the appropriate end chamber if the prover is bi-directional, or to the sphere handling interchange if the prover is unidirectional. Then drain the prover and remove the access cover. Provided the sphere is in place it can be removed either by hand or mechanical means depending upon its size.

Sometimes it will be found that the sphere has not in fact arrived in the chamber but is further back in the prover barrel. If this happens only one procedure is permissible: replace the cover securely, refill the prover, and start again. Under no circumstances shall any attempt be made to force the displacer out with compressed air or gas.

Once the prover sphere has been removed, check the condition to make sure it does not have deep cuts, rips, extreme pitting, holes, flat spots, soft spots, or overall poor condition that may cause leaks or loss of seal. After careful inspection, a decision on its suitability for further use should be made.

The durometer (hardness) and composition of the sphere should be considered as part of prover design. Different hardness and materials can have an effect on both normal operations and calibration, so these must be considered in the design to accommodate both. Because of the lower lubricity of water and greatly reduced flow rates encountered during waterdraw calibrations, a softer durometer sphere usually has a better performance during calibrations. Harder durometer spheres have a difficult time creating a capillary seal inside a prover with anything less than excellent interior coating and round pipe. Conversely, caution should be taken to ensure that the durometer of the sphere is not too soft, otherwise it might have a hard time compressing the spring on the detector switch probe.

Verify the ovality or roundness of the sphere by determining its circumference around two separate axes perpendicular to each other. A circumference variation in the sphere, that is the difference in length around these two perpendicular axes of more than one percent of the nominal circumference, is considered out-of-round. Measuring the sphere, first around its equator, and then around its polar axis usually across the two valve holes, and comparing the difference between the two measurements according to Table 1 will verify sphere roundness. Manufacturing tolerances for new spheres may be up to 1.5%.

Examples of Sphere Ovality Verification:

A 6 in. sphere that is considered to be round, with a nominal diameter of 6.065 in. would be expected to have a diameter variation no greater than $1/16$ in. and a circumference variation no greater than $3/16$ in. Alternatively, a 30 in. sphere with a nominal diameter of 29.250 in. would be expected to have a diameter variation no greater than $9/32$ in. and a circumference variation no greater than $29/32$ in. The comparison measurements in all cases shall be taken around two perpendicular axes of the sphere.

Table 1—Sphere Ovality Verification

Standard Wall Prover Pipe ID (Inches)	Maximum Diameter Variation (Inches)	Maximum Circumference Variation (Inches)
6.065	$1/16$	$3/16$
7.981	$3/32$	$1/4$
10.020	$3/32$	$5/16$
12.000	$1/8$	$3/8$
13.250	$1/8$	$13/32$
15.250	$5/32$	$15/32$
17.250	$3/16$	$17/32$
19.250	$3/16$	$19/32$
21.250	$7/32$	$21/32$
23.250	$7/32$	$23/32$
25.250	$1/4$	$25/32$
27.250	$9/32$	$27/32$
29.250	$9/32$	$29/32$
35.000	$11/32$	$1-3/32$
41.000	$13/32$	$1-9/32$
47.000	$15/32$	$1-15/32$

After the sphere has been inspected and checked, assuming it has passed all the requirements, it can now be prepared for reinstallation by sizing it. The sphere should be sized by an amount greater than the internal diameter of the pipe depending upon circumstances and/or company policies. The magnitude of the sphere over-sizing depends upon the diameter of the pipe, the material of the sphere, the condition of the internal coating and/or the pipe itself. Spheres are generally over-sized in the range of 2 – 5%. Greater over-sizing may be necessary when conditions warrant. However, the need for excessive over-sizing can sometimes be symptomatic of internal problems and irregularities in the prover. The displacer should be sized; large enough to prevent water leakage around the sphere, and small enough to minimize excessive friction and pressure drop.

A liquid (e.g., water, glycol, or a water/glycol mixture) is pumped into the sphere using a small hand pump supplied by the prover manufacturer and the circumference measured until the required size is obtained. For best results a sphere with two inflation valves should be used. Air must be eliminated from the interior of the sphere during the filling by pumping the liquid through the bottom valve of the sphere while displacing the air out through the top valve cavity with the core removed. During final sizing, to ensure that all air is displaced, the sphere is completely filled with liquid. Then the top valve core is reinstalled, and pumping into the sphere is continued until the sphere is sufficiently oversized with the liquid under pressure. The sphere is then vented to the correct size using the top valve. The process of overfilling and venting may need to be repeated several times. Single valve spheres can sometimes be initially filled by removing the valve core and inserting a small tube into the cavity for filling. Once the sphere is essentially full, the procedure would be the same as for a sphere with two valves.

Sizing of the prover sphere is accomplished by one of three general methods, although any other accepted method may be used.

- Set of calipers with openings sufficiently large to pass over the diameter of the appropriate sphere being measured. A ruler or tape measure is used to determine the width of the caliper opening and hence the diameter of the sphere. Measurement around several axes of the sphere can be made and then compared.
- The manufacturer of the prover, per the customer's request, generally can supply specified pre-manufactured sizing rings. Sizes of 2 – 5% over-size are typical, although any size ring can be manufactured, according to the requirements and dimensions of a specific prover. The sizing ring can then be passed over the sphere, around several axes; inflating or deflating the displacer as required to fit, in order to obtain the correct size. *If it is determined that the sphere size must be larger or smaller than the inside diameter of the sizing ring, the sizing ring should be labeled as not suitable for this prover and one of the other sizing methods should be used.*
- Stainless Steel or Plastic Covered Material measuring tapes, preferably $\frac{1}{4}$ in. in width, can go around the circumference of the sphere, along several axes, to obtain a measurement. Comparison around different axes should be made.

Regardless of the method used, all measurements shall be taken across at least two perpendicular diameters or circumferences. The smallest diameter or circumference measured is to be considered the real diameter or circumference of the sphere, so that, whatever percentage inflation is chosen, the sphere will have a minimum diameter or circumference of that amount.

An example of the calculation of the sphere over-sizing is as follows:

Prover Diameter	=	16 in.
Wall Thickness	=	0.375 in.
I.D. of Prover	=	$[16 - (2 \times 0.375)] = 15.25$ in.
Prover Circumference	=	$\pi \times d = 3.141593 \times 15.25 = 47.91$ in.
Sphere Oversize by 3%	=	$47.91'' \times 1.03 = 49.35''$ (approximately $49\text{-}\frac{3}{8}$ in.)

In the above example the sphere will require its circumference to measure $49\text{-}\frac{3}{8}$ in. after inflation, checked around two axes, to be at three percent over-size in the prover. The lowest axial measurement is taken as the size of the sphere. For example, if the equatorial axis measures $49\text{-}\frac{3}{8}$ in., and the polar axis measures $49\text{-}\frac{5}{8}$ in., then the size of the sphere is considered to be $49\text{-}\frac{3}{8}$ in. or three percent oversize.

Over-sizing the sphere during a calibration is done to prevent water leakage past the displacer during calibration passes. Additional over-sizing may be necessary to compensate for piping irregularities, such as ovality in the pipe, coating problems, and mandrel marks in the 90° bends and the 180° degree returns. However, an excessively over-sized displacer may result in sphere chatter and may cause leakage past the sphere or erratic detector switch activation. Undersized spheres may result in irregular detector switch action and/or leakage past the sphere.

If the prover is constructed with openings in the calibrated section, such as vents, drains, detector holes, or flange separations, etc., that are wider than the surface sealing width of the sphere, a momentary leak path can exist. For example, an 8 in. standard wall pipe prover with a $\frac{1}{2}$ in vent opening will require a prover sphere over-sized by approximately four percent to generate a sealing width sufficient to span the opening width by a comfortable margin, in this example 0.66 in.

Table 2 shows typical relationships between pipe sizes, sphere inflation and surface sealing widths. The purpose of this table is to show the minimum sealing width required to span openings in the measuring section. Sealing width for a different pipe wall thickness and sphere inflation may be calculated by reference to API MPMS Chapter 4 Section 2, Appendix F—Prover Sphere Sizing. Other criteria for sizing the sphere must also be considered.

The displacer shall have one last examination for condition, size and ovality, preferably with an observer (witness) present. Most new detector switches are designed with $\frac{3}{4}$ in. activation rods that pass through the pipe wall. The width of the seal provided by the sphere must be wide enough to cover the void in the pipe wall where mechanical detectors are installed. Before its final installation in the prover, it is suggested that the sphere be covered with a thin coating of a recommended water-resistant lubricant, so that when the displacer is operated at low flow rates during the waterdraw calibration, it will continue to move smoothly through the measuring section. Reinstall the displacer into the prover and close all openings. Record the type of material, durometer (if known), and the size of the displacer on the waterdraw calibration report.

Changes in fluid properties, operating conditions and equipment components may affect the uncertainty of the volume relative to the volume obtained at calibration conditions.

Table 2—Sphere Sealing Width Relationships

Pipe Nominal	Pipe ID	% Inflate	Sealing Width	% Inflate	Sealing Width	% Inflate	Sealing Width	% Inflate	Sealing Width	% Inflate	Sealing Width
6	6.065	2	0.25	2.5	0.31	3	0.37	4	0.50	5	0.64
8	7.981	2	0.33	2.5	0.41	3	0.49	4	0.66	5	0.84
10	10.02	2	0.41	2.5	0.51	3	0.62	4	0.83	5	1.05
12	12.00	2	0.49	3	0.74	4	1.00	5	1.26	6	1.53
14	13.25	2	0.54	3	0.82	4	1.10	5	1.39	6	1.69
16	15.25	2	0.62	3	0.94	4	1.27	5	1.60	6	1.94
18	17.25	2	0.70	3	1.07	4	1.44	5	1.81	6	2.20
20	19.25	2	0.79	3	1.19	4	1.60	5	2.02	6	2.45
22	21.25	2	0.87	3	1.31	4	1.77	5	2.23	6	2.71
24	23.25	2	0.95	3	1.44	4	1.94	5	2.44	6	2.96
26	25.25	3	1.56	4	2.10	5	2.65	6	3.22	7	3.79
28	27.25	3	1.68	4	2.27	5	2.86	6	3.47	7	4.09
30	29.25	3	1.81	4	2.43	5	3.07	6	3.72	7	4.39
36	35.00	3	2.16	4	2.91	5	3.68	6	4.46	7	5.25
42	41.00	3	2.53	4	3.41	5	4.31	6	5.22	7	6.15
48	47.00	3	2.91	4	3.91	5	4.94	6	5.99	7	7.05

Note 1: The inside pipe diameters used in the above table are for illustration only.

5.5 WATER FILLING, VENTING AND CIRCULATION OF PIPE PROVERS

Using a circulating pump start filling the prover with water, which is clean and free from entrained air. Move the sphere or piston through the prover, and vent off any air at all high point vent valves, allowing water to flow from the vents. Air pockets that remain in the prover provide areas that can be compressed during calibration runs. Air has the effect of causing the volume of water displaced to vary, and correspondingly inaccurate or changing prover volumes will result.

Continue passing the sphere or piston around the prover and circulating the water through the prover, until all air is expelled and the temperatures at the prover inlet and outlet are stabilized.

Operators should be aware that on a bi-directional prover, with launch chambers mounted at a 45-degree angle, the vents at the end of the launch chamber are usually lower than the top corners of the launching chambers. In this configuration, it is often extremely difficult to remove all the air without first loosening the top bolts of the blind flanges or releasing slightly the closure doors at the end of the launch chambers. This is usually the only way to vent any pockets of air remaining in the top corners of the launching chambers unless an appropriate vent has been installed to reach these top corners.

6.0 Preliminary and General Calibration Procedures

Changes in fluid properties, operating conditions and equipment components may affect the uncertainty of the volume relative to the volume obtained at calibration conditions.

6.1 GENERAL CALIBRATION DISCUSSION

The base volume of a unidirectional displacement prover is its one-way volume, determined by waterdraw calibration, that is displaced into field standard test measures as the displacer moves from one detector switch (A) to a second detector switch (B), always in the same direction.

The base volume of a bi-directional displacement prover is its round trip volume, determined by waterdraw calibration, that is displaced into field standard test measures as the displacer moves between two detector switches (A and B). A round trip volume consists of the displaced volume in one direction (A to B) plus the following displaced volume in the opposite direction (B to A).

The base volume of a tank prover is its “to deliver” volume, determined by waterdraw calibration, from a liquid level in the upper neck to a liquid level near or at the “zero” position in the lower neck. There are two waterdraw calibration methods or techniques for determining the base volume of a tank prover. Either water is drawn from a full tank prover into various field standard test measures (conventional Waterdraw Method), or water is drawn from various full field standard test measures into the pre-drained tank prover (Water-fill Method).

6.1.1 Calibration Records

All the involved parties (witnesses) should review the Calibration Certificate Package from the previous prover calibration together with all the past maintenance records and calibration history of the prover that is available. Confirm that the identifying numbers on all the calibrated equipment (test measures, thermometers, pressure gauges etc.) to be used in the calibration correspond to their respective reports of calibration. Verify that all the temperature-indicating devices (e.g., thermometers) and pressure-indicating devices (e.g., pressure-gauges) have up-to-date certificates of calibration.

All field standard test measures to be used to calibrate the prover must have up-to-date calibration certificates, which shall be verified. An up-to-date calibration certificate for a test measure is defined in the latest edition of the API *MPMS* Chapter 4.7, “Field Standard Test Measures.”

In a case where infrequently used test measures, as described in API *MPMS* Chapter 4.7, are requested to be used in the calibration, this request shall be made before the date of the calibration. All the interested parties shall together determine whether the test measures to be used meet the criteria established for infrequently used test measures. Their findings shall be conclusive and binding, and shall be delivered to the owner/operator of the prover to be calibrated, in writing, before the date of the calibration.

6.1.2 Temperature and Pressure Device Verification

A certified or calibrated thermometer shall be on-site with a certificate of calibration accuracy. The certificate of calibration shall be traceable to NIST or other appropriate national metrology institutes. The certified thermometer shall be used to verify the accuracy of all the other thermometers (working thermometers) used in the calibration procedures. The certified or calibrated thermometer and the working thermometers must agree within $\pm 0.1^{\circ}\text{F}$ ($\pm 0.05^{\circ}\text{C}$). Alternatively, working thermometers that have been certified to have been verified at three points (e.g., high, mid and low range points) within one year and a day of the time of the prover calibration by a thermometer that has a calibration traceable to NIST or other appropriate national metrology institutes may also be used providing that all of them agree among themselves within $\pm 0.1^{\circ}\text{F}$ ($\pm 0.05^{\circ}\text{C}$).

Electronic temperature measurement devices may be used in the calibration if there is agreement between all the represented parties. If using electronic temperature measurement devices then the requirements laid out in API *MPMS* Chapter 7, “Temperature Measurement”, shall be followed. As part of the requirement that the device be verified before each calibration, this verification shall be carried out against a calibrated or certified thermometer, accurate to $\pm 0.1^{\circ}\text{F}$ (0.05°C).

A thorough inspection of all the thermometers to be used shall be made, and care must be taken to observe any signs of mercury separation, or any other defects. Once a set of thermometers has been chosen, an on-site verification of them shall be made to determine that all their readings agree to within 0.1°F (0.05°C) of the calibrated or certified thermometer. This shall be done in a temperature stable water bath that is at the approximate temperature of the water to be used in the calibration of the prover. Any thermometers that are outside of this tolerance shall be rejected as defective. If any electronic thermometric devices are used then all the same requirements as the glass thermometers shall apply. All temperature measuring devices shall be read and recorded to the nearest 0.1°F (0.05°C).

A calibrated dial type pressure gauge, or other acceptable type of pressure device (e.g. digital pressure gauge, pressure transmitter, etc.), accurate to within 1 psi, shall be used for the waterdraw calibration providing that it has a valid certificate of calibration available on-site, which is traceable to NIST or other appropriate national metrology institutes. The definition of a valid certificate of calibration can be found in paragraph 6.7, “Temperature and Pressure Indicators”. If using an analog, dial type, pressure gauge, then before beginning the waterdraw calibration it shall be checked to see that it reads “zero” at atmospheric pressure. If a valid calibration certificate is not available for this pressure gauge, or the “zero” setting requires adjustment then a recalibration of the gauge will be required. Alternatively, another satisfactory pressure gauge shall be obtained that has with it a valid certificate of calibration. If an electronic pressure transmitting and/or digital pressure-indicating device is being used, it shall have a valid certificate of calibration accuracy and be checked for “zero” at atmospheric pressure. If a valid certificate of calibration is not available, or any adjustments to the electronics (e.g. zero, span, gain, range, etc.) have to be made, then a recalibration of the device shall be required. Alternatively, another satisfactory pressure device shall be obtained that has with it a valid certificate of calibration. All pressure measuring devices shall be read and recorded to the nearest one pound per square in. (1 psig).

A selected location performing any of the above temperature or pressure calibrations shall provide all the necessary equipment to carry out these calibrations, including all certificates of calibration accuracy for the equipment and instrumentation used, with full traceability to NIST or other appropriate national metrology institutes.

6.1.3 Temperature Readings

Temperature stability is extremely important in all prover calibrations. Although not always achievable, the intent during any given calibration pass is to keep the test measure water temperatures within 2°F (1°C) of the starting water temperature in the prover.

Water temperature stability and accuracy in bi-directional provers can be compromised by not properly displacing the bulk of the water from calibration pass to calibration pass. If the displacer is moved only a short distance past the second detector switch, and then the direction of the flowing stream is reversed using the four-way valve, the indicated temperature of the prover might not be truly representative of the actual prover temperature. Allowing the displacer to travel all or most of the way to the launching chamber at the end of each pass can enhance temperature stability and accuracy.

Reading errors are a chief source of temperature error. It is essential that all glass stem thermometer readings be taken with the eyes perpendicular to the stem and at the same level as the thermometer medium. Therefore, the thermowell location should be placed in a position where accurate readings can be taken in a comfortable manner. The preferred location for the thermowell would usually be four or five feet above ground level. All temperatures shall be read and recorded to the nearest 0.1°F (0.05°C).

It is recommended that at least two thermometers be used in all calibration passes, as this will expedite taking the prover temperature together with the required test measure temperatures. Careful thought shall be given to the location and installation of the prover thermowell, which is required for the determination of the downstream prover temperature. This temperature shall be taken at a location between the prover outlet detector switch and the inlet to the test measure for each calibration pass, but as close to the prover as practical. This usually means inserting a thermowell between the prover outlet pipe and its first hose connection. In the case of a bi-directional prover where an external four-way valve is used, it is usually necessary to install two thermowells. One thermowell is then used for the downstream temperature of the FORWARD passes, and the other thermowell is used for the downstream temperature of the REVERSE passes. It is extremely important that each thermowell be located in the flowing water stream and in the middle third of the pipe. The pipe diameter shall be small enough to allow the accurate placement of the thermowell. The thermowell probe shall be deep enough to enable the correct immersion of a glass thermometer stem or an electronic thermometer probe. Each thermowell shall also be filled with a suitable heat-conducting medium.

If using electronic temperature measurement devices then the requirements laid out in API *MPMS* Chapter 7, “Temperature Measurement”, shall be followed. As part of the requirement that the device be verified before each calibration, this verification shall be carried out against a calibrated or certified thermometer, accurate to $\pm 0.1^\circ\text{F}$ (0.05°C).

Temperature stability of the water is the key to a successful calibration. The water used for a waterdraw calibration should have a temperature that lies somewhere between 40°F and 100°F (4 °C and 38 °C), and if possible these limits should be observed. However, water with temperatures outside this range has been used in successful calibrations.

Water temperatures of bottom draining type field standard test measures are usually taken by immersing a fast acting thermometer into the discharging stream, while draining, for a period long enough to stabilize the temperature. The thermometer should have its temperature-sensing bulb contained in a cup case (usually a wood back type), so that its stem is always totally immersed in the discharging stream. The cup case and thermometer shall be held in the stream of water long enough to stabilize during the first third of the discharge from the test measure. When the cup case is lifted out of the stream for reading purposes, the reading should be made quickly to avoid any temperature changes. Steps should be taken to handle only the upper part of the cup case assembly. Holding the reservoir part of the cup case can change the temperature reading. In the case where a portable electronic thermometer (PET) is being used to measure the water discharge temperature, the probe shall be contained in a wood back cup case as with the glass thermometer. This will minimize the effects of ambient temperature on the reading due to voids in the flowing stream. The temperature shall be read with the probe and cup case immersed in the discharging stream and shall not be removed for reading as though it were a glass thermometer.

Temperatures can also be taken by immersion of the thermometer into the main body of water inside the test measure, and agitating the thermometer for an appropriate time to stabilize, withdraw and read. In this case, the temperature reading must be taken after reading the liquid level of the test measure. Exceptions would be:

- Using the test measure to calibrate an atmospheric tank prover by water “filling” the prover
- After filling the test measure prior to transferring the water into a larger test measure for pre-filling

If thermowells are installed within test measures then they may be used to measure water temperatures.

For each pass, displacement provers shall have a water temperature taken at the prover outlet during the displacement of the first third of the water volume. This usually means waiting until the temperature stabilizes, once flow is established into the test measure, since the thermowell is subject to ambient temperature effects between calibration passes (e.g., stopping for a short time, reversing flow, etc.). No temperatures shall be taken while the circulating flow is stopped or when the flow is not filling a test measure. Prover temperatures shall be taken on the downstream side of the displacer and as close as possible to the second detector. This thermowell location will alternate from side to side on bi-directional provers for the “forward” and “back” passes making up a round trip run unless a single thermowell is installed at a common discharge point.

When calibrating a tank prover, the temperature is normally taken when the prover is full of water. This temperature can be taken by immersion of the temperature device into the body of the vessel or by reading thermometers mounted directly into thermowells in the tank prover. The water temperature can also be taken by means of a thermowell installed immediately downstream of the discharge valve. In this case the temperature of the discharging stream of water shall be read at the beginning of the discharge, immediately following the reading of the liquid level on the upper scale, and shall be taken before one-third of the volume has been discharged from the tank prover.

6.1.4 Pressure Readings

Using the calibrated pressure indicator, record the pressure of the water in the prover. This pressure shall be determined at the beginning of the calibration pass when the water is flowing through the solenoid valve line to drain. Pressure on a displacement prover is taken downstream of the second detector for a given pass, while the displacer is approaching the first detector for that same pass and the water is being discharged at a very slow rate through the solenoid valve line back to the reservoir. During the calibration, a minimum back pressure of five psig shall be maintained at the waterdraw calibration unit to ensure the complete packing of all the lines during each calibration pass. All pressures shall be read and recorded to the nearest one pound per square inch (1-psig).

6.1.5 Waterdraw Calibration Unit

When planning waterdraw calibrations, it is critical that the size, volume, and physical location of provers be of prime consideration in determining the optimum waterdraw equipment. Undersized equipment results directly in slower work performance, longer work days and increased meter prover downtime. Proper planning makes for an efficient operation.

A waterdraw calibration unit is generally portable and consists of a water reservoir, a low-pressure centrifugal pump, associated pipe work, hoses and a four-way valve. Pump(s) shall be adequate in size and volume to launch sphere-type displacers from the prover's launch chambers back into the calibrated section. Included on the waterdraw unit is a solenoid valve assembly, a control panel with detector switch indicator assembly, and a range of field standard test measures with a valve manifold for filling. The test measures are normally positioned so that they can be drained directly back into the reservoir. Single or multiple solenoid-valves may be used, and depending upon the piping configuration selected, two-way or three-way type solenoid valves may be used as required. The centrifugal pump circulates water from the reservoir through the prover. The water is then returned either into the field standard test measures and/or back into the reservoir. The calibrated test measures may each be filled and drained once, or many times during a calibration run, depending upon the volume of the prover. To reduce the uncertainty caused by test measure scale reading errors, the number of test measures filled during a calibration pass shall be kept to the minimum possible, based upon the volume of the prover and the number and sizes of the test measures available.

The waterdraw unit should be located as close as possible to the prover to be calibrated, within logistical constraints and safety considerations, in order to keep the hose connections as short as possible. This will greatly help to minimize any possible temperature variations, any excessive pressure differentials, and will also assist in keeping to a minimum the volume of water contained between the second detector switch and the inlet to the test measures. If this water inventory is large then a small change in the temperature of this water volume from the beginning to the end of each calibration pass will have a significant effect on the resulting prover volumes. See Appendix B for a full discussion of this effect.

6.1.6 Field Standard Test Measures

6.1.6.1 General Description

A field standard test measure is a vessel fabricated to meet API *MPMS* Chapter 4.7 criteria and calibrated by the National Institutes of Technology (NIST) or other national metrology institute. Its primary purpose is to provide a standardized volume, used for the calibration of displacement and tank provers, when calibrated by the waterdraw method. Specifications for test measures

shall be in accordance with the latest edition of the API *MPMS* Chapter 4, Section 7, “Field Standard Test Measures.” In addition the latest edition of the National Institute of Standards and Technology, Handbook 105, Section 3, *Specifications and Tolerances for Graduated Neck-Type Field Standards* may also be consulted for specifications.

Test measures are constructed of stainless steel ranging in sizes from one gallon to 1,500 gallons. In practice, the 500-gallon is the largest size test measure in regular commercial use, while the 100-gallon and 50-gallon are the test measure sizes used commonly. Test measures may be built in any convenient size, or in particular sizes, according to specific requirements and distinct prover volume sizes. Only test measures calibrated “to deliver” shall be used in the calibration of meter provers. Most test measures are filled through the top but that does not exclude the use of bottom filling test measures, provided that precautions are taken to detect any leakage through a closed bottom filling valve. A bottom filling arrangement for test measures is shown in Figure 5. Detailed descriptions of the utilization of field standard test measures can be found in Appendix D.

6.1.6.2 Calibration

Field standard test measures provide a primary link in the traceability chain to the National Institute for Standards and Technology (NIST). A Report of Calibration provided by NIST for each test measure shall be supplied to its owner, together with a copy of all the data obtained and used during the calibration and calculation procedures. The actual “to deliver” (some Reports of Calibration include both the “to contain” and the “to deliver” volumes) capacity of the test measure as shown on the Report of Calibration, shall be used as the official base volume of the test measure rather than the nominal volume. The NIST test measure seal numbers, cubical coefficient of thermal expansion, base temperature, method of calibration (gravimetric or volumetric) and the percentage volume uncertainty of each test measure used, are also stated on the Report of Calibration. Each field standard test measure shall have a current calibration certificate as defined in the latest edition of API *MPMS* Chapter 4.7, “Field Standard Test Measures” (e.g., within the last three (3) years per API *MPMS* Chapter 4.7, 2nd Edition, December 1998).

Each time a test measure is used it should be inspected for any signs of physical damage (e.g. dents, broken NIST seals, etc.) that may compromise its calibration integrity. Test measures shall be rejected any time there is significant evidence of damage, distortion, repairs, alterations or maintenance to the test measure that could affect its volume, unless verification of the previous volume, or a new re-calibrated volume, is provided.

6.1.6.3 Scale Readings

The water level on the scale of a field standard test measure is read with the eyes in a horizontal plane level with the bottom of the meniscus in the sight glass. Scale readings may occur anywhere above or below the zero mark. After the liquid level is read, the base measure volume (BMV) is then adjusted mathematically using a plus or minus liquid level (volume) scale reading.

The scale of a normal sensitivity test measure is read to a discrimination that is in a range from 0.2 in.³ to 5 in.³. The scale of a high sensitivity test measure is read to a discrimination that is within a range from 0.1 in.³ to 1.0 in.³. The maximum discrimination in any case would be to 0.1 cubic inches, and the minimum discrimination would be to $\frac{1}{2}$ a scale division. See Table D–2 in Appendix D for further guidance. Various techniques may be used to determine the water volume (scale reading) in a field standard test measure. Any of the following methods can be used; however, Method 3 is the normal operating practice used today.

- Method 1: Fill each test measure to its exact certified (zero) capacity, and allow the final water level to be read on completion in the last test measure filled.
- Method 2: Slightly overfill each test measure and then bring the level back to the exact capacity (zero) by withdrawing some of the liquid. The liquid that is withdrawn is then released into the next test measure to be filled.
- Method 3: With graduated neck test measures it is not necessary to operate at the zero level. Therefore, the test measure may be filled to any location on its scale, the liquid level read, and its certified capacity is then adjusted mathematically using a plus or minus scale reading (\pm SR). A minus signifies that the water level is below the certified capacity (zero mark) on the test measure scale, and a plus indicates that the water level is above the zero mark on the scale.

6.1.6.4 Draining

Field standard test measures are calibrated with water and they are usually calibrated wet, “to deliver”, so that they may be used in a continuous manner without drying each time. Following the exact drain down procedure as specified by the calibrating agency is an essential part of the definition of the “to deliver” volume on the Report of Calibration. The words “cessation of the main

flow” describe a single dramatic event that occurs abruptly and can easily be determined. No distinction is made between a trickle and a fast drip, however, the change over usually occurs from the full discharging water flow to a trickle, almost instantly, and is very easy to recognize.

Test measures with a solid bottom arrangement, normally ten gallons or less, are emptied, by inverting the measure to a specified angle (e.g., 70 degrees). At the cessation of the main flow, the draining is continued for a specified time (e.g., ten seconds), and the test measure is then returned to an upright position, ready for use. The drain time and inversion angle specified on the Report of Calibration, for each test measure in use, shall always be followed.

Larger test measures, normally ten gallons or more, have a conical bottom, a center drain line and a bottom drain valve. Opening the drain valve, and allowing the water to drain until the cessation of the main flow, empties the test measures. Draining is then continued for an additional specified time (e.g., 30 seconds). The drain time specified on the Report of Calibration, for each test measure in use, shall always be followed.

6.1.6.5 Test Measure Selection

Prior to the calibration of the prover it is necessary to ascertain the sizes and numbers of the test measures available on the water draw calibration unit and the filling and rotation sequence that can best be used for these available test measures. These requirements can be determined from the known or estimated volume of the prover together with the filling and draining times of the test measures. In the case of a new or modified prover, it is sometimes beneficial to make an unofficial pass to determine the approximate volume of the prover and to establish a convenient filling order for the available test measures.

From all the test measures available for the calibration, several shall be chosen to best accommodate the displaced volume, and which will allow for filling and draining while maintaining continuous flow where possible, with a minimum number of test measure fillings.

Once the test measures have been selected for use, their filling order, including the size of the last test measure to be filled is immaterial, and has no influence on the overall uncertainty of the volume for any given pass. However, the size of the neck volume of the ending test measure should exceed the allowed tolerance for a given pass. The filling order does need to be addressed however, in order to maintain a smooth filling operation, without significantly surging the flow rate, or causing the displacer to stop and start too often. In order to reach the specified flow rate as quickly as possible, waterdraw passes typically commence in the medium or larger sized test measures. After the first pass has been completed, the filling sequence can be reviewed for continuity and smoothness. It is considered practical to keep the test measure filling order in the same sequence on subsequent passes. However, if desired, changes to the filling order from one pass to the next can be made. This situation can occur when the observation data that is gathered from the first pass suggests a change in the filling order.

6.1.6.6 Leveling

When the liquid level of a field standard test measure is read through the sight glass adjacent to the scale, the test measure itself shall be level and full of water.

The NIST Report of Calibration of a field standard test measure, shall provide the criteria for determining the level state of any given test measure when filled with water. In case of any disagreement between the permanently mounted spirit levels and the use of a precision machinist’s spirit level across the top of the neck, the NIST Report of Calibration definition of the level position for that test measure shall apply.

6.1.6.7 Using Field Standard Test Measures for Waterdraw Calibrations

All field standard test measures being used in the calibration shall be visually inspected internally and externally before use to ascertain that their capacities have not been altered by dents, internal corrosion or surface deposits. In addition inspect each test measure carefully to make sure it is free of rust, broken seals, broken gauge glasses and scales, broken or missing levels, leaks or defective drain valves. Only test measures calibrated with a “to deliver” volume shall be used in the calibration of meter provers. All test measures to be used shall be clean on the inside so that contamination does not compromise their calibrated volume, or cause a change in their drain down characteristics.

During preparation, all the test measures to be used in the calibration must be “wetted”, that is they shall have their entire inside surfaces coated with water and then be drained. “Wetting” of the test measures means that they shall be totally filled with water. Once filled, ensure that the test measures are level in two axes of a horizontal plane. The level of the test measure should be veri-

fied each time that its liquid level is read. Drain all of the test measures in the same manner in which they were calibrated. That is, the draining times as prescribed on the Report of Calibration for each test measure. The prescribed drain time is that additional time to continue draining after the cessation of the main flow.

Typical prescribed draining times of NIST calibrated test measures, according to the present edition of API *MPMS* Chapter 4.7, are as follows:

- For invertible-type test measures —10 seconds.
- For bottom drain valve type test measures—30 seconds.

The prescribed drain time of test measures must be adhered to each time they are emptied in order to replicate the “to deliver” of its calibrated volume. It follows that they should not sit empty for extended periods of time because of evaporation. Cans that have been “wetted” before beginning a calibration pass should be re-filled within a reasonable amount of time since they were last drained in order to minimize evaporation effects. If there are delays in starting, then the test measure(s) shall be re-filled and then re-emptied in the prescribed manner.

The liquid level of a field standard test measure is read with the eyes in a horizontal plane that is perpendicular to the bottom of the meniscus of the water in the sight glass. Visual aids that aid in determining the exact intersection of the bottom of the water meniscus with the horizontal plane perpendicular to the sight glass gauge scale are sometimes helpful. This reading should take place as soon as possible after filling, but after all the air bubbles caused by agitation are dispersed from the sight glass.

6.1.6.8 Normal Test Measure Operations

Setting up test measures for calibration use in the field normally involves the following preparatory steps. Inspect all test measures to be used in the calibration for cleanliness, dents, unbroken sight glasses, scales and seals. After this inspection, all the test measures shall be leveled while they are in water-filled condition. After filling and leveling of the test measures, check for leaks in the entire system. Drain the test measure as specified on the Reports of Calibration. The test measures are now ready for calibration use.

During a normal calibration run, the test measure is filled with water to a scale reading in the sight glass. After closing off the test measure, allow the water to settle and verify that the measure is still level. Read the water level at the bottom of the meniscus and record this scale reading as a (+) or (–) neck volume, depending upon whether the reading is above (+) or below (–) the zero line on the scale. The temperature of the water in the test measure is then determined before draining or while the test measure is drained in the prescribed manner. The test measure is now ready for the next filling if required.

All scale readings and temperatures obtained during the calibration run/pass are recorded on a field data sheet for subsequent calculations.

6.1.6.9 Variations from Normal Test Measure Operations

Occasionally in field use, due to abnormal conditions test measures may need to be operated in a different manner from normal usage. Generally these conditions are identified as either requiring that a test measure be overfilled, under-filled, or possibly a combination of both, during a particular calibration run cycle. If any of these conditions should arise during a prover waterdraw calibration, the techniques described below can be used to help remedy the deficiency. See Appendix D for complete details.

6.1.6.9.1 Test Measure Pre-Fill Operation

Sometimes during a waterdraw calibration it is necessary to accurately determine the volume of a partially filled test measure. This determination can be made by a method known as pre-filling. Pre-filling is accomplished by first transferring water from a pre-filled smaller test measure into a larger test measure. The object is to bring the water drawn from the prover into the larger test measure up to a level that can be read on the gauge scale glass.

6.1.6.9.2 Test Measure Neck Draw Operation

Sometimes during a waterdraw calibration it is necessary to accurately determine a volume of water in excess of the capacity of the last test measure. This determination can be made by a method known as neck draw. First, lower the water level in the neck of the test measure to a lower level on the scale, and then re-fill the neck again to a higher level. It is possible that this procedure may have to be repeated several times in extreme cases to accommodate the excess water.

6.1.6.9.3 Combination Pre-Fill and Neck Draw Operations

It is also possible to have a situation where a test measure pre-fill and a test measure neck draw are both necessary during the same prover calibration run. Although this is not common, it is a situation of which operators should be aware.

6.1.7 Displacers

In displacement provers, displacers are used to form a seal between the upstream and downstream water volume. This displacer is moved by the water flow and pushed through the measuring section, where it actuates the detector switches that are used to define the volume of the prover. The most common type of displacer is the inflatable sphere.

Before the waterdraw calibration of the prover is started, the sphere displacer shall have been examined for condition and size. Once properly sized and coated with a thin film of a water-resistant lubricant, the sphere was installed in the launching chamber of the prover ready for the calibration. The purpose of the lubricant is to ensure that, while the sphere is operating at lower than normal flow rates during the waterdraw calibration, it will continue to move smoothly through the measuring section. A sphere moving with a shuddering or jumping motion during a pass/run can significantly impact the calibration results obtained.

Jumping, irregular, or shuddering motion of the sphere during a pass can usually be detected by fluctuating pressures on the pressure gauge, or by observing changing flow rates when all the water is passing through the solenoid valve and the sphere is approaching the detector switch. Possible causes of this erratic or irregular movement of the sphere are:

- Over-inflation of the sphere
- Under-inflation of the sphere
- Lower flow rates
- Lack of lubricant on the sphere

Trace hydrocarbons remaining on the interior walls of the prover pipe can be a cause of the failure of the sphere lubricant coating to ensure its smooth motion. In this situation of erratic sphere motion it may be necessary to stop the calibration and remove the sphere from the prover. Inflate or deflate the sphere as necessary, re-coat it with lubricant and then re-install in the prover. Repeat all the necessary procedures to restart the calibration.

Repeatability problems during calibration runs often require all aspects of sphere condition and inflation to be examined, up to and including its removal from the prover for inspection and correction.

Any changes to sphere conditions that affect the seal of the sphere or the actuation of the detector switches may alter the effective volume of the prover.

6.1.8 Water Quality

Water quality is very important in all waterdraw calibrations. It does not have to be pure distilled water as ordinary drinking water is excellent for calibration purposes. Dirty water, heavily aerated water, hydrocarbon contaminated water, salt water, or any water of inferior quality, can severely affect the capillary action of the meniscus, the surface tension action in the sight glass, the draining action of the test measure, or the amount of clingage retained by the test measures. All of these effects and others attributable to inferior quality water can have a detrimental effect on any successful prover calibration.

6.1.9 Air

Air must be vented from all high points in the system before beginning the calibration. This includes those high points, which are static during the calibration and which, because of varying pressures and the friction load on the displacer, can result in erratic displacements of water into the test measures. Passing the displacer around the prover with all the high point vents open to allow a trickle of water is a common method of ensuring that all air is removed from the system. The waterdraw concept of calibration depends upon a true hydraulic displacement, which is only possible in an air-free system.

6.1.10 Hydrocarbons

All hydrocarbons should have been removed from the system during the cleaning process. Any still present must be removed from the prover, and not be allowed to contaminate the test measures, before beginning the calibration. Even in static locations hydrocarbons adversely affect the quality of the water, change the expansion/contraction characteristics of the water in the system with temperature and pressure changes, and usually introduce gas into the system on a continuing basis.

6.1.11 Hoses, Pumps and Connections

The packing gland or mechanical seal in the circulating water pump, and all the inlet piping, shall be inspected for suction leaks. Suction leaks are especially problematic in allowing air to enter into the system.

If flexible hoses are being used they should be free of kinks, buckles and leaks. All the hoses should be of a non-collapsible type for reduced pressures and must have the same shape at the beginning and end of any calibration run. Rigid hoses are best for this purpose.

All the flexible hose connectors should have gaskets in good condition, unbroken locking arms or connectors, and all hose connections shall be leak free.

6.1.12 Flow Rates during Calibration of Displacement Provers

Calibration flow rates should be chosen so that the displacer will have a steady continuous movement throughout the calibration pass, while filling and emptying the test measures. During all calibration passes it is desirable to keep the displacer moving smoothly at a constant flow rate as much as possible. If the flow must be stopped at any time (e.g., waiting to drain a test measure), the displacer should be stopped and restarted, in a horizontal plane, both smoothly and relatively quickly. Stopping the sphere in a bend or any place where the pipe is welded is not recommended. Logically, if there is no leakage past the sphere, it should make no difference whether or not it is halted during a calibration pass within the limitations stated above.

The minimum flow rate is experienced when the water flow is passing only through the solenoid valve. If the displacer shudders or moves erratically at this time, it may be a sign:

- That the displacer is not lubricated sufficiently
- That the solenoid valve opening is too small
- That there are hydrocarbons in the system
- That there is air in the system
- That the water pressure is improperly changing

The calibration shall be carried out at flow rates such that the test measures can be filled without surging, overflowing or splashing water out of the top. Any splashing, overflowing or other loss of water from these test measures will render the calibration pass invalid.

For leak detection and reproducibility purposes, the flow rate on displacement provers shall be changed between consecutive calibration runs by 25% or more (e.g., fast/slow/fast or slow/fast/slow):

- On unidirectional provers, the flow rate between consecutive calibration passes shall be changed by 25% or more.
- On bi-directional provers, the flow rate between consecutive calibration round trips shall be changed by 25% or more with the “out” (traveling away from home position) pass and “back” (returning to home position) pass for any given round trip always being at the same flow rate. The terms “left to right” and “right to left” are often used to describe the passes in two different directions. By convention, “left to right” and “right to left” are viewed from the end of the prover where the launching chambers and four-way valve are located. See Chapter 4, Section 9, Part 1, “Introduction to the Determination of the Volume of Displacement and Tank Provers,” Figure 1, “Bi-directional Prover Orientation of Left and Right”.

However, at the discretion and concurrence of the operators and represented parties, the specified order in which the calibration flow rates are changed may be altered (e.g., fast/fast/slow, fast/slow/slow, slow/fast/fast or slow/slow/fast). In any case, the flow rate for at least one of the runs on unidirectional provers shall be at a rate that represents a change of 25% or more from the other runs. On bi-directional provers, at least one of the passes in the “out” direction and at least one of the passes in the “back” direction shall be at a rate that represents a change of 25% or more from the other passes in their respective directions.

The flow rate can be determined by one of three methods:

- Using a flow meter to monitor the flow rate while adjusting the filling valve(s)
- Timing the filling of the largest test measure being used.
- Timing the entire calibration pass [(total volume / time) = flow rate].

Regardless of the method used, a change of 25% or more to the flow rate applies to the entire calibration pass and not to just a portion of the pass. Consider the calibration of a 200-gallon prover with two 100 gallon test measures, in which a “fast” run was conducted by filling each test measure at a rate of 60 GPM. A 25% reduction in flow rate could be accomplished by filling each test

measure at 45 GPM which would be appropriate. However, an inappropriate approach would be to fill one of the test measures at 60 GPM and the other test measure at 30 GPM. Even though this would result in a calculated overall flow rate of 45 GPM, or a reduction of 25%, the criteria of applying the rate change to the entire calibration pass would not be met. If test measures of various sizes are used, it is understood that filling rates would vary between them. In that case, rate changes made would be relative to each measure being filled.

6.1.13 Number, Continuity and Sequence of Calibration Runs

At least three consecutive calibration runs, that meet all the repeatability criteria, are required for the successful calibration of displacement provers.

Two consecutive calibration runs, that meet all the repeatability criteria, are required for a successful tank prover calibration. However, if the calibration scale is moved, then a third calibration run is required.

If any single calibration run does not meet the repeatability criteria, the reason must be ascertained, remedied, and the calibration continued until the repeatability criteria of an unbroken chain of three consecutive calibration runs is achieved.

- A calibration run on a unidirectional prover is a one way pass.
- A calibration run on a bi-directional prover is a round trip.
- A calibration run on a tank prover is one filling or emptying.

Any measured pass is part of the consecutive chain. However, in the case of mishaps, such as, the overflowing of a test measure, forgetting to close a drain valve, opening the wrong valve, missing a temperature, etc., the displacer may be returned to its previous starting position and that particular pass started over.

Re-starting a pass can only be done in a stable temperature condition. Therefore, it may be necessary to return the displacer to the launching chamber before beginning the repeated pass. When a single pass breaks the consecutive chain, either that pass, or the next, may be used to start the next consecutive chain.

Consecutive passes are defined as sequential measured passes. Due to constraints of time, weather, or other external factors, it is sometimes necessary to suspend the waterdraw calibration between passes. To restart the calibration process the following procedures may be required depending upon the length of time the calibration is suspended:

- The displacer shall be flexed by conducting at least one unmeasured pass.
- Care must be taken to ensure that flowing conditions and temperature are stabilized.
- All test measures shall be refilled, leveled and drained per requirements.
- All vents shall be checked for air and the system rechecked for leaks.
- The flow rate required for the calibration shall continue in the established sequence.

In the case of a sudden shutdown of the system during a calibration pass (e.g., pump failure, electrical failure, etc.), the test measure filling-valve shall immediately be closed so that air is not pulled into the system. If flow can be restored within a very short period of time (e.g., re-setting an electrical breaker etc.) then the pass can be continued. However, should a longer period of time be required to restore the system (e.g., replacement of the pump, restoration of the electrical power, etc.), then the procedure for a mishap to the pass, or the procedure for the suspension of a calibration, shall be followed. However, if the delay will be protracted, then the calibration shall be abandoned and restarted when the system has been fully restored.

If a displacement prover has multiple volumes, each volume shall be considered to be a stand-alone and independent prover volume. Each of these prover volumes shall be calibrated by a separate and independent waterdraw calibration. Each calibration shall meet the same criteria as described above. Reference Figure 2 in API *MPMS* Chapter 4, Section 9, Part 1, Introduction, for various detector switch configurations on multiple volume provers.

6.1.14 Calculations and Repeatability

Detailed calculation procedures are not included in this standard. For the complete details of the waterdraw method calculations, applicable to this standard, refer to the latest edition of the API *MPMS*, Chapter 12, Section 2, Part 4, "Calculation of Base Prover Volumes by the Waterdraw Method."

The Calibrated Prover Volume (CPV) of a unidirectional prover is the corrected volume displaced in passing the displacer from one detector switch to a second detector switch, always in the same direction. The described one-way procedure should be repeated until satisfactory repeatability of at least three calibration pass/runs is achieved. The average value of three or more con-

secutive one-way corrected volumes is considered the Base Prover Volume (BPV). The corrected volumes for all three or more consecutive calibration runs shall agree within a range of 0.020%.

The Calibrated Prover Volume (CPV) of a bi-directional prover is the corrected volume displaced in passing the displacer from the first detector switch (Detector Switch “A”) to the second detector switch (Detector Switch “B”), followed by the corrected volume displaced in passing the displacer from Detector Switch “B” back to Detector Switch “A”. These two consecutive single passes, in opposite directions, constitute a single round trip volume. The average value of three or more consecutive round-trip corrected volumes is considered to be the Base Prover Volume (BPV). The corrected volumes of three or more consecutive round trip runs shall agree within a range of 0.020%; the corrected volumes of three or more consecutive passes in the “out” direction, making up those round trips, shall agree within a range of 0.020%; and the corrected volumes of three or more consecutive passes in the “back” direction, making up those round trips, shall also agree within a range of 0.020%.

The Calibrated Prover Volume (CPV) of an atmospheric tank prover is the corrected volume measured between an upper liquid level and the lower level. The calibration shall be repeated until two or more consecutive volumes, after corrections, agree within a range of 0.020%. The average of the consecutive tank prover volumes shall be used as the initial calibrated volume of the tank prover, which is the volume between the upper reference level and the lower level. The upper neck scale and/or the lower neck scale should then be aligned so that the calibrated volume of the tank prover at the reference level aligns with the scale reading for that volume. Some tank provers have an upper scale that reads in + or – increments from a zero mark (similar to field standard test measures). Following the adjustment of the upper neck scale and/or lower neck scale, a final calibration run is made to verify that the scale adjustment is correct within 0.010% of the target volume (e.g., 500 gallons, 1000 gallons, etc.). In that case, the Base Prover Volume (BPV) is considered to be equal to the target volume. In the case where no adjustments are made to either scale, the average value of three or more consecutive corrected volumes is considered to be the Base Prover Volume (BPV). The corrected volumes for three or more consecutive calibration runs shall agree within a range of 0.020%.

Repeatability between the results of consecutive prover volumes (passes and runs) at standard conditions is calculated from the formula:

$$R = \left[\frac{(MaxCPV - MinCPV)}{(MinCPV)} \right] \times 100$$

For additional information refer to the API *MPMS*, Chapter 12, Section 2, Part 4, “Calculation of Base Prover Volumes by the Waterdraw Method”, for complete details on the determination of repeatability.

6.1.15 Calibration Certificate Package

All observation data shall be hand written in ink/ or collected, recorded, and reported automatically by a flow computer with audit trail capability. All the observation data shall be proof read against the input calculation data before signing the documents. In case of discrepancies or errors discovered at a later date the hand written observation data shall be used to correct the final volume. See Appendix C for examples of waterdraw calibration data sheets.

The calibration certificate package shall include the Calibration Report with the Date of the Prover Calibration prominently displayed on the front of the Calibration Certificate Package. Other items applicable to the calibration shall also be recorded in the Calibration Certificate Package as follows:

- the field standard test measures used
- the temperature indicators and pressure indicator used
- the location of the prover
- the owner or operator of the prover
- the serial number of the prover
- the material of construction of the prover
- the inside diameter of the prover
- the wall thickness of the prover
- the displacer type, durometer (if available), and the size
- the type of prover
- in the case of multi-volume displacement provers
 - a clear identification of the detectors used for this calibration

- the physical location of each detector
- A copy of the final calculation and summary documentation
- A copy of the handwritten observation documentation (signed by all parties as witness to the original observation data)
- Copies of the NIST Reports of Calibration for all of the field standard test measures used
- Calibration Certificates for all the temperature and pressure indicators used

6.2 DISPLACEMENT TYPE UNIDIRECTIONAL PROVERS WITH FREE DISPLACERS

A unidirectional prover with a free displacer operates with some type of sphere handling interchange. If this interchange is left in place during the waterdraw calibration, then it is normally used to launch the sphere for each calibration pass/run. At the end of its pass/run the sphere is allowed to continue into the interchange to await its next launching.

Before beginning a calibration on any unidirectional displacement prover with a free displacer, the air must be vented at all high points. This includes those points, which are static during the calibration. All venting shall be done before, during, and after moving the sphere through the prover several times, by leaving the vents partially open and continuously bleeding off air and water.

Unidirectional provers with sphere interchanges require special attention in that all the air must be vented with the interchange in both the open and sealed positions. This shall be done before, during, and after moving the sphere through the prover several times, by leaving the vents partially open and continuously bleeding off air and water.

With the interchange in place and functioning, the calibration can be performed using the normal operation to launch and receive the sphere displacer. To improve air elimination and temperature stability the sphere should be allowed to complete its forward travel at the end of a calibration pass, and be sent through the interchange for a re-launch from the launching chamber.

A four-way valve is usually located between the prover and the waterdraw unit for sphere positioning purposes at the first detector switch. All measured calibration pass/runs shall be made in the same direction as in normal prover operation. A trial run is sometimes made to work out any operational details and verify the approximate prover volume (especially on new provers).

Sometimes, the interchange is removed for the period of the calibration and replaced with a blind flange equipped with a connection to serve as the prover water inlet. In that case the sphere has to be placed into the prover pipe prior to the fitting of the blind flange. At the end of each pass/run, a four-way valve, located on or near the waterdraw unit, is used to return the sphere back to its starting position. On other occasions the sphere interchange may be removed or blinded-off from the remainder of the prover, and the sphere traversed inside the pipe between the prover detector switches. When the calibration is performed in this way the sphere is kept in the pipe section of the prover at all times and special care must be exercised to ensure the complete evacuation of air. After the displacer has been launched and completed its calibration run, a four-way valve is required to return the sphere displacer back to its starting position upstream of the first detector. Therefore, when using a four-way valve to return the sphere to the starting detector, the return pass is not measured. It is essential that all calibration runs be conducted in the same direction that the displacer normally travels.

Regardless of whether an interchange is being used or not, a four-way valve is required to position the sphere at the starting detector. See Figure 1.

On the first pass the following starting sequence is followed to position the sphere into its starting position under the first detector switch. The detector switches are named "A" and "B".

1. The sphere is directed FORWARD to Detector A at normal flow rate, until it passes completely through this detector. Closing the circulation block valve then stops the flow.
2. The direction of the flow is changed to REVERSE using the four-way valve.
3. The circulation block valve is re-opened and the sphere is now traveling in the REVERSE direction back through Detector A for a short distance until the audible or visual signal (if used) ceases. Closing the circulation block valve again stops the flow.
4. The direction of the flow is changed to FORWARD using the four-way valve.
5. The water flow is now directed through the solenoid valve, in the FORWARD direction. All the water is now passing only through the solenoid valve at a very slow flow rate.
6. At this time the pressure of the system shall be read on the downstream side of the displacer, by means of a pressure gauge that is usually installed on the waterdraw calibration unit manifold.
7. When Detector A is actuated, the solenoid valve operates and the water flow is directed into the first test measure.

The above procedure starts the filling of the first test measure. Continue until this test measure is almost full. At this time slow the filling rate into the first test measure, and at the same time direct the water into the second test measure. The second test measure is now being filled and the first test measure, being full, is closed off. If necessary the water level in the first test measure can be adjusted to a desired scale reading by the addition of water through the small filling valve. The water level in the first test measure is allowed to stabilize, the test measure is checked for level, its liquid level is read, and the temperature taken before or during draining. The test measure is then drained, in the prescribed manner.

When the second test measure is almost full, its rate is slowed, and at the same time water is directed, either back to the first test measure, or to another test measure. Once this test measure is being filled, the second test measure is closed off when the water level reaches the scale. Allow the water level to stabilize, check the test measure for level, read the liquid level on the scale and take the temperature before or during draining. The test measure is then drained in the prescribed manner.

This procedure is continued until the last test measure is being filled. When the water level reaches near to the neck of this last test measure, the main filling valve is closed off and all the water being discharged is directed back through a solenoid valve ready for an automatic shut-off at the end of the calibration pass. Once the sphere contacts the Detector B, the solenoid valve will close and the water flow into the last test measure ceases. Open the water flow to reservoir and allow the sphere to continue to pass on through Detector B.

If the sphere interchange is being used then the sphere continues to pass and will reposition itself in the receiving chamber. If the interchange is isolated or removed, then by means of the four-way valve reverse the flow. Return the displacer back around the prover calibrated section, to the upstream side of Detector A, ready to start the next pass.

The prover temperature shall be taken downstream of the second detector, at the beginning of each pass, after the sphere has passed the first detector, and after the temperature has stabilized but before it has traveled a third of the distance between the detectors. The prover pressure is taken at the beginning of each pass, downstream of the displacer, while the ball is slowly approaching the starting detector, and the water flow is being discharged only through the solenoid valve.

The calibration will end when there are three consecutive successful runs meeting the established repeatability criteria.

In all unidirectional provers, detector switch settings are critical and any adjustments will affect the prover volume. Once the calibration has been successfully completed it is recommended that the detectors be sealed in place. No adjustment of the detectors after starting the calibration is permitted. Any adjustment of the detectors following a calibration will necessitate a recalibration of the prover.

If there is difficulty in launching the ball from the launching chamber at low flow rates, it may be necessary to put two circulating pumps in parallel at least for an initial launch. This may even require starting from a less than full condition. If this is done the ball must then be run back and forth while venting all high points until all the air is evacuated and the prover refilled with water. The sphere interchange must be checked for leakage, before and at the end of each calibration run, to ensure there is no bypass through the interchange.

6.3 DISPLACEMENT TYPE BI-DIRECTIONAL PROVERS WITH FREE DISPLACERS

This section discusses provers that operate on a round-trip basis. The waterdraw calibration of a bi-directional prover is essentially the same as a unidirectional prover except that two calibration passes, in opposite directions, are required to make up a round trip run. These calibration passes, in opposite directions, do not necessarily have to agree in volume. However, all the calibration passes in the same direction, as well as all the calibration round trip runs, shall be in agreement within a range of 0.020%.

A four-way valve is required for the calibration of a bi-directional prover. If the four-way valve located on the prover being calibrated is used in the calibration, then it shall be checked for sealing integrity after each operation. Alternatively, an auxiliary four-way valve, located on or near the waterdraw unit may be used as an alternative. Whichever four-way valve is used it shall be checked for sealing integrity after each operation. If the four-way valve on the waterdraw unit is used then the four-way valve on the prover being calibrated shall be secured in one direction, leak tested, and left in place. Sometimes the four-way valve from the prover being calibrated is removed or blinded off. A trial run is sometimes helpful to work out any operational details.

Before beginning a calibration on any bi-directional displacement prover with a free displacer, the air must be vented at all high points. This includes those points, which are static during the calibration. All venting shall be done before, during, and after moving the displacer through the prover several times, by leaving the vents partially open and continuously bleeding off air and water.

Bi-directional provers with 45° launching chambers often require special attention when venting. The vent points in the ends of the launch chambers are constructed at a lower level than the top of the chamber, permitting air to be retained, which cannot be vented by ordinary means. When this occurs it may be necessary to actually loosen the end flange or door closures to complete venting of this area. The same principle of breaking open bolts, flanges or appliances holds true in other high point situations where vents are not provided.

Calibration passes through the bi-directional prover may be made using the permanently mounted four-way valve, or by using the smaller four-way valve mounted on the waterdraw unit. Owner/operator preference normally decides whether to use the permanently mounted prover four-way valve in the calibration, blind it off, or leave it permanently locked to one side or the other. Some operators prefer to use the smaller four-way valve on the waterdraw unit. Unless the large four-way valve is blinded off, both four-way valves must be checked for leakage before, and at the end of each calibration pass, to ensure there is no leakage through either of the valves. See Figures 2A and 2B.

Because bi-directional provers have a round-trip calibrated volume, consisting of both an “out” pass and a “back” pass, detector switch settings are not considered as critical as in unidirectional provers, assuming that each detector is truly bi-directional in its operation. Detectors must not be adjusted between any of the calibration runs. In the detector, the centerline of primary actuation is critical, just as in a unidirectional prover. Any adjustment of a detector switch will affect both the “out” and “back” volumes.

Each calibration run (round-trip) consists of an “out” and “back” pass. Both passes must be completed, at the same flow rate, to successfully complete a calibration run. Three consecutive round-trip runs are required for a successful bi-directional prover calibration.

It is essential that all calibration passes be conducted in the same manner as the prover is normally operated. Therefore, two consecutive passes shall never be made in the same direction. Ideally, for air elimination and temperature stability purposes, the displacer should be allowed to complete its travel at the end of any given calibration pass and return to the launching chamber. After that, it can again be repositioned at the starting detector position, ready for the next pass.

On the first pass the following starting sequence is followed to position the sphere into its starting position under the first detector switch. The detector switches are named “A” and “B”.

1. The sphere is directed FORWARD to Detector A at normal flow rate, until it passes completely through this detector. Closing the circulation block valve then stops the flow.
2. The direction of the flow is changed to REVERSE using the four-way valve.
3. The circulation block valve is re-opened and the sphere is now traveling in the REVERSE direction back through Detector A for a short distance until the audible or visual signal (if used) ceases. Closing the circulation block valve again stops the flow.
4. The direction of the flow is changed to FORWARD using the four-way valve.
5. The water flow is now directed through the solenoid valve, in the FORWARD direction. All the water is now passing only through the solenoid valve at a very slow flow rate.
6. At this time the pressure of the system shall be read on the downstream side of the displacer, by means of a pressure gauge that is usually installed on the waterdraw calibration unit manifold.
7. When Detector A is actuated, the solenoid valve operates and the water flow is directed into the first test measure.

The above procedure starts the filling of the first test measure. Continue until this test measure is almost full. At this time slow the filling rate into the first test measure, and at the same time direct the water into the second test measure. The second test measure is now being filled and the first test measure, being full, is closed off. If necessary the water level in the first test measure can be adjusted to a desired scale reading by the addition of water through the small filling valve. The water level in the first test measure is allowed to stabilize, the test measure is checked for level, its liquid level is read, and the temperature taken before or during draining. The test measure is then drained in the prescribed manner.

When the second test measure is almost full, its rate is slowed, and at the same time water is directed, either back to the first test measure, or to another test measure. Once this test measure is being filled, the second test measure is closed off when the water level reaches the scale. Allow the water level to stabilize, check the test measure for level, read the liquid level on the scale and take the temperature before or during draining. The test measure is then drained in the prescribed manner.

This procedure is continued until the last test measure is being filled. When the water level reaches near to the neck of this last test measure, the main filling valve is closed off, and all the water being discharged is directed back through a solenoid valve, ready for an automatic shut-off at the end of the calibration pass. Once the displacer contacts Detector B, the solenoid valve will close

and the water flow into the last test measure ceases. Open the water flow to drain, and allow the sphere to continue on through Detector B into the launching chamber. If the temperature is stable on a large prover, in order to save time between passes it may be possible to hold the displacer downstream of Detector B between passes. However doing so indiscriminately may result in unrepresentative prover temperatures, so care must be exercised.

The displacer should then be repositioned back to Detector B, ready for the commencement of the “back” pass, which will be conducted in exactly the same manner as the “out” pass described above, but in the reverse direction.

The prover temperature shall be taken downstream of the ending detector, at the beginning of each pass, after the displacer has passed the starting detector, and after the temperature has stabilized, but before it has traveled a third of the distance between the detectors. The prover pressure is taken at the beginning of each pass, downstream of the displacer, while the sphere is slowly approaching the starting detector for the “out” pass, and all the water is being discharged through the solenoid valve.

At the end of a successful calibration there should be three consecutive round-trip runs, consisting of six consecutive passes, all meeting the repeatability requirements, for example, labeled as follows:

“Out” Pass 1: “Back” Pass 2:= Round-trip 1

“Out” Pass 3: “Back” Pass 4:= Round-trip 2

“Out” Pass 5: “Back” Pass 6:= Round-trip 3

6.4 DISPLACEMENT TYPE METER PROVERS WITH CAPTIVE DISPLACERS

Some types of displacement provers have shafts attached to the displacer. These shafts may be continuous on both sides of the displacer, or they may be on only one side of the displacer. If the shafts are continuous and uniform in diameter on both sides of the displacer then the effective upstream volume (i.e., when the flow meter being proved is upstream of the prover) may be equal to the effective downstream volume (i.e., when the flow meter being proved is downstream of the prover). However, if the shafts are on only one side of the displacer, then the effective upstream volume will differ from the effective downstream volume. For further explanation, if the shaft is only on the upstream side of the displacer, the effective volume when a meter is proved upstream of the prover will be less than the effective volume when a meter is proved downstream of the prover. Conversely, if the shaft is only on the downstream side of the displacer, the effective volume when a meter is proved upstream of the prover will be greater than the effective volume when a meter is proved downstream of the prover. The difference in volumes is equivalent to the volume displaced by the shaft. Both volumes shall therefore be stated on the calibration certificate package(s). If only one volume is determined, the calibration certificate package shall clearly state this, and identify the side of the prover that is calibrated to ensure that only meters on this side of the prover are to be proved with this prover.

It is strongly recommended that in this type of prover both upstream and downstream prover volumes be determined. In that case, both volumes shall be determined by calibration, and both volumes shall be reported on the Calibration Certificate Package(s). The downstream volume is normally calibrated in its normal flow pattern. However, the upstream volume is often calibrated “backwards” meaning that in a unidirectional prover the displacement is from Detector Switch “B” to Detector Switch “A”.

Calibrating the upstream volume in this manner may require changing a setting in the prover controller so that:

- Seal integrity is maintained while the displacer is measuring in the “reverse” direction.
- The opposite side of the detector switch (leading vs. lagging) is used for the upstream volume so that any distortion caused by changing the direction of displacement is eliminated.

It has been found that using a four-way valve is very useful for calibrating the upstream volume of a unidirectional displacement prover with a captive displacer. Advice from the manufacturer in this procedure is highly recommended. Insertion detector switches on a pipe prover with a free displacer are usually connected in parallel using “normally open” contact switches. However, provers with captive displacers often require the use of a relay and connections to “normally closed” contact switches. Usually the manufacturer can provide a special kit for waterdraw calibration, unique to their type of prover.

As the volumes on this type of prover are small, three-way solenoid valves are normally used so that a measured run can be made without stopping the displacer at the detector switch. Field personnel, waterdraw technicians and observers should have a complete understanding of the equipment and procedures to be used on the calibration of displacement provers with captive displacers.

These types of provers are calibrated just like the displacement provers with free displacers with certain differences. Some of the features to note about provers with captive displacers are as follows:

- A captive displacer with a shaft assembly only on one end of the displacer will require the calibration of both an upstream volume and a downstream volume, so that the prover can be used to prove meters located both upstream and downstream. One of these volumes can be calibrated with the flow in its normal direction. The other volume may require that the calibration be performed in the opposite direction. See Figures 3A and 3B.
- Some prover designs allow for the calibration of this volume by the use of optical detectors, which gate at the same point regardless of direction. Optical detectors allow these provers to have smaller physical sizes and volumes than most other types of displacement provers.
- The water inventory from the ending detector to the test measure is a major factor in this type of calibration. To minimize the effects of this water inventory, the waterdraw unit should be as close as possible to the prover, and the use of smaller lines should be considered. See Appendix B.
- A single test measure is preferred that will accommodate the displaced volume between the detectors of the prover.
- A single test measure, with a high sensitive neck, is recommended for any prover less than 25 gallons.
- A captive displacer with shafts of the same diameter on both ends of the displacer may require only one calibration in a uni-directional prover. See Figure 3C.
- Waterdraw calibration shall be used to determine both upstream and downstream prover volumes. Theoretical type calculated volumes shall not be used.
- In addition to the temperature (T_p) of the water between the detectors, which is taken in the same way as for a displacement prover with a free displacer, it is necessary to determine the temperature (T_d) of the external detector mounting assembly (e.g., bar). This can be done by shading the prover during the calibration and determining its ambient temperature at the same time that the prover water temperature is determined for each pass. If it is desired to take a direct temperature of a detector mounting bar, the temperature device used for this purpose should be thermally bonded to the detector mounting bar. In any case, it is recommended that the prover be shielded from direct sunlight during the calibration.

Before beginning a calibration on any displacement prover with a captive displacer, the air must be vented at all high points. This includes those points, which are static during the calibration. All venting shall be done before, during, and after moving the displacer through the prover several times, by leaving the vents partially open and continuously bleeding off air and water.

6.5 ATMOSPHERIC TANK PROVERS

6.5.1 Tank Prover Calibration Procedures

All tank provers have an upper scale. Some of them drain to a fixed zero, and some have a lower scale graduated with a zero position. The exact nature of this zero position must be determined so that the manner, in which the prover is calibrated, agrees with the manner in which it is ultimately used.

The waterdraw calibration procedure is similar to that which is used in calibrating pipe provers, including the taking of the temperature on the prover at the beginning of the run. The prover temperature is taken just before taking the scale reading in the top neck for that run. Since both the open tank prover and the field standard test measures are at atmospheric pressure, there is no pressure reading to be taken. In calibrating a volumetric tank prover, continuous circulation is not made, but rather a filling and then a draining of the volumetric tank into the test measures. The start and stop is controlled manually or semi-automatically (while observing the scale reading) rather than automatically through detector switch and solenoid-valve combinations. On new tank provers, the neck scale increments shall also be calibrated. When the tank prover is re-calibrated, verify the neck scale.

An open tank prover may also be calibrated by water-fill, rather than by waterdraw, if it is practical to raise and support the test measures on a level plane above the tank prover. In this case the temperature of each test measure is determined by immersion of the temperature device into the test measure. The temperature device shall be withdrawn immediately prior to reading the test measure scale. The test measure is then drained into the tank prover in the prescribed manner. The temperature of the tank prover is taken at the end of the run, after reading the top neck scale.

If there is sufficient water available so that the test measures can be filled in a timely and efficient manner; and the logistics of raising the test measures overhead of the tank prover in a level condition have been worked out; then water-fill is the preferred method of calibration of the tank prover. This is because it more closely replicates the normal operating drain time of the tank prover. Calibrating by water fill has the advantage that the drain-down of the tank prover after each calibration run approximates the way the volumetric prover tank is actually used. The tank prover must be filled and drained once just prior to beginning a cal-

ibration when using the water-filling technique. Pumps can be used in the calibration of a tank prover for filling and draining, as long as they are isolated during the taking of the beginning and ending readings.

The average temperature of the water in the tank prover shall be determined by one of the following methods:

- Immersion of a temperature device into the prover tank immediately prior to the beginning reading for the waterdraw method, or immediately after the ending reading for the water-fill method.
- The use of existing tank prover temperature devices, accurate to $\pm 0.1^{\circ}\text{F}$, in conjunction with the reading of the water level.
- The reading of a temperature device in the tank prover discharge line once a steady flow rate is established, during the first third of the tank prover volume discharge, and a sufficient volume of water has been received to stabilize the temperature. This procedure is suitable only to the waterdraw method.

Determine and record the temperatures of the water in each test measure filled as described in previous sections.

All tank provers are designed and built with an upper neck containing a sight glass and scale. This upper scale normally reads the actual accumulated volume at each liquid level (e.g. 999, 1,000, 1,001 gallons etc.).

Tank provers have different bottom arrangements for measuring the “zero” level of the water in the prover tank, which may or may not contain a scale and sight glass. If a lower scale is fitted, then it should read plus or minus zero in units consistent with the upper scale. Types of tank prover bottom arrangements are as follows:

Bottom-weir type has a bottom neck beneath a lower cone. The lower neck may or may not have a sight glass and scale, but in any case it has a fixed bottom “zero” defined by the weir. When the liquid level approaches the bottom, the drain valve is closed with the pump running, and the weir is used to drain the remaining water to a fixed “zero”. This arrangement is shown in Figure 4A.

Dry-bottom type usually does NOT have a bottom neck beneath a lower cone. The closed bottom drain valve defines the bottom “zero” just as on a field standard test measure. When the liquid level approaches the bottom, the drain valve is closed with the pump running, and the remaining water is drained for a fixed time interval. This arrangement is shown in Figure 4B.

Wet-bottom type has a bottom neck, with a sight glass and scale, beneath a lower cone. The bottom “zero” is defined by the “zero” on the scale, but in practice, readings in the lower neck, above and below the “zero”, are common. Thus, when filling this type of tank prover, a starting reading above the bottom “zero” would reduce the calibrated volume for that run. When the liquid level approaches the bottom, the drain valve is closed with the pump running, and the remaining water is drained to “zero” or some readable scale position on the lower scale. This arrangement is shown in Figure 4C.

6.5.2 General Considerations for Calibration

Tank provers are normally calibrated at atmospheric pressure using field standard test measures. This involves either the volume of water withdrawn from the full tank prover (i.e., waterdraw method) into field standard test measures, or the determination of the volume of water taken from field standard test measures to fill the tank prover (i.e., water-fill method). Tank provers are typically calibrated by withdrawing water into field standard test measures. However, in certain installations it may be expedient to calibrate by the water-fill method. The water-fill method has the advantage of more closely duplicating the clingage aspect of normal operation. Two calibration runs for tank provers are normally made, the scale is then adjusted, and a third run is made as confirmation of the calibration. Some parties may choose to use a scale factor rather than adjusting the scale. For example, this would be done if the scale(s) could not be moved and the Base Prover Volume determined by waterdraw (or water-fill) did not agree with the nominal volume on the scale. In either case it is valuable to create a chart of the volume deviations between calibrations.

The following general procedures apply to the calibration of both permanently installed and portable tank provers:

- The tank prover shall be internally clean. Inspect and remove any foreign objects from the tank prover and test measure(s).
- Assure that both the tank prover and test measures are plumb and level.
- All pipe work, equipment and instrumentation that affect the internal volume of the tank prover, such as spray lines, temperature sensors, and gauge glasses, shall be in place.
- Tank provers, test measures including all valves, fittings, and blinds that hold the test liquid shall be checked for leaks.
- Provisions should be made for convenient filling and withdrawal of the test liquid.
- When a pump is used in a waterdraw calibration of a tank prover, care should be taken to avoid misrepresentation of the calibrated volume due to air entrapment, hose expansion, etc. Therefore, it is important to follow a repeatable sequence of actions to ensure accurate measurement of the prover volume. It is important that the pump and valve conditions at the start and end of each calibration run are consistent.

In the waterdraw method, the tank prover is filled with water to a level on the upper sight glass scale. The test measure(s) are filled and then drained before starting the calibration run. The water is now “withdrawn” from the tank prover into the field standard test measure(s). The calibration run is considered to be complete when the water level in the tank prover reaches zero. Liquid levels and temperatures are read and recorded during the calibration run.

6.5.3 Temperature Stability

The calibration of tank provers may be simplified, when possible, by placing the tank prover, field standard test measures, and the liquid in a constant temperature enclosure for enough time to allow the equipment and the test liquid to reach an equilibrium temperature. The calibration should preferably be conducted under these conditions to minimize the temperature changes of the equipment and test liquid during the calibration. Appendix B addresses effects of temperature changes on the interface inventory.

To prevent the accumulation of air bubbles on the inside of the tank prover walls, the tank prover should not be allowed to stand full of water any longer than necessary before starting the calibration.

6.5.4 Calibration of Upper and Lower Neck Scales

The following procedure describes the method of calibrating an upper neck scale of a tank prover using water as a calibrating liquid.

Remove any floating debris by filling the tank prover with water and allowing it to overflow. Allow it to stand for several minutes until all the debris has floated to the surface at which time the debris can be flushed off. All drain valves should be flushed and then checked for leaks. The withdrawal line must be free from air. After filling, the water source shall be disconnected or removed from the tank prover.

The water draw-off valve is opened slightly until the water level appears at the extreme top of the upper gauge glass scale. The valve is then closed. This point should be temporarily marked on the neck scale. Decrements should be marked on the neck scale as the water is withdrawn from the tank prover into the selected test measure(s). When the level approaches the midpoint of the upper gauge glass at the completion of a whole decrement, a reference mark should be made and identified as the assumed upper reference level. Withdrawals should be continued, and the scale should be marked, as before, as long as the liquid level remains in sight in the upper gauge glass. These measured divisions may be subdivided as required to complete the calibration of the upper neck scale. Then the main body of the tank prover is emptied down to the top of the lower sight glass. The lower neck scale is calibrated as a separate exercise in a similar manner, except on a bottom-weir type prover where the zero mark on the lower neck scale is aligned with the weir level. Following the calibration of the upper and the lower neck scale, the prover tank is re-filled with water to begin the main calibration.

If it is determined that an existing scale does not accurately define the incremental volume in the neck of the prover tank, a new scale must be made or purchased. This is usually done by measuring the vertical linear distance from the reference mark on the lower part of the neck to the reference mark on the upper part of the neck as described above. The volume measured between these marks is subdivided into suitable increments, and the corresponding linear increments calculated. A new scale is prepared or purchased according to these measurements. When the new scale has been installed, it shall be aligned so that the nominal scale volume is lined up with the actual Base Prover Volume, as determined by the calibration of the tank prover.

If it is determined that an existing scale does not accurately define the incremental volume in the neck of the tank prover, and if it is impractical to make or purchase a new scale in the time allowed before putting the tank prover back into service, then a scale correction factor can be calculated. This scale correction factor would apply only to the neck portion of the tank prover volume that is above or below the liquid level, where the Base Prover Volume is defined by the calibration of the tank prover. This scale correction factor shall be fully described and reported on the calibration certificate package.

If it is determined that an existing scale does not have a nominal volume equal to the actual Base Prover Volume as determined by calibration of the tank prover, and if it is impractical to make or purchase a new scale in the time allowed before putting the tank prover back into service, a scale offset can be calculated. This offset value (either plus or minus a fixed volume) shall be fully described and reported on the calibration certificate package.

If it is determined that an existing scale does not accurately define the incremental volume in the neck of the tank prover, and does not have a nominal volume equal to the actual Base Prover Volume, as determined by calibration of the tank prover, and if it is impractical to make or purchase a new scale in the time allowed before putting the tank prover back into service, then both a scale

correction factor and a fixed volume offset value must be calculated. Both the scale correction factor and the fixed offset value shall be fully described and reported on the calibration certificate package.

6.5.5 Tank Provers with “Zero” at Bottom Weir in Bottom Neck (Wet Bottom Type)

Water is withdrawn from the main body of the tank prover, through the weir valve to waste, until the water level is at the upper reference level. Measured withdrawals are then made through the main discharge valve and pump until reaching the upper portion of the lower neck scale.

The main discharge valve is then closed. The weir valve is opened to draw the remaining water, into a small pre-wetted container, down to the weir “zero”. The weir valve is left open for the prescribed draining time. This water is then measured by pouring it into one or more of the filled test measures. The prescribed draining time is defined as continuing to drain through the weir valve for a fixed period of time after the cessation of the main flow. This prescribed draining time, of no less than 30 seconds, is determined prior to the start of the calibration by consensus or past experience. The prescribed draining time is typically 30 or 60 seconds in length. The selected draining time shall be the same for all calibration runs and shall be reported in the final Calibration Certificate Package. This calibration should be repeated until two or more consecutive volumes, after corrections, agree within a range of 0.020 %. The average of the consecutive tank prover volumes shall be used as the initial calibrated volume of the tank prover, which is the volume between the upper reference level and the weir level. The upper neck scale should then be aligned so that the calibrated volume of the tank prover at the reference level aligns with the scale reading for that volume. Following the adjustment of the upper neck scale, a final calibration run is made to verify that the scale adjustment is correct within 0.010 % of the target volume (e.g., 500 gallons, 1000 gallons, etc.).

The final operation is to permanently mark the upper reference level, and all graduations on the upper scale. Attach the scales securely and permanently to the tank prover necks, sealing them to prevent unintentional or unauthorized movement. If the scales cannot be adjusted, a notation is made on the calibration certificate package stating how much to add or subtract to the indicated tank prover volume.

6.5.6 Tank Provers with “Zero” at Bottom Drain Valve (Dry Bottom Type)

The following procedure describes the waterdraw method to calibrate a tank prover with a top neck and a bottom drain valve as the lower reference level at standard conditions, using water as the calibrating liquid. In general, water is withdrawn from the main body of the tank prover through the main discharge valve to waste until the water level is at the upper reference level. Measured withdrawals are then made through the main discharge valve and pump until reaching the lower portion of the lower cone.

The main discharge valve is closed, if applicable, the pump is turned off, and the hose is then disconnected. A small pre-wetted container is positioned under the discharge valve, which is carefully opened so that the remaining water can be captured. The main discharge valve is left in the fully open position for the prescribed draining time. This water is then measured by pouring it into one or more of the filled test measures. The prescribed draining time is defined as continuing to drain through the main discharge valve for a fixed period of time after the cessation of the main flow. This prescribed draining time, of no less than 30 seconds, is determined prior to the start of the calibration by consensus or past experience. The prescribed draining time is typically 30 or 60 seconds in length. The selected draining time shall be the same for all calibration runs and shall be reported in the final Calibration Certificate Package.

This calibration should be repeated until two or more consecutive volumes, after corrections, agree within a range of 0.020%. The average of the consecutive tank prover volumes shall be used as the initial calibrated volume of the tank prover, which is the volume between the upper reference level and the dry bottom. The upper neck scale should then be aligned so that the calibrated volume of the tank prover at the reference level aligns with the scale reading for that volume. Following the adjustment of the upper neck scale, a final calibration run is made to verify that the scale adjustment is correct within 0.010% of the target volume (e.g., 500 gallons, 1000 gallons, etc.).

The final operation is to permanently mark the upper reference level, and all graduations on the upper scale. Attach the scale securely and permanently to the tank prover neck, sealing it to prevent unintentional or unauthorized movement. If the scale(s) cannot be adjusted, a notation is made on the Calibration Certificate Package stating how much to add or subtract to the indicated tank prover volume.

6.5.7 Tank Provers with “Zero” on Scale at Bottom Neck (Wet Bottom Type)

Water is withdrawn from the main body of the tank prover, through the lower neck drain valve (usually located just below the lower scale) to waste, until the water level is at the upper reference level. Measured withdrawals are then made through the main discharge valve and pump until reaching the upper portion of the lower neck scale.

The main discharge valve is then closed. The lower neck drain valve is then opened to draw the remaining water into a small pre-wetted container. The lower neck drain valve is left open for the prescribed draining time. This water is then measured by pouring it into one or more of the filled test measures. The prescribed draining time is defined as continuing to drain through the lower neck drain valve for a fixed period of time after the cessation of the main flow. This prescribed draining time, of no less than 30 seconds, is determined prior to the start of the calibration by consensus or past experience. The prescribed draining time is typically 30 or 60 seconds in length. This draining time shall be the same for all calibration runs and shall be reported in the final Calibration Certificate Package.

This calibration should be repeated until two or more consecutive volumes, after corrections, agree within a range of 0.020%. The average of the consecutive tank prover volumes shall be used as the initial calibrated volume of the tank prover, which is the volume between the upper reference level and the lower reference level. The upper neck and the lower neck scales should then be aligned so that the calibrated volume of the tank prover at the reference levels aligns with the scale readings for that volume. Following the adjustment of the upper neck scale and/or the lower neck scale, a final calibration run is made to verify that the scale adjustments are correct within 0.010% of the target volume (e.g., 500 gallons, 1000 gallons, etc.).

The final operation is to permanently mark the upper and lower reference levels, and all graduations on both scales. Attach the scales securely and permanently to the tank prover necks, sealing them to prevent unintentional or unauthorized movement. If the scale(s) cannot be adjusted, a notation is made on the Calibration Certificate Package stating how much to add or subtract to the indicated tank prover volume.

7.0 Calibration Procedures By Type Of Prover

7.1 CALIBRATION PREPARATION

Before beginning any waterdraw calibration the following items shall be verified:

- That the prover and its piping:
 - Have been inspected beforehand for good condition of coating.
 - Have been thoroughly cleaned of hydrocarbons.
 - Have been cleaned of dirt and debris.
- That any sphere type displacer being used:
 - Has been checked for condition including roundness and smoothness.
 - Has been checked for liquid fullness and correct sizing.
- That any piston type displacer being used has been checked for proper size and condition of seals.
- That any thermowell being used:
 - Is inserted to the middle third of the pipe.
 - Is inserted in the flowing stream and not in a dead leg.
 - Is inserted in a small enough diameter pipe to allow accurate readings.
- That the detector switches on displacement provers are in good condition, clean, and properly adjusted.
- That the prover and all auxiliary “dead-space” piping:
 - Have been isolated with blinds or valves
 - Have been made water-clean and re-filled with fresh water.
- That the quality of the water to be used for the waterdraw calibration work is suitable for the calibration.
- That all drain valves, relief valves, vent valves and manifold valves are sealing properly when closed.
- That all hoses and connections from the waterdraw unit to the prover are in good condition and leak free.
- That all the piping and closed valves, including solenoid valves, in the waterdraw unit have been verified to be leak free.
- That any four-way valves or sphere interchanges being used are operating and sealing properly.
- That the water has been circulating through the displacement prover and the temperature has stabilized.
- That an atmospheric tank prover has remained full of water, until air free and the temperature is stabilized.
- That the atmospheric tank prover has been checked for level while full of water.

- That all thermometers to be used in the waterdraw have been verified for condition and are in agreement with a certified or calibrated thermometer within a range of 0.1°F (0.05°C).
- That any pressure gauge used in the waterdraw calibration has been calibrated or certified to be accurate to 1 psig.
- That the documentation on the thermometers and the pressure gauges has been inspected for traceability and current status.
- That the documentation on the Field Standard Test Measures has been examined for traceability and current status.
- That the documentation and equipment/calibration identification numbers have been checked to match.
- That the test measures being used have all been:
 - Inspected for cleanliness, freedom from dents and integrity of NIST identification seals.
 - Checked to ensure that the sight glasses and closed drain valves do not leak.
 - Filled with water and then made level when full of water as prescribed.
- That the launching chambers and interchanges have been vented before the start of each pass of the displacer.
- That all high points, where air could possibly be trapped, have been vented.
- That the detector switches are connected to the waterdraw unit and operating correctly.
- That the waterdraw unit is functioning correctly.

7.2 DISPLACEMENT TYPE UNIDIRECTIONAL PROVERS WITH FREE DISPLACERS

During each calibration pass, determine the flow rate by one of the following methods:

- Using a flow meter to monitor the flow rate while adjusting the filling valve(s)
- Timing the filling of the largest test measure being used.
- Timing the entire calibration pass [(total volume/time) = flow rate].

During each calibration pass:

- Record all temperature readings to the nearest 0.1°F
- Record all pressure readings to the nearest 1.0 psig

Recommended steps typically include:

Preliminary

1. Identify the first and second detector switches (e.g. “A” and “B”) that will be used for each pass/run.
2. Verify that the four-way valve is positioned so that the flow is in the “out” direction.
3. Maintain continuous water circulation through the prover and waterdraw unit.
4. Re-fill any test measure(s) that are empty or partially filled.
5. After filling verify that all the test measures are level.
6. Verify that all block valves downstream of the solenoid valve(s) are closed.
7. Drain each test measure in the manner prescribed by its Report of Calibration.

Calibration Pass

8. Determine and maintain the prescribed flow rate for this pass.
9. All high point vents in the prover system should be checked for air before starting a new pass.
10. Launch the displacer while circulating through the main bypass valve into the reservoir.
11. If being used, verify the integrity of the seal of the interchange.
12. Allow the displacer to go a short distance past the “A” detector in the “out” direction.
13. Use the four-way valve to reverse the flow to bring the ball “back” across the “A” detector.
14. When the ball has gone several seconds past the “A” detector switch, close the bypass valve.
15. Operate the four-way valve to re-direct the flow to the “out” direction but with the flow stopped.
16. Check the four-way valve for sealing integrity.
17. Set the controller so that the solenoid valve is open to reservoir.
18. Open the solenoid isolation valve to allow water to flow directly into the reservoir.
19. As the displacer moves toward the “A” detector switch, observe and record the pressure.
20. Upon actuation of the “A” detector switch, the solenoid valve will close to reservoir.
21. The flow to reservoir is automatically stopped and all flow has ceased.
22. Close the solenoid isolation valve in-line with the now closed solenoid valve.

23. Open the filling valve of the first test measure at the prescribed flow rate for this pass. All the water is now being measured.
24. Read the prover temperature for this pass after reaching stability and within the first third of the measured volume.
25. When the first test measure is near being full, begin to throttle its filling valve.
26. Simultaneously (as practical) begin opening the filling valve of the second test measure.
27. Open the filling valve of the second test measure to the prescribed flow rate while closing the filling valve to the first test measure.
28. Once the first test measure is full, close its filling valve and let the contents stabilize.
29. Verify that the first test measure is level before reading the scale.
30. Read the scale at the bottom of the water meniscus in the prescribed manner.
31. Take the temperature after the water level is read, before or during the draining of the first test measure.
32. Drain the first test measure in the prescribed manner.
33. Stop the draining of the test measure upon reaching the time prescribed on its Report of Calibration, ready to be re-filled again as required.
34. Fill, read the water level, read the temperature and drain each test measure in a continuous manner.
35. Rotate the filling and draining from one test measure to the next, until the final test measure is being filled.
36. When the last test measure is almost full, open the solenoid isolation valve to this test measure.
37. Close the main filling valve for this field standard test measure.
38. Upon actuation of the “B” detector switch, the solenoid valve stops the water flow into the last test measure.
39. Close the solenoid isolation valve to this test measure.
40. Open the main bypass valve and allow the displacer to go past the “B” detector switch.
41. Take the final readings and drain this last test measure as on all the other test measures to complete this pass/run.
42. If using the prover interchange, allow the displacer to continue back into the interchange and the water circulation to continue until the next launch.
43. If not using the prover interchange:
 - a. Reverse the four-way valve so that the flow is going in the “back” direction
 - b. Allow the displacer to travel back across the “B” detector switch and the “A” detector switch.
 - c. Allow the displacer to go only a short distance past the “A” detector switch and stop the flow.
44. Close the main bypass valve before the next launch.
45. Vent all high points in the prover system before each pass.
46. Position the four-way valve so that flow will be in the “out” direction.
47. If closed, open the main bypass valve.
48. Repeat Steps 8 through 47 until all the criteria for a satisfactory calibration have been satisfied.

Refer to 6.1.14 for calculation and repeatability requirements. Even when all the repeatability criteria have been met, the calibration may be continued if in the opinion of all the interested parties, doubt about the integrity of the final calibrated volume has been introduced.

7.3 DISPLACEMENT TYPE BI-DIRECTIONAL PROVERS WITH FREE DISPLACERS

During each calibration pass, determine the flow rate by one of the following methods:

- Using a flow meter to monitor the flow rate while adjusting the filling valve(s)
- Timing the filling of the largest test measure being used.
- Timing the entire calibration pass [(total volume/time) = flow rate].

During each calibration pass:

- Record all temperature readings to the nearest 0.1°F
- Record all pressure readings to the nearest 1.0 psig

The calibration can be conducted by starting from either launching chamber. For purposes of this discussion, it will be assumed that the four-way valve on the prover being calibrated is being used. Also, that the displacer (ball or piston) is sitting in the “home” position and that the four-way valve is in the “reverse” direction so that the water is circulating in the “back” direction.

Recommended steps typically include:

Preliminary

1. Identify the first and second detector switches (e.g. “A” and “B”) that will be used for each pass/run.
2. Verify that the four-way valve is positioned so that the flow is in the “back” direction.
3. Maintain continuous water circulation through the prover and waterdraw unit.
4. Re-fill any test measure(s) that are empty or partially filled.
5. After filling verify that all the test measures are level.
6. Verify that all isolation valves downstream of the solenoid valve(s) are closed.
7. Drain each test measure in the manner prescribed by its Report of Calibration.

Out Pass

8. Determine and maintain the prescribed flow rate for this pass.
9. All high point vents in the prover system should be checked for air before starting a new pass.
10. Launch the displacer by positioning the four-way valve in the “out” direction.
11. Allow the displacer to go a short distance past the “A” detector switch in the “out” direction.
12. Use the four-way valve to reverse the flow to bring the ball “back” across the “A” detector switch.
13. When the ball has gone several seconds past the “A” detector switch, close the bypass valve.
14. Operate the four-way valve to re-direct the flow to the “out” direction but with the flow stopped.
15. Check the four-way valve(s) for sealing integrity.
16. Set the controller so that the solenoid valve is open to the reservoir.
17. Open the solenoid isolation valve to allow water to flow directly into the reservoir.
18. As the displacer moves toward the “A” detector switch, observe and record the pressure.
19. Upon actuation of the “A” detector switch the solenoid valve will close to reservoir.
20. The flow to the reservoir is automatically stopped and all flow has ceased.
21. Close the solenoid isolation valve in-line with the now closed solenoid valve.
22. Open the filling valve of the first test measure at the prescribed flow rate for this “out” pass. All the water is now being measured.
23. Read the prover temperature for this pass after reaching stability and within the first third of the measured volume.
24. When the first test measure is near being full, begin to throttle its filling valve.
25. Simultaneously (as practical) begin opening the filling valve on the second test measure.
26. Open the second filling valve to attain the prescribed flow rate while closing the first filling valve.
27. Once the first test measure is full, close the filling valve and let the contents stabilize.
28. Verify that the first test measure is level before reading the scale.
29. Read the water level at the bottom of the water meniscus on the scale in the prescribed manner.
30. Take the temperature after the water level is read, before or during the draining of the first test measure.
31. Drain the first test measure in the prescribed manner.
32. Stop the test measure draining upon reaching the time prescribed on its Report of Calibration, ready to be re-filled again as required.
33. Fill, read the water level, read the temperature and drain each test measure in a continuous manner.
34. Rotate the filling and draining from one test measure to the next, until the final test measure is being filled.
35. When the last test measure is almost full, open the solenoid isolation valve to this test measure.
36. Close the main filling valve for this field standard test measure.
37. Upon actuation of the “B” detector switch the water flow into the last test measure is stopped.
38. Close the solenoid isolation valve to this test measure.
39. Open the main bypass valve and allow the displacer to go past the “B” detector switch.
40. It is recommended that the displacer be allowed to continue to near or into the launching chamber.
41. Take the final readings and drain this last test measure as on all the other test measures to complete this “out” pass.
42. Water circulation should go on continuously until the next launch to maintain temperature stability.

Back Pass

43. Determine and maintain the prescribed flow rate for this pass.
44. All high point vents in the prover system should be checked for air before starting a new pass.
45. To commence the next pass, launch the displacer by positioning the four-way valve in the “back” direction.

46. Allow the displacer to go a short distance past the “B” detector switch in the “back” direction.
47. Use the four-way valve to reverse the flow to bring the ball “out” across the “B” detector switch.
48. When the ball has gone several seconds past the “B” detector switch, close the bypass valve.
49. Operate the four-way valve to re-direct the flow to the “back” direction but with the flow stopped.
50. Check the four-way valve(s) for sealing integrity.
51. Set the controller so that the solenoid valve is open to the reservoir.
52. Open the solenoid isolation valve to allow water to flow directly into the reservoir.
53. As the displacer moves toward the “B” detector switch, observe and record the pressure.
54. Upon actuation of the “B” detector switch the solenoid valve will close to the reservoir.
55. The flow to the reservoir is automatically stopped and all flow has ceased.
56. Close the solenoid isolation valve in-line with the now closed solenoid valve.
57. Open the filling valve to the first test measure at the prescribed flow rate for this “back” pass. All the water is now being measured.
58. Read the prover temperature for this pass after reaching stability and within the first third of the measured volume.
59. When the first test measure is near being full, begin to throttle its filling valve.
60. Simultaneously (as practical) begin opening the filling valve of the second test measure.
61. Open the second filling valve to the prescribed flow rate while closing the first filling valve.
62. Once the first test measure is full, close its filling valve and let the contents stabilize.
63. Verify that the first test measure is level before reading the scale.
64. Read the water level at the bottom of the water meniscus on the scale in the prescribed manner.
65. Take the temperature after the water level is read, before or during the draining of the first test measure.
66. Drain the first test measure in the prescribed manner.
67. Stop the test measure draining upon reaching the time prescribed on its Report of Calibration, ready to be re-filled again as required.
68. Fill, read the water level, read the temperature and drain each test measure in a continuous manner.
69. Rotate from one test measure to the next, until the final test measure is being filled.
70. When the last test measure is almost full, open the solenoid isolation valve to this test measure.
71. Close the main filling valve for this field standard test measure.
72. Upon actuation of the “A” detector switch the water flow into the last test measure is stopped.
73. Close the solenoid isolation valve to this test measure.
74. Open the main bypass valve and allow the displacer to go past the “A” detector switch.
75. It is recommended that the displacer be allowed to continue to near or into the launching chamber.
76. Take the final readings and drain as with all the other test measures to complete this “back” pass.
77. This completes one round trip run composed of one “out” pass and one “back” pass.
78. Water circulation should go on continuously until the next launch to maintain temperature stability.
79. All the high points in the prover system should be vented before each pass.
80. Repeat Steps 8 through 79 until the criteria for a satisfactory calibration have been satisfied.

Refer to 6.1.14 for calculation and repeatability requirements. Even when all the repeatability criteria have been met, the calibration may be continued if in the opinion of all the interested parties, doubt about the integrity of the final calibrated volume has been introduced.

7.4 DISPLACEMENT TYPE METER PROVERS WITH CAPTIVE DISPLACERS

During each calibration pass, determine the flow rate by one of the following methods:

- Using a flow meter to monitor the flow rate while adjusting the filling valve(s)
- Timing the filling of the largest test measure being used.
- Timing the entire calibration pass [(total volume/time) = flow rate].

During each calibration pass:

- Record all temperature readings to the nearest 0.1°F
- Record all pressure readings to the nearest 1.0 psig

Verify that correct connections have been made to the detector switches and prover controller. Establish a stable water circulation flow rate, verify that all air has been vented, and confirm the integrity of all seals against any leak paths (internal and external). After optimum ambient conditions have been reached, perform the following steps if required:

Recommended steps typically include:

7.4.1 Downstream Volume

Preliminary

1. Confirm that all the detector switch connections are set for calibrating the DOWNSTREAM volume.
2. Confirm that all the controller options are set for calibrating the DOWNSTREAM volume.
3. Fill, level, and drain the test measure(s) in the prescribed manner. It is preferable that only one high-sensitivity test measure of suitable volume be used.

Calibration Pass

4. Determine and maintain the prescribed flow rate for this pass.
5. Confirm that the water temperature has reached a stable condition.
6. Return the displacer to its starting position.
7. Launch the displacer with flow going to waste through a solenoid valve.
8. Record the pressure as the displacer approaches the “A” detector switch.
9. When the displacer actuates the “A” detector switch the solenoid valve operates and diverts the flow into the test measure.
10. If required, a manual manifold valve can be used to increase the water flow rate into the test measure.
11. Read the prover temperature and the prover detector temperature for this pass after reaching stability and within the first third of the measured volume.
12. When the displacer approaches the “B” detector switch slow the flow rate and direct all the water flow through the solenoid valve.
13. When the displacer actuates the “B” detector switch, the solenoid valve will operate, and all the water flow will be diverted to waste.
14. Allow the water flow to continue through the prover.
15. Verify that the test measure is level, and read the water level at the bottom of the meniscus on the test measure scale.
16. The temperature shall be read immediately after the water level is read, either before or during the draining process.
17. Stop the test measure draining upon reaching the time prescribed on its Report of Calibration, ready to be re-filled again as required.
18. Repeat steps 4 through 17 for each consecutive calibration pass/run.
19. After three calibration pass/runs, evaluate the results for repeatability criteria.

Refer to 6.1.14 for calculation and repeatability requirements. Even when all the repeatability criteria have been met, the calibration may be continued if in the opinion of all the interested parties, doubt about the integrity of the final calibrated volume has been introduced.

7.4.2 Upstream Volume

Preliminary

1. Confirm that all the detector switch connections are set for calibrating the UPSTREAM volume.
2. Confirm that all the controller options are set for calibrating the UPSTREAM volume.
3. Fill, level, and drain the test measure(s) in the prescribed manner. It is preferable that only one high-sensitivity test measure of suitable volume is used.

Calibration Pass

4. Determine and maintain the prescribed flow rate for this pass.
5. Confirm that the water temperature has reached a stable condition and that the water flow is in the same direction as in the normal operation of the prover.
6. Using the four-way valve, reverse the flow from the normal operating direction of the prover.
7. Launch the displacer in the direction of Detector Switch “B” to Detector Switch “A” using the four-way valve.
8. All flow should be going to waste through the solenoid valve.

9. Record the pressure as the displacer approaches the “B” detector switch.
10. When the displacer actuates the “B” detector switch, the solenoid valve operates and diverts all of the water flow into the test measure.
11. If required, a manual manifold valve can be used to increase the water flow rate into the test measure.
12. Read the prover temperature and the prover detector temperature for this pass after reaching stability and within the first third of the measured volume.
13. When the displacer approaches the “A” detector switch, slow the flow rate and direct all the water flow through the solenoid valve.
14. When the displacer actuates the “A” detector switch, the solenoid valve will operate, and all the water flow will be diverted to waste.
15. Allow the flow to continue through the prover.
16. Verify that the test measure is level, and read the water level at the bottom of the meniscus on the test measure scale.
17. The temperature shall be read immediately after the water level is read, either before or during the draining process.
18. Stop the test measure draining upon reaching the time prescribed on its Report of Calibration, ready to be re-filled again as required.
19. Repeat steps 4 through 18 for each consecutive calibration run.
20. After three calibration pass/runs, evaluate the results for repeatability criteria.

Refer to 6.1.14 for calculation and repeatability requirements. Even when all the repeatability criteria have been met, the calibration may be continued if in the opinion of all the interested parties, doubt about the integrity of the final calibrated volume has been introduced.

7.5 ATMOSPHERIC TANK PROVERS

During each calibration run:

- Record all temperature readings to the nearest 0.1°F
- Record all pressure readings to the nearest 1.0 psig

Recommended steps typically include:

7.5.1 Waterdraw Method (drawing water from prover into test measures)

1. Fill the atmospheric tank prover full to the brim with fresh water and float off any light debris.
2. Open the discharge valve to flood the pump suction, then start the pump.
3. Draw some water from the tank prover discharge with the pump into the waterdraw calibration unit.
4. Vent all high points in the system from the tank prover through the waterdraw unit.

Upper Neck Scale Verification

5. Re-fill the prover full to brim, and then draw down the water level to a low position in the upper neck of the tank prover.
6. With the pump still running, close the tank prover bottom drain valve, upstream of the pump suction.
7. The pump may now be shut down
8. Determine the temperature of the water in the prover tank using temperature devices located in thermowells or by means of the immersion method.
9. Read and record the water level of the tank prover at the bottom of the meniscus on the upper scale.
10. Fill with water, a small overhead drain type test measure. A one, two or five-gallon test measure is often used.
11. Stir the water and determine its temperature before reading the water level on the scale of this small test measure.
12. Empty this small test measure into the prover tank using the prescribed draining time.
13. Repeat steps 10 through 12 until the water level is high in the upper neck.
14. Read and record the water level of the prover tank at the bottom of the meniscus on the upper scale.
15. Determine the temperature of the tank prover water.
16. Evaluate the results to see if the indicated volume in the upper neck is in agreement with its scale.
17. Repeat steps 1 through 17 on all new prover tanks.
18. Repeat steps 1 through 17 if there is any indication of neck scale error.
19. Determine whether or not a new scale is required.

Tank Prover Calibration

20. Fill the atmospheric tank prover full to the brim with fresh water and float off any light debris.
21. Open the tank prover discharge valve to flood the pump suction and then start the pump.
22. Draw some water from the tank prover discharge with the pump into the waterdraw calibration unit.
23. Vent all the high points in the system from the tank prover through waterdraw unit.
24. Fill all the field standard test measures being used with fresh water.
25. Verify all field standard test measures being used are level when full.
26. Drain the test measures in the prescribed manner
27. Re-fill the tank prover full to the brim and then draw the water back down to a level just above the desired target volume.
28. Determine the temperature of the water in the tank prover by using temperature devices located in thermowells or by means of the immersion method.
29. Slowly draw the water level down until it is exactly at the desired target volume position.
30. Close the discharge valve upstream of the pump.
31. Determine the exact water level reading at the bottom of the meniscus on the upper neck scale of the tank prover.
32. Re-open the tank prover discharge valve.
33. Open the filling valve into the first test measure to be filled.
34. If using a thermowell in the tank prover discharge line, read the prover temperature for this run after reaching stability and within the first third of the measured volume.
35. When the first test measure is near being full, begin to throttle its filling valve.
36. Simultaneously (as practical) begin opening the filling valve of the second test measure
37. Open the filling valve of the second test measure while closing the filling valve of the first test measure.
38. Once the first test measure is full, close its filling-valve and let the water contents stabilize.
39. Read the water level at the bottom of the meniscus on the test measure scale in the prescribed manner.
40. Take the temperature after the water level is read, before or during the draining of the first test measure.
41. Drain the first test measure in the prescribed manner.
42. Stop the test measure draining upon reaching the time prescribed on its Report of Calibration (e.g., usually 30 seconds after cessation of the main flow), ready to be re-filled again as required.
43. Fill each test measure, read each level, take each temperature and drain each test measure in a continuous manner.
44. Rotate from one test measure to the next, until the water level in the tank prover is near zero.
45. If the prover has a lower neck and scale, which enables the bottom level to vary, slowly draw the water level down to zero.
 - When at or near the zero mark on the scale, close the tank prover discharge valve, thus isolating the tank prover from the pump.
 - Read the water level at the bottom of the meniscus on the lower neck scale.
46. If the tank prover has a fixed zero and weir, slowly draw the water level down to just above the zero mark and the weir.
 - Close the discharge valve, thus isolating the tank prover from the pump.
 - Wet down a small test measure or smooth wall transfer container in the prescribed manner.
 - Draw down the water level using the side outlet at the weir position on the tank prover lower neck until the flow stops.
 - Transfer this small final amount of water into a test measure that still has space in the neck to hold this additional water.
47. If the tank prover has a “dry” bottom, slowly draw the water down to near zero.
 - Close the tank prover discharge valve, thus isolating the tank prover from the pump.
 - Turn off and disconnect the pump.
 - Wet down a small test measure or other smooth wall transfer container in the prescribed manner.
 - Open the tank prover discharge valve and allow the remaining water to flow into the small transfer container.
 - Allow the tank prover to drain in the prescribed manner.
 - Transfer this final amount of water into a test measure that still has space in the neck to hold this additional water.
48. Take all final water level and temperature readings on the last test measure(s).
49. This completes one calibration run.
50. Repeat steps 20 through 49 until two consecutive runs agree within 0.020%
51. Evaluate these results to see how close the average calibrated volume is to the target volume.
52. Make an appropriate adjustment of the upper and/or lower scale(s) to make the scale reading(s) agree with the average calibrated volume.
53. After adjustment of the scale(s), repeat steps 20 through 49.
54. Determine the calibrated volume of the tank prover for this third run.
 - If this run does not confirm the target volume within 0.010%, the calibration shall be continued.
 - If this run does confirm the target volume within 0.010%, then seal the neck scale(s) in place.

55. This completes the calibration.

56. If the scales are not moveable steps 52, 53 and 54 do not apply, and a notation is put onto the Calibration Certificate Package showing the difference between the “target” volume and the actual Base Prover Volume determined.

Refer to 6.1.14 for calculation and repeatability requirements. Even when all the repeatability criteria have been met, the calibration may be continued if in the opinion of all the interested parties, doubt about the integrity of the final calibrated volume has been introduced.

7.5.2 Water-Filling Method (drawing water from test measures into prover)

1. Position one or more, appropriately sized test measures overhead of the tank prover.
2. Fill the test measures with water, verify that they are level and that their platform is stable.

Upper Neck Scale Verification

3. Fill the atmospheric tank prover full to the brim with fresh water and float off any light debris.
4. Draw the some water from the tank prover discharge valve down to a low position in the upper neck of the tank prover.
5. Determine the temperature of the water in the prover tank by using temperature devices located in thermowells or by means of the immersion method.
6. Read and record the water level of the prover tank at the bottom of the meniscus on the upper scale.
7. Fill with water, a small overhead drain type test measure. A one, two or five-gallon test measure is often used.
8. Stir the water and determine its temperature before reading the scale of this small test measure.
9. Read the scale of the small test measure at the bottom of the meniscus.
10. Empty this small test measure into the prover tank using the prescribed draining time.
11. Repeat steps 7 through 11 until the water level is high in the upper neck.
12. Read and record the water level at the bottom of the meniscus on the upper scale of the tank prover.
13. Determine the temperature of the tank prover water.
14. Evaluate the results to see if the indicated volume in the upper neck is in agreement with its scale.
15. Repeat steps 1 through 14 on all new prover tanks.
16. Repeat steps 1 through 14 if there is any indication of neck scale error.
17. Determine whether or not a new scale is required.

Tank Prover Calibration

18. Fill the atmospheric tank prover full to the brim with fresh water and float off any light debris.
19. Open the discharge valve and drain the tank prover in its normal manner (using pump / gravity flow, etc.).
20. If the tank prover has a lower neck and scale, which enables the bottom level to vary slowly draw the water level down to the zero position on the scale.
 - When at or near the zero mark on the scale, close the tank prover discharge valve.
 - Read the water level at the bottom of the meniscus on the lower neck scale.
21. If the tank prover has a fixed zero and weir, slowly draw the water level down to just above the zero mark and the weir.
 - Close the discharge valve.
 - Draw down the water level using the side outlet at the weir position on the tank prover lower neck until the flow stops.
22. If the tank prover has a “dry” bottom, slowly draw the water down to near zero in a manner similar to that of a test measure.
 - Allow the tank prover to drain in the prescribed manner, for the prescribed time, after cessation of main flow.
 - Close the discharge valve.
23. Fill all field standard test measures being used with fresh water.
24. Verify that all field standard test measures being used are level when full.
25. Determine the temperature of each test measure by the immersion method.
26. Read the water level on each test measure scale at the bottom of the meniscus.
27. Drain each test measure into the tank prover in the prescribed manner.
28. Stop each test measure draining upon reaching the time prescribed on its Report of Calibration, ready to be re-filled again as required.
29. Refill the test measures and repeat Steps 23 through 28 as required.
30. When the last test measure is empty the water level in the prover tank should have reached the target volume.
31. Determine the exact water level in the tank prover at the bottom of the meniscus on the upper neck scale.

32. Determine the temperature of the water in the tank prover using temperature devices located in thermowells, by means of the immersion method or while draining. If taken while draining, read the prover temperature for this run after reaching stability and within the first third of the measured volume.
33. This completes one calibration run.
34. Repeat steps 18 through 33 until two consecutive runs agree within 0.020%
35. Evaluate these results to see how close the average calibrated volume is to the target volume.
36. Make an appropriate adjustment of the upper and/or lower scale(s) to make the scale reading(s) agree with the average calibrated volume.
37. After adjustment of the scale(s), repeat steps 18 through 33.
38. Determine the calibrated volume of the tank prover for this third run.
 - If this run does not confirm the target volume within 0.010%, the calibration shall be continued.
 - If this run does confirm the target volume within 0.010%, then seal the neck scale(s) in place.
39. This completes the calibration.
40. If the scales are not moveable, steps 36, 37, and 38 do not apply and a notation is put onto the Calibration Certificate Package showing the difference between the “target” volume and the actual Base Prover Volume determined.

Refer to 6.1.14 for calculation and repeatability requirements. Even when all the repeatability criteria have been met, the calibration may be continued if in the opinion of all the interested parties, doubt about the integrity of the final calibrated volume has been introduced.

8.0 Troubleshooting Calibration Problems

Repeatability problems between prover calibration runs can be symptomatic of many things. All problems in prover calibrations manifest themselves in the inability to obtain repeatable results between consecutive calibration passes or in extreme cases the inability to even complete a successful calibration pass.

The following discussion is provided and may be helpful in troubleshooting your system. Also, for information on calculating uncertainties in waterdraw calibrations, see Appendix A.

8.1 EVALUATION OF CALIBRATION RESULTS

Repeatability between the results of consecutive calibrated prover volumes (CPV) at standard conditions is calculated from the formula:

$$R = \left[\frac{(MaxCPV - MinCPV)}{(MinCPV)} \right] \times 100$$

Acceptable repeatability is defined as within a range of 0.020% for consecutive calibration volumes. For additional information refer to the API *MPMS*, Chapter 12, Section 2, Part 4, “Calculation of Base Prover Volumes by the Waterdraw Method”, for complete details on the determination of repeatability.

Whenever a newly determined prover volume shows a change of more than 0.02% from its previous volume, an attempt should be made to determine the underlying root cause that would account for this change of volume. While a change of prover volume may be considered significant, there is no limitation placed on the extent to which this new volume is permitted to change from the previous volume. It is not incorrect or unacceptable to report and use a new prover volume, which has changed from the previous prover volume by an amount in excess of 0.02%.

However, the cause of such a volume change does need to be fully investigated and documented. The opinion of the operators, technicians and witnesses may all be sought in making determinations at this stage of the calibration. There are many factors that can influence and cause a volume change in a prover. Some typical causes of volume changes in provers can be replacement of detector switches; mechanical repairs to the prover; physical damage to prover; wax deposits within the calibrated section of the prover; loss of coating inside the prover; and many other reasons. Sometimes it is more or less impossible to determine the root cause for a prover volume change.

These reasons and any other relevant factors should all be investigated and a judgement made on the validity of the volume change. If this volume change is significant to the loss/gain operating results, or places an unacceptable bias into the system, then additional prover calibrations may be required to either confirm, or reject, that this change of volume is valid. In some cases, the

prover may need to be re-calibrated more frequently than its normal predetermined schedule, until the stability of its volume can be demonstrated.

8.2 LEAKS

Any water leakage, whether internal or external, between the inlet of the calibrated section of the prover up to and into the test measures, will result in errors in the calibration. This will be indicated by poor repeatability with an over-statement or under-statement of the prover volume.

The most obvious sources of external leaks are from the gaskets in the connections joining flexible hoses. However, there are many other possible leak sources such as, pumps, valves, including solenoid valves, flanges, screwed connections or test measures. All need to be checked for leaks. Loss of water due to splashing during the top filling of test measures is considered an external leak. Severe cases will affect the final prover volume.

Internal leaks can be much more difficult to diagnose and detect. The most obvious source of water leakage is around the sphere displacer. However, other sources of internal leakage can be through sphere interchanges and four-way valves. Leakage may be consistent or inconsistent and can contribute to increasing or decreasing the determined prover volume. Leakage will often manifest itself in an inability to obtain repeatable results.

If enough information has been gathered from calibration run data, there may emerge a clear pattern of bias in volumes obtained between slow and fast runs. This can be an indication of leakage (e.g. displacer, four-way valve, sphere interchange assembly, drain valve etc.). It should be noted that most other deficiencies also show up as a lack of repeatability, and therefore leakage is only one of many areas to be considered when trouble-shooting calibration problems.

8.3 PROVER DETECTOR SWITCHES

Prover detector switches can have acceptable repeatability for regular meter proving, and yet have unacceptable repeatability for waterdraw calibrations. This can be due to the stringent requirements of repeatability in waterdraw calibrations. Prover detector switches should be dismantled, cleaned, inspected, repaired and re-assembled as part of the normal preparation of the prover for calibration. Defective parts shall be replaced. In some cases it may be desirable and/or advantageous to completely replace the entire detector switch. This reduces the possibility of detector switch failures, which would require an unscheduled waterdraw calibration.

On unidirectional provers, replacement or adjustment of a detector switch between scheduled calibrations carries a high risk of base volume change. Therefore, a waterdraw calibration is needed upon changing, or even adjusting a single detector switch on a unidirectional prover.

On bi-directional provers, the “out” (e.g., “left to right”) volume of the prover often does not coincide with the “back” (e.g., “right to left”) volume, and there is no requirement that these two volumes should agree. This volume difference may be caused by having one detector switch plunger inserted slightly deeper than the other one. What is important, is that the detector actuation point be symmetrical about the centerline for any given detector. If it is not, then replacement of a detector switch between calibrations may result in a significant change of round trip volume.

8.4 SPHERE INTERCHANGES

Prover sphere interchanges can cause problems by leakage or improper operation. A ram type interchange can leak through damaged seat or seals. A launching carriage type interchange may not seal properly, due to the accumulation of trash, cuts or abrasions in the elastomeric seals, or distortion to the interchange seal or seat. Incorrectly set torque switches, limit switches, hydraulic switches, low hydraulic pressure or the inability to launch the displacer due to back flow problems, may all cause the improper operation of a prover interchange.

During each calibration run, a positive seal should be confirmed at the interchange. Visual verification of sealing is preferred, and should not be based solely on leak detecting devices, such as pressure gauges, switches or automatic systems, unless no other leak detection option is available. In the case of losing hydraulic pressure on the interchange plunger, the use of pressure gauges may be required to determine when it is necessary to apply additional pressure. Always try to get visual verification of sealing.

8.5 FOUR-WAY VALVES

Leakage of the seals or improper seating of a plug valve can both cause problems. Leaking seals may be caused by trash accumulation, or by cuts, nicks or abrasions to the elastomer in the valve seal or seat, or by physical distortion of the valve. Improper plug seating of a four way valve may be a function of improperly set torque switches, limit switches, hydraulic switches, low hydraulic pressure, or incorrect manual or automatic operation.

All four-way valves shall be of a double block-and-bleed construction. Positive valve sealing should be confirmed during each calibration run. Various leak detection devices are often installed on four-way valves, and leak free operation shall be verified for each calibration pass of the displacer. Visual (e.g., by manually venting) verification of the valve sealing during calibration runs is preferred.

8.6 DISPLACERS

Prover displacers generally consist of two types:

- Spheres made of elastomers (elastomeric type spheres)
- Pistons with seals made of elastomers (elastomeric type seals)

8.6.1 Elastomeric Sphere Displacers

Elastomeric sphere displacers shall have been checked for condition, prior to the calibration, as part of the preparation of the prover. At this same time verification of the sphere size around two axes, namely, “north-south” and “east-west”, shall verify its eccentricity or “out-of-roundness”. Out-of-round sphere displacers can cause poor repeatability between waterdraw results because of the way the changing surfaces of the sphere contact the detector switches and the walls of the calibrated section of the prover. Verification of the amount of over-inflation of the sphere shall also have been determined at this time, and the sphere inflation increased or decreased as necessary. Depending upon condition, usage, service, dimensions, and age of the sphere, a decision is made whether to use the old sphere or to replace it with a new sphere for the calibration. If air is left in the interior of a sphere displacer during the inflation process, then the sphere size can vary during operation because higher pressures inside the prover will compress the air reducing the size of the sphere.

Excessive over-inflation normally has no significant effect on the calibration results since a prover sphere that is sealing at 3% oversize, will not show any additional benefits by inflating it to 6% oversize. In some cases, however, depending upon the durometer (hardness) of the sphere material, a large over-inflation of a prover sphere may actually cause it to leak. However, it will certainly increase the wear to the sphere and may cause it to move with an irregular (shuddering) motion through the pipe at the lower flow rates used in the calibration. Shuddering movements of a sphere during a calibration run, particularly as it approaches a detector switch can significantly affect the detector actuation point and therefore impact the repeatability of the results obtained. Using a thin coating of a water-resistant lubricant on the sphere can often help ensure a smoother motion.

Under-inflation however, will always result in leakage around the sphere, and will therefore result in poor sphere movement and irregular detector switch actuation. This can cause inaccuracies in the calibrated volume and may result in poor repeatability.

Repeatability problems require all aspects of sphere inflation to be considered. As a general rule, the larger the size of the prover, the larger the percent oversize required to ensure sphere displacer sealing.

For example, a sphere inflation of 3% oversize may seal well in a 12 in. prover, whereas a 3% sphere in a 30 in. prover may leak. It is quite possible that the 30 in. prover will require a higher oversize sphere inflation to seal effectively.

Varying the flow rate between calibration runs is the prescribed method for detecting leakage around the sphere. In the case of a leaking displacer, a repeatable rate of leakage can usually be obtained at a fixed flow rate. Changing the flow rate of the water can produce a different rate of leakage. Changing the flow rate, by as much as 50%, can make any sphere leakage problem more apparent and easy to detect.

During the calibration pass it may be necessary to stop a displacer during a calibration run. This may be due to the sizes of test measures being used, their filling sequence, or their filling and draining times. If it is necessary to stop the sphere displacer then every effort should be made to not halt it within any bend in the calibrated section of the prover, as this can provide another possible leak path. Stopping the sphere at flange joints, fittings, or physical imperfections in the measuring section can also result in leak paths being created. If halting the sphere becomes necessary or unavoidable, then a well thought-out plan should be made to

calculate and define the stopping location of the displacer in the pipe, so as to avoid the creation of any possible leak paths. This stopping area for the displacer can be determined by the planning of the test measure filling and draining order.

8.6.2 Piston Type Displacers

Piston type displacers can have two deficiencies apparent upon inspection: physical damage to the piston itself, and elastomeric seals that are torn, worn, broken or missing. All of these deficiencies should have been corrected prior to the calibration.

Piston displacers can experience leakage past the seals just as with a sphere displacer. It is important that special attention is given to cleanliness of piston type displacers before efforts to waterdraw begin. Hydrocarbons can become trapped between the piston seals. This can result in a difference in friction between the front seal cup and the rear seal cup and also between the top and bottom of the rear seal cup. On provers with piston displacers the front seal activates the detector while the rear seal is driving the movement of the piston. Differences in friction, especially between the top and bottom of the rear seal cup, can result in an uneven shuddering movement of barbell style pistons. Experience shows that after several runs of the piston are made, the hydrocarbon trapped between the seals is displaced with water and the movement of the piston smoothes out. Making additional runs to displace hydrocarbons out of the piston is a big time waster and the resulting lack of repeatability has resulted in unnecessary detector switch inspections and adjustments. In addition, corrosion can sometimes cause bypass leaks through the body of the piston.

Captive displacer type pistons are often specialized devices and the manufacturer may have to be consulted regarding particular problems with piston leakage. With some types of provers, checking the integrity of the seals of the piston displacer may require a special test to indicate seal failure. Some piston displacers have valves contained within the body of the piston, which may be subject to leakage. Any leakage will cause error in the waterdraw results. For these specialized type piston displacers, consultation with the manufacturer may be required regarding the special tests necessary for checking internal valve and seal integrity.

8.7 DRAINS AND VENTS

Because air and vapor are compressible, their presence in the system during the calibration may be a contributing cause to poor repeatability. Vent valves are used to remove all air or vapor present in the system before and after calibration runs. Vent valves shall be visually inspected between passes to insure there is no leakage.

Drain valves shall be visually inspected between passes to insure there is no leakage. If visual indication is not possible, the valves shall be isolated and/or blinded. If vents and drains are being considered for waterdraw connections, their location should ensure that all the water used in the calibration will be circulated through the entire proving system. This is necessary to maintain constant temperature in the calibration water.

8.8 TEMPERATURE AND PRESSURE

All pressure and temperature indicators to be used in the calibration shall have certificates of calibration traceable to an approved National Metrology Institute (eg. NIST). All temperature and pressure indicators to be used in the calibration shall be verified on site against calibrated or certified devices, or have their own calibration certificates.

Temperature shall be stabilized prior to calibration, and shall be maintained as stable as possible throughout the calibration process. Changes in ambient conditions may have a significant influence on the calibration of above ground non-insulated provers. For example, variations in cloud coverage, rain, snow or sleet showers, direct or indirect sun, winds, etc. may significantly impact the ambient temperature, causing changes in the piping temperatures, piping dimensions and most importantly the circulating water temperature. These temperature changes can cause the water temperature to increase or decrease continually during the calibration runs, and make it difficult or even impossible to obtain repeatable results.

When difficulty is being experienced in achieving temperature stability, a possible way to remedy this includes one of the following procedures:

- Covering the prover with a tarpaulin
- Waiting until nightfall
- Erecting a covering shelter or enclosure

Continuous and uninterrupted circulation of the water from the waterdraw unit through the prover has been found to be the most effective method available for maintaining a stabilization of the water temperature. The importance of temperature stabilization in prover calibration cannot be over emphasized.

Variations in pressure are normal during a waterdraw calibration pass, but valves should be opened and closed in a smooth manner and sudden surges should be avoided. Pressure is dependent upon the output and mechanical state of the water transfer pump. A low-pressure centrifugal pump is recommended. Pressure and flow rates are dependent upon each other, and shall be stable during the calibration pass.

8.9 PUMPS, HOSES AND CONNECTIONS

Air in the prover can sometimes be explained by examining the suction side of the circulation pump and its piping. Suction pressures below atmospheric pressure can draw air into the pump suction through leaks in the pump seals, glands or connections.

Oversized or high-pressure pumps, when restricted, can produce excessive spray patterns into a test measure. This can result in external splashing over the sides of the test measure neck, with corresponding errors in volume measurement.

Hoses that expand or collapse during calibration can cause poor repeatability of waterdraw results. Hoses that are lying on gravel, sand or loose dirt can sometimes hide leaks. Under these conditions it is often necessary to examine each connection joint very closely to discover if any leakage is occurring.

8.10 DETECTOR SWITCHES, SOLENOIDS AND LOGIC CIRCUITS

Erratic actuation of a solenoid valve will result in poor repeatability or inaccurate volumes. A slow or sticking solenoid valve can also produce inaccurate results. Contact bounce or mechanical malfunction is often the cause of erratic solenoid operation. The design pressure of a solenoid valve must equal or exceed the operating pressure of the system. Follow the manufacturer's instructions and ensure that the correct logic circuit is used for the type of prover being calibrated, otherwise, results may be unpredictable. Be absolutely sure that the solenoid valves are connected to the intended detectors.

8.11 FIELD STANDARD TEST MEASURES

Field standard test measures used in prover calibrations are the core equipment required in the determination of the prover volume. They can contribute to errors in the waterdraw calibration results in many ways, including the following:

- Test measure out of level at the time the scale is read
- Overflowing a test measure which results in unmeasured water
- Improper draining procedure of the test measure
- Test measure full of aerated water resulting in incorrect scale reading
- Presence of hydrocarbons in the water affecting drain-down characteristics and scale readings
- Broken seals indicating possible scale movement
- Damage (e.g., dents, bulges) to test measure
- Incorrect NIST Report of Calibration for the test measure(s) being used
- Leaking drain valve or sight glass on the test measure(s)
- Foreign material inside the test measure(s) (e.g., coatings, residues and objects)
- Scale reading errors (e.g., incorrect interpolation, eyes not perpendicular to scale, human error)
- Cleanliness of sight glass causing an ill-defined meniscus

8.12 PIPING AND MANIFOLDS

Piping and manifolds connected to the prover may contain relief valves, drain valves, vent valves, fittings and flanges, all of which need to be visually inspected to ensure that no leakage is occurring downstream of the displacer. If visual verification is not possible they shall be isolated prior to the start of the calibration.

High points and dead legs in the piping and manifolds must be free of air and/or hydrocarbons prior to any calibration pass taking place. Air and/or hydrocarbons in the system during calibration, whether upstream or downstream of the displacer, and even in "dead" legs, can cause volume errors. Hydrocarbons not removed from the proving system will affect the water quality and density/temperature relationship. These hydrocarbons may also be introduced into the test measures and alter their delivered volumes by coating the inside walls. This would affect the apparent volume of the prover.

Excessive lengths of pipe and large piping manifolds exposed to temperature extremes may result in poor repeatability between calibration runs and/or change significantly the certified volume of the prover. All unnecessary piping shall be isolated from the prover to reduce these unknown conditions, particularly if causing temperature instability, which could adversely affect the cali-

bration results. A rise in water temperature in any piping adjacent to the waterdraw connection leading to the test measures, may overstate the volume of the prover, while a temperature drop may understate the volume. Refer to Appendix B, Effects of Temperature Changes on the Interface Inventory, for further information.

8.13 WATER QUALITY

The thermal expansion rate of water containing hydrocarbons is undeterminable. Hydrocarbons will also change the surface-tension characteristics of the water. This can affect the drain-down characteristics of the test measure and result in different volumes being retained (clingage) in the test measure after draining. Hydrocarbons in the calibration water can cause two problems. They can give the water a milky appearance (emulsion), and/or cause gas bubbles to form inside the test measure and sight glass. Rising bubbles will cause the meniscus level in the sight glass to decrease continuously, making accurate scale readings difficult and of questionable accuracy. Aerated or dirty water can also cause similar problems. Fresh, clean, de-aerated water is essential for a good calibration. Water that is salty or heavily contaminated (e.g., mud, silt, sediment, bacteria, and solids) should be avoided. In the case of any type of water contamination it is advisable to drain the prover and waterdraw unit and refill with clean stable water prior to attempting a calibration.

8.14 AIR AND ENTRAINED GAS

Air or gas entrained in the calibration water can cause non-repeatability and inaccuracy in calibration passes. Gas can cause the water to froth or foam making accurate scale readings in test measures very difficult. Air that has been entrained into water will come out in a rapid decompression as it leaves the prover. This causes the volume of the water to decrease as tiny bubbles escape resulting in unstable and inaccurate scale readings.

While the water itself might be of good quality, there must be sufficient breakout time for entrained gas to be released. If too small a reservoir of water in the waterdraw unit is being used there may not be enough time for the gas to be released.

As the displacer moves there will be a variation in friction causing a corresponding variation in pressure. This can have a strong effect on the amount of water displaced because of the compressibility of gas.

8.15 PROVER CONDITIONS AND COATINGS

Poor prover construction can cause difficulties in obtaining a repeatable calibration. If visual inspection of the prover sphere shows cuts, abrasions, gouges, etc., it may be indicative of sub-standard prover construction. For example, a non-coated prover calibrated section can produce rust, corrosion, deposits and excessive friction. Small diameter internal pipe fittings and pipe welds that are not ground smooth can cause sphere damage, sphere leakage, or both.

Coating a prover calibrated section will provide a hard, smooth, long-lasting finish that will allow the sphere displacer to move more smoothly, lessen friction, lower the required operating pressure and reduce wear. There are two common types of prover coatings, which are in regular use to coat the calibrated section of provers. These are recognized as the air-dried epoxy and the baked phenolic finishes. Each type of coating has its preferred use depending upon the prover service and type of products to be measured. Discussion with any or all of the prover, sphere, and coating manufacturers is recommended, before selecting the type of coating to be used for a particular prover service.

The best type of coating to be applied is usually determined by the prover service and products. Both types of coatings are generally hard wearing and can give reasonable service life. However, over time and use, all coatings are susceptible to failure. Wear, flaking, cracking, peeling, and detaching are all conditions that can occur over time to the coating, which will give rise to increasing prover volumes, wear, and a greater probability of leakage past the prover sphere.

Loss of internal pipe coating, particularly the flaking type of loss rather than simply wearing down of the coating, can often create leak paths and result in increased prover volumes. Larger sphere inflation is often necessary to compensate for leakage due to coating loss. However, care should be taken when over inflating the ball to achieve a repeatable waterdraw. While over inflation may produce repeatable results, it is also a certain indication that a non-desirable problem exists which will likely lead to mis-measurement in the future.

Non coated provers can also cause excessive wear, damage and leakage to a sphere displacer, and are not generally recommended except where special circumstances dictate its application.

Improper storage of tank provers may result in rust, scale, or other debris on the inside of the prover. During the calibration, this may come loose, changing the volume of the prover between runs.

APPENDIX A (Informative) UNCERTAINTIES IN METER PROVER CALIBRATIONS

There are several aspects of any measurement that describes how closely it represents reality. The terms below are given to assist the reader and are not meant to take the place of precise definitions given in any current or updated issues of API *MPMS* Chapter 13, “Statistical Methods of Evaluating Meter Proving Data.”

Accuracy: The ability to indicate values closely approximating the true value of the measured variable.

Confidence Interval or Range of Uncertainty: The range or interval within which the true value is expected to lie with a stated degree of confidence. For example, a device with an accuracy of two percent would have an uncertainty range of $\pm 2\%$. When expressed as a quantity rather than as a percent it would normally be expressed as a confidence interval. For example a volume throughput measurement of 100,000 units of volume with a flow meter that has an accuracy of 0.25% might be said to have an uncertainty range of $\pm 0.25\%$ and a confidence interval of ± 250 units of volume.

Error: The difference between true and observed values.

Error, Random: One that varies from the true value in an unpredictable manner under effectively identical conditions.

Error, Systematic: One in which the observed values differ from the true value by a constant amount or varies in a predictable manner, either of which results in a bias.

Repeatability: A measure of the agreement between the results of successive measurements of the same variable carried out by the same method, with the same instrument, at the same location, and within a short period of time.

Reproducibility: A measure of the agreement between the results of measurements of the same variable; where, individual measurements are carried out by the same methods, with the same type of instrument, but by different observers, at different locations, and after a long period of time, or where only some of the factors listed are different.

The total uncertainty of an instrument consists of both systematic uncertainty and random uncertainty. Experience and comparison to other systems determine the systematic uncertainty, whereas random uncertainty must be determined by experiment on a specific piece of equipment.

Systematic uncertainty in the use of a meter prover stems from its calibrated volume. While the calibration incurred both systematic and random uncertainties, the systematic uncertainty of the prover during operation must include the random uncertainties of the calibration. Random uncertainties during the metering operations will vary depending upon operating conditions (e.g. flow condition, rate changes, fluid property changes etc.) as well as the condition and suitability of the meter being proved. Though these random uncertainties, under a particular set of operating conditions, add to the uncertainty of the metering system, they are not within the scope of this document.

A.1 Uncertainty Impact—Prover Detector Switches

This discussion determines the change in linear position of a sphere displacer relative to the mechanical actuation of a prover detector switch. As the mechanical tolerance of the detector switch varies, so does the calibrated volume of the prover. Because of this relationship, the accuracy of a prover calibrated volume can be determined from the actuation tolerance of the sphere detector switch.

A.1.1 RELATIONSHIP OF SPHERE DISPLACER TRAVEL TO UPWARD MOVEMENT OF DETECTOR SWITCH PROBE

- Detector Switch offset = δI (represents the amount of upward travel of detector probe to gate point)
- Sphere traverse for the offset above = δX (represents the amount of forward travel of the sphere from the first point of contact with the detector probe to the upward point where the detector switch gates)

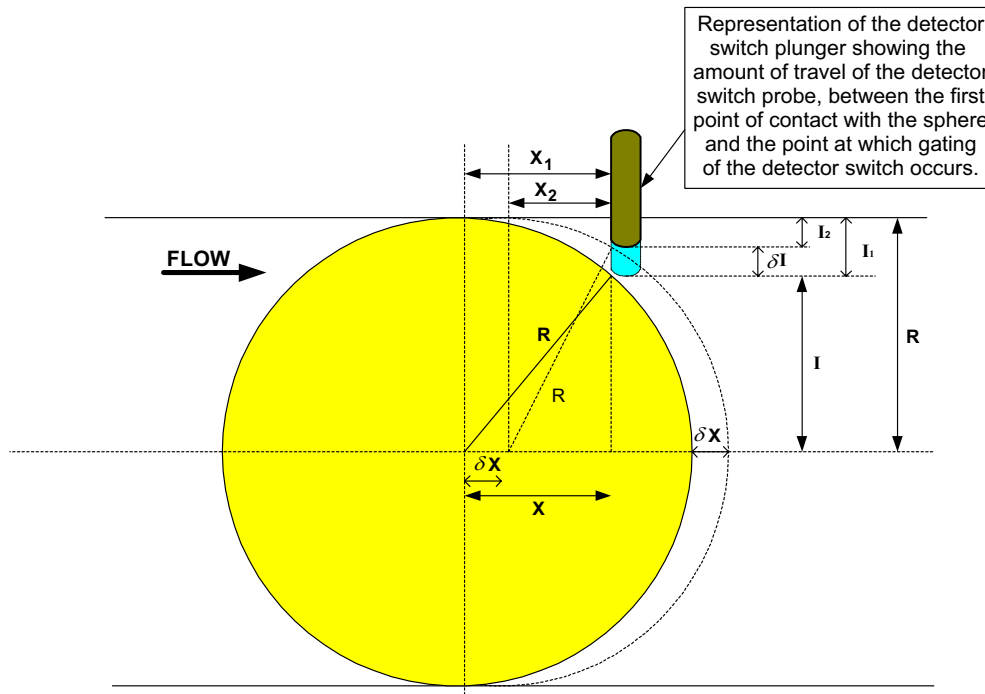

Figure—A.1—Uncertainty Analysis: Detector Switch Actuation Point with Respect to the Forward Movement of the Prover Sphere

- From Figure A.1 the relationship between δI and δX is shown as follows:

$$R^2 = X^2 + I^2 \text{ (Pythagorean theorem)}$$

$$X^2 = R^2 - I^2$$

- Differentiating X with respect to I :

$$2X \cdot \delta X = 2I \cdot \delta I$$

$$\delta X = (I/X) \cdot \delta I$$

$$= \sqrt{R^2 - X^2} \cdot (\delta I/X)$$

- Assume detector switch is located at:

$$X = 0.25 \cdot R$$

- Using the equation above calculate δX :

$$\delta X = \sqrt{R^2 - 0.25^2 R^2} \cdot (\delta I/X)$$

$$= \sqrt{0.9375 \cdot R^2} \cdot (\delta I)/(0.25 \cdot R)$$

$$= (0.968 \cdot R \cdot \delta I)/(0.25 \cdot R)$$

$$\delta X = 3.87 \cdot \delta I$$

Equation 1

A.1.2 DETECTOR SWITCH UNCERTAINTY ASSOCIATED WITH VARIATION IN SPHERE AND PIPE DIAMETER

- This section discusses uncertainty in the diameter of the prover pipe and the sphere displacer
- δR is defined as either the variation in prover pipe or displacer sphere radius
- δI is defined as the variation in the upward detector switch movement, with respect to the variation in pipe or sphere radius.
- Relationship between δR and δI from the previous drawing, and if $X = 0.25 \cdot R$, then:

$$I^2 = R^2 - X^2$$

- Differentiating I with respect to R :

$$2I \cdot \delta I = 2R \cdot \delta R$$

$$\delta I = R/I \cdot \delta R$$

$$\delta I = \frac{R}{\sqrt{R^2 - \left(\frac{R}{4}\right)^2}} \cdot \delta R$$

$$\delta I = \delta R \text{ (approximately)}$$

Equation 2

A.1.3 COMBINED DETECTOR SWITCH UNCERTAINTY

- Combined uncertainty equals the combination of Equations 1 and 2

$$\delta X_T = [(\delta X)^2 + (\delta I)^2]^{1/2}$$

$$\delta X_T = [(3.87 \cdot \delta I)^2 + (\delta I)^2]^{1/2}$$

$$\delta X_T = [(3.87 \cdot \delta R)^2 + (\delta R)^2]^{1/2}$$

$$\delta X_T = [(14.98 * \delta R^2) + (\delta R)^2]^{1/2}$$

$$\delta X_T = 4 * \delta R \text{ (approximately)}$$

- Variations in radius can be from 2 mm to 5 mm due to the combined effect of sphere variation, its location and the variation in the pipe prover radius.
- Hence total variations in δX_T can be from 8 mm to as much as 20 mm for the two boundary conditions.
- For the above variations, the % uncertainty of the prover volume for various diameters can be computed. Results are given below:

Table A-1—Detector Switch, Sphere and Pipe Diameter Uncertainty

Prover Diameter	δX Minimum	δX Maximum	% Uncertainty	Prover Volume
(nominal) Inches	δX_T 8 mm	δX_T 20 mm	% Uncertainty Prover Volume	Volume in Gallons
	Uncertainty in Gallons	Uncertainty in Gallons		
6	0.04	0.09	0.008 – 0.018	500
12	0.16	0.36	0.016 – 0.036	1000
24	0.64	1.44	0.032 – 0.072	2000
36	1.44	3.24	0.036 – 0.081	4000

A.1.4 CONCLUSIONS ON DETECTOR SWITCH, AND SPHERE AND PIPE UNCERTAINTY

- Percent Uncertainty depends on actual prover capacity. Hence if a 36 in. diameter prover has a minimum capacity of 10,000 gallons for example, the % uncertainty will be significantly less at the lower end of scale.
- Above calculations are based on the combined effect of prover diameter, detector switch location and sphere diameter.
- The uncertainty is based on total error concept and systematic component is already factored into the estimates.

A.1.5 CALCULATION OF SPHERE POSITION WITH UPWARD MOVEMENT OF DETECTOR PROBE

The following equation can be used to determine the change in linear position of the sphere relative to the mechanical operation of the detector switch. As the mechanical tolerance of the detector switch varies so does the prover volume.

From the drawing figure A.1: $\delta I = (I_1 - I_2)$ and $\delta X = (X_1 - X_2)$

For the sphere position of first contact with the detector switch:

$$R^2 = X_1^2 + I^2,$$

and therefore:

$$X_1^2 = R^2 - I^2$$

$$X_1 = \sqrt{R^2 - I^2}$$

$$X_1 = \sqrt{R^2 - (R - I_1)^2}$$

$$X_1 = \sqrt{(D \times I_1) - I_1^2}$$

Similarly for the sphere position of switch contact at the point of actuation:

$$X_2 = \sqrt{(D \times I_2) - I_2^2}$$

$$\delta X = (X_1 - X_2) = \sqrt{(D \times I_1) - I_1^2} - \sqrt{(D \times I_2) - I_2^2}$$

where

D = the diameter of the sphere or the I.D. of the pipe prover

As an example consider the following data:

If

$$D = 13.25 \text{ in. (the pipe diameter} = 14 \text{ in. and the wall thickness} = 0.375 \text{ in.)}$$

$$I_1 = 0.1875 \text{ in. (the insertion depth of the detector probe)}$$

$$I_2 = 0.1625 \text{ in. (the depth of the detector probe at the point of actuation)}$$

$$\delta I = 0.0250 \text{ in.}$$

Then

$$\delta X = \sqrt{(13.25 \times 0.1875) - 0.1875^2} - \sqrt{(13.25 \times 0.1625) - 0.1625^2}$$

$$\delta X = 0.107 \text{ in.}$$

(The forward movement of the sphere is equal to approximately 4 times the upward movement of the detector switch).

A.2 Uncertainty Impact—Field Standard Test Measure

Table A-2—Uncertainty Due to Test Measure Combination

Prover Volume (Gallons)	500 Gallon Test Measure (0.010%)	200 Gallon Test Measure (0.008%)	100 Gallon Test Measure (0.006%)	50 Gallon Test Measure (0.005%)	Combined Uncertainty (Volume%)
550	1			1	0.009
		2	1	1	0.004
		1	3	1	0.003
			5	1	0.002
				11	0.002
1050	2			1	0.007
	1	5		1	0.005
		5			0.003
		2	6	1	0.003
			10	1	0.002
1950	3		4	1	0.004
	2		9	1	0.004
			19	1	0.001
3950	7		4	1	0.003
			39		0.001
		10	19	1	0.001

Table A-2 is an example of combined uncertainties using various combinations of test measures. Actual statistical values would vary depending upon the uncertainty for each test measure as indicated on its Report of Calibration. Usually, the test measure combination has little statistical impact upon the overall uncertainty in a waterdraw calibration.

In the event that the larger test measures have higher uncertainties than some of the intermediate size test measures, other operational aspects, such as reducing the number of fills, should be considered. For instance, reducing the number of fills can make it easier to devote more care and attention to each scale reading and may thus reduce exposure to reading errors. Generally, a maximum of ten test measure fillings per pass is recommended.

Whenever they are available the use of larger test measures is preferred and encouraged. For example, it can be seen that with a prover volume of 3,950 gallons, having a 500-gallon test measure available will considerably lessen the mechanical work required. The filling of 11 test measures (i.e., 500 gallons x 7 fills, 100 gallons x 4 fills and 50 gallons x 1 fill) will considerably simplify the calibration process. Whereas the alternative of filling 40 test measures (i.e., 100 gallons x 39 fills and 50 gallons x 1 fill), with all the additional mechanical work of filling and emptying, together with level verification, scale reading, and temperature taking.

A.3 Uncertainty Impact—Number of Calibration Runs

API *MPMS* Chapter 13.2, “Statistical Methods of Evaluating Meter Proving Data,” can be used to estimate the standard deviation and uncertainty of meter prover calibration procedures. A range limit of 0.020% between high and low runs is normally used to prescribe prover calibration acceptance requirements. The estimated standard deviations and ranges of uncertainty (\pm % range) at the 95% confidence level, of the average of three to five calibration runs that agree within a range of 0.020%, are given in Table A-3. It illustrates the marginal reduction of uncertainty obtained by making more than three runs. Three or more runs are necessary because the uncertainty of making only two runs is too high, due to happenstance.

Table A-3—Estimated Uncertainty of Prover Calibration Runs (at the 95% confidence level)

Run No. 1	Run No. 2	Run No. 3	Run No. 4	Run No. 5	Deviations	Mean of Runs
10000	10000.5	10000			Each run minus the mean equals its deviation	10000.1667
10000	10001	10000				10000.3333
10000	10001.5	10000				10000.5
10000	10002	10000				10000.6667
10000	10000.5	10000	10000.5		Each run minus the mean equals its deviation	10000.25
10000	10001	10000	10001			10000.5
10000	10001.5	10000	10001.5			10000.75
10000	10002	10000	10002			10001
10000	10000.5	10000	10000.5	10000	Each run minus the mean equals its deviation	10000.2
10000	10001	10000	10001	10000		10000.4
10000	10001.5	10000	10001.5	10000		10000.6
10000	10002	10000	10002	10000		10000.8
Number of Runs N	Degrees of Freedom n – 1	Sum of Squared Deviations	Estimated Standard Deviation	Estimated STD DEV X 2	2 x STD DEV / Mean	Range of Uncertainty +/-%
3	2	0.167	0.289	0.577	0.00005773	0.006
3	2	0.667	0.577	1.155	0.00011547	0.012
3	2	1.500	0.866	1.732	0.00017320	0.017
3	2	2.667	1.155	2.309	0.00023092	0.023
4	3	0.250	0.289	0.577	0.00005773	0.006
4	3	1.000	0.577	1.155	0.00011546	0.012
4	3	2.250	0.866	1.732	0.00017319	0.017
4	3	4.000	1.155	2.309	0.00023092	0.023
5	4	0.300	0.274	0.548	0.00005477	0.005
5	4	1.200	0.548	1.095	0.00010954	0.011
5	4	2.700	0.822	1.643	0.00016431	0.016
5	4	4.800	1.095	2.191	0.00021907	0.022

A.4 Overall Uncertainties

The following is an example only, in context of a waterdraw calibration using assumed values in Table A-4:

To determine the overall uncertainty for a given prover:

- Combine the “prover detector impact” and the “field standard test measure impact” for a predicted uncertainty
- Combine the “number of runs impact” and the “field standard test measure impact” for a calculated uncertainty after the waterdraw calibration has been performed.

Table A-4—Assumed Values from A.1, A.2 and A.3 for illustration purposes only

Prover Volume in U.S. Gallons	Prover Detector Impact Volume% Minimum	Prover Detector Impact Volume% Maximum	Test Measure Impact Volume% Minimum	Test Measure Impact Volume% Maximum	Number of Runs (3) Impact Volume% Minimum	Number of Runs (3) Impact Volume% Maximum
550	0.008	0.018	0.002	0.009	0.006	0.023
1050	0.016	0.036	0.002	0.007	0.006	0.023
1950	0.032	0.072	0.001	0.004	0.006	0.023
3950	0.036	0.081	0.001	0.003	0.006	0.023

Assuming a prover volume of 1950 gallons, and assuming maximum prover detector and test measure impacts, the predicted overall uncertainty could be calculated as follows:

$$\delta V(\%) = \frac{\sqrt{\left(\frac{0.072}{100} \times 1950\right)^2 + \left(\frac{0.004}{100} \times 1950\right)^2}}{1950} \times 100$$

$$\delta V(\%) = 0.072\% \text{ approximately}$$

Assuming a prover volume of 1950 gallons, and assuming maximum number of runs and test measure impacts, the overall uncertainty could be calculated after the waterdraw calibration as follows:

$$\delta V(\%) = \frac{\sqrt{\left(\frac{0.023}{100} \times 1950\right)^2 + \left(\frac{0.004}{100} \times 1950\right)^2}}{1950} \times 100$$

$$\delta V(\%) = 0.023\% \text{ approximately}$$

It is assumed in the above discussion that three consecutive calibration runs were made and that their repeatability was all within a range of 0.020%.

Application of Uncertainty Estimates:

If during a waterdraw calibration a repeatability of 0.020% cannot be obtained, then it is an indication that the uncertainty associated with that waterdraw is very high and probably exceeding the repeatability criteria. An estimate of uncertainty can be made using procedures presented.

If after the uncertainty is estimated and it is established to be 0.072% as indicated in the previous example, then it is an indication that the prover detector switch and sphere diameter uncertainty are the major factors of why it is not possible to get repeatability during the waterdraw calibration. This will provide a basis for replacing the sphere or the detector switches or both.

CAUTION: If after it is established that the uncertainty is as large as 0.072% as illustrated above, and during the waterdraw calibration a repeatability of 0.020% was achieved, it is coincidental and probably cannot be reproduced.

Uncertainty analysis provides a powerful tool to determine if and when replacement of spheres and or detector switches would be required. Without this concept, replacement of detector switches and spheres could only be made by trial and error. As a general rule detector switches and sphere displacers are the biggest contributors to overall uncertainty and thus they control repeatability.

If in the final analysis, both the detector switches and the sphere is determined to be in good condition, then it is an indication that the prover bore diameter is the contributor and this would then call for a major overhaul.

Uncertainty analysis is a key process that should be undertaken to complement the waterdraw procedure.

It is assumed in the above discussion that all of the guidelines of this standard were followed in performing the waterdraw calibration.

It is not within the scope of this document to fully treat all of the aspects of the subject of theoretical uncertainties in prover calibrations. However, other items that were considered for the discussion of evaluating the overall uncertainty of a waterdraw calibrated volume of a meter prover included:

- Water density effects (CTDW values)...
- Temperature effects (CTSM, CTSP, CTDW)...
- Pressure effects (CPSP, CPLP)...
- Prover steel compositional effects (CTSP, CPSP)...
- Prover dimensional variation effects (CPSP)...

The above items were seen to be insignificant if the parameters outlined below were followed:

- Fresh water used
- Temperatures accurate to $\pm 0.1^{\circ}\text{F}$ ($\pm 0.05^{\circ}\text{C}$)
- Pressures accurate to ± 1 psi
- Type of steel properly identified for both prover and test measures
- Prover made of specially selected pipe that meets all normal-manufacturing tolerances
- Temperature stability was maintained throughout the system during each pass/run

**APPENDIX B
(Normative)
EFFECTS OF TEMPERATURE CHANGES ON THE INTERFACE INVENTORY**

A waterdraw calibration pass of a prover is the displacement of water from the first detector switch action to the second detector switch action and collecting the water displaced into field standard test measures. However, in practical terms, there is a volume of water contained in the prover and hoses from the second detector switch to the inlet of the test measures. This volume of water, called the interface inventory, is defined as the volume of water that lies between the second detector on any calibration pass of the prover and the entrance to the test measures. It can be as much as 50% of the volume of water contained between the two detector switches. Therefore, it is apparent that not all, but a significant amount of the water displaced during the calibration pass, and collected in the test measures, is made up of water from this inventory. The effects of temperature changes in the interface inventory, which occurs between the actuation of the first detector switch until the actuation of the second detector switch, for any given pass, is evaluated in the following discussion.

Table B-1—Temperature Difference in Interface Inventory

Impact of Inventory on Prover Repeatability:%	±0.5°F	±1.0°F	±2.0°F	±3.0°F
	V_i (% of V_P)	V_i (% of V_P)	V_i (% of V_P)	V_i (% of V_P)
±0.001%	13.2	6.6	3.3	2.3
±0.002%	26.4	13.2	6.6	4.6
±0.003%	39.6	19.8	9.9	6.9
±0.004%	> 50.0	26.4	13.2	9.2
±0.005%		33.0	16.5	11.5
±0.010%			33.0	23.0
±0.015%			49.5	34.5
±0.020%				46.0

Assumptions:

It is assumed that the inventory variations impact the prover directly on a one on one basis.

Hence the uncertainty in inventory (in volume units) for a given impact on prover repeatability can be used to determine maximum inventory volume.

The inventory volume however may not exceed 50% of the prover volume. This is the upper limit set for the analysis.

Example: (V_i = Volume of Interface Inventory, V_P = Volume of Prover)

Let the temperature variation in inventory.... = 2.0° F

Inventory volume uncertainty in pipe volume... = 0.03% of V_i

Let the contribution of this to prover.... = 0.005%

Then:

$$0.03\% \cdot V_i = 0.005\% \cdot V_P$$

$$\text{or } V_i = 16.5\% \cdot V_P \text{ etc.}$$

The following table has been prepared based on the following assumptions:

- a prover temperature (T_p) of 80°F
- a test measure temperature (T_{tm}) of 80°F
- a beginning interface inventory temperature (T_1) of 80°F
- an ending interface inventory temperature (T_2) that varies from 76°F to 84°F.

Table B-2

Temp. (T1) Temp. (Ttm) Temp. (Tp) Deg. F	Temp. (T2) Ending Interface Deg. F	Temp. Change (T1 – T2) Deg. F	(Vi/Vp) 10% Impact on R% +/-	(Vi/Vp) 20% Impact on R% +/-	(Vi/Vp) 30% Impact on R% +/-	(Vi/Vp) 40% Impact on R% +/-	(Vi/Vp) 50% Impact on R% +/-	(CTDW) Correction To Calculate Impact
80.0	76.0	4.0	0.006%	0.012%	0.017%	0.023%	0.029%	1.000583
80.0	76.5	3.5	0.005%	0.010%	0.015%	0.021%	0.026%	1.000513
80.0	77.0	3.0	0.004%	0.009%	0.013%	0.018%	0.022%	1.000442
80.0	77.5	2.5	0.004%	0.007%	0.011%	0.015%	0.018%	1.000370
80.0	78.0	2.0	0.003%	0.006%	0.009%	0.012%	0.015%	1.000298
80.0	78.5	1.5	0.002%	0.004%	0.007%	0.009%	0.011%	1.000224
80.0	79.0	1.0	0.002%	0.003%	0.005%	0.006%	0.008%	1.000150
80.0	79.5	0.5	0.001%	0.002%	0.002%	0.003%	0.004%	1.000075
80.0	80.0	0.0	0.000%	0.000%	0.000%	0.000%	0.000%	1.000000
80.0	80.5	-0.5	-0.001%	-0.002%	-0.002%	-0.003%	-0.004%	0.999924
80.0	81.0	-1.0	-0.002%	-0.003%	-0.005%	-0.006%	-0.008%	0.999847
80.0	81.5	-1.5	-0.002%	-0.005%	-0.007%	-0.009%	-0.012%	0.999769
80.0	82.0	-2.0	-0.003%	-0.006%	-0.009%	-0.012%	-0.015%	0.999691
80.0	82.5	-2.5	-0.004%	-0.008%	-0.012%	-0.016%	-0.019%	0.999612
80.0	83.0	-3.0	-0.005%	-0.009%	-0.014%	-0.019%	-0.023%	0.999532
80.0	83.5	-3.5	-0.005%	-0.011%	-0.016%	-0.022%	-0.027%	0.999452
80.0	84.0	-4.0	-0.006%	-0.013%	-0.019%	-0.025%	-0.031%	0.999371

Explanation:

Waterdraw theory is developed from the following basic assumption: The mass of water displaced from the prover between the first detector to the second detector during a calibration pass is equal to the mass of water received by the test measures.

$$\text{Mass of water displaced (prover)} = \text{Mass of water received (test measures)}$$

However, the amount of water received by the test measures is largely influenced by changes in the mass of the water contained in the interface inventory, from the beginning to the end of a calibration pass. Unstable water temperatures can cause a significant change in interface inventory.

$$\begin{array}{ccccccc} \text{Mass of water} & & \text{Mass of water in} & & \text{Mass of water in} & & \text{Mass of water} \\ \text{displaced between} & + & \text{interface inventory at} & - & \text{interface inventory} & = & \text{received by the} \\ \text{detectors in prover} & & \text{beginning of pass} & & \text{at end of pass} & & \text{test measure(s)} \end{array}$$

Treating only the temperature of the water, assuming only one test measure filling for sake of discussion, and ignoring all other aspects (e.g. compressibility of water, steel temperature, pressure on steel) the above relationship can be described as follows:

$$MASS_p + MASS_1 - MASS_2 = MASS_m$$

$$(V_p \times RHO_p) + (V_i \times RHO_1) - (V_i \times RHO_2) = (V_m \times RHO_m)$$

$$(V_p \times RHO_p) = (V_m \times RHO_m) - (V_i \times RHO_1) + (V_i \times RHO_2)$$

$$V_p = \frac{(V_m(RHO_m)) - (V_i(RHO_1)) + (V_i(RHO_2))}{(RHO_p)}$$

$$V_p = (V_m \times CTDW) - (V_i \times CTDW_1) + (V_i \times CTDW_2)$$

Explanation:

$$V_p = \left(V_m \frac{RHO_m}{RHO_p} \right) - \left(V_i \frac{RHO_1}{RHO_p} \right) + \left(V_i \frac{RHO_2}{RHO_p} \right)$$

where

$$RHO_m / RHO_p = CTDW$$

$$RHO_1 / RHO_p = CTDW_1$$

$$RHO_2 / RHO_p = CTDW_2$$

$$\begin{aligned} \text{Inventory Impact} &= [V_p - (V_m \times CTDW)] \\ &= (V_i \times CTDW_2) - (V_i \times CTDW_1) \end{aligned}$$

where

MASS _p	=	Mass of water between detectors at start of calibration pass
MASS ₁	=	Mass of interface inventory at start of calibration pass
MASS ₂	=	Mass of interface inventory at end of calibration pass
MASS _m	=	Mass of water received by the test measure
V _p	=	Volume of water between detectors at start of calibration pass
V _i	=	Volume of water in interface inventory
V _m	=	Volume of water received by the test measure
RHO _p	=	Density of water at prover temperature at start of calibration pass
RHO ₁	=	Density of water in interface inventory at start of calibration pass
RHO ₂	=	Density of water in interface inventory at end of calibration pass
RHO _m	=	Density of water received by the test measure
CTDW	=	RHO _m / RHO _p (Reference API MPMS Chapter 11 for CTDW)
CTDW ₁	=	RHO ₁ / RHO _p (Reference API MPMS Chapter 11 for CTDW)
CTDW ₂	=	RHO ₂ / RHO _p (Reference API MPMS Chapter 11 for CTDW)
T _p	=	Temperature of water in prover at start of calibration pass
T ₁	=	Temperature of water in interface at start of calibration pass
T ₂	=	Temperature of water in interface at end of calibration pass
T _m	=	Temperature of water received by the test measure

Example of Interface Inventory Calculation:

$$T_p = 80^\circ\text{F}$$

$$T_1 = 80^\circ\text{F}$$

$$T_2 = 82^\circ\text{F}$$

$$T_{tm} = 82^\circ\text{F}$$

$$V_m = 500 \text{ gallons}$$

$$V_i = 200 \text{ gallons (40\% of Nominal } V_p)$$

$$\text{CTDW} = 0.999691$$

$$\text{CTDW}_1 = 1.000000$$

$$\text{CTDW}_2 = 0.99969$$

$$V_p = (500 \times 0.999691) - (200 \times 1.000000) + (200 \times 0.999691)$$

$$= (499.8455) - (200.0000) + (199.9382) \text{ (rounded to 4 decimal places)}$$

$$= 499.7837 \text{ gallons}$$

$$\text{Inventory Impact} = (499.7837) - (500 \times 0.999691)$$

$$= -0.0618 \text{ gallons}$$

$$= -(0.0618 / (499.8455) \times (100))$$

$$= -0.012\%$$

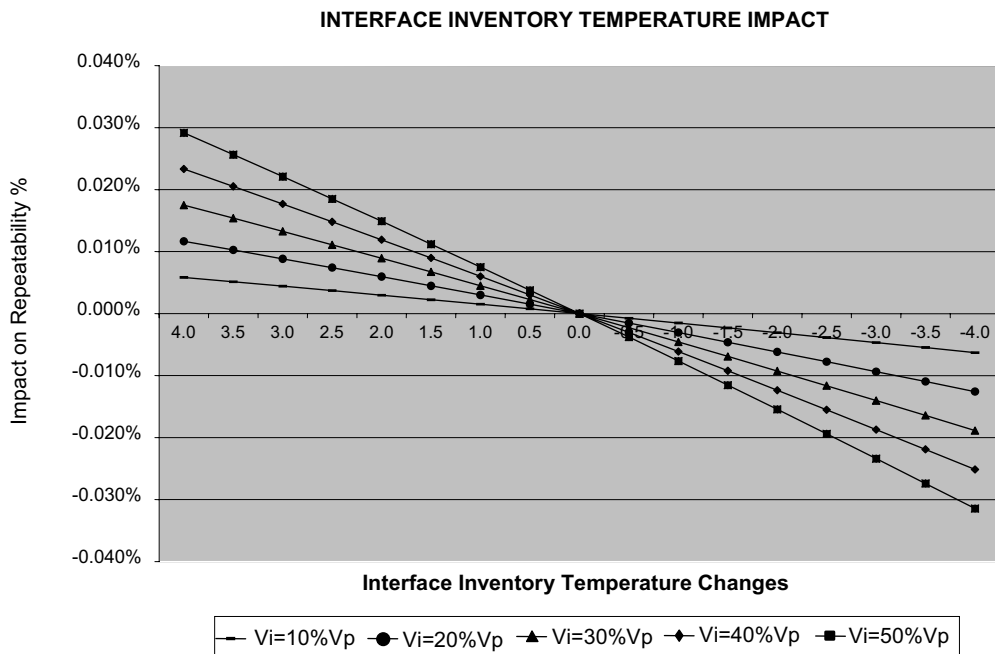

**APPENDIX C
(INFORMATIVE)
EXAMPLES OF WATERDRAW DATA SHEETS**

C-1 Displacement Type Unidirectional Prover with Free Displacer

C-2 Displacement Type Bi-directional Prover with Free Displacer

C-3 Displacement Type Unidirectional Prover with Captive Displacer

C-4 Atmospheric Tank Prover

C-5 Prover & Test Measure Data Sheet

C-6 Waterdraw Calibration Run / Pass Data Sheet

Note: The above referenced example forms are for illustration purposes only. Actual forms used may differ from the above. The example forms are meant to convey the essential information that is necessary to calculate the prover volume.

Example C-1—Displacement Type Unidirectional Prover with Free Displacer

PROVER & TEST MEASURE DATA SHEET

Owner: API Oil Company Date: July 26, 2002

Prover Location: San Antonio, Texas Report No. 1001

Designation: API MPMS Chapter 4.9.1

Prover Manufacturer: WD Manufacturing Prover Type: Unidirectional Pipe

Serial Number: 1111 Grade of Steel: Mild Carbon Steel

Wall Thickness: 0.432 Prover I.D.: 5.761

Coefficient of Cubical Expansion per degree F/C 0.0000186 per degree F

Coefficient of Square Expansion per degree F/C N/A

Coefficient of Linear Expansion per degree F/C N/A

Base Temperature (F/C) for the Prover: 60 degrees F Modulus of Elasticity: 30,000,000 per psi

Previous Volume: 2.15140 bbls Date of Last Calibration: September 5, 1997

Displacer Type: Polyurethane (yellow) Sphere Displacer Size: C = 18 1/2" = 102.2%

Detector Switches: "A", "B", and "C" Number of Volumes: Three (3)

Identification of detector switches used on this calibration: A: Seal No. aaaa and C: Seal No. cccc.

Location of detector switches used on this calibration: From quick closure, 1st and 3rd detectors.

Remarks: Multiple Volume Prover, volume between detectors "A" and "C" determined

Test Measure Reference Number	NIST Seal Number	Base Temperature °F/°C	Grade of Steel	Cubical Coefficient Per degree F/C	Test Measure Nominal Gallons/m ³	Test Measure Base Volume in ³ /ml
1	5050	60	Stainless	0.0000265	50	11551.50
2	3030	60	Stainless	0.0000265	30	6931.27
3	5555	60	Stainless	0.0000265	5	1155.23
4						
5						
6						
7						
8						

Waterdraw Operator _____ Witness _____

Witness _____ Witness _____

Witness _____ Witness _____

Witness _____ Witness _____

Example C-1—Displacement Type Unidirectional Prover with Free Displacer

WATERDRAW CALIBRATION RUN / PASS DATA SHEET				Sheet No: <u>1</u> of <u>3</u>	
Calibration Date: July 26, 2002			Report Number: 1001		
Time: 8:30 AM			Prover Serial No. 1111		
Weather: Cool and Cloudy			Volume Identification: Detectors A and C		
Pass No.	1	Prover Pressure:	39 psig	S/N of Pressure Gauge:	pppppp
Run No.	1	Prover Temperature:	86.0 deg. F	S/N of Thermometer:	qqqqqq
Direction:	OUT	Detector Temperature:	N/A	S/N of Thermometer:	N/A
Flow Rate:	50 GPM	Thermometer for Test Measure...		S/N of Thermometer:	nnnnnn
Atmospheric Tank...		Upper Scale Reading:	N/A	Lower Scale Reading:	N/A
Fill No.	Test Measure Reference No.	Base Volume cu.in./cu.cm.	Scale Reading Plus (+)	Scale Reading Minus (-)	Water Temp. DegF or degC
1	2	6931.27		4.0	86.4
2	3	1155.23	0.0		86.5
3	1	11551.50	69.0		86.4
4	3	1155.23	11.5		86.5
5					
6					
7					
8					
9					
10					
11					
12					
13					
14					
15					
16					
17					
18					
19					
20					
21					
22					
23					
24					
25					

Remarks:

Witnesses: (Signature and Company)

Example C-1—Displacement Type Unidirectional Prover with Free Displacer

WATERDRAW CALIBRATION RUN / PASS DATA SHEET

Sheet No: 2 of 3

Calibration Date: July 26, 2002		Report Number: 1001			
Time: 8:40 AM		Prover Serial No. 1111			
Weather: Cool and Cloudy		Volume Identification: Detectors A and C			
Pass No. 2	Prover Pressure: 39 psig	S/N of Pressure Gauge: pppppp			
Run No. 2	Prover Temperature: 86.5 deg. F	S/N of Thermometer: qqqqqq			
Direction: OUT	Detector Temperature: N/A	S/N of Thermometer: N/A			
Flow Rate: 25 GPM	Thermometer for Test Measure...	S/N of Thermometer: nnnnnn			
Atmospheric Tank...	Upper Scale Reading: N/A	Lower Scale Reading: N/A			
Fill No.	Test Measure Reference No.	Base Volume cu.in./cu.cm.	Scale Reading Plus (+)	Scale Reading Minus (-)	Water Temp. degF or degC
1	2	6931.27		5.0	87.0
2	3	1155.23		0.5	87.0
3	1	11551.50	70.0		87.0
4	3	1155.23	12.5		87.0
5					
6					
7					
8					
9					
10					
11					
12					
13					
14					
15					
16					
17					
18					
19					
20					
21					
22					
23					
24					
25					

Remarks:

Witnesses: (Signature and Company)

Example C-1—Displacement Type Unidirectional Prover with Free Displacer

WATERDRAW CALIBRATION RUN / PASS DATA SHEET

Sheet No: 3 of 3

Calibration Date: July 26, 2002			Report Number: 1001		
Time: 8:50 AM			Prover Serial No. 1111		
Weather: Cool and Cloudy			Volume Identification: Detectors A and C		
Pass No.	3	Prover Pressure:	39 psig	S/N of Pressure Gauge:	pppppp
Run No.	3	Prover Temperature:	87.5 deg. F	S/N of Thermometer:	qqqqqq
Direction:	OUT	Detector Temperature:	N/A	S/N of Thermometer:	N/A
Flow Rate:	50 GPM	Thermometer for Test Measure...		S/N of Thermometer:	nnnnnn
Atmospheric Tank...		Upper Scale Reading:	N/A	Lower Scale Reading:	N/A
Fill No.	Test Measure Reference No.	Base Volume cu.in./cu.cm.	Scale Reading Plus (+)	Scale Reading Minus (-)	Water Temp. degF or degC
1	2	6931.27		6.0	87.7
2	3	1155.23	0.0		87.8
3	1	11551.50	72.0		87.9
4	3	1155.23	11.0		87.9
5					
6					
7					
8					
9					
10					
11					
12					
13					
14					
15					
16					
17					
18					
19					
20					
21					
22					
23					
24					
25					

Remarks:

Witnesses: (Signature and Company)

Example C-2—Displacement Type Bi-directional Prover with Free Displacer

PROVER & TEST MEASURE DATA SHEET

Owner: API Oil Company Date: March 26, 2001

Prover Location: San Antonio, Texas Report No. 1002

Designation: API MPMS Chapter 4.9.1

Prover Manufacturer: WD Manufacturing Prover Type: Bi-directional Pipe

Serial Number: 2222 Grade of Steel: 316 Stainless Steel

Wall Thickness: 0.365 Prover I.D.: 10.020

Coefficient of Cubical Expansion per degree F/C 0.0000265 per degree F

Coefficient of Square Expansion per degree F/C N/A

Coefficient of Linear Expansion per degree F/C N/A

Base Temperature (F/C) for the Prover: 60 degrees F Modulus of Elasticity: 28,000,000 per psi

Previous Volume: 4.36999 bbls Date of Last Calibration: Sept. 2, 1999

Displacer Type: Piston with Neoprene Cups Displacer Size: C = 32 1/8" = 102.1%

Detector Switches: "A" and "B". Number of Volumes: One (1)

Identification of detector switches used on this calibration: A: Seal No. aaaa and B: Seal No. bbbb.

Location of detector switches used on this calibration: From quick closure, 1st and 2nd detectors.

Remarks: "B" detector is on the right side of prover where the blind flange is located.

Test Measure Reference Number	NIST Seal Number	Base Temperature °F/°C	Grade of Steel	Cubical Coefficient Per degree F/C	Test Measure Nominal Gallons/m ³	Test Measure Base Volume in ³ /ml
1	5050	60	Stainless	0.0000265	50	11547.80
2	2121	60	Stainless	0.0000265	21	4845.87
3						
4						
5						
6						
7						
8						

Waterdraw Operator _____ Witness _____

Witness _____ Witness _____

Witness _____ Witness _____

Witness _____ Witness _____

Example C-2—Displacement Type Bi-directional Prover with Free Displacer

WATERDRAW CALIBRATION RUN / PASS DATA SHEETSheet No: 1 of 6

Calibration Date: March 26, 2001			Report Number: 1002		
Time: 8:30 AM			Prover Serial No. 2222		
Weather: Cool and Cloudy			Volume Identification: Detectors A and B		
Pass No.	3	Prover Pressure:	40 psig	S/N of Pressure Gauge:	pppppp
Run No.	RT-I	Prover Temperature:	55.8 deg. F	S/N of Thermometer:	qqqqqq
Direction:	R to L	Detector Temperature:	N/A	S/N of Thermometer:	N/A
Flow Rate:	20 GPM	Thermometer for Test Measure...		S/N of Thermometer:	nnnnnn
Atmospheric Tank...		Upper Scale Reading:	N/A	Lower Scale Reading:	N/A
Fill No.	Test Measure Reference No.	Base Volume cu.in./cu.cm.	Scale Reading Plus (+)	Scale Reading Minus (-)	Water Temp. degF or degC
1	2	4845.87	2.0		55.6
2	1	11547.8		48.0	55.6
3	2	4845.87		10.5	55.6
4					
5					
6					
7					
8					
9					
10					
11					
12					
13					
14					
15					
16					
17					
18					
19					
20					
21					
22					
23					
24					
25					

Remarks:

Witnesses: (Signature and Company)

Example C-2—Displacement Type Bi-directional Prover with Free Displacer

WATERDRAW CALIBRATION RUN / PASS DATA SHEET

Sheet No: 2 of 6

Calibration Date: March 26, 2001		Report Number: 1002			
Time: 8:40 AM		Prover Serial No. 2222			
Weather: Cool and Cloudy		Volume Identification: Detectors A and B			
Pass No. 4	Prover Pressure: 40 psig	S/N of Pressure Gauge: pppppp			
Run No. RT-I	Prover Temperature: 56.1 deg. F	S/N of Thermometer: qqqqqq			
Direction: L to R	Detector Temperature: N/A	S/N of Thermometer: N/A			
Flow Rate: 20 GPM	Thermometer for Test Measure...	S/N of Thermometer: nnnnnn			
Atmospheric Tank...	Upper Scale Reading: N/A	Lower Scale Reading: N/A			
Fill No.	Test Measure Reference No.	Base Volume cu.in./cu.cm.	Scale Reading Plus (+)	Scale Reading Minus (-)	Water Temp. degF or degC
1	2	4845.87	2.0		55.8
2	1	11547.8		11.0	55.9
3	2	4845.87		20.0	55.6
4					
5					
6					
7					
8					
9					
10					
11					
12					
13					
14					
15					
16					
17					
18					
19					
20					
21					
22					
23					
24					
25					

Remarks:

Witnesses: (Signature and Company)

Example C-2—Displacement Type Bi-directional Prover with Free Displacer

WATERDRAW CALIBRATION RUN / PASS DATA SHEET

Sheet No: 3 of 6

Calibration Date: March 26, 2001		Report Number: 1002			
Time: 8:50 AM		Prover Serial No. 2222			
Weather: Cool and Cloudy		Volume Identification: Detectors A and B			
Pass No. 5	Prover Pressure: 40 psig	S/N of Pressure Gauge: pppppp			
Run No. RT-II	Prover Temperature: 56.2 deg. F	S/N of Thermometer: qqqqqq			
Direction: R to L	Detector Temperature: N/A	S/N of Thermometer: N/A			
Flow Rate: 40 GPM	Thermometer for Test Measure...	S/N of Thermometer: nnnnnn			
Atmospheric Tank...	Upper Scale Reading: N/A	Lower Scale Reading: N/A			
Fill No.	Test Measure Reference No.	Base Volume cu.in./cu.cm.	Scale Reading Plus (+)	Scale Reading Minus (-)	Water Temp. degF or degC
1	2	4845.87	2.0		56.2
2	1	11547.8		46.0	56.2
3	2	4845.87		10.0	55.6
4					
5					
6					
7					
8					
9					
10					
11					
12					
13					
14					
15					
16					
17					
18					
19					
20					
21					
22					
23					
24					
25					

Remarks:

Witnesses: (Signature and Company)

Example C-2—Displacement Type Bi-directional Prover with Free Displacer

WATERDRAW CALIBRATION RUN / PASS DATA SHEET

Sheet No: 4 of 6

Calibration Date: March 26, 2001		Report Number: 1002			
Time: 9:00 AM		Prover Serial No. 2222			
Weather: Cool and Cloudy		Volume Identification: Detectors A and B			
Pass No. 6	Prover Pressure: 40 psig	S/N of Pressure Gauge: pppppp			
Run No. RT-II	Prover Temperature: 56.2 deg. F	S/N of Thermometer: qqqqqq			
Direction: L to R	Detector Temperature: N/A	S/N of Thermometer: N/A			
Flow Rate: 40 GPM	Thermometer for Test Measure...	S/N of Thermometer: nnnnnn			
Atmospheric Tank...	Upper Scale Reading: N/A	Lower Scale Reading: N/A			
Fill No.	Test Measure Reference No.	Base Volume cu.in./cu.cm.	Scale Reading Plus (+)	Scale Reading Minus (-)	Water Temp. degF or degC
1	2	4845.87	1.0		56.2
2	1	11547.8		19.0	56.2
3	2	4845.87		9.5	55.6
4					
5					
6					
7					
8					
9					
10					
11					
12					
13					
14					
15					
16					
17					
18					
19					
20					
21					
22					
23					
24					
25					

Remarks:

Witnesses: (Signature and Company)

Example C-2—Displacement Type Bi-directional Prover with Free Displacer

WATERDRAW CALIBRATION RUN / PASS DATA SHEETSheet No: 5 of 6

Calibration Date: March 26, 2001			Report Number: 1002		
Time: 9:10 AM			Prover Serial No. 2222		
Weather: Cool and Cloudy			Volume Identification: Detectors A and B		
Pass No.	7	Prover Pressure:	40 psig	S/N of Pressure Gauge:	pppppp
Run No.	RT-III	Prover Temperature:	56.4 deg. F	S/N of Thermometer:	qqqqqq
Direction:	R to L	Detector Temperature:	N/A	S/N of Thermometer:	N/A
Flow Rate:	20 GPM	Thermometer for Test Measure...		S/N of Thermometer:	nnnnnn
Atmospheric Tank...		Upper Scale Reading:	N/A	Lower Scale Reading:	N/A
Fill No.	Test Measure Reference No.	Base Volume cu.in./cu.cm.	Scale Reading Plus (+)	Scale Reading Minus (-)	Water Temp. degF or degC
1	2	4845.87	3.5		56.2
2	1	11547.8		50.0	56.5
3	2	4845.87		7.5	55.6
4					
5					
6					
7					
8					
9					
10					
11					
12					
13					
14					
15					
16					
17					
18					
19					
20					
21					
22					
23					
24					
25					

Remarks:

Witnesses: (Signature and Company)

Example C-2—Displacement Type Bi-directional Prover with Free Displacer

WATERDRAW CALIBRATION RUN / PASS DATA SHEET Sheet No: 6 of 6

Calibration Date: March 26, 2001			Report Number: 1002		
Time: 9:20 AM			Prover Serial No. 2222		
Weather: Cool and Cloudy			Volume Identification: Detectors A and B		
Pass No. 8	Prover Pressure: 40 psig		S/N of Pressure Gauge: pppppp		
Run No. RT-III	Prover Temperature: 56.5 deg. F		S/N of Thermometer: qqqqqq		
Direction: L to R	Detector Temperature: N/A		S/N of Thermometer: N/A		
Flow Rate: 20 GPM	Thermometer for Test Measure...		S/N of Thermometer: nnnnnn		
Atmospheric Tank...	Upper Scale Reading: N/A		Lower Scale Reading: N/A		
Fill No.	Test Measure Reference No.	Base Volume cu.in./cu.cm.	Scale Reading Plus (+)	Scale Reading Minus (-)	Water Temp. degF or degC
1	2	4845.87		8.0	56.3
2	1	11547.8		19.0	56.6
3	2	4845.87		1.5	55.6
4					
5					
6					
7					
8					
9					
10					
11					
12					
13					
14					
15					
16					
17					
18					
19					
20					
21					
22					
23					
24					
25					

Remarks:

Witnesses: (Signature and Company)

Example C-3—Displacement Type Unidirectional Prover with Captive Displacer

PROVER & TEST MEASURE DATA SHEET

Owner: API Oil Company Date: March 26, 2001

Prover Location: San Antonio, Texas Report No. 1003

Designation: API MPMS Chapter 4.9.1

Prover Manufacturer: WD Manufacturing Prover Type: Displacement / Captive Displacer

Serial Number: 3333 Grade of Steel: 17-4PH Stainless Steel

Wall Thickness: 0.875 Prover I.D.: 12.250

Coefficient of Cubical Expansion per degree F/C N/A

Coefficient of Square Expansion per degree F/C 0.0000120 per degrees F

Coefficient of Linear Expansion per degree F/C 0.0000008 per degree F (Special Alloy Rod)

Base Temperature (F/C) for the Prover: 60 degrees F Modulus of Elasticity: 28,500,000 per psi

Previous Volume: New Prover Date of Last Calibration: New Prover

Displacer Type: Piston with Viton Seals Displacer Size: C = 39¼" = 102%

Detector Switches: "A" and "B" Number of Volumes: One (1)

Identification of detector switches used on this calibration: A: Seal No. aaaa and B: Seal No. bbbb.

Location of detector switches used on this calibration: 1st and 2nd detectors.

Remarks: _____ This calibration is for the upstream volume.

Test Measure Reference Number	NIST Seal Number	Base Temperature °F/°C	Grade of Steel	Cubical Coefficient Per degree F/C	Test Measure Nominal Gallons/m ³	Test Measure Base Volume in ³ /ml
1	1515	60	Stainless	0.0000265	15	3463.22
2						
3						
4						
5						
6						
7						
8						

Waterdraw Operator _____ Witness _____

Witness _____ Witness _____

Witness _____ Witness _____

Witness _____ Witness _____

Example C-3—Displacement Type Unidirectional Prover with Captive Displacer

WATERDRAW CALIBRATION RUN / PASS DATA SHEET Sheet No: 1 of 3

Calibration Date: March 26, 2001		Report Number: 1003			
Time: 8:30 AM		Prover Serial No. 3333			
Weather: Cool and Cloudy		Volume Identification: Detectors A and B			
Pass No. 1	Prover Pressure: 35 psig	S/N of Pressure Gauge: pppppp			
Run No. 1	Prover Temperature: 71.6 deg. F	S/N of Thermometer: qqqqqq			
Direction: OUT	Detector Temperature: 70.0 deg. F	S/N of Thermometer: dddddd			
Flow Rate: 20 GPM	Thermometer for Test Measure...	S/N of Thermometer: nnnnnn			
Atmospheric Tank...	Upper Scale Reading: N/A	Lower Scale Reading: N/A			
Fill No.	Test Measure Reference No.	Base Volume cu.in./cu.cm.	Scale Reading Plus (+)	Scale Reading Minus (-)	Water Temp. degF or degC
1	1	3463.22	17.3		71.2
2					
3					
4					
5					
6					
7					
8					
9					
10					
11					
12					
13					
14					
15					
16					
17					
18					
19					
20					
21					
22					
23					
24					
25					

Remarks:

Witnesses: (Signature and Company)

Example C-3—Displacement Type Unidirectional Prover with Captive Displacer

WATERDRAW CALIBRATION RUN / PASS DATA SHEET						Sheet No: 2 of 3
Calibration Date: March 26, 2001			Report Number: 1003			
Time: 8:40 AM			Prover Serial No. 3333			
Weather: Cool and Cloudy			Volume Identification: Detectors A and B			
Pass No. 2	Prover Pressure: 35 psig		S/N of Pressure Gauge: pppppp			
Run No. 2	Prover Temperature: 72.2 deg. F		S/N of Thermometer: qqqqqq			
Direction: OUT	Detector Temperature: 70.0 deg. F		S/N of Thermometer: dddddd			
Flow Rate: 10 GPM	Thermometer for Test Measure...		S/N of Thermometer: nnnnnn			
Atmospheric Tank...	Upper Scale Reading: N/A		Lower Scale Reading: N/A			
Fill No.	Test Measure Reference No.	Base Volume cu.in./cu.cm.	Scale Reading Plus (+)	Scale Reading Minus (-)	Water Temp. degF or degC	
1	1	3463.22	17.5		71.8	
2						
3						
4						
5						
6						
7						
8						
9						
10						
11						
12						
13						
14						
15						
16						
17						
18						
19						
20						
21						
22						
23						
24						
25						

Remarks:

Witnesses: (Signature and Company)

Example C-3—Displacement Type Unidirectional Prover with Captive Displacer

WATERDRAW CALIBRATION RUN / PASS DATA SHEET Sheet No: 3 of 3

Calibration Date: March 26, 2001		Report Number: 1003			
Time: 8:50 AM		Prover Serial No. 3333			
Weather: Cool and Cloudy		Volume Identification: Detectors A and B			
Pass No. 3	Prover Pressure: 35 psig	S/N of Pressure Gauge: pppppp			
Run No. 3	Prover Temperature: 72.3 deg. F	S/N of Thermometer: qqqqqq			
Direction: OUT	Detector Temperature: 70.0 deg. F	S/N of Thermometer: dddddd			
Flow Rate: 20 GPM	Thermometer for Test Measure...	S/N of Thermometer: nnnnnn			
Atmospheric Tank...	Upper Scale Reading: N/A	Lower Scale Reading: N/A			
Fill No.	Test Measure Reference No.	Base Volume cu.in./cu.cm.	Scale Reading Plus (+)	Scale Reading Minus (-)	Water Temp. degF or degC
1	1	3463.22	17.2		71.7
2					
3					
4					
5					
6					
7					
8					
9					
10					
11					
12					
13					
14					
15					
16					
17					
18					
19					
20					
21					
22					
23					
24					
25					

Remarks:

Witnesses: (Signature and Company)

Example C-4—Atmospheric Tank Prover

PROVER & TEST MEASURE DATA SHEET

Owner: API Oil Company Date: March 26, 2001
 Prover Location: San Antonio, Texas Report No. 1004
 Designation: API MPMS Chapter 4.9.1
 Prover Manufacturer: WD Manufacturing Prover Type: Atmospheric Tank Prover
 Serial Number: 4444 Grade of Steel: Mild Carbon Steel
 Wall Thickness: 0.375in. Prover I.D.: 96 in.
 Coefficient of Cubical Expansion per degree F/C 0.0000186 per degree F
 Coefficient of Square Expansion per degree F/C N/A
 Coefficient of Linear Expansion per degree F/C N/A
 Base Temperature (F/C) for the Prover: 60 degrees F Modulus of Elasticity: 30,000,000
 Previous Volume: 1,000 gallons Date of Last Calibration: June 16, 1998
 Displacer Type: N/A Displacer Size: N/A
 Detector Switches: N/A Number of Volumes: One (1)
 Identification / Location of Detectors Used on This Calibration: N/A

Remarks: Calibrated by drawing water from tank prover into test measures

Test Measure Reference Number	NIST Seal Number	Base Temperature °F/°C	Grade of Steel	Cubical Coefficient Per degree F/C	Test Measure Nominal Gallons/m ³	Test Measure Base Volume in ³ /ml
1	5001	60	Stainless	0.0000265	500	115502.50
2	5002	60	Stainless	0.0000265	500	115506.00
3						
4						
5						
6						
7						
8						

Waterdraw Operator _____ Witness _____

Witness _____ Witness _____

Witness _____ Witness _____

Witness _____ Witness _____

Example C-4—Atmospheric Tank Prover

WATERDRAW CALIBRATION RUN / PASS DATA SHEET				Sheet No: 1 of 3	
Calibration Date: March 26, 2001		Report Number: 1004			
Time: 8:30 AM		Prover Serial No. 4444			
Weather: Cool and Cloudy		Volume Identification: 1000 gallons			
Pass No. 1	Prover Pressure: 0 psig		S/N of Pressure Gauge: N/A		
Run No. 1	Prover Temperature: 60.2 deg. F		S/N of Thermometer: qqqqqq		
Direction: Prover to TM	Detector Temperature: N/A		S/N of Thermometer: N/A		
Flow Rate: 90 GPM	Thermometer for Test Measure...		S/N of Thermometer: nnnnnn		
Atmospheric Tank...		Upper Scale Reading: 1000.0 Gallons		Lower Scale Reading: 0.0 Gallons	
Fill No.	Test Measure Reference No.	Base Volume cu.in./cu.cm.	Scale Reading Plus (+)	Scale Reading Minus (-)	Water Temp. degF or degC
1	2	115502.50		0.0	60.2
2	1	115506.00		50.0	60.2
3					
4					
5					
6					
7					
8					
9					
10					
11					
12					
13					
14					
15					
16					
17					
18					
19					
20					
21					
22					
23					
24					
25					

Remarks:

Witnesses: (Signature and Company)

Example C-4—Atmospheric Tank Prover

WATERDRAW CALIBRATION RUN / PASS DATA SHEET				Sheet No: <u>2</u> of <u>3</u>	
Calibration Date: March 26, 2001			Report Number: 1004		
Time: 9:30 AM			Prover Serial No. 4444		
Weather: Cool and Cloudy			Volume Identification: 1000 gallons		
Pass No.	2	Prover Pressure:	0 psig	S/N of Pressure Gauge: N/A	
Run No.	2	Prover Temperature:	60.4 deg. F	S/N of Thermometer: qqqqqq	
Direction:	Prover to TM	Detector Temperature:	N/A	S/N of Thermometer: N/A	
Flow Rate:	90 GPM	Thermometer for Test Measure...		S/N of Thermometer: nnnnnn	
Atmospheric Tank...		Upper Scale Reading:	1000.0 Gallons	Lower Scale Reading: 0.0 Gallons	
Fill No.	Test Measure Reference No.	Base Volume cu.in./cu.cm.	Scale Reading Plus (+)	Scale Reading Minus (-)	Water Temp. degF or degC
1	2	115502.50		0.0	60.6
2	1	115506.00		90.0	60.8
3					
4					
5		Note: Moved	upper scale UP	Approx. 0.3	
6		gallons	to adjust for the	Average of	
7		Run 1	and Run 2.		
8					
9		Note: Both	Upper and Lower	Scales sealed	
10		in	place.		
11					
12					
13					
14					
15					
16					
17					
18					
19					
20					
21					
22					
23					
24					
25					

Remarks:

Witnesses: (Signature and Company)

Example C-4—Atmospheric Tank Prover

WATERDRAW CALIBRATION RUN / PASS DATA SHEET			Sheet No: 3 of 3		
Calibration Date: March 26, 2001		Report Number: 1004			
Time: 10:30 AM		Prover Serial No. 4444			
Weather: Cool and Cloudy		Volume Identification: 1000 gallons			
Pass No. 3	Prover Pressure: 0 psig	S/N of Pressure Gauge: N/A			
Run No. 3	Prover Temperature: 60.8 deg. F	S/N of Thermometer: qqqqqq			
Direction: Prover to TM	Detector Temperature: N/A	S/N of Thermometer: N/A			
Flow Rate: 90 GPM	Thermometer for Test Measure...	S/N of Thermometer: nnnnnn			
Atmospheric Tank...		Upper Scale Reading: 1000.0 Gallons	Lower Scale Reading: 0.0 Gallons		
Fill No.	Test Measure Reference No.	Base Volume cu.in./cu.cm.	Scale Reading Plus (+)	Scale Reading Minus (-)	Water Temp. degF or degC
1	2	115502.50		0.0	61.0
2	1	115506.00	10.0		61.2
3					
4					
5					
6					
7					
8					
9					
10					
11					
12					
13					
14					
15					
16					
17					
18					
19					
20					
21					
22					
23					
24					
25					

Remarks:

Witnesses: (Signature and Company)

Example C-5—Prover & Test Measure Data Sheet

PROVER & TEST MEASURE DATA SHEET

Owner:..... Date.....

Prover Location..... Report No.....

Designation:.....

Prover Manufacturer:..... Prover Type.....

Serial Number:..... Grade of Steel.....

Wall Thickness:..... Prover I.D.:.....

Coefficient of Cubical Expansion per degree F/C

Coefficient of Square Expansion per degree F/C

Coefficient of Linear Expansion per degree F/C

Base Temperature (F/C) for the Prover..... Modulus of Elasticity.....

Previous Volume:..... Date of Last Calibration:.....

Displacer Type:..... Sphere Size:.....

Detector Switches:..... Number of Volumes:.....

Identification / Location of Detectors Used on This Calibration:.....

Remarks:.....

Test Measure Reference Number	NIST Seal Number	Base Temperature °F/°C	Grade of Steel	Cubical Coefficient Per degree F/C	Test Measure Nominal Gallons/m ³	Test Measure Base Volume in ³ /ml
1						
2						
3						
4						
5						
6						
7						
8						

Waterdraw Operator:..... Witness.....

Witness:..... Witness:.....

Witness:..... Witness:.....

Witness:..... Witness:.....

Example C-6—Waterdraw Calibration Run/Pass Data Sheet

WATERDRAW CALIBRATION RUN / PASS DATA SHEET

Sheet No: _____ of _____

Calibration Date:		Report Number:			
Time:		Prover Serial No.			
Weather:		Volume Identification:			
Pass No.	Prover Pressure:	S/N of Pressure Gauge:			
Run (R.T.) No.	Prover Temperature:	S/N of Thermometer:			
Direction:	Detector Temperature::	S/N of Thermometer:			
Flow Rate:	Thermometer for Test Measure...	S/N of Thermometer:			
Atmospheric Tank...	Upper Scale Reading:	Lower Scale Reading:			
Fill No.	Test Measure Reference No.	Base Volume cu.in./cu.cm.	Scale Reading Plus (+)	Scale Reading Minus (-)	Water Temp. degF or degC
1					
2					
3					
4					
5					
6					
7					
8					
9					
10					
11					
12					
13					
14					
15					
16					
17					
18					
19					
20					
21					
22					
23					
24					
25					

Remarks:

Witnesses: (Signature and Company)

APPENDIX D (Informative) FIELD STANDARD TEST MEASURES

Introduction

Field standard test measures are vessels fabricated to meet specific design criteria and calibrated by an appropriate national metrology institute such as the National Institute of Standards and Technology (NIST). Their primary purpose is to provide a standardized volume used for the calibration of displacement and tank provers, when calibrated by the waterdraw method. This appendix provides detailed descriptions of the use of field standard test measures not provided in the main text of this standard. Readers are referred to API *MPMS* Chapter 4, Section 7, for complete information Field Standard Test Measures, together with the NIST Handbook 105, Part 3, Specifications and Tolerances for Graduated Neck-Type Volumetric Field Standards.

Draining

For the calibration of meter provers, the draining of all field standard test measures, as described in this standard, will be as recommended when calibrated by the National Institute of Standards and Technology (NIST). Field standard test measures are constructed in two styles, either as the type that can be drained by inverting, or alternatively as the type that is drained by using a bottom drain pipe and block valve.

Test measures with a 10-gallon or lower capacity are built with a solid bottom arrangement and are inverted at a downward angle when being emptied. At the cessation of the main flow the test measure is held over at the correct angle for an additional period of time to complete the draining process. It is then returned back to an upright position ready for use. The draining time and the angle of inversion to be used are both stated on the Certificate of Calibration for the particular test measure being emptied.

Test measures with a 10-gallon or larger capacity are built with a conical bottom containing a center drain line connected with a leak-free block valve. This closed block valve represents part of the calibrated volume of the test measure. To empty this type of test measure the bottom valve is opened allowing the water to discharge until a point is reached where the main flow ceases or breaks, and becomes a trickle. Once this point is reached the test measure draining is then timed for an additional period of time before closing the bottom valve. The test measure is then ready for filling again. The draining time to be used is stated on the Certificate of Calibration for the particular test measure being emptied.

When draining both of these types of test measures the point at which the flow breaks is a clearly defined action and very easy to determine. The out-rushing flow of water will suddenly and distinctively become a trickle, almost instantly, defining the point of cessation of main flow and the starting point for the timing of the final draining period.

Ten-gallon test measures are usually the size at which the method of draining changes from inverting to the bottom drain valve method. Lifting test measures larger than 10-gallon is not recommended as practical or safe. However, there are two types of 10-gallon test measures built, which can be drained either by inverting or by means of a bottom drain valve. It is common to find either one in regular use.

Field standard test measures are calibrated with water and they are usually calibrated wet, “to deliver”, so that they may be used in a continuous manner without drying each time. Following the exact drain down time and procedure, as specified by the calibrating agency, is an essential part of the “to deliver” volume on the Report of Calibration. The words “cessation of the main flow” describe a single dramatic event that occurs abruptly and can easily be determined. No distinction is made between a trickle and a fast drip, however, the change over usually occurs from the full discharging water flow to a trickle, almost instantly, and is very easy to recognize.

The time of filling and draining of each test measure must be carefully considered when determining the filling sequence required of the available test measures to ensure smooth, and if possible, uninterrupted calibration passes. The filling time for any individual test measure can easily be determined from the test measure volume divided by the water flow rate being delivered from the circulation pump.

Table D-1, gives guidelines for the approximate total time required to drain individual test measures according to their drain size.

Table D-1—Test Measure Discharge Times Based on Volume and Drain Size

Test Measure Size in Gallons	Bottom Drain Size of Test Measure	Approximate Total Discharge Time in Minutes ¹
5	1 in.	1.0
10	1 in.	1.5
15 (See Note 2)	1 in.	1.75
15	1 ¹ / ₄ in.	1.00
15	1 ¹ / ₂ in.	1.00
20	2 in.	1.00
21 (See Note 3)	2 in.	1.00
25	2 in.	1.00
30	2 in.	1.25
50	2 in.	1.75
100	2 in.	3.00
100	3 in.	1.50
500	4 in.	3.25
500	6 in.	1.17

Note 1: NIST Calibration: All times include 30 seconds draining time.

Note 2: High Resolution Neck Test Measure

Note 3: High Resolution Neck Test Measure

Scale Readings

The water level on the scale of a field standard test measure is read with the eyes in a horizontal plane that is perpendicular to the bottom of the meniscus of the water in the sight glass. The liquid level at the bottom of the meniscus can best be observed by placing a white background behind the sight glass at the liquid level. Place a horizontal line or edge along the meniscus to better read and interpolate the cut point on the scale. Record the water level position on the neck scale that lies in a horizontal plane with the bottom of the meniscus in the sight glass. The water level scale reading of test measures is read to a maximum discrimination of 0.1 cubic inch and a minimum discrimination of ¹/₂ the value between two of the lowest value scale marks. Most operators find that it is practical to read the scale divisions on field standard test measures to the nearest ¹/₄th or ¹/₅th division.

Different techniques may be used to calibrate provers using field standard test measures. Any of the following methods can be used, however, Method 3 is the normal operating practice used today.

Method 1: Fill each test measure to its exact certified (zero) capacity, and allow the final water level to be read on completion in the last test measure filled.

Method 2: Slightly overfill each test measure and then bring the level back to the exact capacity (zero) by withdrawing some of the liquid. The liquid that is withdrawn is then released into the next test measure to be filled.

Method 3: With graduated neck test measures it is not necessary to operate at the zero level. Therefore, the test measure may be filled to any location on its scale, the liquid level read, and its certified capacity is then adjusted mathematically using a plus or minus scale reading (\pm SR). A *minus* signifies that the water level is below the certified capacity (zero mark) on the test measure scale, and a *plus* indicates that the water level is above the zero mark on the scale.

Some field standard test measures, called high-sensitivity test measures, are designed with a smaller diameter neck, which is used to achieve greater neck volume resolution in the reading of the water level meniscus. The terms “high-resolution” or “high-accuracy” also characterize this type of test measure. Neck scale readings on normal sensitivity test measures are never recorded to a value less than 0.2 in.³, whereas, high sensitivity test measures are read to a 0.1 in.³ level of resolution. As a practical matter, operators are required to read at least to a minimum discrimination of the nearest half way mark between scale lines, but can often

realistically be read to $1/4^{\text{th}}$ or $1/5^{\text{th}}$ divisions. Some typical examples of scale interpolations, not to be considered to be mandatory, are as follows:

- A 500-gallon test measure that has 25 in.³ between each scale line, half way between the lines would be 12.5 in.³, but given the width of the scale lines it is considered practical to read the scale to the nearest five cubic inches (i.e. $1/5^{\text{th}}$ division).
- A 100-gallon test measure that has five cubic inches between each scale line, half way between the lines would be 2.5 in.³, but given the width of the scale lines it is considered practical to read the scale to the nearest one cubic inch (i.e. $1/5^{\text{th}}$ division).
- A 50-gallon test measure that has two cubic inch increments is generally considered practical to read the scale to the nearest 0.5 in.³ (i.e. $1/4^{\text{th}}$ division).
- A one-gallon test measure that has 1.0 in.³ increments is generally considered practical to read the scale to the nearest 0.2 in.³ (i.e. $1/5^{\text{th}}$ division).
- A one-gallon test measure that has 0.25 in.³ scale increments (high sensitivity neck) is generally considered practical to read the scale to the nearest 0.1 in.³ (i.e. 0.1 being the maximum discrimination allowed).

Table D-2 shows the range of scale readings for interpolation between the lowest scale lines of various sizes of field standard test measures, and the typical interpolation of each lowest scale division:

Table D-2—Normal and High Sensitivity Test Measures
Interpolation of Volumes between the Lowest Scale Lines on Field Standard Test Measures

Lowest Neck Scale Increment	0.25	0.5	1	2	5	10	25
Typical Interpolation	0.1	0.1	0.2	0.5	1	2	5

Note: All Values in Cubic Inches

Test Measure Requirements and Volume Repeatability

Prior to the calibration of the prover it is necessary to ascertain the number and sizes of test measures available on the calibration unit for use in the waterdraw. The filling and sequence of rotation that can best be used for these available test measures must be determined. These requirements can be ascertained from the known or estimated volume of the prover together with the filling and draining times of the test measures.

For example, the best combination of test measures to use in a calibration pass and the acceptable volume repeatability between the passes can be determined as follows.

Consider the calibration of a 16" bi-directional meter prover:

From its calibration report, the previous round-trip volume of the prover was:

55.80754 bbls

Volume Repeatability

Previous round-trip volume = 55.80754 barrels

Previous round-trip volume = 2,343.9167 gallons

Previous round-trip volume = 541,444.753 in.³

One-way volume = 270,722.377 in.³

Allowable repeatability = 270,722.377 x 0.0002

Tolerance = 54.1445 in.³

Therefore, in this example, to demonstrate acceptable repeatability, three consecutive calibration passes, in the same direction, shall have all three volumes within 54 in.³ of each other.

Assume the waterdraw unit to be used in this calibration has the following test measures available for use: See Table D-3:

Table D-3—Example of Test Measures Available on Waterdraw Unit

Test Measure Number	NIST Seal Number	Nominal Volume In Gallons	NIST Calibrated Volume In Cubic Inches (BMV)
1	1234	100	23,095.18
2	1235	100	23,099.24
3	1236	50	11,551.6
4	1237	20	4,619.03
5	1238	10	2,305.78
6	1239	5	1,152.76
7	1240	2	459.978
8	1241	1	230.958

For our example prover, one test measure combination that will be acceptable is as follows:

- (1) 100 gallons x 5 fills = 115,475.90 in.³
 - (2) 100 gallons x 6 fills = 138,595.44 in.³
 - (3) 50 gallons x 1 fill = 11,551.60 in.³
 - (4) 20 gallons x 1 fill = 4,619.03 in.³
- Total volume from test measures= 270,241.97 in.³
- Half (½) volume from previous calibration= 270,722.376 in.³
- Difference (very approximately two gallons)= 480.406 in.³

In this example one calibration pass will require the filling of thirteen test measures, the majority of which will be the alternate filling (fill one, drain the other) of the two 100-gallon test measures. If all 13 test measures are filled to the zero marks on their scales, then there will still be a volume of 480 in.³ left in the prover to be included into the test measures to complete the calibration run.

Therefore, over the course of the filling it will be necessary to accommodate an additional 480 in.³ into the test measures by increasing the scale readings above zero. Since the scale reading on the 100-gallon test measure, will allow 250 in.³, above and below the zero mark, it will be necessary on two 100-gallon test measure fillings to take the level up above the zero mark by approximately 240 in.³. This will ensure that the last test measure filled, to finish the calibration pass, will end around the zero mark.

Alternatively, five of the 100-gallon test measures filled can each be taken up above the zero mark during the calibration pass, to around the +100 cubic inches scale reading. Either method should bring the reading of the final test measure filled, at the completion of the waterdraw calibration pass, to approximately the zero mark.

An alternative possibility would be to use an additional two-gallon test measure, which would absorb the extra 480 cubic inches. However, this would involve the use of an additional test measure when this volume can easily be absorbed during the filling sequence of the other test measures.

An alternative method of filling would be to include the three larger test measures into a filling rotation as follows:

(1) 100 gallons x 5 fills	=	115,475.90 in. ³
(2) 100 gallons x 4 fills	=	92,396.96 in. ³
(3) 50 gallons x 5 fills	=	57,758.00 in. ³
(4) 20 gallons x 1 fill	=	4,619.03 in. ³
Total volume from test measures	=	270,249.89 in. ³
Volume from previous calibration	=	270,722.376 in. ³
Difference (very approximately 2 gallons)	=	472.486 in. ³

The filling rotation of these test measures is almost the same as the previously described filling sequence, with almost the same amount remaining. This sequence of test measures may allow a longer period of time to drain each 100-gallon test measure, and make a smoother and a less rushed calibration pass. In the final analysis either sequence of filling would be satisfactory.

Once the test measures have been selected for use, it is immaterial in which order they are filled, except for the requirement of maintaining a smooth filling operation without surging the flow rate significantly, or causing the displacer to stop and start too often. After the first pass has been completed, the filling sequence should be reviewed for continuity and smoothness. It is considered prudent, but not mandatory, to keep the same sequence of test measure filling on subsequent passes.

Most operators consider it easier to begin and end in the medium or larger sized test measures. This will enable the required flow rate to be reached quickly and smoothly, and generally makes sense as long as the number of readings for each test measure remains at the optimum. In other words, one reading from a large test measure has exactly the same effect, whether it is the first test measure, the second test measure, or the last test measure filled, and the filling order is immaterial to the overall uncertainty of the total measurement. This assumes that all the test measures are filled in an operationally efficient manner with the emphasis being on the smooth transitions between test measures rather than on straining to stop the flow at an exact point on the scale each time (see Method 3 above). That is one reason it is common practice to read each scale to $1/4^{\text{th}}$ or $1/5^{\text{th}}$ divisions. When a smaller test measure is chosen as the ending test measure, it must have a neck at least large enough to accommodate the variation anticipated (0.02% range) between the passes in the same direction.

Leveling

The level position of the field standard test measure can be determined by placing a precision machinist's spirit level across the top of the neck of the test measure. This level verification must be determined in two directions, 90° apart, and shall be used to verify the permanently mounted spirit levels.

All field standard test measures shall be equipped with a minimum of two or more adjustable spirit levels, mounted at right angles to each other, or with equivalent leveling indicators on the upper cone in a protected position on the sides of the vessel. The adjusting screws for these levels shall be provided with a means of wire sealing and the level shall be equipped with a protective cover. Once set the levels shall be sealed and covered for protection.

When a field standard test measure is being used, it is important that it be used in the manner in which it was calibrated. For this reason it must always be placed with its vertical axis perpendicular to a level surface before reading the liquid level in the gauge sight glass. Horizontally mounted levels at right angles to each other can effectively be used to facilitate the leveling of the measures, provided the levels have been verified to be in a parallel plane with the cross-sectional area on top of the neck of the measure. This enables the test measures to be placed in an accurately determined level position prior to use.

If a trailer is used for mounting or transporting a field standard test measure, then it shall have provision for leveling. Any truck on which a field standard test measure is mounted shall be equipped with leveling jacks—one near each corner of the vehicle.

Irregular Test Measure Operations

Test Measure Pre-Filling

Sometimes during a waterdraw calibration it is necessary to accurately determine the volume of a partially filled test measure. This determination can be made by a method known as pre-filling. Pre-filling is accomplished by first filling a larger test measure

with an amount of water taken from a smaller volume test measure. The object being to bring the water drawn from the prover into the test measure up to a level that can be read on the gauge scale glass.

As an example, consider a prover with an approximate one-way volume of 145 gallons. Unfortunately, to accomplish this volume calibration, the only test measures available are a 100-gallon, a 50-gallon and a five-gallon. One method of calibrating this prover would be to fill the 100-gallon test measure once, and the five-gallon test measure nine times. This would not be recommended due to the large number of test measure fillings required, using a five-gallon test measure, which normally has a larger uncertainty value in its calibration. In addition, the flow rate would have to be stopped each time the five-gallon test measure is filled to allow it to be drained.

A more practical solution would be to fill the five-gallon test measure with water and then to pour this volume into either the 100-gallon or the 50-gallon test measure. Fill the remainder of this test measure from the prover.

The 100-gallon test measure, for Fill No. 1, has a base volume of 23,100 in.³

The 50-gallon test measure, for Fill No. 2, has a base volume of 11,550 in.³

The pre-fill five-gallon test measure has a base volume of 1,155 in.³

If only the 100-gallon and the 50-gallon test measures are used, at the end of the calibration pass the water level in the last test measure filled will not reach the neck, and therefore, will not have a scale reading. In this instance a pre-fill is used to pre-load the first measure filled with enough water to enable readings in the sight glasses on all the test measures filled to be achieved.

Treat the pre-fill volume as a separate test measure filling, but with both the Base Volume of the Test Measure (BMV) and the Scale Reading (SR) handled in a negative manner.

Fill the five-gallon test measure with wastewater. Take the temperature by immersion. After reading and recording the temperature take the Scale Reading (SR). Drain the five-gallon test measure into the 100-gallon test measure using the prescribed drain time and inversion angle.

In this example, let the Scale Reading on the five-gallon test measure be (-10).

Fill No. 1, of the 100-gallon test measure has a Scale Reading of (+ 20) in.³. Temperature is taken, while draining, after reading and recording the scale.

Fill No. 2, of the 50-gallon test measure has a Scale Reading of (- 6) in.³. Temperature is taken, while draining, after reading and recording the scale.

Pre-fill BMV = 1155 ...Treated as a negative: BMV = -1155

Pre-fill SR = -10 ...Treated as a negative: SR = +10

To determine the Adjusted Base Volume of the Test Measure (BMVa):

Pre-fill: BMV + SR = BMVa -1,155 + (+10) = -1,145

Fill No. 1: BMV + SR = BMVa 23,100 + (+20) = + 23,120

Fill No. 2: BMV + SR = BMVa 11,550 + (-6) = + 11,544

Total Volume 33,519 in³ (145.10 gals)

Calculating the Pre-fill volume the same way as any other test measure is calculated:

Calculate Fill No. 1: 23,120 x CTDW x CCTS = WD.....for Fill No. 1

Calculate Fill No. 2: 11,544 x CTDW x CCTS = WD.....for Fill No. 2

Calculate Pre-fill: -1,145 x CTDW x CCTS = WD.....for Pre-fill

Where: CTDW is the correction for the difference in density between the water in the prover and the water in the test measure.

CCTS is the combined correction factor for the effect of temperature on the steel of the prover and the test measure.

WD is the Base Volume of the Test Measure adjusted for the scale reading (SR) and corrected for the effects of CTDW and CCTS. See API *MPMS* Chapter 12.2.4 for detailed explanation of symbols and calculation procedures.

Test Measure Neck Draw

Sometimes during a waterdraw calibration it is necessary to accurately determine the volume of water in excess of the capacity of the last test measure filled. This determination can be made by a method known as neck drawing or neck draw down, in which the water level in the test measure neck is lowered before refilling the neck to accomplish the neck draw. It is possible that this procedure may have to be repeated several times in extreme cases.

As an example, consider a prover with an approximate 1-way volume of 153 gallons. Unfortunately, to accomplish this volume calibration, the only test measures available are a 100-gallon and a 50-gallon. The total capacity of the combined filling of these two test measures would range from a minimum volume of 148.5 gallons to a maximum volume of 151.5 gallons.

The 100-gallon test measure for Fill No. 1 has a base volume of 23,100 in³

The 50-gallon test measure for Fill No. 2 has a base volume of 11,550 in³

After filling both test measures to their maximum readable scale levels there will still be approximately one-and-a-half gallons of water remaining in the prover. This volume of water will somehow need to be accommodated in a test measure in order to be measured.

Fill No. 1, of the 100-gallon test measure has a Scale Reading of (+230) cubic inches. Take the temperature by immersion. After reading and recording the temperature take the Scale Reading (SR).

Fill No. 2, of a 50-gallon test measure has a Scale Reading of (+100) cubic inches. Take the temperature while draining, after reading and recording the Scale Reading (SR).

Neck Draw: Lower the water level in the neck of the 100-gallon test measure, to waste, by careful manipulation of the drain valve, until the water level reaches the lowest readable value on the scale. Close the drain-valve and take the scale reading.

Opening scale reading: SR (opening) = -220 cubic inches

Draw water from the prover refilling the neck of the 100-gallon test measure, until the detector switch activates and shuts down the prover calibration run.

Closing scale reading: SR (closing) = +215 cubic inches

Treat this neck fill as if it were a separate field standard test measure

BMV = (0) zero

The temperature is taken by immersion, of the NECK portion ONLY, after reading and recording the closing Scale Reading (SR).

To rationalize the Scale Reading:(SR) = [SR (closing) – SR (opening)]
 = + 215 – (-220)
 = + 215 + (220)
 = + 435 in.³

To determine BMVa:

Fill No. 1: BMV + SR = BMVa 23,100 + (+230) = +23,330 in.³

Fill No. 2: BMV + SR = BMVa 11,550 + (+100) = +11,650 in.³

Neck Draw: BMV + SR = BMVa zero + (+435) = +435 in.³

Total Volume = 35,415 in.³ (153.31 gals)

Calculate the Neck Fill as any other measure fill is calculated.

Calculate Fill No. 1: 23,330 x CTDW x CCTS = WD ...for Fill No. 1

Calculate Fill No. 2: 11,650 x CTDW x CCTS = WD ...for Fill No. 2

Calculate Neck Fill: 435 x CTDW x CCTS = WD ...for Neck Draw

Similar situations can often occur in the calibration of new provers, or also when provers have been modified or worked on, such that in these cases the prover volume is not exactly known. Therefore, the first calibration run is very often a guess as to where the actual final volume will finish, relative to the test measures being used to determine the volume. In this situation, it often happens that the operator can find himself having to perform several neck draws to complete the calibration run, just because of the fact that this prover volume is not precisely known. Use of this method will allow a precise volume to be decided, and enable the operator to refine the test measure fillings for the additional calibration runs required to be made.

Test Measure Combination Pre-Fill and Neck Draw

It is also possible to have a situation where a test measure pre-fill and a test measure neck draw are both necessary during the same prover calibration pass/run. Although this situation is not common, it is something that operators should be aware of, and can easily handle should this condition arise during a prover calibration.

Following on from the previous examples, consider a prover calibration with an approximate one-way volume of 147.5 gallons. Unfortunately, in this case, to accomplish this volume calibration, the only suitable test measures available are a 100-gallon, a 50-gallon and a five gallon. Therefore, to perform the prover calibration with these test measures would require the following sequence of events:

Fill the 100-gallon test measure with a five-gallon water pre-fill from the five-gallon test measure, then fill the test measure up to the top of the readable scale with water drawn from the prover.

Next, fill the 50-gallon test measure to the top of its readable scale with water draw water. At this point, we have the following situation:

- The volume in the 100-gallon test measure is 101 gallons from which we need to subtract five gallons.
- The volume in the 50-gallon test measure is 50.5 gallons.
- The total volume equals: $(101 + 50.5 - 5) = 146.5$ gallons.

Therefore, with both test measures filled, and a pre-fill of five gallons, we have managed to hold a total amount of 146.5 gallons water. However, we are trying to contain 147.5 gallons and have need of room in a test measure for an additional one gallon of water.

At this point, it is necessary to draw down the neck of the 100-gallon test measure. Draw the water level down to the lowest readable scale line, this will make a total volume space of two gallons available in the neck of the 100-gallon test measure, and allow the prover calibration run to complete.

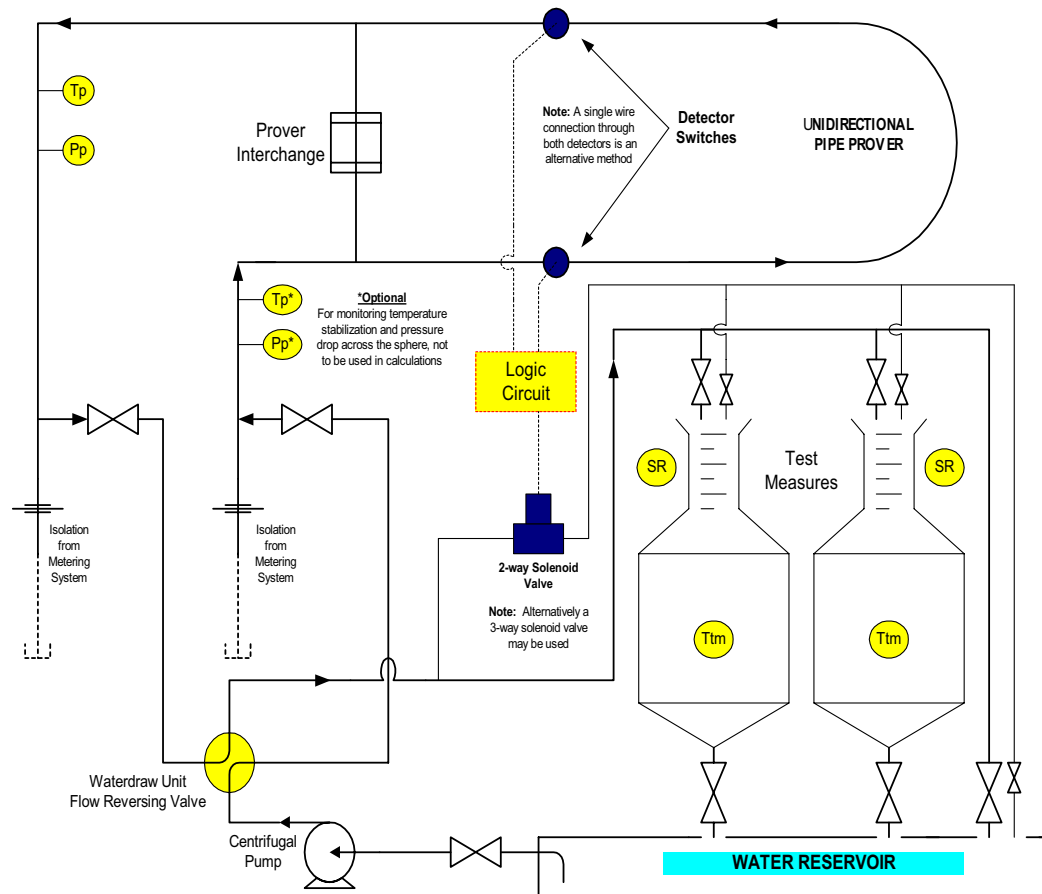

Figure 1—Schematic Drawing of a Typical Layout for a Waterdraw Calibration of a Displacement Type Unidirectional Prover with a Free Displacer using Top-filling Test Measures

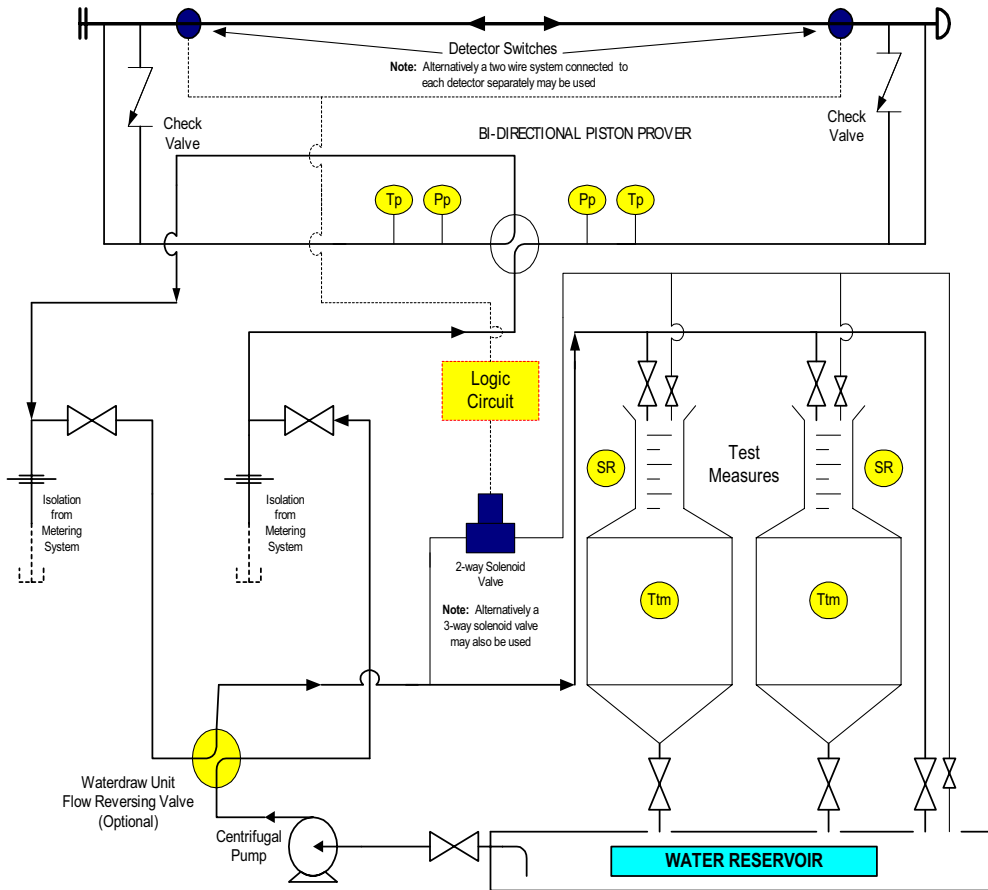

Figure 2A—Schematic Drawing of a Typical Layout for a Waterdraw Calibration of a Displacement Type Bi-directional Prover with a Free Piston Displacer and Check Valves in the Manifold using Top-filling Test Measures

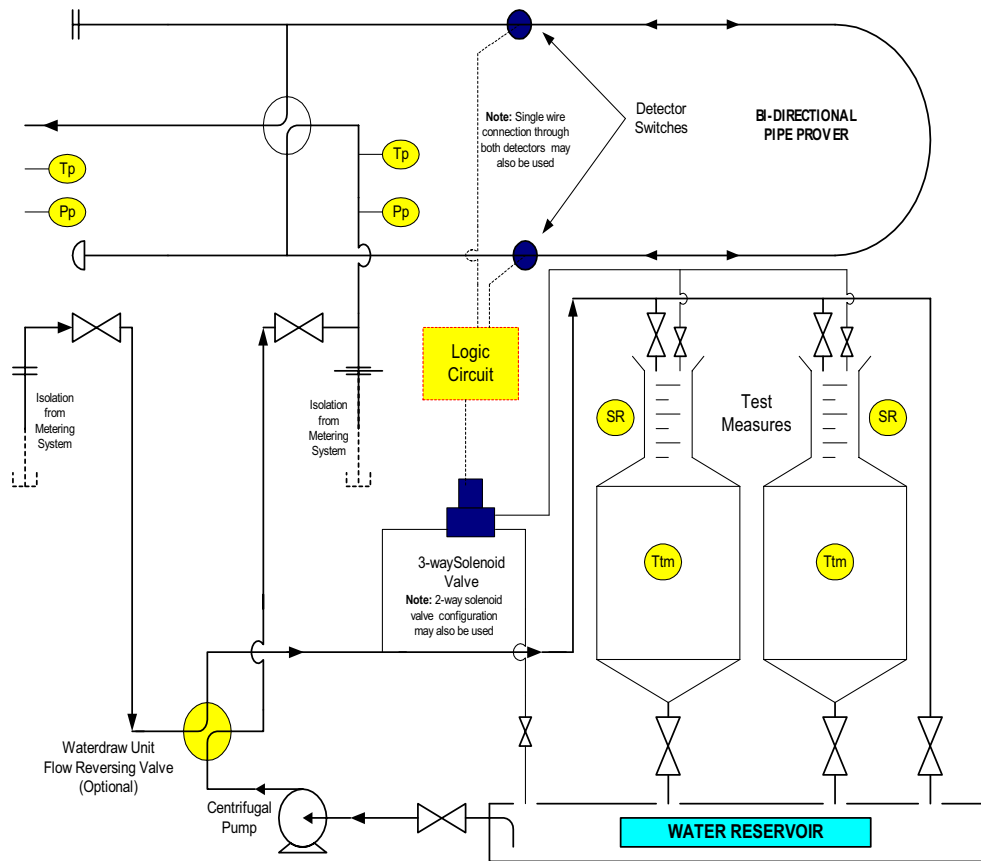

Figure 2B—Schematic Drawing of a Typical Layout for a Waterdraw Calibration of a Displacement Type Bi-directional Prover with a Free Sphere Displacer using Top-filling Test Measures

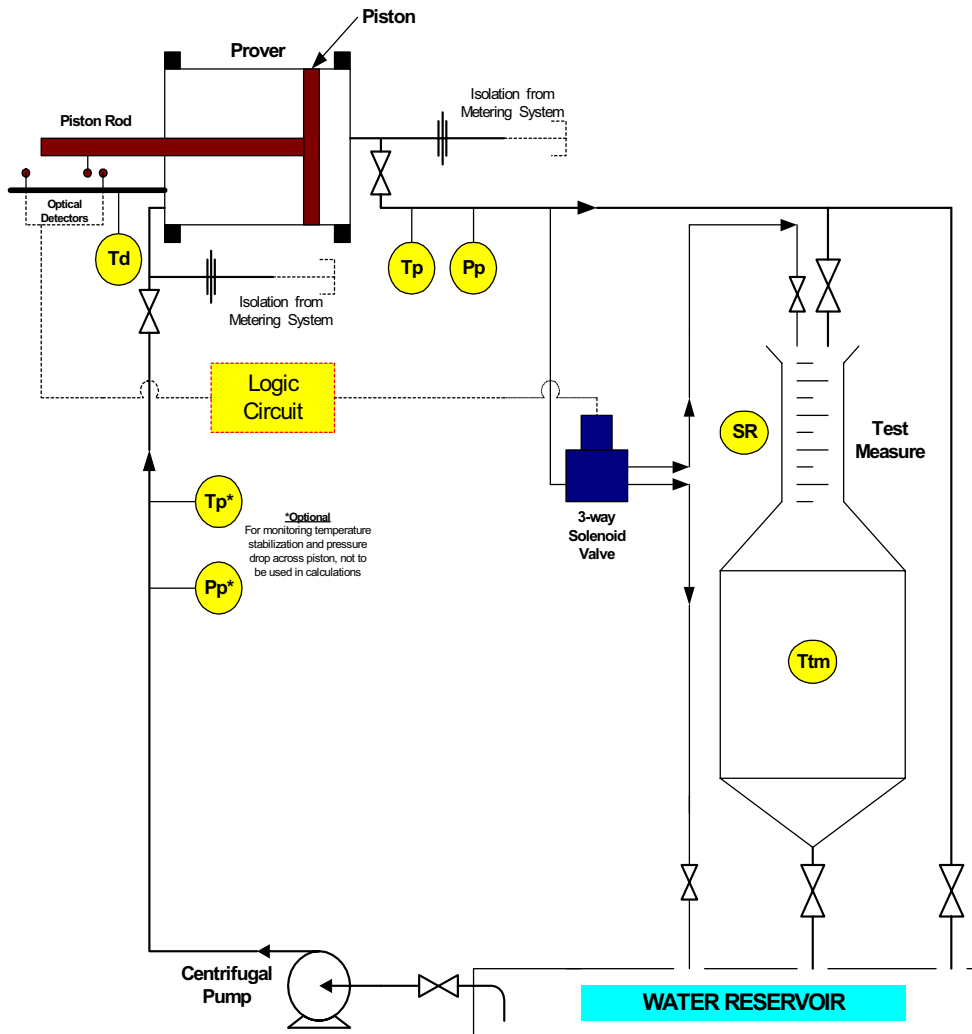

Figure 3A—Schematic Drawing of a Typical Layout for a Waterdraw Calibration of the Downstream Volume of a Displacement Prover with a Captive Displacer and External Detectors using Top-filling Test Measures

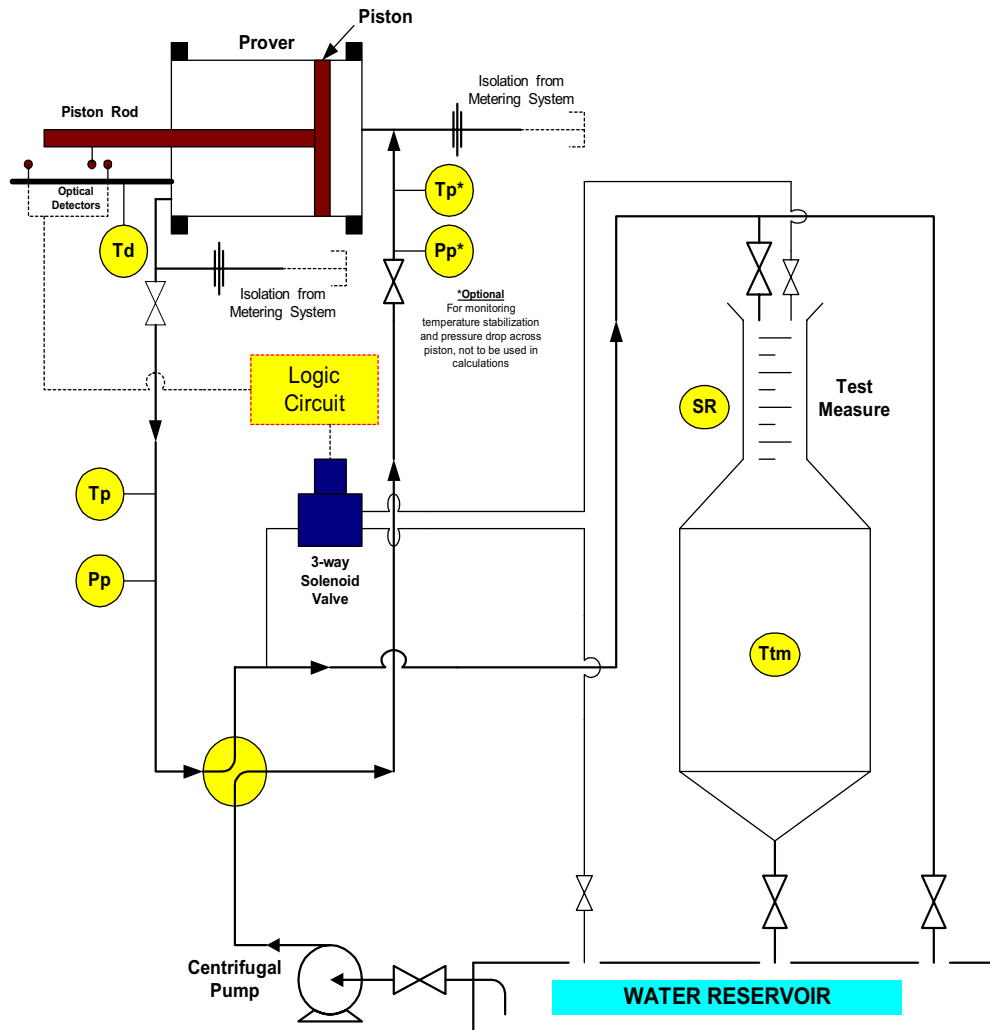

Figure 3B—Schematic Drawing of a Typical Layout for a Waterdraw Calibration of the Upstream Volume of a Displacement Prover with a Captive Displacer and External Detectors using Top-filling Test Measures

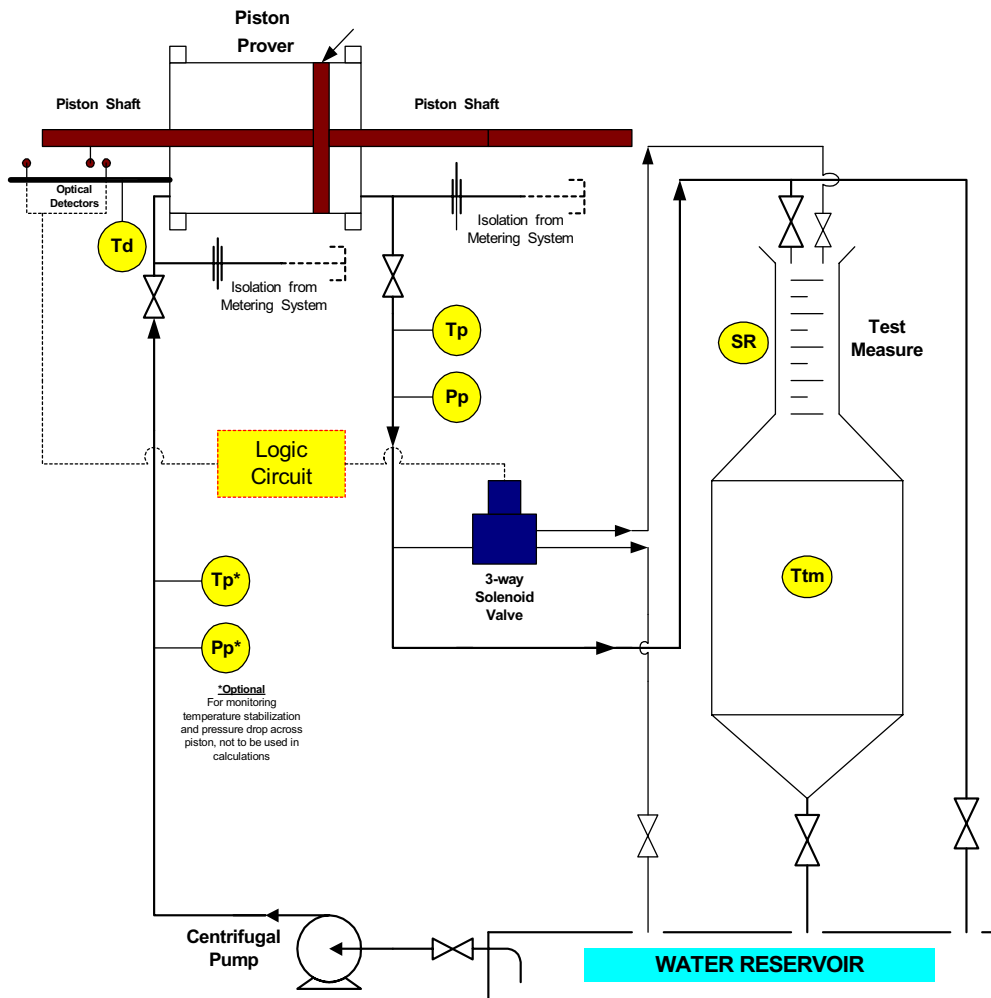

Figure 3C—Schematic Drawing of a Typical Layout for a Waterdraw Calibration of a Displacement Prover with Equal Size Diameter Shafts on Both Sides of a Captive Displacer and External Detectors using Top-filling Test Measures

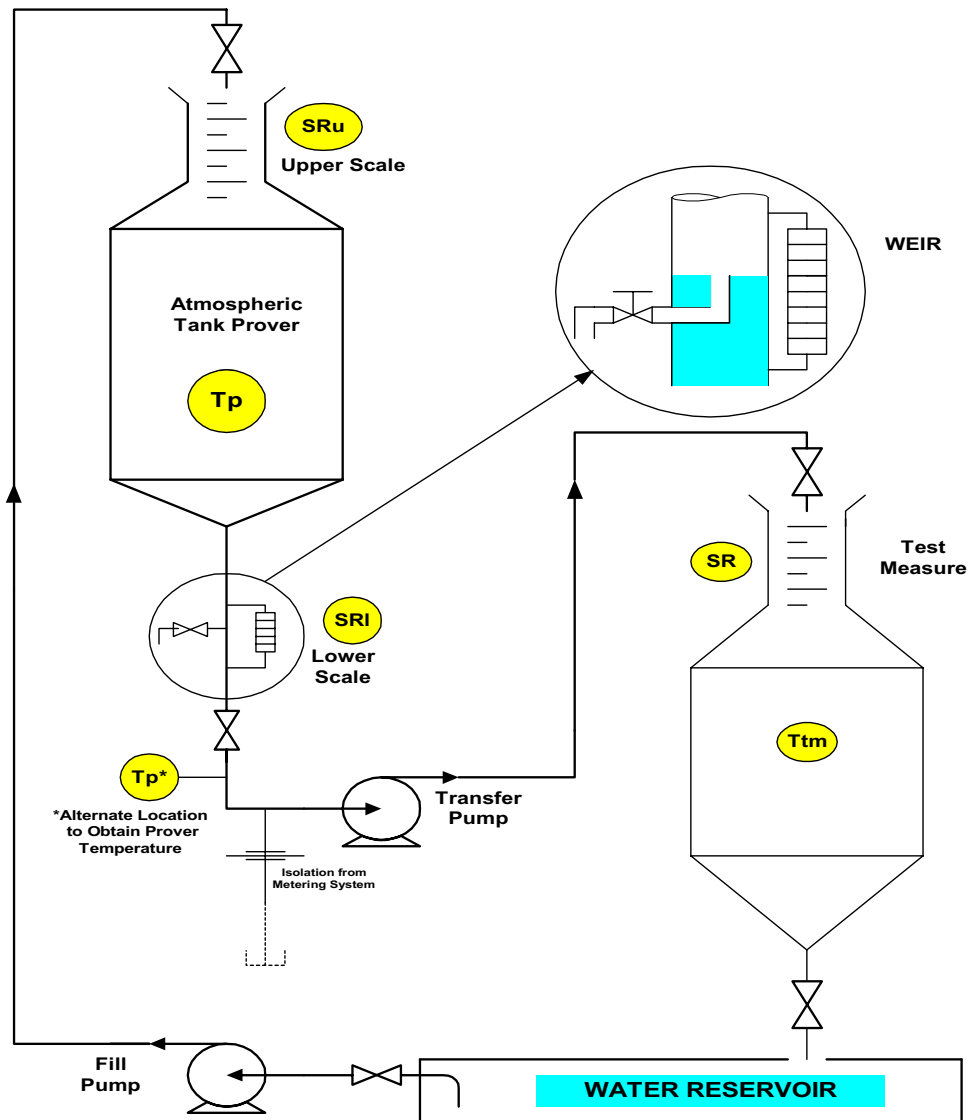

Figure 4A—Schematic Drawing of a Typical Layout for a Waterdraw Calibration of a Volumetric Tank Prover with a Bottom Weir using Top-filling Test Measures

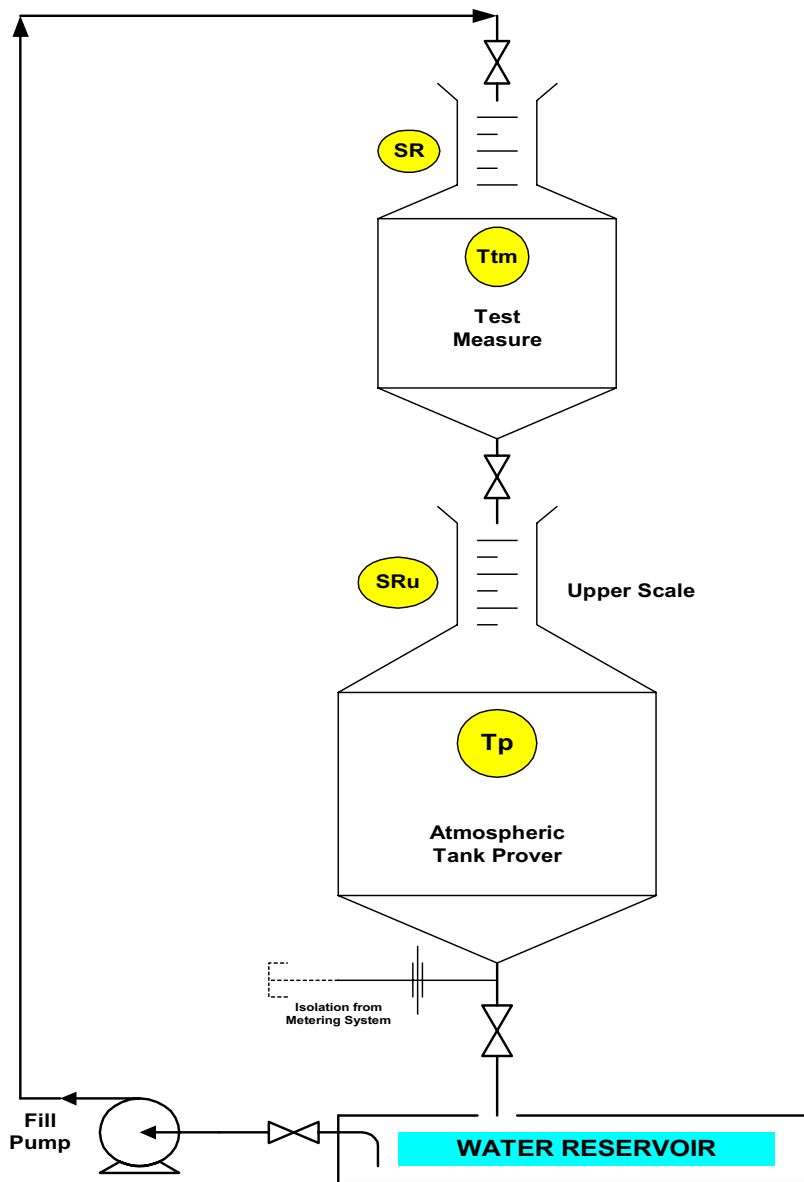

Figure 4B—Schematic Drawing of a Typical Layout for a Waterdraw Calibration of a Volumetric Tank Prover with a Dry Bottom using the Water-fill Method and using Top-filling Test Measures.

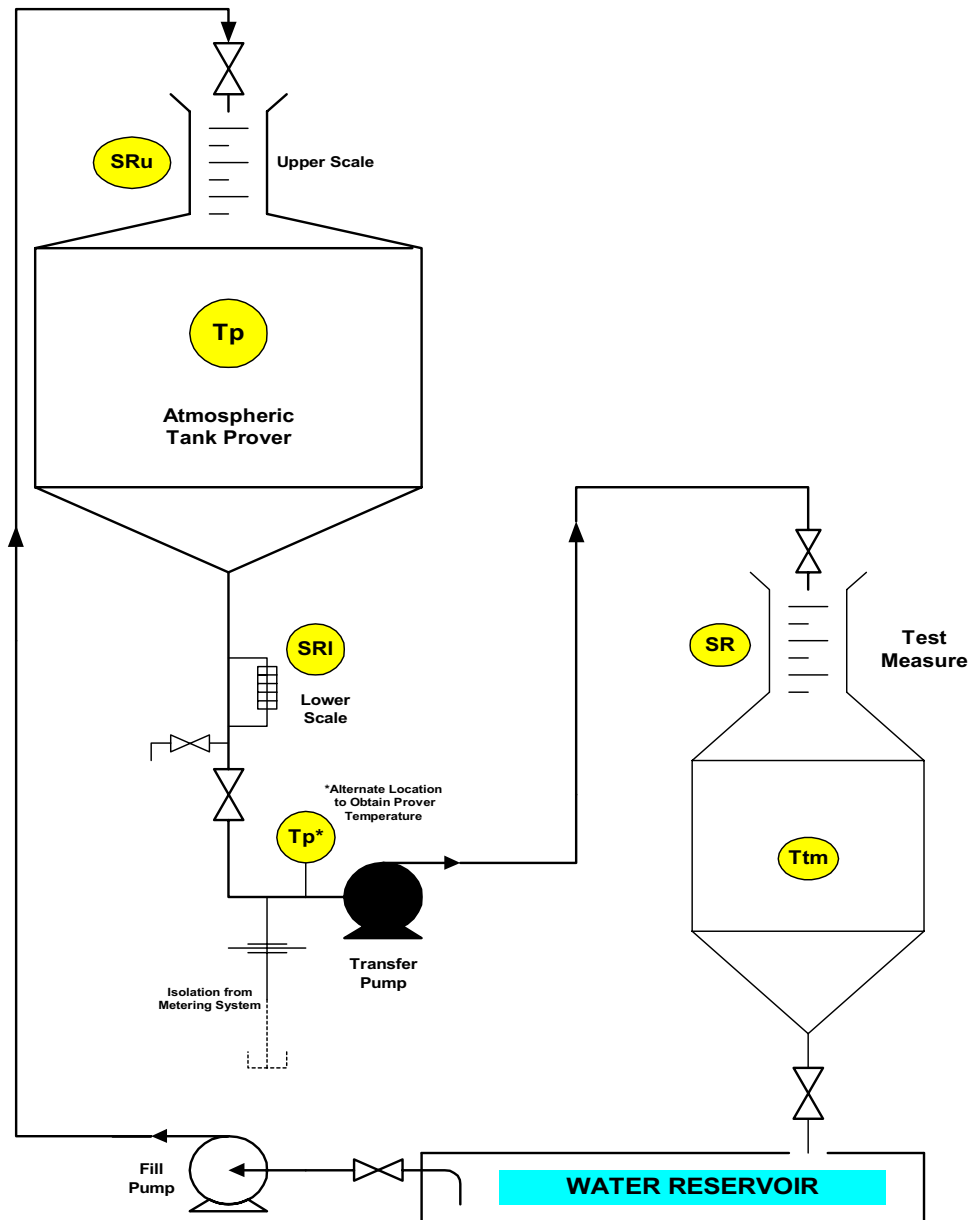

Figure 4C—Schematic Drawing of a Typical Layout for a Waterdraw Calibration of a Volumetric Tank Prover with a Wet Bottom using Top-filling Test Measures

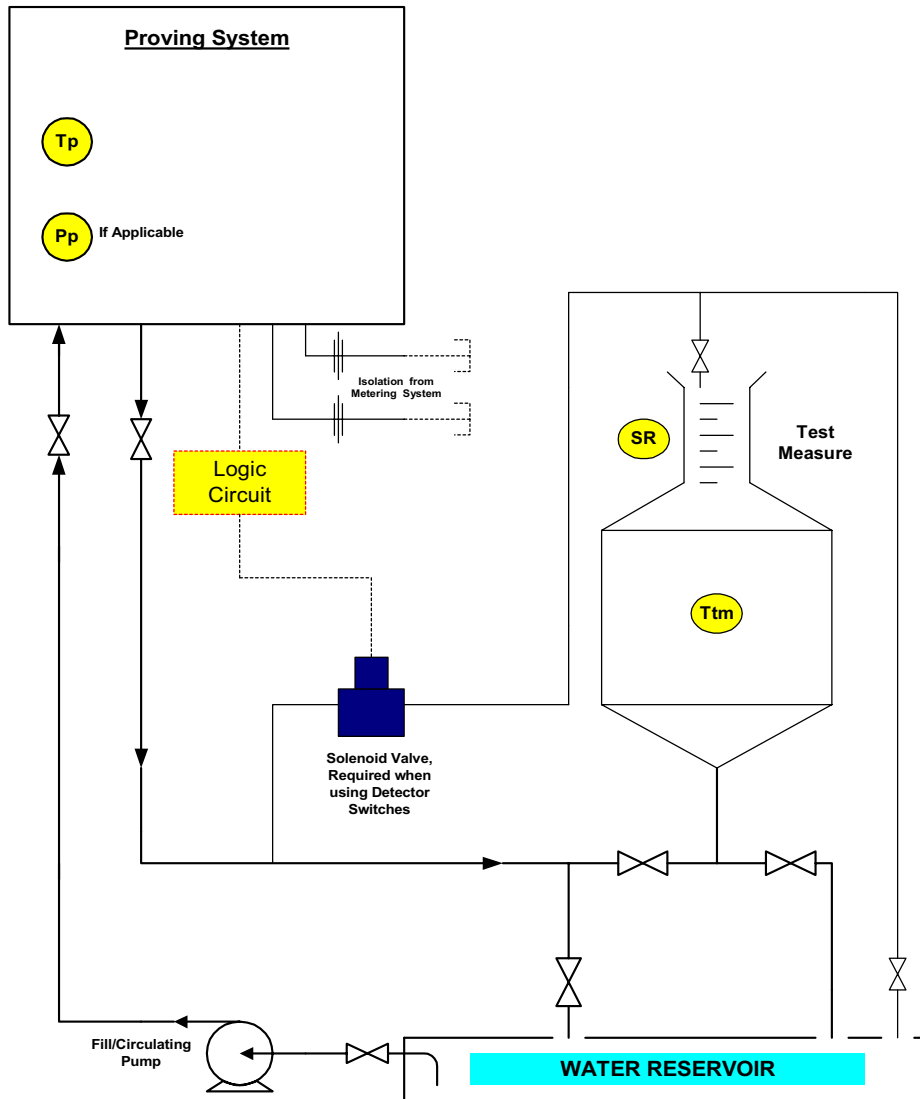

Figure 5—Alternate Method—Schematic Drawing of a Typical Layout for a Waterdraw Calibration of a Proving System using Bottom-filling Test Measures



**American Petroleum Institute
2005 Publications Order Form**

Effective January 1, 2005.

API Members receive a 30% discount where applicable.

The member discount does not apply to purchases made for the purpose of resale or for incorporation into commercial products, training courses, workshops, or other commercial enterprises.

Available through Global Engineering Documents:

Phone Orders: 1-800-854-7179 (Toll-free in the U.S. and Canada)
303-397-7956 (Local and International)

Fax Orders: 303-397-2740

Online Orders: www.global.ihs.com

Date: _____

API Member (Check if Yes)

Invoice To (Check here if same as "Ship To")

Name: _____
Title: _____
Company: _____
Department: _____
Address: _____

City: _____ State/Province: _____
Zip/Postal Code: _____ Country: _____
Telephone: _____
Fax: _____
E-Mail: _____

Ship To (UPS will not deliver to a P.O. Box)

Name: _____
Title: _____
Company: _____
Department: _____
Address: _____

City: _____ State/Province: _____
Zip/Postal Code: _____ Country: _____
Telephone: _____
Fax: _____
E-Mail: _____

Quantity	Product Number	Title	SO★	Unit Price	Total

Payment Enclosed **P.O. No.** (Enclose Copy) _____

Charge My Global Account No. _____

VISA **MasterCard** **American Express** **Diners Club** **Discover**

Credit Card No.: _____

Print Name (As It Appears on Card): _____

Expiration Date: _____

Signature: _____

Subtotal	
Applicable Sales Tax (see below)	
Rush Shipping Fee (see below)	
Shipping and Handling (see below)	
Total (in U.S. Dollars)	

★ To be placed on **Standing Order** for future editions of this publication, place a check mark in the SO column and sign here:

Pricing and availability subject to change without notice.

Mail Orders – Payment by check or money order in U.S. dollars is required except for established accounts. State and local taxes, \$10 processing fee*, and 5% shipping must be added. Send mail orders to: **API Publications, Global Engineering Documents, 15 Inverness Way East, M/S C303B, Englewood, CO 80112-5776, USA.**

Purchase Orders – Purchase orders are accepted from established accounts. Invoice will include actual freight cost, a \$10 processing fee*, plus state and local taxes.

Telephone Orders – If ordering by telephone, a \$10 processing fee* and actual freight costs will be added to the order.

Sales Tax – All U.S. purchases must include applicable state and local sales tax. Customers claiming tax-exempt status must provide Global with a copy of their exemption certificate.

Shipping (U.S. Orders) – Orders shipped within the U.S. are sent via traceable means. Most orders are shipped the same day. Subscription updates are sent by First-Class Mail. Other options, including next-day service, air service, and fax transmission are available at additional cost. Call 1-800-854-7179 for more information.

Shipping (International Orders) – Standard international shipping is by air express courier service. Subscription updates are sent by World Mail. Normal delivery is 3-4 days from shipping date.

Rush Shipping Fee – Next Day Delivery orders charge is \$20 in addition to the carrier charges. Next Day Delivery orders must be placed by 2:00 p.m. MST to ensure overnight delivery.

Returns – All returns must be pre-approved by calling Global's Customer Service Department at 1-800-624-3974 for information and assistance. There may be a 15% restocking fee. Special order items, electronic documents, and age-dated materials are non-returnable.

***Minimum Order** – There is a \$50 minimum for all orders containing hardcopy documents. The \$50 minimum applies to the order subtotal including the \$10 processing fee, excluding any applicable taxes and freight charges. If the total cost of the documents on the order plus the \$10 processing fee is less than \$50, the processing fee will be increased to bring the order amount up to the \$50 minimum. This processing fee will be applied before any applicable deposit account, quantity or member discounts have been applied. There is no minimum for orders containing only electronically delivered documents.

There's more where this came from.

The American Petroleum Institute provides additional resources and programs to the oil and natural gas industry which are based on API® Standards. For more information, contact:

- API Monogram® Licensing Program Phone: 202-962-4791
Fax: 202-682-8070
- American Petroleum Institute Quality Registrar (APIQR®) Phone: 202-962-4791
Fax: 202-682-8070
- API Spec Q1® Registration Phone: 202-962-4791
Fax: 202-682-8070
- API Perforator Design Registration Phone: 202-962-4791
Fax: 202-682-8070
- API ISO/TS 29001 Registration Phone: 202-962-4791
Fax: 202-682-8070
- API Training Provider Certification Program Phone: 202-682-8490
Fax: 202-682-8070
- Individual Certification Programs Phone: 202-682-8064
Fax: 202-682-8348
- Engine Oil Licensing and Certification System (EOLCS) Phone: 202-682-8516
Fax: 202-962-4739
- API PetroTEAM™ (Training, Education and Meetings) Phone: 202-682-8195
Fax: 202-682-8222

Check out the API Publications, Programs, and Services Catalog online at www.api.org.



Helping You Get
The Job Done Right.®

Additional copies are available through Global Engineering Documents at (800) 854-7179 or (303) 397-7956

Information about API Publications, Programs and Services is available on the World Wide Web at: <http://www.api.org>

