

INSTRUCTION MANUAL

FL2100B

YAESU MUSEN CO., LTD.

TOKYO, JAPAN

FL-2100B LINEAR AMPLIFIER

GENERAL

The FL-2100B Linear Amplifier is designed to match the FT-101B/277B transceivers in appearance and drive requirements to run high power input covering the ham bands 80 through 10 meters.

The FL-2100B uses a pair of 572B/T160 transmitting triodes in a class B grounded grid circuit configuration. The tubes are forced-air cooled by two very quiet high speed internal fans.

Automatic Level Control circuit controls the exciter gain to allow the highest average power without distortion caused by peak clipping. Change-over circuit biases the tubes to cut-off, eliminating unwanted heat and diode noise generation when receiving.

An internal changeover relay feeds the antenna to the exciter for barefoot operation when the FL-2100B is turned off or is on standby condition. A built-in SWR bridge measures SWR on by barefoot and linear operations.

The built-in solid state power supply requires no warm-up period and provides excellent voltage regulation.

CAUTION

DO NOT TURN ON THE FL-2100B WITH THE TOP SHIELD COVER REMOVED. THE HIGH VOLTAGE SAFETY LOCK SHORTS OUT THE HIGH VOLTAGE AND WILL DAMAGE THE POWER SUPPLY CIRCUIT.

full scale at SWR switch "F" position. Turn SWR switch to "R" position, then SWR may be read directly from upper scale of the meter.

THEORY OF OPERATION

The FL-2100B is designed to use two 572B/T 160 zero bias triodes in a class B grounded grid configuration.

The RF driving power delivered to the input is applied to the tube filaments through a changeover relay and a pi-network on each band which is selected by the input switch S2b. The input switch is ganged to the band switch S1.

The RF voltage appearing on the grid of the tube is coupled through C203 to ALC rectifier diodes D201 and D202. The plate potential of D201 is determined by R1, R2, R3, so that adequate automatic level control voltage is available to control the exciter. The bias is set by R4 for 0.09 Amps idle current. In standby, the cold end of S4 is opened so that bias voltage cuts off the tubes. The plate circuit is coupled to the 50 ohm output load by an adjustable pi-network through the SWR bridge circuit.

SERVICING

WARNING

EXTREME CAUTION SHOULD BE TAKEN WHENEVER MAKING ANY ADJUSTMENTS INSIDE THE CABINET. BEFORE REMOVING THE CABINET UNPLUG THE POWER PLUG FROM THE AC LINE.

Removing the Bottom Cover and the Cabinet

After disconnecting the power cord from the AC line, the bottom cover can be removed by taking out the four screws on it.

After removing four screws on the front end and four on the bottom of the cabinet, the cabinet can be slid out backwards from the chassis and panel assembly.

Removing Shield Cover

After removing the cabinet, the shield cover of the PA compartment can be removed by taking out two screws on the shield cover. The safety lock shorts out the charge condensed in the capacitor.

Tube Replacement

If it becomes necessary to replace the tubes in the FL-2100B, the same manufacturer brand should be used.

Trouble Shooting

During long periods of operation, it is quite possible that some problem will arise which cannot be cured by tube substitution. If this occurs, it is recommended that you either return it to your dealer or write us in detail.

Input Coil Alignment

The input coils are adjusted at the factory for the center of each band and are broad enough to cover the entire band. However, if the tubes are replaced with a brand other than originally supplied, the input coils may have to be realigned. The alignment is done with a 50 ohm SWR meter inserted between the exciter output and the FL-2100B's RF input coax jack. First disconnect the FL-2100B from the power line, remove the bottom cover and the cabinet disconnect the wiring from the high voltage terminals of the transformer.

The amplifier should be connected to the exciter as for normal operation with the exception of the SWR meter in the input line. Preset the controls as follows:

Band Switch	:	On desired band to be tuned
Loading	:	Fully counter-clockwise
Plate Control	:	In the position described on page 7

With the exciter tuned up on CW in the middle of the band to be tuned, turn on the FL-2100B. The amplifier now works without plate voltage. Extreme care should be taken, because there is high voltage AC on the secondary terminals of the power transformer.

Increase the output from the exciter until the amplifier plate meter read 0.1 Amps. Tune the plate control for a dip in plate current and tune the slug on the correct input coil for a minimum reflected power reading on the SWR meter that is connected to the input line.

After re-alignment, disconnect the power cord from the AC line and reconnect the disconnect wiring to the secondary terminals of the transformer.

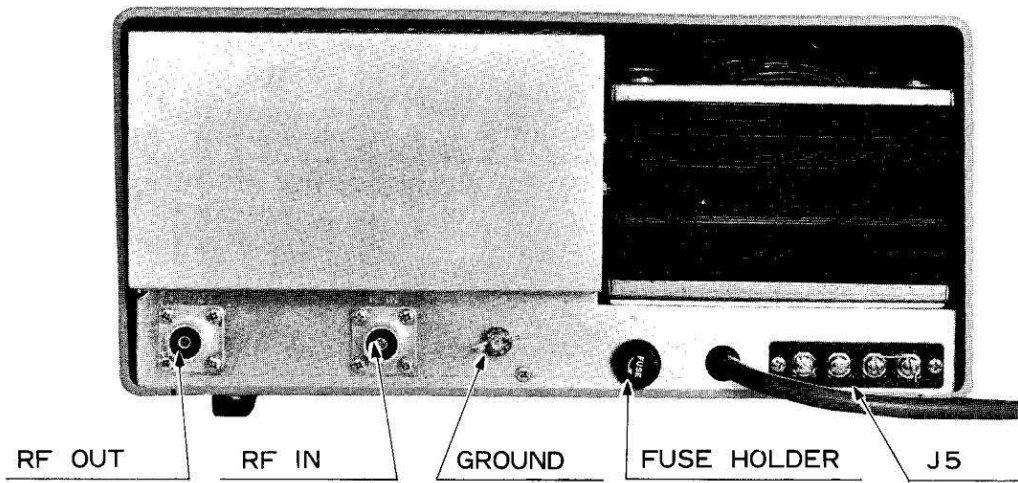

REAR VIEW

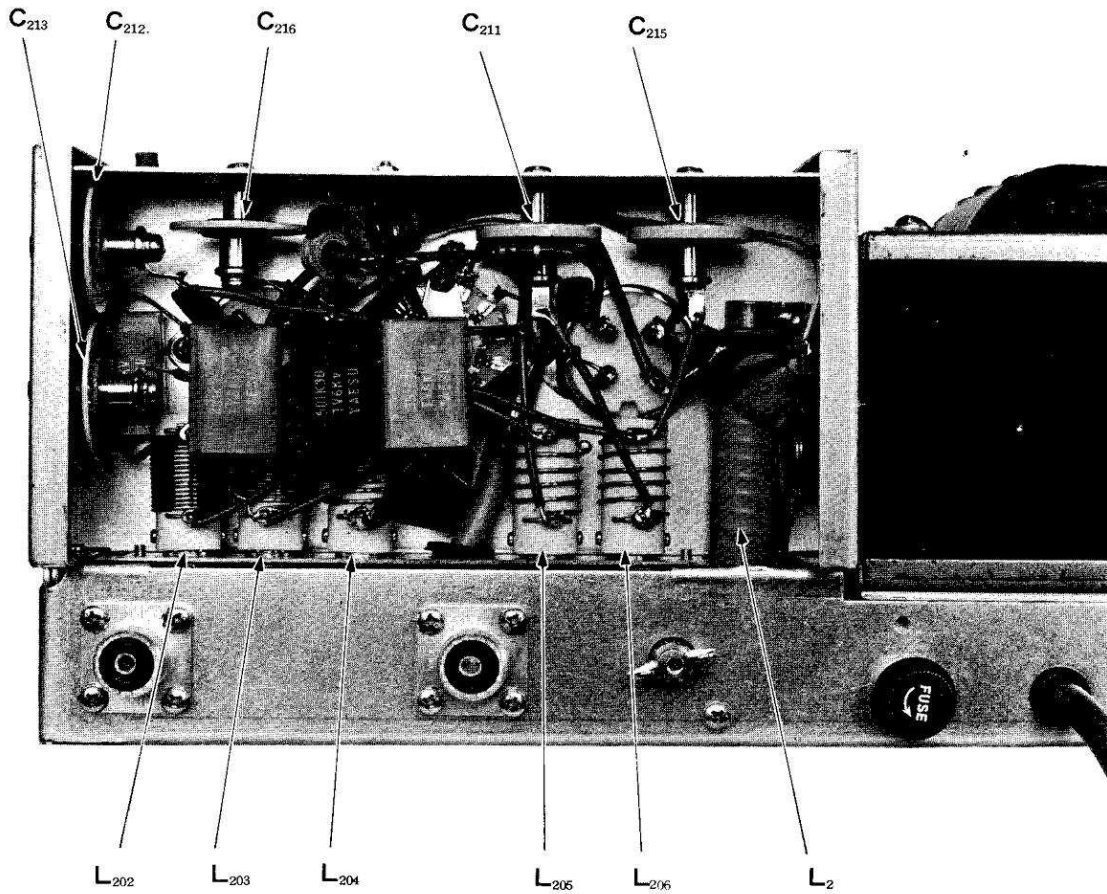

INPUT TUNING CIRCUIT

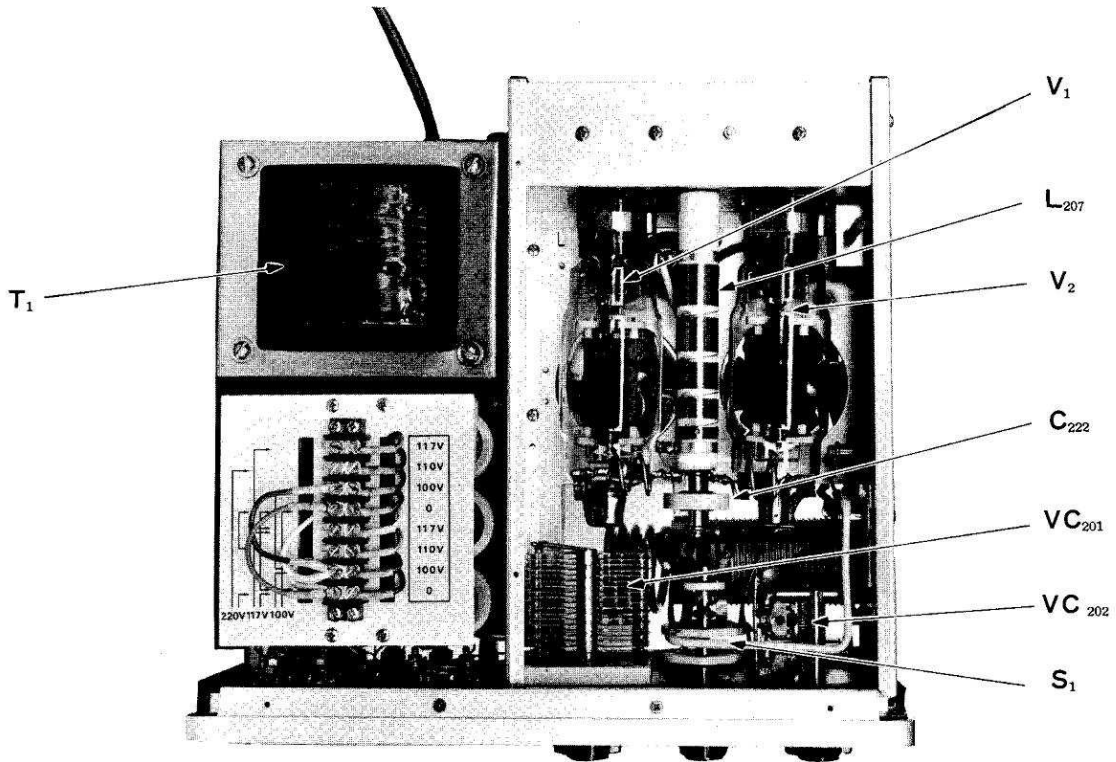

TOP VIEW

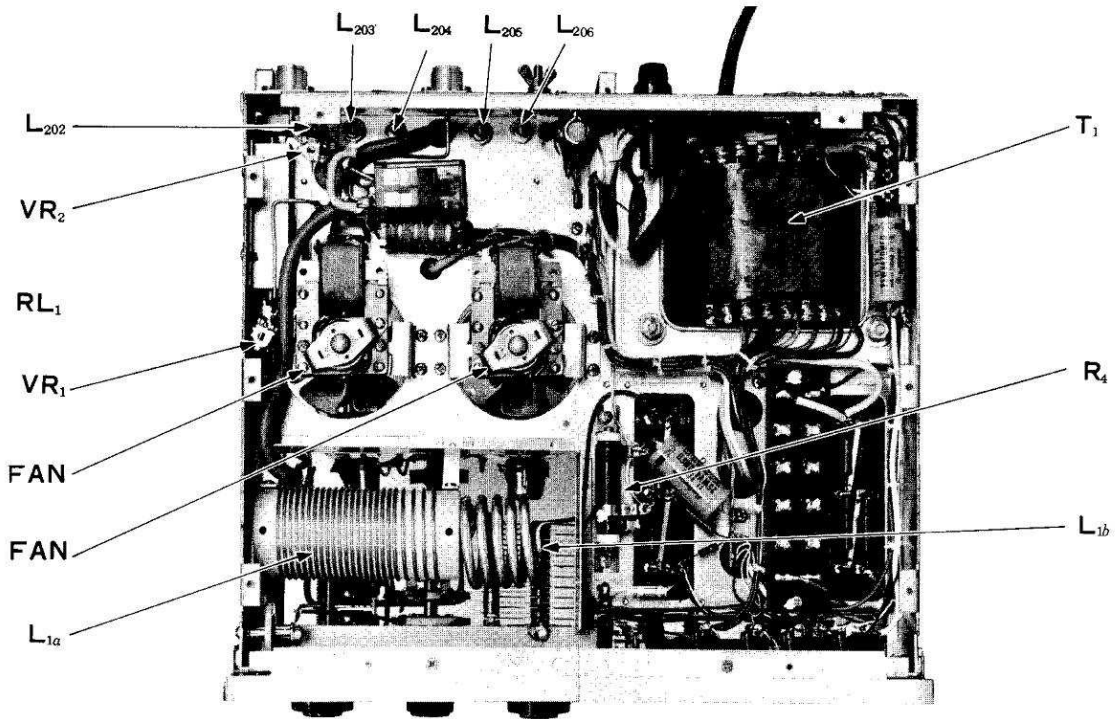

BOTTOM VIEW

SPECIFICATIONS

Circuit	:	Grounded Grid Class B
Frequency Coverage	:	Ham bands 80 through 10 meters
Plate Input	:	1200 Watts PEP, 1000 Watts CW and 600 Watts AM
Plate voltage	:	2400 Volts DC
Drive Requirement	:	100 Watts PEP
Input Impedance	:	50 ohms, unbalanced
Output Impedance	:	50 - 75 ohms, unbalanced
Third Order Distortion	:	30 db or better at 1000 Watts PEP
Tube Complement	:	2 × 572B/T 160
Cooling	:	Forced-air cooling
Power Requirements	:	AC 100, 110, 117 Volts 50/60Hz 18 Amps AC 200, 220, 234 Volts 50/60Hz 9 Amps
Dimensions	:	13 $\frac{1}{2}$ " Wide, 6 " High, 11 $\frac{1}{2}$ " Deep
Weight	:	41 lbs

FRONT PANEL CONTROLS

POWER-OFF	:	Rocker switch turns power on.
OPER-STBY	:	Rocker switch applies Bias when standby and relay is disengaged.
SWR-IP	:	Rocker switch selects either SWR or plate current meter reading.
F-R	:	Rocker switch selects either forward or reflected SWR bridge reading.
SENS	:	Potentiometer adjusts meter sensitivity for SWR measurement.
PLATE	:	Plate capacitor in tank circuit.

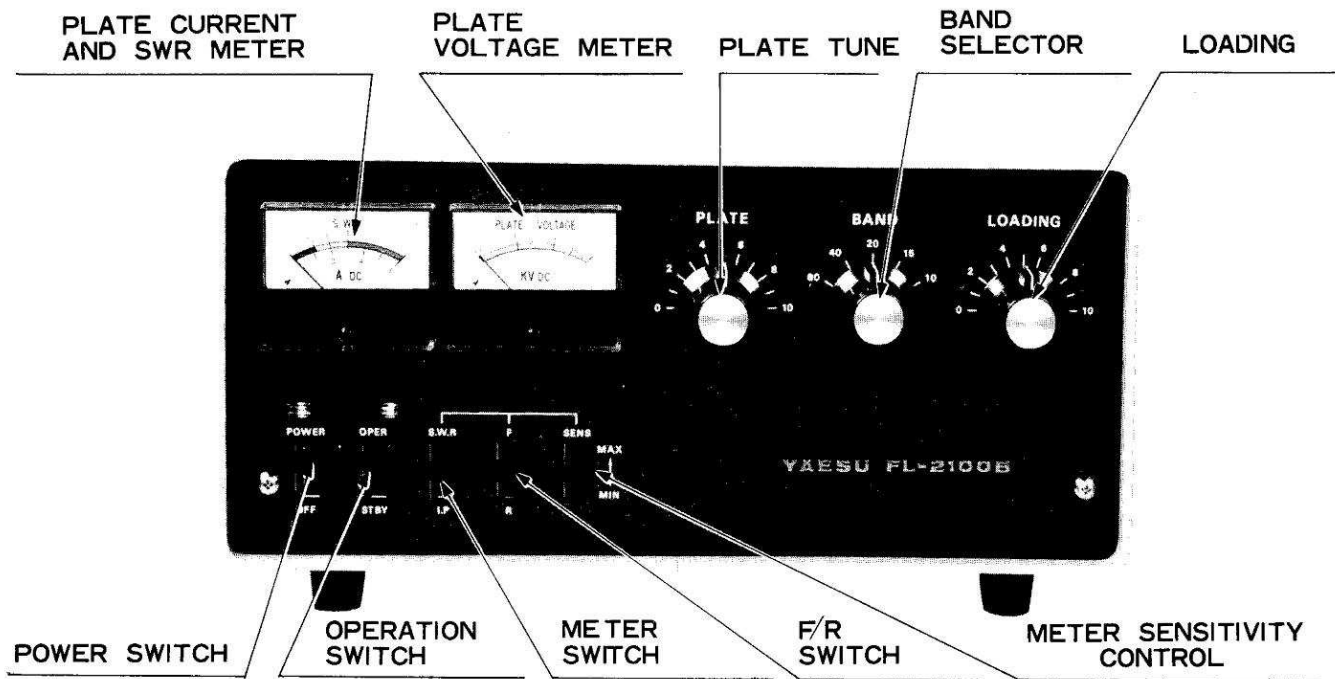

FRONT VIEW

INSTALLATION

The FL-2100B has been designed incorporating a safety lock to prevent dangerous high voltage shock. However, extreme care is recommended when servicing inside the cabinet.

Unpacking

Carefully remove FL-2100B from the packing carton and examine them for any visible shipping damage, check the control knobs and switches for complete freedom of action.

In general, care should be taken to insure that enough space is allowed around the amplifier cabinet to permit adequate air circulation within the linear amplifier. Do not cover the top of the FL-2100B with books, papers or other equipment. Do not insert anything under the bottom of the FL-2100B or overheating may result.

POWER REQUIREMENT

The FL-2100B has a built-in power supply which can be operated from either 100, 117 or 220 volts AC 50-60 Hz.

Be sure that the voltage marked on the rear of the FL-2100B agrees with the local AC supply voltage.

CAUTION

PERMANENT DAMAGE WILL RESULT IF IMPROPER AC SUPPLY VOLTAGE IS APPLIED TO THE FL-2100B

It is recommended that the FL-2100B is operated from its own 220 volt 10 amp or greater circuit. If 117 or 100 volts is all that is available, it should be fused for 20 Amps, circuit conductors should be larger than # 10 and no other equipment should be operated from this circuit. DO NOT, under any circumstances, operate the FL-2100B from a 117 volt lighting circuit, as the circuit conductors are not large enough to carry this load.

The following diagram shows the wiring connections for 117 and 220 volt operation. Connections must be made as shown or serious damage may result.

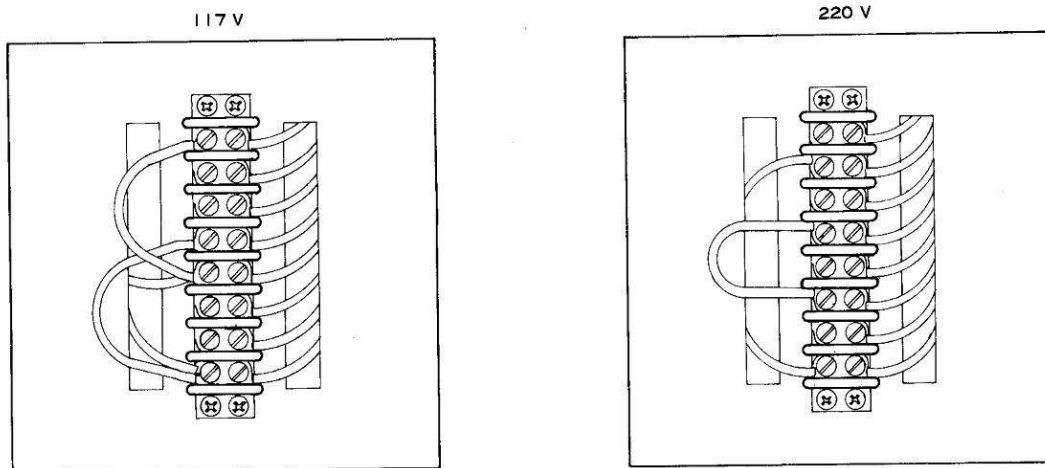

ANTENNA REQUIREMENT

The FL-2100B has been designed for use with an antenna resonant at the operating frequency and having approximate impedance within the limit of 40 to 80 ohms. The nominal output impedance of the FL-2100B is 50 ohms. When the impedance of the antenna used is far from this value, it is recommended that an antenna matching network be used which will allow the FL-2100B to work into its nominal 50 ohm load for maximum power transfer into the antenna.

GROUND REQUIREMENT

The FL-2100B should be connected to a good earth ground through as short and as large a gauge wire as possible for best performance and maximum safety. A connecting post marked "GND" is provided on the rear apron of the chassis.

CAUTION

NEVER OPERATE THE FL-2100B WITHOUT CONNECTING IT TO AN EARTHGROUND, AND AN ANTENNA OR 50 OHM DUMMY LOAD, OR SERIOUS DAMAGE MAY RESULT.

EXCITER REQUIREMENT

To operate the FL-2100B at its maximum power input, it will be required that the exciter deliver 100 Watts PEP SSB output.

The exciter should be placed as close to the amplifier as practical to avoid long coax and ground connections.

ALC

On the rear of the FL-2100B, a terminal is provided for connection to the exciter of the ALC voltage which controls the gain of the exciter to prevent distortion caused by peak clipping.

Relay Control

RY and E terminal on the rear of the FL-2100B are provided for connection to the exciter relay circuit which is normally open, and which closes on transmit and thus keys the FL-2100B at the same time. E terminal should be connected to ground for exciters whose relay contact connects to ground on transmit. The terminals are jumpered with a wire for testing purposes when the unit is shipped from the factory.

OPERATION

CAUTION

BE SURE THAT THE FL-2100B IS CONNECTED TO A 50 OHM ANTENNA SYSTEM OR A 50 OHM DUMMY LOAD AND THAT THE PROPER POWER CONNECTION HAS BEEN MADE FOR THE LINE VOLTAGE THAT IS TO BE USED. (SEE PAGE 4)

For all modes of operation, the FL-2100B is tuned up with a single R.F. frequency driving it. The exciter may be tuned up on CW into the antenna connected to the FL-2100B with operation switch at STBY position, or by leaving the FL-2100B power off. After the exciter has been tuned up, turn the exciter to standby and turn the operation switch to "OPER" position.

Presetting of the Controls

POWER switch	: OFF
OPER switch	: STBY
SWR/IP switch	: IP
BAND switch	: Desired band
PLATE Control	: To the number given in the following chart
LOAD Control	: Fully counter-clockwise on number zero

BAND	PLATE	LOADING
80	1—6.5	1.5—5.5
40	6—7	3
20	7—8	3.5
15	9—9.5	4
10	9—10	4.5

Turn the power switch of FL-2100B on and wait for a few seconds for tube warm up. Turn OPER switch onto "OPER" position.

Turn on the exciter and increase the exciter output while not exceeding 0.2 Amps plate current and tune the plate control for dip in the plate current. Alternately adjust the plate and loading controls while increasing the exciter power in small increments until maximum R.F. output occurs at 0.5 Amps plate current. Do not exceed 10 seconds at maximum input to protect the tubes.

To measure relative power output, set the meter switch to "SWR" and "F" (forward) position. If the relative output meter goes off scale during tune up, reduce the meter sensitivity control in a downward direction. Approximate settings of the loading control at maximum input are given in the chart above for 50 ohm load.

Now you are ready for CW and SSB operation.

For SSB operation, the exciter should be adjusted to run the FL-2100B plate current between 0.2 and 0.3 Amps under normal voice operating conditions, because the meter cannot follow speech speed.

For AM operation, tune up the FL-2100B as described previously. Then the exciter should be adjusted to run the FL-2100B at 0.2 Amps plate current with unmodulated carrier.

To measure the SWR of the antenna system, set the meter switch to SWR and apply R.F. power to the antenna. Adjust the meter sensitivity control to read

INTERCONNECTION DIAGRAM

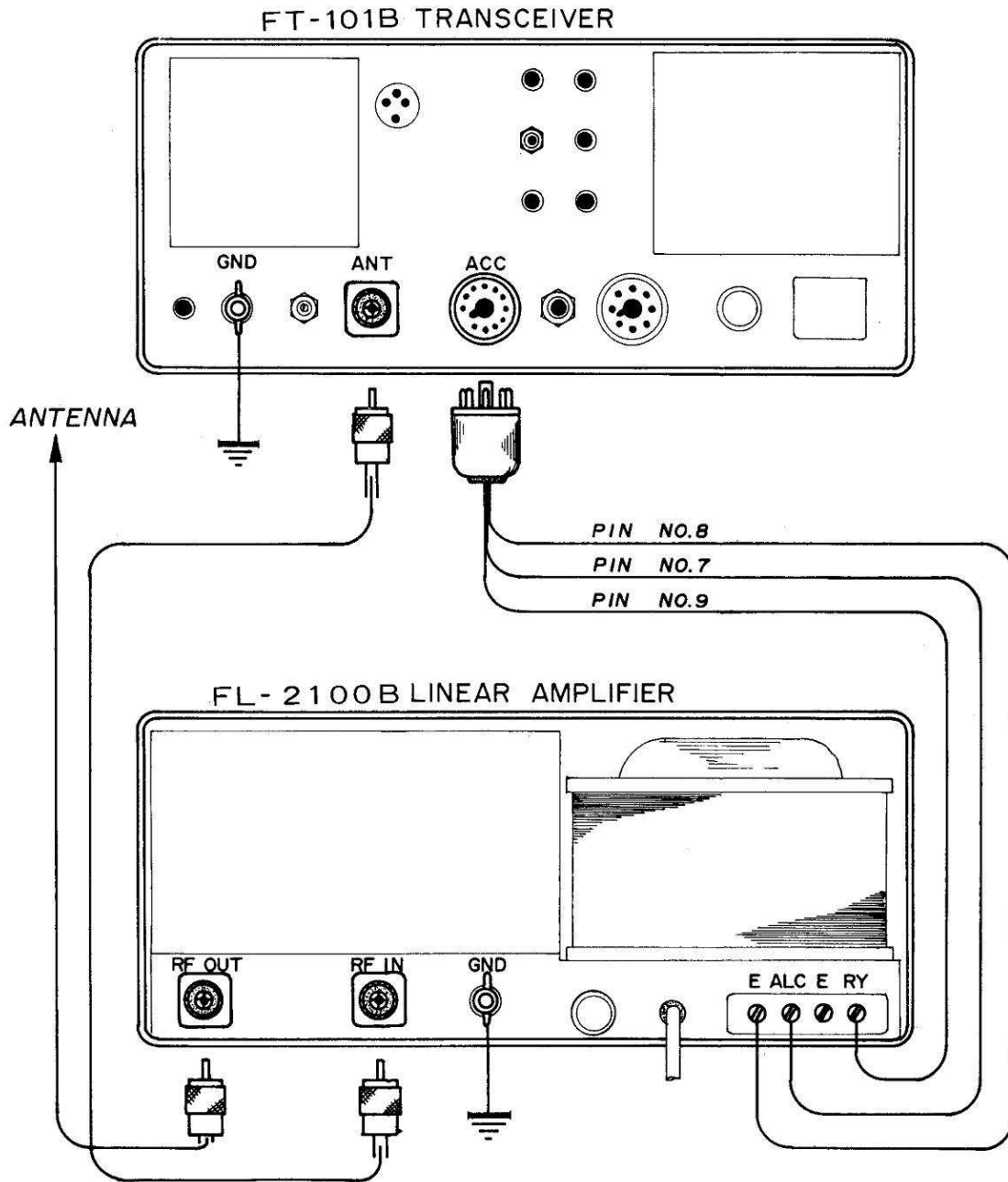

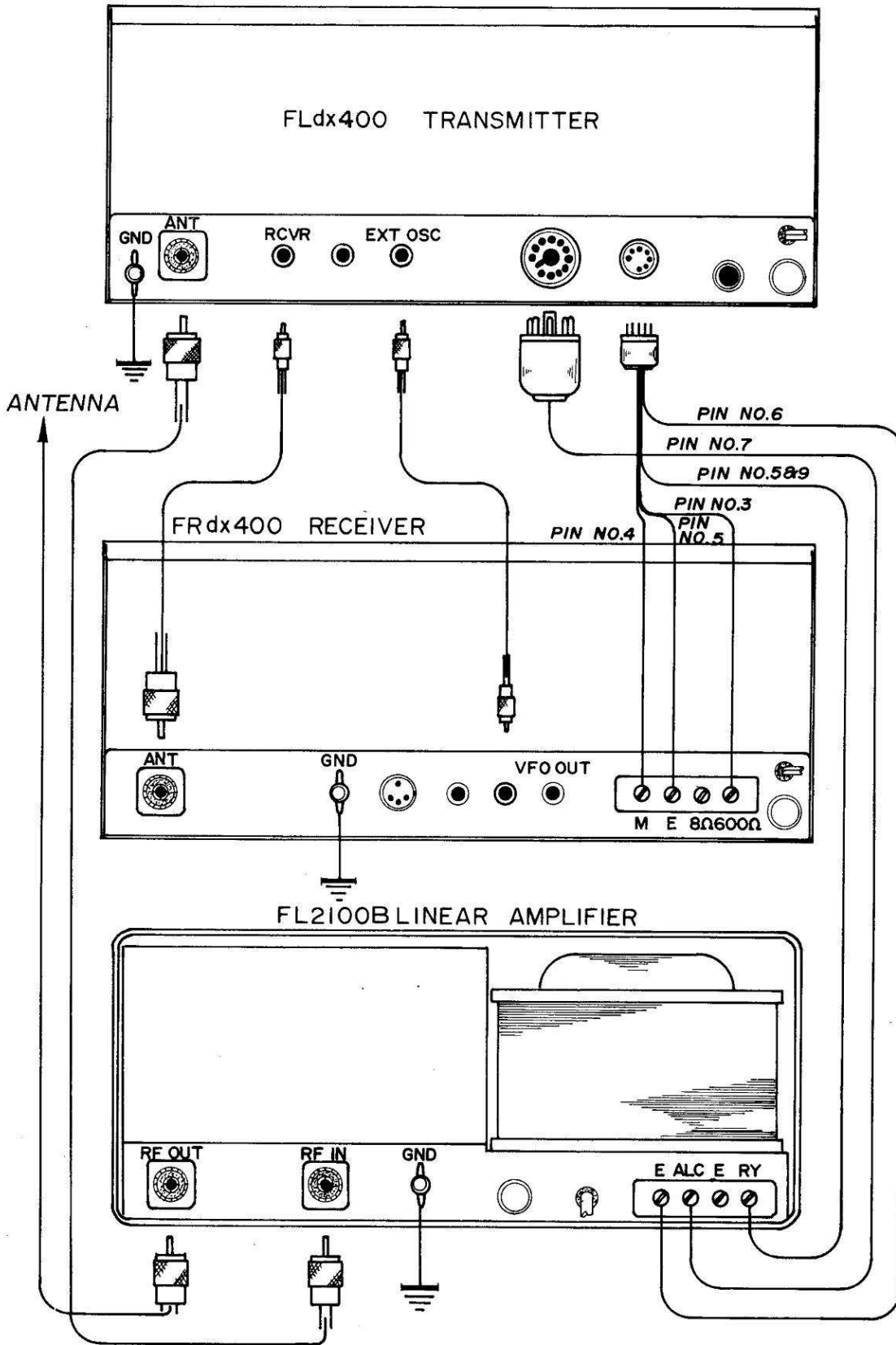

FL-2100B PARTS LIST

C-CAPACITOR				S-SWITCH			
CERAMIC DISC				1 BAND SW.			
1, 2	1.4KV DC	0.01 μ F		2	"	2-4-5	
CERAMIC DISC				3 (POWER) WD 2301			
3, 4, 7, 8, 9	500WV	0.01 μ F	+10%	4	(OPER-STBY)	WD 2301	
205~208, 210, 225			-0%	5	(METER SW)	WD 2101	
ELECTROLYTIC				6 (SWR F-R) WD 2101			
5	25WV	1000 μ F		7	P SAFETY LOCK		
ELECTROLYTIC				F-FUSE			
209	50WV	2.2 μ F		1	AC 100V~117V	20A	
ELECTROLYTIC				AC 200V~234V 15A			
101~106	500WV	100 μ F					
DIPPED MICA				FH-FUSE HOLDER			
201, 202	500WV	200PF	$\pm 10\%$	1	SN-1001		
203	"	5PF	"	PL-PILOT LAMP			
204	"	50PF	"	1, 2	14V 30mA		
CERAMIC				M-METER			
215, 224	TV3K RDA-30	100PF		1	PF-45-1675	1mA/600mA	
212, 217	" "	250PF		2	PF-45-1674	3KV	
211, 216	" "	200PF		FAN			
226	" "	300PF		1, 2	2S10A (FAN)		
221, 222	" "	1000PF		J-JACK			
CERAMIC				2	H, 8P		
223	TV3K RDA-40	500PF		3, 4	JSO-239 (INCH)		
MICA				5	4PC		
213	TV6K	350PF		P-PLUG			
214	"	500PF		3, 4	JPL-259 (INCH)		
219, 220	"	1000PF					
218	"	400PF		VC-VARIABLE CAPACITOR			
R-RESISTOR				201	(PLATE VC)	115PF (MAX)	AIR
101~110	$\frac{1}{2}$ W	470K Ω	$\pm 10\%$	202	(LOADING VC)	430PF $\times 2$	AIR
2	"	2.2K Ω	"	VR-VARIABLE RESISTOR			
204	"	4.7K Ω	"	1, 2	B500 Ω		
201, 202	1 W	33 Ω	$\pm 10\%$	3	B100K Ω		
203	"	3.3K Ω	"	L-INDUCTOR			
5	2 W	1.5M Ω	$\pm 10\%$	1a	TANK COIL		
205, 206	"	22 Ω	"	1b	10 M TANK		
207	"	47K Ω	"	201	GRID RFC		
1, 111~115	"	220K Ω	"	202	80 M INPUT COIL		
VARIABLE				203	40 M "		
4	(BIAS SET)	10W	30 Ω	204	20 M "		
3	M-1	SHUNT		205	15 M "		
V-VACUUM TUBE				206	10 M "		
1, 2	572B/T	160L		207	PLATE RFC		
VS-VACUUM TUBE SOCKET				2	HEATER CHOKE		
1, 2	UX	4P		3	RFC		
D-DIODE				208, 209	PARASTIC COIL		
2, 3, 201	IS 1007			RL-RELAY			
SILICON				1	AW 5221 GK	DC 12V	
1, 202	1S1943 or	SH-1					
101~110	"	10D10					
T-TRANSFORMER							
1	POWER						

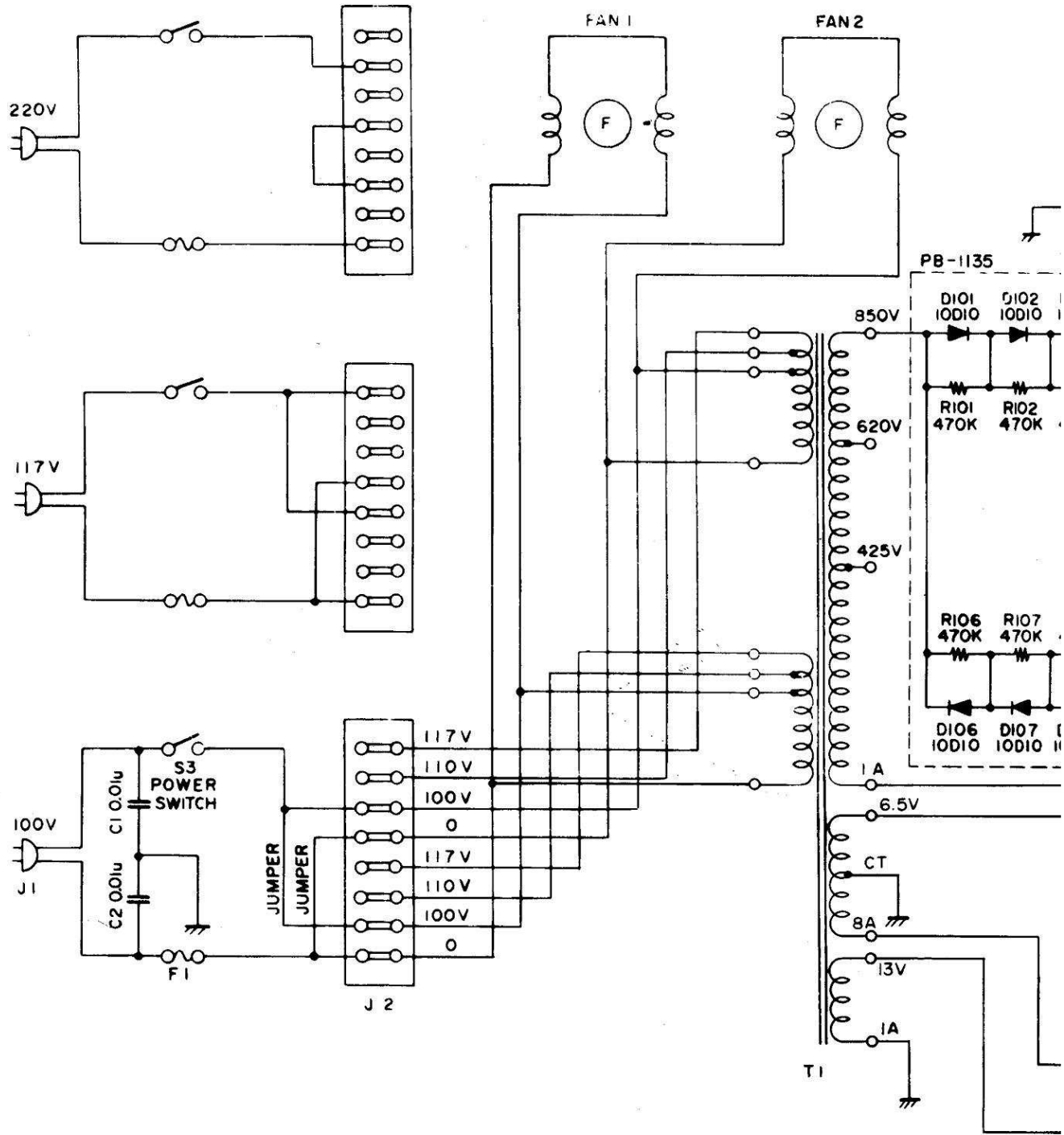

VI 572B / T160L

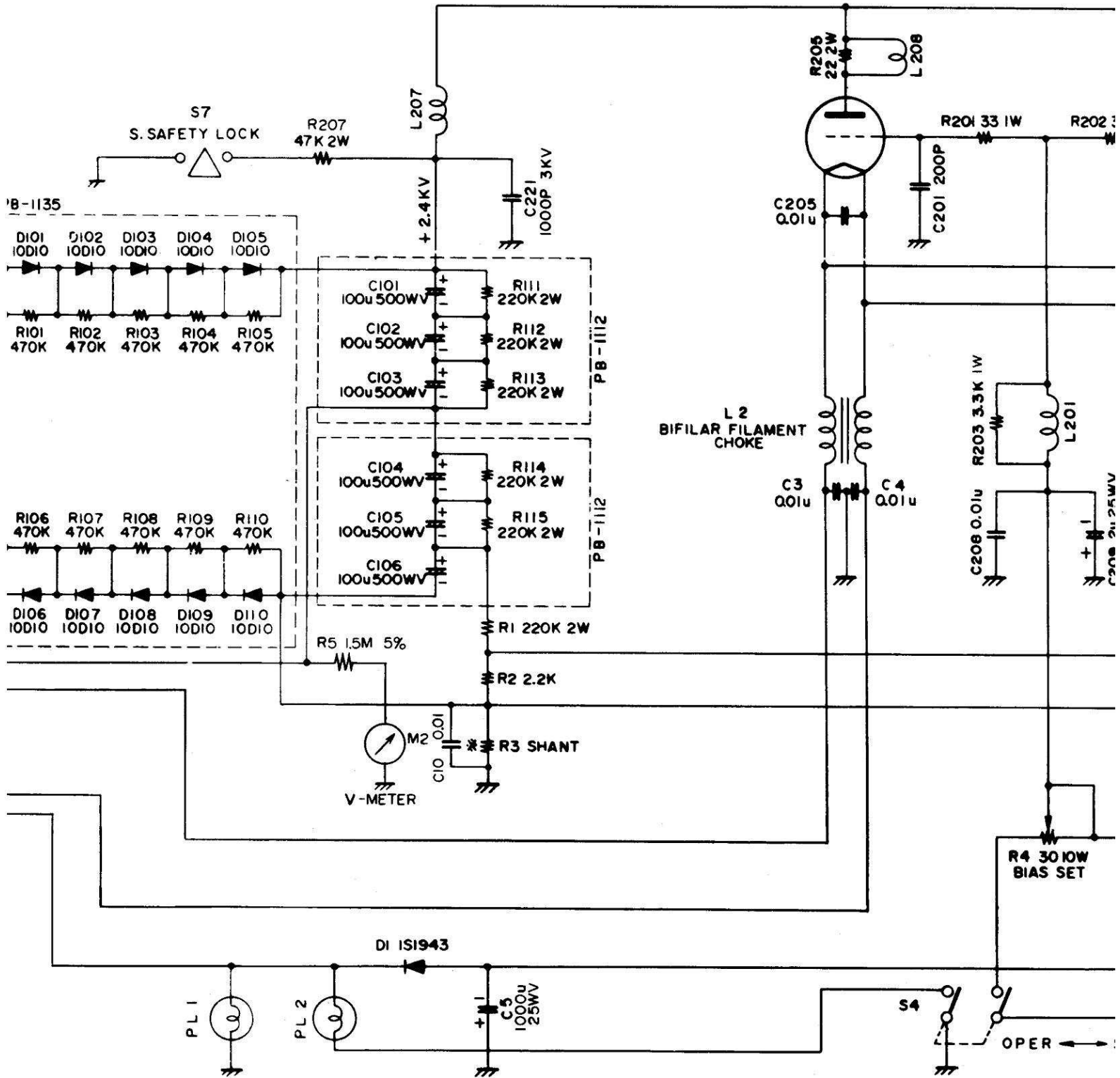

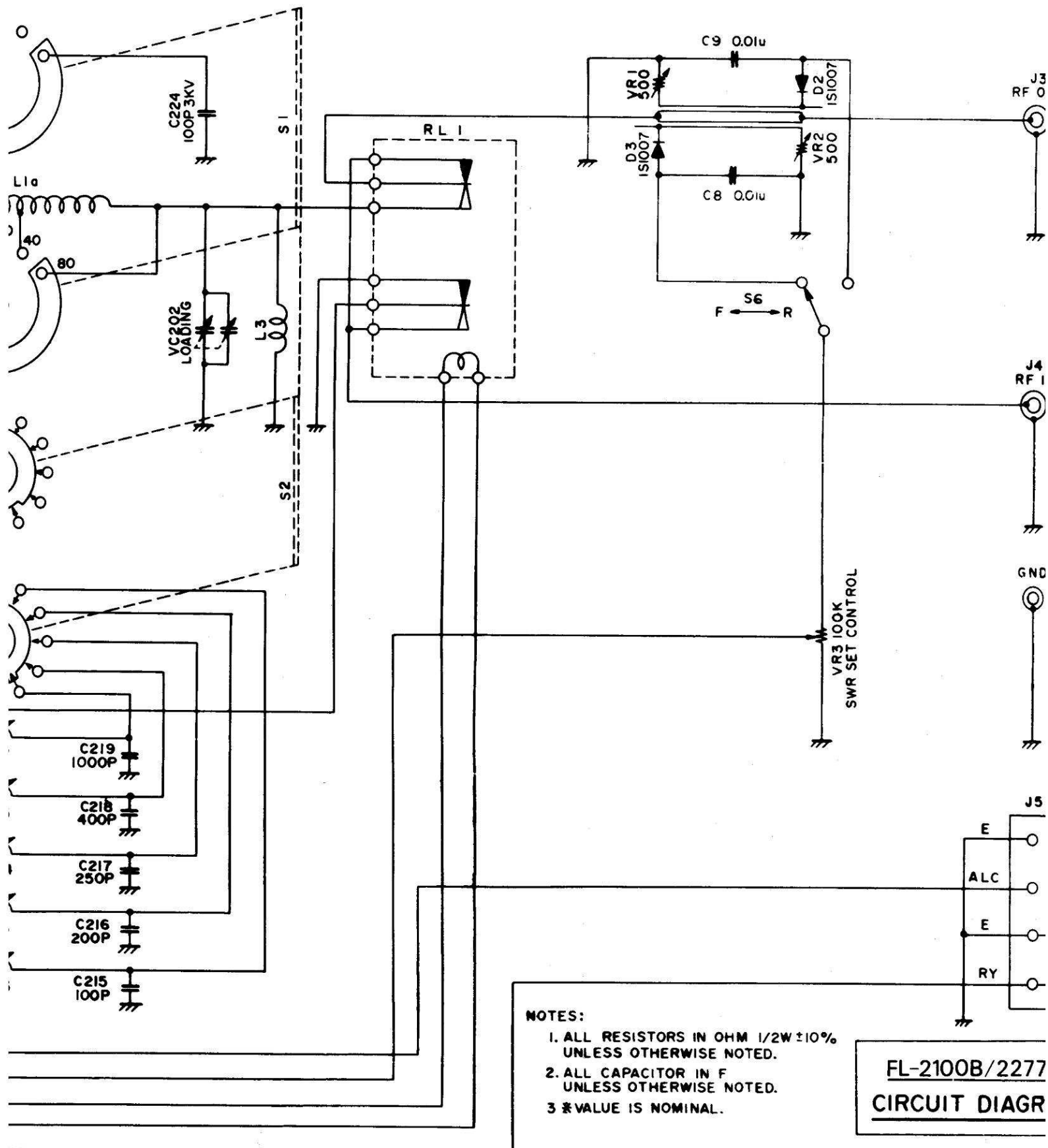

- NOTES:**
1. ALL RESISTORS IN OHM 1/2W ±10% UNLESS OTHERWISE NOTED.
 2. ALL CAPACITOR IN F UNLESS OTHERWISE NOTED.
 - 3 * VALUE IS NOMINAL.

FL-2100B/2277
CIRCUIT DIAGR

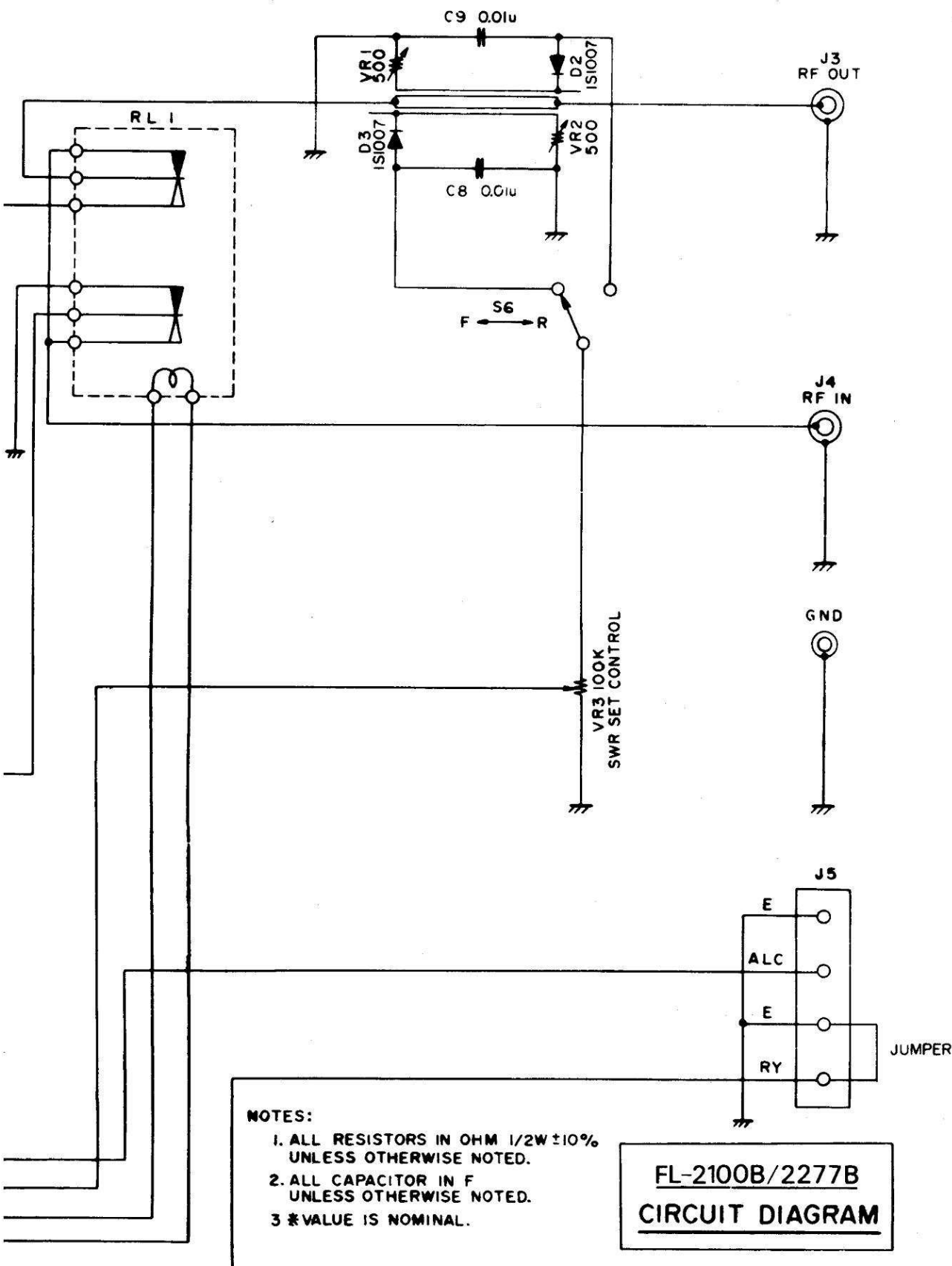

SVETLANA TECHNICAL DATA

572B

High-Mu Power Triode



The Svetlana™ 572B is a high-mu power triode intended for use in class AB, class B and class C RF and Audio amplifiers. The Svetlana 572B features a massive graphite anode for high peak overload capability and a high average plate dissipation of 160 Watts. The Svetlana 572B also features a low loss ceramic base and a bonded-ceramic plate cap thermal insulator for high power RF transmitting tube capability.

The Svetlana 572B has a superior getter system based on titanium adhered to the external surface of the graphite anode. The titanium coating covers the entire anode area extended by the inherent micro surface roughness of graphite. The Svetlana 572B envelope is fabricated from hard glass intended specifically for the high-temperature operation of transmitting tubes.

The internal tube parts are supported by low loss ceramic insulators for high-temperature operation and high voltage hold-off. The internal structure is well supported and is aligned with respect to the base pins to avoid internal shorts in equipment designed for horizontal tube mounting.

The Svetlana 572B may be used as a direct drop-in replacement in equipment designed for the 811A, T160L or 572B.

Characteristics

Electrical	
Filament:	Thoriated-tungsten
Voltage (AC or DC)	6.3 V ± 0.3V
Current	4 A
Amplification factor (average)	170
Direct interelectrode capacitances:	
Grid to plate	6.0pF
Grid to filament	5.9 pF
Plate to filament	0.8 pF
Maximum frequency for full ratings	30 MHz
Mechanical	
Cooling	Radiation and forced air
Base	Ceramic, standard small four pin
Plate cap	Standard medium cap 14 mm dia. with ceramic thermal insulation
Plate connector	Svetlana PC-1A or equivalent
Socket	Svetlana SK4A, Standard small, four contact
Operating position-Axis vertical, base down or horizontal w/ pins 1 and 4 in vertical plane	
Nominal dimensions:	
Diameter	45.7 mm (1.8 in.)
Base to plate cap	147.3 mm (5.8 in.)
Overall height	162.6 mm (6.4 in.)
Net weight	113 gm

Linear RF Power Amplifier, Class B Grounded Grid, Maximum ratings

	ICAS*
DC plate voltage	2750 V
DC plate current	275 mA
Plate dissipation	160 W
DC Plate input	600 W
DC Grid current	50 mA

*Intermittant commercial and amateur service

Svetlana Outline drawing

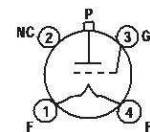
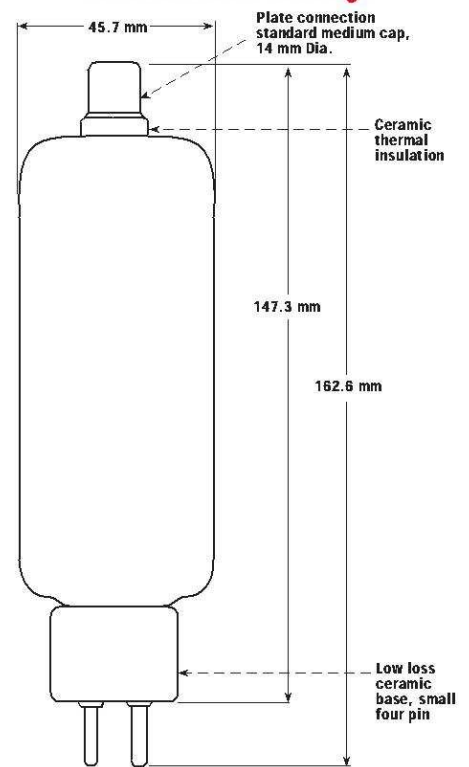

Base pin connections, bottom view

Notes:

The internal structure is aligned with respect to the base pins to avoid internal shorting problems in equipment designed for horizontal tube mounting.



Svetlana
ELECTRON DEVICES

Headquarters:
8200 South Memorial Parkway
Huntsville, AL 35802
USA
Phone: 205 882 1344
Fax: 205 880 8077

Marketing & Engineering:
3000 Alpine Road
Portola Valley, CA 94028
USA
Phone: 415 233 0429
Fax: 415 233 0439

www.svetlana.com

Svetlana 572B High-Mu Power Triode



Svetlana
ELECTRON DEVICES

Typical Operation, Grounded Grid Linear Amplifier

(frequencies to 30 MHz)	ICAS**	
DC plate voltage	2400	V
DC grid voltage	-2	V
Zero-signal DC plate current **	45	mA
Single-tone DC plate current	250	mA
Driving power	50	W
Single-tone useful output power **	300	W

** Approximate value

Mechanical Application

Mounting: The Svetlana 572B may be operated with its axis vertical and the base down, or horizontally with pins 1 and 4 in a vertical plane.

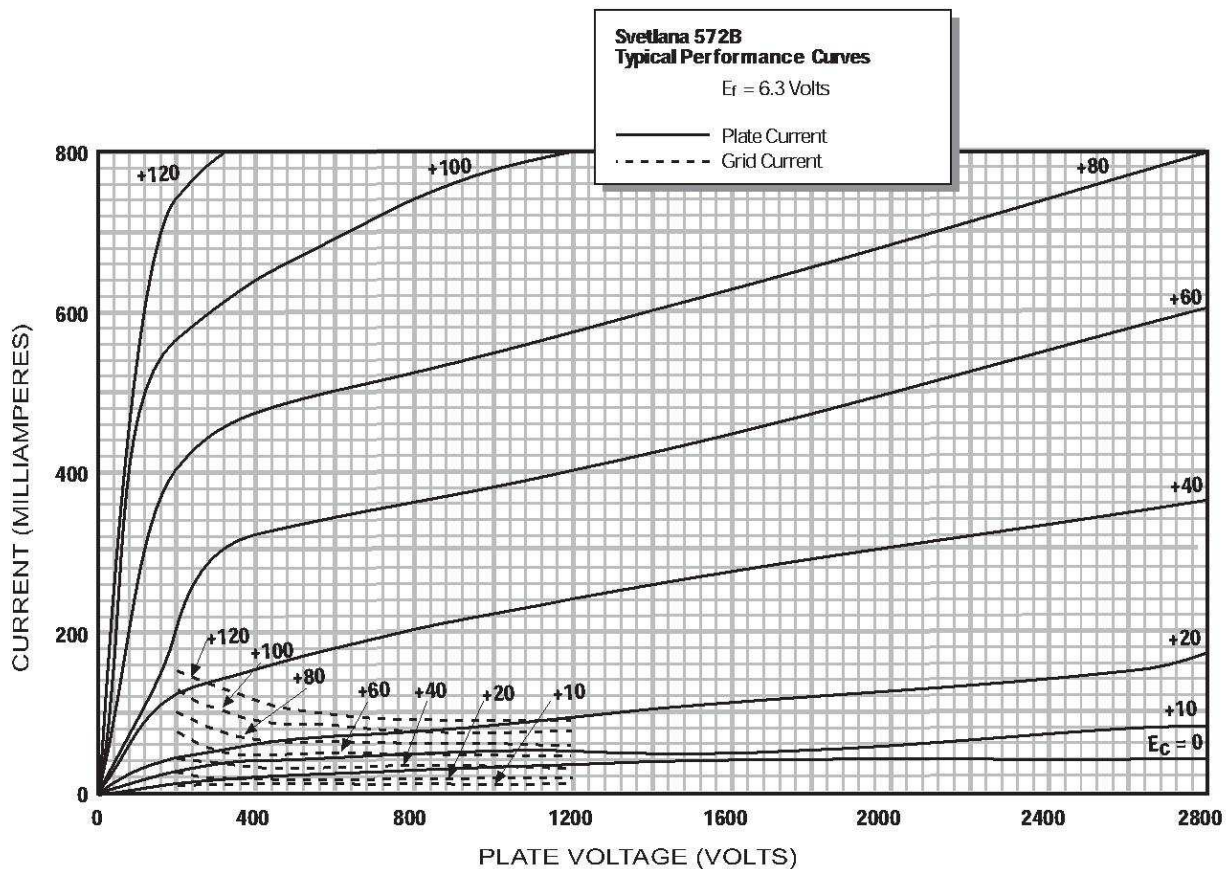

Versions of the 572B designed for audio amplifier service are available.
Ask for SV572 Series data.

No.15
Amateur Radio
572B

TECHNICAL BULLETIN

TECHNICAL TOPICS

Article as first appeared in RadCom Magazine

(October 1996)



A letter from George Badger, W6TC, of Svetlana notes that the Yaesu FL-2100 series of linears, using the 572B high-mu high-power triode, has proved very popular in the UK. He points out that the new Svetlana 572B has slightly higher gain than the original. When fitted in the FL-2100, FL-2100B, FL2100B and FL2100F linears they sometimes oscillate in the standby mode because, as Yaesu has confirmed, the cut-off bias is only slightly higher than cut-off. If the amplifier 'takes off' as an unloaded TPTG oscillator it can wreak havoc.

W6TC bought a used FL-2100B and modified the bias circuit: **Fig 5** shows the original arrangement and **Fig 6** the modification, incorporating a voltage-doubler configuration to increase the stand-by cut-off bias. After modification, the amplifier becomes unconditionally stable when fitted with the higher-gain Svetlana

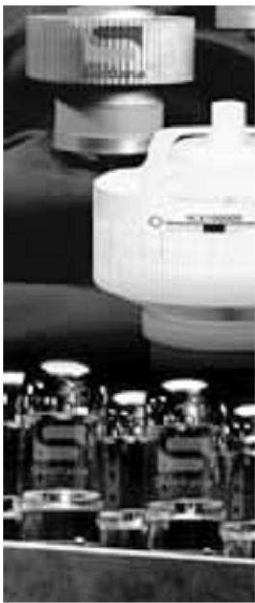

572B.

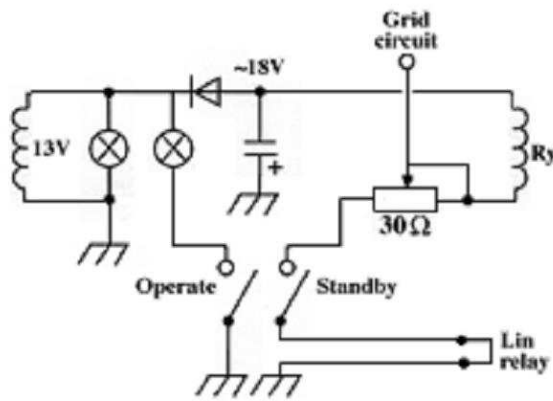

Fig 5: Stand-by bias arrangement as used in the Yaesu FL-2100B linear amplifier.

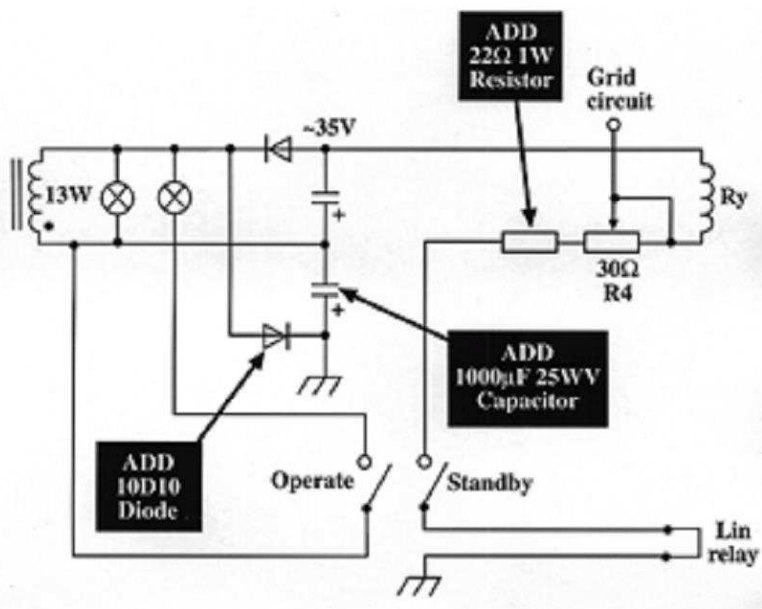

Fig6: How W6TC modified the stand-by bias in his FL-2100B to increase the bias voltage by using a voltage-doubler arrangement in order to ensure unloaded stability when the higher-gain Svetlana 572B valve is fitted.

The Heathkit SB-200 which uses a similar circuit has 100V cut-off bias and is stable when fitted with the Svetlana 572B. This applies also to the new Yaesu FL-2100Z.

The Svetlana 572B features a massive graphite anode for high peak overload capability and an average anode dissipation of 160W. Typically, as a linear Class B grounded-grid amplifier with 2.4kV HT and 50W drive, it can provide a single-tone useful output power of about 300W. It can be used as a drop-in replacement for the 811A to provide up-graded performance.

