

**INSTRUCTION
MANUAL
FOR**

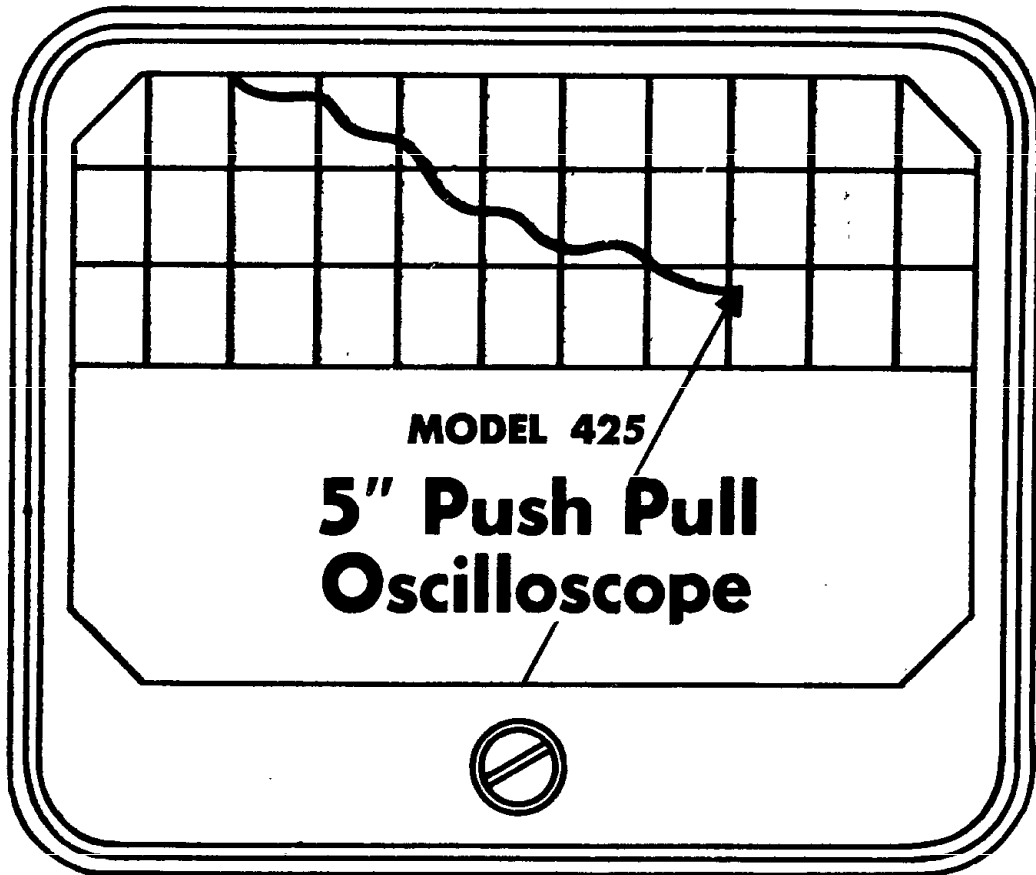

EICO

**ELECTRONIC
INSTRUMENT CO., Inc.**

INSTRUCTION BOOK
MODEL 425 OSCILLOSCOPE

GENERAL DESCRIPTION

The EICO Model 425 Oscilloscope has been designed to meet a definite need in the radio and television industries. It has the features of the general purpose oscilloscope, an instrument for the analysis of current and voltage waveforms, plus an extended range of frequency, sweep and sensitivity. It may also be used to study any variable within the limits of its frequency response and characteristics.

SPECIFICATIONS

1. Power Consumption: 68 watts, 100-130 volts, 50-60 cycles. Both sides of line fused.
2. Cathode Ray Tube: 5BP1 or equivalent.
3. Amplifiers: Push-Pull

Vertical

Horizontal

Sensitivity:

.05-1 RMS Volts/inch

.05-15 RMS Volts/inch

Frequency Response:

5 cycles to 400KC
cycles

5 cycles to 400KC
cycles

Usable to 2.5mc with
full gain setting.

Maximum Input Voltage:

400 Volts

400 Volts

4. Horizontal Time Base: 15 cycles to 75,000 cycles (Multivibrator)
5. Intensity Modulation: At back panel
6. Test Signal: 6.3 volts, 60 cycles, front panel.
7. Tube Complement: 1- 5BP1 Cathode Ray Tube
2- 6SN7 Amplifiers
1- 6SN7 Multivibrator

- 1- 5Y3 Low Voltage Rectifier
- 1- 5Y3 High Voltage Rectifier
- 2- 6J5 Amplifiers
- 8. Dimensions: 15" High (including 1½" handle)
8 7/8" wide, 17 3/4" deep.

Rack Mounting: 13" High, 8 7/8" Wide,
17 3/4" Deep.

- 9. Weight: 30 Pounds

OPERATING INSTRUCTIONS

The controls for operating the oscilloscope are listed below:

1. INTENSITY: adjusts the brilliance of the trace. Note: use as low an intensity setting as possible. This will lead to a sharper picture.
2. FOCUS: makes the trace sharp and clear.
3. POSITIONING CONTROLS: locates the trace on the desired portion of the screen.
4. COARSE FREQUENCY: sets the approximate frequency of the horizontal sweep. When the knob is set between two numbers, the fine frequency control will vary the frequency from the lower value to the higher value.
5. FINE FREQUENCY: varies the sweep throughout the range shown on the coarse frequency.
6. SYNC. AMP: The synchronization amplifier is used to lock the horizontal sweep to the frequency being observed. Note: Use as little synchronization as possible since too high a setting tends to distort the picture.

7. GAIN CONTROLS: adjust the amount of internal amplification necessary to obtain a normal trace on the screen. Note: Too much amplification can cause distortion of the picture. Therefore, for normal use, adjust the amplifiers for a little less than full scale deflection.
8. SYNC. SWITCH: switches the horizontal synchronization from internal sync to the EXT. SYNC. jack on the front panel.
9. HORIZONTAL INPUT SWITCH: connects the horizontal amplifiers to either the internal sweep generator or the horizontal input binding post.
10. INTENSITY MODULATION JACK: is located on the rear panel and is used to provide sweep blanking or timing on the trace.
11. VERTICAL DEFLECTION PLATES (DIRECT): may be used by connecting to the terminal strip on the rear panel. Here the amplifiers are bypassed and the scope may be used as either a DC or AC vacuum tube voltmeter by the simple calibration of the screen. This position is also extremely valuable in checking the modulation patterns from a transmitter.

NOTE: When adjusting the scope, never leave a small spot or an excessively bright trace on the screen for any length of time. The high velocity electrons when concentrated in a small area will burn or otherwise shorten the life of the fluorescent material upon the tube face.

GENERAL OPERATION

When first turning on the oscilloscope, place the horizontal input switch on the sweep position, the horizontal gain to about $\frac{1}{2}$, the intensity and focus controls almost full on, and rotate the positioning controls until the trace comes into view.

To see a sine wave, connect a short piece of wire from the 60 cycle test binding post to the vertical input post. Adjust the vertical gain so the picture covers most of the screen. Set the coarse frequency from 15-75 and adjust the fine frequency control until the single wave or two waves are almost stationary. Switch to INTERNAL SYNC and apply just enough SYNC AMP to stop the picture.

Never use a higher setting of the SYNC AMP control than is necessary or the image may be distorted.

When using the intensity modulation, never apply enough signal to drive the grid positive with respect to the cathode. This shortens the life of the tube.

All signals to the oscilloscope from external sources require two wires. One carries the signal and the other grounds the chassis.

HOW A CATHODE RAY TUBE WORKS

A prerequisite to understanding the oscilloscope is to have a knowledge of the CRT. Consider Figure 1, which is a somewhat simplified diagram of a cathode ray tube.

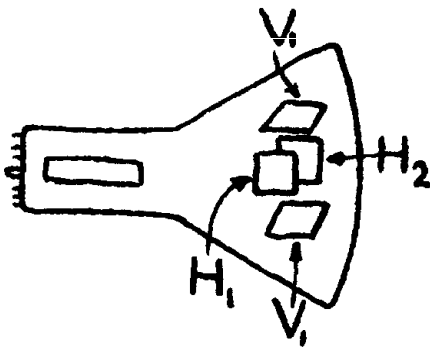

FIGURE 1

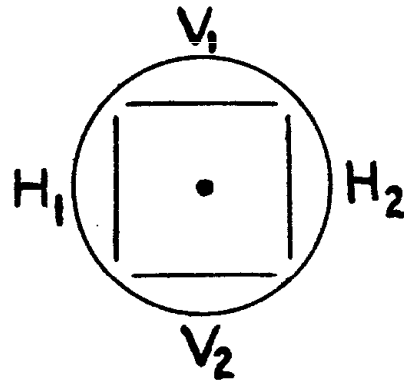

FIGURE 2

In the electron gun, a cathode emits electrons which, due to the high potentials in the gun, are given sufficient velocity to reach the screen. When electrons impinge upon a fluorescent material, it becomes luminous at that point. This then is the reason why a television tube (kinescope) or CRT emits light. Also in the CRT are two sets of metallic plates between which the electrons pass on their way to the fluorescent screen. Remembering that electrons are inherently negative and that opposites attract and likes repel, we can develop the purpose of these plates. Looking in at the face of the tube, as shown in Figure 2, we would see the fluorescent screen, the plates and the white dot caused by the electron beam. If now we applied a positive voltage to plate H1 and a negative voltage to plate H2; H1 would attract the beam, H2 would repel it and the beam would move over somewhat closer to H1. Therefore the dot of light would be displaced to the left. Conversely, if the reverse voltages were applied to the plates the beam would move to the right.

If now an alternating current were applied, the beam would continuously deflect from one side to the other. If that current were made to change quickly enough, the result would be a horizontal bar.

In order to see the shape of an input signal on the screen, a sawtooth wave is applied to the horizontal plates and the waveform, which is to be observed, on the vertical plates.

Consider figure 3. If this sawtooth wave were applied to the horizontal plate H2, the beam would be all the way to the left at point 1 and would gradually come to the center at point 3 and finally all the way to the right at point 5.

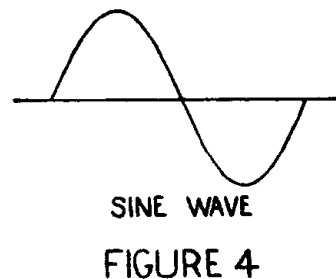
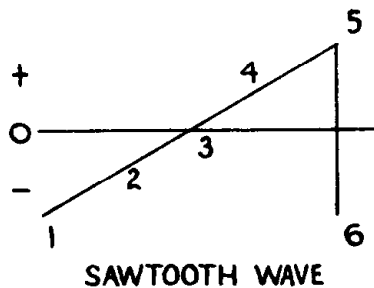

From point 5 to point 6 the beam would again be returned to the left side of the screen. The return, however, would be very much faster than the comparatively slow change from 1 to 5. If now a sine wave, figure 4, was placed on the vertical plates, the overall effect would be that of figure 5.

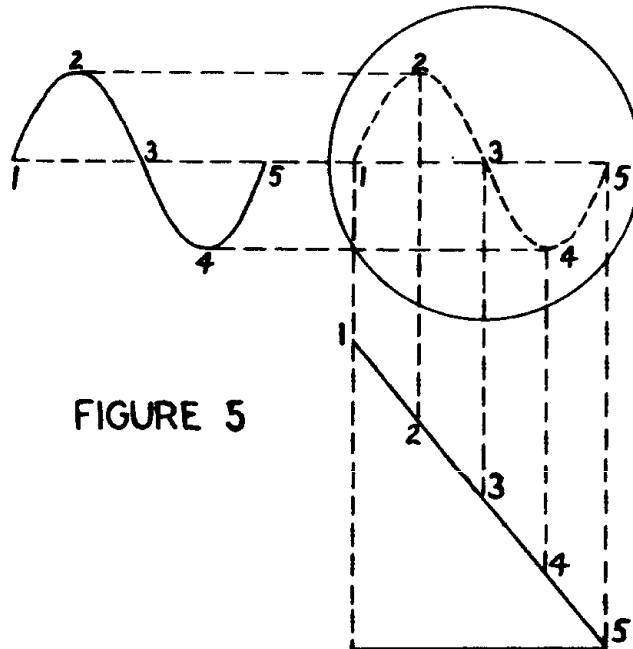

FIGURE 5

At point 1, the horizontal voltage would bring the beam all the way over to the left. Since there is no voltage on the vertical plate at time 1, the beam would remain there for that instant.

At point 2, the horizontal voltage would not be as great and therefore the beam would not be deflected as far to the left as it was before. At this point however, the voltage on the vertical plate V-1 would carry the beam upward and the resultant at that instant would be point 2 on the screen. Following this procedure and then connecting all the points, the resultant picture on the screen would be that as shown by the dotted lines.

If now any wave form were applied to the vertical plates, that wave form would be identically reproduced on the screen.

LISSAJOUS FIGURES

It is often necessary in electronics to measure the frequency of an unknown sinewave. This may readily be accomplished by applying a known sine wave to one of the plates and the unknown to the other.

As an example let us consider the case where a 60 cycle wave is applied to the vertical plates and a 180 cycle wave is applied to the horizontal plates, see figure 6.

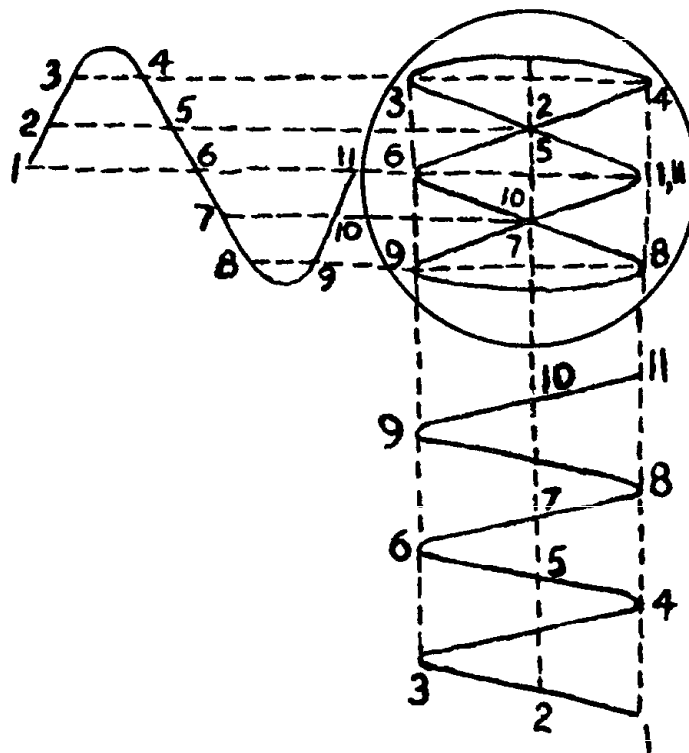

FIGURE 6

By plotting one against the other the resultant would be that as shown. Note one very important factor: the number of loops is 3. The ratio of the frequencies is also 3. If the ratio of the frequencies were 4, the number of loops would be 4. Therefore, by simply counting the number of loops and multiplying by the known frequency the unknown frequency may be determined.

If both signals were of the same frequency and they were in phase, the resultant would be a straight line. If they were the same frequency and 90 degrees out of phase, a circle would result.

MODULATION PATTERNS

A very common and important measurement with transmitters is that of Percent Modulation. This may be accomplished very readily by feeding a portion of the modulated radio frequency signal directly into the vertical deflection plates and the audio signal which caused the modulation into the horizontal amplifier. The resultant pattern would be somewhat like that shown in Figures 7A, 7B, 7C or 7D. The formula is:

$$\text{Modulation \%} = (1 - h_2/h_1)100$$

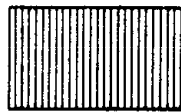

0%

FIGURE 7A

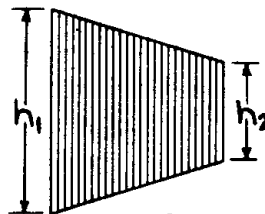

50%

FIGURE 7B

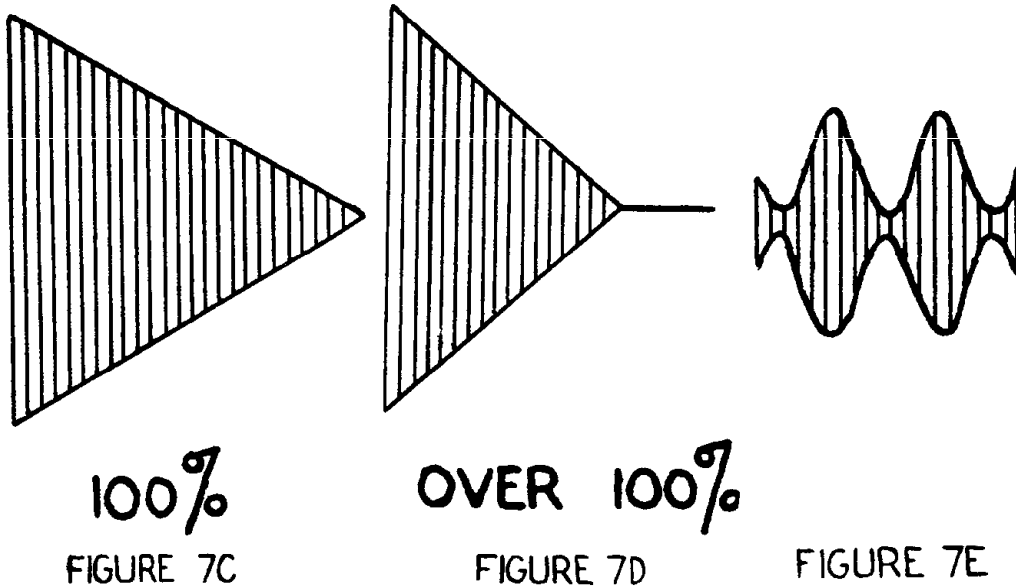

A 100% modulated R.F. wave as observed with the conventional sawtooth sweep is shown in Figure 7E.

To connect directly to one of the vertical deflection plates, remove the jumper from either of the two end terminals at the back of the scope and connect to the inside terminal, see Figure 8A. If both plates are to be used, remove both jumpers and connect to both inside terminals. Note: Replace jumpers for normal operation. Figure 8B is an example of the hookup necessary to develop the modulation pattern.

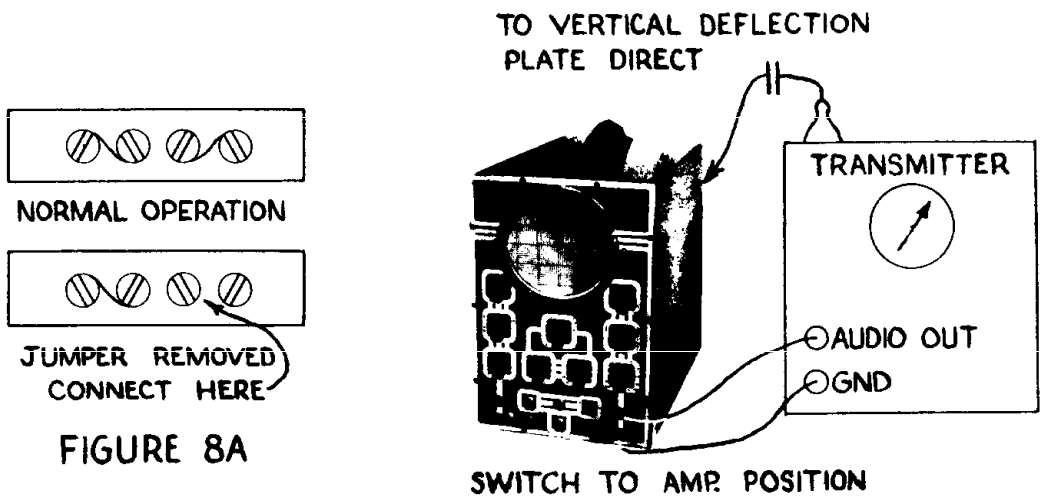

FIGURE 8A

FIGURE 8B

VISUAL FM RECEIVER ALIGNMENT

The equipment necessary for the alignment of an FM receiver, or the sound portion of a television receiver, is a sweep generator, such as the EICO Model 360 and an oscilloscope. Spurious signals, such as might be picked up by the antenna, are eliminated by shorting out the antenna terminals with a piece of wire. The oscillator in the FM receiver which might cause beats is disabled by either removing the tube, if feasible, or by shorting out the oscillator coil with a .01 mfd condenser.

For the discriminator alignment, the vertical lead from the oscilloscope is connected across the output of the discriminator, point B figure 10A. The generator is tuned to the discriminator frequency and this signal is fed directly to the grid through a .001 mfd condenser. The sweep voltage from the generator is fed to the horizontal amplifier of the oscilloscope, Figure 10B.

The primary of the discriminator is aligned for maximum height while the secondary is aligned for the well known "S" curve, see Figure 9A

To align the IF section, the oscilloscope lead going to the output of the discriminator is now shifted to the grid load of the limiter tube, point A on Figure 10A. Adjustment of the various IF transformers should yield an IF response curve as shown in Figure 9B.

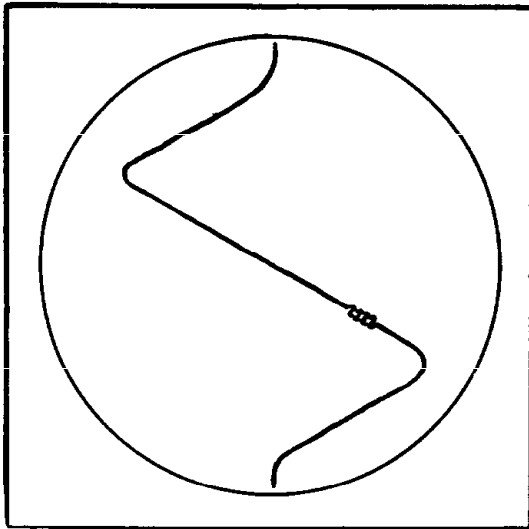

F-M DISCRIMINATOR I.F.
RESPONSE CURVE WITH
MARKER PIP

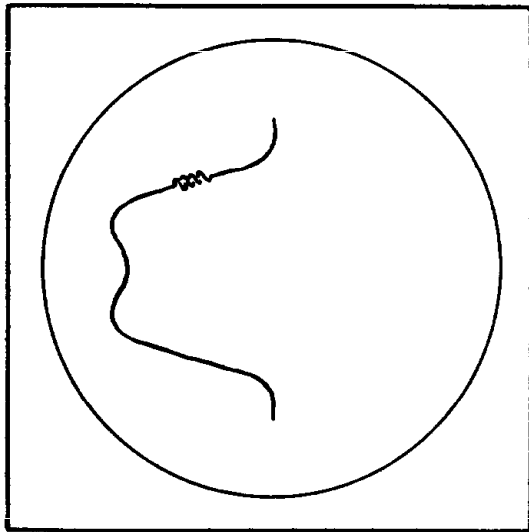

TYPICAL F-M I.F. RESPONSE
CURVE WITH MARKER PIP

FIGURE 9A

FIGURE 9B

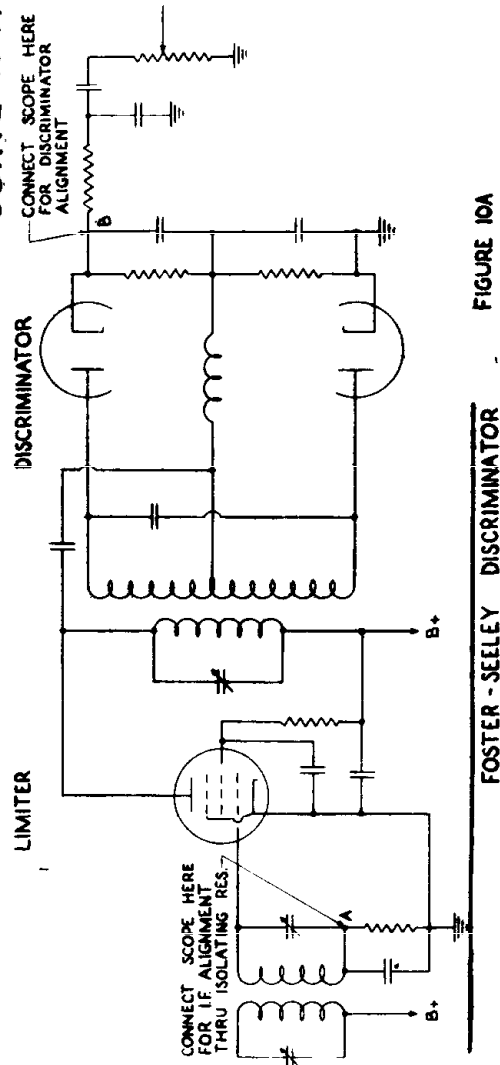
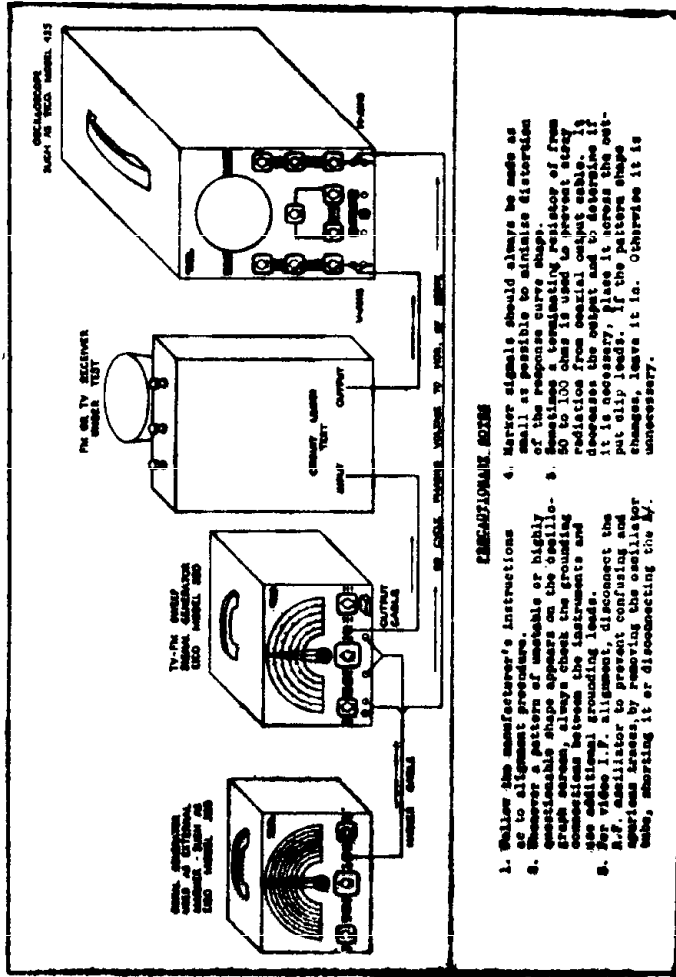

FIGURE 10A

FOSTER - SEELEY DISCRIMINATOR



PRECAUTIONS

1. Follow the manufacturer's instructions as to alignment procedure.
2. Whenever a pattern of unstable or highly questionable shape appears on the oscilloscope screen, always check the grounding connections to the instrument and use additional grounding leads.
3. For video I.F. alignment, disconnect the A.F. oscillator to prevent confusing and spurious traces, by removing the oscillator tube, moving it or disconnecting the A.F. tube.
4. Marker signals should always be made as small as possible to minimize distortion of the response curve shape.
5. Sometimes a terminating resistor of from 50 to 100 ohms is used to prevent stray reflections on the test leads. If it decreases the signal amplitude, it is unnecessary. If the pattern shape changes, leave it in. Otherwise it is unnecessary.

FIGURE 105

TYPICAL SETUP FOR VIDEO ALIGNMENT WITH E.C.O. OSCILLOSCOPE

28 5 22

GUARANTEE
 This instrument is guaranteed to be free from defects in material and workmanship in accordance with the terms of the Standard RCA Warranty.

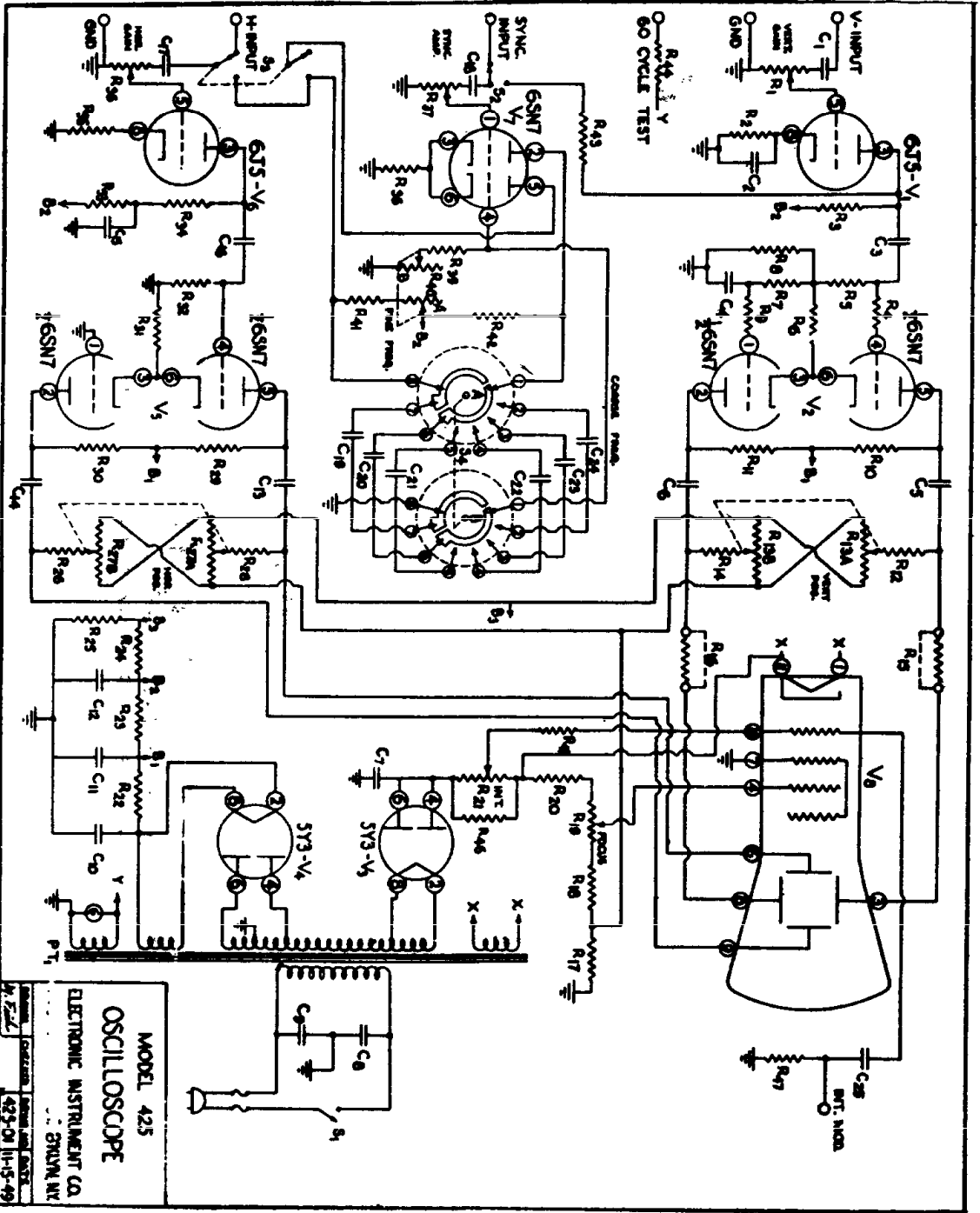

MODEL 425
 OSCILLOSCOPE
 ELECTRONIC INSTRUMENT CO.
 SYLVAN, N.Y.

425-01 (1-15-49)