



Phone: (714) 433-1983
TWX: 910-322-1397

417 Via Del Monte
Oceanside, Ca. 92054

SERVICE BULLETINS

TO: Service Manager
FROM: Atlas Radio, Inc.
SUBJECT: Service Bulletins
DATE: April 4, 1977

Enclosed you will find several instructions on the various adjustments and alignment procedures for the Atlas 210X/215X. We feel that these should be very helpful in dealing with some problems that may be encountered by your customers. As always, if you ever have any questions regarding these instructions or anything else, please don't hesitate to contact us.

73,

ATLAS RADIO, INC.

Clint Call
Clint Call, W60FT
Customer Service Manager

CC:lah

Atlas Service Bulletins

Contents

Transmitter Input Filter Adjustment

Filter Roll-Off Adjustment Procedure

VFO Dial Alignment

ALC Adjustment

Receiver Input Filter Adjustment

Carrier Null (Suppression) Adjustment

Power Amplifier Bias Adjustment

S-Meter Adjustment Procedure

High-SWR Protection Circuit Adjustment for 210X

Modifying the Atlas 210 for Amplitude Modulation
(AM) Transmission

How to Convert the Atlas 210X for Citizen's Band
Reception

Atlas Transceivers, Mobile Installation Notes

Model 200-PS Portable Supply

TRANSMITTER INPUT FILTER ADJUSTMENT

Equipment Required

- 1 Audio Signal Generator
- 2 Dummy Load Wattmeter
- 3 PC Board Right Angle Adaptor
- 4 Power Supply Extender Cable or 200PS
- 5 200 ohm Resistor

Procedure

- 1 Remove top cover of transceiver.
 - 2 Remove PC-100 (or PC-120) Board from edge connector and reinsert, using PC Board Right Angle Adapter. This allows access to PC-900 Trimmer Capacitors.
- CAUTION: Be sure to reinsert PC-100 (or PC-120) such that pin one makes to pin one, etc. Reversal of the board will cause severe damage to chassis wiring.
- 3 Connect Dummy Load Wattmeter to antenna output connector.
 - 4 Connect power to transceiver using power supply extender cable.
 - 5 Connect audio signal generator to mike input receptacle and adjust to 1500 cycles at .03 VAC.
 - 6 Place bandswitch in lowest band (see note two).
 - 7 Jumper C901 on PC-900 board, using 200 ohm resistor. (see note three)
 - 8 Tune transceiver to center of band.
 - 9 Place function switch in Trans and advance mike gain control fully clockwise.
 - 10 Adjust C902 for maximum indication on Wattmeter.
 - 11 Place function switch in REC.
 - 12 Remove jumper resistor from C901 and jumper C902.
 - 13 Place function switch in Trans and adjust C901 for maximum indication on wattmeter.
 - 14 Place function switch in REC. The lowest band is now properly adjusted.
 - 15 Using the above procedure, adjust each pair of trimmers in turn for their appropriate band. (see note one)

Note 1:

The jumper resistor need only be used on 7 MHZ band and below.

Note 2:

Later model sets use fixed components on 7 MHZ bands and below and tuning is only needed on 14 MHZ band and above.

Note 3:

The correct pair of trimmers can be located easily, by tracing the connections from the band switch section nearest the PC-900 Board.

FILTER ROLL-OFF ADJUSTMENT PROCEDURE

Equipment Needed

- 1 Audio Signal Generator with output adjustable to .03 VAC
- 2 Dummy Load Wattmeter
- 3 Power Supply Jumper Cable, or 200PS

Procedure

- 1 Remove bottom cover plate of transceiver.
- 2 Connect power, using jumper cable.
- 3 Connect output of Audio Generator to Mike Input receptacle.
- 4 Set Side Band selector switch to Norm.
- 5 Set Band switch to lowest band.
- 6 Set Audio Generator to 1500 CPS at .03 VAC.
- 7 Place transceiver in Xmit, and advance Mike Gain setting until output is 40 W.
- 8 Without disturbing Mike Gain setting, readjust Audio Generator to 300 CPS at .03 VAC.
- 9 Adjust C603* (located on Carrier Osc. board) until output reads 10 W.
- 10 Switch Sideband selector switch to Opp and adjust C602* until output reads 10 W.
- 11 Reset Audio Generator to 1500 CPS at .03 VAC and check that output reads 40 W in both Norm and Opp positions of sideband selector switch.
- 12 Repeat steps 6 through 12 as necessary.

Roll-off will now be set correctly.

73,

Clint Call W6OFT
Customer Service Mgr.
ATLAS RADIO, Inc.

* Early operating manuals designate these as C607 and C608, respectively.

VFO DIAL ALIGNMENT

Equipment Required

- 1 Power Supply Extender Cable or 200PS
- 2 DD-6 Digital Dial or Signal Generator

Procedure

- 1 Remove top cover of transceiver to permit access to VFO trimmer capacitors, which are located along the right side of the dial drum.
NOTE: On earlier sets the trimmer capacitors are reached through holes in the VFO cover plate under the bottom cover of the transceiver.
- 2 Connect power to transceiver using power supply extender cable.
- 3 Rotate tuning knob until dial indicates exactly 200 * and set Dial Set to center position.
- 4 Place function switch in Rec. and connect DD-6 Digital Dial.
- 5 Place bandswitch in desired band and adjust corresponding trimmer capacitor** until DD-6 indicates exactly as dial indication

73,

Clint Call W6OFT
Customer Service Mgr.
ATLAS RADIO, INC.

* On model 215 and 215X, the 160 meter band (1.8 MHz) should be aligned with the dial set at 1800.

** The frequency is normally printed adjacent to the trimmer capacitor; if it is not the lowest frequency band trimmer is located nearest the front panel and the next higher band trimmer just behind it, etc.

NOTE: If using RF signal generator in lieu of DD-6, adjust trimmer capacitor to zero-beat with signal generator.

ALC ADJUSTMENT

Equipment Required

- 1 Audio Signal Generator
- 2 Dummy Load
- 3 VTVM
- 4 Power Supply Extender Cable or 200PS

Procedure

- 1 Remove the top cover of the transceiver.
- 2 Remove the shield which is fastened to the metal bracket which supports the receiver input tuning coils and to the rear lip of the chassis. (This permits access to the ALC trimmer capacitor which is located in the now exposed groove, just to the right of center.)
- 3 Connect the dummy load to the antenna connector.
- 4 Connect the Audio Signal Generator to the mike input receptacle and adjust it for 1500 cycles at .03 VAC.
- 5 Connect power to the transceiver using power supply extender cable.
- 6 Place the bandswitch in the highest band.
- 7 Connect the +DC probe of the VTVM to the accessible lead of the 1000 ohm resistor which is to the right and forward of the ALC trimmer capacitor and set the VTVM on its most sensitive scale.
- 8 Place the function switch in Trans and advance the mike gain control until the VTVM reads about mid-scale.
- 9 Adjust the ALC trimmer capacitor until a minimum reading is obtained on the VTVM. The ALC circuit will now be properly adjusted.

73,

Clint Call W6OFT
Customer Service Mgr.
ATLAS RADIO, INC.

RECEIVER INPUT FILTER ADJUSTMENT

Equipment Required

- 1 RF Signal Generator
- 2 Power Supply Extender Cable or 200PS
- 3 Plastic Hex tuning wand

Procedure

- 1 Remove top cover of transceiver.
- 2 Connect power to transceiver using extender cable.
- 3 Connect output of RF Signal Generator to antenna connector.
- 4 Place bandswitch in lowest band.
- 5 Tune transceiver to center of band.
- 6 Place function switch in Rec.
- 7 Advance RF gain control fully clockwise.
- 8 Set output of RF Signal Generator to 10 uv and tune for greatest indication on S-meter.
- 9 Adjust top, then bottom slug of appropriate receiver input coil for greatest S-meter indication.

NOTE:

Receiver input coils are located behind and under the dial drum. The lowest band is farthest to the left and the highest band is furthest to the right. Later sets use fixed tuning for 40 meters and below requiring tuning on 20 meters and above only.

73,

Clint Call W6OFT
Customer Service Mgr.
ATLAS RADIO, INC.

CARRIER NULL (SUPPRESSION) ADJUSTMENT

EQUIPMENT NEEDED

- 1 Dummy Load
- 2 VTVM
- 3 Power Supply Extender Cable or 200PS

PROCEDURE

- 1 Remove top cover of transceiver.
- 2 Connect dummy load to antenna connector.
- 3 Connect power to transceiver using extender cable.
- 4 Place bandswitch in lowest band.
- 5 Place function switch in TRANS. (do not connect mike to input.)
- 6 Measure RF output at center lead of antenna connector; if output is greater than .1VAC proceed with step #7.
- 7 Carefully adjust C103 and R101 alternately for lowest reading on VTVM. C103 is located at the upper rear of the PC-100 board and R101 is just forward of C103 and L102 (toroid). (On the PC-120 board R101 is forward and above C103).

NOTE:

IF the lowest reading obtainable is greater than .2 VAC mixer diodes D101 through D104 should be replaced.

73,

Clint Call W6OFT
Customer Service Mgr.

POWER AMPLIFIER BIAS ADJUSTMENT

Equipment Required

- 1 Dummy Load
- 2 Power Supply Extender Cable or 200PS.

Procedure

- 1 Connect dummy load to antenna connector.
- 2 Connect power to transceiver using extender cable.
- 3 Place bandswitch in lowest band.
- 4 Place function switch in CW.
- 5 Advance Mike Gain Control fully clockwise for about 10 seconds to allow finals to reach normal operating temperature.
- 6 Turn Mike Gain Control full CCW. Place function switch in Transmit.
- 7 Adjust Bias adjust R515 for a reading of 1/4 to 1/2 amp on ampmeter.

Note 1:

Bias adjust R515 is a screwdriver adjustment which can be reached through the small hole in the center, left of the heat sink.

CAUTION: Bias settings in excess of 1/2 amp will cause distortion and may result in damage to the final PA transistors

Note 2:

Carrier null adjustment should be performed before attempting to adjust PA bias.

73,

Clint Call W6OFT
Customer Service Mgr.
ATLAS RADIO, INC.

S-METER ADJUSTMENT PROCEDURE

Equipment Needed

- 1 RF Signal Generator
- 2 Power Supply Extender Cable or 200PS

Procedure

- 1 Remove top cover of transceiver to permit access to S-meter adjust R220.
- 2 Connect power using extender cable.
- 3 Place function switch in REC and band switch in 3.5 MHZ (80 meter) position.
- 4 Connect output of RF signal generator to antenna connector of transceiver and adjust sig. generator to 3.7 MHZ at 30 uv output.
- 5 Advance RF gain control fully clockwise.
- 6 Tune transceiver for greatest deflection of S-meter.
- 7 Adjust R220 for a reading of S9. S-meter will now indicate correctly.

NOTE:

S-meter adjust R220 is located just behind the front panel dimmer switch, under and just to the left of the dial drum, on the PC-200 board.

73,

Clint Call W6OFT
Customer Service Manager
ATLAS RADIO, INC.

HIGH-SWR PROTECT CIRCUIT ADJUSTMENT
FOR 210X

Equipment Required

- 1 Audio Signal Generator
- 2 Power Supply Extender Cable or 200PS

Procedure

- 1 Perform ALC adjustment procedure and bias adjustment.
- 2 remove the two bolts from the top sides of the PA heat sink and open the heat sink case to permit access to the power amplifier circuitry.
- 3 Connect power to transceiver using power supply extender cable.
- 4 Connect audio signal generator to mike input receptacle and adjust for 1500 cycles at .03 VAC.
- 5 Place bandswitch in 20 meter band (14 MHZ).
- 6 Place function switch in Trans.
NOTE: Leave antenna open circuited.
- 7 Advance mike gain control fully clockwise.
- 8 Advance SWR adjust* until ammeter on front panel indicates 6 amps. The SWR Protect Circuit is now correctly adjusted.

73,

Clint Call W6OFT
Customer Service Mgr.
ATLAS RADIO, INC.

* The SWR adjust is a subminiature potentiometer located on the far left side of the PA circuitry.

MODIFYING THE ATLAS 210X FOR AMPLITUDE MODULATION (AM) TRANSMISSION

This fairly simple operation will provide for carrier insertion in transmit mode with the Atlas transceiver, and permits AM transceivers to copy voice transmissions from the Atlas. Carrier output will be 10 to 15 watts, and will be very clear provided the Mic. Gain is not turned up to the point of overmodulation. Reception of an AM signal with the Atlas will still require tuning his carrier for zero beat, but this is a relatively small inconvenience, and the modification described here does make it possible for an AM station to work the Atlas.

The original Atlas circuit has an ALC (Automatic Level Control) concentric with the Mic. Gain control. The ALC control has a knurled aluminum knob. ALC is a convenience which helps prevent overmodulation, but is not really a necessity, and may be dispensed with if AM transmission is desired.

First remove the cabinet and locate the dual potentiometers that are the Mic. Gain and ALC controls. The rear section is the Mic. Gain, and front section is ALC control.

Step 1 - Locate the blue and white/green wires that go to the center and upper lugs, respectively, of the front control. Unsolder these wires and tape the ends individually so they will not short circuit with anything. They will no longer be used, and can be tucked away into the chassis corner.

Step 2 - Connect a 10K 1/4 watt resistor from the center lug down to terminal #7 of the PC-100 edge connector. This will require splicing an extension wire to the resistor. Solder the splice and then cover the entire wire and resistor with a plastic sleeving, as illustrated, to prevent short circuiting.

Step 3 - Connect a second 10K 1/4 watt resistor from the upper lug down to terminal #22 of the PC-100 edge connector. This will also require splicing and soldering an extension wire to the resistor. Put plastic sleeving over the entire resistor and wire leads, as illustrated, to prevent shorts.

Use caution when soldering to all terminals. Do a neat and careful job, and inspect for shorts or solder bridges to other terminals or to the chassis.

Step 4 - A 10K or 15K resistor will be found going from the Function switch to the upper lug on the rear section of the dual pot. (Mic. Gain). Unsolder or cut the resistor loose at the potentiometer lug. Shorten the resistor lead by 3/8 to 1/2 inch, and solice a 1N4148 or 1N914 silicon diode to the resistor. Observe polarity as illustrated, with the cathode end, black band pointing upward. Solder the splice carefully with a small iron, using just enough heat to make a good solder job. Place a piece of plastic sleeving over both the diode and resistor to prevent shorts. Then solder the top end of the diode to the upper lug, where the resistor formerly went. Be sure the cathode end, black band, is connected to the potentiometer lug, as illustrated.

Step 5 - Adjustment Procedure. It will be necessary to make a minor adjustment of the carrier frequency on both "NORM" and "OPP" sidebands. "NORM" on the sideband selector switch is the one normally used in the amateur bands, being Lower Sideband (LSB) on 160, 75, and 40 meters, and Upper Sideband (USB) on 20, 15, and 10 meters.

The trimmers that adjust carrier frequency are located on PC-600 alongside the speaker, and are accessible from the bottom side of the transceiver, as illustrated.

(a) Connect the transceiver to a dummy load, or if none is available connect to a properly matched antenna for the band to be used. Before turning the set on, move the bandswitch to the desired band, set Sideband selector to "NORM" position, and turn both Mic. Gain and Carrier Insertion (formerly ALC) to full counterclockwise position, (CCW).

(b) Switch to "TRANS" mode with the Function switch. Do not go to the "CW" position, just to "TRANS". Note that the ammeter reading is very small, about 1/4 amp. If it reads more than 1/2 amp. (half of the first increment), the P.A. Bias needs adjustment. This is done with a small screwdriver through the adjusting hole on back of the heat sink below the driver transistor. Set it for about 1/4 amp. resting current. Carrier insertion must be at minimum, CCW.

(c) Now advance the Carrier Insertion control until the ammeter reads 3 amps. If you cannot reach 3 amps. with the control, adjust the NORM carrier freq. trimmer until you can. Move the trimmer slowly, and in the direction that increases the ammeter reading.

If you can reach 3 amps before the control is fully clockwise, adjust the carrier freq. trimmer for a lower ammeter reading until you can just make 3 amps. at full clockwise setting of the carrier insertion control.

(d) Repeat step (c) on the "OPP" sideband.

Step 6 - Modulation Control. Advance the Mic. Gain until the ammeter kicks upward slightly when speaking, to 4 amps., or so. Modulating heavier than this will produce reports of distortion on the signal.

CAUTION: Do not insert more than 3 amps of carrier, as indicated on the ammeter. More than this will cause excessive heating of the P.A. output transistors, and can lead to their failure. Watch the heat sink temperature, and be sure it does not get so hot that you can't hold your hand on it.

210X
FRONT PANEL

FORMER ALC CONTROL
BECOMES CARRIER
INSERTION CONTROL.

MIC.
GAIN

ADD DIODE IN SERIES
WITH ORIGINAL 10K OR
15K RESISTOR

FUNCTION
SWITCH

#10
SLEEVING PLACED
OVER COMPONENTS
AND LEADS TO
PREVENT SHORTING,

ORIGINAL
ALC LEADS
CUT FROM
POTENTIOMETER
LUGS
ENDS TAPED
TO PREVENT
SHORTING.

#22

7

4

1

R.F.
GAIN

A.F.
GAIN

BOTTOM VIEW

Sideband Selector "OPP" Sideband Trimmer "NORM" Sideband Trimmer

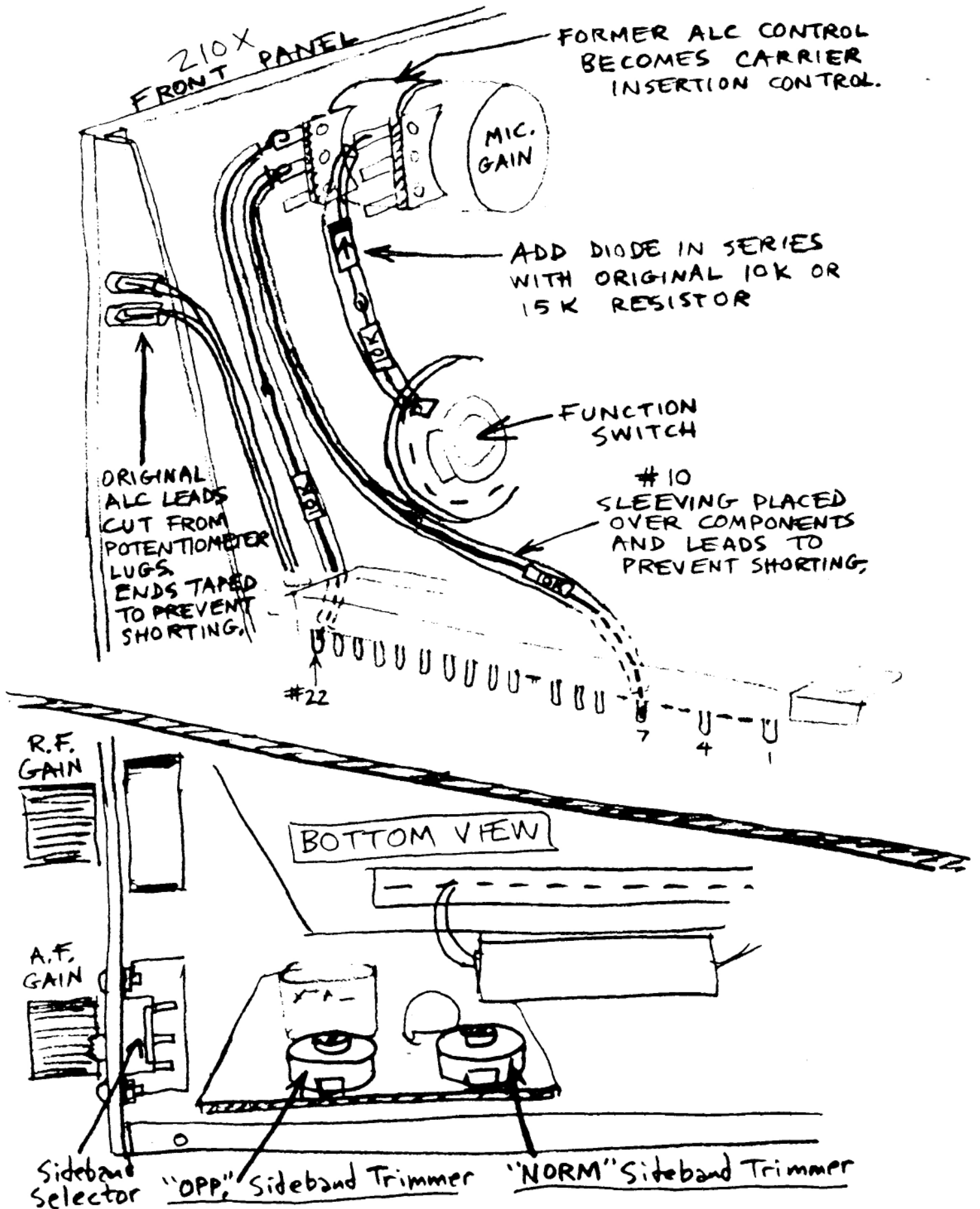

HOW TO CONVERT THE ATLAS 210X FOR CITIZEN'S BAND RECEPTION

Step 1 - Remove the transceiver's upper cabinet. Turn the tuning knob counter-clockwise until the dial drum will not turn any further. Note that it stops right at the low frequency end of the dial scale. Remember that the new dial scale should be adjusted to this same position.

Step 2 - Now, using a 5/64 in. Allen wrench, loosen the dial drum set screw, and remove the dial drum. Remove the tape from the ends of the original dial scale, and peel the scale from the drum. Take the new dial scale and practice applying it to the dial drum. Hold the drum down on a flat surface, and begin by holding one end of the new scale on one end of the drum, and smoothly rotating the rest of the scale against the drum until it is all on. After you get the idea, then peel off the backing paper on the new dial scale, and apply it to the drum. Finally, apply short pieces of masking tape, or scotch tape to the ends, similar to what the original dial had. This is to keep the ends from coming loose.

Step 3 - Replace the dial drum in the set. Position it as before, so that in the full low frequency position the low end of the scale lines up with the index line on the dial window. Then tighten the set screw carefully, just tight enough to hold the drum securely. Caution: Over tightening can crack the plastic hub.

Step 4 - Frequency Calibration: A signal of known frequency will be convenient. For example, an AM signal on channel 23 may be used. Set the dial to channel 23, which is at 27.255 MHz, and adjust the 28.5 trimmer on top of the VFO for zero beat. If the Atlas Digital Dial is used, simply adjust the 28.5 trimmer for correct dial calibration.

Step 5 - Receiver input tuning: A plastic hexagon alignment tool, (1/10 in. across flats) is required. GC #8606, or equivalent. Locate the 10 meter input transformer, (see Fig. 1) This transformer has an upper and a lower core. Screw the upper core 1 turn clockwise, and the lower core 1 turn counterclockwise. Then, using either a signal generator connected to the Ant. jack, or a signal being received by an antenna, adjust the two cores for maximum S-meter reading. An AM signal with a steady carrier is best. If no signal is present, the antenna noise level is often high enough for tuning purposes. Adjust the cores for maximum noise. This is satisfactory even if there is no S-meter movement.

Step 6 - Transmitter Input Tuning:

(A) Early 210X: The 10 meter trimmers are located at the bottom of the tuning board. (See Fig. 2) A right angle adaptor for the PC-100 (or PC-120 noise blanker model) plug in card will be required in order to reach these trimmers. Remove the card, and plug it back in using the adaptor, as illustrated. Be sure the relay is facing up.

(B) Later 210X: The 10 meter trimmers are located at the top of the tuning board, (See Fig. 3), and can be reached without removing the plug in card, and without the need for a right angle adaptor.

(C) A Dummy Load is recommended for tuning. If one is not available, use an antenna with 50 ohm coaxial feedline. It must be closely matched to 50 ohms, with low SWR, or it will not work well with the Atlas transceiver.

(D) Tuning Procedure: Set the tuning dial to approx. band center. Be sure that the sideband selector switch, located under the A.F. Gain control is in the NORM position. (Note that NORM position is Upper Sideband, and OPP is Lower Sideband). The CW mode does not function in OPP position, so for tuning the sideband switch must be in the NORM position.

Move the function switch to "CW" mode, and advance the Mic. Gain control to about 12 o'clock. Then screw the 10 meter trimmers (Fig. 2 or 3), clockwise until the ammeter on the transceiver panel moves upward. It will normally be idling at about 1/4 amp. until there is transmit power. If turning the trimmers has produced a reading of more than 6 or 7 amps., quickly turn the Mic. Gain control down for a reading of about 3 amps. Then, adjust both trimmers again for maximum reading. If it goes over 6 or 7 amps. again, quickly turn down the Mic. Gain for a reading of about 3 amps.

Continue this procedure until you have found the peak position on both trimmers. The reason for holding the ammeter reading down below 6 or 7 amps. is to avoid excessive heat dissipation in the power transistors. They can draw 3 amps collector current for lengthy periods with no harm, but if the current is allowed to run up over 7 or 8 amps. they will heat up rapidly.

In any case, limit tuning time in CW mode to a 2 or 3 minute maximum. Never turn the Mic. Gain control up to full power for more than 5 or 6 seconds at a time, just long enough to see what the maximum collector current (power input) will be. CAUTION: Observe the notes on Modulation Level and Heat Sink Temperature which are in the Atlas manual.

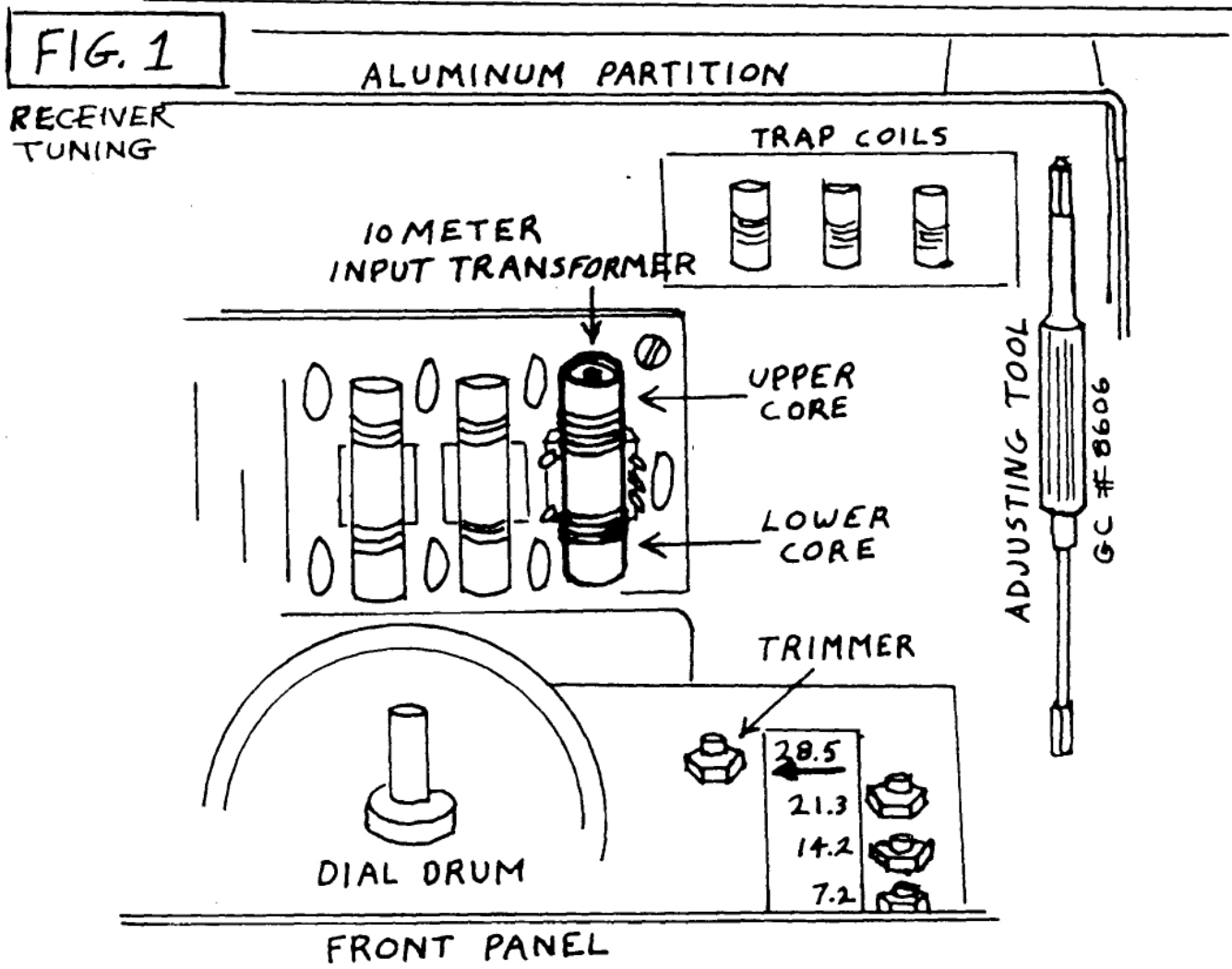

FIG. 2
EARLY 210X

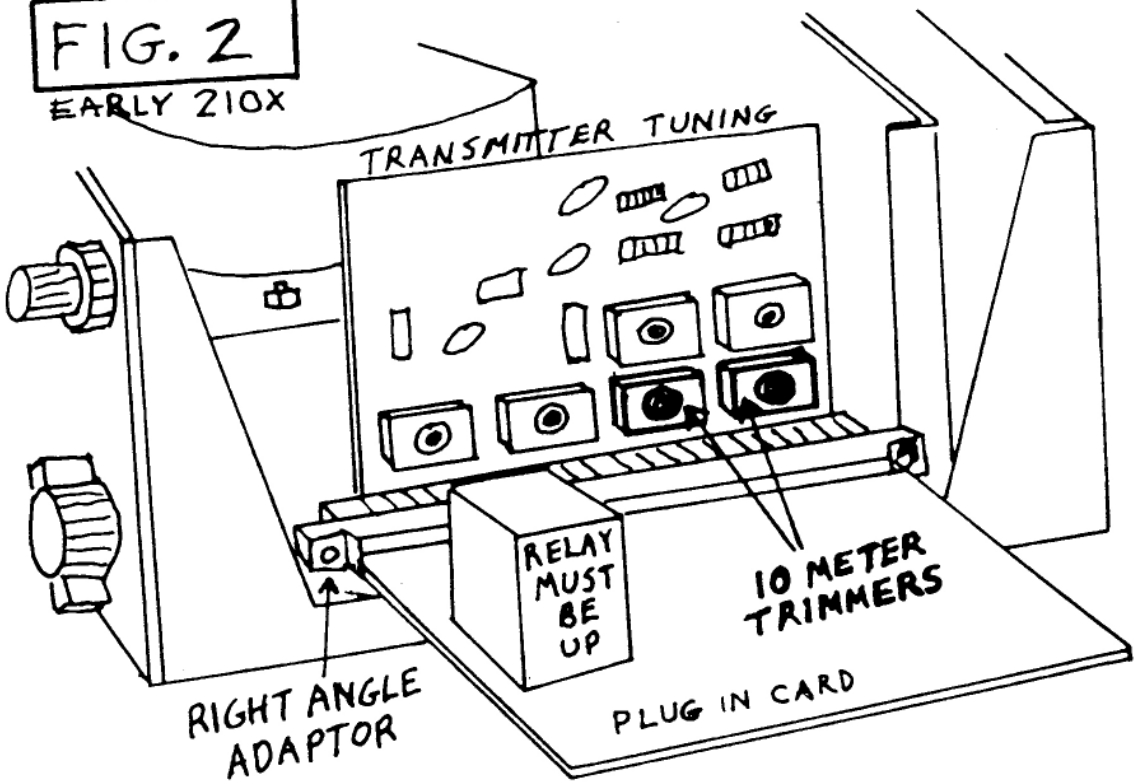
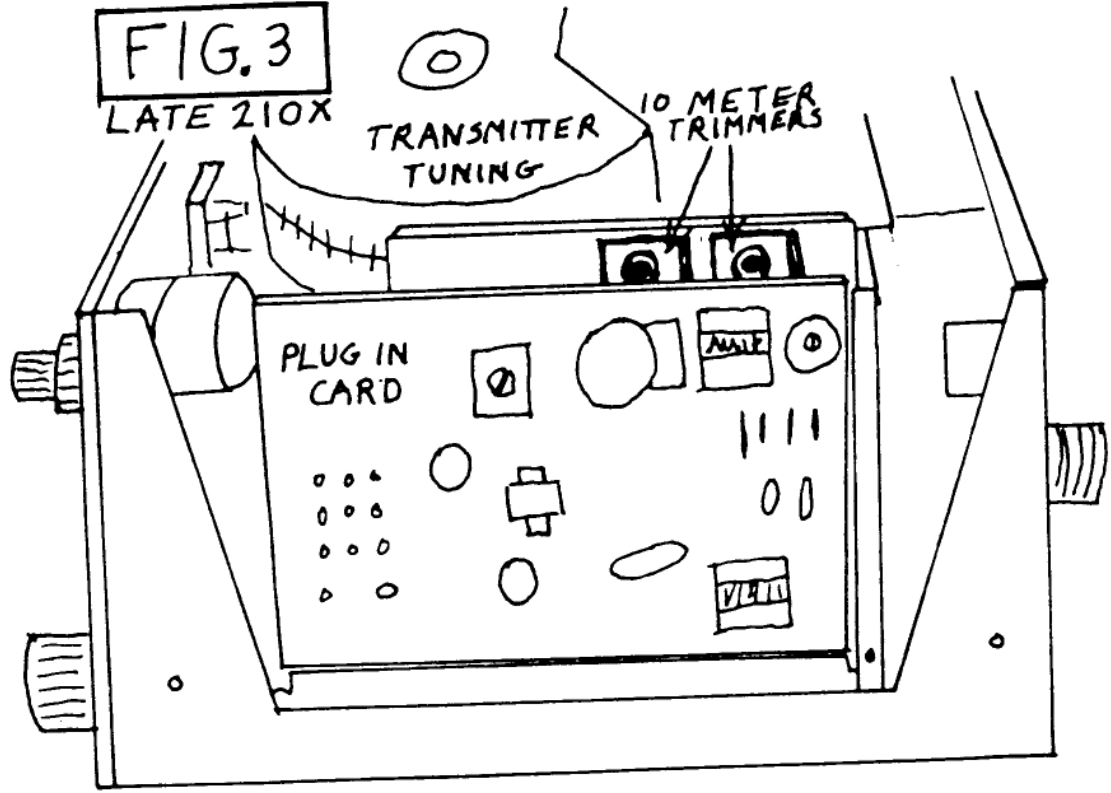

FIG. 3
LATE 210X



ATLAS TRANSCEIVERS, MOBILE INSTALLATION NOTES:

There are a number of important details to observe when making your mobile installation.

(1) The transceiver must have a direct ground connection to the car body. This must be done through the mounting brackets. Do not rely on the DC cable running to the battery, or on the coaxial cable going to the antenna.

If you are installing the Atlas plug-in mobile mount, the mounting brackets will provide a good ground through the screws that secure the brackets to the transmission hump or firewall. Use the large 1/4 inch screws, and make certain that they are tight. Also, make certain that all the screws in the plug-in mounting assembly are tight, and that internal tooth shakeproof washers are in place under the screw heads and nuts. The black anodized finish is actually a very good insulation, and it is important that the shakeproof washers cut through the anodizing to make electrical contact. If there is any doubt, connect a piece of copper braid from the antenna bracket to the mounting bracket.

If you are installing the transceiver using the Atlas bracket kit, (not the plug-in model), it will be best to use a piece of copper braid from a mounting screw on the transceiver to one of the mounting brackets. This will serve as a backup ground connection in the event a good ground is not being secured between the brackets and the transceiver.

(2) At the antenna mount it is very important that the coaxial cable be grounded securely to the auto body or frame. If you are cowl mounting the antenna, one of the mounting screws for the ball mount will normally give a good ground connection to the body.

If you are using a rear bumper mount, make certain that the bumper is electrically connected to the frame of the car. Some of the late model cars have rubber mounting parts, and the bumper may not be connected electrically. If this is the case, run the coax shield braid back to the body, and ground it with a good sized sheet metal screw, or nut and bolt.

(3) Impedance matching to the antenna. Practically all the common mobile antennas on the market have a base impedance in the 15 to 25 ohm range when installed on an automobile. For this reason, we recommend the Atlas model MT-1 matching transformer, in order to run full power. Large motor homes are generally an exception, and do not require the transformer. Their larger ground area increases the base impedance to nearly 50 ohms. The same is true on marine installations.

(4) Information on mobile noise suppression is available from the factory, if required.

If you have any problems or questions about your mobile installation, please contact us.

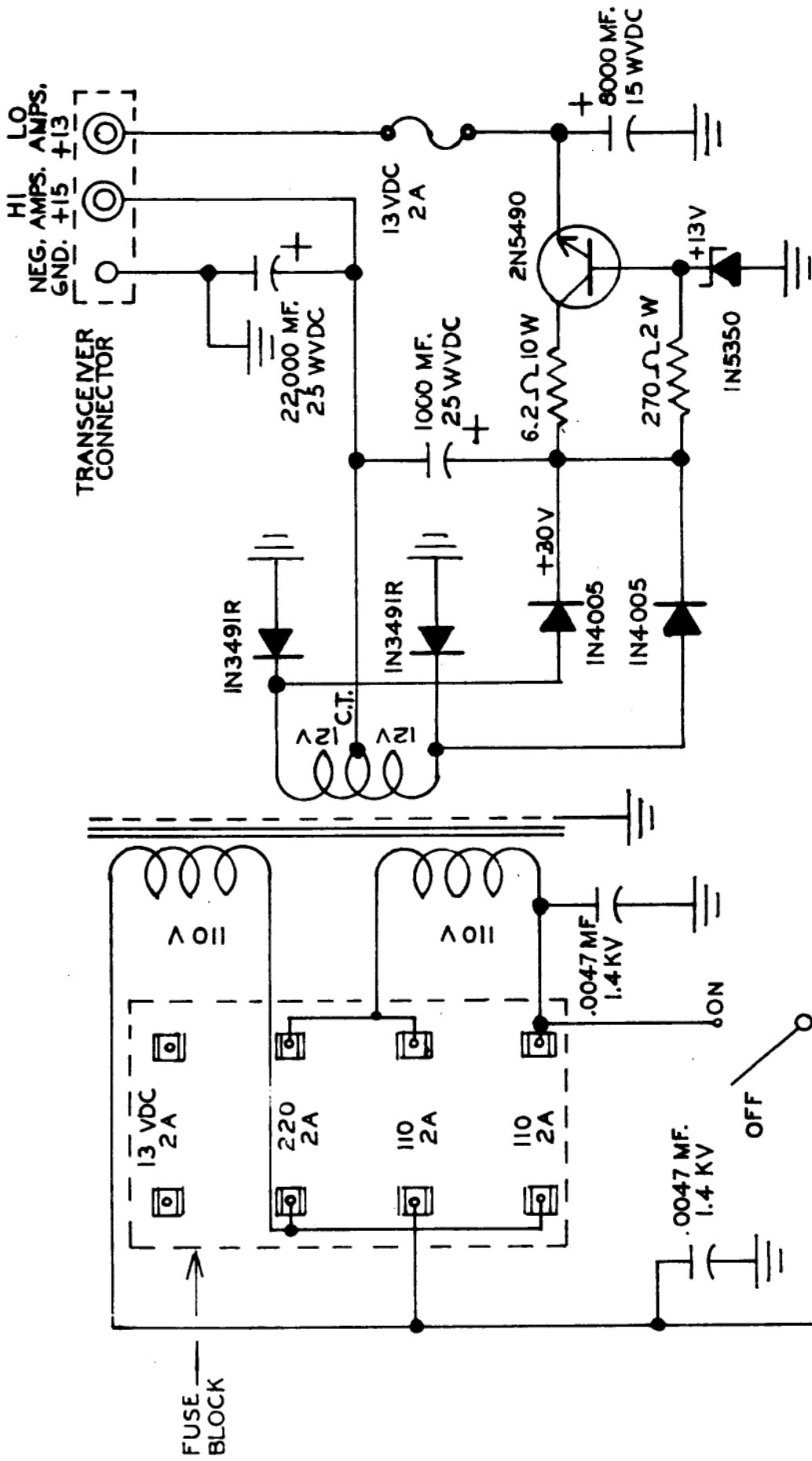

Model 200-PS Portable Supply
 10/6/75 Atlas Radio, Inc.