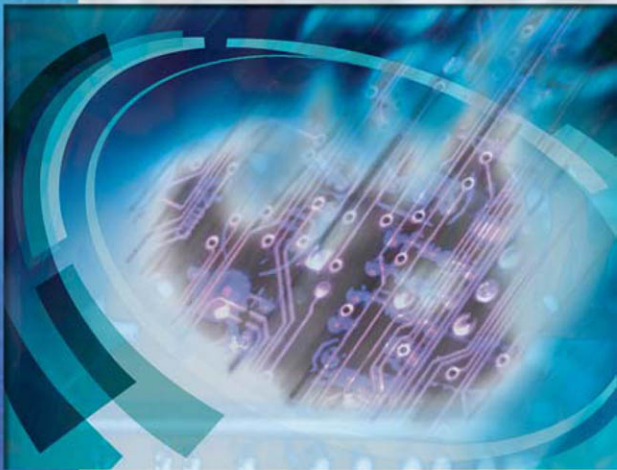


Introduction to Electronics



5th Edition

Gates



INTRODUCTION TO ELECTRONICS

FIFTH EDITION

Earl D. Gates



Australia • Brazil • Japan • Korea • Mexico • Singapore • Spain • United Kingdom • United States

**Introduction to Electronics,
Fifth Edition****Earl D. Gates**Vice President, Technology
and Trades ABU: David Garza

Editorial Director: Sandy Clark

Executive Editor: Stephen Helba

Senior Development Editor:
Michelle Ruelos CannistraciMarketing Director: Deborah
Yarnell

Channel Manager: Dennis Williams

Marketing Coordinator:
Stacey WiktorekSenior Production Manager:
Larry MainSenior Project Editor: Christopher
ChienTechnology Project Manager:
Kevin SmithTechnology Project Specialist:
Linda VerdeSenior Editorial Assistant:
Dawn Daugherty

© 2007, 2004, 2001, 1998, 1995 Delmar, Cengage Learning

ALL RIGHTS RESERVED. No part of this work covered by the copyright herein may be reproduced, transmitted, stored or used in any form or by any means graphic, electronic, or mechanical, including but not limited to photocopying, recording, scanning, digitizing, taping, Web distribution, information networks, or information storage and retrieval systems, except as permitted under Section 107 or 108 of the 1976 United States Copyright Act, without the prior written permission of the publisher.

For product information and technology assistance, contact us at
Cengage Learning Customer & Sales Support, 1-800-354-9706

For permission to use material from this text or product,
submit all requests online at www.cengage.com/permissions

Further permissions questions can be emailed to
permissionrequest@cengage.com

Library of Congress Control Number: 2005037442

ISBN-13: 978-1-4018-8900-5

ISBN-10: 1-4018-8900-X

DelmarExecutive Woods
5 Maxwell Drive
Clifton Park, NY 12065
USA

Cengage Learning is a leading provider of customized learning solutions with office locations around the globe, including Singapore, the United Kingdom, Australia, Mexico, Brazil, and Japan. Locate your local office at www.cengage.com/global

Cengage Learning products are represented in Canada by Nelson Education, Ltd.

To learn more about Delmar, visit www.cengage.com/delmar

Purchase any of our products at your local bookstore or at our preferred online store www.ichapters.com

Notice to the Reader

Publisher does not warrant or guarantee any of the products described herein or perform any independent analysis in connection with any of the product information contained herein. Publisher does not assume, and expressly disclaims, any obligation to obtain and include information other than that provided to it by the manufacturer. The reader is expressly warned to consider and adopt all safety precautions that might be indicated by the activities described herein and to avoid all potential hazards. By following the instructions contained herein, the reader willingly assumes all risks in connection with such instructions. The publisher makes no representations or warranties of any kind, including but not limited to, the warranties of fitness for particular purpose or merchantability, nor are any such representations implied with respect to the material set forth herein, and the publisher takes no responsibility with respect to such material. The publisher shall not be liable for any special, consequential, or exemplary damages resulting, in whole or part, from the readers' use of, or reliance upon, this material.

CONTENTS

Preface / vii
Careers in Electronics / xii
Using a Calculator / xvi
Safety Precautions / xix

SECTION 1 DC CIRCUITS 1

Chapter 1 Fundamentals of Electricity 3

- 1-1 Matter, Elements, and Compounds / 4
- 1-2 A Closer Look at Atoms / 5
- 1-3 Current / 7
- 1-4 Voltage / 7
- 1-5 Resistance / 8

Chapter 2 Current 10

- 2-1 Electrical Charge / 10
- 2-2 Current Flow / 11
- 2-3 Scientific Notation / 13

Chapter 3 Voltage 17

- 3-1 Voltage Sources / 17
- 3-2 Cells and Batteries / 21
- 3-3 Connecting Cells and Batteries / 24
- 3-4 Voltage Rises and Voltage Drops / 27
- 3-5 Ground as a Voltage Reference Level / 28

Chapter 4 Resistance 31

- 4-1 Resistance / 31
- 4-2 Conductance / 32
- 4-3 Resistors / 32
- 4-4 Resistor Identification / 37
- 4-5 Connecting Resistors / 40
- 4-6 Connecting Resistors in Series / 40

- 4-7 Connecting Resistors in Parallel / 41
- 4-8 Connecting Resistors in Series and Parallel / 43

Chapter 5 Ohm's Law 49

- 5-1 Electric Circuits / 49
- 5-2 Ohm's Law / 51
- 5-3 Application of Ohm's Law / 53
- 5-4 Kirchhoff's Current Law / 57
- 5-5 Kirchhoff's Voltage Law / 58

Chapter 6 Electrical Measurements— Meters 61

- 6-1 Introduction to Meters / 62
- 6-2 Types of Meters / 63
- 6-3 Multimeters / 64
- 6-4 Measuring Current / 65
- 6-5 Measuring Voltage / 67
- 6-6 Measuring Resistance / 68
- 6-7 Reading Meter Scales / 70

Chapter 7 Power 75

- 7-1 Power / 75
- 7-2 Power Application (Circuit Analysis) / 76

Chapter 8 DC Circuits 80

- 8-1 Series Circuits / 80
- 8-2 Parallel Circuits / 82
- 8-3 Series-Parallel Circuits / 84
- 8-4 Voltage Dividers / 88
- 8-5 Wheatstone Bridge / 93

Chapter 9 Magnetism 96

- 9-1 Magnetic Fields / 97
- 9-2 Electricity and Magnetism / 99

- 9-3 Magnetic Induction / 101
- 9-4 Magnetic and Electromagnetic Applications / 104

Chapter 10 Inductance **110**

- 10-1 Inductance / 110
- 10-2 Inductors / 111
- 10-3 L/R Time Constants / 113

Chapter 11 Capacitance **116**

- 11-1 Capacitance / 116
- 11-2 Capacitors / 117
- 11-3 RC Time Constants / 120

SECTION 2 AC CIRCUITS **123**

Chapter 12 Alternating Current **125**

- 12-1 Generating Alternating Current / 126
- 12-2 AC Values / 128
- 12-3 Nonsinusoidal Waveforms / 130

Chapter 13 AC Measurements **133**

- 13-1 AC Meters / 133
- 13-2 Oscilloscopes / 136
- 13-3 Frequency Counters / 139
- 13-4 Bode Plotters / 140

Chapter 14 Resistive AC Circuits **142**

- 14-1 Basic AC Resistive Circuits / 142
- 14-2 Series AC Circuits / 143
- 14-3 Parallel AC Circuits / 145
- 14-4 Power in AC Circuits / 146

Chapter 15 Capacitive AC Circuits **148**

- 15-1 Capacitors in AC Circuits / 148
- 15-2 Applications of Capacitive Circuits / 151

Chapter 16 Inductive AC Circuits **155**

- 16-1 Inductance in AC Circuits / 155
- 16-2 Applications of Inductive Circuits / 158

Chapter 17 Resonance Circuits **161**

- 17-1 Reactance in Series Circuits / 161
- 17-2 Reactance in Parallel Circuits / 165
- 17-3 Power / 167
- 17-4 Introduction to Resonance / 168

Chapter 18 Transformers **171**

- 18-1 Electromagnetic Induction / 171
- 18-2 Mutual Inductance / 172
- 18-3 Turns Ratio / 173
- 18-4 Applications / 175

SECTION 3 SEMICONDUCTOR DEVICES **181**

Chapter 19 Semiconductor Fundamentals **183**

- 19-1 Semiconduction in Germanium and Silicon / 184
- 19-2 Conduction in Pure Germanium and Silicon / 186
- 19-3 Conduction in Doped Germanium and Silicon / 187

Chapter 20 PN Junction Diodes **191**

- 20-1 PN Junctions / 191
- 20-2 Diode Biasing / 193
- 20-3 Diode Characteristics / 194
- 20-4 Diode Construction Techniques / 195
- 20-5 Testing PN Junction Diodes / 197

Chapter 21 Zener Diodes **199**

- 21-1 Zener Diode Characteristics / 199
- 21-2 Zener Diode Ratings / 200
- 21-3 Voltage Regulation with Zener Diodes / 201
- 21-4 Testing Zener Diodes / 202

Chapter 22 Bipolar Transistors **204**

- 22-1 Transistor Construction / 204
- 22-2 Transistor Types and Packaging / 206

- 22-3 Basic Transistor Operation / 206
- 22-4 Transistor Testing / 208
- 22-5 Transistor Substitution / 209

Chapter 23 Field Effect

Transistors (FETs) 213

- 23-1 Junction FETs / 213
- 23-2 Depletion Insulated Gate FETs
(MOSFETs) / 216
- 23-3 Enhancement Insulated Gate FETs
(MOSFETs) / 218
- 23-4 MOSFET Safety Precautions / 220
- 23-5 Testing FETs / 220

Chapter 24 Thyristors 223

- 24-1 Silicon-Controlled Rectifiers / 223
- 24-2 TRIACs / 226
- 24-3 Bidirectional Trigger Diodes / 228
- 24-4 Testing Thyristors / 229

Chapter 25 Integrated Circuits 232

- 25-1 Introduction to Integrated Circuits / 233
- 25-2 Integrated Circuit Construction
Techniques / 234
- 25-3 Integrated Circuit Packaging / 236

Chapter 26 Optoelectric Devices 239

- 26-1 Basic Principles of Light / 240
- 26-2 Light-Sensitive Devices / 240
- 26-3 Light-Emitting Devices / 244

SECTION 4 LINEAR ELECTRONIC CIRCUITS 247

Chapter 27 Power Supplies 249

- 27-1 Transformers / 250
- 27-2 Rectifier Circuits / 250
- 27-3 Filter Circuits / 253
- 27-4 Voltage Regulators / 256
- 27-5 Voltage Multipliers / 261
- 27-6 Circuit-Protection Devices / 263

Chapter 28 Amplifier Basics 267

- 28-1 Amplifier Configurations / 267
- 28-2 Amplifier Biasing / 269
- 28-3 Amplifier Coupling / 273

Chapter 29 Amplifier Applications 277

- 29-1 Direct-Coupled Amplifiers / 277
- 29-2 Audio Amplifiers / 280
- 29-3 Video Amplifiers / 282
- 29-4 RF and IF Amplifiers / 285
- 29-5 Operational Amplifiers / 287

Chapter 30 Oscillators 293

- 30-1 Fundamentals of Oscillators / 293
- 30-2 Sinusoidal Oscillators / 294
- 30-3 Nonsinusoidal Oscillators / 298

Chapter 31 Waveshaping Circuits 302

- 31-1 Nonsinusoidal Waveforms / 302
- 31-2 Waveshaping Circuits / 305
- 31-3 Special-Purpose Circuits / 309

SECTION 5 DIGITAL ELECTRONIC CIRCUITS 313

Chapter 32 Binary Number System 315

- 32-1 Binary Numbers / 315
- 32-2 Binary and Decimal Conversion / 317
- 32-3 BCD Code / 319

Chapter 33 Basic Logic Gates 321

- 33-1 AND Gate / 321
- 33-2 OR Gate / 322
- 33-3 NOT Gate / 323
- 33-4 NAND Gate / 323
- 33-5 NOR Gate / 324
- 33-6 Exclusive OR and NOR Gates / 325
- 33-7 Buffer / 327

Chapter 34 Simplifying Logic Circuits 330

- 34-1 Veitch Diagrams / 330
- 34-2 Karnaugh Maps / 333

Chapter 35 Sequential Logic Circuits 338

- 35-1 Flip-Flops / 339
- 35-2 Counters / 342
- 35-3 Shift Registers / 345
- 35-4 Memory / 351

Chapter 36 Combinational Logic Circuits 356

- 36-1 Encoders / 356
- 36-2 Decoders / 358
- 36-3 Multiplexers / 360
- 36-4 Arithmetic Circuits / 363
- 36-5 Programmable Logic Devices (PLDs) / 368

Chapter 37 Microcomputer Basics 371

- 37-1 Computer Basics / 372
- 37-2 Microprocessor Architecture / 375
- 37-3 Microcontrollers / 378

SECTION 6 PRACTICAL APPLICATIONS 383**Chapter 38 Printed Circuit Board Fabrication 385**

- 38-1 Fundamentals / 385
- 38-2 Schematic Diagram / 389
- 38-3 Breadboarding / 395
- 38-4 Laying Out Printed Circuit Boards / 396
- 38-5 Transferring Designs / 402
- 38-6 Etching Printed Circuit Boards / 403
- 38-7 Preparing the Etched Printed Circuit Board / 405
- 38-8 Material Safety Data Sheet (MSDS) / 406

Chapter 39 Printed Circuit Board Assembly and Repair 415

- 39-1 Electronics Technician Toolbox / 416
- 39-2 Electronic Test Equipment / 421

- 39-3 Solder and Soldering Irons / 424
- 39-4 Soldering a Printed Circuit Board / 427
- 39-5 Analyzing Soldered Connections / 433
- 39-6 Protective Coatings / 434
- 39-7 Safety Precautions / 435
- 39-8 Electrostatic Discharge / 438

Chapter 40 Basic Troubleshooting 444

- 40-1 Tools for Troubleshooting / 444
- 40-2 Isolation Techniques for Effective Troubleshooting / 448
- 40-3 Common Types of Defects / 449
- 40-4 Troubleshooting Tips / 452
- 40-5 Documentation / 452

Glossary 455**Self-Test Answers 467****Appendices 503**

- Appendix 1—Electronics Abbreviations / 503
- Appendix 2—Periodic Table of Elements / 504
- Appendix 3—The Greek Alphabet / 505
- Appendix 4—Metric Prefixes Used in Electronics 506
- Appendix 5—Resistor Color Codes / 507
- Appendix 6—Capacitor Color Code / 508
- Appendix 7—Electronics Symbols / 511
- Appendix 8—Semiconductor Schematic Symbols / 512
- Appendix 9—Digital Logic Symbols / 513
- Appendix 10—DC and AC Circuit Formulas / 514

Index 515

PREFACE

INTENDED AUDIENCE

Introduction to Electronics is intended to meet the needs of a one-year program in electronics for high schools, vocational schools, career colleges, and community colleges. The book may also be used in a survey course in electronics for electronics technology, computer technology, and telecommunications. The fifth edition continues to give students the basic background that more closely relates to the needs of industry. It provides the hands-on instruction required by industry along with the required theory.

BACKGROUND OF THIS BOOK

This fifth edition has the same objectives as the four previous editions, namely, to provide a text and reference book that summarizes in understandable terms those principles and techniques that are the basic tools of electronics. In keeping with current trends, increased emphasis is placed on the general techniques of electronics. During my teaching in public school I completed a study on what industry wanted from students graduating with a background in electronics. I found that industry valued students' ability to *do* more than their ability to *know*. I found that industry wanted less time spent on teaching theory and more time spent on instructing hands-on applications.

After I had rewritten my curriculum, I found I had to use several textbooks to teach it. I originally wrote the first edition of *Introduction to Electronics* to provide the students with all the information required by the curriculum in one easy-to-use textbook. The fifth edition continues to refine the

needs of the students through input from teachers and changes from the electronics field.

TEXTBOOK ORGANIZATION

Due to the rapid growth of electronics, it becomes impossible to cover all of the important topics in a one-year course. *Introduction to Electronics* provides the instructor with an opportunity to select those topics that he/she wishes to emphasize and, at the same time, provides the student with a reference book of basic electronics coverage and continuing value.

Teachers can guide students to concentrate on the material related to a particular course syllabus, leaving the remaining subject matter as enrichment should students wish to extend their knowledge at a future date. Alternatively, instructors can choose to cover a series of selected topics, such as DC and AC circuits. Another possibility is to concentrate on the material related primarily to linear electronics circuits or another topic of choice. Many other combinations are possible.

The emphasis still continues to be coverage of electronics combined with a presentation that allows the student to study a particular topic without having to read the entire text. The level of the presentation remains unchanged.

The textbook is divided into six separate sections.

Section 1—DC Circuits discusses fundamentals of electricity, current, voltage, resistance, ohm's law, electrical measurements—meters, power, DC circuits, magnetism, inductance, and capacitance.

Section 2—AC Circuits discusses alternating current, AC measurement, resistive AC circuits, capacitive AC circuits, inductive AC circuits, resonance circuits, and transformers.

Section 3—Semiconductor Devices discusses semiconductor fundamentals, PN junction diodes, zener diodes, bipolar transistors, field effect transistors (FET), thyristors, integrated circuits, and optoelectric devices.

Section 4—Linear Electronic Circuits discusses power supplies, amplifier basics, amplifier applications, oscillators, and waveshaping circuits.

Section 5—Digital Electronic Circuits discusses binary number systems, basic logic gates, simplifying logic circuit, sequential logic circuits, combinational logic circuits, and microcomputer basics.

Section 6—Practical Applications discusses fabricating a printed circuit board, printed circuit board assembly and repair, and basic troubleshooting.

A **Glossary** contains key terms and definitions.

Self-Test Answers are included for students.

Appendices include Appendix 1—Electronics Abbreviations, Appendix 2—Periodic Table of Elements, Appendix 3—The Greek Alphabet, Appendix 4—Metric Prefixes Used in Electronics, Appendix 5—Resistor Color Code, Appendix 6—Capacitor Color Code, Appendix 7—Electronics Symbols, Appendix 8—Semiconductor Schematic Symbols, Appendix 9—Digital Logic Symbols, and Appendix 10—DC and AC Circuit Formulas.

FEATURES

The following list provides some of the significant features of the textbook.

- Chapters are brief and focused.
- Objectives are clearly stated with the learning goals at the beginning of each chapter.
- Colorful illustrations are generously used throughout the text to strengthen concepts learned.
- Cautions and notes are color coded for easy identification throughout the text.
- Review questions appear at the end of every chapter subdivision to allow a comprehension check.
- All formulas are written using fundamental formulas only.
- Many examples show math and formulas in use throughout the text.
- Summaries are included at the end of each chapter for reviewing important concepts.
- Self-tests are included at the end of each chapter as a learning tool.
- Four-color photographs are used to show the learner exactly what is addressed in the text.
- Four-color layouts focus attention to important features in the text.
- Numerous examples incorporate the chapters' material with real life applications.
- Section activities provide an opportunity to reinforce concepts with hands-on projects.

NEW FEATURES IN THIS EDITION

- New photographs are used throughout the book and detailed, step-by-step examples are included to show how math and formulas are used.
- Many examples have been developed into MultiSIM® version 9 on a companion disk

for students to learn first hand what is happening in the circuit.

- New career profiles are located at the beginning of each section to stimulate the student's interest in further study and/or potential employment in the electronics fields.
- New chapters and chapter sections include:

33–7 Buffer

Section 6—Practical Applications

Chapter 38 Fabricating a Printed Circuit Board

38–1 Fundamentals

38–2 Schematic Diagram

38–3 Breadboarding

38–4 Laying Out Printed Circuit Boards

38–5 Transferring Designs

38–6 Etching Printed Circuit Boards

38–7 Preparing the Etched Printed Circuit Board

38–8 Material Safety Data Sheets (MSDS)

Chapter 39 Printed Circuit Board Assembly and Repair

39–1 Electronics Technician Toolbox

39–2 Electronic Test Equipment

39–3 Solder and Soldering Irons

38–4 Soldering a Printed Circuit Board

38–5 Analyzing Soldered Connections

38–6 Protective Coatings

38–7 Safety Precautions

39–8 Electrostatic Discharge

Chapter 40 Basic Troubleshooting

40–1 Tools for Troubleshooting

40–2 Isolation Techniques for Effective Troubleshooting

40–3 Common Types of Defects

40–4 Troubleshooting Tips

40–5 Documentation

USING THE CD-ROM

The accompanying CD includes MultiSIM™ circuit files. Students can use these precreated files for troubleshooting and simulation. Textbook figures created as MultiSIM files are identified by a CD icon throughout the text.

In addition, the CD includes *Electronics into the Future*, which offers interactive tutorials and presentations on fundamental electronics concepts, such as Ohm's Law, series circuits, parallel circuits, series-parallel circuits, network theorems and magnetism.

THE LEARNING PACKAGE

The complete ancillary package was developed to achieve two goals:

- 1 To assist students in learning the essential information needed to prepare for the exciting field of electronics.
- 2 To assist instructors in planning and implementing their instructional programs for the most efficient use of time and other resources.

LAB MANUAL. Labs provide students with the opportunity to transfer theory provided in class to hands-on practical applications. Projects serve to reinforce the student's learning, providing them the opportunities to see theory become practice. (ISBN: 1-4018-8901-8)

INSTRUCTOR'S GUIDE. The Instructor's Guide contains solutions to end-of-chapter textbook questions and to the lab manual experiments. To assist the instructor/teacher in preparing the program, a curriculum guide is provided in the Instructor's Guide. It helps instructors to provide a program that will develop a student's interest in the field of electronics. (ISBN: 1-4018-8902-6)

E.RESOURCE. The *e.resource* is an educational resource that creates a truly electronic classroom. It is a CD-ROM containing tools and instructional resources that enrich your classroom and make your preparation time shorter. The elements of *e.resource* link directly to the text and tie together to provide a unified instructional system. With the *e.resource*, you can spend your time teaching, not preparing to teach. (ISBN: 1-4018-8903-4)

Features contained in the *e.resource* include:

POWERPOINT PRESENTATION. These slides provide the basis for a lecture outline that helps you to present concepts and material. Key points and concepts can be graphically highlighted for student retention. There are 480 slides, covering every chapter in the text.

COMPUTERIZED TESTBANK. Includes over 900 questions in multiple-choice format so you can assess student comprehension.

IMAGE LIBRARY. Includes over 200 images from the textbook to create your own transparency masters or to customize your own PowerPoint slides. The Image Library comes with the ability to browse and search images with key words and allows quick and easy use.

ONLINE COMPANION

The text has a companion website at www.electronictech.delmar.cengage.com, which will have high appeal to both educators and students. The Online Companion provides access to text updates.

ABOUT THE AUTHOR

- Associate Professor, Emeritus at the State University of New York at Oswego where he taught Electronics Technology.

- Has 23 years experience in public education as a teacher and administrator.
- Retired from the US Navy as an Electronics Technician Senior Chief.
- Member of the International Technology Education Association, New York State Technology Education Association and the International Graphic Arts Education Association.
- President of TEK Prep, a small business that does education consulting.
- As an education consultant, he teaches courses in South Carolina and Florida.

ACKNOWLEDGMENTS

I would like to thank John Millhouse, a retired Navy Chief Electronics Technician who served with me aboard the *USS Proteus AS-19*, a Fleet Ballistic Missile Submarine Tender. He has retired and now works as a consultant Electronics Engineer in Florida. He helped with the MultiSIM examples and sample problems used throughout the text.

I would also like to thank both Avi Hadar, owner of Kelvin Electronics, for his help and Duane Rupert, who was supportive of the content development and the concept of the book when we were at Greece Central School.

I would like to recognize Chery Scholand, a retired Mathematics teacher at Greece Central School whose help made this revision possible, and to recognize Gerald Buss, retired President of EIC Electronics, who provided me with help and support from the industrial sector.

Thanks are also due to the numerous teachers who continue to use the text and have identified areas to include, expand, or improve.

The author and Delmar, Cengage Learning wish to thank the reviewers for their suggestions

and comments during development of this edition. Thanks go to the following:

Richard Portwine, Southern Maine
Technical College, South Portland, ME

Donald Hofmann, Grayson County College,
Denison, TX 75020

Russell Bonine, Southwestern College, San
Diego, CA

James Knowles, Community College of
Rhode Island, Warwick, RI

Murray Stocking, Ferris State University,
Big Rapids, MI

Clifton Ray Morgan, Northwest Kansas
Technical College, Goodland, KS

Finally, I would like to thank my wife, Shirley,
who has supported me in the development of this
edition of the text.

Earl D. Gates
Oswego, New York
2006

CAREERS IN ELECTRONICS

Many exciting career opportunities exist in the electrical/electronics field. A sample of these available opportunities are provided in the following information. Check for other career opportunities at the career information center in your school or community.

AUTOMATION MECHANIC

An automation mechanic maintains controllers, assembly equipment, copying machines, robots, and other automated or computerized devices. A person with this job installs, repairs, and services machinery with electrical, mechanical, hydraulic, or pneumatic components. Precision measuring instruments, test equipment, and handtools are used. A knowledge of electronics and the ability to read wiring diagrams and schematics are required.

Becoming an automation mechanic requires formal training, which is offered by the military, junior/community colleges, vocational-technical schools, and in-house apprenticeship programs. Although most training is provided through formal classroom instruction, some of the training may only be obtained through on-the-job training.

Automation mechanic is one of the fastest growing vocations in the industry. This rapid growth is expected to continue annually.

AUTOMOTIVE MECHANIC

There are currently more computers aboard today's automobile than aboard our first spaceship. A typical automobile contains approximately ten to fifteen computers that operate everything from the engine and radio to the driver's seat. As

a result, automotive mechanics now need a greater knowledge of electronics.

To be able to distinguish an electronic malfunction from a mechanical malfunction, automotive mechanics must be familiar with the minimum of the basic principles of electronics. In addition, they must be able to test and replace electronic components.

Becoming an automotive mechanic requires formal training, which is offered by the military, junior/community colleges, vocational-technical schools, and in-house apprenticeship programs. Although most training is provided through formal classroom instruction, some of the training may be obtained only through on-the-job training. To reduce the amount of time invested in training a prospective mechanic, more employers are now looking for people who have completed a formal automotive training program.

Employment opportunities are good for automotive mechanics who have completed an automotive training program. People whose training includes basic electronics skills will have the best opportunities. Employment growth is expected to increase at a normal rate annually with a concentration in automobile dealerships, independent automotive repair shops, and specialty car-care chains. Employment in gasoline service stations will continue to decline as fewer stations will offer repair services.

COMPUTER TECHNICIAN

A computer technician installs, maintains, and repairs computer equipment and systems. Initially, the computer technician is responsible for laying cables and making equipment con-

nections. This person must thoroughly test the new system(s), resolving all problems before the customer uses the equipment. At regular intervals, the computer technician maintains the equipment to ensure that everything is operating efficiently. A knowledge of basic and specialized test equipment and handtools is necessary.

Computer technicians spend much of their time working with people—listening to complaints, answering questions, and sometimes offering advice on both equipment system purchases and ways to keep equipment operating efficiently. Experienced computer technicians often train new technicians and sometimes have limited supervisory roles before moving into a supervisory or service managerial position.

A computer technician is required to have one or two years of training in basic electronics or electrical engineering from a junior college, college or vocational training center, or military institution. The computer technician must be able to keep up with all the new hardware and software.

Projections indicate that employment for computer technicians will be high. The nation's economy is expanding, so the need for computer equipment will increase; therefore, more computer technicians will be required to install and maintain equipment. Many job openings for computer technicians may develop from the need to replace technicians who leave the labor force, transfer to other occupations or fields, or move into management.

COMPUTER ENGINEERS

The rapid growth in computers has generated a demand for people trained in designing new hardware and software systems and incorporating new technologies into existing and new systems. These trained professionals are known as computer engineers and system analysts.

Computer engineers can be further broken down into hardware and software engineers. Computer hardware engineers design, develop, test, and supervise the manufacturing of computer hardware. Computer software engineers design and develop software systems for control and automation of manufacturing, business, and management processes. They also may design and develop software applications for consumer use at home or create custom software applications for clients.

There is no universally accepted preparation for a computer professional because the job often depends on the work that needs to be done. Most employers require that employees have at least a bachelor's degree. However, a passion for computers and proficiency in advanced computer skills will at times win out over a bachelor's degree.

This field is one of the fastest-growing fields. Technological advances are occurring so rapidly in the computer field that employers are struggling to keep up with trained professionals. As the technology becomes more sophisticated and complex, more expertise and a higher level of skills will be required. A continual learning process must be undertaken to keep up. College graduates with a bachelor's degree in computer science, computer engineering, information science, or information systems will enjoy favorable employment opportunities.

ELECTRICAL ENGINEER

Electrical engineers make up the largest branch of engineering. An electrical engineer designs new products, writes performance specifications, and develops maintenance requirements. Electrical engineers also test equipment and solve operating problems within a system, and predict how much time a project will require. Then, based on the time estimate, the electrical engineer determines how much the project will cost.

The electrical engineering field is divided into two specialty groups: electrical engineering and electronic engineering. An electrical engineer

works in one or more areas of power-generating equipment, power-transmitting equipment, electric motors, machinery control, and lighting and wiring installation. An electronics engineer works with electronic equipment associated with radar, computers, communications, and consumer goods.

The number of engineers in demand is expected to increase annually. This projected growth is attributed to an increase in demand for computers, communication equipment, and military equipment. Additional jobs are being created through research and development of new types of industrial robot control systems and aviation electronics. Despite this rapid growth, a majority of openings will result from a need to replace electrical and electronics engineers who leave the labor force, transfer to other occupations or fields, or move into management.

ELECTRICIAN

An electrician may specialize in construction, maintenance, or both. Electricians assemble, install, and maintain heating, lighting, power, air-conditioning, and refrigeration components. The work of an electrician is active and sometimes strenuous. An electrician risks injury from electrical shock, falls, and cuts from sharp objects. To decrease the risk of these job-related hazards, an electrician is taught to use protective equipment and clothing to prevent shocks and other injuries. An electrician must adhere to the *National Electrical Code (NEC)*^{®*} specifications and procedures, as well as to the requirements of state, county, and municipal electric codes.

A large proportion of electricians are trained through apprenticeship programs. These programs are comprehensive, and people who com-

plete them are qualified for both maintenance and construction work. Most localities require that an electrician be licensed. To obtain the license, electricians must pass an examination that tests their knowledge of electrical theory, the *National Electrical Code*[®], and local electrical and building codes. After electricians are licensed, it is their responsibility to keep abreast of changes in the *National Electrical Code*[®], with new materials, and with methods of installation.

Employment for an electrician is expected to increase annually. As population increases and the economy grows, more electricians will be needed to maintain the electrical systems used in industry and in homes. Additionally, as both new and old homes are prepared for new technologies to make them smarter, the demand will require more electricians who are trained in the new technologies.

ELECTRONICS TECHNICIAN

Electronics technicians develop, manufacture, and service electronic equipment and they use sophisticated measuring and diagnostic equipment to test, adjust, and repair electronic equipment. This equipment includes radio, radar, sonar, television, and computers, as well as industrial and medical measuring and controlling devices.

One of the largest areas of employment for electronics technicians is in research and development. Technicians work with engineers to set up experiments and equipment and calculate the results. They also assist engineers by making prototypes of newly developed equipment, as well as by performing routine design work. Some electronics technicians work as sales or field representatives to give advice on installation and maintenance of complex equipment. Most electronics technicians work in laboratories, electronics shops, or industrial plants. Ninety percent of electronics technicians work in private industry.

**National Electrical Code (NEC)*[®] are registered trademarks of the National Fire Protection Association, Inc., Quincy, MA.

Becoming an electronics technician requires formal training, which is offered by the military, junior/community colleges, vocational-technical schools, or in-house apprenticeship programs.

Employment of electronics technicians is expected to increase annually due to an increased de-

mand for computers, communication equipment, military electronics, and electronic consumer goods. Increased product demand will provide job opportunities, but the need to replace technicians who leave the labor force, transfer to other occupations or fields, or move into management may also increase.

USING A CALCULATOR

Due to a decrease in cost, the handheld electronic calculator are very popular. Many students have rejoiced that all of their mathematical work is now mastered. In just a few keystrokes, a calculator will give the correct answer. However, students fail to realize that a calculator is just a tool to perform calculations very quickly, but with no guarantees for a correct answer. A calculator gives the correct answer only when the correct numbers are entered, in the correct order, and with the correct function keys used at the appropriate time.

If operators do not understand principles of the mathematical process, they will not be able to properly enter data into a calculator, nor will they be able to correctly interpret the results. Mathematical skills still count. Even when all data is entered correctly, the answer may be incorrect due to battery failure or other conditions.

Selecting a calculator appropriate for electronics is an important decision. The marketplace is flooded with many makes and models. Which is the right one? What are the functions that will prove to be the most useful? For this course, choose one that has the following functions: $+$, $-$, \times , \div , $1/x$, x^2 , and $\sqrt{\quad}$. A memory function is optional. Scientific and programmable calculators have become popular. Although they are not needed for this textbook, they typically include formulas and functions used in trigonometry and statistics. If you decide to purchase one, study the manual carefully so you may use the calculator to its fullest extent. All calculators generally come with a manual, which should be kept handy.

The following examples show how a calculator is used to solve various types of problems in electronics. Turn on your calculator. Examine the keyboard. Let's do some calculating.

ADDITION

EXAMPLE 1 Add: $39,857 + 19,733$

Solution:

Enter	Display
39857	39857
+	39857
19733	19733
=	59590

SUBTRACTION

EXAMPLE 2 Subtract: $30,102 - 15,249$

Solution:

Enter	Display
30102	30102
-	30102
15249	15249
=	14853

MULTIPLICATION

EXAMPLE 3 Multiply: $33,545 \times 981$

Solution

Enter	Display
33545	33545
\times	33545
981	981
=	32907645

DIVISION

EXAMPLE 4 Divide: 36,980 by 43 or $36,980$
or $43 \div 36,980$ 43

Solution

Enter	Display
36980	36980
\div	36980
43	43
=	860

SQUARE ROOT

EXAMPLE 5 Find the square root of 35,721

Solution

Enter	Display
35721	35721
$\sqrt{}$	189

TOTAL RESISTANCE (PARALLEL CIRCUIT)

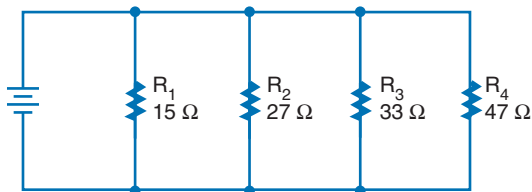
The total resistance of a parallel circuit may be calculated by first computing the reciprocal of each branch and then taking the reciprocal of the branch total.

Parallel circuits are made up of resistors that are sold in resistance values of ohms. Calculating parallel circuit total resistance involves the use of reciprocals ($1/R$) as shown in the parallel circuit formula:

$$\frac{1}{R_T} = \frac{1}{R_1} + \frac{1}{R_2} + \frac{1}{R_3} \cdots + \frac{1}{R_n}$$

A calculator gives the reciprocal of a number by simply pressing the $1/X$ key. If the calculator does not have a $1/X$ key, then each reciprocal value will be found separately by dividing 1 by the resistance value.

EXAMPLE 6 Calculate the total equivalent resistance of the parallel circuit shown



Solution

	Enter	Display
Reciprocal of R_1	15	15
	$1/X$	0.0666667

Reciprocal of R_2	27	27
	$1/X$	0.037037
Reciprocal of R_3	33	33
	$1/X$	0.030303
Reciprocal of R_4	47	47
	$1/X$	0.0212766
	Enter	Display
Totals of reciprocals	0.0666667	0.0666667
	+	
	0.037037	0.1037037
	+	
	0.030303	0.1340067
	+	
	0.0212766	0.1552833
	Enter	Display
Reciprocal of totals	0.1552833	0.1552833
	$1/X$ 6.4398425	Round answer to 6.44 Ω

EXAMPLE 7 Using a calculator with memory function

Solution

	Enter	Display
Reciprocal of R_1	15	15
	$1/X$	0.0666667
	M+	0.0666667 M
	C	0
Reciprocal of R_2	27	27
	$1/X$	0.037037
	M+	0.037037 M
	C 0	
Reciprocal of R_3	33	33
	$1/X$	0.030303
	M+	0.030303 M
	C	0
Reciprocal of R_4	47	47
	$1/X$	0.0212766
	M+	0.0212766 M
	C	0
Totals of reciprocals	RM	0.0.155283329
Reciprocal of totals	$1/X$	6.439841299
	Round answer to 6.44 Ω	

ROUNDING

Note: Rounding is not a calculator function and must be done mentally. The number of significant digits can be reduced by *rounding off*. This means dropping the least significant digits until the desired number of digits remain. The new least significant digit may be changed using the following rules:

If the highest significant digit dropped is

- less than 5, the new significant digit is not changed.
- greater than 5, the new significant digit is increased by one.

- 5, the new significant digit is not changed if it is even.
- 5, the new significant digit is increased by one if it is odd.

EXAMPLE Round 352.580

Round to the nearest tenth	352.6
Round to the nearest whole number	352
Round to the nearest hundred	400

These rules result in a rounding off technique that on the average gives the most consistent reliability.

SAFETY PRECAUTIONS

The following safety precautions are not intended as a replacement for information given in class or lab manuals. If at any time you question what steps or procedures to follow, consult your teacher.

GENERAL SAFETY PRECAUTIONS

Because of the possibility of personal injury, danger of fire, and possible damage to equipment and materials, all work on electrical and electronic circuits should be conducted following these basic safety procedures.

1. *Remove power from the circuit or equipment prior to working on it.* Never override interlock safety devices. Never assume the circuit is off; check it with a voltmeter.
2. *Remove and replace fuses only after the power to the circuit has been deenergized.*
3. *Make sure all equipment is properly grounded.*
4. *Use extreme caution when removing or installing batteries containing acid.*
5. *Use cleaning fluids only in well-ventilated spaces.*
6. *Dispose of cleaning rags and other flammable materials in tightly closed metal containers.*
7. *In case of an electrical fire, deenergize the circuit and report it immediately to the appropriate authority.*

HIGH VOLTAGE SAFETY PRECAUTIONS

As people become familiar with working on circuits, it is human nature to become careless with routine procedures. Many pieces of electrical equipment use voltages that are dangerous and can be fatal if contacted. The following precau-

tions should be followed at all times when working on or near high-voltage circuits:

1. *Consider the result of each act.* There is absolutely no reason for individuals to take chances that will endanger their life or the lives of others.
2. *Keep away from live circuits.* Do not work on or make adjustments with high voltage on.
3. *Do not work alone.* Always work in the presence of another person capable of providing assistance and first aid in case of an emergency. People who are considering a career working in the electricity and electronics field should become CPR certified.
4. *Do not tamper with interlocks.*
5. *Do not ground yourself.* Make sure you are not grounded when making adjustments or using measuring instruments. Use only one hand when connecting equipment to a circuit. Make it a practice to put one hand in your rear pocket.
6. *Use an isolation transformer when working on AC-powered circuits/equipment.* An isolation transformer isolates the circuit/equipment from the power source, adding an additional safety factor.
7. *Never energize equipment in the presence of water leakage.*

PERSONAL SAFETY PRECAUTIONS

Take time to be safe when working on electrical and electronic circuits. Do not work on any circuits or equipment unless the power is secured.

1. *Work only in clean, dry areas.* Avoid working in damp or wet locations because the resistance

of the skin will be lower; this increases the chance of electrical shock.

2. *Do not wear loose or flapping clothing.* Not only may it get caught, but it might also serve as a path for the conduction of electricity.
3. *Wear only nonconductive shoes.* This will reduce the chance of electrical shock.
4. *Remove all rings, wristwatches, bracelets, ID chains and tags, and similar metal items.* Avoid clothing that contains exposed metal zippers, buttons, or other types of metal fasteners. The metal can act as a conductor, heat up, and cause a bad burn.
5. *Do not use bare hands to remove hot parts.*
6. *Use a shorting stick to remove high-voltage charges on capacitors.* Capacitors can hold a charge for long periods of time and are frequently overlooked.
7. *Make certain that the equipment being used is properly grounded with polarized plugs.* Ground all test equipment to the circuit and/or equipment under test.
8. *Remove power to a circuit prior to connecting alligator clips.* Handling uninsulated alligator clips could cause potential shock hazards.
9. *When measuring voltages over 300 volts, do not hold the test prods.* This eliminates the possibility of shock from leakage on the probes.

Safety is everyone's responsibility. It is the job of everybody in and out of class to exercise proper precautions to ensure that no one will be injured and no equipment will be damaged.

Every class in which you work should emphasize and practice safety.

FIRE SAFETY

There are three categories of fire, with each requiring special extinguishing techniques.

- Class A Combustible materials such as wood, paper, or cloth. Extinguish this type of fire by cooling it with water or smothering it with a CO₂ (carbon dioxide) extinguisher.

- Class B Flammable liquids such as gasoline, kerosene, greases, or solvents. Extinguish by smothering with foam or CO₂ extinguisher.

- Class C Electrical equipment. Extinguish by removing power source and use nonconducting dry power or CO₂ extinguisher.

ELECTRICAL SHOCK

A major hazard when working with electricity and electronic circuits is electrical shock. Electrical shock occurs when an electric current flows through the body when a complete circuit exists. Different levels of current produce the following results:

- | | |
|-----------------------|--|
| 0.001 Ampere (1 mA) | A mild tingling sensation that can be felt. |
| 0.010 Ampere (10 mA) | Start to lose muscular control. |
| 0.030 Ampere (30 mA) | Breathing becomes upset and labored. Muscular paralysis. |
| 0.100 Ampere (100 mA) | Death if the current lasts for more than a second. |
| 0.200 Ampere (200 mA) | Severe burns, breathing stops. Death. |

One technique to reduce current flow is to increase body resistance. Body resistance is high when the skin moisture content is low with no cuts or abrasions at the point of electrical contact. In these situations, very little current will flow, with a mild shock resulting.

If the situation were reversed with high skin moisture content, lowering the body resistance, a large current would flow. If the current flows through the chest region, the heart could go into ventricular fibrillation, resulting in rapid and ir-

regular muscle contractions and leading to cardiac arrest and respiratory failure.

The factors that influence the effects of electrical shock include:

- Intensity of the current
- Frequency of the current
- Current path through the body
- Length of time current passes through the body

Remember, it is the amount of current flow through the body, not the amount of voltage contacted, that determines the severity of a shock. The larger the current through the body, the greater the effect of the shock.

FIRST AID

With severe electrical shock, do not become part of the problem. First, send for help; then remove the source of power. Do not attempt to touch or pull the victim away without removing the power source or you will also get yourself shocked.

If the power source cannot be secured, use a nonconducting material to remove the victim from the circuit. Once the victim is free, check for signs of breathing and pulse. If trained, begin CPR (cardiopulmonary resuscitation) if necessary.

HAZARDOUS CHEMICALS

Concerns with hazardous chemicals include breathing vapors, contact with skin and eyes, injecting liquids, and danger of fire or explosions. Chemicals found in the electronics laboratory include adhesives, cleaning solvents, etching solutions, photographic developing solutions, screenprinting developing and cleaning solutions, solder fumes, and spray paints.

Observe the following safety practices when working with chemicals:

1. Always wear safety glasses when working with hazardous chemicals.
2. Wear protective rubber/vinyl gloves when working with acids.
3. Use tongs when handling printed circuits being etched.
4. Read the label on all chemicals being used.
5. Work in a well-ventilated space.
6. Wash all tools that contact any hazardous chemical.
7. Always label containers with chemicals.
8. Do not store chemicals in glass containers if possible.
9. Store all chemicals in a flammable metal storage cabinet.

In case of contact with a hazardous chemical, read the label and follow instructions and send for expert medical help.

Various hazardous materials are used throughout the electronics industry. These materials are clearly identified and classified through the MSDS system. Handling and disposing procedures and information can be obtained from specific manufacturer's websites or through many online resources, such as <http://www.ilpi.com/msds/> and <http://www.msdssearch.com>

ELECTROSTATIC DISCHARGE (ESD)

Static electricity is an electrical charge at rest on a surface. The static charge becomes larger through the action of contact and separation or by motion. The electrostatic discharge takes place when the charged body comes near or touches a neutral surface.

A surface can become charged through three means. The most common means is an electrical charge generated by friction. Rubbing two dissimilar materials together will generate an electrical charge. Walking across a floor or removing a garment will develop a voltage in excess of 5000 volts. It takes approximately 5000 volts to jump approximately 1/4 of an inch.

Induction is a second means of developing a charge. When a person handles a printed circuit board or electronic component wrapped in a plastic material, they induce a charge into the contents of the plastic wrap. When another person removes the plastic wrap, the sudden discharge results in ESD damage.

Capacitance is the third means of generating a static charge. Capacitance is inversely related to the distance between two surfaces. A low voltage can become harmful as one surface is removed further from the other surface or ground. When a circuit is picked up from a table its relative capacitance decreases and voltage increases. When the circuit is grounded again, damage will occur by the large voltage discharging that was generated when the circuit was originally lifted.

Metal oxide semiconductors (MOSSs) are extremely sensitive to static charges, as are CMOSs, FETs, VLSI ICs, NMOSs, PMOSs, Schottky diodes, and ECL and linear ICs devices.

High humidity can increase surface conductivity, which reduces friction-generated static electricity. The increased humidity spreads the charge over a larger surface area, reducing the field intensity, and allows the charge to bleed off to ground.

Manufacturers have designed protective circuitry to help dissipate ESD using zener diodes and limiting resistors.

ESD prevention requires the awareness and practice of the following procedures.

1. Treat all electronic components and circuits as static sensitive.
2. Do not touch the leads, pins, or components of printed circuit board traces.
3. Before handling a component or circuit, discharge yourself by touching a grounded metal surface.
4. Keep components in original packing materials until needed.
5. Never slide static components over any surface.

HAND TOOLS

When using hand tools, always observe the following precautions:

1. Always use the proper tool for the job. Use the right type and size tool for each application.
2. When carrying tools, always keep the cutting edge down.
3. Keep hands clean when using tools. Avoid grease, dirt, or oil on hands when using any tool.
4. Clamp small pieces when using a hacksaw, screwdriver, or soldering iron.
5. Avoid using chisels and punches with mushroomed heads.
6. Never use a file without a handle.
7. Never use plastic-handled tools near an open flame.
8. Keep metal rules clear of electrical circuits.
9. Disconnect all electrical devices by pulling directly on the plug, never the cord.
10. When cutting wire, always cut one wire at a time to avoid damaging the cutting tool.

POWER TOOLS

When using power tools, always observe the following precautions:

1. Only the operator starts or stops a machine. When stopping a machine, wait until it comes to a complete stop before leaving the machine.
2. Make all adjustments to the machine prior to turning it on.
3. Never have any loose hand tools, rags, or brushes in the work area when applying power.
4. Keep all safety guards in their proper position at all times.
5. Never force a cutting or drilling tool into a workpiece.

6. Only one person in the work zone at all times power is applied.
7. Have instructor check any special setups prior to applying power.
8. Use only grounded power tools with three-prong plugs or UL (Underwriters Laboratories) -approved housing power tools.

SOLDERING

When soldering, always observe the following precautions:

1. Always assume the soldering iron is hot. Never touch the tip to see if it is hot.
2. Always place the soldering iron in its holder when idling.
3. Never shake excess solder off the tip; wipe it on a damp sponge or approved tip cleaner.
4. Never pass a soldering iron to another person; place it in the holder and let the other person take it from there.
5. Never solder on a circuit that has power applied to it.
6. Always use a grounded-tip soldering iron.

STANDARDS

An Underwriters Laboratories (UL) label on a device implies that the product bearing the label is safe for use as intended. Tests completed

by Underwriters Laboratories determine if a product meets the minimum safety standards. When purchasing a product, check to determine if it has the UL label on it. The UL label has nothing to do with the quality of a product, only its safety.

The Canadian Standard Association (CSA) is similar to the UL safety test. It also has very strict safety codes. The CSA label appears on all types of products, including electrical products. CSA also does on-site inspections of manufacturers on a frequent basis.

If a device has both the UL and CSA labels on it, it can be assumed that the device is safe.

A number of insurance companies have formed a group known as the National Fire Protection Association. Every few years, this group publishes a summary of electrical-wiring codes under the general heading of the *National Electrical Code* (NEC).[®] The purpose of this code is to provide guidelines for safe wiring practices in residential and commercial buildings. State and local municipalities may require even more stringent codes than the NEC that must be followed. In many states all wiring must be done or approved by a master electrician. These codes are published for both your own and your neighbor's protection. Electrical fires can and do happen and they can spread to adjacent homes or apartments. The NEC guidebook helps to minimize electrical fires and to provide safety when doing electrical wiring.

This page intentionally left blank

SECTION 1

DC Circuits



CAREER PROFILE

Edward M. Livingston



TITLE

Airborne Communications Systems Operator—MC-13E Talon I

ORGANIZATION

711th Special Operations Squadron
Duke Field, Florida
U.S. Air Force

BACKGROUND

Sergeant Livingston entered the U.S. Air Force as a reservist at Duke Field in April 1976, after having completed a four-year tour of duty in the U.S. Marine Corps, where he served as an aviation electronics technician on the Douglas A-4 Skyhawk. During his time in the marine corps and later in the Air Force Reserve, Sergeant Livingston completed numerous technical courses that include: aviation electronics technician, aviation radar maintenance, and aviation communication and navigation systems. This specialized training in the field of electronics allowed Sergeant Livingston numerous promotions; he rose in rank from a private in the marine corps to a First Sergeant in the Air Force Reserve.

JOB REQUIREMENTS

Specialized training in electronics as it relates to military applications (supplemented by on-the-job training).

ON THE JOB

A typical day on the job consists of preparing the electronic communication systems on the MC-13E Talon I aircraft for operation under all potential conditions, reviewing communication procedures with other members of the aircrew, actually operating the communication systems in both training and live-combat settings, troubleshooting systems, and training less experienced technicians in his squadron. But some days can be more exciting than others. Sergeant Livingston served with the Joint Special Operations Air Component in Operation Iraqi Freedom. During a routine training mission out of Duke Field, Florida, Sergeant Livingston noticed a derailed train near the city of Crestview, Florida. While his aircraft circled the train wreck, Sergeant Livingston noticed that one of the train cars was leaking gas. Applying his electronic communication skills, Sergeant Livingston quickly notified civilian authorities of the need for a quick evacuation of the area. Moments after all peo-

ple were evacuated from the danger zone, the leaking train car exploded. On this “day on the job,” Sergeant Livingston saved the lives of several people on the ground and was awarded the Air Force Commendation medal for his quick thinking and subsequent actions.

UPSIDE

What Sergeant Livingston likes best about his job is knowing that he is helping to keep America free and Americans safe. The job is exciting, and it allows him to travel and see new and different people and places. It also allows him to make an important contribution to society.

DOWNSIDE

Like any person in the military, Sergeant Livingston must be prepared to deploy to combat in “hot spots” all over the world—sometimes at short notice.

OPPORTUNITIES

There are many opportunities for electronics technicians in all branches of the military. The various branches of the military need the same types of electronics technicians that civilian employers need, including avionics technicians, biomedical electronics technicians, ground transportation electronics technicians, calibration and instrumentation technicians, television/radio/audio-visual electronics technicians, computer hardware technicians, electronics engineering technologists, electrical/electronics drafting technicians, and equipment installation/maintenance/repair technicians, to name just a few.

WORDS OF ADVICE

Get a solid background in basic electronics before joining the military. This background will help when you attend various specialized “tech schools” in the military. Then be prepared to continue learning for the rest of your life as electronic technologies continue to improve and change.

Fundamentals of Electricity

OBJECTIVES

After completing this chapter, the student will be able to:

- Define *atom*, *matter*, *element*, and *molecule*.
- List the parts of an atom.
- Define the *valence shell* of an atom.
- Identify the unit for measuring current.
- Draw the symbol used to represent current flow in a circuit.
- Describe the difference between conductors, insulators, and semiconductors.
- Define *difference of potential*, *electromotive force*, and *voltage*.
- Draw the symbol used to represent voltage.
- Identify the unit used to measure voltage.
- Define *resistance*.
- Identify characteristics of resistance in a circuit.
- Identify the unit for measuring resistance.
- Draw the symbol used to represent resistance in a circuit.



See accompanying CD for interactive presentations and tutorials relating to Chapter 1.

Everything, whether natural or man-made, can be broken down into either an element or a compound. However, the smallest part of each of these is the atom.

The atom is made up of protons, neutrons, and electrons. The protons and neutrons group together to form the center of the atom called the

nucleus. The electrons orbit the nucleus in shells located at various distances from the nucleus.

When appropriate external force is applied to electrons in the outermost shell, they are knocked loose and become free electrons. The movement of free electrons is called current. The external force needed to create this current is called voltage.

As it travels along its path, the current encounters some opposition, called resistance.

This chapter looks at how current, voltage, and resistance collectively form the fundamentals of electricity.

1-1 MATTER, ELEMENTS, AND COMPOUNDS

Matter is anything that occupies space and has weight. It may be found in any one of three states: solid, liquid, or gas. Examples of matter include the air we breathe, the water we drink, the clothing we wear, and ourselves. *Matter* may be either an element or a compound.

An **element** is the basic building block of nature. It is a substance that cannot be reduced to a simpler substance by chemical means. There are

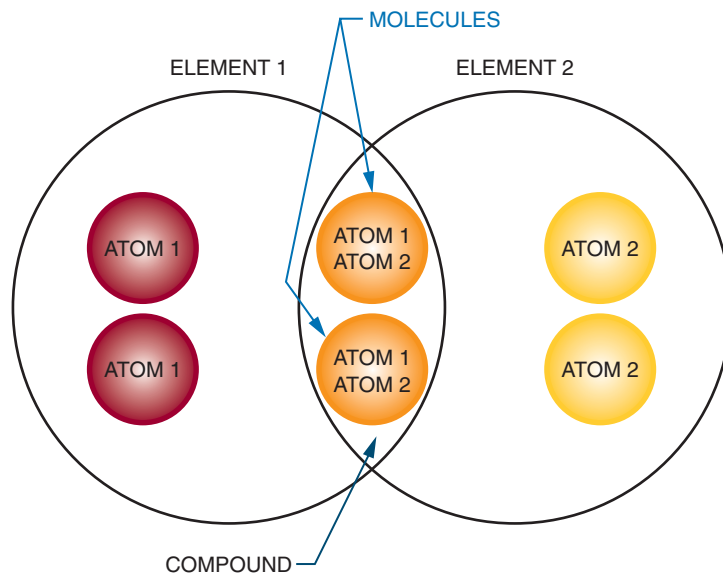
now over 100 known elements (Appendix 2). Examples of elements are gold, silver, copper, and oxygen.

The chemical combination of two or more elements is called a **compound** (Figure 1-1). A *compound* can be separated by chemical but not by physical means. Examples of compounds are water, which consist of hydrogen and oxygen, and salt, which consists of sodium and chlorine. The smallest part of the compound that still retains the properties of the compound is called a **molecule**. A *molecule* is the chemical combination of two or more atoms. An **atom** is the smallest particle of an element that retains the characteristic of the element.

The physical combination of elements and compounds is called a **mixture**. Examples of *mixtures* include air, which is made up of oxygen, nitrogen, carbon dioxide, and other gases, and salt water, which consists of salt and water.

FIGURE 1-1

The chemical combination of two or more elements is called a compound. A molecule is the chemical combination of two or more atoms. Examples are water (H_2O) and salt ($NaCl$).



1-1 QUESTIONS

1. In what forms can matter be found?
2. What is a substance called that cannot be reduced to a simpler substance by chemical means?
3. What is the smallest possible particle that retains the characteristic of a compound?
4. What is the smallest possible particle that retains the characteristic of an element?

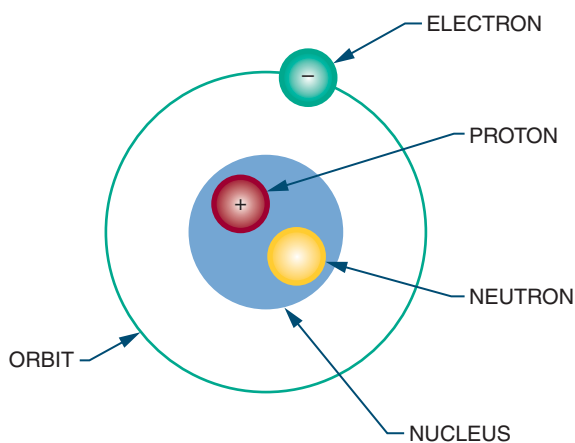
1-2 A CLOSER LOOK AT ATOMS

As previously stated, an *atom* is the smallest particle of an *element*. Atoms of different elements differ from each other. If there are over 100 known elements, then there are over 100 known atoms.

Every atom has a **nucleus**. The *nucleus* is located at the center of the atom. It contains positively charged particles called **protons** and uncharged particles called **neutrons**. Negatively charged particles called **electrons** orbit around the nucleus (Figure 1-2).

FIGURE 1-2

Parts of an atom.



The number of *protons* in the nucleus of the atom is called the element's **atomic number**. Atomic numbers distinguish one element from another.

Each element also has an atomic weight. The **atomic weight** is the mass of the atom. It is determined by the total number of protons and neutrons in the nucleus. Electrons do not contribute to the total mass of the atom; an electron's mass is only 1/1845 that of a proton and is not significant enough to consider.

The electrons orbit in concentric circles about the nucleus. Each orbit is called a **shell**. These *shells* are filled in sequence; K is filled first, then L, M, N, and so on (Figure 1-3). The maximum number of electrons that each shell can accommodate is shown in Figure 1-4.

The outer shell is called the **valence shell** and the number of electrons it contains is the **valence**. The farther the *valence shell* is from the nucleus, the less attraction the nucleus has on each valence electron. Thus the potential for the atom to gain or lose electrons increases if the valence shell is not full and is located far enough away from the

FIGURE 1-3

The electrons are held in shells around the nucleus.

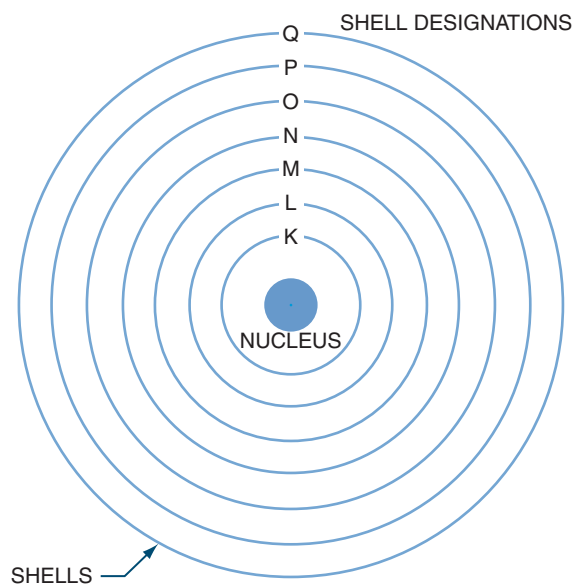


FIGURE 1-4

The number of electrons each shell can accommodate.

SHELL DESIGNATION	TOTAL NUMBER OF ELECTRONS
K	2
L	8
M	18
N	32
O	18
P	12
Q	2

nucleus. Conductivity of an atom depends on its valence band. The greater the number of electrons in the valence shell, the less it conducts. For example, an atom having seven electrons in the valence shell is less conductive than an atom having three electrons in the valence shell.

Electrons in the valence shell can gain energy. If these electrons gain enough energy from an external force, they can leave the atom and become free electrons, moving randomly from atom to atom. Materials that contain a large number of free electrons are called **conductors**. Figure 1-5

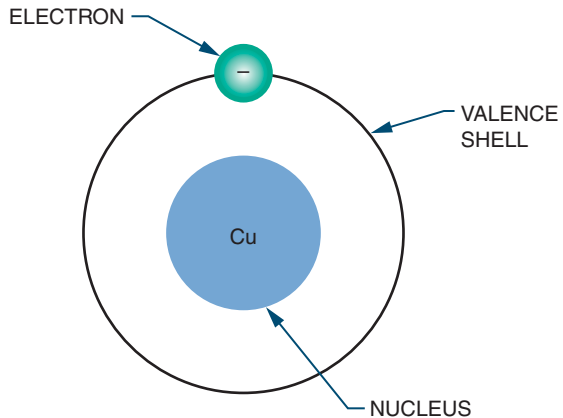
FIGURE 1-5

Conductivity of various metals used as conductors.

MATERIAL	CONDUCTANCE
Silver	High
Copper	↓
Gold	
Aluminum	
Tungsten	
Iron	
Nichrome	

FIGURE 1-6

Copper has a valence of 1.



compares the conductivity of various metals used as conductors. On the chart, silver, copper, and gold have a valence of 1 (Figure 1-6). However, silver is the best conductor because its free electron is more loosely bonded.

Insulators, the opposite of conductors, prevent the flow of electricity. *Insulators* are stabilized by absorbing valence electrons from other atoms to fill their valence shells, thus eliminating free electrons.

FIGURE 1-7

Insulation properties of various materials used as insulators.

MATERIAL	INSULATION PROPERTIES	
Mica	High	
Glass	↓	
Teflon		
Paper (Paraffin)		
Rubber		
Bakelite		
Oils		
Procelain		
Air		
		Low

Materials classified as insulators are compared in Figure 1–7. Mica is the best insulator because it has the fewest free electrons in its valence shell. A perfect insulator will have atoms with full valence shell. This means it cannot gain electrons.

Halfway between conductors and insulators are **semiconductors**. *Semiconductors* are neither good conductors nor good insulators but are important because they can be altered to function as conductors or insulators. Silicon and germanium are two semiconductor materials.

An atom that has the same number of electrons and protons is said to be electrically balanced. A balanced atom that receives one or more electrons is no longer balanced. It is said to be negatively charged and is called a **negative ion**. A balanced atom that loses one or more electrons is said to be positively charged and is called a **positive ion**. The process of gaining or losing electrons is called **ionization**. *Ionization* is significant in current flow.

1–2 QUESTIONS

1. What atomic particle has a positive charge and a large mass?
2. What atomic particle has no charge at all?
3. What atomic particle has a negative charge and a small mass?
4. What does the number of electrons in the outermost shell determine?
5. What is the term for describing the gaining or losing of electrons?

1–3 CURRENT

Given an appropriate external force, the movement of electrons is from negatively charged atoms to positively charged atoms. This flow of electrons is called **current** (I). The symbol I is used to represent current. The amount of *current* is the sum of the charges of the moving electrons past a given point.

An electron has a very small charge, so the charge of 6.24×10^{18} electrons is added together and called a **coulomb** (C). When one *coulomb* of charge moves past a single point in one second it is called an **ampere** (A). The *ampere* is named for a French physicist named André Marie Ampère (1775–1836). Current is measured in amperes.

1–3 QUESTIONS

1. What action causes current in an electric circuit?
2. What action results in an ampere of current?
3. What symbol is used to represent current?
4. What symbol is used to represent the unit ampere?

1–4 VOLTAGE

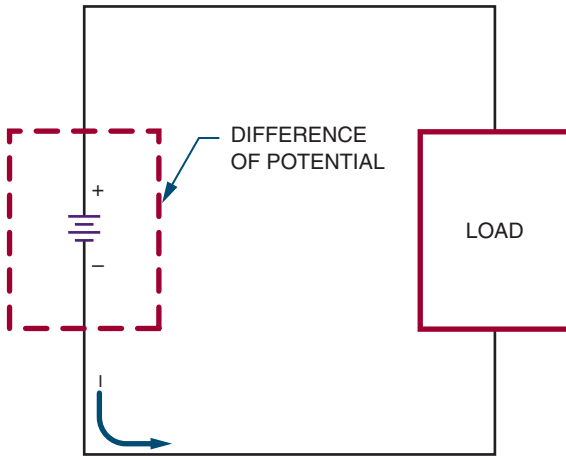
When there is an excess of electrons (negative charge) at one end of a conductor and a deficiency of electrons (positive charge) at the opposite end, a current flows between the two ends. A current flows through the conductor as long as this condition persists. The source that creates this excess of electrons at one end and the deficiency at the other end represents the **potential**. The *potential* is the ability of the source to perform electrical work.

The actual work accomplished in a circuit is a result of the **difference of potential** available at the two ends of a conductor. It is this *difference of potential* that causes electrons to move or flow in a circuit (Figure 1–8). The difference of potential is referred to as **electromotive force** (emf) or **voltage**. *Voltage* is the force that moves the electrons in the circuit. Think of voltage as the pressure or pump that moves the electrons.

The symbol **E** is used in electronics to represent voltage. The unit for measuring voltage is the **volt** (V), named for Count Alessandro Volta (1745–1827), inventor of the first cell to produce electricity.

FIGURE 1-8

Electrons flow in a circuit because of the difference of potential.



1-4 QUESTIONS

1. What force moves electrons in a circuit?
2. What is the term that represents the potential between the two ends of a conductor?
3. What symbol is used to represent voltage?
4. What symbol is used to represent the unit volt?

1-5 RESISTANCE

As the free electrons move through the circuit, they encounter atoms that do not readily give up electrons. This opposition to the flow of electrons (the current) is called **resistance** (R).

Every material offers some resistance or opposition to current flow. The degree of resistance of a material depends on its size, shape, and temperature.

Materials with a low resistance are called *conductors*. Conductors have many free electrons and offer little resistance to current flow. As previ-

ously mentioned, silver, copper, gold, and aluminum are examples of good conductors.

Materials with a high resistance are called **insulators**. Insulators have few free electrons and offer a high resistance to current flow. As previously mentioned, glass, rubber, and plastic are examples of good insulators.

Resistance is measured in **ohms**, a unit named for the German physicist George Simon Ohm (1787–1854). The symbol for the ohm is the Greek letter omega (Ω).

1-5 QUESTIONS

1. What is the term used to describe opposition to current flow?
2. What is the main difference between conductors and insulators?
3. What is the symbol used to represent resistance?
4. What is the symbol used to represent the unit of resistance?

SUMMARY

- Matter is anything that occupies space.
- Matter can be an element or compound.
- An element is the basic building block of nature.
- A compound is a chemical combination of two or more elements.
- A molecule is the smallest unit of a compound that retains the properties of the compound.
- An atom is the smallest unit of matter that retains the structure of the element.
- An atom consists of a nucleus, which contains protons and neutrons. It also has one or more electrons that orbit around the nucleus.
- Protons have a positive charge, electrons have a negative charge, and neutrons have no charge.

- The atomic number of an element is the number of protons in the nucleus.
- The atomic weight of an atom is the sum of protons and neutrons.
- The orbits of the electrons are called shells.
- The outer shell of an atom is called the valence shell.
- The number of electrons in the valence shell is called the valence.
- An atom that has the same number of protons as electrons is electrically balanced.
- The process by which atoms gain or lose electrons is called ionization.
- The flow of electrons is called current.
- Current is represented by the symbol I.
- The charge of 6,240,000,000,000,000 (or 6.24×10^{18}) electrons is called a coulomb.
- An ampere of current is measured when one coulomb of charge moves past a given point in one second.
- Ampere is represented by the symbol A.
- Current is measured in amperes.
- An electric current flows through a conductor when there is an excess of electrons at one end and a deficiency at the other end.
- A source that supplies excess electrons represents a potential or electromotive force.
- The potential or electromotive force is referred to as voltage.
- Voltage is the force that moves electrons in a circuit.
- The symbol E is used to represent voltage.
- A volt (V) is the unit for measuring voltage.
- Resistance is the opposition to current flow.
- Resistance is represented by the symbol R.
- All materials offer some resistance to current flow.
- The resistance of a material is dependent on the material's size, shape, and temperature.
- Conductors are materials with low resistance.
- Insulators are materials with high resistance.
- Resistance is measured in ohms.
- The Greek letter omega (Ω) is used to represent ohms.

CHAPTER 1 SELF-TEST

1. What criteria determine whether an atom is a good conductor?
2. What determines whether a material is a conductor, semiconductor, or insulator?
3. Why is it essential to understand the relationship between conductors, semiconductors, and insulators?
4. Explain the difference between current, voltage, and resistance.
5. Describe how the resistance of a material is determined.
6. Name one standard that can be a resource to you in evaluating the safety compliance of an electric drill?
7. Where can you determine what health hazard, if any, solder in your lab poses?
8. In comparing electronics laboratory practices with applicable MSDS information (such as soldering practices), identify changes that could be made to improve safety in the lab.

Current

OBJECTIVES

After completing this chapter, the student will be able to:

- State the two laws of electrostatic charges.
- Define *coulomb*.
- Identify the unit used to measure current flow.
- Define the relationship of amperes, coulombs, and time through a formula.
- Describe how current flows in a circuit.
- Describe how electrons travel in a conductor.
- Define and use *scientific notation*.
- Identify commonly used prefixes for powers of ten.



See accompanying CD for interactive presentations and tutorials relating to Chapter 2.

The atom has been defined as the smallest particle of an element. It is composed of electrons, protons, and neutrons.

Electrons breaking away from atoms and flowing through a conductor produce an electric current.

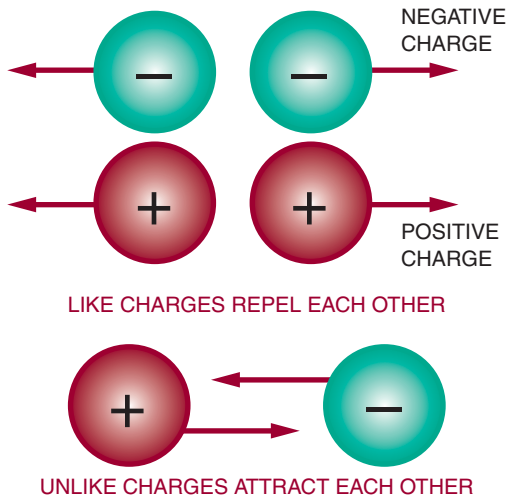
This chapter examines how electrons break free from atoms to produce a current flow and how to use scientific notation. Scientific notation expresses very large and small numbers in a form of mathematical shorthand.

2-1 ELECTRICAL CHARGE

Two electrons together or two protons together represent “like” charges. Like charges resist being brought together and instead move away from each other. This movement is called *repelling*. This is the first law of electrostatic charges: like charges repel each other (Figure 2-1). According to the second law of electrostatic charges, unlike charges attract each other.

FIGURE 2-1

Basic laws of electrostatic charges.



The negative electrons are drawn toward the positive protons in the nucleus of an atom. This attractive force is balanced by the centrifugal force caused by the electron's rotation about the nucleus. As a result the electrons remain in orbit and are not drawn into the nucleus.

The amount of attracting or repelling force that acts between two electrically charged bodies depends on two factors: their charge and the distance between them.

Single electrons have a charge too small for practical use. The unit adopted for measuring charges is the **coulomb** (C), named for Charles Coulomb. The electrical charge (Q) carried by 6,240,000,000,000,000 electrons (six quintillion, two hundred forty quadrillion, or 6.24×10^{18}) represents one *coulomb*.

$$1 \text{ C} = 6.24 \times 10^{18} \text{ electrons}$$

Electrical charges are created by the displacement of electrons. When there is an excess of electrons at one point and a deficiency of electrons at another point, a difference of potential exists between the two points. When a difference

of potential exists between two charged bodies connected by a conductor, electrons will flow along the conductor. This flow of electrons is called current.

2-1 QUESTIONS

1. What are the two laws of electrostatic charges?
2. What does an electrical charge represent?
3. Define *coulomb*.

2-2 CURRENT FLOW

An electric **current** consists of the drift of electrons from an area of negative charge to an area of positive charge. The unit of measurement for current flow is the **ampere** (A). An ampere represents the amount of current in a conductor when one coulomb of charge moves past a point in one second. The relationship between amperes and coulombs per second can be expressed as:

$$I = \frac{Q}{t}$$

where: I = current measured in amperes
 Q = quantity of electrical charge in coulombs
 t = time in seconds

EXAMPLE: What is the current in amperes if 9 coulombs of charge flow past a point in an electric circuit in 3 seconds?

Given:

$$I = ?$$

$$Q = 9 \text{ coulombs}$$

$$t = 3 \text{ seconds}$$

Solution:

$$I = \frac{Q}{t}$$

$$I = \frac{9}{3}$$

$$I = 3 \text{ amperes}$$

EXAMPLE: A circuit has a current of 5 amperes. How long does it take for one coulomb to pass a given point in the circuit?

Given:

$$\begin{aligned} I &= 5 \text{ amperes} \\ Q &= 1 \text{ coulomb} \\ t &= ? \end{aligned}$$

Solution:

$$I = \frac{Q}{t}$$

$$5 = \frac{1}{t}$$

$$\frac{5}{1} \times \frac{1}{t} \text{ (cross multiply)}$$

$$(1)(1) = (5)(t)$$

$$1 = 5t$$

$$\frac{1}{5} = \frac{5t}{5} \text{ (divide both sides by 5)}$$

$$\frac{1}{5} = t$$

$$0.2 \text{ seconds} = t$$

Electrons, with their negative charge, represent the charge carrier in an electric circuit. Therefore, electric current is the flow of negative charges. Scientists and engineers once thought

that current flowed in a direction opposite to electron flow. Later work revealed that the movement of an electron from one atom to the next created the appearance of a positive charge, called a **hole**, moving in the opposite direction (Figures 2-2, 2-3). Electron movement and current were found to be the same.

If electrons are added to one end of a conductor and provision is made to take electrons from the other end, an electric current flows through the conductor. As free electrons move slowly through the conductor, they collide with atoms, knocking other electrons free. These new free electrons travel toward the positive end of the conductor and collide with other atoms. The electrons drift from the negative to the positive end of the conductor because like charges repel. In addition, the positive end of the conductor, which represents a deficiency in electrons, attracts the free electrons because unlike charges attract.

The drift of electrons is slow (approximately an eighth of an inch per second), but individual electrons ricochet off atoms, knocking other electrons loose, at the speed of light (186,000 miles per second). For example, visualize a long, hollow tube filled with Ping-Pong balls (Figure 2-4). As a ball is added to one end of the tube, a ball is forced out the other end of the tube. Although an indi-

FIGURE 2-2

As electrons move from one atom to another, they create the appearance of a positive charge, called a hole.

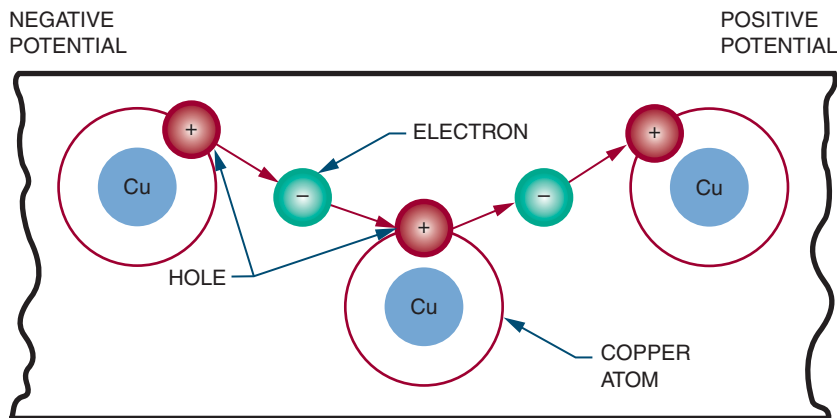


FIGURE 2-3

Electron movement occurs in the opposite direction to hole movement.

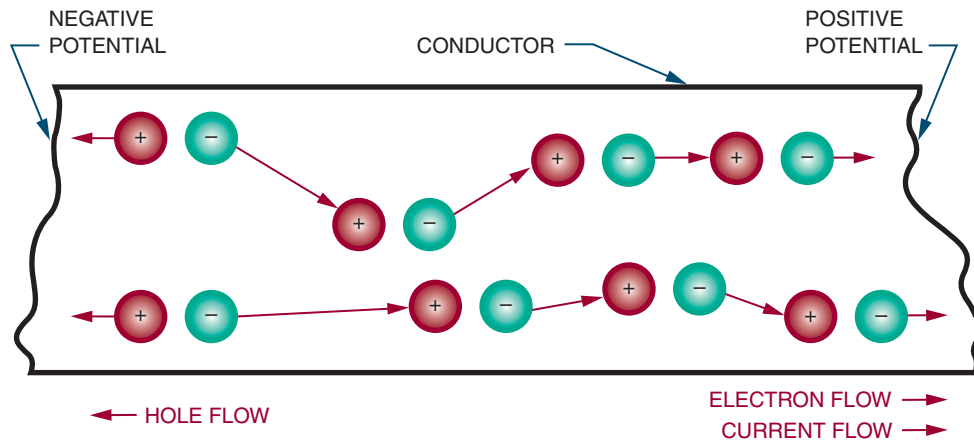
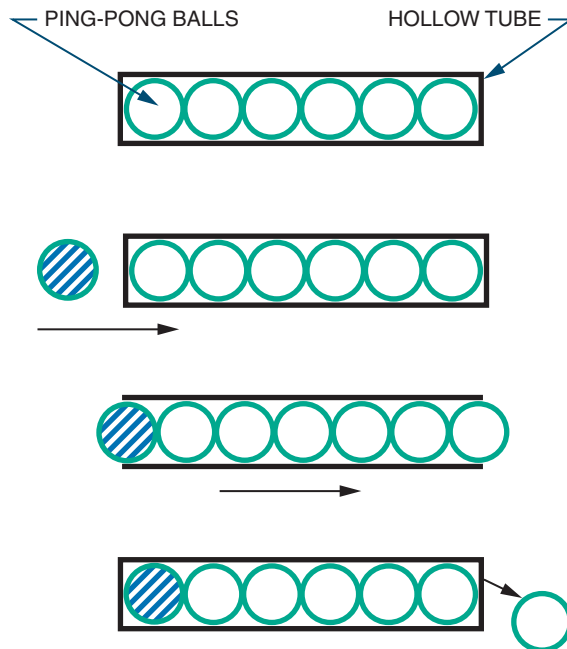


FIGURE 2-4

Electrons in a conductor react like Ping-Pong balls in a hollow tube.



vidual ball takes time to travel down the tube, the speed of its impact can be far greater.

The device that supplies electrons from one end of a conductor (the negative terminal) and re-

moves them from the other end of the conductor (the positive terminal) is called the *voltage source*. It can be thought of as a kind of pump (Figure 2-5).

2-2 QUESTIONS

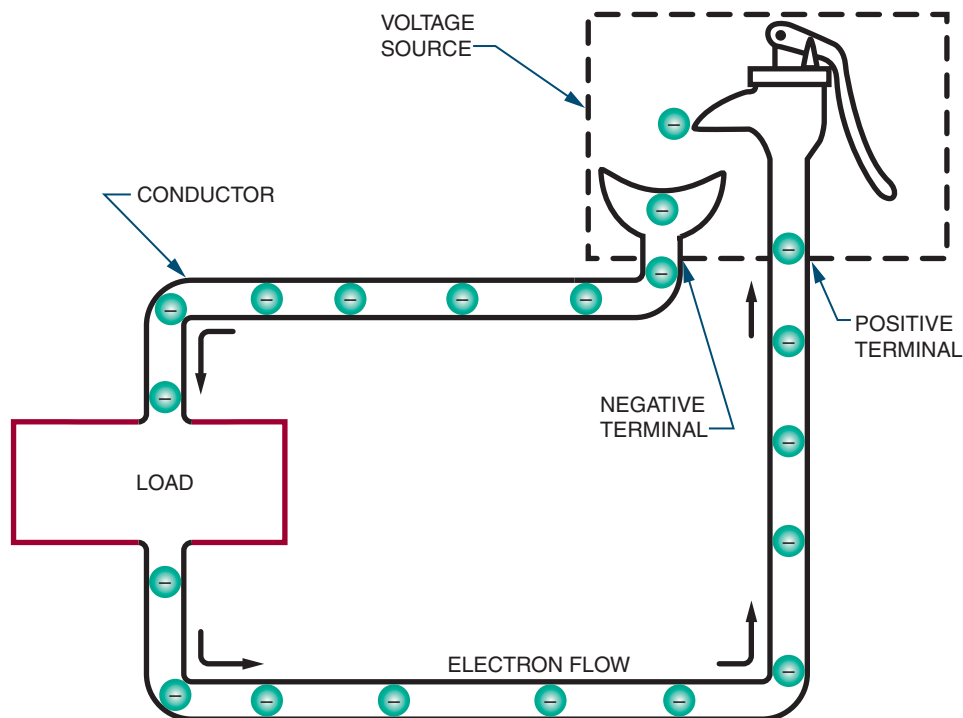
1. Define *electric current*.
2. What is the unit for measuring flow?
3. What is the relationship of current, coulombs, and time?
4. What is the current if 15 coulombs of charge flow past a point in a circuit in 5 seconds?
5. How long does it take for 3 coulombs to move past a point in a circuit if the circuit has 3 amperes of current flow?
6. What makes electrons move through a conductor in only one direction?

2-3 SCIENTIFIC NOTATION

In electronics, it is common to encounter very small and very large numbers. **Scientific notation** is a means of using single-digit numbers plus powers

FIGURE 2-5

A voltage source can be considered a pump that supplies electrons to the load and recycles the excess electrons.



of ten to express large and small numbers. For example, 300 in scientific notation is 3×10^2 .

The exponent indicates the number of decimal places to the right or left of the decimal point in the number. If the power is positive, the decimal point is moved to the right. For example:

$$3 \times 10^3 = 3.0 \times 10^3 = 3.000 = 3000$$

$\begin{array}{c} \uparrow \\ \text{3 places} \end{array}$

If the power is negative, the decimal point is moved to the left. For example:

$$3 \times 10^{-6} = 3.0 \times 10^{-6} = 0.000003 = 0.000003$$

$\begin{array}{c} \uparrow \\ \text{6 places} \end{array}$

Figure 2-6 lists some commonly used powers of ten, both positive and negative, and the prefixes and symbols associated with them. For example, an ampere (A) is a large unit of current that is not

FIGURE 2-6

Prefixes commonly used in electronics.

PREFIX	SYMBOL	VALUE	DECIMAL VALUE
Giga-	G	10^9	1,000,000,000
Mega-	M	10^6	1,000,000
Kilo-	k	10^3	1,000
Milli-	m	10^{-3}	0.001
Micro-	μ	10^{-6}	0.000001
Nano-	n	10^{-9}	0.000000001
Pico-	p	10^{-12}	0.000000000001

often found in low-power electronic circuits. More frequently used units are the **milliampere** (mA) and the **microampere** (μA). A milliampere is equal to

one-thousandth (1/1000) of an ampere or 0.001 A. In other words, it takes 1000 milliamperes to equal one ampere. A microampere is equal to one-millionth (1/1,000,000) of an ampere or 0.000001A; it takes 1,000,000 microamperes to equal one ampere.

EXAMPLE: How many milliamperes are there in 2 amperes?

Solution:

$$\frac{1000 \text{ mA}}{1 \text{ A}} = \frac{X \text{ mA}}{2 \text{ A}} \quad (1000 \text{ mA} = 1 \text{ A})$$

$$\frac{1000}{1} = \frac{X}{2}$$

$$(1)(X) = (1000)(2)$$

$$X = 2000 \text{ mA}$$

EXAMPLE: How many amperes are there in 50 micro-amperes?

Solution:

$$\frac{1,000,000 \mu\text{A}}{1 \text{ A}} = \frac{50 \mu\text{A}}{X \text{ A}}$$

$$\frac{1,000,000}{1} = \frac{50}{X}$$

$$(1)(50) = (1,000,000)(X)$$

$$\frac{50}{1,000,000} = X$$

$$0.00005 = X$$

$$0.00005 \text{ A} = X$$

2-3 QUESTIONS

1. Define *scientific notation*.
2. In scientific notation:
 - a. What does a positive exponent mean?
 - b. What does a negative exponent mean?
3. Convert the following numbers to scientific notation:
 - a. 500
 - b. 3768

c. 0.0056

d. 0.105

e. 356.78

4. Define the following prefixes:

a. Milli-

b. Micro-

5. Perform the following conversions:

a. 1.5 A = _____ mA

b. 1.5 A = _____ μA

c. 150 mA = _____ A

d. 750 μA = _____ A

SUMMARY

- Laws of electrostatic charges: like charges repel, unlike charges attract.
- Electrical charge (Q) is measured in coulombs (C).
- One coulomb is equal to 6.24×10^{18} electrons.
- An electric current is the slow drift of electrons from an area of negative charge to an area of positive charge.
- Current flow is measured in amperes.
- One ampere (A) is the amount of current that flows in a conductor when one coulomb of charge moves past a point in one second.
- The relationship between current, electrical charge, and time is represented by the formula:

$$I = \frac{Q}{t}$$

- Electrons (negative charge) represent the charge carrier in an electrical circuit.
- Hole movement (positive charge) occurs in the opposite direction to electron movement.
- Current flow in a circuit is from negative to positive.

- Electrons travel very slowly through a conductor, but individual electrons move at the speed of light.
- Scientific notation expresses a very large or small number as a numeral from 1 to 9 to a power of ten.
- If the power-of-ten exponent is positive, the decimal point is moved to the right.
- If the power-of-ten exponent is negative, the decimal point is moved to the left.
- The prefix *milli-* means one-thousandth.
- The prefix *micro-* means one-millionth.

CHAPTER 2 SELF-TEST

1. How much current is in a circuit if it takes 5 seconds for 7 coulombs to flow past a given point?
2. Describe how electrons flow in a circuit with reference to the potential in the circuit.
3. Convert the following numbers to scientific notation:
 - a. 235
 - b. 0.002376
 - c. 56323.786
4. What do the following prefixes represent?
 - a. Milli-
 - b. Micro-

Voltage

OBJECTIVES

After completing this chapter, the student will be able to:

- Identify the six most common voltage sources.
- Describe six different methods of producing electricity.
- Define a cell and a battery.
- Describe the difference between primary and secondary cells.
- Describe how cells and batteries are rated.
- Identify ways to connect cells or batteries to increase current or voltage output or both.
- Define *voltage rise* and *voltage drop*.
- Identify the two types of grounds associated with electrical circuits.



See accompanying CD for interactive presentations, tutorials and Voltage examples in MultiSim, Chapter 3.

In a piece of copper wire, the electrons are in random motion with no direction. To produce a current flow, the electrons must all move in the same direction. To produce motion in a given direction, energy must be imparted to the electrons in the copper wire. This energy comes from a source connected to the wire.

The force that causes the electrons to move in a common direction is referred to as *difference of potential*, or *voltage*. This chapter examines how voltage is produced.

3-1 VOLTAGE SOURCES

A current is produced when an electron is forced from its orbit around an atom. Any form of energy that dislodges electrons from atoms can be used to produce current. It is important to note that energy is not created; rather, there is simply a transfer of energy from one form to another. The source supplying the voltage is not simply a source of electrical energy. Instead, it is the means of converting some other form of energy

into electrical energy. The six most common voltage sources are friction, magnetism, chemicals, light, heat, and pressure.

Friction is the oldest known method of producing electricity. A glass rod can become charged when rubbed with a piece of fur or silk. This is similar to the charge you can generate by scuffing your feet across a carpet in a dry room. A **Van de Graaf generator** is a device that operates using the same principles as the glass rod and is capable of producing millions of volts (Figure 3-1).

Magnetism is the most common method of producing electrical energy today. If a wire is passed through a magnetic field, voltage is produced, as long as there is motion between the magnetic field and the conductor. A device based on this principle is called a **generator** (Figure 3-2). A generator can produce either direct current or alternating current, depending on how it is wired. When electrons flow in only one direction, the current is called **direct current (DC)**. When electrons flow in one direction then in the opposite direction, the current is called **alternating current (AC)**. A generator may be powered by steam from nuclear power or coal, water, wind, or gasoline or diesel engines. The schematic symbol for an AC generator is shown in Figure 3-3.

The second most common method of producing electrical energy today is by the use of a chemical **cell**. The cell consists of two dissimilar metals, copper and zinc, immersed in a salt, acid, or alkaline solution. The metals, copper and zinc, are the electrodes. The electrodes establish contact with the electrolyte (the salt, acid, or alkaline solution) and the circuit. The electrolyte pulls the free electrons from the copper electrode, leaving it with a positive charge. The zinc electrode attracts free electrons in the electrolyte and thus acquires a negative charge. Several of these cells can be connected together to form a battery. Figure 3-4 shows the schematic symbol for a cell and battery. Many types of cells and batteries are in use today (Figure 3-5).

FIGURE 3-1

A Van de Graaf generator is capable of producing millions of volts.



Light energy can be converted directly to electrical energy by light striking a photosensitive (light-sensitive) substance in a **photovoltaic cell (solar cell)** (Figure 3-6). A solar cell consists of photosensitive materials mounted between metal contacts. When the surface of the photosensitive material is exposed to light, it dislodges electrons from their orbits around the surface atoms of the material. This occurs because light has energy. A

FIGURE 3-2

A generator uses magnetism to produce electricity.

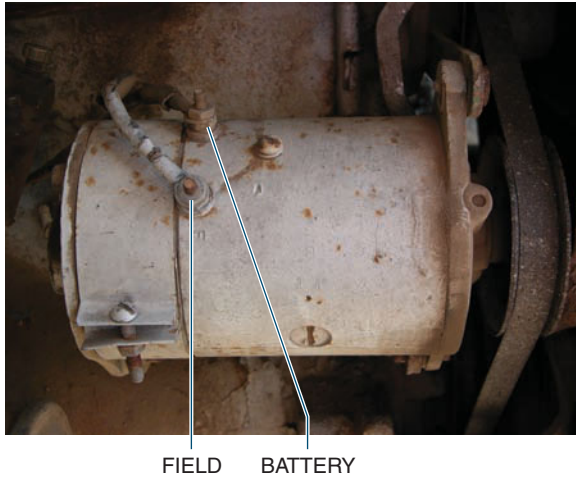


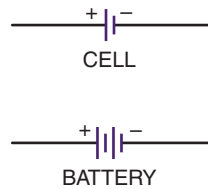
FIGURE 3-3

Schematic symbol for an alternating current generator.



FIGURE 3-4

Schematic symbol for a cell and a battery. The combination of two or more cells forms a battery.



single cell can produce a small voltage. Figure 3-7 shows the schematic symbol for a solar cell. Many cells must be linked together to produce a usable voltage and current. Solar cells are used primarily in satellites and cameras. The high cost of con-

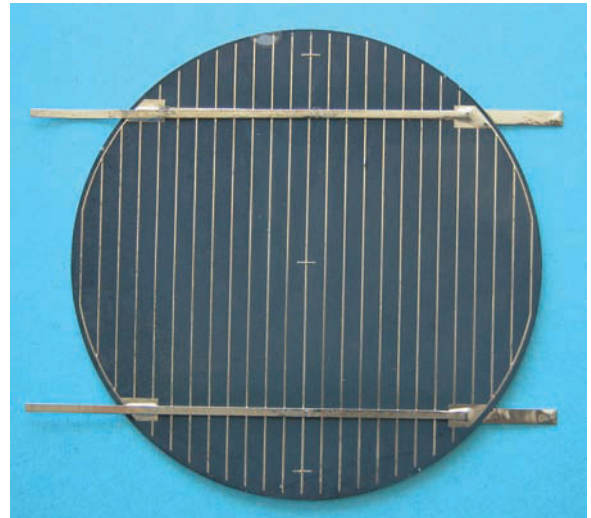
FIGURE 3-5

Some of the more common chemical batteries and cells in use today.



FIGURE 3-6

A photovoltaic cell can convert sunlight directly into electricity.



struction has limited their general application. However, the price of solar cells is declining.

Heat can be converted directly to electricity with a device called a **thermocouple** (Figure 3-8). The schematic symbol for a thermocouple is

FIGURE 3-7

Schematic symbol of a photovoltaic cell (solar cell).

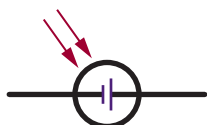


FIGURE 3-8

Thermocouples convert heat energy directly into electrical energy.

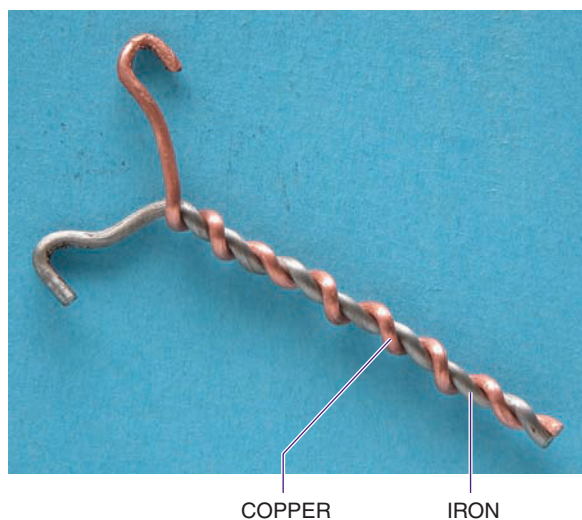


FIGURE 3-9

Schematic symbol for a thermocouple.



shown in Figure 3-9. A thermocouple consists of two dissimilar metal wires, twisted together. One wire is copper and the other wire is zinc or iron. When heat is applied to the twisted connection, the copper wire readily gives up free electrons, which are transferred to the other wire. Thus the copper wire develops a positive charge and the other wire develops a negative charge, and a small voltage occurs. The voltage is directly propor-

FIGURE 3-10

Crystal microphone.



FIGURE 3-11

Schematic diagram of piezoelectric crystal.



tional to the amount of heat applied. One application of the thermocouple is as a thermometer. Also called a pyrometer, these devices are often used in high-temperature kilns and foundries.

When pressure is applied to certain crystalline materials such as quartz, tourmaline, Rochelle salts, or barium titanate, a small voltage is produced. This is referred to as the **piezoelectric effect**. Initially, negative and positive charges are distributed randomly throughout a piece of crystalline material and no overall charge can be measured. However, when pressure is applied, electrons leave one side of the material and accumulate on the other side. A charge is produced as long as the pressure remains. When the pressure is removed, the charge is again distributed, so no overall charge exists. The voltage produced is small and must be amplified to be useful. Uses of the piezoelectric effect include crystal **microphones**, phonograph pickups (crystal cartridges), and precision oscillators (Figures 3-10, 3-11).

Note that while a voltage can be produced by these means, the reverse is also true; that is, a voltage can be used to produce magnetism, chemicals, light, heat, and pressure. Magnetism is evident in motors, speakers, solenoids, and relays. Chemical activities can be produced through electrolysis and electroplating. Light is produced with light bulbs and other optoelectric devices. Heat is produced with heating elements in stoves, irons, and soldering irons. And voltage can be applied to bend or twist a crystal.

3-1 QUESTIONS

1. What are the six most common voltage sources?
2. What is the most common method for producing a voltage?

3. What is the second most common method for producing a voltage?
4. Why are solar cells not used more for producing a voltage?

3-2 CELLS AND BATTERIES

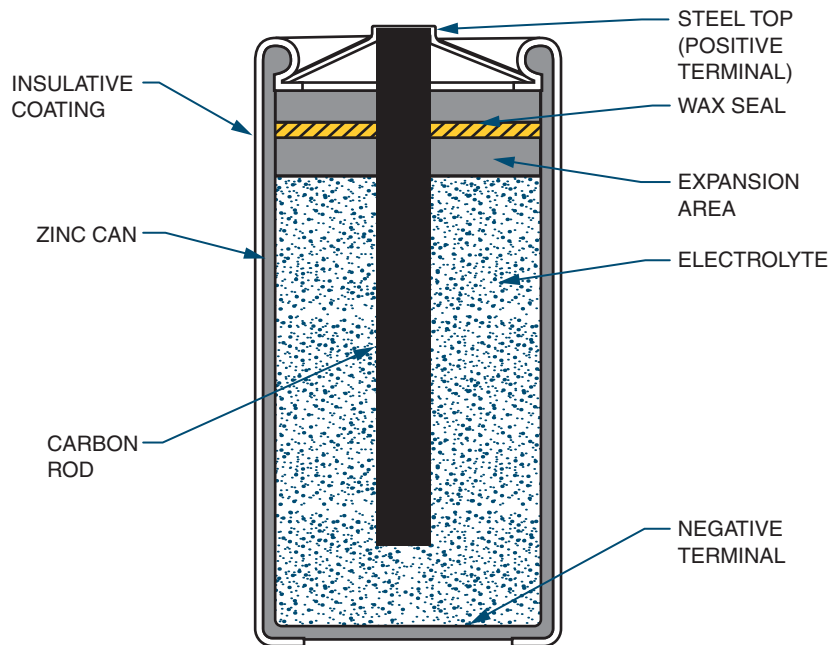
As mentioned in the previous unit, a cell contains a positive and a negative electrode separated by an electrolytic solution. A **battery** is a combination of two or more cells.

There are two basic types of cells. Cells that cannot be recharged are called **primary cells**. Cells that can be recharged are called **secondary cells**.

An example of a primary cell is a Leclanche cell, also called a dry cell (Figure 3-12). This type

FIGURE 3-12

Diagram of a dry cell (shown cut away).



of cell is not actually dry. It contains a moist paste as the electrolyte. A seal prevents the paste from leaking out when the cell is turned sideways or upside down. The electrolyte in a dry cell is a solution of ammonium chloride and manganese dioxide. The electrolyte dissolves the zinc electrode (the case of the cell) leaving an excess of electrons with the zinc. As the current is removed from the cell, the zinc, ammonium chloride, and manganese dioxide produce manganese dioxide, water, ammonia, and zinc chloride. The carbon rod (center electrode) gives up the extra electrons that accumulate on the zinc electrode. This type of cell produces as much as 1.75 to 1.8 volts when new. A typical Leclanche cell has an energy density of approximately 30 watt-hours per pound. As the cell is used, the chemical action decreases, and eventually the resulting current ceases. If the cell is not used, the electrolytic paste eventually dries out. The cell has a shelf life of about two years. The output voltage of this type of cell is determined entirely by the materials used for the electrolyte and the electrodes. The AA cell, C cell, D cell, and No. 6 dry cell (Figure 3–13) are all constructed of the same materials and therefore produce the same voltage. It should be noted that although the Leclanche cell is frequently referred to as a carbon-zinc (or zinc-carbon) cell, the carbon does not take any part in the chemical reaction that produces electricity.

The alkaline cell is named because of the highly caustic base, potassium hydroxide (KOH), used as the electrolyte. The design of an alkaline cell on the outside is very similar to that of a carbon-zinc cell. However, the inside of the alkaline cell is significantly different (Figure 3–14). Alkaline cells have an open-circuit rating of approximately 1.52 volts, and an energy density of about 45 watt-hours per pound. The alkaline cell performs much better over temperature extremes than carbon-zinc cells. Alkaline cells perform best where moderate-to-high currents are drawn over extended periods of time.

FIGURE 3–13

Some common examples of dry cells.

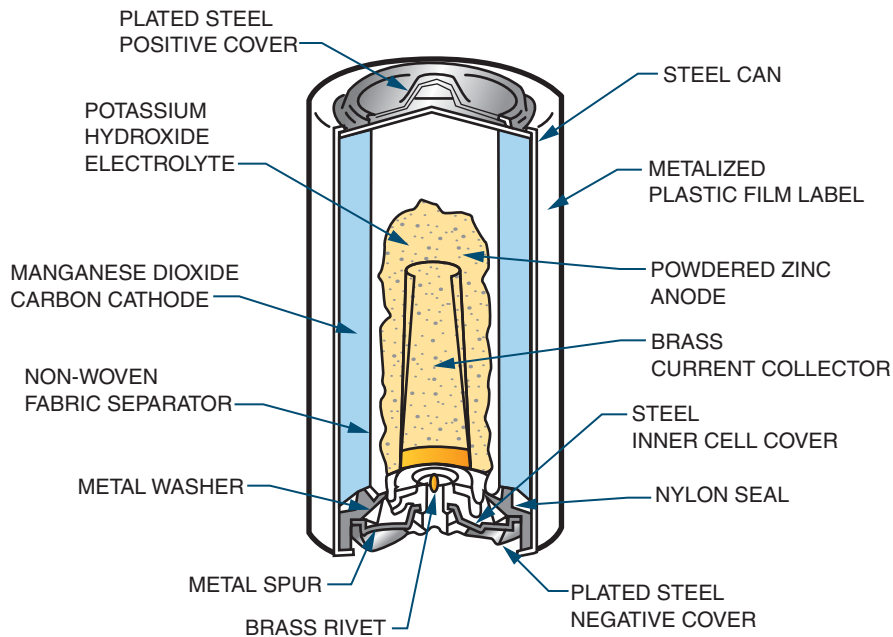


Lithium cells (Figure 3–15) have overcome the inherent properties associated with lithium. Lithium is extremely reactive with water. Lithium cell formation uses lithium, manganese dioxide (MnO_2), and a lithium perchlorate (LiClO_4) in an organic solvent (water cannot be used). The output of a lithium cell is approximately 3 volts. Lithium cells are very efficient, with energy densities of about 90 watt-hours per pound. The greatest benefit of lithium cells is their extremely long shelf life of five to ten years.

A secondary cell is a cell that can be recharged by applying a reverse voltage. An example is the lead-acid battery used in automobiles (Figure 3–16). It is made of six 2-volt secondary cells connected in series. Each cell has a positive electrode of lead peroxide (PbO_2) and a negative electrode of spongy lead (Pb). The electrodes are separated by plastic or rubber and immersed in

FIGURE 3-14

Alkaline cells are constructed inside out. The cathode surrounds the anode.



an electrolytic solution of sulfuric acid (H_2SO_4) and distilled water (H_2O). As the cell is discharged, the sulfuric acid combines with the lead sulfate, and the electrolyte converts to water. Recharging the cell involves applying a source of DC voltage greater than that produced by the cell. As the current flows through the cell, it changes the electrode back to lead peroxide and spongy lead and converts the electrolyte back to sulfuric acid and water. This type of cell is also referred to as a wet cell.

Another type of secondary cell is the nickel-cadmium (Ni-Cad) cell (Figure 3-17). This is a dry cell that can be recharged many times and can hold its charge for long periods of time. It consists of a positive and negative electrode, a separator, electrolyte, and package. The electrodes consist of a deposit of powdered nickel on a nickel wire screen, which is coated with a nickel salt solution

for the positive electrode and a cadmium salt solution for a negative electrode. The separator is made of an absorbent insulating material. The electrolyte is potassium hydroxide. A steel can forms the package and is sealed tightly. A typical voltage from this type of cell is 1.2 volts.

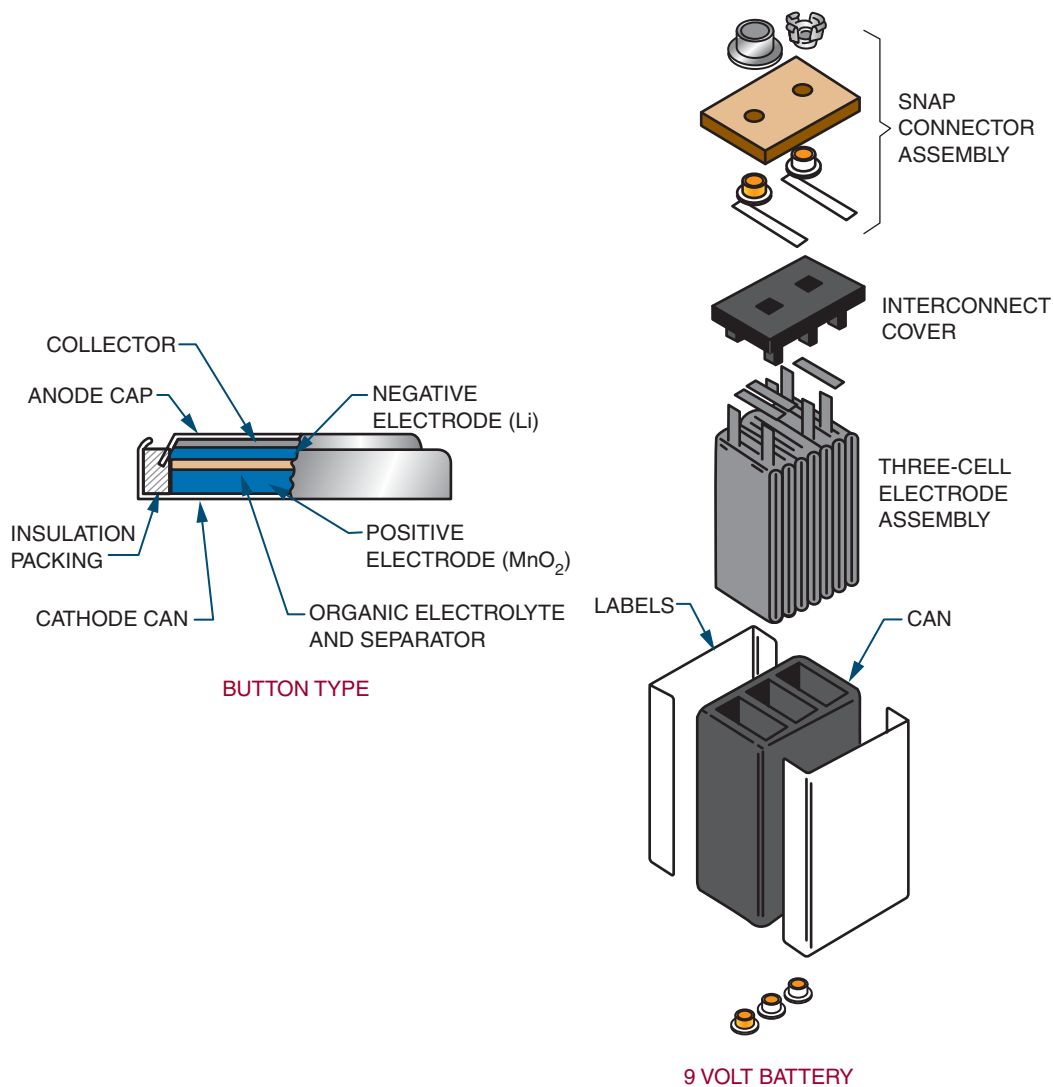
The ability of a battery to deliver power continuously is expressed in **ampere-hours**. A battery rated at 100 ampere-hours can continuously supply any of the following: 100 amperes for 1 hour ($100 \times 1 = 100$ ampere-hours), 10 amperes for 10 hours ($10 \times 10 = 100$ ampere-hours), or 1 ampere for 100 hours ($1 \times 100 = 100$ ampere-hours).

3-2 QUESTIONS

1. What are the components of a cell?
2. What are the two basic types of cells?

FIGURE 3-15

Lithium cells have extremely high energy density.



3. What is the major difference between the two types of cells?
4. List some examples of a primary cell.
5. List some examples of a secondary cell.

3-3 CONNECTING CELLS AND BATTERIES

Cells and batteries can be connected together to increase voltage and/or current. They can be connected in series, in parallel, or in series-parallel.

FIGURE 3-16

An example of a secondary cell (shown cut away).

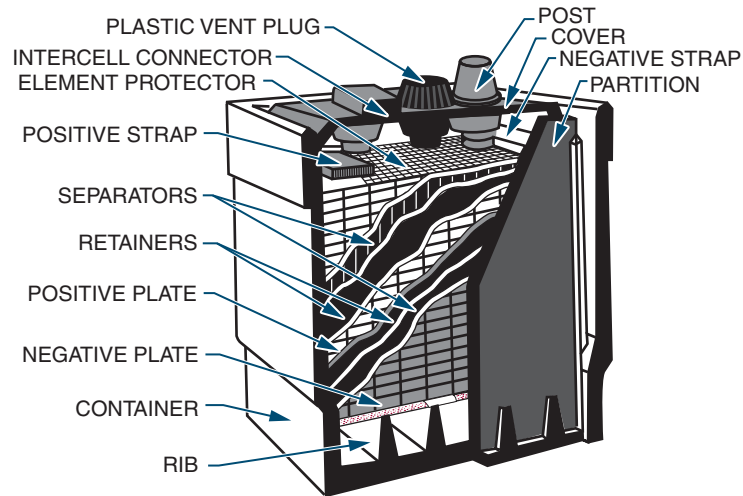


FIGURE 3-17

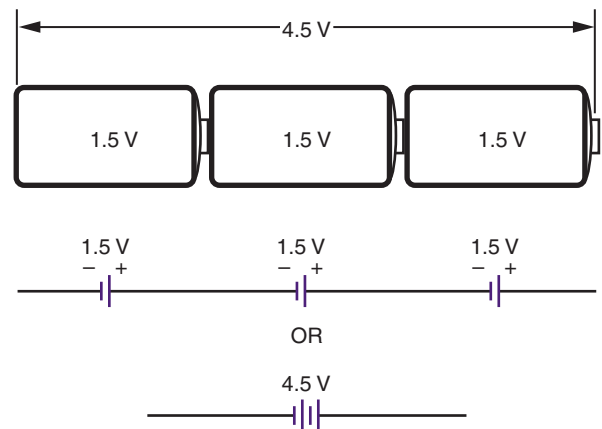
A nickel-cadmium (Ni-Cd) battery is another example of a secondary cell.



In series, cells or batteries can be connected in either series-aiding or series-opposing configurations. In a **series-aiding** configuration, the positive terminal of the first cell is connected to the negative terminal of the second cell; the positive terminal of the second cell is connected to the

FIGURE 3-18

Cells or batteries can be connected in series to increase voltage.



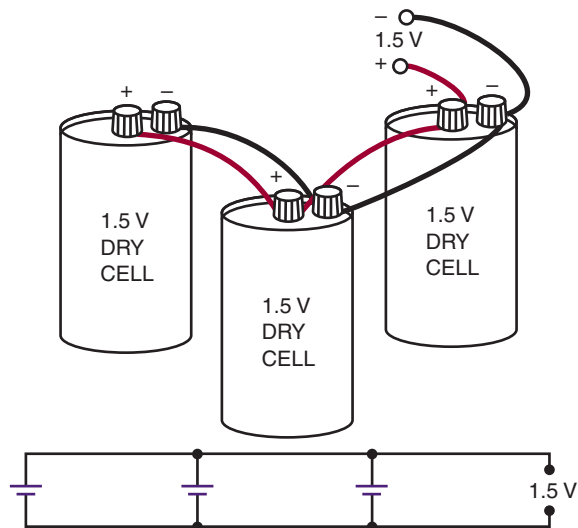
negative terminal of the third cell, and so on (Figure 3-18). In a series-aiding configuration the same current flows through all the cells or batteries. This can be expressed as:

$$I_T = I_1 = I_2 = I_3$$

The subscript numbers refer to the number of each individual cell or battery. The total voltage is

FIGURE 3-19

Cells or batteries can be connected in parallel to increase current flow.



the sum of the individual cell voltages and can be expressed as:

$$E_T = E_1 + E_2 + E_3$$

In a **series-opposing** configuration, the cells or batteries are connected with like terminals together, negative to negative or positive to positive. However, this configuration has little practical application.

In a **parallel** configuration, all the positive terminals are connected together and all the negative terminals are connected together (Figure 3-19). The total current available is the sum of the individual currents of each cell or battery. This can be expressed as:

$$I_T = I_1 + I_2 + I_3$$

The total voltage is the same as the voltage of each individual cell or battery. This can be expressed as:

$$E_T = E_1 = E_2 = E_3$$

If both a higher voltage and a higher current are desired, the cells or batteries can be connected

FIGURE 3-20

Cells and batteries can be connected in series-parallel to increase current and voltage outputs.

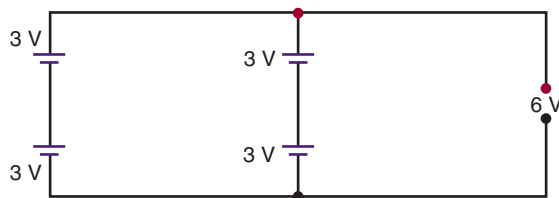
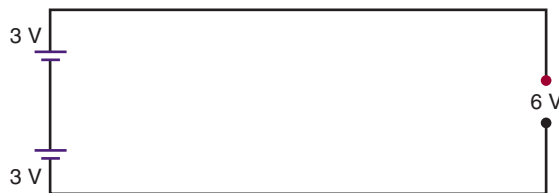


FIGURE 3-21

The voltage increases when cells are connected in series.



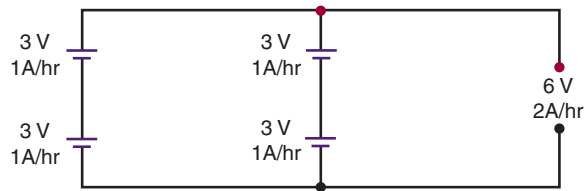
in a series-parallel configuration. Remember, connecting cells or batteries in series increases the voltage, and connecting cells or batteries in parallel increases the current. Figure 3-20 shows four 3-volt batteries connected in a series-parallel configuration. This configuration produces a total voltage of 6 volts with a current twice that of an individual battery. It is necessary to connect the two 3-volt batteries in series to get the 6 volts (Figure 3-21). To increase the current, a second pair of 3-volt batteries is connected in series, and the resulting series-connected batteries are connected in parallel (Figure 3-22). The overall result is a **series-parallel** configuration.

3-3 QUESTIONS

1. Draw three cells connected in a series-aiding configuration.
2. What effect does a series-aiding configuration have on current and voltage?

FIGURE 3–22

Connecting the series-connected cells in parallel increases the output current. The net result is a series-parallel configuration.



3. Draw three cells connected in parallel.
4. What effect does connecting cells in parallel have on current and voltage?
5. How can cells or batteries be connected to increase both current and voltage?

3–4 VOLTAGE RISES AND VOLTAGE DROPS

In electric and electronic circuits, there are two types of voltage: voltage rise and voltage drop.

Potential energy, or voltage, introduced into a circuit is called a **voltage rise** (Figure 3–23). The voltage is connected to the circuit so that the current flows from the negative terminal of the voltage source and returns to the positive terminal of

FIGURE 3–23

A potential applied to a circuit is called a voltage rise.

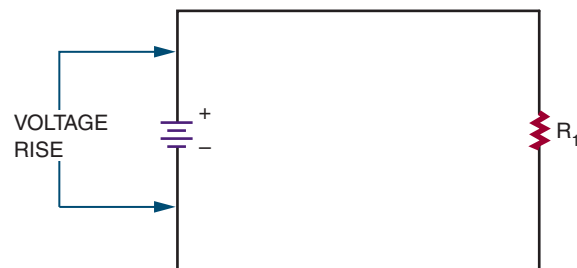
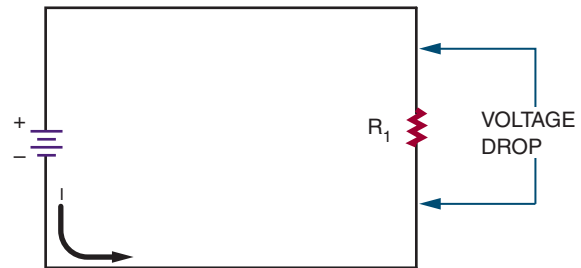


FIGURE 3–24

The energy used by the circuit in passing current through the load (resistance) is called a voltage drop. A voltage drop occurs when current flows in the circuit.



the voltage source. A 12-volt battery connected to a circuit gives a voltage rise of 12 volts to the circuit.

As the electrons flow through the circuit, they encounter a load, some resistance to the flow of electrons. As electrons flow through the load, they give up their energy. The energy given up is called a **voltage drop** (Figure 3–24). The energy is given up in most cases as heat. The energy that the electrons give up to a circuit is the energy given to them by the source.

To repeat, energy introduced into a circuit is called a voltage rise. Energy used up in a circuit by the load is called a voltage drop. A voltage drop occurs when there is a current flow in the circuit. Current moves through a circuit from the negative polarity to the positive polarity. The voltage source establishes the voltage rise from the negative terminal to the positive terminal.

The voltage drop in a circuit equals the voltage rise of the circuit, because energy cannot be created or destroyed, only changed to another form. If a 12-volt source is connected to a 12-volt lamp, the source supplies a 12-volt voltage rise, and the lamp produces a 12-volt voltage drop. All the energy is consumed in the circuit. If two identical 6-volt lamps are connected in series to the same 12-volt source (Figure 3–25), each lamp produces a 6-volt drop, for a total of 12 volts. If

FIGURE 3-25

Two identical 6-volt lamps each produce a 6-volt drop when connected in series to a 12-volt source.

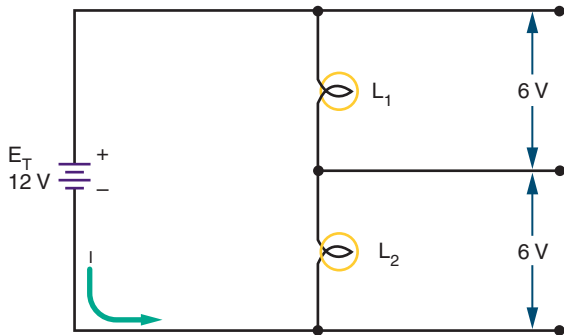
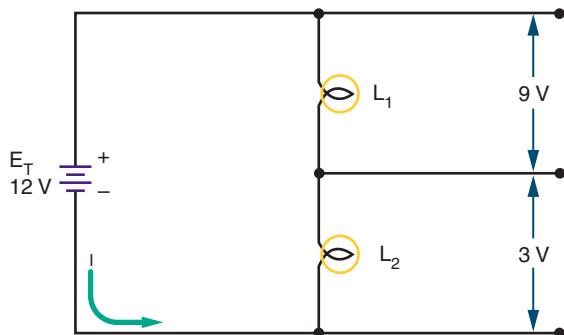


FIGURE 3-26

When two lamps of different voltage are connected in series to a 12-volt source, the voltage drop across each lamp will differ, based on the voltage requirement of the lamp.



two different lamps are connected in series, such as a 9-volt lamp and a 3-volt lamp (Figure 3-26), the 9-volt lamp produces a voltage drop of 9 volts, and the 3-volt lamp produces a voltage drop of 3 volts. The sum of the voltage drops equals the voltage rise of 12 volts.

3-4 QUESTIONS

1. What is a voltage rise?
2. What is a voltage drop?

3. If two identical resistors are connected in series to a voltage source, what is the voltage drop across each of the resistors?

3-5 GROUND AS A VOLTAGE REFERENCE LEVEL

Ground is a term used to identify zero potential. All other potentials are either positive or negative with respect to ground. There are two types of grounds: earth and electrical.

In the home, all electrical circuits and appliances are earth grounded. Consequently, no difference of potential exists between any two appliances or circuits. All circuits are tied to a common point in the circuit panel box (circuit-breaker or fuse box) (Figure 3-27). This common point (the neutral bus) is then connected by a heavy copper wire to a copper rod driven into the earth or fastened to the metal pipe that supplies water to the home. This protects the user from electrical shock in case of a faulty connection.

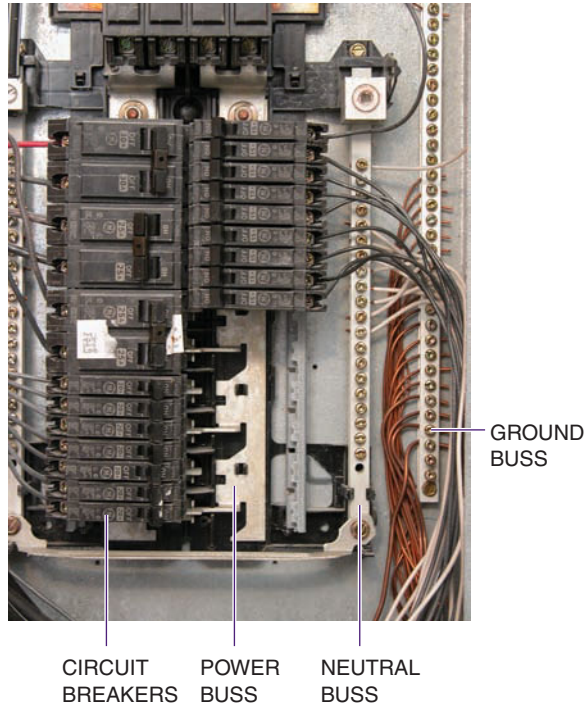
Electrical grounding is used in automobiles. Here the chassis of the automobile is used as a ground. This can be verified by seeing where the battery cables are attached to the automobile. Generally, the negative terminal is bolted directly to the frame of the automobile. This point or any other point on the frame of the automobile is considered to be ground. Ground serves as part of the complete circuit.

In electronics, electrical ground serves a different purpose: *Ground* is defined as the zero reference point against which all voltages are measured. Therefore, the voltage at any point in a circuit may be measured with reference to ground. The voltage measured may be positive or negative with respect to ground.

In larger pieces of electronic equipment, the chassis or metal frame serves as the ground point

FIGURE 3–27

In a residential circuit panel box, all circuits are tied to a common point (the neutral bus).



(reference point), as in the automobile. In smaller electronic devices plastic is used for the chassis, and all components are connected to a printed circuit board. In this case, ground is a copper pad on the circuit board that acts as a common point to the circuit.

3–5 QUESTIONS

1. What are the two types of grounds?
2. What is the purpose of earth grounding?
3. How is an electrical ground used in an automobile?
4. How is an electrical ground used in a piece of electronic equipment?

5. In electronics, what function does ground serve when taking voltage measurements?

SUMMARY

- Current is produced when an electron is forced from its orbit.
- Voltage provides the energy to dislodge electrons from their orbit.
- A voltage source provides a means of converting some other form of energy into electrical energy.
- Six common voltage sources are: friction, magnetism, chemicals, light, heat, and pressure.
- Voltage can be used to produce magnetism, chemicals, light, heat, and pressure.
- Magnetism is the most common method used to produce a voltage.
- Chemical cells are the second most common means of producing a voltage.
- A cell contains positive and negative electrodes separated by an electrolytic solution.
- A battery is a combination of two or more cells.
- Cells that cannot be recharged are called primary cells.
- Cells that can be recharged are called secondary cells.
- Dry cells are primary cells.
- Lead-acid batteries and nickel-cadmium (Ni-Cad) cells are examples of secondary cells.
- Cells and batteries can be connected in series, in parallel, or in series-parallel to increase voltage, current, or both.
- When cells or batteries are connected in a series-aiding configuration, the output current remains the same, but the output voltage increases.

$$I_T = I_1 = I_2 = I_3 \quad E_T = E_1 + E_2 + E_3$$

- When cells or batteries are connected in parallel, the voltage output remains the same but the output current available increases.

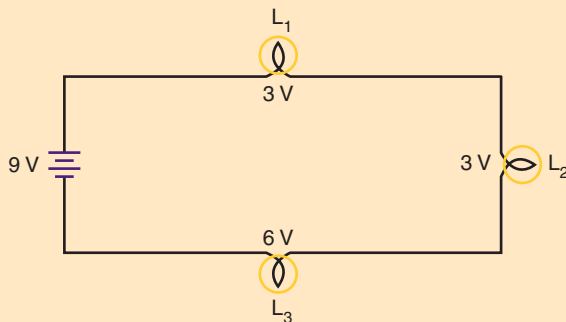
$$I_T = I_1 + I_2 + I_3 \quad E_T = E_1 = E_2 = E_3$$

- A series-parallel combination increases both the output voltage and the output current.
- Voltage applied to a circuit is referred to as a voltage rise.

- The energy used by a circuit is referred to as a voltage drop.
- The voltage drop in a circuit equals the voltage rise.
- Two types of ground are earth and electrical.
- Earth grounding is used to prevent electric shock by keeping all appliances and equipment at the same potential.
- Electrical grounding provides a common reference point.

CHAPTER 3 SELF-TEST

1. Does current or voltage actually perform the work in a circuit?
2. List six forms of energy that can be used to produce electricity.
3. How are secondary cells rated?
4. Draw a series-parallel combination that will supply 9 volts at 1 ampere. Use 1½-volt cells rated at 250 milliamperes.
5. What is the voltage drop across three lamps of 3 volts, 3 volts, and 6 volts with 9 volts applied?



Resistance

OBJECTIVES

After completing this chapter, the student will be able to:

- Define resistance and explain its affect in a circuit.
- Determine the tolerance range of a resistor.
- Identify carbon composition, wirewound, and film resistors.
- Identify potentiometers and rheostats.
- Describe how a variable resistor operates.
- Decode a resistor's value using the color code or alphanumeric code.
- Identify the three types of resistor circuits.
- Calculate total resistance in series, parallel, and series-parallel circuits.



See accompanying CD for interactive presentations, tutorials and Resistance examples in MultiSim, Chapter 4.

Resistance is opposition to the flow of current. Some materials such as glass and rubber offer great opposition to current flow. Other materials such as silver and copper offer little opposition to current flow. This chapter examines the characteristics of resistance, types of resistance, and the effects of connecting resistors together by a conductor to form a circuit.

4-1 RESISTANCE

As previously mentioned, every material offers some resistance or opposition to the flow of current. Some conductors such as silver, copper, and

aluminum offer very little resistance to current flow. Insulators such as glass, wood, and paper offer high resistance to current flow.

The size and type of wires in an electric circuit are chosen to keep the electrical resistance as low as possible. This allows the current to flow easily through the conductor. In an electric circuit, the larger the diameter of the wire, the lower the electrical resistance to current flow.

Temperature also affects the resistance of an electrical conductor. In most conductors (copper, aluminum, and so on), resistance increases with temperature. Carbon is an exception because the resistance decreases as temperature increases. Certain alloys of metals (manganin and constantan)

FIGURE 4-1

Resistance of several conductors of the same length and cross-section area.

CONDUCTOR MATERIAL	RESISTIVITY
Silver	1.000
Copper	1.0625
Lead	1.3750
Gold	1.5000
Aluminum	1.6875
Iron	6.2500
Platinum	6.2500

have resistance that does not change with temperature.

The relative resistance of several conductors of the same length and cross section is shown in Figure 4-1. Silver is used as a standard of 1 and the remaining metals are arranged in order of ascending resistance.

The resistance of an electric circuit is expressed by the symbol R . Manufactured circuit parts containing definite amounts of resistance are called resistors. Resistance (R) is measured in ohms. One ohm is the resistance of a circuit or circuit element that permits a steady current flow of one ampere (one coulomb per second) when one volt is applied to the circuit.

4-1 QUESTIONS

1. What is the difference between conductors and insulators?
2. How does the diameter of a piece of wire affect its resistance?
3. What factors affect the resistance of a conductor?
4. What material makes the best conductor?

4-2 CONDUCTANCE

The term in electricity that is opposite of resistance is **conductance** (G). Conductance is the ability of a material to pass electrons. The unit of conductance is **Mho**, ohm spelled backwards. The symbol used to represent conductance is the inverted Greek letter omega (Ω). Conductance is the reciprocal of resistance and is measured in **Siemens** (S). A reciprocal is obtained by dividing the number into one.

$$R = 1/G$$

$$G = 1/R$$

If the resistance of a material is known, dividing its value into one will give its conductance. Similarly, if the conductance is known, dividing its value into one will give its resistance.

4-2 QUESTIONS

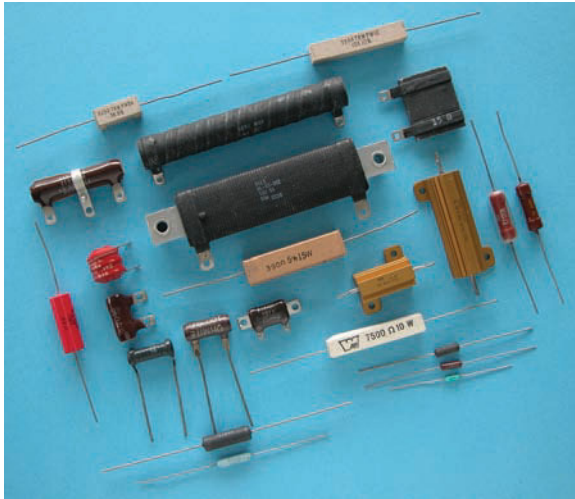
1. Define the term *conductance*.
2. What is the significance of conductance in a circuit?
3. What symbol is used to represent conductance?
4. What is the unit of conductance?

4-3 RESISTORS

Resistance is a property of all electrical components. Sometimes the effect of resistance is undesirable, other times it is constructive. **Resistors** are components manufactured to possess a specific value of resistance to the flow of current. A resistor is the most commonly used component in an electronic circuit. Resistors are available with fixed or variable resistance values. They are available in a variety of shapes and sizes to meet specific circuit, space, and operating requirements (Figures 4-2 and 4-3). Resistors are drawn

FIGURE 4-2

Fixed resistors come in various sizes and shapes.



schematically as a series of jagged lines, as shown in Figure 4-4.

A resistor's **tolerance** is the amount that the resistor may vary and still be acceptable. It is expensive for a manufacturer to hold a resistor to a certain value when an exact value is not needed. Therefore, the larger the tolerance, the cheaper it is to manufacture. Resistors are available with tolerances of $\pm 20\%$, $\pm 10\%$, $\pm 5\%$, $\pm 2\%$, and $\pm 1\%$. Precision resistors are available with even smaller tolerances. In most electronic circuits, resistors of 10% tolerance are satisfactory.

EXAMPLE: How much can a 1000-ohm resistor with a 20% tolerance vary and still be acceptable?

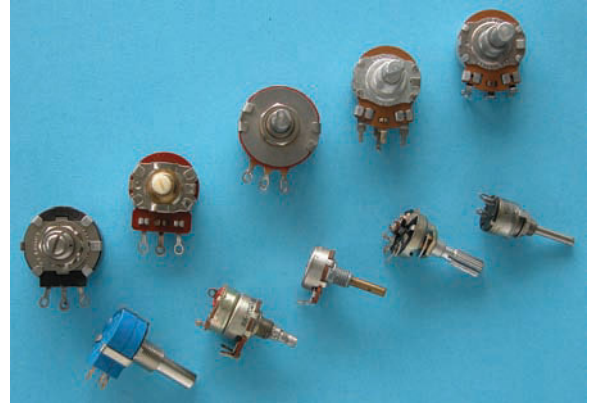
Solution: $1000 \times 0.20 = \pm 200$ ohms

$$\begin{array}{r} \text{or} \\ 1000 \\ \times 0.20 \\ \hline 200.00 \text{ ohms} \end{array}$$

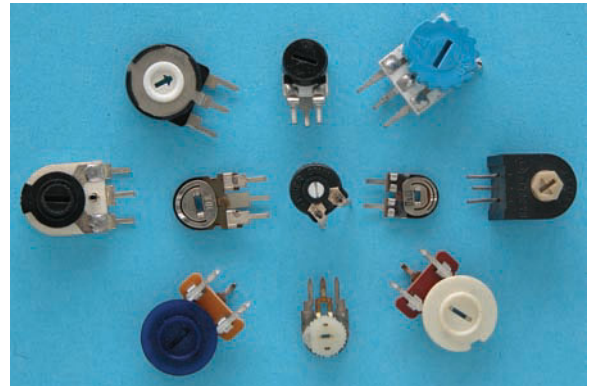
The tolerance is ± 200 ohms. Therefore, the 1000-ohm resistor may vary from 800 to 1200 ohms and still be satisfactory.

FIGURE 4-3

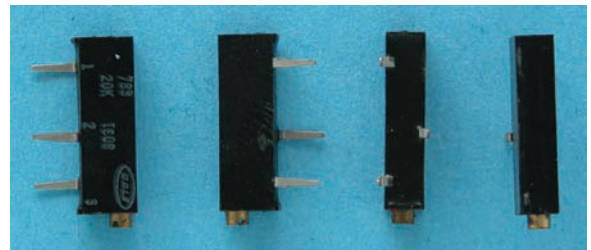
Variable resistors come in many styles to meet the needs of manufacturers of electronic equipment.



HOT MOLDED POTENTIOMETERS



TRIMMING POTENTIOMETERS



TRIM POTENTIOMETER

FIGURE 4-4

Schematic diagram of a fixed resistor.



FIGURE 4-5

Standard resistor values (exclusive of multiplier band).

$\pm 1\%$ TOLERANCE	$\pm 5\%$ TOLERANCE	$\pm 10\%$ TOLERANCE	$\pm 20\%$ TOLERANCE
1.0		1.0	1.0
1.1			
1.2		1.2	
1.3			
1.5		1.5	1.5
1.6			
1.8		1.8	
2.0			
2.2		2.2	2.2
2.4			
2.7		2.7	
3.0			
3.3		3.3	3.3
3.6			
3.9		3.9	
4.3			
4.7		4.7	4.7
5.1			
5.6		5.6	
6.2			
6.8		6.8	6.8
7.5			
8.2		8.2	
9.1			

For the sake of uniformity, electronic manufacturers offer a number of standard resistor values. Figure 4-5 is a list of standard values for resistors with $\pm 5\%$, $\pm 10\%$, and $\pm 20\%$ tolerance. After the value on the chart is obtained, it is mul-

FIGURE 4-6

Carbon composition resistors are the most widely used resistors in electronic circuits.

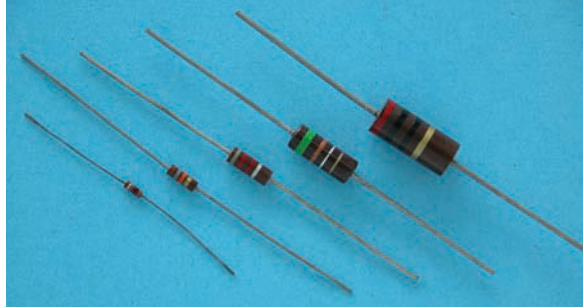
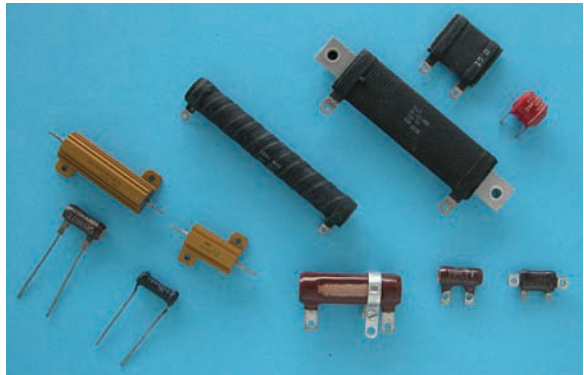


FIGURE 4-7

Wirewound resistors are available in many different styles.



tiplied by the value associated with the color of the multiplier band.

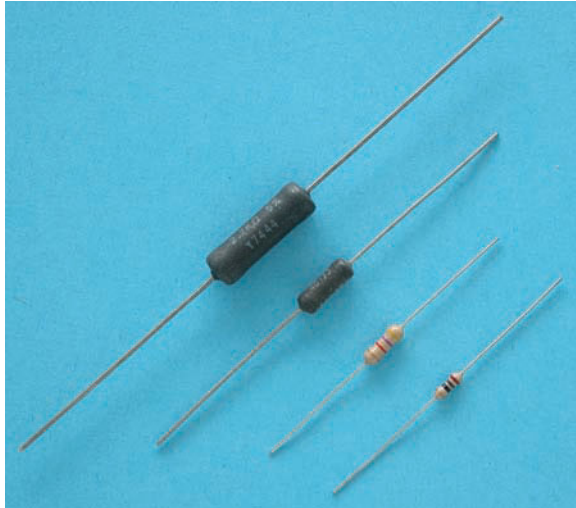
Resistors fall into three major categories, named for the material they are made of: molded carbon composition resistors, wirewound resistors, and film resistors.

Until recently, the *molded carbon composition* resistor was the most commonly used resistor in electronic circuits (Figure 4-6). It is manufactured in standard resistor values.

The *wirewound* resistor is constructed of a nickel-chromium alloy (nichrome) wire wound on a ceramic form (Figure 4-7). Leads are at-

FIGURE 4–8

The film resistor offers the size of the carbon resistor with the accuracy of the wirewound resistor.

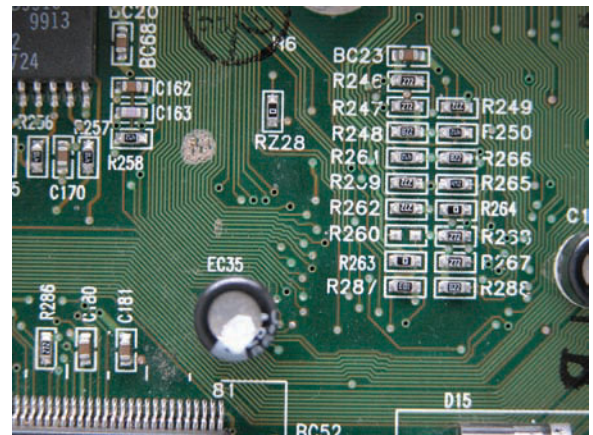
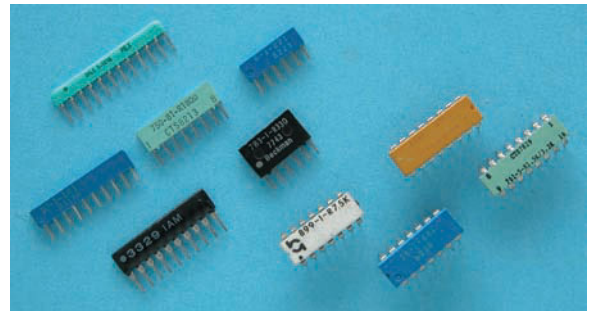


tached and the entire resistor sealed with a coating. Wirewound resistors are used in high-current circuits where precision is necessary. The resistance range varies from a fraction of an ohm to several thousand ohms.

Film resistors have become popular (Figure 4–8) because they offer the small size of the composition resistor with the accuracy of the wirewound resistor. A thin film of carbon or metal alloy is deposited on a cylindrical ceramic core and sealed in an epoxy or glass coating. The value of the resistor is set by cutting a spiral groove through the film, the length of the resistor. The closer the pitch of the spiral, the higher the resistance. Carbon film resistors are available from 10 ohms to 2.5 megohms at a $\pm 1\%$ tolerance. Metal film resistors are physically similar to carbon film resistors but are less expensive. They are available from 10 ohms to 1.5 megohms at a $\pm 1\%$ tolerance, although tolerances down to $\pm 0.1\%$ are avail-

FIGURE 4–9

Tin oxide resistors.



able. Another type of film resistor is the tin oxide resistor (Figure 4–9). It consists of a tin oxide film on a ceramic substrate.

Surface-mount resistors are ideal for small circuit applications. A thin film of carbon or metal alloy is deposited on a ceramic base or substrate. Contact from the resistive element to the printed circuit board is via metal end caps or terminals, resulting in zero lead length. In application, these end caps are soldered directly to the circuit board conductive trace using an automated soldering process. The lack of long leads to solder into the printed circuit board yields several advantages. Among them are lightweight, smaller printed circuit board sizes

FIGURE 4-10

Variable resistors allow the resistance to increase or decrease at random.

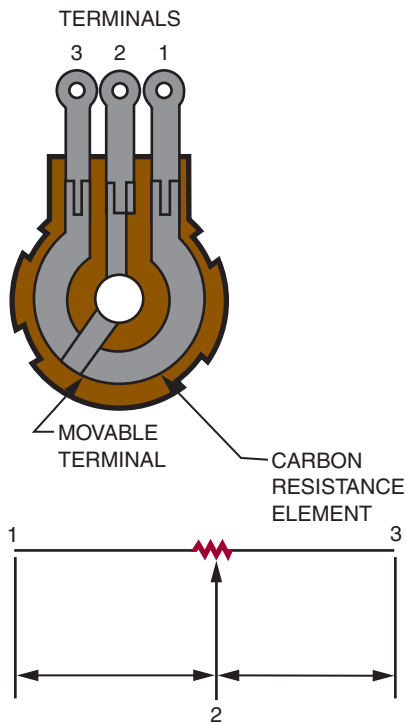
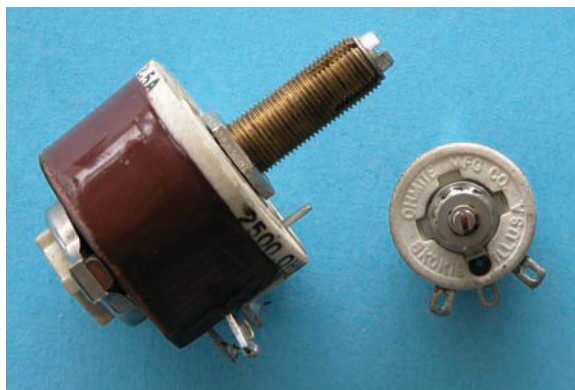


FIGURE 4-11

A rheostat is a variable resistor used to control current.



and the use of automated assembly processes. Surface-mount resistors are available in both thick and thin films. They are available from zero ohms to 10 megohms at tolerance of $\pm 5\%$ down to $\pm 0.1\%$ with power-handling capabilities of $\frac{1}{16}$ watt to 1 watt.

Variable resistors allow the resistance to vary. They have a resistive element of either carbon composition or wire that is connected to two terminals. A third terminal is attached to a movable wiper, which is connected to a shaft. The wiper slides along the resistive element when the shaft is rotated. As the shaft is rotated, the resistance between the center terminal and one outer terminal increases while the resistance between the center terminal and the other outer terminal decreases (Figure 4-10). Variable resistors are available with resistance that varies linearly (a linear taper) or logarithmically (an audio taper).

A variable resistor used to control voltage is called a **potentiometer** or *pot*. A variable resistor used to control current is called a **rheostat** (Figure 4-11).

4-3 QUESTIONS

1. What is the purpose of specifying the tolerance of a resistor?
2. What are the three major types of fixed resistors?
3. What is the advantage of film resistors over carbon composition resistors?
4. Explain how a variable resistor works.

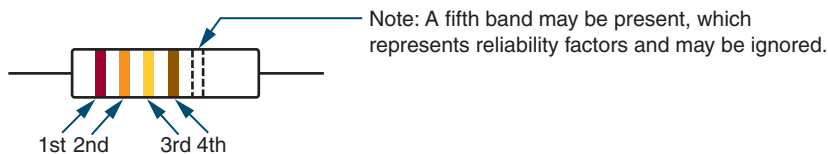
4-4 RESISTOR IDENTIFICATION

The small size of the resistor prevents printing the resistance value and tolerance on its case. Therefore, a color-coded strip system is used to display the resistor value. The strips can be seen and read in any position that the resistor is placed. The Electronic Industries Association (EIA) color code is shown in Figure 4-12.

FIGURE 4-12

The Electronic Industries Association (EIA) color code.

Two-Significant-Figure Color Code



	1ST BAND 1ST DIGIT	2ND BAND 2ND DIGIT	3RD BAND NUMBER OF ZEROS	4TH BAND TOLERANCE
Black	0	0	—	—
Brown	1	1	0	1%
Red	2	2	00	2%
Orange	3	3	000	—
Yellow	4	4	0,000	—
Green	5	5	00,000	0.5%
Blue	6	6	000,000	0.25%
Violet	7	7		0.10%
Gray	8	8		0.05%
White	9	9		—
Gold			×0.1	5%
Silver			×0.01	10%
No Color				20%

FIGURE 4-13

Meaning of the colored bands on a carbon composition resistor.

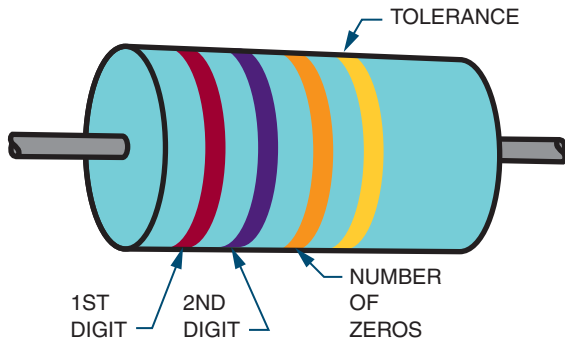
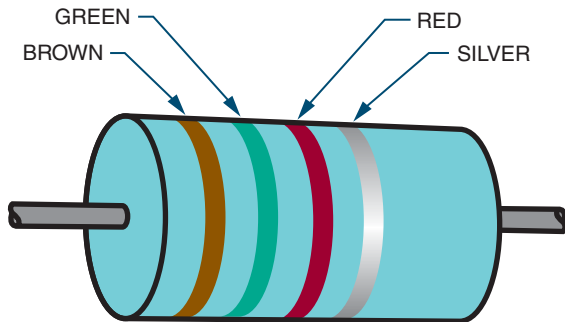


FIGURE 4-14

This resistor has a resistance value of 1500 ohms.

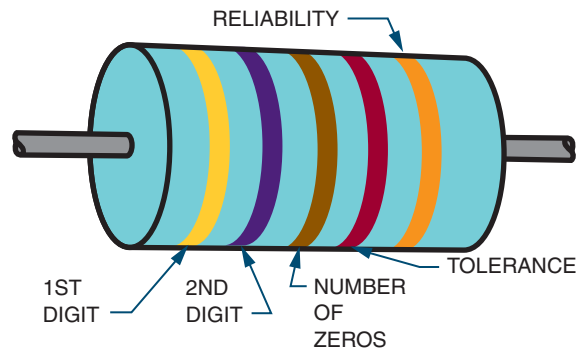


The meaning of the colored bands on a resistor is as follows. The first band, closest to the end of the resistor, represents the first digit of the resistor value. The second band represents the second digit of the resistor value. The third band represents the number of zeros to be added to the first two digits. The fourth band represents the tolerance of the resistor (Figure 4-13).

For example, the resistor shown in Figure 4-14 has a resistance value of 1500 ohms. The brown band (first band) represents the first digit (1). The green band (second band) represents the second digit (5). The red band (third band) represents the number of zeros (two zeros—00) to be

FIGURE 4-15

The fifth band on a resistor indicates the resistor's reliability.



added to the first two digits. The silver band (fourth band) indicates a resistance tolerance of $\pm 10\%$. Therefore, this is a 1500-ohm resistor with a $\pm 10\%$ tolerance.

A resistor may have a fifth band (Figure 4-15). This band indicates the reliability of the resistor. It tells how many of the resistors (per thousand) will fail after 100 hours of operation. Generally, when there are five bands on a resistor, the same amount of body color shows at each end. In this case, look for the tolerance band (gold or silver), position it on the right, and read the resistor as described previously.

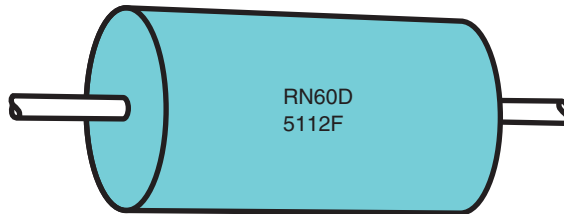
There are two instances where the third band does not mean the number of zeros. For resistor values of less than 10 ohms, the third band is gold. This means that the first two digits should be multiplied by 0.1. For resistor values of less than 1 ohm, the third band is silver. This means the first two digits are multiplied by 0.01.

A resistor may also be identified by a letter-and-number (alphanumeric) system (Figure 4-16). For example, RN60D5112F has the following meaning:

RN60	Resistor style (composition, wirewound, film)
D	Characteristic (effects of temperature)
5112	Resistance value (2 represents number of zeros)
F	Tolerance

FIGURE 4-16

Resistors may also be identified by a letter-and-number system.



The resistor value is the primary concern. The value of the resistor may be indicated by three to five digits. In all cases, the last digit indicates the number of zeros to be added to the preceding digits. In the example given, the last digit (2) indicates the number of zeros to be added to the first three digits (511). So 5112 translates to 51,100 ohms.

In some cases an *R* may be inserted into the number. The *R* represents a decimal point and is used when the resistor value is less than 10 ohms. For example, 4R7 represents 4.7 ohms.

The five-digit numbering system is similar to the three- and four-digit systems. The first four digits represent significant digits while the last digit indicates the number of zeros to be added. For values of less than 1000 ohms, the *R* is used to designate a decimal point.

Surface-mount resistors are identified similar to the letter and number system. The part number of the resistor is interpreted as follows; the number will vary between manufacturers. For example, RC0402J103T has the following meaning:

RC	Chip resistor
0402	Size (0.40" × 0.02")
J	Tolerance (J = ±5%, F = ±1%, D = ±0.5%, B = ±0.1%)
103	Resistance (three- or four-digit code available)
T	Packaging method

The resistance value is indicated by three or four digits. In either case, the last digit indicates the number of zeros to be added to the preceding

FIGURE 4-17

Potentiometers (variable resistors) are also labeled with their values.



digits. In the example given, the first two digits are 1 and 0 followed by 3 zeroes for a value of 10,000 ohms. For values of less than 100 or 1000 (depending on the number of digits used), *D* is used to designate the decimal point. For example, 3D9 would represent 3.9 ohms. A zero-ohm resistor or jumper is designated as 000.

Potentiometers (variable resistors) are also imprinted with their values (Figure 4-17). These may be their actual values or an alphanumeric code. With the alphanumeric code system, the resistance value is determined from the last part of the code. For example, in MTC253L4, the number 253 means 25 followed by three zeros, or 25,000 ohms. The L4 indicates the resistor construction and body type.

4-4 QUESTIONS

1. Write the color code from memory.
2. What do the four bands on a carbon composition resistor represent?

3. Decode the following resistors:

1st Band	2nd Band	3rd Band	4th Band
a. Brown	Black	Red	Silver
b. Blue	Green	Orange	Gold
c. Orange	White	Yellow	(None)
d. Red	Red	Red	Silver
e. Yellow	Violet	Brown	Gold

4. What does a fifth band on a resistor indicate?

5. What does a gold or silver third band represent?

4-5 CONNECTING RESISTORS

There are three important types of resistive circuits: the **series circuit**, the **parallel circuit**, and the **series-parallel circuit** (Figure 4-18). A *series circuit* provides a single path for current flow. A *parallel circuit* provides two or more paths for current flow. A *series-parallel circuit* is a combination of a series circuit and a parallel circuit.

4-5 QUESTION

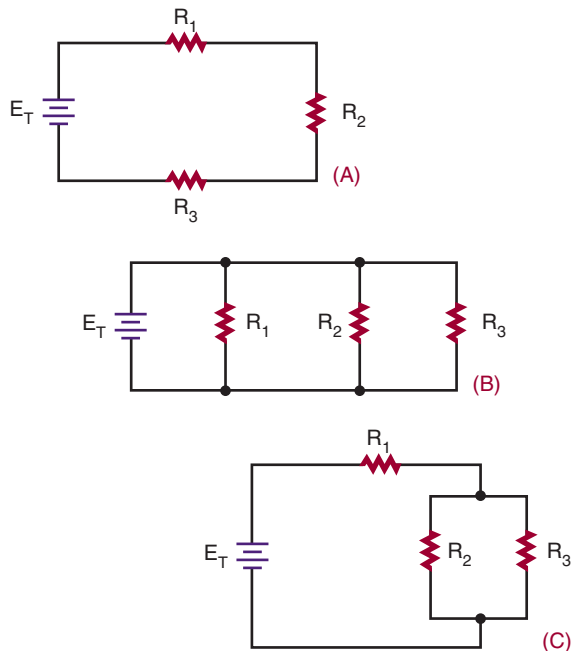
1. What are the three basic types of circuit configurations?

4-6 CONNECTING RESISTORS IN SERIES

A series circuit contains two or more resistors and provides one path for current to flow. The current flows from the negative side of the voltage source through each resistor to the positive side of the voltage source. If there is only one path for current to flow between two points in a circuit, the circuit is a series circuit.

FIGURE 4-18

Three types of resistive circuits: (A) series circuit, (B) parallel circuit, (C) series-parallel circuit.



The more resistors connected in series, the more opposition there is to current flow. The more opposition there is to current flow, the higher the resistance in the circuit. In other words, when a resistor is added in series to a circuit, the total resistance in the circuit increases. The total resistance in a series circuit is the sum of the individual resistances in the circuit. This can be expressed as:

$$R_T = R_1 + R_2 + R_3 \dots + R_n$$

The numerical subscripts refer to the individual resistors in the circuit. R_n is the last resistor in the circuit. The symbol R_T represents the total resistance in the circuit.

EXAMPLE: What is the total resistance of the circuit shown in Figure 4-19?

FIGURE 4-19

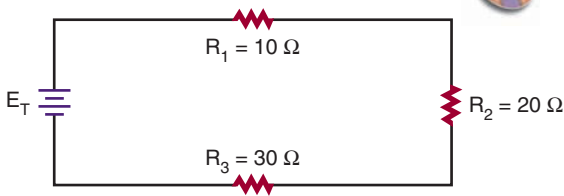
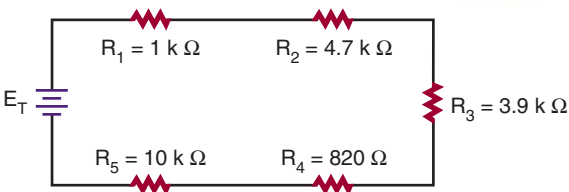


FIGURE 4-20



Given:

$$\begin{aligned} R_T &= ? \\ R_1 &= 10 \text{ ohms} \\ R_2 &= 20 \text{ ohms} \\ R_3 &= 30 \text{ ohms} \end{aligned}$$

Solution:

$$\begin{aligned} R_T &= R_1 + R_2 + R_3 \\ R_T &= 10 + 20 + 30 \\ R_T &= 60 \text{ ohms} \end{aligned}$$

EXAMPLE: Calculate the total resistance for the circuit shown in Figure 4-20.

Given:

$$\begin{aligned} R_T &= ? \\ R_1 &= 1 \text{ kilohm} \\ R_2 &= 4.7 \text{ kilohms} \\ R_3 &= 3.9 \text{ kilohms} \\ R_4 &= 820 \text{ ohms} \\ R_5 &= 10 \text{ kilohms} \end{aligned}$$

Solution:

$$\begin{aligned} R_T &= R_1 + R_2 + R_3 + R_4 + R_5 \\ R_T &= 1 \text{ k} + 4.7 \text{ k} + 3.9 \text{ k} + 0.82 \text{ k} + 10 \text{ k} \\ R_T &= 1000 + 4700 + 3900 + 820 + 10,000 \\ R_T &= 20,420 \text{ ohms} \end{aligned}$$

4-6 QUESTIONS

- Write the formula for determining total resistance in a series circuit.
- What is the total resistance of a circuit with three resistors—1500 ohms, 3300 ohms, and 4700 ohms—connected in series?
(First draw the circuit.)

4-7 CONNECTING RESISTORS IN PARALLEL

A parallel circuit contains two or more resistors and provides two or more paths for current to flow. Each current path in a parallel circuit is called a *branch*. The current flows from the negative side of the voltage source, through each branch of the parallel circuit, to the positive side of the voltage source. If there is more than one path for current to flow between two points in a circuit with two or more resistors, the circuit is a parallel circuit.

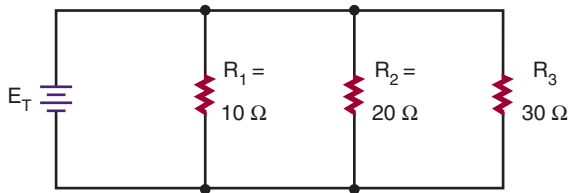
The more resistors are connected in parallel, the less opposition there is to current flow. The less opposition there is to current flow, the lower the resistance in the circuit. In other words, when a resistor is added in parallel to a circuit, the total resistance in the circuit decreases, because additional paths for current flow are provided. In a parallel circuit, the total resistance is always less than the resistance of any branch.

The total resistance in a parallel circuit is given by the formula:

$$\frac{1}{R_T} = \frac{1}{R_1} + \frac{1}{R_2} + \frac{1}{R_3} \dots + \frac{1}{R_n}$$

Again, R_T is the total resistance, R_1 , R_2 , and R_3 are the individual (branch) resistors, and R_n is the number of the last resistor in the circuit.

FIGURE 4-21



EXAMPLE: What is the total resistance of the circuit shown in Figure 4-21?

Given:

$$\begin{aligned} R_T &= ? \\ R_1 &= 10\ \text{ohms} \\ R_2 &= 20\ \text{ohms} \\ R_3 &= 30\ \text{ohms} \end{aligned}$$

Solution:

$$\frac{1}{R_T} = \frac{1}{R_1} + \frac{1}{R_2} + \frac{1}{R_3}$$

$$\frac{1}{R_T} = \frac{1}{10} + \frac{1}{20} + \frac{1}{30} \quad (\text{common denominator is } 60)$$

$$\frac{1}{R_T} = \frac{6}{60} + \frac{3}{60} + \frac{2}{60}$$

$$\frac{1}{R_T} = \frac{11}{60}$$

$$\frac{1}{R_T} = \frac{11}{60}$$

$$(11)(R_T) = (1)(60)$$

$$11R_T = 60$$

$$\cancel{11} R_T = \frac{60}{\cancel{11}} \quad (\text{divide both sides by } 11)$$

$$1R_T = \frac{60}{11}$$

$$R_T = 5.45\ \text{ohms}$$

Note that the total resistance is less than that of the smallest resistor. The circuit shown in Figure 4-21 could be replaced with one 5.45-ohm resistor.

EXAMPLE: Calculate the total resistance for the circuit shown in Figure 4-22.

Given:

$$\begin{aligned} R_T &= ? \\ R_1 &= 1\ \text{kilohm (1000 ohms)} \\ R_2 &= 4.7\ \text{kilohms (4700 ohms)} \\ R_3 &= 3.9\ \text{kilohms (3900 ohms)} \\ R_4 &= 820\ \text{ohms} \\ R_5 &= 10\ \text{kilohms (10,000 ohms)} \end{aligned}$$

Solution:

$$\frac{1}{R_T} = \frac{1}{R_1} + \frac{1}{R_2} + \frac{1}{R_3} + \frac{1}{R_4} + \frac{1}{R_5}$$

$$\frac{1}{R_T} = \frac{1}{1000} + \frac{1}{4700} + \frac{1}{3900} + \frac{1}{820} + \frac{1}{10,000}$$

It is too complicated to find a common denominator, so work with decimals.

$$\frac{1}{R_T} = 0.001 + 0.000213 + 0.000256$$

$$+ 0.00122 + 0.0001$$

$$\frac{1}{R_T} = 0.002789$$

$$\frac{1}{R_T} = \frac{0.002789}{1}$$

$$\frac{1}{R_T} \times \frac{0.002789}{0.002789} = \frac{0.002789}{1} \quad (\text{cross multiply})$$

$$(0.002789)(R_T) = (1)(1)$$

$$0.002789 R_T = 1$$

$$\frac{0.002789 R_T}{0.002789} = \frac{1}{0.002789} \quad (\text{divide both sides by } 0.002789)$$

$$1R_T = \frac{1}{0.002789}$$

$$R_T = 358.55\ \Omega$$

NOTE: HOW MANY PLACES EACH NUMBER IS ROUNDED OFF WILL SIGNIFICANTLY AFFECT THE ACCURACY OF THE FINAL ANSWER.

EXAMPLE: What resistor value must be connected in parallel with a 47-ohm resistor to provide a total resistance of 27 ohms? See Figure 4-23.

FIGURE 4-22

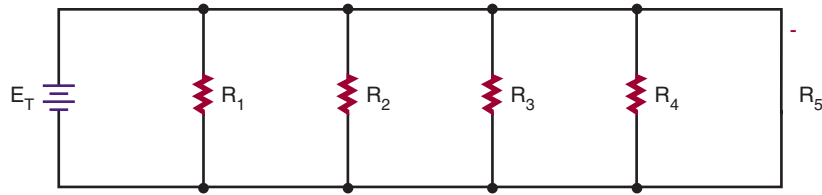
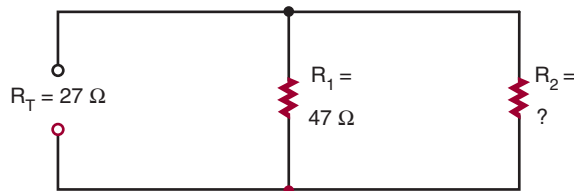


FIGURE 4-23



Given:

$$R_T = 27 \text{ ohms}$$

$$R_1 = 47 \text{ ohms}$$

$$R_2 = ?$$

Solution:

$$\frac{1}{R_T} = \frac{1}{R_1} + \frac{1}{R_2}$$

$$\frac{1}{27} = \frac{1}{47} + \frac{1}{R_2}$$

$$\frac{1}{27} - \frac{1}{47} = \frac{1}{47} - \frac{1}{47} + \frac{1}{R_2} \quad \left(\text{Subtract } \frac{1}{47} \text{ from both sides}\right)$$

$$\frac{1}{27} - \frac{1}{47} = \frac{1}{R_2} \quad \left(\text{easier to work with decimals}\right)$$

$$0.0370 - 0.0213 = \frac{1}{R_2}$$

$$0.0157 = \frac{1}{R_2}$$

$$63.69 \text{ ohms} = R_2$$

Note that 63.69 ohms is not a standard resistor value. Use the closest standard resistor value, which is 62 ohms.

4-7 QUESTIONS

1. Write the formula for determining total resistance in a parallel circuit.
2. What is the total resistance of a circuit with three resistors—1500 ohms, 3300 ohms, and 4700 ohms—connected in parallel? (*First draw the circuit.*)

4-8 CONNECTING RESISTORS IN SERIES AND PARALLEL

A series-parallel circuit is a combination of a series and a parallel circuit. Figure 4-24 shows a simple series-parallel circuit with resistors. Notice that R_2 and R_3 are in parallel, and that this parallel combination is in series with R_1 and R_4 . The current flows from the negative side of the voltage source through resistor R_4 and divides at point A to flow through the two branches, R_2 and R_3 . At point B, the current recombines and flows through R_1 .

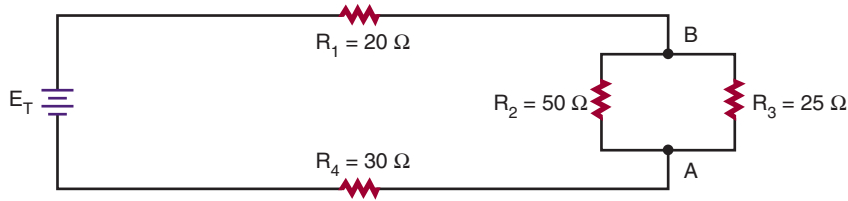
The total resistance for a series-parallel circuit or compound circuit is computed using the series formula:

$$R_T = R_1 + R_2 + R_3 \dots + R_n$$

and the parallel formula:

$$\frac{1}{R_T} = \frac{1}{R_1} + \frac{1}{R_2} + \frac{1}{R_3} \dots + \frac{1}{R_n}$$

FIGURE 4-24



Most circuits can be broken down to a simple parallel or series circuit. The procedure is as follows:

1. Calculate the parallel portion of the circuit first to determine the equivalent resistance.
2. If there are series components within the parallel portion of the circuit, determine the equivalent resistance for the series components first.
3. After the equivalent resistance is determined, redraw the circuit, substituting the equivalent resistance for the parallel portion of the circuit.
4. Do final calculations.

EXAMPLE: What is the total resistance for the circuit shown in Figure 4-24?

The first step is to determine the equivalent resistance (R_A) for R_2 and R_3 .

Given:

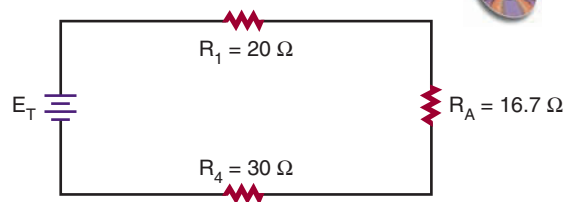
$$\begin{aligned} R_A &= ? \\ R_2 &= 50 \text{ ohms} \\ R_3 &= 25 \text{ ohms} \end{aligned}$$

Solution:

$$\begin{aligned} \frac{1}{R_A} &= \frac{1}{R_2} + \frac{1}{R_3} \\ \frac{1}{R_A} &= \frac{1}{50} + \frac{1}{25} \\ R_A &= 16.7 \text{ ohms} \end{aligned}$$

Redraw the circuit, substituting the equivalent resistance for the parallel portion of the circuit. See Figure 4-25.

FIGURE 4-25



Now determine the total series resistance for the redrawn circuit.

Given:

$$\begin{aligned} R_T &= ? \\ R_1 &= 20 \text{ ohms} \\ R_A &= 16.7 \text{ ohms} \\ R_4 &= 30 \text{ ohms} \end{aligned}$$

Solution:

$$\begin{aligned} R_T &= R_1 + R_A + R_4 \\ R_T &= 20 + 16.7 + 30 \\ R_T &= 66.7 \text{ ohms} \end{aligned}$$

EXAMPLE: Calculate the total resistance for the circuit shown in Figure 4-26.

First find the equivalent resistance (R_A) for parallel resistors R_2 and R_3 . Then find the equivalent resistance (R_B) for resistors R_5 , R_6 , and R_7 .

Given:

$$\begin{aligned} R_A &= ? \\ R_2 &= 47 \text{ ohms} \\ R_3 &= 62 \text{ ohms} \end{aligned}$$

Solution:

$$\begin{aligned} \frac{1}{R_A} &= \frac{1}{R_2} + \frac{1}{R_3} \\ \frac{1}{R_A} &= \frac{1}{47} + \frac{1}{62} \\ R_A &= 26.7 \text{ ohms} \end{aligned}$$

FIGURE 4-26

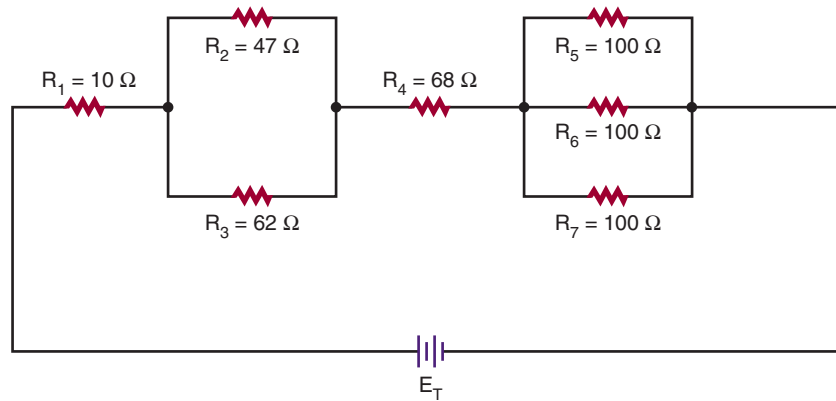
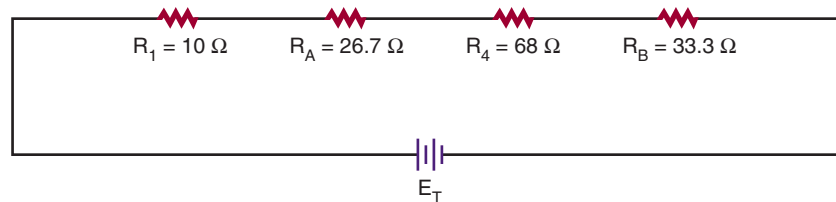


FIGURE 4-27



Given:

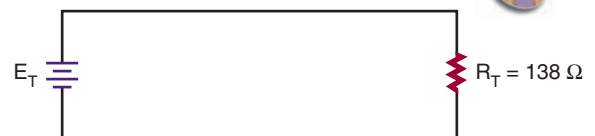
$$\begin{aligned} R_B &= ? \\ R_5 &= 100 \text{ ohms} \\ R_6 &= 100 \text{ ohms} \\ R_7 &= 100 \text{ ohms} \end{aligned}$$

Solution:

$$\begin{aligned} \frac{1}{R_B} &= \frac{1}{R_5} + \frac{1}{R_6} + \frac{1}{R_7} \\ \frac{1}{R_B} &= \frac{1}{100} + \frac{1}{100} + \frac{1}{100} \\ R_B &= 33.3 \text{ ohms} \end{aligned}$$

Now redraw the circuit using equivalent resistance R_A and R_B and determine the total series resistance for the redrawn circuit. See Figure 4-27.

FIGURE 4-28



Given:

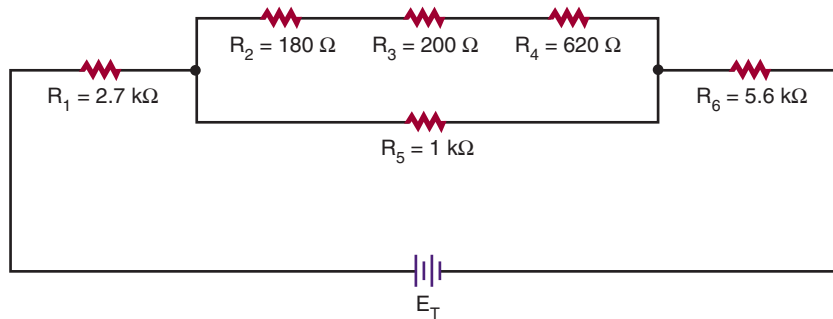
$$\begin{aligned} R_T &= ? \\ R_1 &= 10 \text{ ohms} \\ R_A &= 26.7 \text{ ohms} \\ R_4 &= 68 \text{ ohms} \\ R_B &= 33.3 \text{ ohms} \end{aligned}$$

Solution:

$$\begin{aligned} R_T &= R_1 + R_A + R_4 + R_B \\ R_T &= 10 + 26.7 + 68 + 33.3 \\ R_T &= 138 \text{ ohms} \end{aligned}$$

The circuit shown in Figure 4-26 could be replaced with a single resistor of 138 ohms (Figure 4-28).

FIGURE 4-29



EXAMPLE: Find the total resistance for the circuit shown in Figure 4-29.

The equivalent resistance of the series in the parallel portion of the circuit must be determined first. This is labeled R_S .

Given:

$$R_S = ?$$

$$R_2 = 180 \text{ ohms}$$

$$R_3 = 200 \text{ ohms}$$

$$R_4 = 620 \text{ ohms}$$

Solution:

$$R_S = R_2 + R_3 + R_4$$

$$R_S = 180 + 200 + 620$$

$$R_S = 1000 \text{ ohms}$$

Redraw the circuit, substituting equivalent resistance R_S for the series resistors R_2 , R_3 , and R_4 . See Figure 4-30.

Determine the equivalent parallel resistance R_A for R_S and R_5 .

Given:

$$R_A = ?$$

$$R_S = 1000 \text{ ohms}$$

$$R_5 = 1000 \text{ ohms}$$

Solution:

$$\frac{1}{R_A} = \frac{1}{R_S} + \frac{1}{R_5}$$

$$\frac{1}{R_A} = \frac{1}{1000} + \frac{1}{1000}$$

$$R_A = 500 \text{ ohms}$$

Redraw the circuit again, substituting equivalent resistance R_A for parallel resistors R_S and R_5 , and determine the total series resistance for the redrawn circuit. See Figure 4-31.

Given:

$$R_T = ?$$

$$R_1 = 2700 \text{ ohms}$$

$$R_A = 500$$

$$R_6 = 5600 \text{ ohms}$$

Solution:

$$R_T = R_1 + R_A + R_6$$

$$R_T = 2700 + 500 + 5600$$

$$R_T = 8800 \text{ ohms}$$

The circuit shown in Figure 4-29 can be replaced with a single resistor of 8800 ohms (Figure 4-32).

FIGURE 4-30

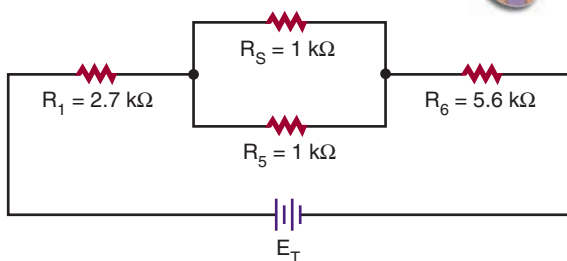


FIGURE 4-31

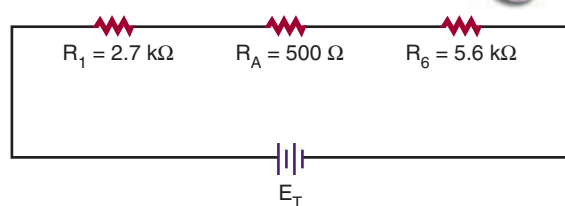
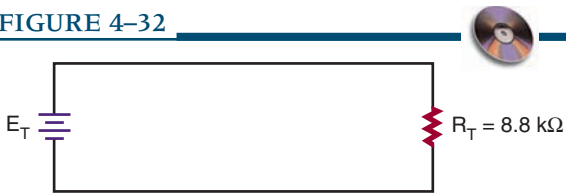


FIGURE 4-32



4-8 QUESTION

1. What is the total resistance of a circuit with a 1500-ohm and a 3300-ohm resistor in parallel connected in series with a 4700-ohm resistor? (First draw the circuit.)

SUMMARY

- Resistors are either fixed or variable.
 - The tolerance of a resistor is the amount that its resistance can vary and still be acceptable.
 - Resistors are either carbon composition, wirewound, or film.
 - Carbon composition resistors are the most commonly used resistors.
 - Wirewound resistors are used in high-current circuits that must dissipate large amounts of heat.
 - Film resistors offer small size with high accuracy.
 - Variable resistors used to control voltage are called potentiometers.
 - Variable resistors used to control current are called rheostats.
- Resistor values may be identified by colored bands:
 - The first band represents the first digit.
 - The second band represents the second digit.
 - The third band represents the number of zeros to be added to the first two digits.
 - The fourth band represents the tolerance.
 - A fifth band may be added to represent reliability.
 - Resistor values of less than 100 ohms are shown by a black third band.
 - Resistors may be placed in three configurations—series, parallel, and compound.
 - Resistor values of less than 10 ohms are shown by a gold third band.
 - Resistor values of less than 1 ohm are shown by a silver third band.
 - Resistor values for 1% tolerance resistors are shown with the fourth band as the multiplier.
 - Resistor values may also be identified by an alphanumerical system.
 - The total resistance in a series circuit can be found by the formula:

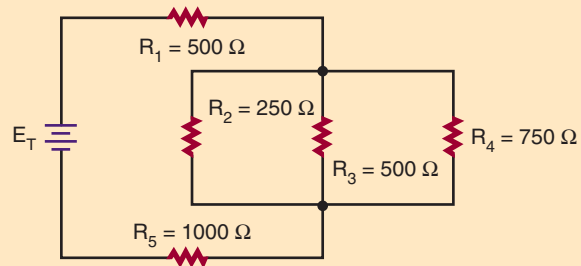
$$R_T = R_1 + R_2 + R_3 \dots + R_n$$
 - The total resistance in a parallel circuit can be found by the formula:

$$\frac{1}{R_T} = \frac{1}{R_1} + \frac{1}{R_2} + \frac{1}{R_3} \dots + \frac{1}{R_n}$$
 - The total resistance in a series-parallel circuit is determined by both series and parallel formulas.

CHAPTER 4 SELF-TEST

1. Describe how the resistance of a material is determined.
2. What is the tolerance range of a 2200-ohm resistor with a 10% tolerance?

3. Write the color codes for the following resistors:
 - a. 5600 ohms $\pm 5\%$
 - b. 1.5 megohms $\pm 10\%$
 - c. 2.7 ohms $\pm 5\%$
 - d. 100 ohms $\pm 20\%$
 - e. 470 kilohms $\pm 10\%$
4. Determine the total resistance for the circuit shown.
5. Describe how current flows through a series-parallel circuit.



Ohm's Law

OBJECTIVES

After completing this chapter, the student should be able to:

- Identify the three basic parts of a circuit.
- Identify three types of circuit configurations.
- Describe how current flow can be varied in a circuit.
- State Ohm's law with reference to current, voltage, and resistance.
- Solve problems using Ohm's law for current, resistance, or voltage in series, parallel, and series-parallel circuits.
- Describe how the total current flow differs between series and parallel circuits.
- Describe how the total voltage drop differs between series and parallel circuits.
- Describe how the total resistance differs between series and parallel circuits.
- State and apply Kirchhoff's current and voltage laws.
- Verify answers using Ohm's law with Kirchhoff's law.



See accompanying CD for interactive presentations, tutorials and Ohm's Law examples in MultiSim, Chapter 5.

Ohm's law defines the relationship among three fundamental quantities: current, voltage, and resistance. It states that current is directly proportional to voltage and inversely proportional to resistance.

This chapter examines Ohm's law and how it is applied to a circuit. Some of the concepts are introduced in previous chapters.

5-1 ELECTRIC CIRCUITS

As stated earlier, current flows from a point with an excess of electrons to a point with a deficiency of electrons. The path that the current follows is called an *electric circuit*. All electric circuits consist of a voltage source, a load, and a conductor. The *voltage source* establishes a difference of potential

that forces the current to flow. The source can be a battery, a generator, or another of the devices described in Chapter 3, Voltage. The *load* consists of some type of resistance to current flow. The resistance may be high or low depending on the purpose of the circuit. The current in the circuit flows through a *conductor* from the source to the load. The conductor must give up electrons easily. Copper is used for most conductors.

The path the electric current takes to the load may be through any of three types of circuits: a series circuit, a parallel circuit, or a series-parallel circuit. A series circuit (Figure 5-1) offers a single continuous path for the current flow, going from the source to the load. A parallel circuit (Figure 5-2) offers more than one path for current flow. It allows the source to apply voltage to more than one load. It also allows several sources to be connected to a

FIGURE 5-1

A series circuit offers a single path for current flow.

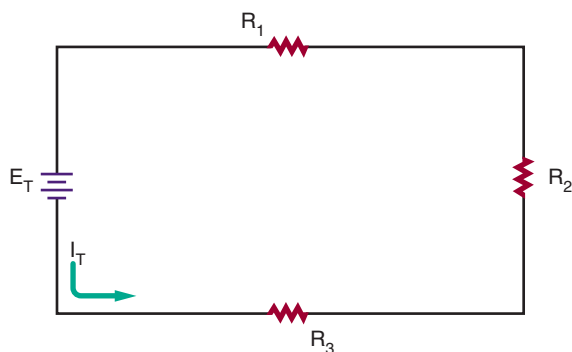


FIGURE 5-2

A parallel circuit offers more than one path for current flow.

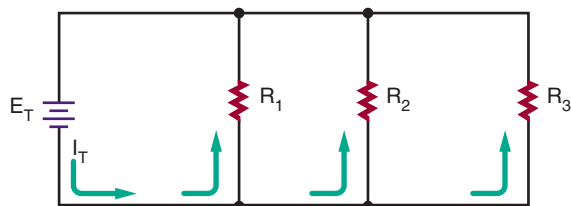


FIGURE 5-3

A series-parallel circuit is a combination of a series circuit and a parallel circuit.

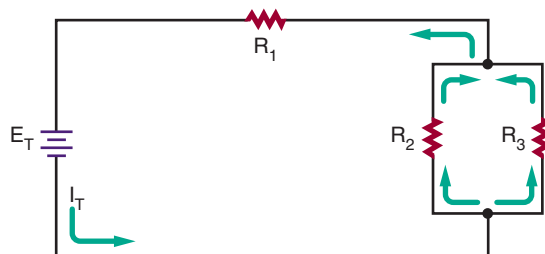


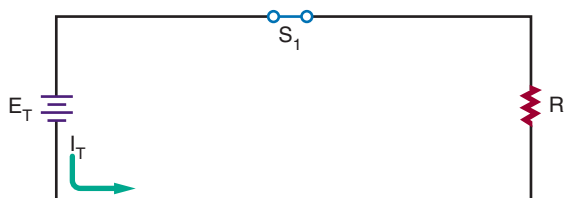
FIGURE 5-4

Current flow in an electric circuit flows from the negative side of the voltage source, through the load, and returns to the voltage source through the positive terminal.



FIGURE 5-5

A closed circuit supports current flow.



single load. A series-parallel circuit (Figure 5-3) is a combination of the series and parallel circuit.

Current in an electric circuit flows from the negative side of the voltage source through the load to the positive side of the voltage source (Figure 5-4). As long as the path is not broken, it is a closed circuit and current flows (Figure 5-5). However, if the path is broken, it is an open circuit and no current can flow (Figure 5-6).

FIGURE 5-6

An open circuit does not support current flow.

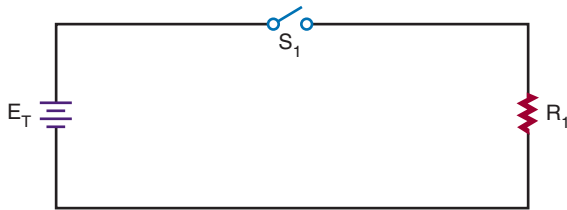


FIGURE 5-7

Current flow in an electric circuit can be changed by varying the voltage.



The current flow in an electric circuit can be varied by changing either the voltage applied to the circuit or the resistance in the circuit. The current changes in exact proportions to the change in the voltage or resistance. If the voltage is increased, the current also increases. If the voltage is decreased, the current also decreases (Figure 5-7). On the other hand, if the resistance is increased, the current decreases (Figure 5-8). This relationship of voltage, current, and resistance is called Ohm's law.

5-1 QUESTIONS

1. What are the three basic parts of an electric circuit?
2. Define the following:
 - a. Series circuit
 - b. Parallel circuit
 - c. Series-parallel circuit

FIGURE 5-8

Current flow in an electric circuit can also be changed by varying the resistance in the circuit.



3. Draw a diagram of a circuit showing how current would flow through the circuit. (Use arrows to indicate current flow.)
4. What is the difference between an open circuit and a closed circuit?
5. What happens to the current in an electric circuit when the voltage is increased? When it is decreased? When the resistance is increased? When it is decreased?

5-2 OHM'S LAW

Ohm's law, or the relationship among current, voltage, and resistance, was first observed by George Ohm in 1827. **Ohm's law** states that the current in an electric circuit is directly proportional to the voltage and inversely proportional to the resistance in a circuit. This may be expressed as:

$$\text{current} = \frac{\text{voltage}}{\text{resistance}}$$

or

$$I = \frac{E}{R}$$

where: I = current in amperes
 E = voltage in volts
 R = resistance in ohms

FIGURE 5-9

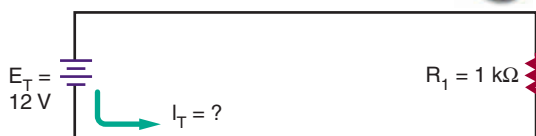
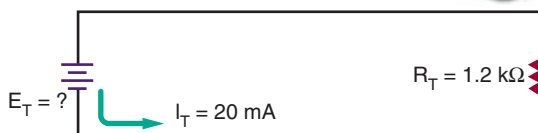


FIGURE 5-10



Whenever two of the three quantities are known, the third quantity can always be determined.

EXAMPLE: How much current flows in the circuit shown in Figure 5-9?

Given:

$$\begin{aligned} I_T &= ? \\ E_T &= 12 \text{ volts} \\ R_T &= 1000 \text{ ohms} \end{aligned}$$

Solution:

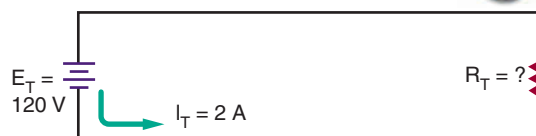
$$\begin{aligned} I_T &= \frac{E_T}{R_T} \\ I_T &= \frac{12}{1000} \\ I_T &= 0.012 \text{ amp or 12 milliamps} \end{aligned}$$

EXAMPLE: In the circuit shown in Figure 5-10, how much voltage is required to produce 20 milliamps of current flow?

Given:

$$\begin{aligned} I_T &= 20 \text{ mA} = 0.02 \text{ amp} \\ E_T &= ? \\ R_T &= 1.2 \text{ k}\Omega = \text{ohms} \end{aligned}$$

FIGURE 5-11



Solution:

$$\begin{aligned} I_T &= \frac{E_T}{R_T} \\ 0.02 &= \frac{E_T}{1200} \\ E_T &= 24 \text{ volts} \end{aligned}$$

EXAMPLE: What resistance value is needed for the circuit shown in Figure 5-11 to draw 2 amperes of current?

Given:

$$\begin{aligned} I_T &= 2 \text{ amps} \\ E_T &= 120 \text{ volts} \\ R_T &= ? \end{aligned}$$

Solution:

$$\begin{aligned} I_T &= \frac{E_T}{R_T} \\ 2 &= \frac{120}{R_T} \\ 60 \text{ ohms} &= R_T \end{aligned}$$

5-2 QUESTIONS

1. State Ohm's law as a formula.
2. How much current flows in a circuit with 12 volts applied and a resistance of 2400 ohms?
3. How much resistance is required to limit current flow to 20 milliamperes with 24 volts applied?

4. How much voltage is needed to produce 3 amperes of current flow through a resistance of 100 ohms?

5-3 APPLICATION OF OHM'S LAW

In a series circuit (Figure 5-12), the same current flows throughout the circuit.

$$I_T = I_{R_1} = I_{R_2} = I_{R_3} \dots = I_{R_n}$$

The total voltage in a series circuit is equal to the voltage drop across the individual loads (resistance) in the circuit.

$$E_T = E_{R_1} + E_{R_2} + E_{R_3} \dots + E_{R_n}$$

The total resistance in a series circuit is equal to the sum of the individual resistances in the circuit.

$$R_T = R_1 + R_2 + R_3 \dots + R_n$$

In a parallel circuit (Figure 5-13), the same voltage is applied to each branch in the circuit.

$$E_T = E_{R_1} = E_{R_2} = E_{R_3} \dots = E_{R_n}$$

The total current in a parallel circuit is equal to the sum of the individual branch currents in the circuit.

$$I_T = I_{R_1} + I_{R_2} + I_{R_3} \dots + I_{R_n}$$

FIGURE 5-12
In a series circuit, the current flow is the same throughout the circuit.

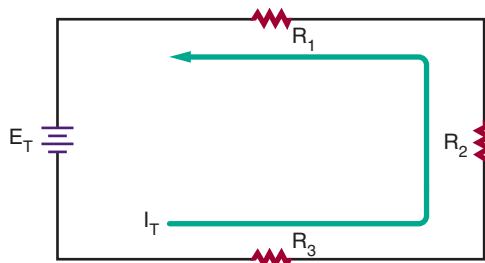
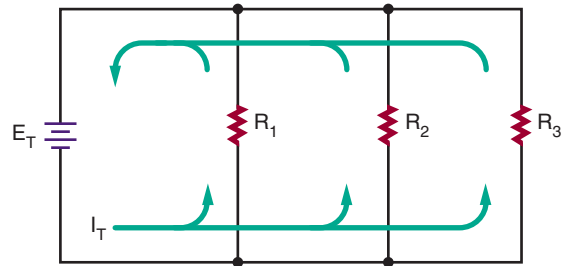


FIGURE 5-13

In a parallel circuit, the current divides among the branches of the circuit and recombines on returning to the voltage source.



The reciprocal of the total resistance is equal to the sum of the reciprocals of the individual branch resistances.

$$\frac{1}{R_T} = \frac{1}{R_1} + \frac{1}{R_2} + \frac{1}{R_3} \dots + \frac{1}{R_n}$$

The total resistance in a parallel circuit will always be smaller than the smallest branch resistance.

Ohm's law states that the current in a circuit (series, parallel, or series-parallel) is directly proportional to the voltage and inversely proportional to the resistance.

$$I = \frac{E}{R}$$

In determining unknown quantities in a circuit, follow these steps:

1. Draw a schematic of the circuit and label all known quantities.
2. Solve for equivalent circuits and redraw the circuit.
3. Solve for the unknown quantities.

NOTE: OHM'S LAW IS TRUE FOR ANY POINT IN A CIRCUIT AND CAN BE APPLIED AT ANY TIME. THE SAME CURRENT FLOWS THROUGHOUT A SERIES CIRCUIT AND THE SAME VOLTAGE IS PRESENT AT ANY BRANCH OF A PARALLEL CIRCUIT.

FIGURE 5-14

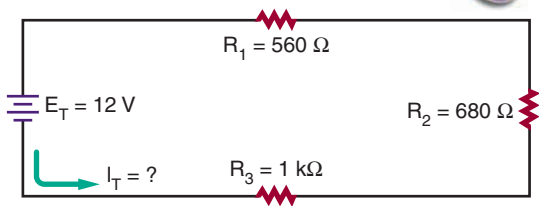
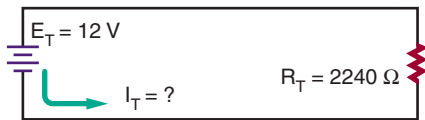


FIGURE 5-15



EXAMPLE: What is the total current flow in the circuit shown in Figure 5-14?

Given:

$$\begin{aligned} I_T &= ? \\ E_T &= 12 \text{ volts} \\ R_T &= ? \\ R_1 &= 560 \text{ ohms} \\ R_2 &= 680 \text{ ohms} \\ R_3 &= 1 \text{ k}\Omega = 1000 \text{ ohms} \end{aligned}$$

Solution:

First solve for the total resistance of the circuit:

$$\begin{aligned} R_T &= R_1 + R_2 + R_3 \\ R_T &= 560 + 680 + 1000 \\ R_T &= 2240 \text{ ohms} \end{aligned}$$

Draw an equivalent circuit. See Figure 5-15.

Now solve for the total current flow:

$$\begin{aligned} I_T &= \frac{E_T}{R_T} \\ I_T &= \frac{12}{2240} \\ I_T &= 0.0054 \text{ amp or } 5.4 \text{ milliamp} \end{aligned}$$

EXAMPLE: How much voltage is dropped across resistor R_2 in the circuit shown in Figure 5-16?

FIGURE 5-16

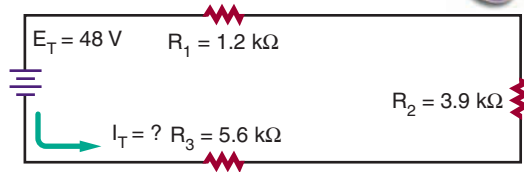
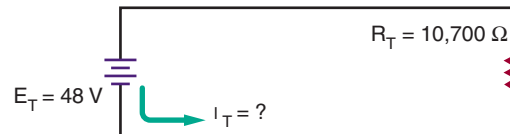


FIGURE 5-17



Given:

$$\begin{aligned} I_T &= ? \\ E_T &= 48 \text{ volts} \\ R_T &= ? \\ R_1 &= 1.2 \text{ k}\Omega = 1200 \text{ ohms} \\ R_2 &= 3.9 \text{ k}\Omega = 3900 \text{ ohms} \\ R_3 &= 5.6 \text{ k}\Omega = 5600 \text{ ohms} \end{aligned}$$

Solution:

First solve for the total circuit resistance:

$$\begin{aligned} R_T &= R_1 + R_2 + R_3 \\ R_T &= 1200 + 3900 + 5600 \\ R_T &= 10,700 \text{ ohms} \end{aligned}$$

Draw the equivalent circuit. See Figure 5-17.

Solve for the total current in the circuit:

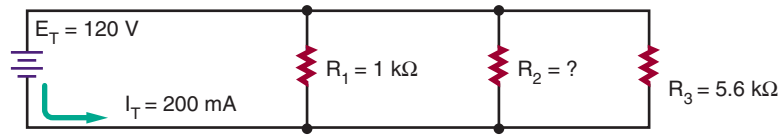
$$\begin{aligned} I_T &= \frac{E_T}{R_T} \\ I_T &= \frac{48}{10,700} \end{aligned}$$

$$I_T = 0.0045 \text{ amp or } 4.5 \text{ milliamps}$$

Remember, in a series circuit, the same current flows throughout the circuit. Therefore, $I_{R_2} = I_T$.

$$\begin{aligned} I_{R_2} &= \frac{E_{R_2}}{R_2} \\ 0.0045 &= \frac{E_{R_2}}{3900} \\ E_{R_2} &= 17.55 \text{ volts} \end{aligned}$$

FIGURE 5-18



EXAMPLE: What is the value of R_2 in the circuit shown in Figure 5-18?

First solve for the current that flows through R_1 and R_3 . Because the voltage is the same in each branch of a parallel circuit, each branch voltage is equal to the source voltage of 120 volts.

Given:

$$I_{R_1} = ?$$

$$E_{R_1} = 120\text{ volts}$$

$$R_1 = 1000\text{ ohms}$$

Given:

$$I_{R_3} = ?$$

$$E_{R_3} = 120\text{ volts}$$

$$R_3 = 5600\text{ ohms}$$

Solution:

$$I_{R_1} = \frac{E_{R_1}}{R_1}$$

$$I_{R_1} = \frac{120}{1000}$$

$$I_{R_1} = 0.12\text{ amp}$$

Solution:

$$I_{R_3} = \frac{E_{R_3}}{R_3}$$

$$I_{R_3} = \frac{120}{5600}$$

$$I_{R_3} = 0.021\text{ amp}$$

In a parallel circuit, the total current is equal to the sum of the currents in the branch currents.

Given:

$$I_T = 0.200\text{ amp}$$

$$I_{R_1} = 0.120\text{ amp}$$

$$I_{R_2} = ?$$

$$I_{R_3} = 0.021\text{ amp}$$

Solution:

$$I_T = I_{R_1} + I_{R_2} + I_{R_3}$$

$$0.200 = 0.120 + I_{R_2} + 0.021$$

$$0.200 = 0.141 + I_{R_2}$$

$$0.200 - 0.141 = I_{R_2}$$

Resistor R_2 can now be determined using Ohm's law.

Given:

$$I_{R_2} = 0.059\text{ amp}$$

$$E_{R_2} = 120\text{ volts}$$

$$R_2 = ?$$

Solution:

$$I_{R_2} = \frac{E_{R_2}}{R_2}$$

$$0.059 = \frac{120}{R_2}$$

$$R_2 = 2033.9\text{ ohms}$$

EXAMPLE: What is the current through R_3 in the circuit shown in Figure 5-19?

First determine the equivalent resistance (R_A) for resistors R_1 and R_2 .

Given:

$$R_A = ?$$

$$R_1 = 1000\text{ ohms}$$

$$R_2 = 2000\text{ ohms}$$

Solution:

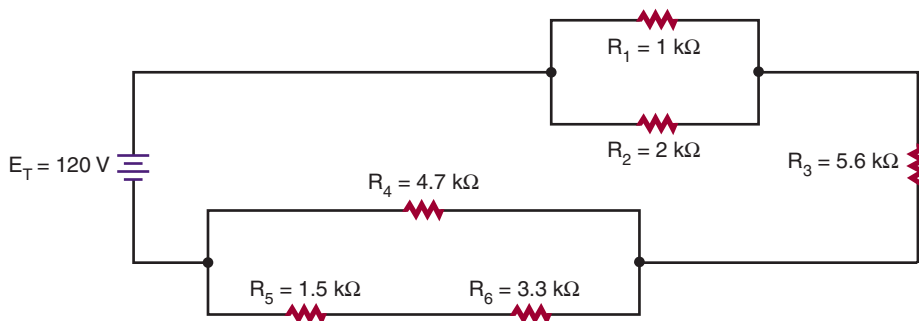
$$\frac{1}{R_A} = \frac{1}{R_1} + \frac{1}{R_2} \quad \text{(adding fractions requires a common denominator)}$$

$$\frac{1}{R_A} = \frac{1}{1000} + \frac{1}{2000}$$

$$R_A = 666.67\text{ ohms}$$

Then determine the equivalent resistance (R_B) for resistors R_4 , R_5 , and R_6 . First, find the total series resistance (R_S) for resistors R_5 and R_6 .

FIGURE 5-19



Given:

$$R_S = ?$$

$$R_5 = 1500 \text{ ohms}$$

$$R_6 = 3300 \text{ ohms}$$

Given:

$$R_B = ?$$

$$R_4 = 4700 \text{ ohms}$$

$$R_S = 4800 \text{ ohms}$$

Solution:

$$\frac{1}{R_B} = \frac{1}{R_4} + \frac{1}{R_S}$$

$$\frac{1}{R_B} = \frac{1}{4700} + \frac{1}{4800} \quad (\text{In this case, a common denominator would be too large. Use decimals!})$$

$$R_B = 2375.30 \text{ ohms}$$

Redraw the equivalent circuit substituting R_A and $R_{B'}$ and find the total series resistance of the equivalent circuit. See Figure 5-20.

Given:

$$R_T = ?$$

$$R_A = 666.67 \text{ ohms}$$

$$R_3 = 5600 \text{ ohms}$$

$$R_{B'} = 2375.30 \text{ ohms}$$

Solution:

$$R_S = R_5 + R_6$$

$$R_S = 1500 + 3300$$

$$R_S = 4800 \text{ ohms}$$

Solution:

$$R_T = R_A + R_3 + R_{B'}$$

$$R_T = 666.67 + 5600 + 2375.30$$

$$R_T = 8641.97 \text{ ohms}$$

Now solve for the total current through the equivalent circuit using Ohm's law.

Given:

$$I_T = ?$$

$$E_T = 120 \text{ volts}$$

$$R_T = 8641.97 \text{ ohms}$$

Solution:

$$I_T = \frac{E_T}{R_T}$$

$$I_T = \frac{120}{8641.97}$$

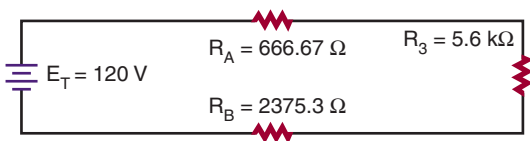
$$I_T = 0.0139 \text{ amp or } 13.9 \text{ milliamps}$$

In a series circuit, the same current flows throughout the circuit. Therefore, the current flowing through R_3 is equal to the total current in the circuit.

$$I_{R_3} = I_T$$

$$I_{R_3} = 13.9 \text{ milliamps}$$

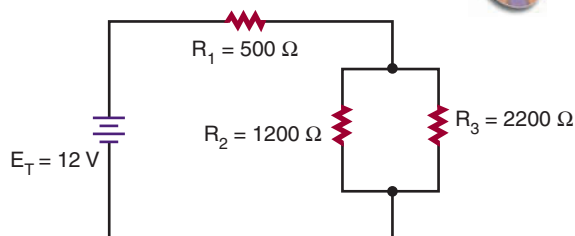
FIGURE 5-20



5-3 QUESTIONS

1. State the formulas necessary for determining total current in series and parallel circuits when the current flow

FIGURE 5-21



through the individual components is known.

2. State the formulas necessary for determining total voltage in series and parallel circuits when the individual voltage drops are known.
3. State the formulas for determining total resistance in series and parallel circuits when the individual resistances are known.
4. State the formula to solve for total current, voltage, or resistance in a series or parallel circuit when at least two of the three values (current, voltage, and resistance) are known.
5. What is the total circuit current in Figure 5-21?

$$I_T = ?$$

$$E_T = 12 \text{ volts}$$

$$R_1 = 500 \text{ ohms}$$

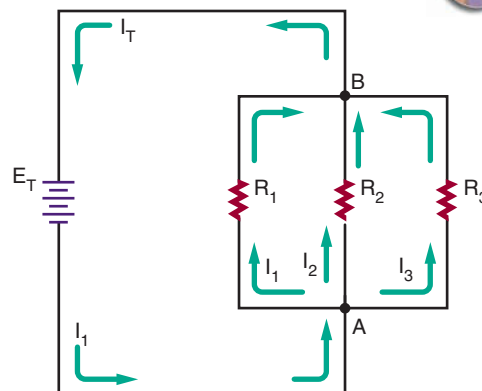
$$R_2 = 1200 \text{ ohms}$$

$$R_3 = 2200 \text{ ohms}$$

5-4 KIRCHHOFF'S CURRENT LAW

In 1847 G. R. Kirchhoff extended Ohm's law with two important statements that are referred to as Kirchhoff's laws. The first law—known as **Kirchhoff's current law**—states:

FIGURE 5-22



- The algebraic sum of all the currents entering and leaving a junction is equal to zero.

Another way of stating Kirchhoff's current law is:

- The total current flowing into a junction is equal to the sum of the current flowing out of that junction.

A junction is defined as any point of a circuit at which two or more current paths meet. In a parallel circuit, the junction is where the parallel branches of the circuit connect.

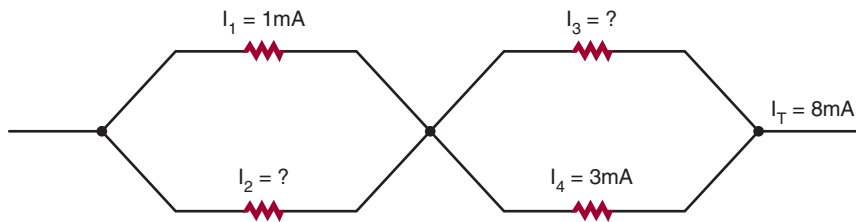
In Figure 5-22, point A is one junction and point B is the second junction. Following the current in the circuit, I_T flows from the voltage source into the junction at point A. There the current splits among the three branches as shown. Each of the three branch currents (I_1 , I_2 , and I_3) flows out of junction A. According to Kirchhoff's current law, which states that the *total current into a junction is equal to the total current out of the junction*, the current can be stated as:

$$I_T = I_1 + I_2 + I_3$$

Following the current through each of the three branches finds them coming back together at point B. Currents I_1 , I_2 , and I_3 flow into junction B, and I_T flows out. Kirchhoff's current law formula at this junction is the same as at junction A:

$$I_1 + I_2 + I_3 = I_T$$

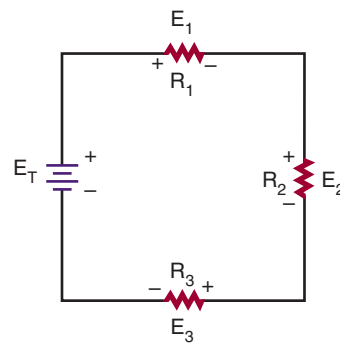
FIGURE 5-23



5-4 QUESTIONS

1. State Kirchhoff's current law.
2. A total of 3 A flows into a junction of three parallel branches. What is the sum of the three branch currents?
3. If 1 mA and 5 mA of current flow into a junction, what is the amount of current flowing out of the junction?
4. In a parallel circuit with two branches, one branch has 2 mA of current flowing through it. The total current is 5 mA. What is the current through the other branch?
5. Refer to Figure 5-23. What are the values of I_2 and I_3 ?

FIGURE 5-24



In Figure 5-24 there are three voltage drops and one voltage source (voltage rise) in the circuit. If the voltages are summed around the circuit as shown, they equal zero.

$$E_T - E_1 - E_2 - E_3 = 0$$

Notice that the voltage source (E_T) has a sign opposite that of the voltage drops. Therefore the algebraic sum equals zero.

Looking at this another way, the sum of all the voltage drops will equal the voltage source.

$$E_T = E_1 + E_2 + E_3$$

Both of the formulas shown are stating the same thing and are equivalent ways of expressing Kirchhoff's voltage law.

The key to remember is that the voltage source's polarity in the circuit is opposite to that of the voltage drops.

5-5 KIRCHHOFF'S VOLTAGE LAW

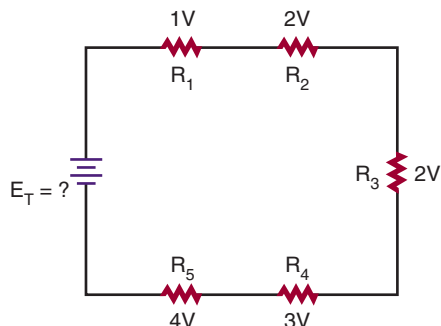
Kirchhoff's second law is referred to as **Kirchhoff's voltage law**, and it states:

- The algebraic sum of all the voltages around a closed circuit equals zero.

Another way of stating Kirchhoff's voltage law is:

- The sum of all the voltage drops in a closed circuit will equal the voltage source.

FIGURE 5–25



5–5 QUESTIONS

1. State Kirchhoff's voltage law two different ways.
2. A series resistive circuit is connected to a 12-volt voltage source. What is the total voltage drop in the circuit?
3. A series circuit has two identical resistors connected in series with a 9-volt battery. What is the voltage drop across each resistor?
4. A series circuit is connected to a 12-volt voltage source with three resistors. One resistor drops 3 V and another resistor drops 5 V. What is the voltage drop across the third resistor?
5. Refer to Figure 5–25. What is the total voltage applied to the circuit?

SUMMARY

- An electric circuit consists of a voltage source, a load, and a conductor.
- The current path in an electric circuit can be series, parallel, or series-parallel.

- A series circuit offers only one path for current to flow.
- A parallel circuit offers several paths for the flow of current.
- A series-parallel circuit provides a combination of series and parallel paths for the flow of current.
- Current flows from the negative side of the voltage source through the load to the positive side of the voltage source.
- Current flow in an electric circuit can be varied by changing either the voltage or the resistance.
- The relationship of current, voltage, and resistance is given by Ohm's law.
- Ohm's law states that the current in an electric circuit is directly proportional to the voltage applied and inversely proportional to the resistance in the circuit.

$$I = \frac{E}{R}$$

- Ohm's law applies to all series, parallel, and series-parallel circuits.
- To determine unknown quantities in a circuit:
 - Draw a schematic of the circuit and label all quantities.
 - Solve for equivalent circuits and redraw the circuit.
 - Solve for all unknown quantities.
- Kirchhoff's current law: The algebraic sum of all the currents entering and leaving a junction is equal to zero; it may be restated as the total current flowing into a junction is equal to the sum of the current flowing out of that junction.
- Kirchhoff's voltage law: The algebraic sum of all the voltages around a closed circuit equals zero; it may be restated as the sum of all the voltage drops in a closed circuit will equal the voltage source.

CHAPTER 5 SELF-TEST

Using Ohm's law, find the unknown value for the following:

1. $I = ?$ $E = 9 \text{ V}$ $R = 4500 \text{ ohms}$

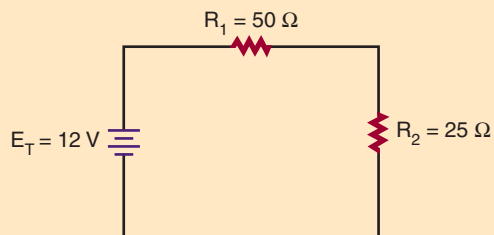
2. $I = 250 \text{ mA}$ $E = ?$ $R = 470 \text{ ohms}$

3. $I = 10 \text{ A}$ $E = 240 \text{ V}$ $R = ?$

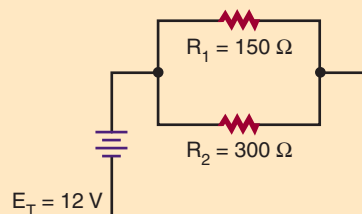
4. Find the current and voltage drop through each component for the circuits shown below.

5. Use Kirchhoff's laws to verify answers for question 4.

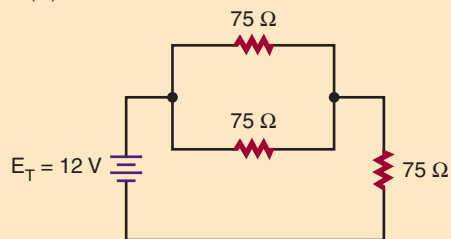
(A)



(B)



(C)



Electrical Measurements— Meters

OBJECTIVES

After completing this chapter, the student should be able to:

- Identify the two types of meter movements available.
- Describe how a voltmeter is used in a circuit.
- Describe how an ammeter is used in a circuit.
- Describe how an ohmmeter is used for measuring resistance.
- Identify the functions of a multimeter.
- Identify the advantages/disadvantages of DMMs and VOMs.
- Describe how to use a multimeter to measure voltage, current, and resistance.
- Describe how to measure current using an ammeter.
- Describe how to connect an ammeter into a circuit.
- List safety precautions for using an ammeter.
- Describe how to connect a voltmeter to an electrical circuit.
- List safety precautions for connecting a voltmeter to a circuit.
- Describe how resistance values are measured using an ohmmeter.
- Define *continuity check*.
- Describe how an ohmmeter is used to check open, short, or closed circuits.



See accompanying CD for interactive presentations and tutorials relating to Chapter 6.

In the field of electricity, accurate quantitative measurements are essential. A technician commonly works with current, voltage, and resistance. Ammeters, voltmeters, and ohmmeters are used to provide the essential measurements.

A good understanding of the design and operation of electrical measuring meters is important.

This chapter describes the more commonly used analog meters, including the multimeter or multifunction meter.

6-1 INTRODUCTION TO METERS

Meters are the means by which the invisible action of electrons can be detected and measured. Meters are indispensable in examining the operation of a circuit. Two types of meters are available. One type is the **analog meter**, which uses a graduated scale with a pointer (Figure 6-1). The other type is the **digital meter**, which provides a reading in numbers (Figure 6-2). Digital meters are easier to read and provide a more accurate reading than analog meters. However, analog meters provide a better graphic display of rapid changes in current or voltage.

FIGURE 6-1

Analog meter.



FIGURE 6-2

A digital meter.



FIGURE 6-3

Location of the zero adjustment screw on an analog meter.



ZERO ADJUSTMENT SCREW

Most meters are housed in a protective case. Terminals are provided for connecting the meter to the circuit. The polarity of the terminals must be observed for proper connection. A red terminal is positive and a black terminal is negative.

Prior to use of an analog meter, the pointer should be adjusted to zero. A small screw is located on the front of the meter to permit this adjustment (Figure 6-3). To zero the meter, place the meter in the position where it is to be used. If the needle does not point to zero, use a screwdriver to turn the screw until it does. The meter should not be connected to a circuit while this adjustment is being made.

6-1 QUESTIONS

1. What is the purpose of a meter?
2. What are the two types of meters available?
3. What colors identify the positive and negative terminals of a meter?
4. What adjustments should be made before using an analog meter?

6-2 TYPES OF METERS

An **ammeter** is used to measure current in a circuit. An ammeter (schematic symbol shown in Figure 6-4) can be considered a flow meter. It measures the number of electrons flowing past a given point in a circuit. The electrons must flow through the ammeter to obtain a reading. As shown in Figure 6-5, this is accomplished by opening the circuit and inserting the ammeter.

A **voltmeter** is used to measure the voltage (difference of potential) between two points in a circuit. A voltmeter can be considered a pressure gauge, used to measure the electrical pressure in a circuit (Figure 6-6).

Resistance is measured with an **ohmmeter**. To measure resistance, a voltage is placed across the device to be measured, inducing a current flow through the device (Figure 6-7). When there is little resistance, a large current flows and the ohmmeter registers a low resistance. When there is great resistance, a small current flows and the ohmmeter registers a high resistance.

FIGURE 6-4
Schematic symbol for an ammeter.



FIGURE 6-5
The placement of an ammeter in a circuit.

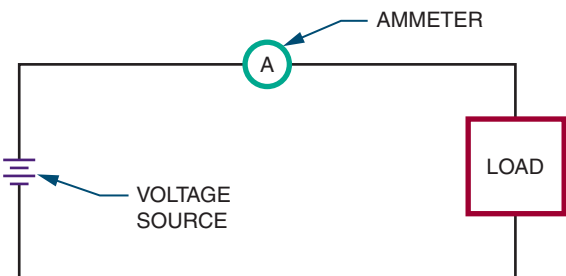


FIGURE 6-6
(A) Schematic symbol for a voltmeter. (B) A voltmeter is connected in parallel in a circuit.

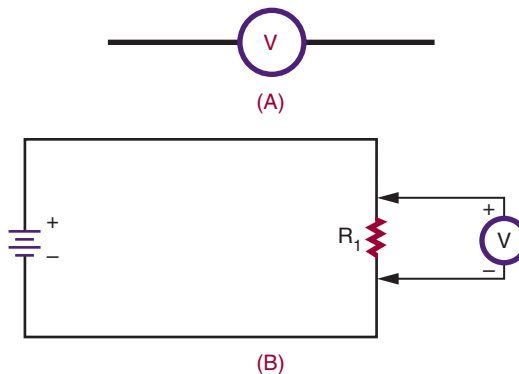
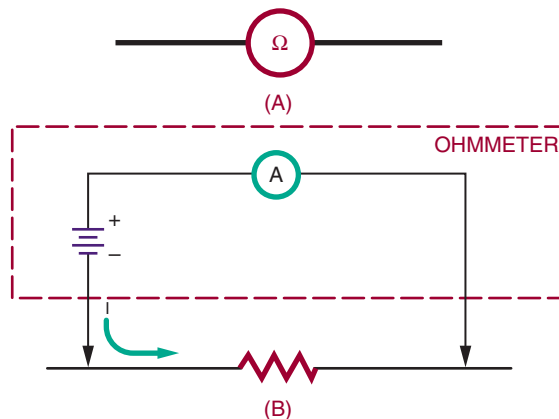


FIGURE 6-7
(A) Schematic symbol for an ohmmeter. (B) An ohmmeter applies a voltage across the component being measured and monitors the current flowing through it.



6-2 QUESTIONS

1. What is used to measure current?
2. What is used to measure voltage?
3. What meter is used to measure resistance?
4. Describe how to measure current with an ammeter.

5. Describe how to measure voltage with a voltmeter.
6. Describe how to measure resistance with an ohmmeter.

6-3 MULTIMETERS

When working on a piece of equipment, many different measurements must be taken. To eliminate the need for several meters, the voltmeter, ammeter, and ohmmeter can be combined into a single instrument called a **multimeter**. An analog multimeter is referred to as a *volt-ohm-milliammeter (VOM)*, Figure 6-8. A digital multimeter is also referred to as a DMM.

The meter in Figure 6-8 has five voltage positions, four current positions, and three resistance positions. There are five scales on the meter to accommodate the various ranges and functions. The technician selects the switch on the multimeter for the desired voltage, current, or resistance range. The zero ohm control adjusts the ohmmeter circuit to compensate for variations in the voltage of the internal batteries. The function switch has three positions: -DC, +DC, and AC. To measure current, DC voltage, and resistance, the function switch is placed at -DC or +DC according to the polarity of the applied current or voltage. The function switch permits reversal of the test lead connections without removing the leads from the circuit being tested.

To measure DC voltage, set the function switch to +DC. With the function switch set at +DC, the common jack is negative and the plus jack is positive. The voltmeter is connected in parallel with the circuit. When measuring an unknown voltage, always set the meter to the highest range (500 volts). If the measured voltage is lower, a lower position can be selected. This procedure protects the meter from damage. Read the voltage on the scale marked

FIGURE 6-8
Analog multimeter.



DC. For the 2.5-volt range, use the 0–250 scale and divide by 100. For the 10-volt, 50-volt, and 250-volt ranges, use the scales directly. For the 500-volt range, use the 0–50 scale and multiply by 10.

To measure current, the selector switch is set for the desired current position and the meter is connected in series with the circuit. The DC scale on the meter is used. For the 1-mA range, use the 0–10 scale and divide by 10. For the 10-mA range, use the 0–10 scale directly. For the 100-mA range, use the 0–10 scale and multiply by 10. For the 500-mA range, use the 0–50 scale and multiply by 10.

To measure resistance, set the selector switch to the desired resistance range. Short the test leads to-

gether. Rotate the zero ohm control until the pointer indicates zero ohms. Separate the test leads and connect them across the component being measured. For measuring resistance between 0 and 200 ohms, use the $R \times 1$ range. To measure resistance between 200 and 20,000 ohms, use the $R \times 100$ range. For resistance above 20,000 ohms, use the $R \times 10,000$. When measuring resistance in digital and semiconductor circuits, do not use the $R \times 1$ scale. This scale is energized by a 9-V battery and could damage the circuitry. Observe the reading on the ohm scale at the top of the meter scales. Note that the ohm scale reads from right to left. To determine the actual resistance value, multiply the reading by the factor at the switch position. The letter *K* equals 1000.

To use the other voltage and current jacks located on the multimeter, refer to the operator's manual.

With a DMM, the meter movement is replaced by a digital readout, which is similar to the readout used in an electronic calculator. The difference is the display is typically four digits.

The controls of a DMM are similar to those found on an analog meter. The exception is with a digital meter that has an autoranging feature. It does not need to identify the range of the signal being tested.

The readout of the DMM automatically places the decimal point with the appropriate unit prefix. DC measurements are displayed with a + or - sign. This avoids the necessity of reversing the test leads.

The advantage of DMMs over VOMs include:

- Easier readability, resulting in a higher accuracy with smaller voltage. The results are repeatable with different readers.
- Autoranging capabilities.
- Autozeroing for resistance reading.
- Autolock of a displayed value.

The disadvantages of a DMM include:

- Requirement for batteries or other source of electricity.

- Voltage limitation that if exceeded could seriously damage the meter.
- Inability to measure an instantaneous change in a signal that is faster than the sampling time.

6-3 QUESTIONS

1. What is a multimeter?
2. What is an analog multimeter called?
3. What is a digital multimeter called?
4. Explain how to use the ohmmeter portion of a VOM.
5. What are the advantages of the DMM over the VOM?

6-4 MEASURING CURRENT

To use an ammeter to measure current, the circuit must be opened and the meter inserted into the circuit in series (Figure 6-9).

When placing the ammeter in the circuit, polarity must be observed. The two terminals on an ammeter are marked: red for positive and black for negative (or common) (Figure 6-10).

CAUTION: ALWAYS TURN OFF THE POWER BEFORE YOU CONNECT AN AMMETER TO A CIRCUIT.

The negative terminal must be connected to the more negative point in the circuit, and the

FIGURE 6-9

An ammeter is connected in series in a circuit.

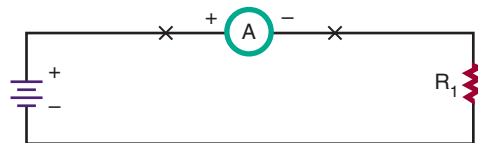


FIGURE 6-10

An ammeter is one part of this VOM. A black negative lead plugs into the common or negative jack. A red positive lead plugs into the jack with the plus symbol.



positive terminal to the more positive point in the circuit (Figure 6-11). When the ammeter is connected, the needle (pointer) of the meter moves from left to right. If the needle moves in the opposite direction, reverse the leads.

Another way to measure current that does not require opening the circuit and placing an ammeter in series is to use a resistor of a known value in the circuit. The resistor is referred to as an *ammeter shunt* and may be installed by the manufacturer or inserted for temporary use. The resistor may be left in for future testing of the circuit and must be of a small enough value to not interfere with the normal operation of the circuit.

FIGURE 6-11

Connect the positive terminal of the ammeter to the more positive point in the circuit. Connect the negative terminal to the more negative point in the circuit.

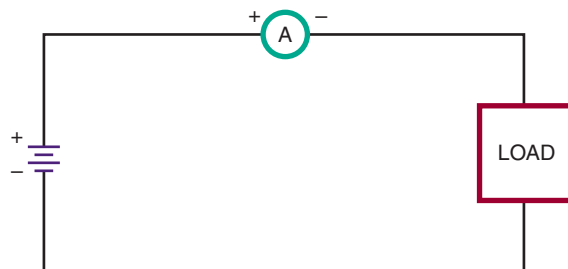
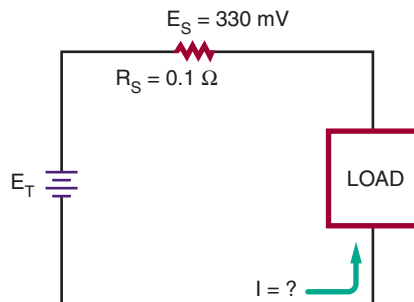


FIGURE 6-12

Determined current through a load.



The resistor's purpose is to provide a small output voltage for measuring. The best meter to use is a DMM because it is able to accurately measure small voltages. Ohm's law ($I = E/R$) is used to calculate the amount of current measured by the shunt. Dividing the voltage read by the resistance value will yield the current flowing in the circuit.

Figure 6-12 shows a 0.1- Ω resistor used as a shunt. If the DMM read 330 mV, then the circuit would have 3.3 A flowing through it.

$$I = \frac{E}{R}$$

$$I = \frac{0.330}{0.1}$$

$$I = 3.3A$$

The advantage of using this technique is that the circuit does not have to be opened and an ammeter inserted. Also note that voltage—rather than current—was read.

CAUTION: AN ANALOG AMMETER MUST NEVER BE CONNECTED IN PARALLEL WITH ANY OF THE CIRCUIT COMPONENTS. IF CONNECTED IN PARALLEL, THE FUSE IN THE AMMETER WILL BLOW AND MAY SERIOUSLY DAMAGE THE METER OR THE CIRCUIT. ALSO, NEVER CONNECT AN AMMETER DIRECTLY TO A VOLTAGE SOURCE.

Before turning on power to the circuit after the ammeter is installed, set the meter to its highest scale (its highest ammeter range prior to applying power). After the power is applied, the ammeter can be set to the appropriate scale. This prevents the needle of the meter movement from being driven into its stop.

The internal resistance of the ammeter adds to the circuit and increases the total resistance of the circuit. Therefore, the measured circuit current can be slightly lower than the actual circuit current. However, because the resistance of an ammeter is usually minute compared to the circuit resistance, the error is ignored.

A clip-on ammeter requires no connection to the circuit being measured and uses the electromagnetic field created by the current flow to measure the amount of current in the circuit.

6-4 QUESTIONS

1. How is an ammeter connected to a circuit?
2. What is the first step prior to connecting an ammeter in a circuit?
3. What should be done if the ammeter reads in the reverse direction?
4. What scale should the ammeter be placed on prior to applying power?

6-5 MEASURING VOLTAGE

Voltage exists between two points; it does not flow through a circuit as current does. Therefore, a voltmeter, used to measure voltage, is connected in parallel with the circuit.

CAUTION: IF AN ANALOG VOLTMETER IS CONNECTED IN SERIES WITH A CIRCUIT, A LARGE CURRENT CAN FLOW THROUGH THE METER AND MIGHT DAMAGE IT.

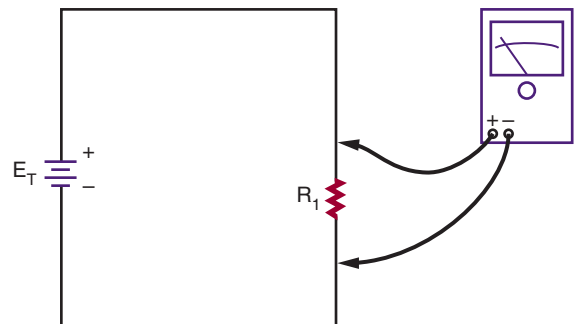
Polarity is important. The negative terminal of the voltmeter must be connected to the more negative point in the circuit, and the positive terminal to the more positive point in the circuit (Figure 6-13). If the connections are reversed, the pointer deflects toward the left side of the meter, registering no measurement. If this occurs, reverse the meter leads.

A good practice is to remove power from the circuit, connect the voltmeter, and then reapply power. Initially, set the voltmeter for its highest scale. After the voltage is applied to the circuit, set the meter down to the proper scale.

The voltmeter's internal resistance is connected in parallel with the component being measured. The total resistance of resistors in parallel is always

FIGURE 6-13

When connecting a voltmeter into a circuit, be sure to observe polarity.



less than that of the smallest resistor. As a result, the voltage read by the voltmeter is smaller than the actual voltage across the component. In most cases, the internal resistance of a voltmeter is high, so that the error is small and can be ignored. However, if voltage is being measured in a high-resistance circuit, meter resistance may have a noticeable effect. Some voltmeters are designed with extra-high internal resistance for such purposes.

Currently, the DMM is the best all-around meter available. The voltage ranges have very little loading effect on the circuits being measured. The meter's internal resistance is typically up to 10 M Ω on its voltage range compared to a quality analog meter with an internal resistance of 20,000 Ω/V , which would yield 20,000 Ω on its 1-V range.

6-5 QUESTIONS

1. How is a voltmeter connected to a circuit?
2. What is the recommended practice for connecting a voltmeter to a circuit?
3. What should be done if the voltmeter reads in the reverse direction?
4. What caution must be taken when measuring a high-resistance circuit?

6-6 MEASURING RESISTANCE

An ohmmeter measures the resistance of a circuit or component by applying a known voltage. The voltage is supplied by batteries. When a constant voltage is applied to the meter circuit through the component under test, the pointer is deflected based on the current flow. The meter deflection varies with the resistance being measured. To measure the resistance of a circuit or component, the ohmmeter is connected in parallel with the circuit or component.

CAUTION: PRIOR TO CONNECTING AN OHMMETER TO A CIRCUIT, MAKE SURE THE POWER IS TURNED OFF.

When measuring a component in a circuit, disconnect one end of the component from the circuit. This eliminates parallel paths, which result in an incorrect resistance reading. The device must be removed from the circuit to obtain an accurate reading. Then, the ohmmeter leads are connected across the device (Figure 6-14).

Because the primary purpose of an ohmmeter is to measure resistance, it can be used in determining whether a circuit is open, shorted, or closed. An **open circuit** has infinite resistance because no current flows through it (Figure 6-15). A **short circuit** has zero ohms of resistance because current flows through it without developing a voltage drop. A **closed circuit** is a complete path for current flow. Its resistance varies depending on the components in the circuit (Figure 6-16).

The testing for an open, short, or closed circuit is called a **continuity test** or check. It is a check

FIGURE 6-14

When using an ohmmeter to measure resistance, the component being measured must be removed from the circuit.

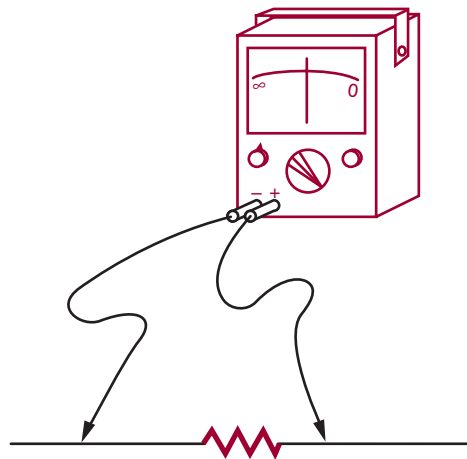
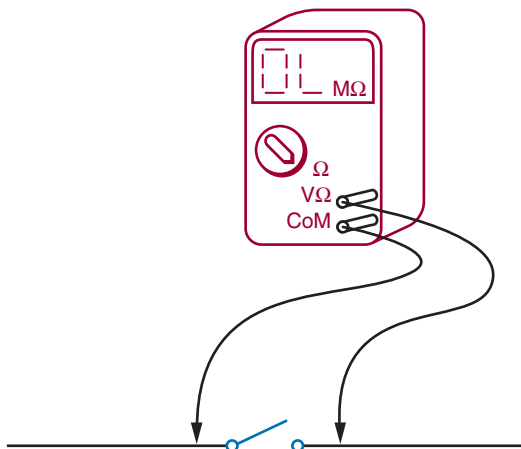
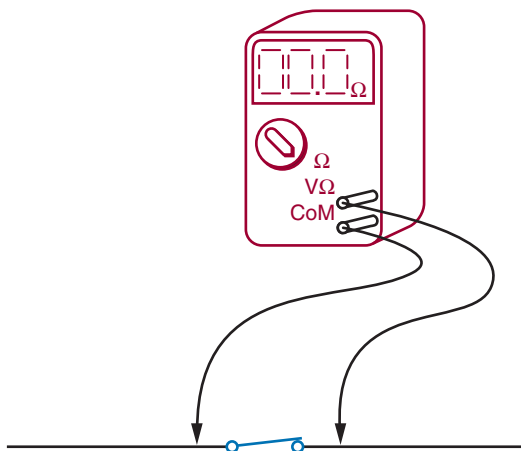


FIGURE 6–15

An ohmmeter can be used to determine whether a circuit is open. An open circuit indicates a high resistance.

**FIGURE 6–16**

An ohmmeter can also be used to determine whether a circuit offers a complete path for current flow. A closed circuit indicates a low resistance.



to determine if a current path is continuous. To determine whether a circuit is open or closed, the lowest scale on the ohmmeter should be used. First ensure that there are no components in the circuit that may be damaged by the current flow

from the ohmmeter. Then place the leads of the ohmmeter across the points in the circuit to be measured. If a reading occurs, the path is closed or shorted. If no reading occurs, the path is open. This test is useful to determine why a circuit does not work.

The DMM has several advantages over the analog multimeter, including higher accuracy, digital readout, and repeatability of the reading. Unlike the VOM, the DMM uses very little current to test resistances. This allows the testing of semiconductor junctions. In fact, many DMMs have a special range for testing semiconductor junctions. These meters use approximately 1 mA of current through the junction under test.

Another feature of a DMM is an audio signal or “beeper” for continuity testing. This allows the operator to focus on the circuit rather than on the meter for continuity testing. The use of the beeper function is not to check for resistance but rather for continuity.

NOTE: WHEN USING ANY METER, IT IS IMPORTANT TO KEEP FINGERS FROM TOUCHING THE PROBES TO AVOID PUTTING BODY RESISTANCE IN PARALLEL WITH THE COMPONENT UNDER TEST, THEREBY INTRODUCING ERRORS.

6–6 QUESTIONS

1. How does an ohmmeter work?
2. What caution must be observed prior to connecting an ohmmeter to a circuit?
3. What is the primary purpose of an ohmmeter?
4. For what other purpose may an ohmmeter be used?
5. Why is a DMM better for testing semiconductors than a VOM?
6. Why is a DMM better for continuity testing than a VOM?

6-7 READING METER SCALES

Voltmeter and ammeter scales are read in the same manner. However, voltmeters measure volts and ammeters measure amperes.

The maximum value indicated by a meter is called the **full scale value**. In other words, the maximum voltage or current that a meter can read is its full scale value.

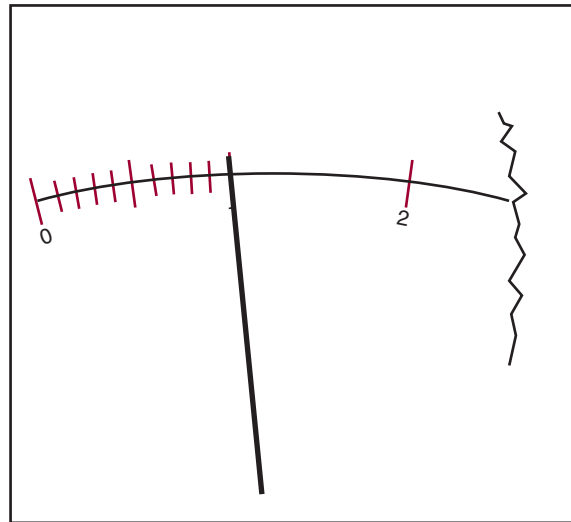
The measured value of voltage or current is read on the scale under the pointer. For example, the pointer in Figure 6-17 is shown deflected one major division, indicating a voltage of 1 volt or a current of 1 ampere. In Figure 6-18, the meter is shown deflected seven major divisions, indicating a current of 7 amperes or a voltage of 7 volts.

If the pointer of the meter rests between the major divisions of the scale, the smaller divisions are read. Figure 6-19 shows four small lines between each major division of the scale, creating five equally spaced intervals. Each of these small intervals represents one-fifth of the major interval, or 0.2 unit.

If the pointer falls between the small lines on a meter scale, the value must be estimated. In Figure 6-20 the pointer falls between the $\frac{2}{5}$ (0.4)

FIGURE 6-17

The reading indicates 1 volt or ampere.



and $\frac{3}{5}$ (0.6) marks. This indicates a value of approximately 2.5 volts or amperes. In Figure 6-21, the pointer is one-fourth of the distance between the $\frac{3}{5}$ (0.6) and $\frac{4}{5}$ (0.8) marks. Each small interval represents 0.2. One-fourth of 0.2 is 0.05. Therefore, the pointer indicates a value of about 4.65 volts or amperes.

FIGURE 6-18

The reading indicates 7 volts or amperes.

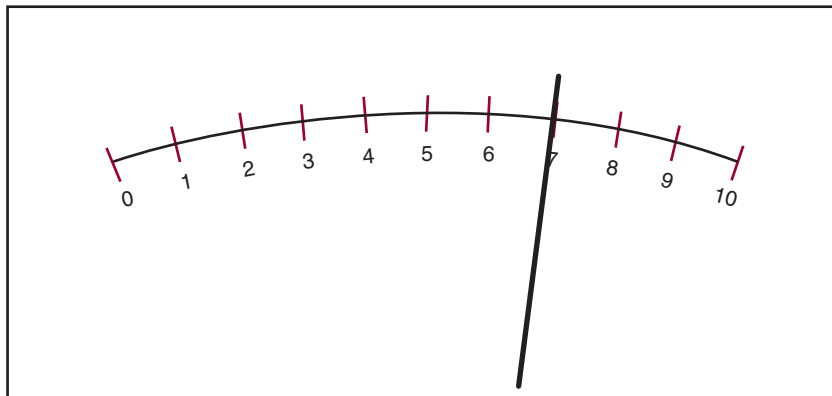
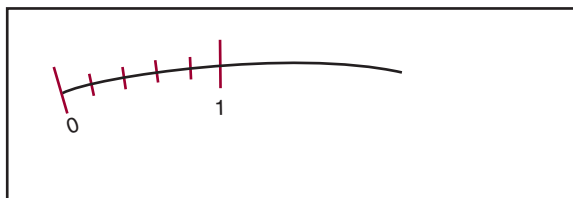
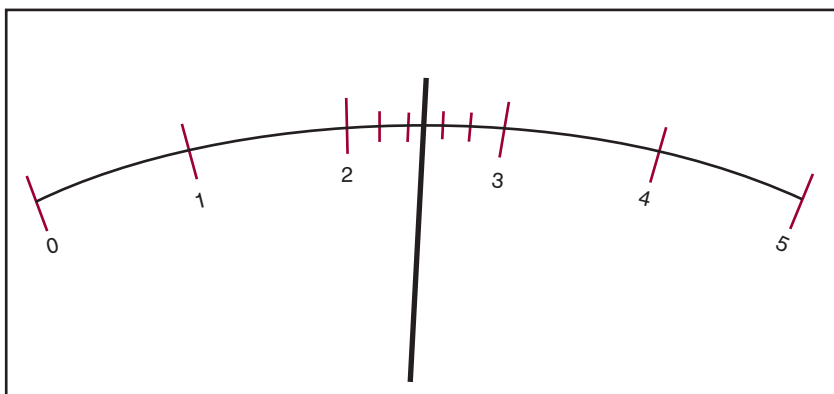


FIGURE 6-19

Each small division represents 0.2 volt or ampere.

**FIGURE 6-20**

The reading indicates 2.5 volts or amperes.

**FIGURE 6-21**

The reading indicates 4.65 volts or amperes.

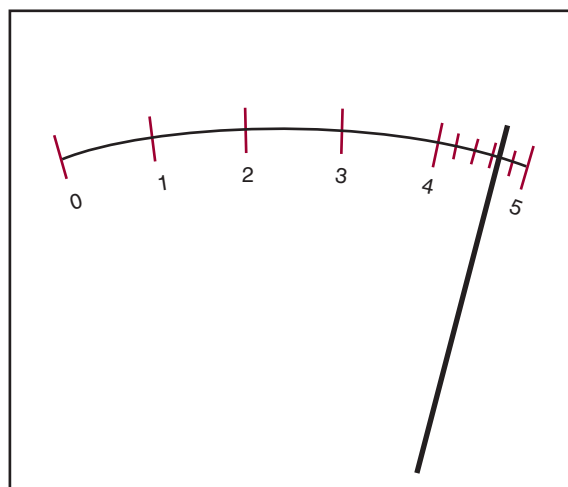
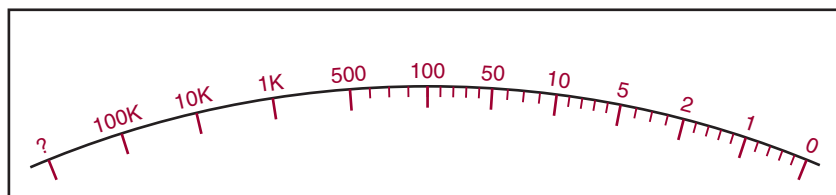


FIGURE 6–22

The ohmmeter scale is read from right to left.



The number of major and minor divisions on a meter scale depends on the range of the voltage or current that the meter is designed to measure. In all cases, the value of the small intervals can be found by dividing the value of the major interval by the number of spaces it contains.

The ohm scale on a meter is different from most voltage and current scales (Figure 6–22). It is read from right to left instead of from left to right. Also, it is a nonlinear scale, so the number of small spaces between the major intervals is not the same throughout the scale. Between 0 and 1 there are five small spaces, which equal 0.2 unit each. There are four intervals between 5 and 10, representing 1 unit each, and between each of these there is a minor division that represents 0.5 unit. Between the 50 and 100 marks are five small intervals, which each represent 10 units. Between 100 and 500 there are four small intervals, each representing 100 units. The last mark on the left is labeled infinity (∞). If the pointer deflects to this mark, the resistance is beyond the range of the meter. The pointer normally rests on the infinity mark when no resistance is being measured. Figure 6–23 shows the pointer deflected to 1.5 ohms. Figure 6–24 shows the pointer indicating 200 ohms.

Prior to using an ohmmeter, the test leads are shorted together and the zero control is adjusted so the pointer rests on the zero mark. This calibrates the meter and compensates for battery deterioration.

6–7 QUESTIONS

1. What determines the maximum value an analog meter can measure?
2. What are the differences between an ohmmeter scale and a voltmeter or ammeter scale?
3. Estimate the reading of the voltmeter scales in Figure 6–25.

SUMMARY

- Analog meters use a graduated scale with a pointer.
- Digital meters provide a direct readout.
- On both analog and digital meters, the red terminal is positive and the black terminal is negative.
- Before using an analog meter, check the mechanical zero adjustment.
- A multimeter combines a voltmeter, ammeter, and ohmmeter into one package.
- A VOM is an analog multimeter that measures volts, ohms, and milliamperes.
- A DMM is a digital multimeter.
- On a multimeter, the range selector switch selects the function to be used.
- An ammeter must be connected in series with a circuit.
- A voltmeter is connected in parallel with a circuit.

FIGURE 6–23

The reading indicates 1.5 ohms.

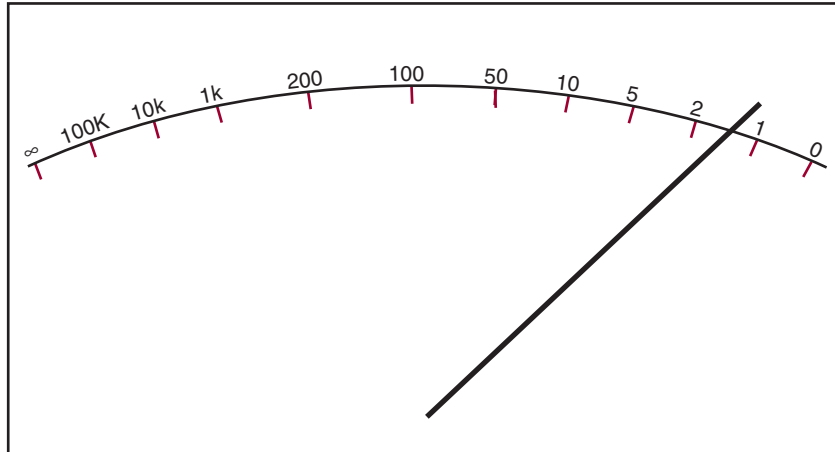
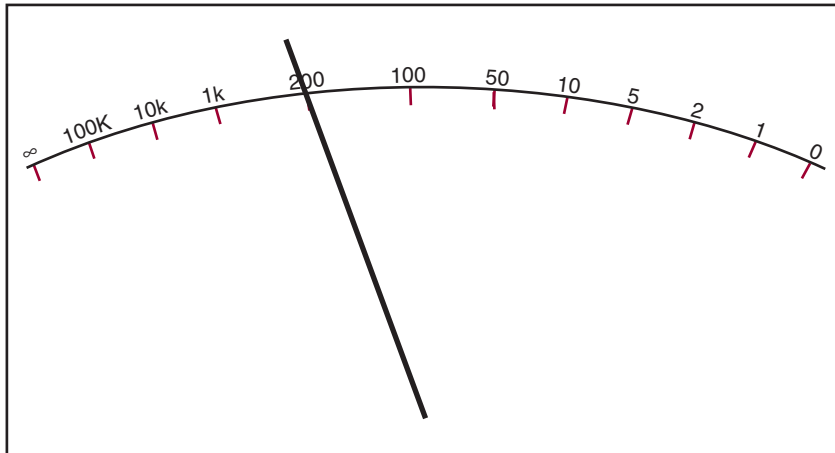


FIGURE 6–24

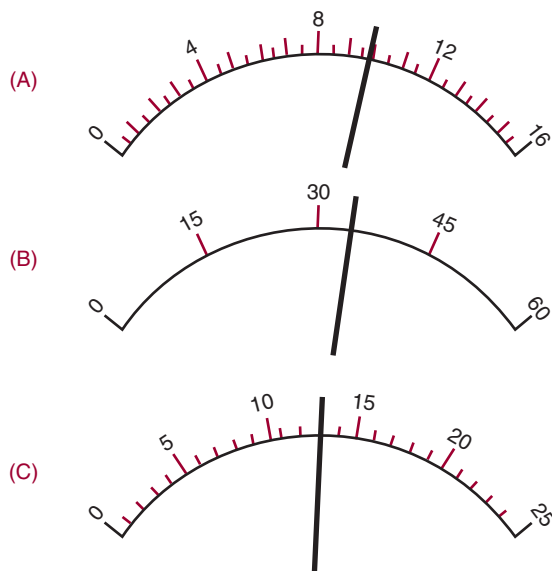
The reading indicates 200 ohms.



- An ohmmeter measures resistance by the amount of current flowing through the resistor being measured.
- The maximum value of a meter scale is called the full scale value.
- The number of divisions on the meter scale depends on the range the meter is designed to measure.
- Ammeters and voltmeters are read from left to right and have a linear scale.
- Ohmmeters are read from right to left and have nonlinear scales.
- An analog ohmmeter must be calibrated before use to compensate for battery deterioration.

FIGURE 6-25

Analog multimeter.



CHAPTER 6 SELF-TEST

- Which type of meter, analog or digital, would you use for an accurate reading?
- Which type of meter, analog or digital, would you use to gauge rapid changes in a source?
- Draw a meter scale for each of the following and show where the needle would point for the following readings.
 - 23 V
 - 220 mA
 - 2700 ohms
- What are the advantages of using a multimeter?

Power

OBJECTIVES

After completing this chapter, the student should be able to:

- Define *power* as it relates to electric circuits.
- State the relationship of current and voltage.
- Solve for power consumption in an electrical circuit.
- Determine the total power consumption in a series, parallel, or series-parallel circuit.



See accompanying CD for interactive presentations, tutorials and Power examples in MultiSim, Chapter 7.

In addition to current, voltage, and resistance, a fourth quantity is important in circuit analysis. This quantity is called power.

Power is the rate at which work is done. Power is expended every time a circuit is energized. Power is directly proportional to both current and voltage.

This chapter looks at circuit applications involving power.

7-1 POWER

Electrical or mechanical power relates to the rate at which work is being done. Work is done whenever a force causes motion. If a mechanical force is used to lift or move a weight, work is being done. However, force exerted without caus-

ing motion, such as a force of a compressed spring between two fixed objects, does not constitute work.

Voltage is an electrical force that creates current flow in a closed circuit. When voltage exists between two points and current cannot flow, no work is done. This is similar to a spring under tension that produces no motion. When voltage causes electrons to move in a circuit, work is being done. The instantaneous rate at which work is done is called the *electric power rate* and is measured in watts. **Power** can be defined at the rate which energy is dissipated in a circuit.

The total amount of work done may be accomplished in different lengths of time. For example, a given quantity of electrons may be moved from one location to another in one second, one minute, or one hour, depending on the

rate in which they were moved. In all cases, the total amount of work done is the same. However, when the work is done in a short period of time, the instantaneous power rate (wattage) is greater than when the same amount of work is done over a longer period of time.

As mentioned, the basic unit of power is the **watt**. A watt is equal to the voltage across a circuit multiplied by the current through the circuit. It represents the rate at any given instant in which work is being done, moving electrons through the circuit. The symbol P represents electrical power. The relationship of power, current, and voltage may be expressed as follows:

$$P = I \times E$$

I represents the current through the circuit and E represents the voltage applied to the circuit being measured. The amount of power will differ with any change in the voltage or current in the circuit.

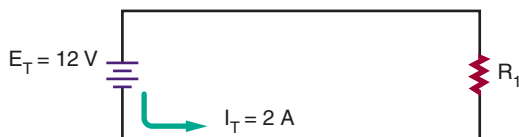
EXAMPLE: Calculate the power consumed in the circuit shown in Figure 7-1.

Given:	Solution:
$P = ?$	$P = IE$
$I = 2$ amps	$P = (2)(12)$
$E = 12$ volts	$P = 24$ watts

EXAMPLE: What voltage is required to deliver 2 amperes of current at 200 watts?

Given:	Solution:
$P = 200$ watts	$P = IE$
$I = 2$ amps	$200 = 2(E)$
$E = ?$	$100 \text{ volts} = E$

FIGURE 7-1



EXAMPLE: How much current does a 100-watt, 120-volt light bulb use?

Given:	$P = 100$ watts
	$I = ?$
	$E = 120$ volts

Solution:	$P = IE$
	$100 = (I)(120)$
	$0.83 \text{ amp} = I$

7-1 QUESTIONS

1. Define *power* as it relates to electricity.
2. What unit is used to measure power?
3. Calculate the missing value:
 - a. $P = ?$, $E = 12 \text{ V}$, $I = 1 \text{ A}$
 - b. $P = 1000 \text{ W}$, $E = ?$, $I = 10 \text{ A}$
 - c. $P = 150 \text{ W}$, $E = 120 \text{ V}$, $I = ?$

7-2 POWER APPLICATION (CIRCUIT ANALYSIS)

Resistive components in a circuit consume power. To determine the power dissipated by a component, multiply the voltage drop across the component by the current flowing through the component.

$$P = IE$$

The total power dissipated in a series or parallel circuit is equal to the sum of the power dissipated by the individual components. This can be expressed as:

$$P_T = P_{R_1} + P_{R_2} + P_{R_3} \dots + P_{R_n}$$

The power dissipated in a circuit is often less than 1 watt. To facilitate the use of these smaller numbers, the milliwatt (mW) and the microwatt (μW) are used.

1000 milliwatts = 1 watt

$$1 \text{ milliwatt} = \frac{1}{1000} \text{ watt}$$

1,000,000 microwatts = 1 watt

$$1 \text{ microwatt} = \frac{1}{1,000,000} \text{ watt}$$

EXAMPLE: How much power is consumed in the circuit shown in Figure 7-2?

First determine the total resistance for the circuit.

Given:	Solution:
$R_T = ?$	$R_T = R_1 + R_2 + R_3$
$R_1 = 560 \text{ ohms}$	$R_T = 560 + 820 + 1000$
$R_2 = 820 \text{ ohms}$	$R_T = 2380 \text{ ohms}$
$R_3 = 1000 \text{ ohms}$	

Now determine the total current flowing in the circuit, using Ohm's law.

Given:

$$I_T = ?$$

$$E_T = 12 \text{ volts}$$

$$R_T = 2380 \text{ ohms}$$

Solution:

$$I_T = \frac{E_T}{R_T}$$

$$I_T = \frac{12}{2380}$$

$$I_T = 0.005 \text{ amp}$$

The total power consumption can now be determined using the power formula.

Given:	Solution:
$P_T = ?$	$P_T = I_T E_T$
$I_T = 0.005 \text{ amp}$	$P_T = (0.005)(12)$
$E_T = 12 \text{ volts}$	$P_T = 0.06 \text{ watt or } 60 \text{ mW}$

EXAMPLE: What is the value of resistor R_2 in the circuit shown in Figure 7-3?

First determine the voltage drop across resistor R_1 . In a parallel circuit the voltage is the same in all branches.

Given:

$$P_{R_1} = 0.018 \text{ watt}$$

$$I_{R_1} = 0.0015 \text{ amp}$$

$$E_{R_1} = ?$$

Solution:

$$P_{R_1} = I_{R_1} E_{R_1}$$

$$0.018 = (0.0015)(E_{R_1})$$

$$E_{R_1} = 12 \text{ volts}$$

FIGURE 7-2

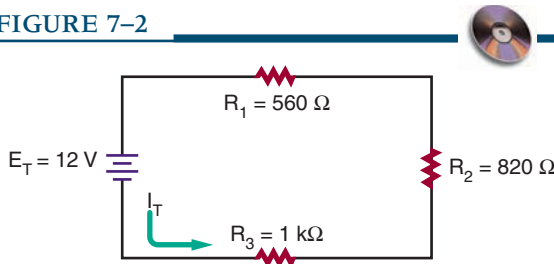
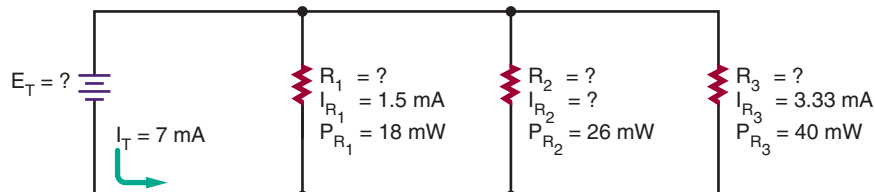


FIGURE 7-3



Now the current through resistor R_2 can be determined.

Given:

$$P_{R_2} = 0.026 \text{ watt}$$

$$I_{R_2} = ?$$

$$E_{R_2} = 12 \text{ volts}$$

Solution:

$$P_{R_2} = I_{R_2} E_{R_2}$$

$$0.026 = (I_{R_2})(12)$$

$$I_{R_2} = 0.00217 \text{ amp}$$

The resistance value of R_2 can now be determined using Ohm's law.

Given:

$$I_{R_2} = 0.00217 \text{ amp}$$

$$E_{R_2} = 12 \text{ volts}$$

$$R_2 = ?$$

Solution:

$$I_{R_2} = \frac{E_{R_2}}{R_2}$$

$$0.00217 = \frac{12}{R_2}$$

$$R_2 = 5530 \text{ ohms}$$

EXAMPLE: If a current of 0.05 ampere flows through a 22-ohm resistor, how much power is dissipated by the resistor?

The voltage drop across the resistor must first be determined using Ohm's law.

Given:

$$I_R = 0.05 \text{ amp}$$

$$E_R = ?$$

$$R = 22 \text{ ohms}$$

Solution:

$$I_R = \frac{E_R}{R}$$

$$0.05 = \frac{E_R}{22}$$

$$E_R = 1.1 \text{ volts}$$

The power consumed by the resistor can now be determined using the power formula.

Given:

$$P_R = ?$$

$$E_R = 1.1 \text{ volts}$$

$$I_R = 0.05 \text{ amp}$$

Solution:

$$P_R = I_R E_R$$

$$P_R = (0.05)(1.1)$$

$$P_R = 0.055 \text{ watt or } 55 \text{ mW}$$

7-2 QUESTIONS

1. What is the formula for power when both the current and voltage are known?
2. What is the formula for determining the total power in a series circuit? A parallel circuit?
3. Convert the following:
 - a. 100 mW = _____ μ W
 - b. 10 W = _____ mW
 - c. 10 μ W = _____ W
 - d. 1000 μ W = _____ mW
 - e. 0.025 W = _____ mW
4. What is the power consumed by each resistor in the circuit shown in Figure 7-4?
5. What is the power consumed by each resistor in the circuit shown in Figure 7-5?
6. What is the power consumed by each resistor in the circuit shown in Figure 7-6?

FIGURE 7-4

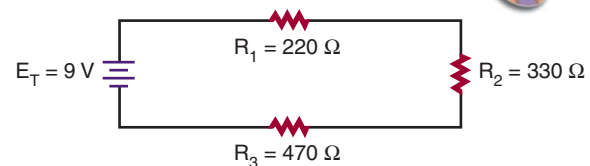


FIGURE 7-5

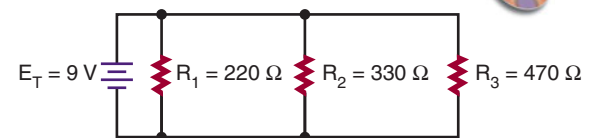
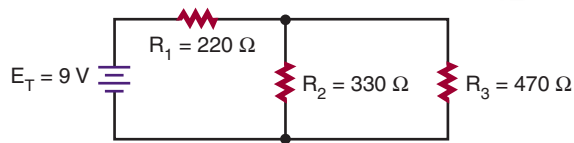


FIGURE 7-6



SUMMARY

- Power is the rate at which energy is delivered to a circuit.

- Power is also the rate at which energy (heat) is dissipated by the resistance in a circuit.
- Power is measured in watts.
- Power is the product of current and voltage:

$$P = IE$$

- The total power dissipated in a series or parallel circuit is equal to the sum of the power dissipated by the individual components.

$$P_T = P_1 + P_2 + P_3 \dots + P_n$$

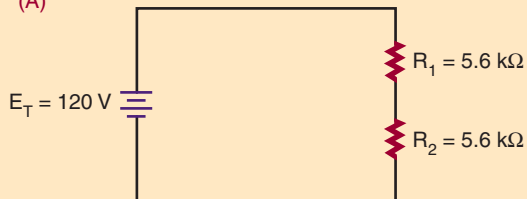
CHAPTER 7 SELF-TEST

Using Watt's law, find the missing value for the following:

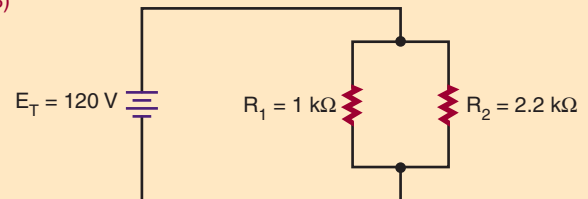
1. $P = ?$ $E = 30 \text{ V}$ $I = 40 \text{ mA}$
2. $P = 1 \text{ W}$ $E = ?$ $I = 10 \text{ mA}$
3. $P = 12.3 \text{ W}$ $E = 30 \text{ V}$ $I = ?$

4. What is the total power consumption for the following circuits?

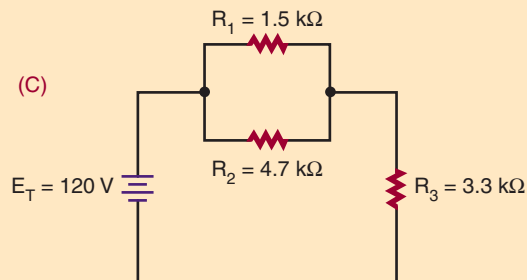
(A)



(B)



(C)



DC Circuits

OBJECTIVES

After completing this chapter, the student should be able to:

- Solve for all unknown values (current, voltage, resistance, and power) in a series, parallel, or series-parallel circuit.
- Understand the importance of voltage dividers.
- Design and solve for all unknown values in a voltage-divider circuit.



See accompanying CD for interactive presentations, tutorials, and DC Circuit examples in MultiSim, Chapter 8.

In the study of electronics, certain circuits appear again and again. The most commonly used circuits are the series circuit, the parallel circuit, and the series-parallel circuit.

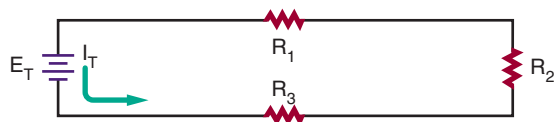
This chapter applies information from the last few chapters to the solving of all unknowns in these three basic types of circuits. Voltage dividers can make available several voltages from a single voltage source. Voltage dividers are essentially series circuits with parallel loads. This chapter helps the student understand how significant voltage dividers are as an application of series circuits and how to design one for a specific application.

8-1 SERIES CIRCUITS

A series circuit (Figure 8-1) provides only one path for current flow. The factors governing the operation of a series circuit are:

FIGURE 8-1

Series circuit.



1. The same current flows through each component in a series circuit.

$$I_T = I_{R_1} = I_{R_2} = I_{R_3} \dots = I_{R_N}$$

2. The total resistance in a series circuit is equal to the sum of the individual resistances.

$$R_T = R_1 + R_2 + R_3 \dots + R_N$$

3. The total voltage across a series circuit is equal to the sum of the individual voltage drops.

$$E_T = E_{R_1} = E_{R_2} = E_{R_3} \dots = E_{R_N}$$

- The voltage drop across a resistor in a series circuit is proportional to the size of the resistor. ($I = E/R$)
- The total power dissipated in a series circuit is equal to the sum of the individual power dissipations.

$$P_T = P_{R_1} + P_{R_2} + P_{R_3} \dots + P_{R_N}$$

EXAMPLE: Three resistors, 47 ohms, 100 ohms, and 150 ohms, are connected in series with a battery rated at 12 volts. Solve for all values in the circuit.

The first step is to draw a schematic of the circuit and list all known variables. See Figure 8–2.

Given:

$I_T = ?$	$R_1 = 47 \text{ ohms}$	$E_{R_1} = ?$
$E_T = 12 \text{ volts}$	$R_2 = 100 \text{ ohms}$	$E_{R_2} = ?$
$R_T = ?$	$R_3 = 150 \text{ ohms}$	$E_{R_3} = ?$
$P_T = ?$		$P_{R_1} = ?$
		$P_{R_2} = ?$
		$P_{R_3} = ?$

In solving for all values in a circuit, the total resistance must be found first. Then the total circuit current can be determined. Once the current is known, the voltage drops and power dissipation can be determined.

Given:

$R_T = ?$	Solution:
$R_1 = 47 \text{ ohms}$	$R_T = R_1 + R_2 + R_3$
$R_2 = 100 \text{ ohms}$	$R_T = 47 + 100 + 150$
$R_3 = 150 \text{ ohms}$	$R_T = 297 \text{ ohms}$

Using Ohm's law, the current is:

Given:

$$I_T = ?$$

$$E_T = 12 \text{ volts}$$

$$R_T = 297 \text{ ohms}$$

Since $I_T = I_{R_1} = I_{R_2} = I_{R_3}$, the voltage drop (E_{R_1}) across resistor R_1 is:

Given:

$$I_{R_1} = 0.040 \text{ amp}$$

$$E_{R_1} = ?$$

$$R_1 = 47 \text{ ohms}$$

The voltage drop (E_{R_2}) across resistor R_2 is:

Given:

$$I_{R_2} = 0.040 \text{ amp}$$

$$E_{R_2} = ?$$

$$R_2 = 100 \text{ ohms}$$

The voltage drop (E_{R_3}) across resistor R_3 is:

Given:

$$I_{R_3} = 0.040 \text{ amp}$$

$$E_{R_3} = ?$$

$$R_3 = 150 \text{ ohms}$$

Verify that the sum of the individual voltages is equal to the total voltage.

Given:

$$E_T = 12 \text{ volts}$$

$$E_{R_1} = 1.88 \text{ volts}$$

$$E_{R_2} = 4 \text{ volts}$$

$$E_{R_3} = 6 \text{ volts}$$

Solution:

$$I_T = \frac{E_T}{R_T}$$

$$I_T = \frac{12}{297}$$

$$I_T = 0.040 \text{ amp}$$

Solution:

$$I_{R_1} = \frac{E_{R_1}}{R_1}$$

$$0.040 = \frac{E_{R_1}}{47}$$

$$E_{R_1} = 1.88 \text{ volts}$$

Solution:

$$I_{R_2} = \frac{E_{R_2}}{R_2}$$

$$0.040 = \frac{E_{R_2}}{100}$$

$$E_{R_2} = 4 \text{ volts}$$

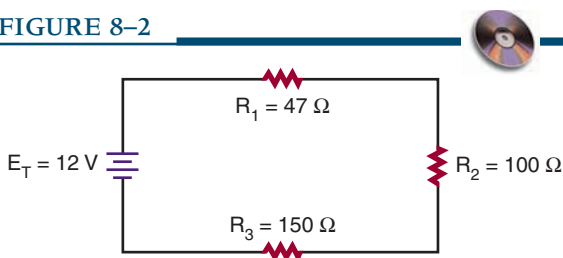
Solution:

$$I_{R_3} = \frac{E_{R_3}}{R_3}$$

$$0.040 = \frac{E_{R_3}}{150}$$

$$E_{R_3} = 6 \text{ volts}$$

FIGURE 8–2



There is a difference between the calculated and the total given voltage due to the rounding of the total current to three decimal places.

The power dissipated across resistor R_1 is:

Given:

$$P_{R_1} = ?$$

$$I_{R_1} = 0.040 \text{ amp}$$

$$E_{R_1} = 1.88 \text{ volts}$$

Solution:

$$P_{R_1} = I_{R_1} E_{R_1}$$

$$P_{R_1} = (0.040)(1.88)$$

$$P_{R_1} = 0.075 \text{ watt}$$

The power dissipated across resistor R_2 is:

Given:

$$P_{R_2} = ?$$

$$I_{R_2} = 0.040 \text{ amp}$$

$$E_{R_2} = 4 \text{ volts}$$

Solution:

$$P_{R_2} = I_{R_2} E_{R_2}$$

$$P_{R_2} = (0.040)(4)$$

$$P_{R_2} = 0.16 \text{ watt}$$

The power dissipated across resistor R_3 is:

Given:

$$P_{R_3} = ?$$

$$I_{R_3} = 0.040 \text{ amp}$$

$$E_{R_3} = 6 \text{ volts}$$

Solution:

$$P_{R_3} = I_{R_3} E_{R_3}$$

$$P_{R_3} = (0.040)(6)$$

$$P_{R_3} = 0.24 \text{ watt}$$

The total power dissipated is:

Given:

$$P_T = ?$$

$$P_{R_1} = 0.075 \text{ watt}$$

$$P_{R_2} = 0.16 \text{ watt}$$

$$P_{R_3} = 0.24 \text{ watt}$$

Solution:

$$P_T = P_{R_1} + P_{R_2} + P_{R_3}$$

$$P_T = 0.075 + 0.16 + 0.24$$

$$P_T = 0.475 \text{ watt or } 475 \text{ mW}$$

8-1 QUESTION

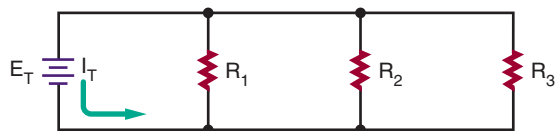
- Four resistors, 270 ohms, 560 ohms, 1200 ohms, and 1500 ohms, are connected in series with a battery rated at 28 volts. Solve for all values of the circuit.

8-2 PARALLEL CIRCUITS

A *parallel circuit* (Figure 8-3) is defined as a circuit having more than one current path. The factors governing the operations of a parallel circuit are:

FIGURE 8-3

Parallel circuit.



- The same voltage exists across each branch of the parallel circuit and is equal to that of the voltage source.

$$E_T = E_{R_1} = E_{R_2} = E_{R_3} \dots = E_{R_n}$$

- The current through each branch of a parallel circuit is inversely proportional to the amount of resistance of the branch, ($I = E/R$).
- The total current in a parallel circuit is the sum of the individual branch currents.

$$I_T = I_{R_1} + I_{R_2} + I_{R_3} \dots + I_{R_n}$$

- The reciprocal of the total resistance in a parallel circuit is equal to the sum of the reciprocals of the individual resistances.

$$\frac{1}{R_T} = \frac{1}{R_1} + \frac{1}{R_2} + \frac{1}{R_3} \dots + \frac{1}{R_n}$$

- The total power consumed in a parallel circuit is equal to the sum of the power consumed by the individual resistors.

$$P_T = P_{R_1} + P_{R_2} + P_{R_3} \dots + P_{R_n}$$

EXAMPLE: Three resistors, 100 ohms, 220 ohms, and 470 ohms, are connected in parallel with a battery rated at 48 volts. Solve for all values of the circuit.

First draw a schematic of the circuit and list all known variables (Figure 8-4).

Given:

$$I_T = ?$$

$$E_T = 48 \text{ volts}$$

$$R_T = ?$$

$$P_T = ?$$

$$R_1 = 100 \text{ ohms}$$

$$R_2 = 220 \text{ ohms}$$

$$R_3 = 470 \text{ ohms}$$

$$I_{R_1} = ?$$

$$I_{R_2} = ?$$

$$I_{R_3} = ?$$

$$P_{R_1} = ?$$

$$P_{R_2} = ?$$

$$P_{R_3} = ?$$

In solving the circuit for all values, the total resistance must be found first. Then the individual currents flowing through each branch of the circuit can be found. Once the current is known, the power dissipation across each resistor can be determined.

Given:

$$\begin{aligned}R_T &= ? \\R_1 &= 100 \text{ ohms} \\R_2 &= 220 \text{ ohms} \\R_3 &= 470 \text{ ohms}\end{aligned}$$

Solution:

$$\begin{aligned}\frac{1}{R_T} &= \frac{1}{R_1} + \frac{1}{R_2} + \frac{1}{R_3} \\ \frac{1}{R_T} &= \frac{1}{100} + \frac{1}{220} + \frac{1}{470} \\ R_T &= 59.98 \text{ ohms}\end{aligned}$$

The current (I_{R_1}) through resistor R_1 is:

Given:

$$I_{R_1} = ?$$

$$E_{R_1} = 48 \text{ volts}$$

$$R_1 = 100 \text{ ohms}$$

Solution:

$$I_{R_1} = \frac{E_{R_1}}{R_1}$$

$$I_{R_1} = \frac{48}{100}$$

$$I_{R_1} = 0.48 \text{ amp}$$

The current (I_{R_2}) through resistor R_2 is:

Given:

$$I_{R_2} = ?$$

$$E_{R_2} = 48 \text{ volts}$$

$$R_2 = 220 \text{ ohms}$$

Solution:

$$I_{R_2} = \frac{E_{R_2}}{R_2}$$

$$I_{R_2} = \frac{48}{220}$$

$$I_{R_2} = 0.218 \text{ amp}$$

The current (I_{R_3}) through resistor R_3 is:

Given:

$$I_{R_3} = ?$$

$$E_{R_3} = 48 \text{ volts}$$

$$R_3 = 470 \text{ ohms}$$

Solution:

$$I_{R_3} = \frac{E_{R_3}}{R_3}$$

$$I_{R_3} = \frac{48}{470}$$

$$I_{R_3} = 0.102 \text{ amp}$$

The total current is:

Given:

$$I_T = ?$$

$$I_{R_1} = 0.48 \text{ amp}$$

$$I_{R_2} = 0.218 \text{ amp}$$

$$I_{R_3} = 0.102 \text{ amp}$$

Solution:

$$I_T = I_{R_1} + I_{R_2} + I_{R_3}$$

$$I_T = 0.48 + 0.218 + 0.102$$

$$I_T = 0.800 \text{ amp}$$

The total current can also be found using Ohm's law:

Given:

$$I_T = ?$$

$$E_T = 48 \text{ volts}$$

$$R_T = 59.98 \text{ ohms}$$

Solution:

$$I_T = \frac{E_T}{R_T}$$

$$I_T = \frac{48}{59.98}$$

$$I_T = 0.800 \text{ amps}$$

Again, a difference occurs because of rounding. The power dissipated by resistor R_1 is:

Given:

$$P_{R_1} = ?$$

$$I_{R_1} = 0.48 \text{ amp}$$

$$E_{R_1} = 48 \text{ volts}$$

Solution:

$$P_{R_1} = I_{R_1} E_{R_1}$$

$$P_{R_1} = (0.48)(48)$$

$$P_{R_1} = 23.04 \text{ watts}$$

The power dissipated by resistor R_2 is:

Given:

$$P_{R_2} = ?$$

$$I_{R_2} = 0.218 \text{ amp}$$

$$E_{R_2} = 48 \text{ volts}$$

Solution:

$$P_{R_2} = I_{R_2} E_{R_2}$$

$$P_{R_2} = (0.218)(48)$$

$$P_{R_2} = 10.46 \text{ watts}$$

The power dissipated by resistor R_3 is:

Given:

$$P_{R_3} = ?$$

$$I_{R_3} = 0.102 \text{ amp}$$

$$E_{R_3} = 48 \text{ volts}$$

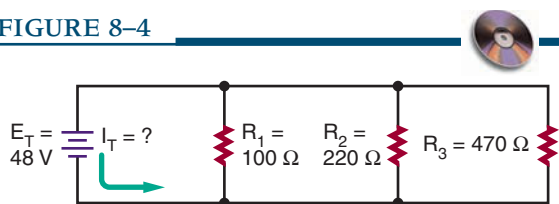
Solution:

$$P_{R_3} = I_{R_3} E_{R_3}$$

$$P_{R_3} = (0.102)(48)$$

$$P_{R_3} = 4.90 \text{ watts}$$

FIGURE 8-4



The total power is:

Given:	Solution:
$P_T = ?$	$P_T = P_{R_1} + P_{R_2} + P_{R_3}$
$P_{R_1} = 23.04$ watts	$P_T = 23.04 + 10.46 + 4.90$
$P_{R_2} = 10.46$ watts	$P_T = 38.40$ watts
$P_{R_3} = 4.90$ watts	

The total power can also be determined using Ohm's law:

Given:	Solution:
$P_T = ?$	$P_T = I_T E_T$
$I_T = 0.80$ amp	$P_T = (0.80)(48)$
$E_T = 48$ volts	$P_T = 38.4$ watts

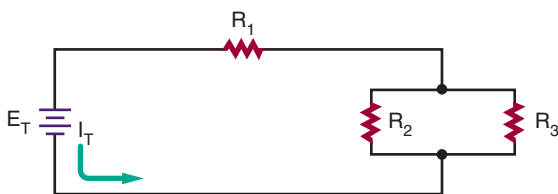
8-2 QUESTION

- Four resistors, 2200 ohms, 2700 ohms, 3300 ohms, and 5600 ohms, are connected in parallel with a battery rated at 9 volts. Solve for all values of the circuit.

8-3 SERIES-PARALLEL CIRCUITS

Most circuits consist of both series and parallel circuits. Circuits of this type are referred to as *series-parallel circuits* (Figure 8-5). The solution of most series-parallel circuits is simply a matter of applying the laws and rules discussed earlier. Series formulas are applied to the series part of the

FIGURE 8-5
Series-parallel circuit.



circuit, and parallel formulas are applied to the parallel parts of the circuit.

EXAMPLE: Solve for all unknown quantities in Figure 8-6. Given:

$$I_T = ?, E_T = 48 \text{ volts}, R_T = ?, P_T = ?$$

$R_1 = 820$ ohms	$I_{R_1} = ?$	$E_{R_1} = ?$	$P_{R_1} = ?$
$R_2 = 330$ ohms	$I_{R_2} = ?$	$E_{R_2} = ?$	$P_{R_2} = ?$
$R_3 = 680$ ohms	$I_{R_3} = ?$	$E_{R_3} = ?$	$P_{R_3} = ?$
$R_4 = 470$ ohms	$I_{R_4} = ?$	$E_{R_4} = ?$	$P_{R_4} = ?$
$R_5 = 120$ ohms	$I_{R_5} = ?$	$E_{R_5} = ?$	$P_{R_5} = ?$
$R_6 = 560$ ohms	$I_{R_6} = ?$	$E_{R_6} = ?$	$P_{R_6} = ?$

To solve for total resistance (R_T), first find the equivalent resistance (R_A) for parallel resistors R_2 and R_3 . Then solve for the equivalent resistance of resistors R_A and R_4 (identified as R_{S_1}) and R_5 and R_6 (identified as R_{S_2}). Then the equivalent resistance ($R_{B_{TS}}$) can be determined for R_{S_1} and R_{S_2} . Finally, find the total series resistance for R_1 and R_B .

Given:

$$\begin{aligned} R_A &= ? \\ R_2 &= 330 \text{ ohms} \\ R_3 &= 680 \text{ ohms} \end{aligned}$$

Solution:

$$\begin{aligned} \frac{1}{R_A} &= \frac{1}{R_2} + \frac{1}{R_3} \\ \frac{1}{R_A} &= \frac{1}{330} + \frac{1}{680} \\ R_A &= 222.22 \text{ ohms} \end{aligned}$$

Redraw the circuit, substituting resistor R_A for resistors R_2 and R_3 . See Figure 8-7.

Now determine series resistance R_{S_1} for resistors R_A and R_4 .

Given:	Solution:
$R_{S_1} = ?$	$R_{S_1} = R_A + R_4$
$R_A = 222.22$ ohms	$R_{S_1} = 222.22 + 470$
$R_4 = 470$ ohms	$R_{S_1} = 692.22$ ohms

Determine series resistance R_{S_2} for resistors R_5 and R_6 .

FIGURE 8-6

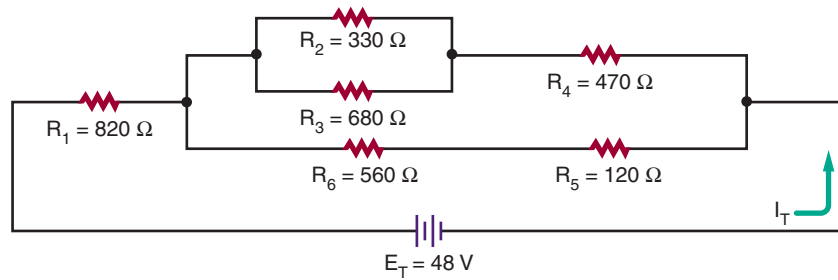


FIGURE 8-7

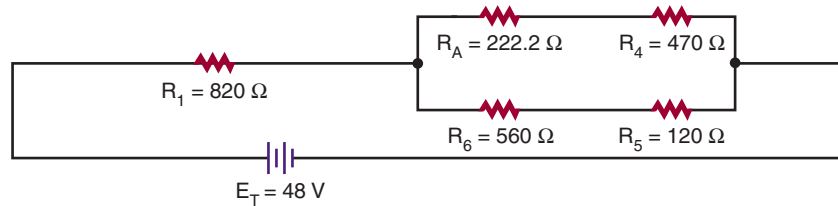
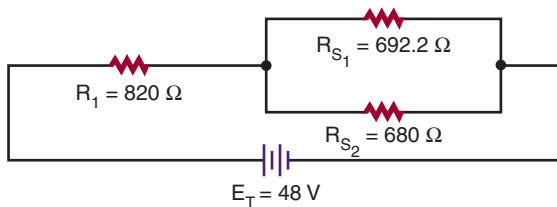


FIGURE 8-8



Given:

$$R_B = ?$$

$$R_{S_1} = 692.22 \text{ ohms}$$

$$R_{S_2} = 680 \text{ ohms}$$

Solution:

$$\frac{1}{R_B} = \frac{1}{R_{S_1}} + \frac{1}{R_{S_2}}$$

$$\frac{1}{R_B} = \frac{1}{692.22} + \frac{1}{680}$$

$$R_B = 343.64 \text{ ohms}$$

Given:

$$R_{S_2} = ?$$

$$R_5 = 120 \text{ ohms}$$

$$R_6 = 560 \text{ ohms}$$

Solution:

$$R_{S_2} = R_5 + R_6$$

$$R_{S_2} = 120 + 560$$

$$R_{S_2} = 680 \text{ ohms}$$

Redraw the circuit with resistors R_{S_1} and R_{S_2} . See Figure 8-8.

Now determine the parallel resistance (R_B) for resistors R_{S_1} and R_{S_2} .

Redraw the circuit using resistor R_B . See Figure 8-9.

Now determine the total resistance in the circuit.

Given:

$$R_T = ?$$

$$R_1 = 820 \text{ ohms}$$

$$R_B = 343.64 \text{ ohms}$$

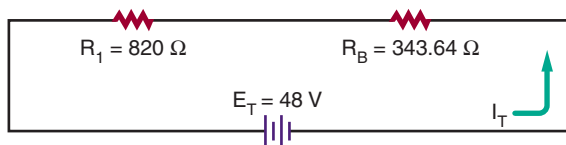
Solution:

$$R_T = R_1 + R_B$$

$$R_T = 820 + 343.64$$

$$R_T = 1163.64 \text{ ohms}$$

FIGURE 8-9



The total current in the circuit can now be determined using Ohm's law.

Given:

$$I_T = ?$$

$$E_T = 48 \text{ volts}$$

$$R_T = 1163.64 \text{ ohms} \quad I_T = 0.0412 \text{ amp or } 41.2 \text{ mA}$$

The voltage drop across resistor R_1 can now be determined.

Given:

$$I_{R_1} = 0.0412 \text{ amp}$$

$$E_{R_1} = ?$$

$$R_1 = 820 \text{ ohms}$$

Solution:

$$I_{R_1} = \frac{E_{R_1}}{R_1}$$

$$0.0412 = \frac{E_{R_1}}{820}$$

$$E_{R_1} = 33.78 \text{ volts}$$

The voltage drop across equivalent resistance R_B is:

Given:

$$I_{R_B} = 0.0412 \text{ amp}$$

$$E_{R_B} = ?$$

$$R_B = 343.64 \text{ ohms}$$

Solution:

$$I_{R_B} = \frac{E_{R_B}}{R_B}$$

$$0.0412 = \frac{E_{R_B}}{343.64}$$

$$E_{R_B} = 14.158 \text{ volts}$$

The current through each branch in a parallel circuit has to be calculated separately.

The current through branch resistance R_{S_1} is:

Given:

$$I_{R_{S_1}} = ?$$

$$E_{R_{S_1}} = 14.158 \text{ volts}$$

$$R_{S_1} = 692.22 \text{ ohms}$$

Solution:

$$I_{R_{S_1}} = \frac{E_{R_{S_1}}}{R_{S_1}}$$

$$I_{R_{S_1}} = \frac{14.158}{692.22}$$

$$I_{R_{S_1}} = 0.0205 \text{ amps}$$

The current through branch resistance R_{S_2} is:

Given:

$$I_{R_{S_2}} = ?$$

$$E_{R_{S_2}} = 14.158 \text{ volts}$$

$$R_{S_2} = 680 \text{ ohms}$$

Solution:

$$I_{R_{S_2}} = \frac{E_{R_{S_2}}}{R_{S_2}}$$

$$I_{R_{S_2}} = \frac{14.158}{680}$$

$$I_{R_{S_2}} = 0.0208 \text{ amp}$$

The voltage drop across resistors R_A and R_4 can now be determined.

Given:

$$I_{R_A} = 0.0205 \text{ amp}$$

$$E_{R_A} = ?$$

$$R_A = 222.22 \text{ ohms}$$

Solution:

$$I_{R_A} = \frac{E_{R_A}}{R_A}$$

$$0.0205 = \frac{E_{R_A}}{222.22}$$

$$E_{R_A} = 4.56 \text{ volts}$$

Given:

$$I_{R_4} = 0.0205 \text{ amp}$$

$$E_{R_4} = ?$$

$$R_4 = 470 \text{ ohms}$$

Solution:

$$I_{R_4} = \frac{E_{R_4}}{R_4}$$

$$0.0205 = \frac{E_{R_4}}{470}$$

$$E_{R_4} = 9.64 \text{ volts}$$

The voltage drop across resistors R_5 and R_6 is:

Given:

$$I_{R_5} = 0.0208 \text{ amp}$$

$$E_{R_5} = ?$$

$$R_5 = 120 \text{ ohms}$$

Given:

$$I_{R_6} = 0.0208 \text{ amp}$$

$$E_{R_6} = ?$$

$$R_6 = 560 \text{ ohms}$$

The current through equivalent resistance R_A splits through parallel branches with resistors R_2 and R_3 . Current through each resistor has to be calculated separately.

The current through resistor R_2 is:

Given:

$$I_{R_2} = ?$$

$$E_{R_2} = 4.56 \text{ volts}$$

$$R_2 = 330 \text{ ohms}$$

Given:

$$I_{R_3} = ?$$

$$E_{R_3} = 4.56 \text{ volts}$$

$$R_3 = 680 \text{ ohms}$$

Now the power dissipation through each resistor can be determined. The power consumed by resistor R_1 is:

Given:

$$P_{R_1} = ?$$

$$I_{R_1} = 0.0412 \text{ amp}$$

$$E_{R_1} = 33.78 \text{ volts}$$

Solution:

$$I_{R_5} = \frac{E_{R_5}}{R_5}$$

$$0.0208 = \frac{E_{R_5}}{120}$$

$$E_{R_5} = 2.50 \text{ volts}$$

Solution:

$$I_{R_6} = \frac{E_{R_6}}{R_6}$$

$$0.0208 = \frac{E_{R_6}}{560}$$

$$E_{R_6} = 11.65 \text{ volts}$$

Solution:

$$I_{R_2} = \frac{E_{R_2}}{R_2}$$

$$I_{R_2} = \frac{4.56}{330}$$

$$I_{R_2} = 0.0138 \text{ amp}$$

Solution:

$$I_{R_3} = \frac{E_{R_3}}{R_3}$$

$$I_{R_3} = \frac{4.56}{680}$$

$$I_{R_3} = 0.00671 \text{ amp}$$

Solution:

$$P_{R_1} = I_{R_1} E_{R_1}$$

$$P_{R_1} = (0.0412)(33.78)$$

$$P_{R_1} = 1.39 \text{ watts}$$

The power consumed by resistor R_2 is:

Given:

$$P_{R_2} = ?$$

$$I_{R_2} = 0.0138 \text{ amp}$$

$$E_{R_2} = 4.56 \text{ volts}$$

Solution:

$$P_{R_2} = I_{R_2} E_{R_2}$$

$$P_{R_2} = (0.0138)(4.56)$$

$$P_{R_2} = 0.063 \text{ watt or } 63 \text{ mW}$$

The power consumed by resistor R_3 is:

Given:

$$P_{R_3} = ?$$

$$E_{R_3} = 4.56 \text{ volts}$$

$$I_{R_3} = 0.00670 \text{ amp}$$

Solution:

$$P_{R_3} = I_{R_3} E_{R_3}$$

$$P_{R_3} = (0.00670)(4.56)$$

$$P_{R_3} = 0.031 \text{ watt or } 31 \text{ mW}$$

The power consumed by resistor R_4 is:

Given:

$$P_{R_4} = ?$$

$$E_{R_4} = 9.64 \text{ volts}$$

$$I_{R_4} = 0.0205 \text{ amp}$$

Solution:

$$P_{R_4} = I_{R_4} E_{R_4}$$

$$P_{R_4} = (0.0205)(9.64)$$

$$P_{R_4} = 0.20 \text{ watt or } 200 \text{ mW}$$

The power consumed by resistor R_5 is:

Given:

$$P_{R_5} = ?$$

$$E_{R_5} = 2.50 \text{ volts}$$

$$I_{R_5} = 0.0208 \text{ amp}$$

Solution:

$$P_{R_5} = I_{R_5} E_{R_5}$$

$$P_{R_5} = (0.0208)(2.50)$$

$$P_{R_5} = 0.052 \text{ watt or } 52 \text{ mW}$$

The power consumed by resistor R_6 is:

Given:

$$P_{R_6} = ?$$

$$E_{R_6} = 11.65 \text{ volts}$$

$$I_{R_6} = 0.0208 \text{ amp}$$

Solution:

$$P_{R_6} = I_{R_6} E_{R_6}$$

$$P_{R_6} = (0.0208)(11.65)$$

$$P_{R_6} = 0.24 \text{ watt or } 240 \text{ mW}$$

The total power consumption of the circuit is:

Given:

$$P_T = ?$$

$$P_{R_1} = 1.39 \text{ watts}$$

$$P_{R_2} = 0.063 \text{ watt}$$

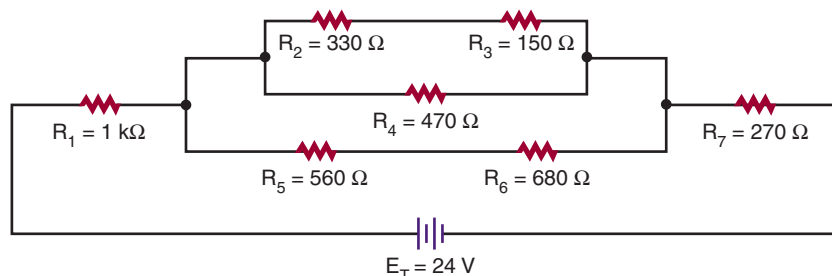
$$P_{R_3} = 0.031 \text{ watt}$$

$$P_{R_4} = 0.20 \text{ watt}$$

$$P_{R_5} = 0.052 \text{ watt}$$

$$P_{R_6} = 0.24 \text{ watt}$$

FIGURE 8-10



Solution:

$$P_T = P_{R_1} + P_{R_2} + P_{R_3} + P_{R_4} + P_{R_5} + P_{R_6}$$

$$P_T = 1.39 + 0.063 + 0.031 + 0.20 + 0.052 + 0.24$$

$$P_T = 1.98 \text{ watts}$$

The total power consumption could also be determined by the use of the power formula.

Given:

$$P_T = ?$$

$$E_T = 48 \text{ volts}$$

$$I_T = 0.0413 \text{ amp}$$

Solution:

$$P_T = E_T I_T$$

$$P_T = (48)(0.0413)$$

$$P_T = 1.98 \text{ watts}$$

8-3 QUESTION

1. Solve for all unknown values in Figure 8-10.

8-4 VOLTAGE DIVIDERS

One of the more common uses of resistors is voltage division, which is used extensively in electronics. Voltage dividers are often used to set a *bias* or operating point of various active electronic components such as transistors or integrated circuits. A voltage divider is also used to convert a higher voltage to a lower one so that an instrument can read or measure a voltage above its normal range. This is often referred to as *scaling*.

In Chapters 4–6, the concept of connecting resistors in series was presented. Ohm's law (presented in Chapter 5) is one of the most important concepts to understand because power formulas, voltage dividers, current dividers, and so on can all be traced back to and solved by it. Ohm's law states that the current through a circuit is directly proportional to the voltage across the circuit and inversely proportional to the resistance.

$$\text{current} = \frac{\text{voltage}}{\text{resistance}}$$

$$I = \frac{E}{R}$$

That the current is directly proportional to the voltage across the circuit is a very simple yet profound statement. The first part of the statement simply means that as the voltage changes, so does the current, and the change is in the same direction (i.e., if the voltage increases, then the current increases; similarly, if the voltage decreases, then the current decreases). The second part of Ohm's law states that current is inversely proportional to resistance. *Inversely proportional* simply means that when one thing occurs, the opposite happens to the other quantity. In this case, if resistance increases, then current decreases.

Figure 8-11 depicts the simplest of circuits. It has a single voltage source of 10 volts, which is connected to a single 10-kΩ resistor. By Ohm's law, 1 milliamperes of current is flowing in this circuit.

FIGURE 8–11

Simple circuit.

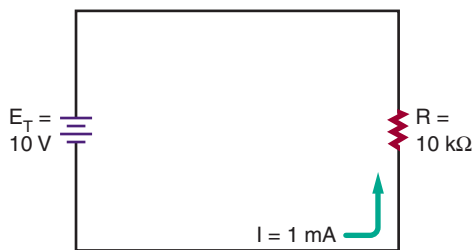
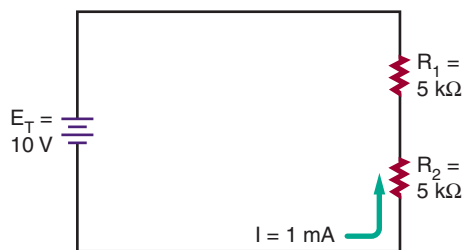


FIGURE 8–12

Simple voltage divider.



$$I = \frac{E}{R}$$

$$I = 10/10000$$

$$I = 0.001 \text{ A or } 1 \text{ mA}$$

In Figure 8–12, the original 10-k Ω resistor in Figure 8–11 is shown divided into two equal resistors, R_1 and R_2 . This circuit still has the same total resistance as Figure 8–11 and therefore has the same amount of current flowing through it (i.e., 1 mA). Ohm's law can be used to determine the voltage across each of the resistors.

$$I_1 = \frac{E_1}{R_1}$$

$$0.001 = E_1/5000$$

$$5 \text{ V} = E_1$$

Therefore

$$I_2 = \frac{E_2}{R_2}$$

$$0.001 = E_2/5000$$

$$5 \text{ V} = E_2$$

The voltage drop across R_1 and R_2 has effectively divided the source voltage of 10 volts in half.

Now, let us take Figure 8–12 another step and divide resistor R_2 into two resistors, R_2 and R_3 , which are 4 k Ω and 1 k Ω , as shown in Figure 8–13. As far as the voltage source is concerned, nothing has really changed in the circuit because the total resistance is still 10 k Ω . There is still 1 mA of current flowing in the circuit. The important difference is that now there are multiple voltage drops. The voltage drop at the junction of R_1 and R_2 is still 5 volts. However, at the junction of R_2 and R_3 to the ground reference point, the voltage drop is 1 volt.

The product of this discussion is depicted in Figure 8–14. It represents a 10-volt voltage source connected to a 10-k Ω potentiometer, or *pot*. As the wiper moves up and down, the overall value of the pot does not change as in the earlier examples. However, the value of the resistance between the wiper and the top of the pot does, thus effectively creating a two-resistor divider of any value where the resistors can be between zero and the value of the pot. This is a common control used to set voltages, audio levels (volume control), and so on. A word of warning: This voltage divider action is predictable only when these simple circuits are connected to resistances greater than they are. For example, if the 1-volt drop in Figure 8–13 were supplying a load less than approximately 10-k Ω , then, because it is in parallel with R_3 , the load would reduce its value, thus changing the voltage divider action (Figure 8–15).

What may not be obvious is that voltage dividers work on a ratio principle. Look at Figure 8–12. Resistor R_2 is 5 k Ω , which just happens to be half (or 50%) of the total network. It also happens to have half (or 50%) of the total supplied voltage dropped across it. Inspection of Figure 8–13 depicts a similar event occurring. Resistor R_3 is 1 k Ω , which just happens to be one-tenth (or 10%) of the total network resistance. In this case, the voltage dropped across it is 10% of the supplied voltage, or 1 volt. The voltage R_2 remains

FIGURE 8-13

Voltage divider.

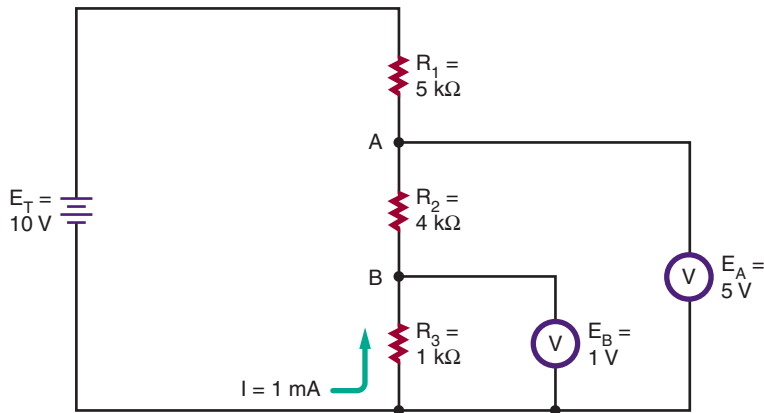
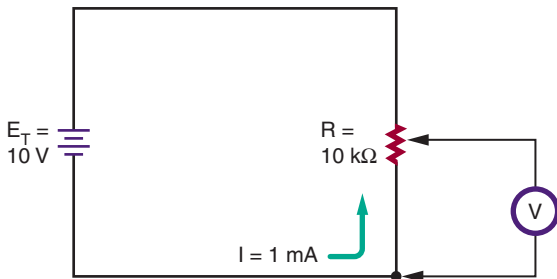


FIGURE 8-14

Voltage divider application.



unchanged because the sum of the resistances R_2 and R_3 make up R_2 voltage, and their combined value is still $5\text{ k}\Omega$.

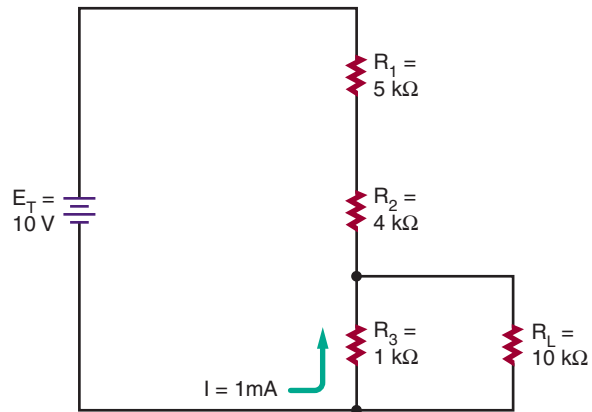
A generalization can be stated for voltage dividers of this nature. The voltage drop is equal to the percentage of the dropping resistor to the sum of the dropping network.

$$E_{\text{Drop}} = \frac{E_{\text{source}} \times R_{\text{Drop}}}{R_{\text{Total}}}$$

The next example (Figure 8-16) is a more practical example of a real-world voltage divider. The voltage source is the standard automotive accessory power source of 14.8 volts. What is de-

FIGURE 8-15

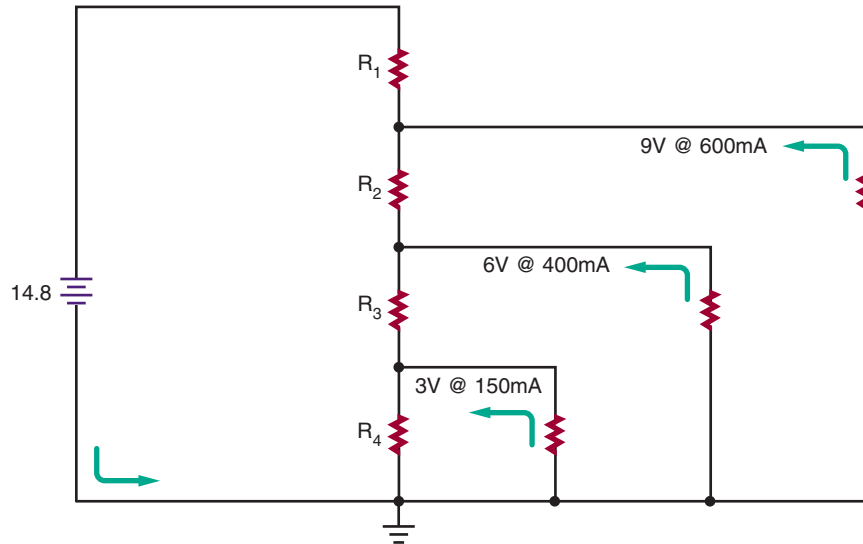
Voltage divider with load.



sired is a voltage-divider network that will divide this 14.8-volt source into a lower-voltage source specified by the manufacturer of a tape or CD player. The first voltage desired is 3 volts, and the load for this voltage will draw 150 mA. The second voltage required is 6 volts, and this voltage's load will draw 400 mA. The final voltage required is 9 volts, and its load draws 600 mA. Reviewing Figure 8-16 indicates that both series and parallel networks are involved. It is necessary to know the load currents for each voltage in advance.

FIGURE 8–16

Real-world voltage divider.



At first glance, the design of this circuit may seem very complex. In reality it is a simple process. Refer to Figure 8–17. Selecting the amount of current that is desired to flow through resistor R_4 starts the process. In this example, an arbitrary value of 10 mA was chosen.

Next, inspect junction A between resistors R_3 and R_4 . At this point, there is current summing or addition. There is 10 mA of current flowing through R_4 , and it is joined or summed with 150 mA of current through the 3-volt load, R_{L3} . This means that a total of 160 mA of current is flowing through resistor R_3 .

At junction B between resistors R_2 and R_3 , there is another summation process. The 400 mA of current flowing through the 6-volt load now joins the 160 mA of current through R_3 . The total amount of current flowing through resistor R_2 is this summation, or 560 mA.

Junction C has 560 mA of current entering it through the divider chain, and it is summed with the current from the 9-volt load, which is 600 mA. This summation becomes the total current flow-

ing through the final resistor R_1 to be a value of 1160 mA, or 1.16 A.

The final step in the process is calculating the values of R_1 , R_2 , R_3 , and R_4 . These calculations involve nothing more than applying Ohm's law. Again, start at the bottom of the network with resistor R_4 . At this point in the circuit, it is determined that there is only the previously selected 10 mA of current flowing. The desired voltage at junction A is 3 volts. Therefore, the following relationships exist:

$$I_4 = \frac{E_4}{R_4}$$

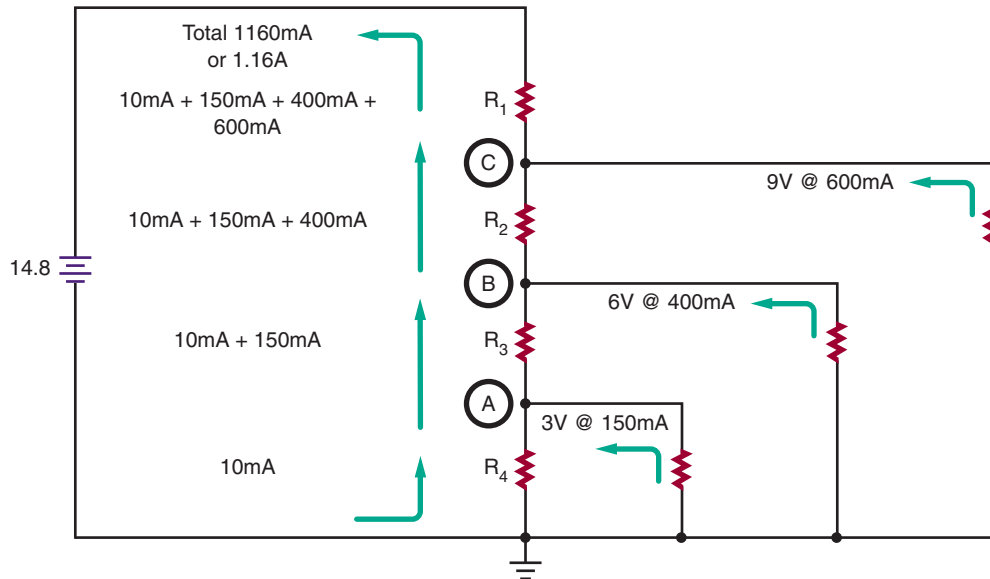
$$0.01 = \frac{3}{R_4}$$

$$300 \Omega = R_4$$

The calculation of R_3 is only slightly more difficult. From the previous calculations, the total current flowing through the resistor was determined to be 160 mA. Remember that voltage dividers are ratios, or the relation of one potential point to another. The desired voltage junction B is

FIGURE 8-17

Analyzing the circuit.



6 volts. However, this voltage is not used in the calculation. Junction B is above junction A, which has been established at 3 volts. Therefore, junction B is $6\text{ V} - 3\text{ V}$, or 3 V greater than junction A. This value is used in the calculation of resistor R_3 .

$$I_3 = \frac{E_3}{R_3}$$

$$0.160 = \frac{3}{R_3}$$

$$18.75\ \Omega = R_3$$

The process is repeated in the calculation of R_2 . The current flowing through R_2 is 560 mA. The desired voltage at junction A is 9 volts. Junction A is $9\text{ V} - 6\text{ V}$, or 3 volts more than at junction B.

$$I_2 = \frac{E_2}{R_2}$$

$$0.560 = \frac{3}{R_2}$$

$$5.36\ \Omega = R_2$$

The final calculation to determine the value of resistor R_1 is somewhat different. In this case, the

total current flowing through the circuits is 1.16 A. In this example, the junction A desired voltage is 9 volts. The source voltage is 14.8 volts; therefore, resistor R_1 must drop $14.8\text{ V} - 9\text{ V}$, or 5.8 volts.

$$I_1 = \frac{E_1}{R_1}$$

$$1.16 = \frac{5.8}{R_1}$$

$$5\ \Omega = R_1$$

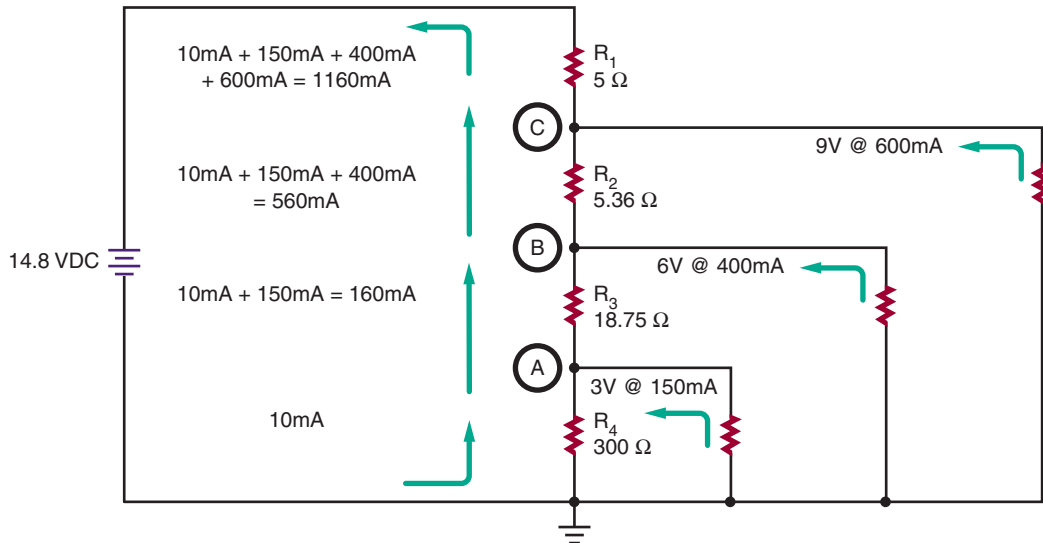
As in the real world, the resistor values required in this circuit are not exact values but are rounded (Figure 8-18).

NOTE: THE VALUES OF RESISTORS INDICATED BY THE COMPUTER SIMULATIONS WILL NOT PRECISELY MATCH THE CALCULATED VALUES. AGAIN, THIS IS A REAL-WORLD SIMULATION, AND THE RESISTORS' VALUES ARE NOT CARRIED PAST 1 OHM.

A REAL-WORLD AMMETER HAS SOME INTERNAL RESISTANCE ASSOCIATED WITH IT, AND A REAL-WORLD VOLTMETER HAS SOME CURRENT FLOWING THROUGH IT.

FIGURE 8-18

Determining the resistor values.



BOTH OF THESE DEVICES WILL CAUSE THE DISPLAYED VALUES TO BE SLIGHTLY DIFFERENT FROM THOSE CALCULATED.

COMPUTER SIMULATIONS USE CALCULATED VALUES, AND THIS PRESENTS A COMMON PROBLEM IN ELECTRONICS. COMPONENTS ARE MANUFACTURED IN STANDARD VALUES, AND USUALLY ONLY THESE VALUES ARE AVAILABLE WHEN A CIRCUIT NEEDS TO BE CONSTRUCTED.

THE ONLY WAY TO OBTAIN A RESISTOR SUCH AS RESISTOR R_2 ($5.36\ \Omega$) OR R_3 ($18.75\ \Omega$) IS TO SPEND A LARGE AMOUNT OF MONEY FOR A CUSTOM-MADE RESISTOR. THE STUDENT SHOULD REALIZE THE GOAL IS ALMOST ALWAYS TO DESIGN AND BUILD PRACTICAL AND ECONOMICAL EQUIPMENT. THE USE OF PRECISION COMPONENTS OFTEN INCREASES COSTS WITH LITTLE OR NO BENEFIT.

8-4 QUESTIONS

1. What function does a voltage divider perform?
2. What is a common function for voltage dividers?

3. What principle do voltage dividers work on?
4. What generalization can be stated for voltage dividers?
5. Design a voltage divider to use a 14.8-V voltage source to control a 3 V load at 300 mA.

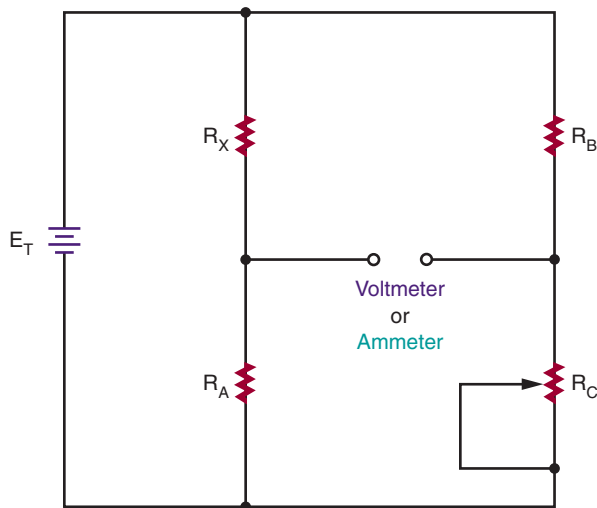
8-5 WHEATSTONE BRIDGE

A Wheatstone bridge is a measuring instrument that was invented by Samuel Hunter Christie in 1833. In 1843, a talented and versatile scientist named Sir Charles Wheatstone improved on the original design of the Wheatstone bridge. He did not claim to have invented the circuit named after him, but he was the first to use the circuit effectively for making resistance measurements.

The Wheatstone bridge consists essentially of two voltage dividers (Figure 8-19). It is used to measure an unknown electrical resistance by balancing one leg of which includes the unknown

FIGURE 8-19

A Wheatstone bridge consists of two voltage dividers.



component against another leg of known components with one being variable.

In the circuit, R_X is the unknown resistor value. R_C is a potentiometer and is adjusted until the voltage from the second voltage divider is equal to voltage from the voltage divider containing R_X . When the voltage values are equal, the bridge is said to be balanced. The balance point can be detected by connecting either a voltmeter or an ammeter across the output terminals. Both meters will give a zero reading when a balance is achieved.

NOTE: A DIGITAL METER WORKS WELL FOR THIS APPLICATION.

In a balanced circuit, the ratio R_X / R_A is equal to the ratio R_B / R_C .

$$\frac{R_X}{R_A} = \frac{R_B}{R_C}$$

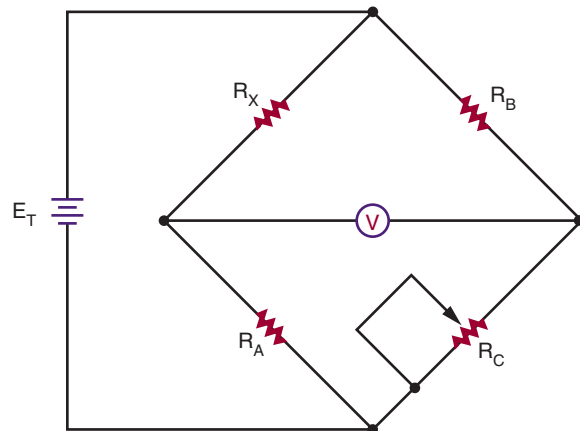
Therefore:

$$R_X = \frac{R_A \times R_B}{R_C}$$

In other words, if the values of R_A , R_B and R_C are known, it is easy to calculate R_X . R_C would

FIGURE 8-20

Wheatstone bridge schematic.



have to be measured with a meter to determine its value after adjusting for a zero reading. In an actual Wheatstone bridge test instruments, R_A and R_B are fixed and R_C is adjusted and R_X can be easily read off a sliding scale connected to R_C .

The circuit for a Wheatstone bridge as designed by Wheatstone is shown in Figure 8-20. This is how the circuit is drawn for applications using it.

Variations on the Wheatstone bridge can be used to measure capacitance, inductance, and impedance. Wheatstone bridge circuits are rarely used today to measure resistance values. They are now used for designing sensing circuits such as: strain gauges for transforming a strain applied, to a proportional change of resistance and are widely used in industry; variometers to detect changes in air pressure to alerting glider pilots to updrafts or thermals so height can be gained allowing for longer flights; and explosimeters for sampling the amount of combustible gases in a space.

8-5 QUESTIONS

1. Who invented the Wheatstone bridge?
2. What is the Wheatstone bridge circuit constructed of?

3. When the meter reads zero, what does this mean?
4. What is the value of R_X when R_A and R_B are 10 k Ω each and R_C is 96,432 Ω ?
5. What are other quantities that can be measured using the Wheatstone bridge concept?
6. What applications are used today for the Wheatstone bridge?

SUMMARY

- A series circuit provides only one path for current flow.
- Formulas governing the operation of a series circuit include:

$$I_T = I_{R_1} = I_{R_2} = I_{R_3} \dots = I_{R_n}$$

$$R_T = R_1 + R_2 + R_3 \dots + R_n$$

$$E_T = E_{R_1} + E_{R_2} + E_{R_3} \dots + E_{R_n}$$

$$I = E/R$$

$$P_T = P_{R_1} + P_{R_2} + P_{R_3} \dots + P_{R_n}$$

- A parallel circuit provides more than one path for current flow.
- Formulas governing the operation of a parallel circuit include:

$$I_T = I_{R_1} + I_{R_2} + I_{R_3} \dots + I_{R_n}$$

$$\frac{1}{R_T} = \frac{1}{R_1} + \frac{1}{R_2} + \frac{1}{R_3} \dots + \frac{1}{R_n}$$

$$E_T = E_{R_1} = E_{R_2} = E_{R_3} \dots = E_{R_n}$$

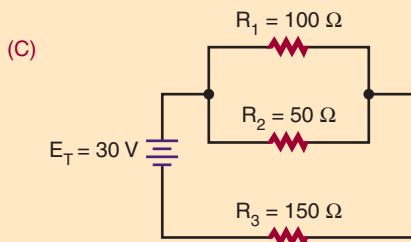
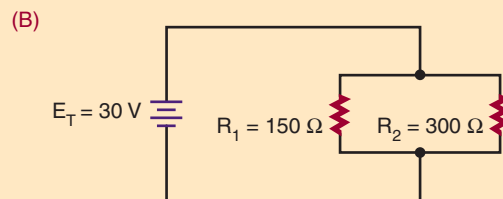
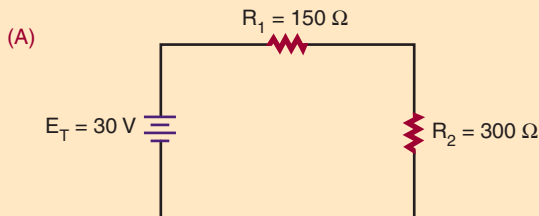
$$I = E / R$$

$$P_T = P_{R_1} + P_{R_2} + P_{R_3} \dots + P_{R_n}$$

- Series-parallel circuits are solved by using series formulas for the series parts of the circuit and parallel formulas for the parallel parts of the circuit.
- Voltage dividers are used to set the bias or operating point of active electronic components.
- A Wheatstone bridge is used to measure an unknown electrical resistance.

CHAPTER 8 SELF-TEST

1. Solve for all unknown quantities in the circuits shown.



Magnetism

OBJECTIVES

After completing this chapter, the student will be able to:

- Identify three types of magnets.
- Describe the basic shapes of magnets.
- Describe the differences between permanent magnets and temporary magnets.
- Describe how the earth functions as a magnet.
- State the laws of magnetism.
- Explain magnetism based on the theory of atoms and electron spin.
- Explain magnetism based on the domain theory.
- Identify flux lines and their significance.
- Define *permeability*.
- Describe the magnetic effects of current flowing through a conductor.
- Describe the principle of an electromagnet.
- Describe how to determine the polarity of an electromagnet using the left-hand rule.
- Define *magnetic induction*.
- Define *retentivity* and *residual magnetism*.
- Define a *magnetic shield*.
- Describe how magnetism is used to generate electricity.
- State the basic law of electromagnetism.
- Describe how the left-hand rule for generators can be used to determine the polarity of induced voltage.
- Describe how AC and DC generators convert mechanical energy into electrical energy.
- Describe how a relay operates as an electromechanical switch.

- Discuss the similarities between a doorbell and a relay.
- Discuss the similarities between a solenoid and a relay.
- Describe how a magnetic phonograph cartridge works.
- Describe how a loudspeaker operates.
- Describe how information can be stored and retrieved using magnetic recording.
- Describe how a DC motor operates.



See accompanying CD for interactive presentations and tutorials relating to Chapter 9.

Electricity and magnetism are inseparable. To understand electricity means to understand the relationship that exists between magnetism and electricity.

Electric current always produces some form of magnetism, and magnetism is the most common method for generating electricity. In addition, electricity behaves in specific ways under the influence of magnetism.

This chapter looks at magnetism, electromagnetism, and the relationship between magnetism and electricity.

9-1 MAGNETIC FIELDS

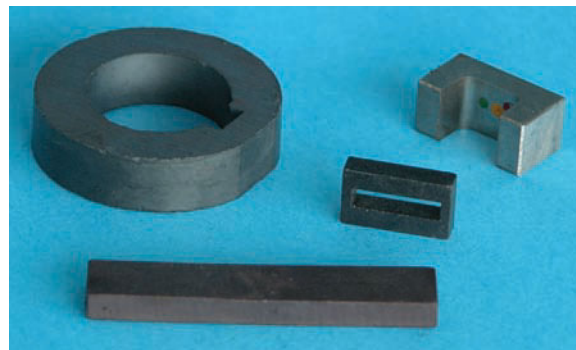
The word **magnet** is derived from *magnetite*, the name of a mineral found in Magnesia, a part of Asia Minor. This mineral is a natural magnet. Another type of magnet is the **artificial magnet**. This magnet is created by rubbing a piece of soft iron with a piece of magnetite. A third type of magnet is the **electromagnet**. It is created by current flowing through a coil of wire.

Magnets come in various shapes (Figure 9-1). Among the more common shapes are the horseshoe, the bar or rectangle, and the ring.

Magnets that retain their magnetic properties are called **permanent magnets**. Magnets that retain only a small portion of their magnetic properties are called **temporary magnets**.

FIGURE 9-1

Magnets come in various sizes and shapes.



Magnets are made of metallic or ceramic materials. Alnico (*aluminum, nickel, and cobalt*) and Cunife (*copper [Cu], nickel, and Iron [Fe]*) are two metallic alloys used for magnets.

The earth itself is a huge magnet (Figure 9-2). The earth's magnetic North and South Poles are situated close to the geographic north and south poles. If a bar magnet is suspended, the magnet aligns in a north-south direction, with one end pointing toward the North Pole of the earth and the other toward the South Pole. This is the principle behind the compass. It is also the reason the two ends of the magnet are called the north pole and the south pole.

Magnets align in a north-south direction because of laws similar to those of positive and negative charges: Unlike magnetic poles attract each

FIGURE 9-2

The earth's magnetic north and south poles are situated close to the geographic North and South Poles.

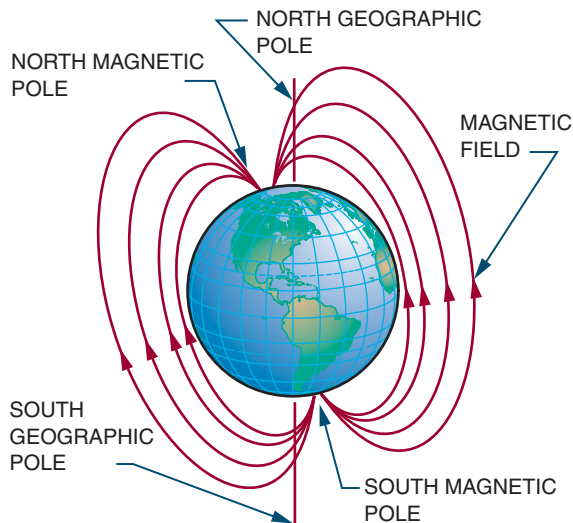
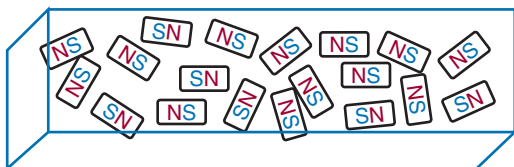


FIGURE 9-3

The domains in unmagnetized material are randomly arranged with no overall magnetic effect.

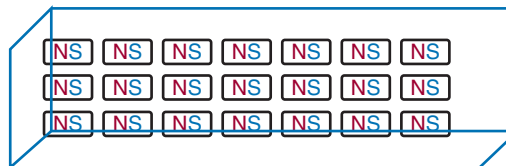


other and like magnetic poles repel each other. The color code for a magnet is red for the north pole and blue for the south pole.

Magnetism, the property of the magnet, can be traced to the atom. As electrons orbit around the nucleus of the atom, they spin on their axis, like the earth as it orbits the sun. This moving electrostatic charge produces a magnetic field. The direction of the magnetic field depends on the electron's direction of spin. Iron, nickel, and cobalt are the only naturally magnetic elements. Each of these materials has two valence electrons that spin in the same direction. Electrons in other

FIGURE 9-4

When material becomes magnetized, all the domains align in a common direction.



materials tend to spin in opposite directions and this cancels their magnetic characteristics.

Ferromagnetic materials are materials that respond to magnetic fields. In ferromagnetic materials, the atoms combine into *domains*, or groups of atoms arranged in the form of magnets. In an unmagnetized material, the magnetic domains are randomly arranged, and the net magnetic effect is zero (Figure 9-3). When the material becomes magnetized, the domains align in a common direction and the material becomes a magnet (Figure 9-4). If the magnetized material is divided into smaller pieces, each piece becomes a magnet with its own poles.

Evidence of this "domain theory" is that if a magnet is heated, or hit repeatedly with a hammer, it loses its magnetism (the domains are jarred back into a random arrangement). Also, if an artificial magnet is left by itself, it slowly loses its magnetism. To prevent this loss, bar magnets should be stacked on top of each other with opposite poles together; keeper bars should be placed across horseshoe magnets (Figure 9-5). Both methods maintain the magnetic field.

A *magnetic field* consists of invisible lines of force that surround a magnet. These lines of force are called *flux lines*. They can be "seen" by placing a sheet of paper over a magnet and sprinkling iron filings on the paper. When the paper is lightly tapped, the iron filings arrange themselves into a definite pattern that reflects the forces attracting them (Figure 9-6).

FIGURE 9-5

To prevent loss of magnetism, (A) bar magnets are stacked on top of each other, and (B) keeper bars are placed across horseshoe magnets.

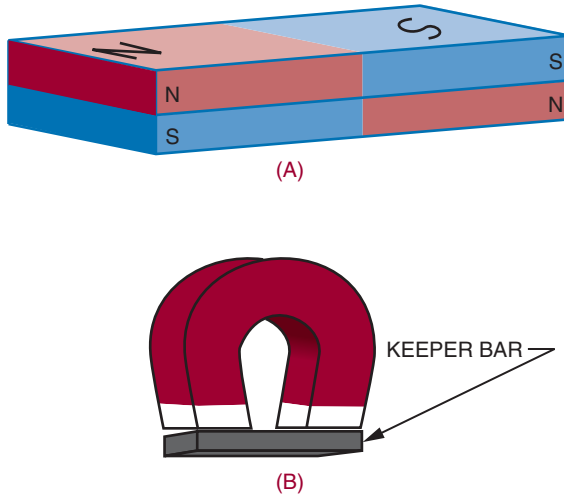
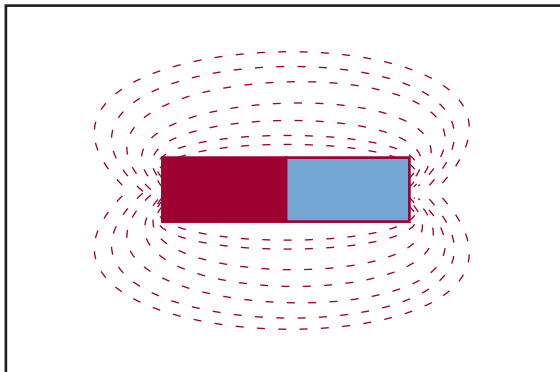


FIGURE 9-6

Magnetic lines of flux can be seen in patterns of iron filings.



Flux lines have several important characteristics: They have polarity from north to south. They always form a complete loop. They do not cross each other because like polarities repel. They tend to form the smallest loop possible, because unlike poles attract and tend to pull together.

The characteristic that determines whether a substance is ferromagnetic or not is called *permeability*. Permeability is the ability of a material to accept magnetic lines of force. A material with great permeability offers less resistance to flux lines than air.

9-1 QUESTIONS

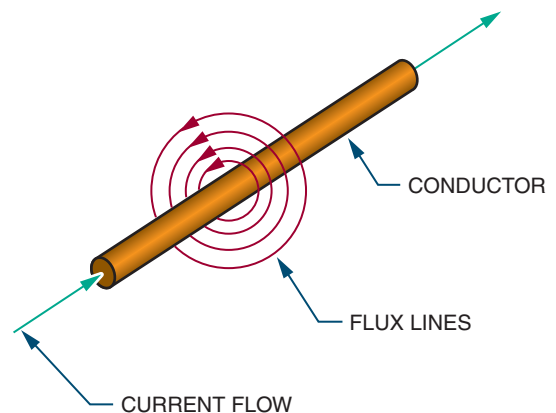
1. What are the three types of magnets?
2. What are the basic shapes of magnets?
3. How are the ends of a magnet identified?
4. What are the two laws of magnetism?
5. What are flux lines?

9-2 ELECTRICITY AND MAGNETISM

When current flows through a wire, it generates a **magnetic field** around the wire (Figure 9-7). This can be shown by placing a compass next to a wire that has no current flowing through it. The compass aligns itself with the earth's magnetic field.

FIGURE 9-7

A current flowing through a conductor creates a magnetic field around the conductor.



When current passes through the wire, however, the compass needle is deflected and aligns itself with the magnetic field generated by the current. The direction of the flux lines is indicated by the North Pole of the compass. The direction of the flux lines can also be determined if the direction of the current flow is known. If the wire is grasped with the left hand, with the thumb pointing in the direction of current flow, the fingers point in the direction of the flux lines (Figure 9–8). When the polarity of the voltage source is reversed, the flux lines are also reversed.

If two wires are placed next to each other with current flowing in opposite directions, they create opposing magnetic fields that repel each other (Figure 9–9). If the two wires carry current

FIGURE 9–9

When current flows in opposite directions through two conductors placed next to each other, the resulting magnetic fields repel each other.

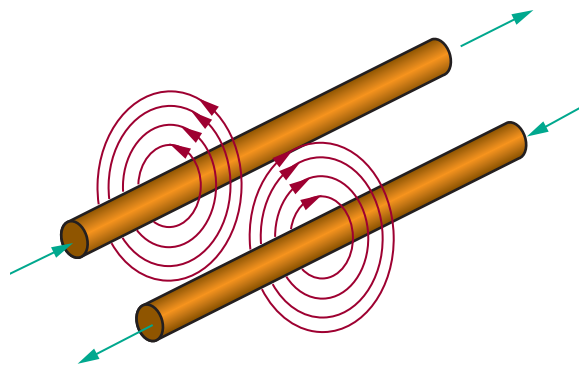


FIGURE 9–8

Determining the direction of the flux lines around a conductor when the direction of the current flow is known (left hand rule for conductors).

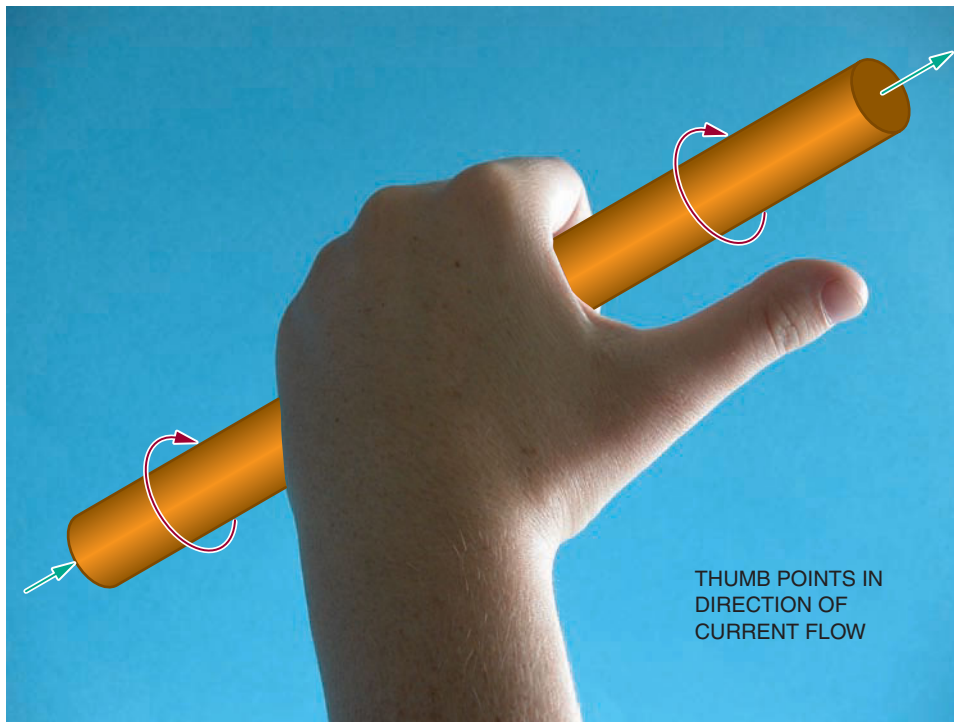
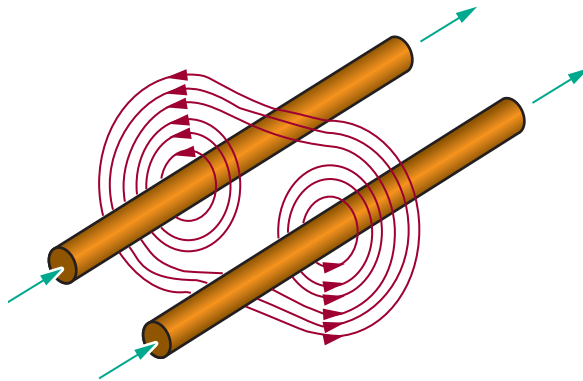


FIGURE 9-10

When current flows in the same direction through two conductors placed next to each other, the magnetic fields combine.



flowing in the same direction, the fields combine (Figure 9-10).

A single piece of wire produces a magnetic field with no north or south pole and little strength or practical value. If the wire is twisted into a loop, three things occur. One, the flux lines are brought together. Two, the flux lines are concentrated at the center of the loop. Three, a north and south pole are established. This is the principle of the electromagnet.

An electromagnet is composed of many turns of wire close together. This allows the flux lines to add together when a current flows through the wire. The more turns of wire, the more flux lines are added together. Also, the greater the current, the greater the number of flux lines generated. The strength of the magnetic field, then, is directly proportional to the number of turns in the coil and the amount of current flowing through it.

A third method of increasing the strength of the magnetic field is to insert a ferromagnetic core into the center of the coil. An iron core is typically used because it has a higher permeability (can support more flux lines) than air.

To determine the polarity of the electromagnet, grasp the coil with the left hand, with the fingers pointing in the direction of the current flow. The thumb then points in the direction of the north pole (Figure 9-11).

9-2 QUESTIONS

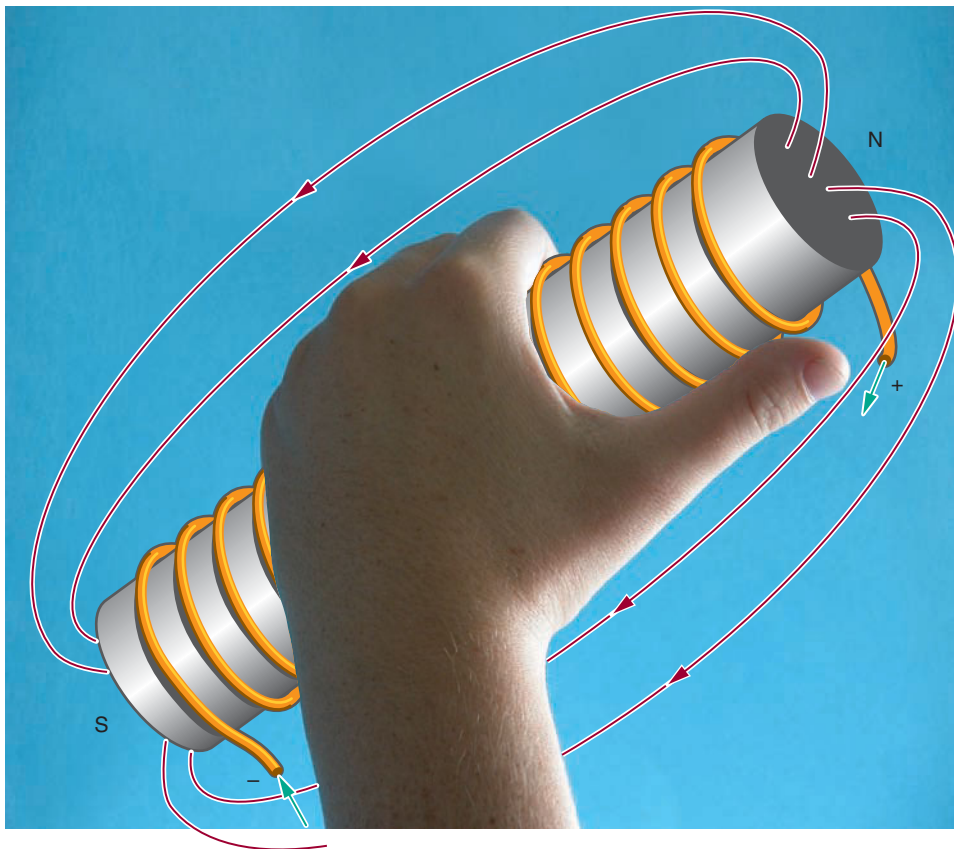
1. How can a magnetic field be shown to exist when a current flows through a wire?
2. How can the direction of flux lines around a wire be determined?
3. What happens when two current-carrying wires are placed next to each other with the current flowing in:
 - a. The same direction?
 - b. Opposite directions?
4. What are three ways to increase the strength of an electromagnetic field?
5. How can the polarity of an electromagnet be determined?

9-3 MAGNETIC INDUCTION

Magnetic induction is the effect a magnet has on an object without physical contact. For example, a magnet may induce a magnetic field in an iron bar (Figure 9-12). In passing through the iron bar, the magnetic lines of force cause the domains in the iron bar to align in one direction. The iron bar is now a magnet. The domains in the iron bar align themselves with their south pole toward the north pole of the magnet, because opposite poles attract. For the same reason, the iron bar is drawn toward the magnet. The flux lines now leave from the end of the iron bar; the iron bar is an extension of the magnet. This is an effective way to increase the length or change the shape of a magnet without physically altering it.

FIGURE 9–11

Determining the polarity of an electromagnet.



When the magnet and iron bar are separated, the domains in the iron bar return to their random pattern, although a few domains remain in north–south alignment, giving the iron bar a weak magnetic field. This remaining magnetic field is called *residual magnetism*. The ability of a material to retain its magnetic field after the magnetizing force is removed is called *retentivity*. Soft iron has low retentivity. Alnico, an alloy made of aluminum, nickel, and cobalt, has high retentivity.

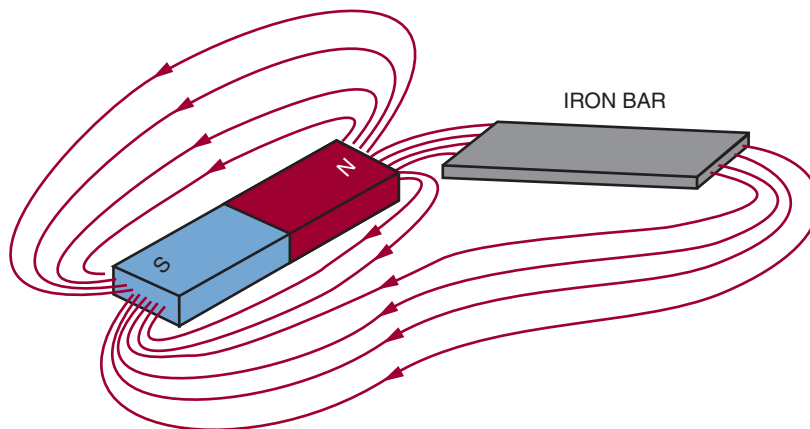
Flux lines can be bent by inserting a low-reluctance material in front of the magnetic field. Low-reluctance materials are called *magnetic shields*.

An example is the material called Mu-metal. The magnetic shield is placed around the item to be protected. Electronic equipment, especially oscilloscopes, require shielding from magnetic flux lines.

Electromagnetic induction is the principle behind the generation of electricity: When a conductor passes or is passed by a magnetic field, a current is produced (induced) in the conductor. As the conductor passes through the magnetic field, free electrons are forced to one end of the conductor, leaving a deficiency of electrons at the other end. This results in a difference of potential between the ends of the conductor. This

FIGURE 9–12

Placing an iron bar in a magnetic field extends the magnetic field and magnetizes the iron bar.



difference of potential exists only when the conductor is passing through a magnetic field. When the conductor is removed from the magnetic field, the free electrons return to their parent atoms.

For electromagnetic induction to occur, either the conductor must move or the magnetic field must move. The voltage produced in the conductor is called *induced voltage*. The amount of induced voltage is determined by the strength of the magnetic field, the speed with which the conductor moves through the magnetic field, the angle at which the conductor cuts the magnetic field, and the length of the conductor.

The stronger the magnetic field, the greater the induced voltage. The faster the conductor moves through the field, the greater the induced voltage. Motion between the conductor and the magnetic field can be produced by moving the conductor, the magnetic field, or both. The maximum voltage is induced when the conductor moves at right angles to the field. Angles less than 90 degrees induce less voltage. If a conductor is moved parallel to the flux lines, no voltage is induced. The longer the conductor, the greater the induced voltage.

Faraday's law, the basic law of electromagnetism, states: The induced voltage in a conductor is directly proportional to the rate at which the conductor cuts the magnetic lines of force.

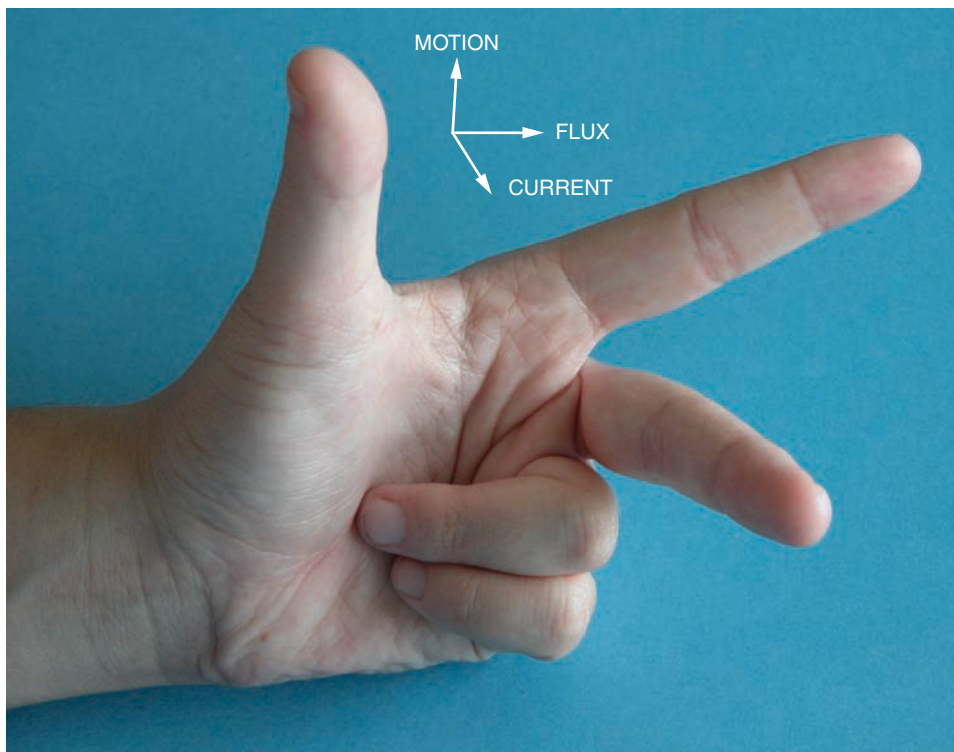
The polarity of an induced voltage can be determined by the following left-hand rule for generators: The thumb, index finger, and middle finger are held at right angles to each other (Figure 9–13). The thumb points in the same direction as the motion of the conductor, the index finger points in the direction of the flux lines (north to south), and the middle finger points toward the negative end of the conductor, the direction of the current flow.

9–3 QUESTIONS

1. How can the length of a magnet be increased without physically altering the magnet?
2. What is residual magnetism?
3. How does a magnetic shield work?
4. How is electromagnetic induction used to generate electricity?

FIGURE 9-13

The left-hand rule for generators can be used to determine the direction of the induced current flow in a generator.



9-4 MAGNETIC AND ELECTROMAGNETIC APPLICATIONS

An alternating current (AC) generator converts mechanical energy to electrical energy by utilizing the principle of electromagnetic induction. The mechanical energy is needed to produce motion between the magnetic field and the conductor.

Figure 9-14 shows a loop of wire (conductor) being rotated (moved) in a magnetic field. The loop has a light and dark side for ease of explanation. At the point shown in part A, the dark half is parallel to the lines of force, as is the light half. No voltage is induced. As the loop is rotated toward the position shown in part B, the lines of force are

cut and a voltage is induced. The induced voltage is greatest at this position, when the motion is at right angles to the magnetic field. As the loop is rotated to position C, fewer lines of force are cut and the induced voltage decreases from the maximum value to zero volts. At this point the loop has rotated 180 degrees, or half a circle.

The direction of current flow can be determined by applying the left-hand rule for generators. The direction of current flow at position B is shown by the arrow. When the loop is rotated to position D, the action reverses. As the dark half moves up through the magnetic lines of force and the light half moves down, applying the left-hand rule for generators shows that the induced voltage changes polarities. The voltage reaches a peak at

FIGURE 9-14

Induced voltage in an AC generator.

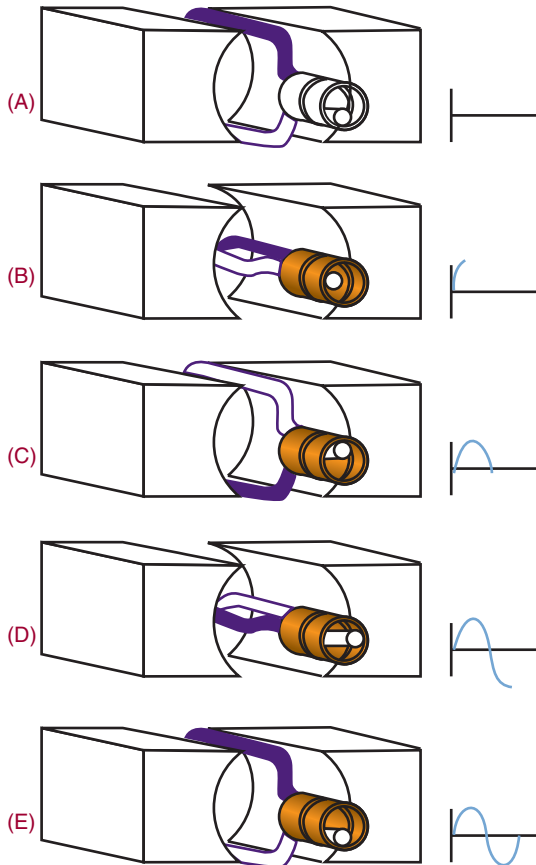
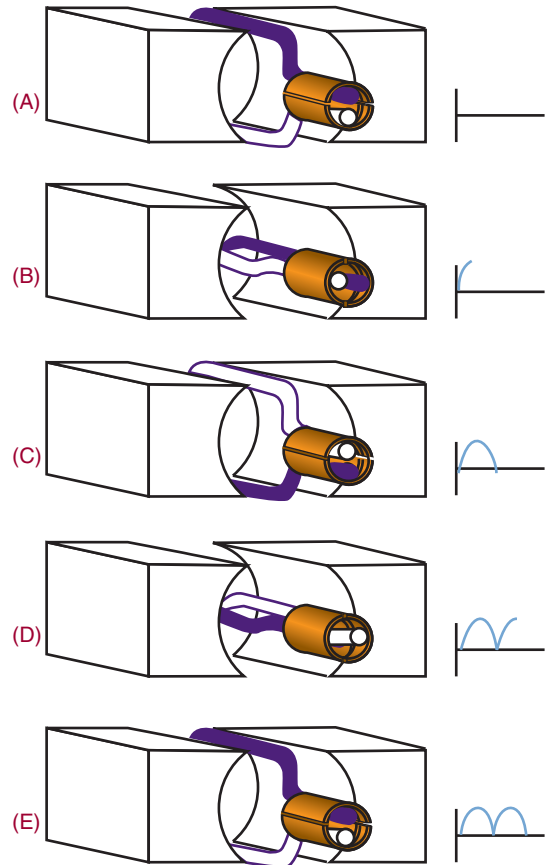


FIGURE 9-15

Induced voltage in a DC generator.



position D and decreases until the loop reaches the original position. The induced voltage has completed one cycle of two alternations.

The rotating loop is called an **armature** and the source of the electromagnetic field is called the *field*. The armature can have any number of loops. The term “armature” refers to the part that rotates in the magnetic field, regardless of whether it consists of one loop or multiple loops. The *frequency* of the alternating current or voltage is the number of complete cycles completed per second. The speed of rotation determines the frequency. An AC generator is often called an *alternator* because it produces alternating current.

A direct current (DC) generator also converts mechanical energy into electrical energy. It functions like an AC generator with the exception that it converts the AC voltage to DC voltage. It does this with a device called a *commutator*, as shown in Figure 9-15. The output is taken from the commutator, a split ring. When the loop is rotated from position A to position B, a voltage is induced. The induced voltage is greatest as the motion is at right angles to the magnetic field. As the loop is rotated to position C, the induced voltage decreases from the maximum value to zero. As the loop continues to rotate to position D, a voltage is induced, but the commutator reverses the output

FIGURE 9–16

Examples of various types of relays.



polarity so that it remains the same as before. The loop then returns to the original position, E. The voltage generated from the commutator pulsates, but in one direction only, varying twice during each revolution between zero and maximum.

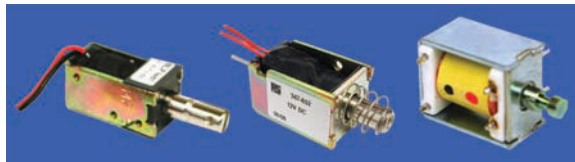
A **relay** is an electromechanical switch that opens and closes with an electromagnetic coil (Figure 9–16). As a current flows through the coil, it generates a magnetic field that attracts the plunger, pulling it down. As the plunger is pulled down, it closes the switch contacts. When the current through the coil stops, a spring pulls the armature back to its original position and opens the switch.

A relay is used where it is desirable to have one circuit control another circuit. It electrically isolates the two circuits. A small voltage or current can control a large voltage or current. A relay can also be used to control several circuits some distance away.

A doorbell is an application of the relay. The striker to ring the bell is attached to the plunger. As the doorbell is pressed, the relay coil is energized, pulling down the plunger and striking the bell. As the plunger moves down, it opens the circuit, de-energizing the relay. The plunger is pulled back by the spring closing the switch contacts, en-

FIGURE 9–17

Examples of types of solenoids.



energizing the circuit again, and the cycle repeats until the button is released.

A **solenoid** is similar to a relay (Figure 9–17). A coil, when energized, pulls a plunger that does some mechanical work. This is used on some door chimes where the plunger strikes a metal bar. It is also used on automotive starters. The plunger pulls the starter gear in to engage the flywheel to start the engine.

Phonograph pickups use the electromagnetic principle. A magnetic field is produced by a permanent magnet that is attached to a stylus (needle). The permanent magnet is placed inside a small coil. As the stylus is tracked through the groove of a record, it moves up and down and from side to side in response to the audio signal recorded. The movement of the magnet in the coil induces a small voltage that varies at the audio signal response. The induced voltage is then amplified and used to drive a loudspeaker, reproducing the audio signal.

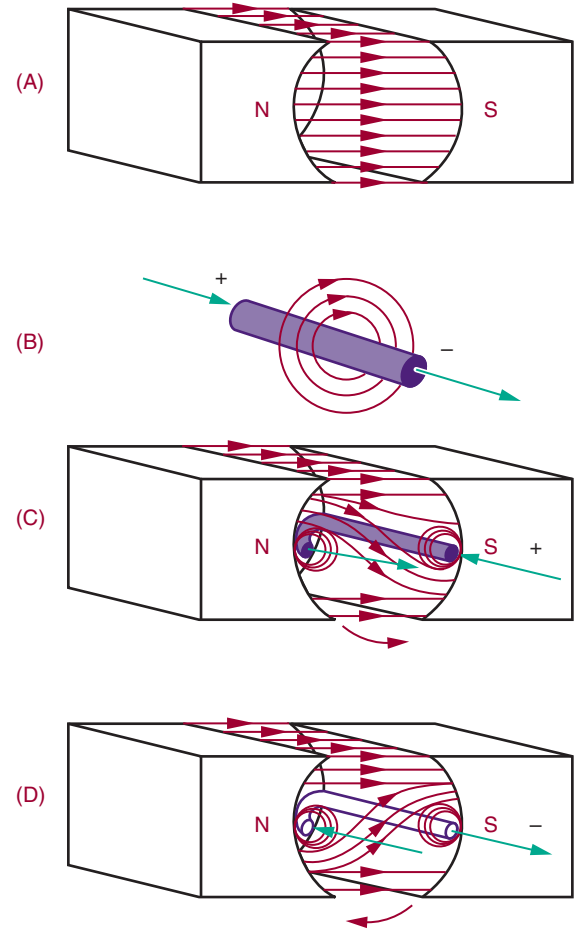
Loudspeakers are used for all types of audio amplification. Most speakers today are constructed of a moving coil around a permanent magnet. The magnet produces a stationary magnetic field. As current is passed through the coil, it produces a magnetic field that varies at the rate of the audio signal. The varying magnetic field of the coil is attracted and repelled by the magnetic field of the permanent magnet. The coil is attached to a cone that moves back and forth in response to the audio signal. The cone moving back and forth moves the air, reproducing the audio sound.

Magnetic recording is used for cassette recorders, video recorders, reel-to-reel recorders, floppy disk drives, and hard disk drives. All these devices use the same electromagnetic principle to store information. A signal is stored on the tape or disk with a record head, to be read back later with a playback head. In some equipment the record and playback head are combined in one package or they may be the same head. The record and playback head are a coil of wire with a ferromagnetic core. In a tiny gap between the ends of the core is a magnetic field. As the storage medium, a piece of material covered with iron oxide, is pulled across the record head, the magnetic field penetrates the type, magnetizing it. The information is written on it in a magnetic pattern that corresponds to the original information. To play back or read the information, the medium is moved past the gap in the playback head. The changing magnetic field induces a small voltage into the coil winding. When this voltage is amplified, the original information is reproduced.

The operation of a DC motor depends on the principle that a current-carrying conductor, placed in and at right angles to a magnetic field, tends to move at right angles to the direction of the field. Figure 9-18A shows a magnetic field extending between a north pole and south pole. Figure 9-18B shows the magnetic field that exists around a current-carrying conductor. The plus sign implies that the current flows inward. The direction of the flux lines can be determined using the left-hand rule. Figure 9-18C shows the conductor placed in the magnetic field. Note that both fields become distorted. Above the wire, the field is weakened, and the conductor tries to move upward. The amount of force exerted upward depends on the strength of the field between the poles and the amount of current flowing through the conductor. If the current through the conductor is reversed (Figure 9-18D), the direction of the magnetic flux around the conductor is reversed. If this occurs, the field below the conductor is weakened and the conductor tends to move downward.

FIGURE 9-18

Operation of a DC motor.



A method of determining the direction of a current-carrying conductor in a magnetic field uses the right-hand motor rule: When the thumb, index finger, and middle finger of the right hand are extended at right angles to each other, the middle finger points in the direction of current flow in the conductor; the index finger indicates the magnetic field from the north pole to the south pole; the thumb points in the direction of the motion of the conductor.

The force acting on a current-carrying conductor in a magnetic field depends on the strength

of the magnetic field, the length of the conductor, and the amount of current flowing in the conductor.

If a loop of wire, free to rotate horizontally, is placed between the two poles of a magnet, the loop spins as the poles repel each other. The current flows in one direction on one side of the loop and in the other direction on the other side of the loop. One side of the loop moves down and the other side of the loop moves upward. The loop rotates in a counterclockwise direction around its axis. A commutator reverses the direction of current flow in the loop every time it reaches the top or zero torque position. This is how a DC motor rotates. The loop or armature rotates in a magnetic field. Permanent magnets or electromagnets may produce this field. The commutator reverses the direction of current through the armature. Note the resemblance between a DC motor and a DC generator.

The basic meter movement uses the principle of the DC motor. It consists of a stationary permanent magnet and a moveable coil. When the current flows through the coil, the resulting magnetic field reacts with the field of the permanent magnet and causes the coil to rotate. The greater the current flow through the coil, the stronger the magnetic field produced. The stronger the magnetic field produced, the greater the rotation of the coil. To determine the amount of current flow, a pointer is attached to the rotating coil. As the coil turns, the pointer also turns. The pointer moves across a graduated scale and indicates the amount of current flow. This type of meter movement is used for analog meters such as voltmeters, ammeters, and ohmmeters.

A conductor carrying current can be deflected (moved) by a magnetic field. It is not the conductor that is deflected, but the electrons traveling in the conductor. The electrons are restricted to the conductor, so the conductor also moves. Electrons can travel through other media. In the case of television picture tubes, electrons travel through a vacuum to strike a phosphor screen where they

emit light. The electrons are produced by an electron gun. By varying the electron beam over the surface of the picture screen, a picture can be created. To move the beam back and forth across the screen, two magnetic fields deflect the beam. One magnetic field moves the beam up and down the screen and the other magnetic field moves the beam from side to side. This method is used in television, radar, oscilloscopes, computer terminals, and other applications where a picture is desired on a screen.

9-4 QUESTIONS

1. What are the differences between an AC and a DC generator?
2. Why are relays important?
3. How does a loudspeaker produce sound?
4. What is the principle behind DC motors and meter movements?
5. How does an electromagnetic field produce an image on a screen?

SUMMARY

- The word *magnet* is derived from the name of magnetite, a mineral that is a natural magnet.
- A magnet can be created by rubbing a piece of soft iron with another magnet.
- An electromagnet is created by current flowing in a coil of wire.
- Horseshoe, bar, rectangular, and ring are the most common shapes of magnets.
- Unlike poles attract and like poles repel.
- One theory of magnetism is based on the spin of electrons as they orbit around an atom.
- Another theory of magnetism is based on the alignment of domains.
- Flux lines are invisible lines of force surrounding a magnet.

- Flux lines form the smallest loop possible.
- Permeability is the ability of a material to accept magnetic lines of force.
- A magnetic field surrounds a wire when current flows through it.
- The direction of the flux lines around a wire can be determined by grasping the wire with the left hand, with the thumb pointing in the direction of current flow. The fingers then point in the direction of the flux lines.
- If two current-carrying wires are placed next to each other, with current flowing in the same direction, their magnetic fields combine.
- The strength of an electromagnet is directly proportional to the number of turns in the coil and the amount of current flowing through the coil.
- The polarity of an electromagnet is determined by grasping the coil with the left hand with the fingers in the direction of current flow. The thumb then points toward the north pole.
- *Retentivity* is the ability of a material to retain a magnetic field.
- Electromagnetic induction occurs when a conductor passes through a magnetic field.
- Faraday's law: Induced voltage is directly proportional to the rate at which the conductor cuts the magnetic lines of force.
- The left-hand rule for generators can be used to determine the direction of induced voltage.
- AC and DC generators convert mechanical energy into electrical energy.
- A relay is an electromechanical switch.
- Electromagnetic principles are applied in the design and manufacture of doorbells, solenoids, phonograph pickups, loudspeakers, and magnetic recordings.
- DC motors and meters use the same principles.
- Electron beams can be deflected by an electromagnetic field to produce images on television, radar, and oscilloscope screens.

CHAPTER 9 SELF-TEST

1. How can the domain theory of magnetism be verified?
2. What three methods can be used to increase the strength of an electromagnet?
3. Explain how a DC generator operates through one cycle.

Inductance

OBJECTIVES

After completing this chapter, the student should be able to:

- Explain the principles of inductance.
- Identify the basic units of inductance.
- Identify different types of inductors.
- Determine the total inductance in series and parallel circuits.
- Explain L/R time constants and how they relate to inductance.



See accompanying CD for interactive presentations and tutorials relating to Chapter 10.

When a current flows through a conductor, a magnetic field builds up around the conductor. This field contains energy and is the foundation for inductance.

This chapter examines inductance and its application to DC circuits. Inductance is covered in more detail in Chapter 16.

10-1 INDUCTANCE

Inductance is the characteristic of an electrical conductor that opposes a change in current flow. An *inductor* is a device that stores energy in a magnetic field.

Inductance exhibits the same effect on current in an electric circuit as inertia does on velocity of a mechanical object. It takes more work to

start a load moving than it does to keep it moving because the load possesses the property of inertia. Inertia is the characteristic of mass that opposes a change in velocity. Once current is moving through a conductor, inductance helps to keep it moving. The effects of inductance are sometimes desirable and other times undesirable.

As noted in Chapter 9, the basic principle behind inductance states, *when a current flows through a conductor, it generates a magnetic field around the conductor*. As the magnetic flux lines build up, they create an opposition to the flow of current.

When the current changes direction or stops, or the magnetic field changes, an electromotive force (emf) is induced back into the conductor through the collapsing of the magnetic field. The opposition to the changes in current flow is iden-

tified as counter electromotive force (counter emf). This effect is summarized by Lenz's law—an induced emf in any circuit is always in a direction to oppose the effect that produced it. The amount of counter emf is in proportion to the rate of change. The faster the rate of change, the greater the counter emf.

All conductors have some inductance. The amount of inductance depends on the conductor and the shape of it. Straight wire has small amounts of inductance whereas coils of wire have much more inductance.

The unit by which inductance is measured is the henry (H), named for Joseph Henry (1797–1878), an American physicist. A henry is the amount of inductance required to induce an emf of 1 volt when the current in a conductor changes at the rate of 1 ampere per second. The henry is a large unit; the millihenry (mH) and microhenry (μH) are more commonly used. The symbol for inductance is L .

10-1 QUESTIONS

1. Define *inductance*.
2. What is the unit for measuring inductance?
3. Define a *henry*.
4. What letter is used to represent inductance?

10-2 INDUCTORS

Inductors are devices designed to have a specific **inductance**. They consist of a conductor coiled around a core and are classified by the type of core material—magnetic or nonmagnetic. Figure 10-1 shows the symbol used for inductors.

Inductors can also be fixed or variable. Figure 10-2 shows the symbol for a variable inductor. Variable inductors are created with adjustable core material. Figure 10-3 shows several types of

FIGURE 10-1

Schematic symbol for an inductor.



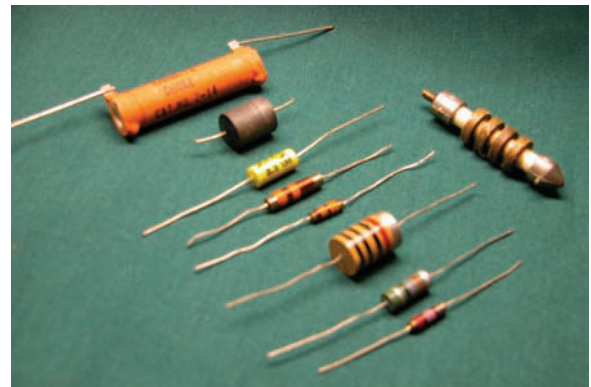
FIGURE 10-2

Schematic symbol for a variable inductor.

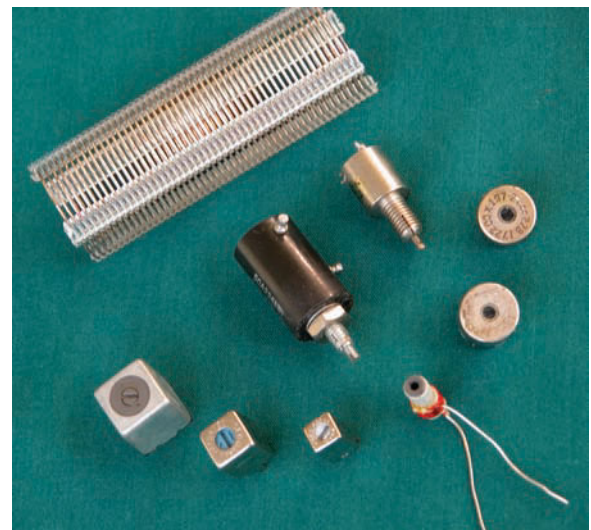


FIGURE 10-3

Several types of inductors used to vary the inductance.



FIXED INDUCTORS



VARIABLE INDUCTORS

FIGURE 10-4

An air-core inductor.



FIGURE 10-5

Schematic symbol for an iron-core inductor.



inductors used for adjusting the core material. Maximum inductance occurs when the core material is in line with the coil of the wire.

Air-core inductors, or inductors without core material, are used for up to 5 millihenries of inductance. They are wrapped on a ceramic or phenolic core (Figure 10-4).

Ferrite and powdered iron cores are used for up to 200 millihenries. The symbol used for an iron-core inductor is shown in Figure 10-5.

Toroid cores are donut-shaped and offer a high inductance for a small size (Figure 10-6). The magnetic field is contained within the core.

Shielded inductors have a shield made of magnetic material to protect them from the influence of other magnetic fields (Figure 10-7).

Laminated iron-core inductors are used for all large inductors (Figure 10-8). These inductors vary from 0.1 to 100 henries, the inductance depending on the amount of current flowing through the inductor. These inductors are sometimes referred to as *chokes*. They are used in the filtering circuits of power supplies to remove AC

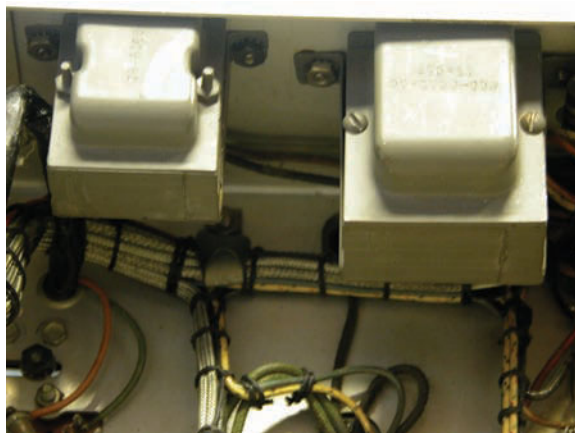
FIGURE 10-6

Toroid-core inductor.



FIGURE 10-7

Shielded inductor.

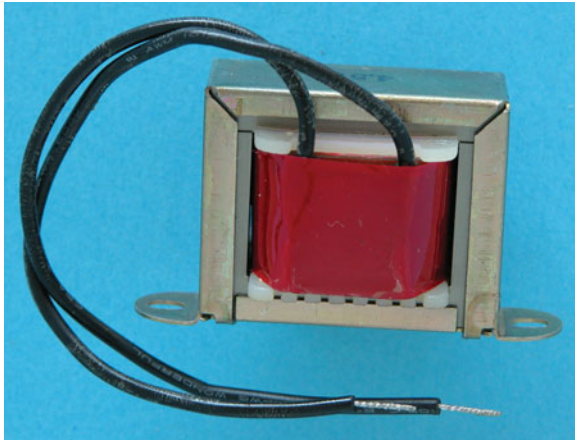


components from the DC output. They will be discussed further later on.

Inductors typically have tolerances of $\pm 10\%$, but tolerances of less than 1% are available. Inductors, like resistors, can be connected in series, parallel, or series-parallel combinations. The total inductance of several inductors connected in se-

FIGURE 10–8

Laminated iron-core inductor.



ries (separated to prevent their magnetic fields from interacting) is equal to the sum of the individual inductances.

$$L_T = L_1 + L_2 + L_3 \dots + L_n$$

If two or more inductors are connected in parallel (with no interaction of their magnetic fields) the total inductance is found by using the formula:

$$\frac{1}{L_T} = \frac{1}{L_1} + \frac{1}{L_2} + \frac{1}{L_3} \dots + \frac{1}{L_n}$$

10–2 QUESTIONS

1. What are inductors?
2. Draw the symbols used to represent fixed and variable inductors.
3. What is another name for a laminated iron-core inductor?
4. What are the formulas for determining total inductance in:
 - a. Series circuits?
 - b. Parallel circuits?

5. What is the total inductance of a circuit with three inductors, 10 H, 3.5 H, and 6 H, connected in parallel?

10–3 L/R TIME CONSTANTS

A **time constant** is the time required for current through a conductor to increase to 63.2% or decrease to 36.8% of the maximum current. An RL circuit is shown in Figure 10–9. L/R is the symbol used for the time constant of an RL circuit. This can be expressed as:

$$t = \frac{L}{R}$$

where: t = time in seconds

L = inductance in henries

R = resistance in ohms

Figure 10–10 charts the growth and decay (or increase and decrease) of a magnetic field, in terms of time constants. It takes five time constants to fully transfer all the energy into the magnetic field, or to build up the maximum magnetic field. It takes five full-time constants to completely collapse the magnetic field.

FIGURE 10–9

Circuit used to determine L/R time constant.

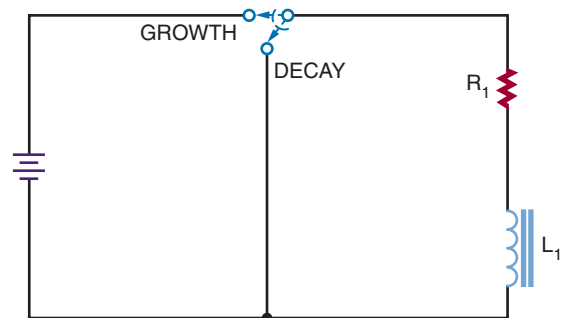
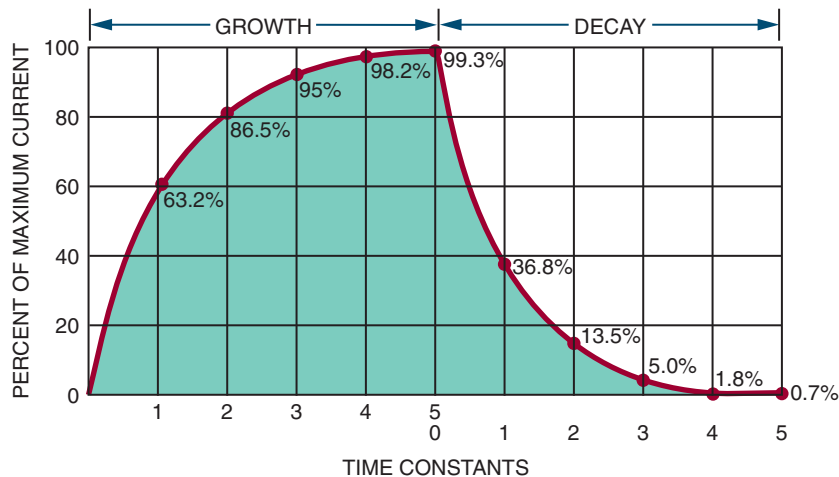


FIGURE 10-10

Time constants required to build up or collapse the magnetic field in an inductor.



10-3 QUESTIONS

1. What is a time constant for an inductor?
2. How is a time constant determined?
3. How many time constants are required to fully build up a magnetic field for an inductor?
4. How many time constants are required to fully collapse a magnetic field for an inductor?
5. How long does it take to fully build up a magnetic field for a 0.1-henry inductor in series with a 100,000-ohm resistor?

SUMMARY

- Inductance is the ability to store energy in a magnetic field.
- The unit for measuring inductance is the henry (H).
- The letter L represents inductance.

- Inductors are devices designed to have specific inductances.
- The symbol for fixed inductance is:



- The symbol for a variable inductor is:



- Types of inductors include: air core, ferrite or powdered iron core, toroid core, shielded, and laminated iron core.
- The total inductance for inductors connected in series is calculated by the formula:

$$L_T = L_1 + L_2 + L_3 \dots + L_n$$

- The total inductance for inductors connected in parallel is:

$$\frac{1}{L_T} = \frac{1}{L_1} + \frac{1}{L_2} + \frac{1}{L_3} \dots + \frac{1}{L_n}$$

- A time constant is the time required for current to increase to 63.2% or decrease to 36.8% of the maximum current.

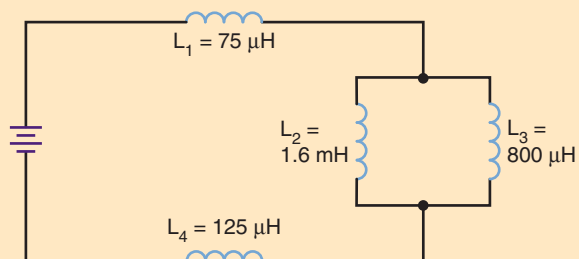
- A time constant can be determined by the formula:

$$t = \frac{L}{R}$$

- It takes five time constants to fully build up or collapse the magnetic field of an inductor.

CHAPTER 10 SELF-TEST

1. How can the magnetic field be increased for a particular inductance?
2. What is the total inductance for the circuit shown?
3. A 500-mH inductor and a 10-kilohm resistor are connected in series to a 25-volt source. What will be the voltage across the inductor 100 microseconds after energizing the circuit?



Capacitance

OBJECTIVES

After completing this chapter, the student should be able to:

- Explain the principles of capacitance.
- Identify the basic units of capacitance.
- Identify different types of capacitors.
- Determine total capacitance in series and parallel circuits.
- Explain RC time constants and how they relate to capacitance.



See accompanying CD for interactive presentations, tutorials and Capacitive examples in MultiSim, Chapter 11.

Capacitance allows for the storage of energy in an electrostatic field. Capacitance is present whenever two conductors are separated by an insulator.

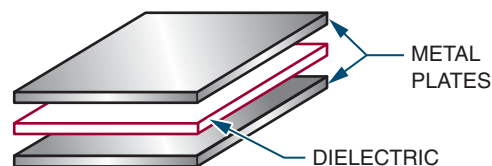
This chapter focuses on capacitance and its application to DC circuits. Capacitance is covered in more detail in Chapter 15.

11-1 CAPACITANCE

Capacitance is the ability of a device to store electrical energy in an electrostatic field. A **capacitor** is a device that possesses a specific amount of capacitance. A capacitor is made of two conductors separated by an insulator (Figure 11-1). The conductors are called *plates* and the insulator is called a *dielectric*. Figure 11-2 shows the symbols for capacitors.

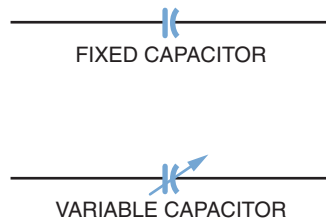
FIGURE 11-1

A capacitor consists of two plates (conductors) separated by a dielectric (insulator or nonconductor).



When a DC voltage source is connected to a capacitor, a current flows until the capacitor is charged. The capacitor is charged with an excess of electrons on one plate (negative charge) and a deficiency of electrons on the other plate (positive charge). The dielectric prevents electrons from moving between the plates. Once the capacitor is charged, all current stops. The

FIGURE 11-2
Schematic symbols for capacitors.



capacitor's voltage is equal to the voltage of the voltage source.

A charged capacitor can be removed from the voltage source and used as an energy source. However, as energy is removed from the capacitor, the voltage diminishes rapidly. In a DC circuit, a capacitor acts as an open circuit after its initial charge. An *open circuit* is a circuit with an infinite resistance.

CAUTION: BECAUSE A CAPACITOR CAN BE REMOVED FROM A VOLTAGE SOURCE AND HOLD THE POTENTIAL OF THE VOLTAGE SOURCE INDEFINITELY, TREAT ALL CAPACITORS AS THOUGH THEY WERE CHARGED. NEVER TOUCH BOTH LEADS OF A CAPACITOR WITH YOUR HAND UNTIL YOU HAVE DISCHARGED IT BY SHORTING BOTH LEADS TOGETHER. A CAPACITOR IN A CIRCUIT CAN HOLD A POTENTIAL INDEFINITELY IF IT DOES NOT HAVE A DISCHARGE PATH.

The amount of energy stored in a capacitor is in proportion to the size of the capacitor. The capacitors used in classrooms are usually small and deliver only a small shock if discharged through the body. If a capacitor is large and charged with a high voltage, however, the shock can be fatal. Charged capacitors should be treated like any other voltage source.

The basic unit of capacitance is the **farad** (F). A farad is the amount of capacitance that can store 1 coulomb (C) of charge when the capacitor is charged to 1 volt. The farad is too large for or-

dinary use, so the microfarad (μF) and picofarad (pF) are used. The letter *C* stands for capacitance.

$$1 \text{ microfarad} = 0.000,001 \text{ or } \frac{1}{1,000,000} \text{ farad}$$

$$1 \text{ picofarad} = 0.000,000,000,001 \text{ or}$$

$$\frac{1}{1,000,000,000,000} \text{ farad}$$

11-1 QUESTIONS

1. What is capacitance?
2. Draw the symbol for capacitance.
3. What precautions should be observed when handling capacitors?
4. What is the unit for measuring capacitance?
5. What units are normally associated with capacitors?

11-2 CAPACITORS

Four factors affect the capacitance of a capacitor. They are:

1. Area of the plate
2. Distance between the plates
3. Type of dielectric material
4. Temperature

A capacitor is either fixed or variable. A **fixed capacitor** has a definite value that cannot be changed. A **variable capacitor** is one whose capacitance can be changed either by varying the space between plates (trimmer capacitor) or by varying the amount of meshing between two sets of plates (tuning capacitor).

Capacitance is directly proportional to the area of the plate. For example, doubling the plate area doubles the capacitance if all other factors remain the same.

Capacitance is inversely proportional to the distance between the plates. In other words, as the plates move apart, the strength of the electric field between the plates decreases.

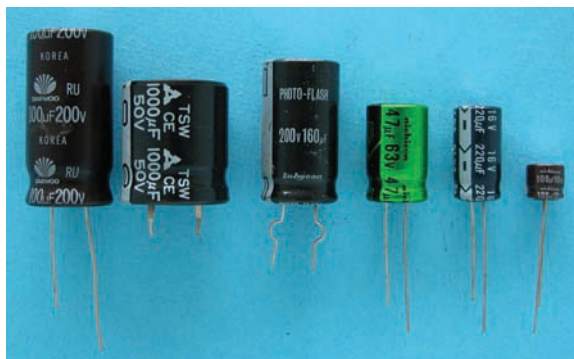
The ability of a capacitor to store electrical energy depends on the electrostatic field between the plates and the distortion of the orbits of the electrons in the dielectric material. The degree of distortion depends on the nature of dielectric material and is indicated by its dielectric constant. A *dielectric constant* is a measure of the effectiveness of a material as an insulator. The constant compares the material's ability to distort and store energy in an electric field to the ability of air, which has a dielectric constant of 1. Paper has a dielectric constant of 2 to 3; mica has a dielectric constant of 5 to 6; and titanium has a dielectric constant of 90 to 170.

The temperature of a capacitor is the least significant of the four factors. It need not be considered for most general-purpose applications.

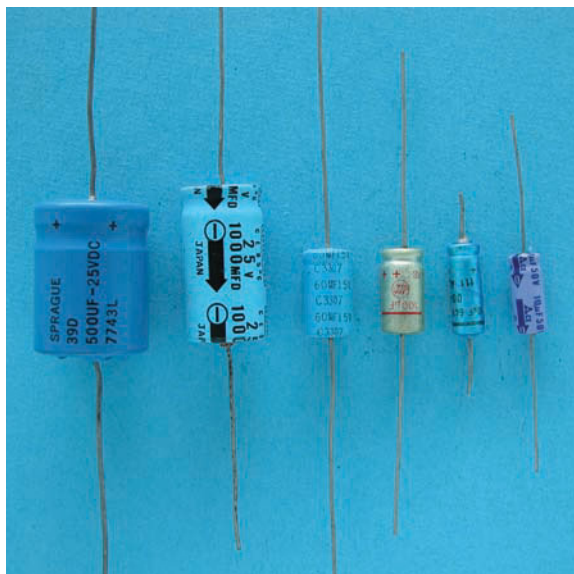
Capacitors come in many types and styles to meet the needs of the electronics industry. *Electrolytic capacitors* offer large capacitance for small size and weight (Figure 11-3). Electrolytic capacitors consist of two metal foils separated by fine gauze or other absorbent material that is saturated with a chemical paste called an *electrolyte*. The electrolyte is a good conductor and serves as part of the negative plate. The dielectric is formed by oxidation of the positive plate. The oxidized layer is thin and a good insulator. An electrolytic capacitor is polarized, having a positive and negative lead. Polarity must be observed when connecting an electrolytic capacitor in a circuit.

Paper and plastic capacitors are constructed by a rolled foil technique (Figure 11-4). A paper dielectric has less resistance than a plastic film dielectric, and plastic film is now being used more as a result. The plastic film allows a metallized film to be deposited directly on it. This reduces the distance between plates and produces a smaller capacitor.

FIGURE 11-3
Electrolytic capacitors.



RADIAL CAPACITOR LEAD



AXIAL CAPACITOR LEADS

The ceramic disk capacitor is popular because it is inexpensive to produce (Figure 11-5). It is used for capacitors of 0.1 microfarad and smaller. The ceramic material is the dielectric. This is a tough, reliable, general-purpose capacitor.

Variable capacitors also come in all sizes and shapes (Figure 11-6). Types include padders, trimmers, and tuning capacitors. Padder and trimmer capacitors must be adjusted by a technician. Tuning capacitors can be adjusted by the user.

FIGURE 11-4
Paper and plastic capacitors.

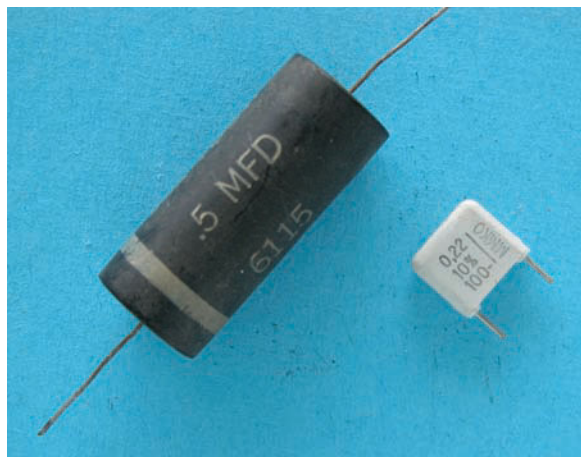
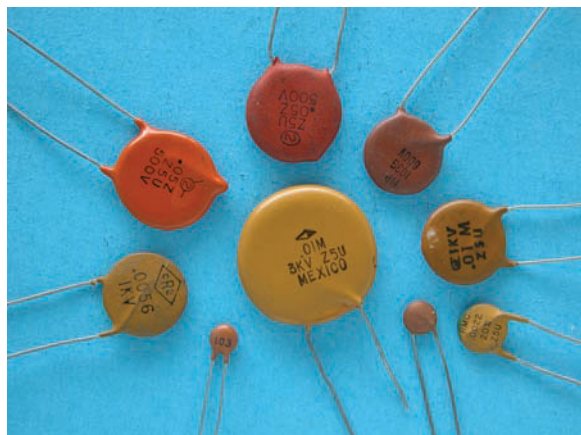
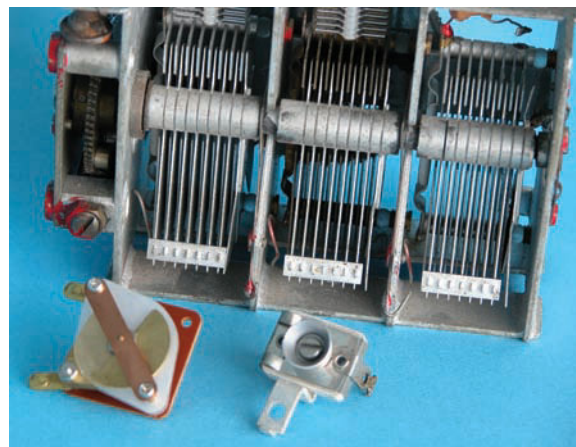


FIGURE 11-5
Ceramic disk capacitors.



Like resistors and inductors, capacitors can be connected in series, parallel, and series-parallel combinations. Placing capacitors in series effectively increases the thickness of the dielectric. This decreases the total capacitance, because capacitance is inversely proportional to the distance between the plates. The total capacitance of capacitors in series is calculated like the total resistance of parallel resistors:

FIGURE 11-6
Variable capacitors.



$$\frac{1}{C_T} = \frac{1}{C_1} + \frac{1}{C_2} + \frac{1}{C_3} \dots + \frac{1}{C_n}$$

When capacitors of different values are connected in series, the smaller capacitors charge up to the highest voltage.

Placing capacitors in parallel effectively adds to the plate area. This makes the total capacitance equal to the sum of the individual capacitances:

$$C_T = C_1 + C_2 + C_3 \dots + C_n$$

Capacitors in parallel all charge to the same voltage.

11-2 QUESTIONS

1. What four factors affect capacitance?
2. What are the advantages of electrolytic capacitors?
3. What are other names for variable capacitors?
4. What is the formula for total capacitance in series circuits?
5. What is the formula for total capacitance in parallel circuits?

11-3 RC TIME CONSTANTS

An RC time constant reflects the relationship between time, resistance, and capacitance. An RC circuit is shown in Figure 11-7. The time it takes a capacitor to charge and discharge is directly proportional to the amount of the resistance and capacitance. The time constant reflects the time required for a capacitor to charge up to 63.2% of the applied voltage or to discharge down to 36.8%. The time constant is expressed as:

$$t = RC$$

where: t = time in seconds

R = resistance in ohms

C = capacitance in farads

EXAMPLE: What is the time constant of a 1-microfarad capacitor and a 1-megohm resistor?

Given:

$$C = 1 \mu\text{F}$$

$$R = 1 \text{ M}\Omega$$

$$t = ?$$

Solution:

$$t = RC$$

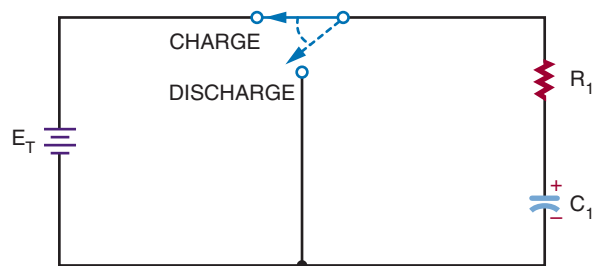
$$t = (1,000,000)(0.000001)$$

$$t = 1 \text{ second}$$

The time constant is not the time required to charge or discharge a capacitor fully. Figure 11-8

FIGURE 11-7

Circuit used to determine RC time constant.



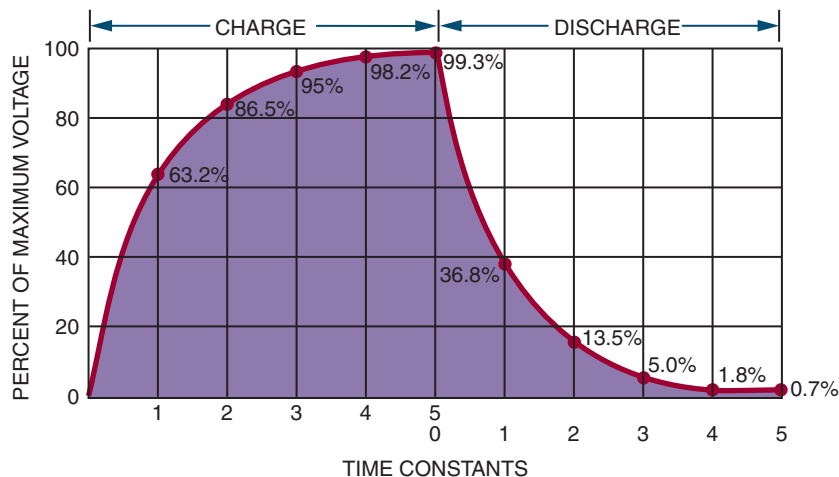
shows the time constants needed to charge and discharge a capacitor. Note that it takes approximately five time constants to fully charge or discharge a capacitor.

11-3 QUESTIONS

1. What is a time constant for a capacitor?
2. How is the time constant determined for a capacitor?
3. How many time constants are required to fully charge or discharge a capacitor?

FIGURE 11-8

Chart of time constants required to charge and discharge a capacitor.



4. A 1-microfarad and a 0.1-microfarad capacitor are connected in series. What is the total capacitance for the circuit?
5. A 0.015-microfarad capacitor is charged to 25 volts. What is the voltage 25 milliseconds after placing a 2-megohm resistor across its terminals?

SUMMARY

- Capacitance is the ability to store electrical energy in an electrostatic field.
- A capacitor consists of two conductors separated by an insulator.
- The symbol for a fixed capacitor is:



- The symbol for a variable capacitor is:



- The unit of capacitance is the farad (F).
- Because the farad is large, microfarads (μF) and picofarads (pF) are more often used.
- The letter C represents capacitance.
- Capacitance is affected by:
 1. Area of the capacitor plates
 2. Distance between the plates
 3. Types of dielectric materials
 4. Temperature
- Capacitor types include: electrolytic, paper, plastic, ceramic, and variable.
- The formula for total capacitance in a series circuit is:

$$\frac{1}{C_T} = \frac{1}{C_1} + \frac{1}{C_2} + \frac{1}{C_3} \dots + \frac{1}{C_n}$$

- The formula for total capacitance in a parallel circuit is:

$$C_T = C_1 + C_2 + C_3 \dots + C_n$$

- The formula for the RC circuit time constant is:

$$t = RC$$

- It takes five time constants to fully charge and discharge a capacitor.

CHAPTER 11 SELF-TEST

1. Where is the charge stored in a capacitor?
2. Four capacitors are connected in series, 1.5 μF , 0.05 μF , 2000 pF, and 25 pF. What is the total capacitance of the circuit?
3. Four capacitors are connected in parallel, 1.5 μF , 0.05 μF , 2000 pF, and 25 pF. What is the total capacitance of the circuit?

SECTION ACTIVITIES

The section activities are provided to support material covered in the five sections of the textbook. Always observe all safety precautions provided by your instructor and included with components. When using power and hand tools always follow all safety rules for each piece of equipment. Never use a tool for a purpose other than what it was intended for. Always wear safety glasses in the lab area.

Prior to starting a project it is important to complete the following:

- Obtain all parts.
- Develop a time line on how long it will take to finish the project. (Be realistic.)
- Review all safety precautions.
- Breadboard the circuit prior to the making of the printed circuit board. Breadboarding involves the assembling of the circuit using a specially designed board.
- Lay out a printed circuit board using the guidelines in Chapter 38.

SECTION 1 ACTIVITY—DC CIRCUITS

1. Design a voltage divider using series and parallel circuits. Prior to building, use MultiSim to verify that the circuit works. Assemble the circuit using a printed circuit board and test and compare results with MultiSim.
2. Design and build a simple DC motor using magnets and enamel-coated copper wire.
3. Design and build a tester that can measure the voltage of several different types of cells and batteries.
4. Design and build a circuit for determining unknown resistor values.
5. Design and build a circuit that takes advantage of a capacitor charging and/or discharging.

SECTION 2

AC Circuits



Career Profile

Gemma Barnhart



TITLE

Electronic Assembler

COMPANY

DRS Training and Control Systems

BACKGROUND

Gemma was hired at DRS Training and Control Systems when she responded to a want ad in her local newspaper. At the time she had no formal education or experience in electronic assembly, but she was willing to learn. Before beginning her new job as an electronic assembler, Gemma first had to complete in-house technical training provided by her company. Gemma completed a course in soldering and another in crimping—two critical skills for electronic assemblers. She then completed her company's course to be a "Certified Electronics Assembler." In this course she learned more advanced assembly skills including blueprint reading, measuring, and assembly-related mathematics. Her math instruction focused on using both regular and decimal fractions—a math skill that is important in making accurate measurements. Gemma has worked at DRS Training and Control Systems for more than nine years. With her training and experience, she is now able to conduct in-process inspections on various electronic assemblies and wire harnesses.

JOB REQUIREMENTS

Technical certificate in electronic assembly

ON THE JOB

In her daily work, Gemma assembles various electronic components that become part of larger subassemblies and assemblies. She also builds wire harnesses for power supplies and other electromechanical devices. Her job involves reading blueprints, selecting electronic components based on the blueprints, soldering and crimping to make the components part of a subassembly or an assembly, making measurements, and inspecting work in progress to make sure that all processes and procedures have been accomplished properly.

UPSIDE

Gemma finds her work very fulfilling and likes the potential for career advancement it affords her. She is currently enrolled in an Associate of Science Degree Program that is offered on-site at DRS Training and Control Systems in partnership with a local college. She also likes knowing that her work is important—that the products she assembles will be used to support the military in our country's national defense.

DOWNSIDE

People who want to work in this field must be able to work under the pressure of deadlines. Like most companies, DRS Training and Control Systems receives contracts that have deadlines. This means that electronic assemblers such as Gemma and all other personnel must be able to meet deadlines. This requires you to be focused, stay on task, and be well organized.

OPPORTUNITIES

We live in an electronic world. Consequently, opportunities abound for people who want to work in this field and who either have the requisite training or are willing to complete it. Electromechanical manufacturing companies are always looking for skilled personnel to work as electronic assemblers.

WORDS OF ADVICE

If you want to work in this field, you should develop a positive attitude, learn to read blueprints, and complete skills training in soldering and crimping. It is also important to learn how to use fractions and how to make accurate measurements.

Alternating Current

OBJECTIVES

After completing this chapter, the student should be able to:

- Describe how an AC voltage is produced with an AC generator (alternator).
- Define *alternation*, *cycle*, *hertz*, *sine wave*, *period*, and *frequency*.
- Identify the parts of an AC generator (alternator).
- Define *peak*, *peak-to-peak*, *effective*, and *rms*.
- Explain the relationship between time and frequency.
- Identify and describe three basic nonsinusoidal waveforms.
- Describe how nonsinusoidal waveforms consist of the fundamental frequency and harmonics.
- Understand why AC is used in today's society.
- Describe how an AC distribution system works.

There are two types of electricity used to perform work, such as lighting bulbs or running motors. **Direct current (DC)**, as its name implies, is a current that flows in one direction only. Batteries develop this type of energy. The second type of energy used today to perform useful work is **alternating current (AC)**. Unlike its converse, direct current, the direction of alternating current flow reverses with regularity.

Today, alternating current is the most used method to transmit electrical energy from one location to another. This was not the case in the late

1800s. Thomas Edison utilized direct current. His vision of electrified cities incorporated the idea of many small, DC-generating stations scattered about in the community because there was no way to change or alter direct current to recoup transmission losses. This limited DC's usefulness to local small areas and prohibited its usefulness in transmitting electrical energy over long distances.

In 1888 a young engineer discovered rotating magnetic fields and their potential for the practical generation and transmission of electrical energy that made the electrification of the United

States and the rest of the world possible. The power lines that crisscross the cities and countryside are a testament to his genius. The father of alternating current and our electrified world was Nikola Tesla.

This chapter examines the reasons alternating current is important, the methods by which it is generated, and its important electrical characteristics.

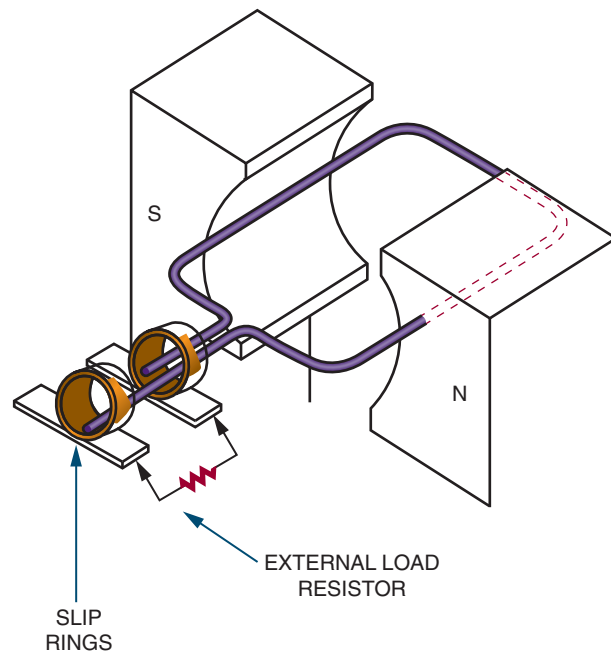
12-1 GENERATING ALTERNATING CURRENT

An AC generator converts mechanical energy into electrical energy. The AC generator is capable of producing an alternating voltage by utilizing the principles of electromagnetic induction. Electromagnetic induction is the process of inducing a voltage in a conductor by passing it through a magnetic field.

As described in Chapter 9, the left-hand rule for generators can be used to determine the direction of current flow in a conductor that is being passed through a magnetic field: When the thumb is pointed in the direction of the conductor movement, the index finger (extended at right angles to the thumb) indicates the direction of the magnetic lines of flux from north to south, and the middle finger (extended at a right angle to the index finger) indicates the direction of current flow in the conductor. Maximum voltage is induced when the conductor is moved perpendicular to the lines of flux. When the conductor is moved parallel to the lines of flux, no voltage is induced.

Figure 12-1A-F shows a wire loop being rotated through a magnetic field. In position B, the loop is parallel to the lines of force. As previously stated, no voltage is induced when the conductor is moved parallel to the lines of force. As the loop is rotated to position C, it passes through more lines of force, and the maximum voltage is in-

FIGURE 12-1A
Basic AC generator (alternator).



duced when the loop is at right angles to the lines of force. As the loop continues to rotate to position D, fewer lines of force are cut and the induced voltage decreases. Movement from position B to position D represents a rotation of 180 degrees. Rotating the loop to position E results in a reversal of current flow. Again, the maximum voltage is induced when the loop is at right angles to the lines of force. As the loop returns to its original position at F, the induced voltage returns to zero.

Each time an AC generator moves through one complete revolution, it is said to complete one *cycle*. Its output voltage is referred to as one cycle of output voltage. Similarly, the generator produces one cycle of output current in a complete circuit. The two halves of a cycle are referred to as **alternations** (Figure 12-2). Each alternation is produced by a change in the polarity of the volt-

FIGURE 12-1B-F

AC generator inducing a voltage output.

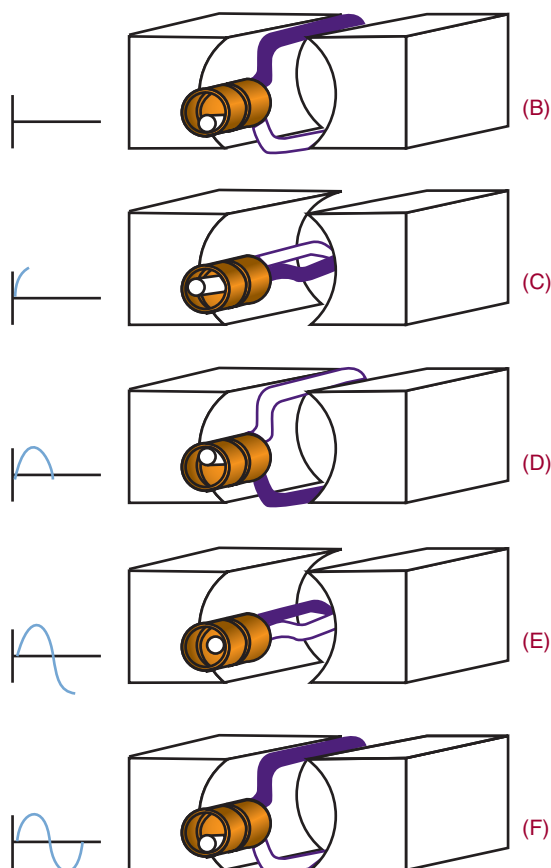
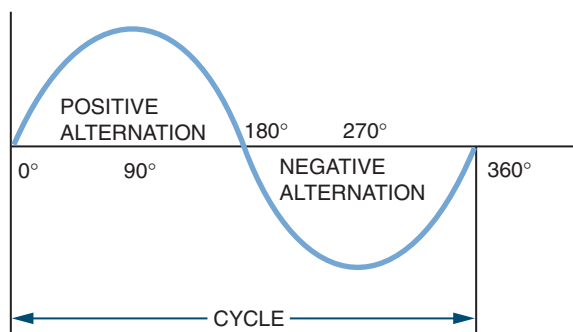


FIGURE 12-2

Each cycle consists of a positive and a negative alternation.



age. The voltage exhibits one polarity during half the cycle (one alternation) and the opposite polarity during half the cycle (second alternation). Generally, one alternation is referred to as the positive alternation and the other as the negative alternation. The positive alternation produces output with a positive polarity; the negative alternation produces output with a negative polarity. Two complete alternations of voltage with no reference to time make up a **cycle**. One cycle per second is defined as a **hertz** (Hz).

The rotating loop of wire is referred to as the armature. The AC voltage that is induced in the rotating armature is removed from the ends of the loop by a sliding contact located at each end of the armature (Figure 12-3). Two metal rings, called slip rings, are attached to each end of the loop. Brushes slide against the slip rings to remove the AC voltage. The AC generator described generates a low voltage. To be practical, an AC generator must be made of many loops to increase the induced voltage.

The waveform produced by an AC generator is called a *sinusoidal waveform* or *sine wave* for short (Figure 12-4). The sine wave is the most basic and widely used of all the AC waveforms. It can be produced by both mechanical and electronic methods. The sine wave is identical to the trigonometric sine function. The values of a sine

FIGURE 12-3

Voltage is removed from the armature of an AC generator through slip rings.

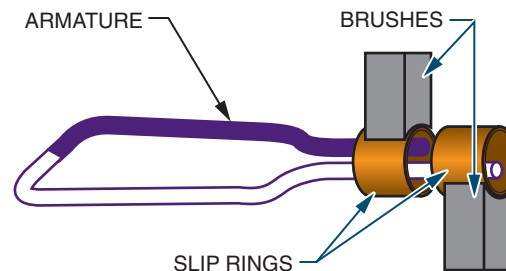
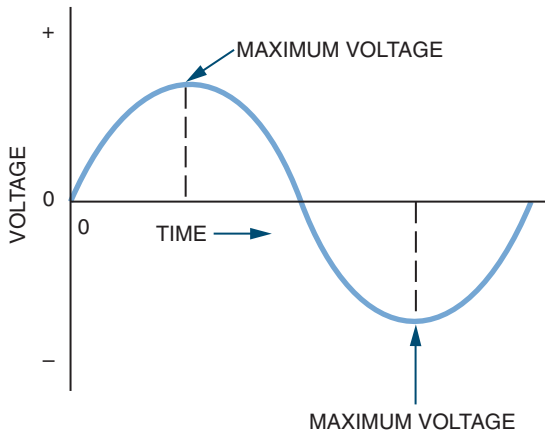


FIGURE 12-4

The sinusoidal waveform, the most basic of the AC waveforms.



wave vary from zero to maximum in the same manner as the sine value. Both voltage and current exist in sine-wave form.

12-1 QUESTIONS

1. What is the function of an AC generator?
2. Explain how an AC generator operates.
3. Define the following terms:
 - a. Cycle
 - b. Alternation
 - c. Hertz
 - d. Sine wave
4. Identify the major parts of an AC generator.
5. What is the difference between a positive and a negative alternation?
6. Would it be possible to design an AC generator whose armature generates the magnetic field and rotates, thus inducing an AC current in stationary coils placed around it?

12-2 AC VALUES

Each point on a sine wave has a pair of numbers associated with it. One value expresses the degree of rotation of the waveform. The **degree of rotation** is the angle to which the armature has turned. The second value indicates its amplitude. **Amplitude** is the maximum departure of the value of an alternating current or wave from the average value. There are several methods of expressing these values.

The **peak value** of a sine wave is the absolute value of the point on the waveform with the greatest amplitude (Figure 12-5). There are two peak values, one for the positive and one for the negative alternation. These peak values are equal.

The **peak-to-peak value** refers to the vertical distance between the two peaks (Figure 12-6). The peak-to-peak value can be determined by adding the absolute values of each peak.

The **effective value** of alternating current is the amount that produces the same degree of heat in a given resistance as an equal amount of direct current. The effective value can be determined by

FIGURE 12-5

The peak value of a sine wave is the point on the AC waveform having the greatest amplitude. The peak value occurs during both the positive and the negative alternations of the waveform.

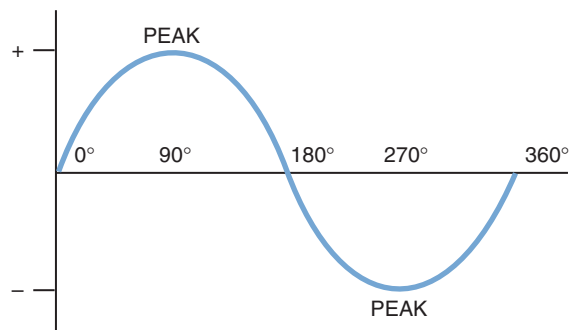
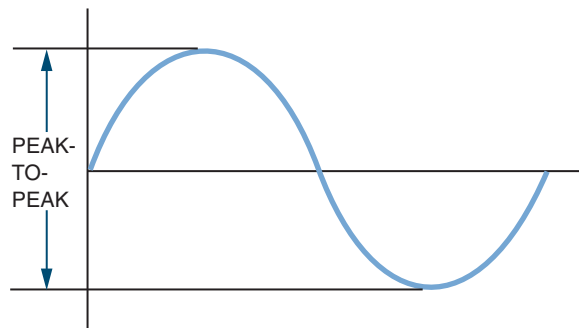


FIGURE 12-6

The peak-to-peak value can be determined by adding the peak values of the two alternations.



a mathematical process called the root-mean-square (rms) process. Therefore, the effective value is also referred to as the **rms value**. Using the rms process shows that the effective value of a sine wave is equal to 0.707 times the peak value. When an AC voltage or current is given or measured, it is assumed to be the effective value unless otherwise indicated. Most meters are calibrated to indicate the effective, or rms, value of voltage and current.

$$E_{\text{rms}} = 0.707E_p$$

where: E_{rms} = rms or effective voltage value
 E_p = maximum voltage of one alternation

$$I_{\text{rms}} = 0.707I_p$$

where: I_{rms} = rms or effective current value
 I_p = maximum current of one alternation

EXAMPLE: A current sine wave has a peak value of 10 amperes. What is the effective value?

Given:
 $I_{\text{rms}} = ?$
 $I_p = 10 \text{ A}$

Solution:
 $I_{\text{rms}} = 0.707I_p$
 $I_{\text{rms}} = (0.707)(10)$
 $I_{\text{rms}} = 7.07 \text{ A}$

EXAMPLE: A voltage sine wave has an effective value of 40 volts. What is the peak value of the sine wave?

Given:
 $E_p = ?$
 $E_{\text{rms}} = 40 \text{ V}$

Solution:
 $E_{\text{rms}} = 0.707E_p$
 $40 = 0.707E_p$
 $56.58 \text{ V} = E_p$

The time required to complete one cycle of a sine wave is called the **period**. The period is usually measured in seconds. The letter t is used to represent the period.

The number of cycles that occurs in a specific period of time is called the **frequency**. The frequency of an AC sine wave is usually expressed in terms of cycles per second. The unit of frequency is the **hertz**. One hertz equals one cycle per second.

The period of a sine wave is inversely proportional to its frequency. The higher the frequency, the shorter the period. The relationship between the frequency and the period of a sine wave is expressed as:

$$f = \frac{1}{t}$$

$$t = \frac{1}{f}$$

where: f represents the frequency, and t represents the period.

EXAMPLE: What is the frequency of a sine wave with a period of 0.05 second?

Given:
 $f = ?$

$t = 0.05 \text{ second}$

Solution:
 $f = \frac{1}{t}$
 $f = \frac{1}{0.05}$
 $f = 20 \text{ Hz}$

EXAMPLE: If a sine wave has a frequency of 60 hertz, what is its period?

Given:

$$f = 60 \text{ Hz}$$

$$t = ?$$

Solution:

$$t = \frac{1}{f}$$

$$t = \frac{1}{60}$$

$$t = 0.0167 \text{ second} \\ \text{or } 16.7 \text{ msec}$$

12-2 QUESTIONS

- Define the following values:
 - peak
 - peak-to-peak
 - effective
 - rms
- A voltage sine wave has a peak value of 125 volts. What is its effective value?
- What is the relationship between time and frequency?
- A current sine wave has an effective value of 10 amperes. What is its peak value?
- What is the period of a 400-hertz sine wave?

12-3 NONSINUSOIDAL WAVEFORMS

The sine wave is the most common AC waveform. However, it is not the only type of waveform used in electronics. Waveforms other than sinusoidal (sine wave) are classified as nonsinusoidal. Nonsinusoidal waveforms are generated by specially designed electronic circuits.

Figures 12-7 through 12-9 show three of the basic nonsinusoidal waveforms. These waveforms can represent either current or voltage. Figure 12-7 shows a square wave, so designated because its positive and negative alternations are square in shape. This indicates that the current

FIGURE 12-7

Square waveform.

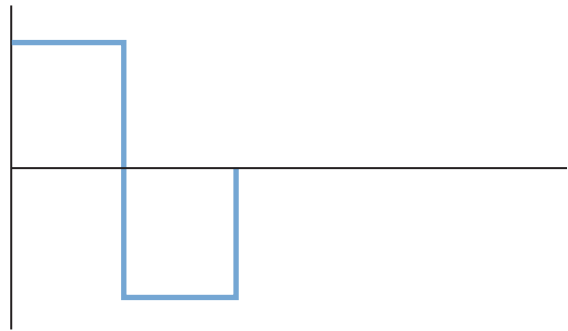
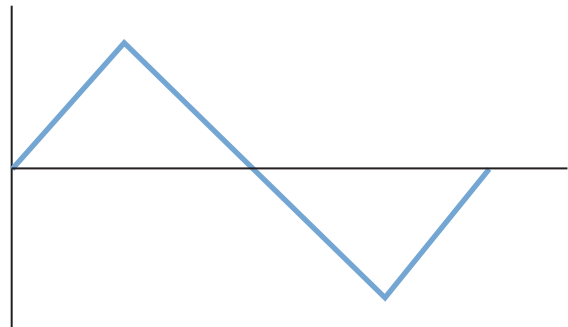


FIGURE 12-8

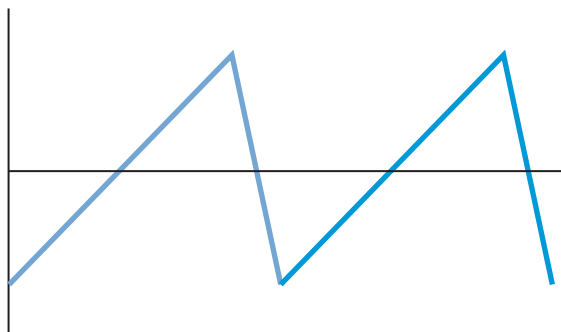
Triangular waveform.



or voltage immediately reaches its maximum value and remains there for the duration of the alternation. When the polarity changes, the current or voltage immediately reaches the opposite peak value and remains there for the next duration. The pulse width is equal to one-half the period. The **pulse width** is the duration the voltage is at its maximum or peak value until it drops to its minimum value. The amplitude can be any value. The square wave is useful as an electronic signal because its characteristics can be changed easily.

Figure 12-8 shows a triangular waveform. It consists of positive and negative ramps of equal

FIGURE 12-9
Sawtooth waveform.



slope. During the positive alternation the waveform rises at a linear rate from zero to its peak value and then decreases back to zero. During the negative alternation the waveform declines in the negative direction at a linear rate to peak value and then returns to zero. The period of this waveform is measured from peak to peak. Triangular waveforms are used primarily as electronic signals.

Figure 12-9 shows a sawtooth waveform. A sawtooth waveform is a special case of the triangular wave. First it rises at a linear rate and then rapidly declines to its negative peak value. The positive ramp is of relatively long duration and has a smaller slope than the short ramp. Sawtooth waves are used to trigger the operations of electronic circuits. In television sets and oscilloscopes they are used to sweep the electron beam across the screen, creating the image.

Pulse waveforms and other nonsinusoidal waveforms can be considered in two ways. One method considers the waveform as a momentary change in voltage followed, after a certain time interval, by another momentary change in voltage. The second method considers the waveform as the algebraic sum of many sine waves having different frequencies and amplitudes. This method is useful in the design of amplifiers. If the amplifier cannot pass all the sine-wave frequencies, distortion results.

Nonsinusoidal waves are composed of the fundamental frequency and harmonics. The **fundamental frequency** represents the repetition rate of the waveform. **Harmonics** are higher-frequency sine waves that are exact multiples of the fundamental frequency. *Odd harmonics* are frequencies that are odd multiples of the fundamental frequency. *Even harmonics* are frequencies that are even multiples of the fundamental frequency.

Square waves are composed of the fundamental frequency and all odd harmonics.

Triangular waveforms are also composed of the fundamental frequency and all odd harmonics, but unlike the square wave, the odd harmonics are 180 degrees out of phase with the fundamental frequency.

Sawtooth waveforms are composed of both even and odd harmonics. The even harmonics are 180 degrees out of phase with the odd harmonics.

12-3 QUESTIONS

1. What are nonsinusoidal waveforms?
2. Draw two cycles of a:
 - a. Square wave
 - b. Triangular wave
 - c. Sawtooth wave
3. What are the applications of these nonsinusoidal waveforms?
4. Describe the fundamental frequency and harmonics of three different nonsinusoidal waveforms.

SUMMARY

- AC is the most commonly used type of electricity.
- AC consists of current flowing in one direction and then reversing and flowing in the opposite direction.

- One revolution of an AC generator is called a cycle.
- The two halves of a cycle are referred to as alternations.
- Two complete alternations with no reference to time make up a cycle.
- One cycle per second is defined as a hertz.
- The waveform produced by an AC generator is called a sinusoidal waveform or sine wave.
- The peak value of a sine wave is the absolute value of the point on the waveform with the greatest amplitude.
- The peak-to-peak value is the vertical distance from one peak to the other peak.
- The effective value of AC is the amount of current that produces the same degree of heat in a given resistance as an equal amount of direct current.
- The effective value can be determined by a mathematical process called the root-mean-square (rms) process.
- The rms value of a sine wave is equal to 0.707 times the peak value.

$$E_{\text{rms}} = 0.707E_p$$

$$I_{\text{rms}} = 0.707I_p$$

- The time required to complete one cycle of a sine wave is called the period (t).
- The number of cycles occurring in a specific period of time is called frequency (f).
- The relationship between frequency and period is:

$$f = \frac{1}{t}$$

- Square waves are composed of the fundamental frequency and all odd harmonics.
- Triangular waveforms are composed of the fundamental frequency and all odd harmonics 180 degrees out of phase with the fundamental frequency.
- Sawtooth waveforms are composed of both even and odd harmonics, the even harmonics being 180 degrees out of phase with the odd harmonics.

CHAPTER 12 SELF-TEST

1. What causes magnetic induction to occur?
2. Explain how the left-hand rule applies to AC generators.
3. Explain how the peak-to-peak value of a waveform is determined.
4. How is the effective value of alternating current determined?
5. Draw examples of three nonsinusoidal waveforms that can represent current and voltage.
6. Why are harmonics important in the study of waveforms?

AC Measurements

OBJECTIVES

After completing this chapter, the student should be able to:

- Identify the types of meters available for AC measurements.
- Identify the types of meter movements used to make AC measurements.
- Explain the function of an oscilloscope.
- Identify the basic parts of an oscilloscope and explain their functions.
- Demonstrate the proper setup of an oscilloscope.
- Describe how to use an oscilloscope to take a measurement.
- Explain how a counter works.
- Identify the basic parts of a counter.

AC measurements of current, voltage, resistance, power, and frequency are necessary to operate and repair AC circuits and equipment.

This chapter covers some of the important test equipment used to take various AC measurements.

13-1 AC METERS

The *moving coil* meter movement is referred to as the d'Arsonval meter movement. The analog meter (Figure 13-1) is a moving coil meter. The easy-to-read digital meter (Figure 13-2) has recently replaced the analog meter.

Moving coil meters are designed to measure DC current. To measure AC current on this meter the AC current must first be converted to DC current. This is accomplished with diodes called *rectifiers*. The process of converting AC to DC is called **rectification**. The rectifiers are placed between the meter input and the meter movement and allow current to flow in only one direction (Figure 13-3). The rectifiers convert the sine wave into a pulsating DC current that is applied to the meter movement.

A second type of AC meter uses the iron-vane meter movement (Figure 13-4). This does not require the conversion of AC to DC. It consists of

FIGURE 13-1

Analog meter used for AC measurements.



FIGURE 13-3

Rectifiers are used to convert the AC signal to a DC level prior to applying it to the meter movement.

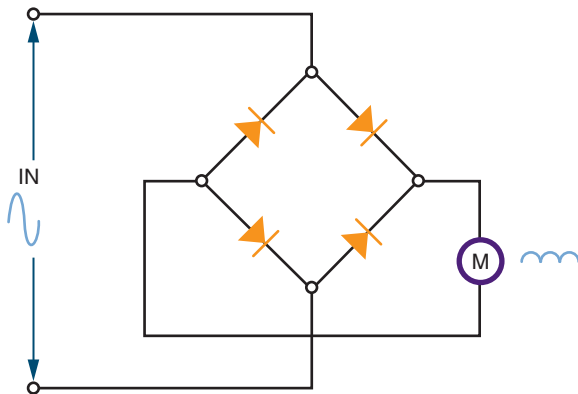


FIGURE 13-2

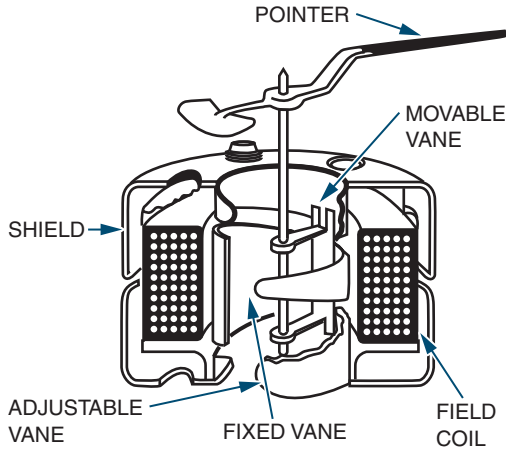
Digital meter used for AC measurements.



two iron vanes located within a coil. One vane is stationary and the other is movable. A pointer is attached to the movable vane and moves proportionally to the current passing through the coil.

FIGURE 13-4

Iron-vane meter movements do not require the conversion of AC to DC.



The magnetic field of the coil induces a north and south pole into the iron vanes. Because like poles repel and both vanes have the same polarity, they move away from each other. The iron-vane movement requires more current for a full-scale deflection than does the moving coil meter movement. For this reason, iron-vane movements find little application in low-power circuits. The iron-vane movement is also inaccurate for frequencies above 100 hertz. It is used primarily for 60-hertz applications.

The clamp-on meter is based on the principle that an AC current flowing in a conductor causes a magnetic field to expand and collapse as the current increases and decreases in value (Figure 13-5). Each time the AC current changes polarity, the magnetic field changes direction. The clamp-on AC meter uses a split-core transformer. This allows the core to be opened and placed around the conductor. At the end of the core is a coil, which is cut by the magnetic lines of force. This induces a voltage into the coil, creating a flow of alternating current. This AC current must be rectified before being sent to the meter movement, generally a moving coil. This type of me-

FIGURE 13-5

A clamp-on meter operates on the principle that current flowing through a wire generates a magnetic field around the wire.



ter is used for measuring high values of AC current. The current in the conductor must be large in order to produce a magnetic field strong enough to induce a current flow in the core of the meter.

The basic AC meter movement is a current-measuring device. However, this type of meter movement can also be used to measure AC voltage and power. Because alternating current changes direction periodically, the meter leads can be hooked into an AC circuit in either direction.

CAUTION: THE METER MUST BE CONNECTED IN SERIES WITH THE CIRCUIT WHEN MEASURING CURRENT. WHEN MEASURING VOLTAGE, THE METER MUST ALWAYS BE CONNECTED IN PARALLEL.

ALWAYS BE SURE THE CURRENT OR VOLTAGE BEING MEASURED IS WITHIN THE RANGE OF THE METER. FOR ADDITIONAL PROTECTION, ALWAYS START AT THE HIGHEST SCALE AND WORK DOWN TO THE APPROPRIATE SCALE.

13-1 QUESTIONS

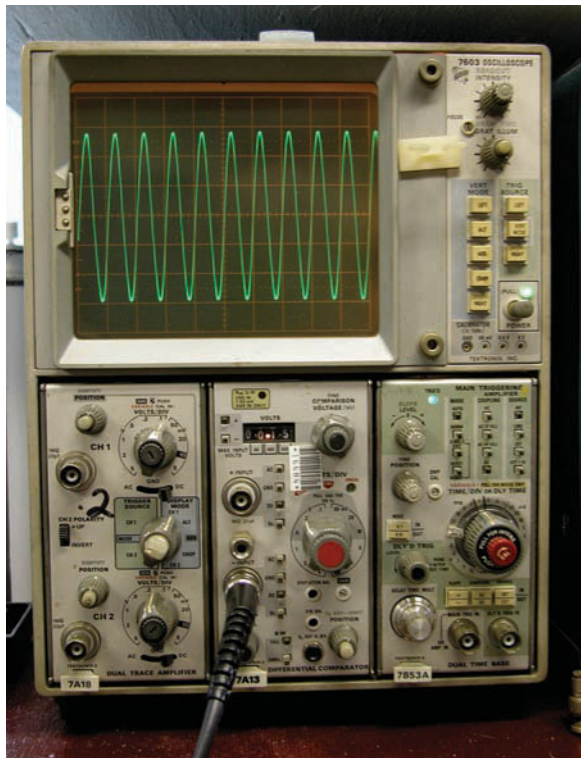
1. How is a d'Arsonval meter movement used to measure an AC voltage?
2. What makes an iron-vane meter movement desirable for measuring an AC signal?
3. Explain the principle behind a clamp-on AC meter.
4. Draw a circuit showing how to connect an AC ammeter.
5. Describe the proper procedure for using an AC voltmeter in a circuit. (Include switch settings where possible).

13-2 OSCILLOSCOPES

An **oscilloscope** is the most versatile piece of test equipment available for working on electronic equipment and circuits (Figure 13-6). It provides a visual display of what is occurring in the circuit.

FIGURE 13-6

An oscilloscope is the most versatile piece of test equipment available to a technician.



An oscilloscope is capable of providing the following information about an electronic circuit:

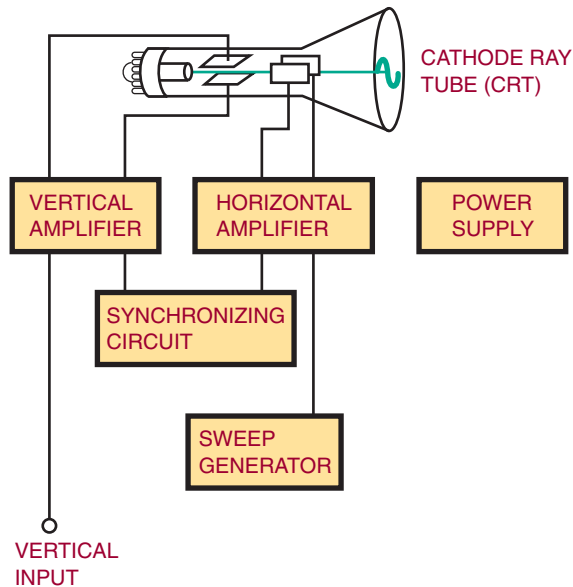
1. The frequency of a signal
2. The duration of a signal
3. The phase relationship between signal waveforms
4. The shape of a signal's waveform
5. The amplitude of a signal

The basic parts of an oscilloscope are: a cathode-ray tube (CRT), a sweep generator, horizontal and vertical deflection amplifiers along with their synchronizing circuits, and power supplies (Figure 13-7).

The sweep generator provides a sawtooth waveform as input to the horizontal deflection

FIGURE 13-7

Block diagram of the basic parts of an oscilloscope.



amplifier. The horizontal and vertical deflection amplifiers increase the amplitude of the input voltage to the proper level for deflection of the electron beam in the cathode-ray tube. The power supply provides DC voltages to operate the amplifiers and cathode-ray tube.

The cathode-ray tube consists of three parts: a phosphor screen, deflection plates, and an electron gun (Figure 13-8). The phosphor screen emits light when struck by electrons. The electron gun generates the electron beam that strikes the screen. As the electron beam approaches the screen, the deflection plates change the direction of the electron beam as it approaches the screen. The horizontal deflection plate is attached to the sweep generator, which moves the electron beam back and forth across the screen. The vertical amplifier is connected to the input signal and controls its amplitude.

Using a faceplate that has been marked in centimeters along both a vertical and a horizontal

FIGURE 13-8

Basic parts of a cathode-ray tube (CRT).

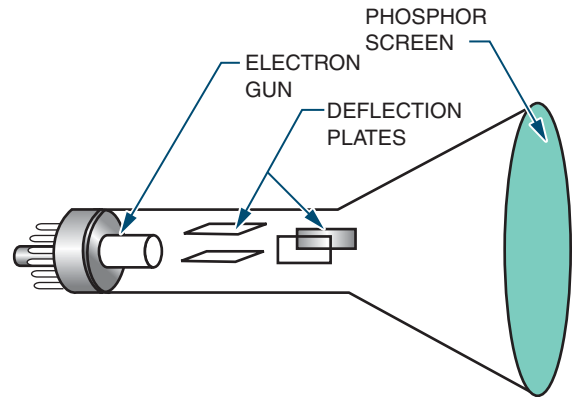
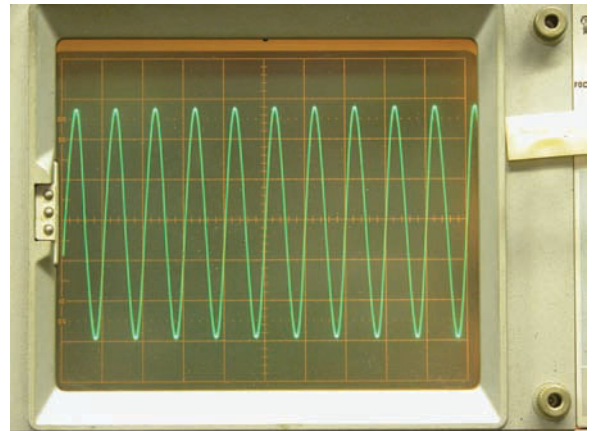


FIGURE 13-9

Oscilloscope faceplate.



axis (Figure 13-9), the oscilloscope can be calibrated with a known voltage prior to testing an unknown signal. Then, when the unknown signal is applied, its amplitude can be calculated. Rather than mark the actual faceplate of the CRT, oscilloscopes are provided with separate faceplates called *graticules* that are mounted in front of the CRT.

The power switch of an oscilloscope is usually located on the front panel (Figure 13-10). It may

FIGURE 13–10
Oscilloscopes vary in the number of front panel controls.



be a toggle, push-button, or rotary switch. It may be mounted separately or mounted with another switch. Its purpose is to apply line voltage to operate the oscilloscope.

The intensity (also called brightness) switch is used to control the electron beam within the CRT. It is a rotary control and allows the operator to adjust the electron beam for proper viewing.

CAUTION: KEEP THE BRIGHTNESS AS LOW AS POSSIBLE. TOO MUCH INTENSITY, FOR TOO LONG A TIME, CAN BURN A HOLE OR ETCH A LINE IN THE PHOSPHOR SCREEN, RUINING THE CRT.

The focus and astigmatism controls are connected to the electron gun and are used to adjust the electron beam size and shape before it reaches the deflection plates. Both of these controls are rotary controls. To use them, the electron beam is slowly swept across the screen of the CRT and both controls are alternately adjusted until a per-

fectly round dot is obtained. On some newer oscilloscopes the astigmatism control may be recessed below the front panel.

The horizontal and vertical position controls are also rotary controls. They allow the electron beam to be positioned anywhere on the face of the CRT. They are initially set so that the electron beam sweeps across the center of the CRT. They are then adjusted to place the electron beam in a position to measure amplitude and time by its placement on a graticule.

The vertical block consists of a vertical input jack, and AC/DC switch, and a volts/cm rotary switch. The oscilloscope probe is connected to the input jack. The probe is then connected to the circuit to be tested. The AC/DC switch allows the signal to be sent directly to the vertical amplifier in the DC position or to a capacitor in the AC position. The capacitor in the AC position is used to block any DC component on the signal being checked. The volts/cm switch is used to adjust the amplitude of the input signal. If the signal is too large, the vertical amplifier distorts it. If the signal is too small, it is amplified. This control is calibrated to match the CRT faceplate. Where this control is set depends on the amplitude of the signal on the CRT.

The horizontal block, also referred to as the time base, consists of a time/cm rotary switch, a trigger-control switch, and a triggering level control. The time/cm switch sets the horizontal sweep rate that is to be represented by the horizontal graduations. The lower the setting, the fewer cycles per second are displayed. The trigger-control switch selects the source and polarity of the trigger signal. The trigger source can be line, internal, or external. The polarity can be positive or negative. When line is selected as the trigger source, the power-line frequency of 60 hertz is used as the trigger frequency. When internal (INT) is selected as the trigger frequency, the input-signal frequency is used as the trigger frequency. External (EXT) allows a trigger frequency from an external source to be used.

The level control sets the amplitude that the triggering signal must exceed before the sweep generator starts. If the level control is in the AUTO position, the oscilloscope is free running. Turning the level control results in a blank screen when no signal is present. The level control is turned to a point where the trace on the oscilloscope goes out, and then turned back to where the trace reappears. At this point, a stable presentation is on the screen. By using the triggering and level controls together to synchronize the sweep generator with the input signal, a stable trace can be obtained on the CRT.

Prior to use, the oscilloscope should be checked to determine that it is not faulty. Misadjusted controls can give false readings. Most oscilloscopes have a built-in test signal for setup. Initially the controls should be set in the following positions:

Intensity, Focus, Astigmatism, and Position controls (set to the center of their range):

Triggering:	INT +
Level:	AUTO
Time/cm:	1 msec
Volts/cm:	0.02
Power:	ON

The oscilloscope probe should be connected to the test jack of the voltage calibrator. A square wave should appear on the trace of the CRT. The display should be stable and show several cycles at the amplitude indicated by the voltage calibrator. The oscilloscope can now be used.

To use the oscilloscope, set the volts/cm selector switch to its highest setting. Connect the input signal to be observed, and rotate the volts/cm selector switch until the display is approximately two-thirds of the screen's height. Adjust the time-base controls to produce a stable trace and to select the desired number of cycles.

13-2 QUESTIONS

1. What can be learned about a waveform by using an oscilloscope?
2. What are the basic parts of an oscilloscope?
3. Describe a basic procedure for setting up an oscilloscope prior to its initial use.
4. What are applications of an oscilloscope when working with a circuit?
5. What does the graticule marked on the screen of the oscilloscope represent?

13-3 FREQUENCY COUNTERS

A **frequency counter** (Figure 13-11) measures frequency by comparing a known frequency against an input frequency. All frequency counters consist of the same basic sections: a time base, an input-signal conditioner, a gate-control circuit, a main gate, a decade counter, and a display (Figure 13-12).

The signal conditioner converts the input signal to a waveshape and amplitude compatible

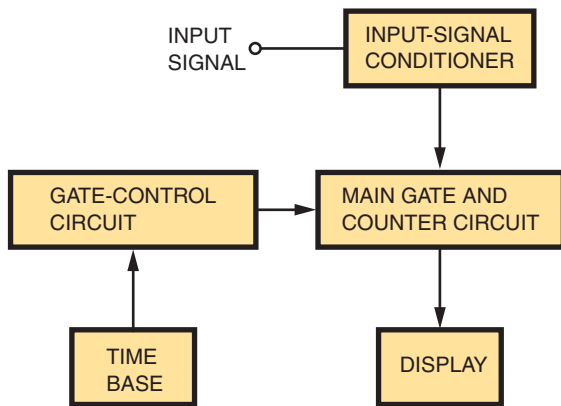
FIGURE 13-11

A frequency counter is used widely in repair shops and industry.



FIGURE 13-12

Block diagram of an electronic counter.



with the circuitry in the counter. The main gate passes the conditioned input signal to the counter circuit if a signal from the time base is present at the same time. The time base drives the gate-control circuit, using a signal compatible with the signal being measured. The gate control acts as the synchronization center of the counter. It controls the opening and closing of the main gate and also provides a signal to latch (lock onto) the count at the end of the counting period and reset the circuitry for the next count. The decade counter keeps a running tally of all the pulses that pass through the main gate. One decade counter is required for each digit displayed. The display, which provides a visual readout of the frequency being measured, can be of several types. The more common displays are gas-discharge tubes, light-emitting diode displays, and liquid-crystal displays.

The electronic counter was once a piece of laboratory equipment but is now used in electronics repair shops, engineering departments, ham-radio shacks, and on industrial production lines. The wide use of the counter can be attributed to the integrated circuit, which has reduced the size and price of the counter while increasing its accuracy, stability, reliability, and frequency range. (Integrated circuits are discussed in Section 3.)

13-3 QUESTIONS

1. What is the function of an electronic counter?
2. What are the basic sections of a counter?
3. Draw and label a block diagram of an electronic counter.
4. What is the function of the signal conditioner in a counter?
5. Why has the counter increased in popularity?

13-4 BODE PLOTTERS

Bode plots were originated and named for H. W. Bode, who used the plots for studying amplifier feedback. The original plots required semilog graph paper. Two graphs were required, one for gain in decibels plotted against frequency on the log scale and the other for phase shift in degrees plotted against frequency on the log scale. The arrival of computer simulations such as Electronic Workbench's MultiSIM has resulted in greater utilization of Bode plotters.

The **Bode plotter** in MultiSIM allows the user to produce a graph of a circuit's frequency response and is quite useful in analyzing filter circuits. The plotter measures a signal's voltage gain or phase shift. When the plotter is attached to a circuit, a frequency-amplitude and phase-angle analysis is performed.

The Bode plotter generates a range of frequencies over a specified spectrum. An AC source must be present somewhere in the circuit for it to work. The frequency of the AC source does not affect the plotter.

The Bode plotter measures the ratio of magnitudes (voltage gain in decibels) between two points ($V+$ and $V-$). It also measures the phase shift (in degrees) between two points.

A logarithmic base is used when the compared values have a large range, which is typical when analyzing frequency response. The horizontal or x -axis always shows frequency in Hertz.

When measuring the voltage gain, the vertical or y -axis shows the ratio of the circuit's output voltage to its input voltage. The units are in decibels. When measuring phase, the vertical axis always shows the phase angle in degrees.

13-4 QUESTIONS

1. What is the function of a Bode plotter?
2. What are the two graphs that a Bode plotter generates?
3. What is required to use the Bode plotter?
4. What units must the input magnitude be in?
5. With both graphs, what does the horizontal axis represent?

SUMMARY

- To measure AC current or voltage on a moving coil meter, the current or voltage must first be converted to DC.

- Iron-vane meter movement does not require conversion to DC.
- A clamp-on AC meter is based on the principle that current flowing through a wire generates a magnetic field.
- An oscilloscope provides the following information about a circuit:
 - Frequency of the signal
 - Duration of the signal
 - Phase relationships between signal waveforms
 - Shape of the signal's waveform
 - Amplitude of the signal
- The basic parts of an oscilloscope are:
 - Cathode-ray tube
 - Sweep generator
 - Horizontal deflection amplifier
 - Vertical deflection amplifier
 - Power supply
- A counter measures frequency by comparing an unknown frequency to a known frequency.
- The basic parts of a frequency counter are:
 - Time base
 - Input-signal conditioner
 - Gate-control circuit
 - Main gate
 - Decade counter
 - Display
- A bode plotter produces a graph of a circuit frequency response.

CHAPTER 13 SELF-TEST

1. Describe how a DC meter can be adapted to measure an AC signal.
2. Explain how a clamp-on ammeter is used for measuring current.
3. What type of information does an oscilloscope provide?
4. Describe the process for examining an oscilloscope to determine if it is operating properly.
5. Identify and describe the function of each of the major blocks of a counter.
6. What has been the major factor in bringing the counter to the workbench of repair shops?
7. Describe how a Bode plotter is connected to a circuit to measure magnitude.

Resistive AC Circuits

OBJECTIVES

After completing this chapter, the student shall be able to:

- Describe the phase relationship between current and voltage in a resistive circuit.
- Apply Ohm's law to AC resistive circuits.
- Solve for unknown quantities in series AC resistive circuits.
- Solve for unknown quantities in parallel AC resistive circuits.
- Solve for power in AC resistive circuits.

The relationship of current, voltage, and resistance is similar in DC and AC circuits. The simple AC circuit must be understood before moving on to more complex circuits containing capacitance and inductance.

14-1 BASIC AC RESISTIVE CIRCUITS

A basic AC circuit (Figure 14-1) consists of an AC source, conductors, and a resistive load. The AC source can be an AC generator or a circuit that generates an AC voltage. The resistive load can be a resistor, a heater, a lamp, or any similar device.

When an AC voltage is applied to the resistive load, the AC current's amplitude and direction vary in the same manner as those of the applied

FIGURE 14-1

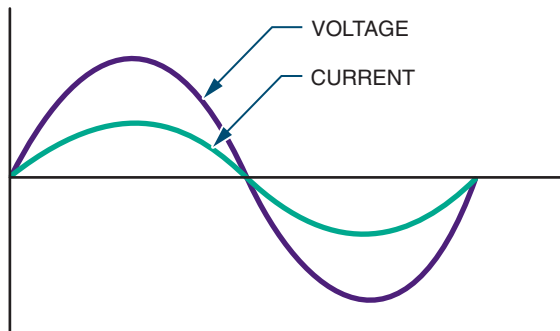
A basic AC circuit consists of an AC source, conductors, and a resistive load.



voltage. When the applied voltage changes polarity, the current also changes. They are said to be **in phase**. Figure 14-2 shows the in-phase relationship that exists between the current and the applied voltage in a pure resistive circuit. The current and voltage waveforms pass through zero and maximum values at the same time. However, the two waveforms do not have the same peak

FIGURE 14-2

The voltage and current are in phase in a pure resistive circuit.



amplitudes because they represent different quantities, measured in different units.

The AC current flowing through the resistor varies with the voltage and the resistance in the circuit. The current at any instant can be determined by applying Ohm's law.

Effective values are used in most measurements. As stated previously, the effective value is the amount of AC voltage that produces the same degree of heat as a DC voltage of the same value. The effective value can be considered the DC equivalent value. Ohm's law can be used with effective AC values, just as with DC values, in a pure resistive circuit.

EXAMPLE: If a circuit has an AC voltage source of 120 volts and a resistance of 1000 ohms, what is the effective current in the circuit? (Remember, an AC voltage or current is assumed to be effective unless otherwise specified.)

Given:

$$I = ?$$

$$E = 120 \text{ V}$$

$$R = 1000 \ \Omega$$

Solution:

$$I = \frac{E}{R}$$

$$I = \frac{120}{1000}$$

$$I = 0.12 \text{ A}$$

EXAMPLE: If an effective current of 1.7 amperes flows through a 68-ohm resistor, what is the effective value of the applied voltage?

Given:

$$I = 1.7 \text{ A}$$

$$E = ?$$

$$R = 68 \ \Omega$$

Solution:

$$I = \frac{E}{R}$$

$$1.7 = \frac{E}{68}$$

$$E = 115.60 \text{ V}$$

14-1 QUESTIONS

1. What is the phase relationship between current and voltage in a pure resistive circuit?
2. What AC value is used for most measurements?
3. What is the effective current in a circuit of $10,000 \ \Omega$ with 12 V applied?
4. What is the voltage (rms) of a circuit with 250 mA flowing through $100 \ \Omega$?
5. What is the resistance of a circuit when $350 \ \mu\text{A}$ are produced with an AC voltage of 12 V?

14-2 SERIES AC CIRCUITS

The current in a resistive circuit depends on the applied voltage. The current is always in phase with the voltage regardless of the number of resistors in the circuit. At any point in the circuit, the current has the same value.

Figure 14-3 shows a simple series circuit. The current flow is the same through both resistors. Using Ohm's law, the voltage drop across each resistor can be determined. The voltage drops added together equal the applied voltage.

FIGURE 14-3

Simple series AC circuit.

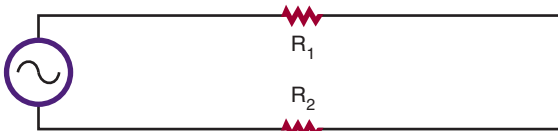


Figure 14-4 shows the phase relationships of the voltage drops, the applied voltage, and the current in the circuit. All the voltages and the current are in phase with one another in a pure resistive circuit.

EXAMPLE: If an AC circuit has an effective value of 120 volts applied across two resistors ($R_1 = 470$ ohms and $R_2 = 1000$ ohms), what is the voltage drop across each resistor?

Given:

$$R_1 = 470 \Omega$$

$$R_2 = 1000 \Omega$$

$$E_{R_1} = ?$$

$$E_{R_2} = ?$$

$$E_T = 120 \text{ V}$$

Solution:

First, find the total resistance (R_T).

$$R_T = R_1 + R_2$$

$$R_T = 470 + 1000$$

$$R_T = 1470 \Omega$$

Using R_T , now find the total current (I_T).

$$I_T = \frac{E_T}{R_T}$$

$$I_T = \frac{120}{1470}$$

$$I_T = 0.082 \text{ A}$$

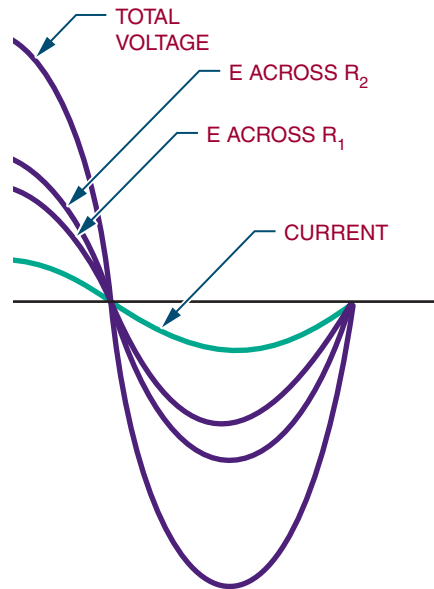
In a series circuit, $I_T = I_{R_1} = I_{R_2}$

$$\therefore I_{R_1} = 0.082 \text{ A}$$

$$I_{R_2} = 0.082 \text{ A}$$

FIGURE 14-4

The in-phase relationship of the voltage drops, applied voltage, and current in a series AC circuit.



Use I_1 to find the voltage drop across resistor R_1 .

$$I_{R_1} = \frac{E_{R_1}}{R_1}$$

$$0.082 = \frac{E_{R_1}}{470}$$

$$E_{R_1} = 38.54 \text{ V}$$

Use I_2 to find the voltage drop across resistor R_2 .

$$I_{R_2} = \frac{E_{R_2}}{R_2}$$

$$0.082 = \frac{E_{R_2}}{1000}$$

$$E_{R_2} = 82 \text{ V}$$

The voltage drop across each resistor is the effective voltage drop.

14-2 QUESTIONS

1. What is the voltage drop across two resistors, 22 kilohms and 47 kilohms, connected in series with 24 volts applied?
2. What is the voltage drop across the following series resistors:
 - a. $E_T = 100 \text{ V}$, $R_1 = 680 \Omega$, $R_2 = 1200 \Omega$
 - b. $E_T = 24 \text{ V}$, $R_1 = 22 \text{ k}\Omega$, $R_2 = 47 \text{ k}\Omega$
 - c. $I_T = 250 \text{ mA}$, $R_1 = 100 \Omega$, $R_2 = 500 \Omega$
 - d. $R_T = 10 \text{ k}\Omega$, $I_{R_1} = 1 \text{ mA}$, $R_2 = 4.7 \text{ k}\Omega$
 - e. $E_T = 120 \text{ V}$, $R_1 = 720 \Omega$, $I_{R_2} = 125 \text{ mA}$

14-3 PARALLEL AC CIRCUITS

The voltage in a parallel circuit (Figure 14-5) remains constant across each individual branch. However, the total current divides among the individual branches. In a parallel AC circuit, the total current is in phase with the applied voltage (Figure 14-6). The individual currents are also in phase with the applied voltage.

All current and voltage values are the effective values. These values are used the same way DC values are used.

EXAMPLE: If an AC circuit has an effective voltage of 120 volts applied across two parallel resistors of 470 ohms and 1000 ohms, respectively, what is the current flowing through each of the resistors?

FIGURE 14-5

A simple parallel AC circuit.

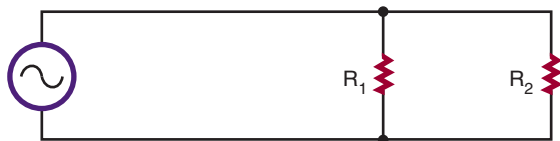
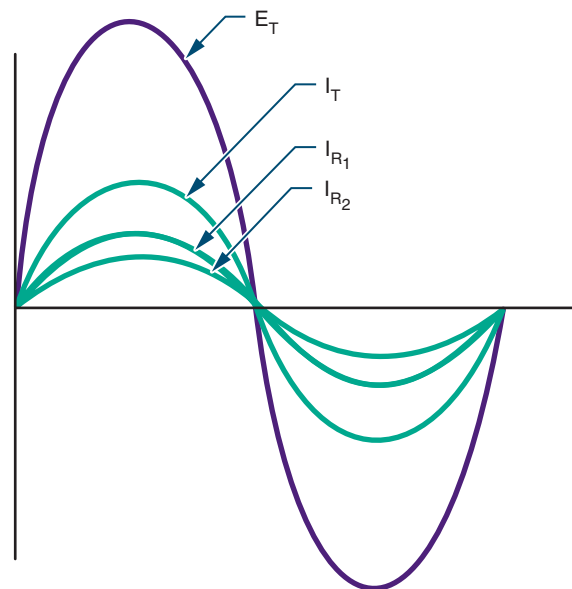


FIGURE 14-6

The in-phase relationship of the applied voltage, total current, and individual branch currents in a parallel AC circuit.



Given:

$$\begin{aligned} I_{R_1} &= ? \\ I_{R_2} &= ? \\ E_T &= 120 \text{ V} \\ R_1 &= 470 \Omega \\ R_2 &= 1000 \Omega \end{aligned}$$

Solution:

In a parallel circuit $E_T = E_{R_1} = E_{R_2}$

$$\begin{aligned} \therefore E_{R_1} &= 120 \text{ V} \\ E_{R_2} &= 120 \text{ V} \end{aligned}$$

Use E_1 to find the current through resistor R_1 .

$$\begin{aligned} I_{R_1} &= \frac{E_{R_1}}{R_1} \\ I_{R_1} &= \frac{120}{470} \\ I_{R_1} &= 0.26 \text{ A or } 260 \text{ mA} \end{aligned}$$

Use E_2 to find the current through resistor R_2 .

$$I_{R_2} = \frac{E_{R_2}}{R_2}$$

$$I_{R_2} = \frac{120}{1000}$$

$$I_{R_2} = 0.12 \text{ A or } 120 \text{ mA}$$

14-3 QUESTION

1. What is the current flow through the following parallel AC resistive circuits?

a. $E_T = 100 \text{ V}$, $R_1 = 470 \ \Omega$, $R_2 = 1000 \ \Omega$

b. $E_T = 24 \text{ V}$, $R_1 = 22 \text{ k}\Omega$, $R_2 = 47 \text{ k}\Omega$

c. $E_T = 150 \text{ V}$, $R_1 = 100 \ \Omega$, $R_2 = 500 \ \Omega$

d. $I_T = 0.0075 \text{ A}$, $E_{R_1} = 10 \text{ V}$, $R_2 = 4.7 \text{ k}\Omega$

e. $R_T = 4700 \ \Omega$, $I_{R_1} = 11 \text{ mA}$, $E_{R_2} = 120 \text{ V}$

14-4 POWER IN AC CIRCUITS

Power is dissipated in AC resistive circuits the same way as in DC resistive circuits. Power is measured in watts and is equal to the current times the voltage in the circuit.

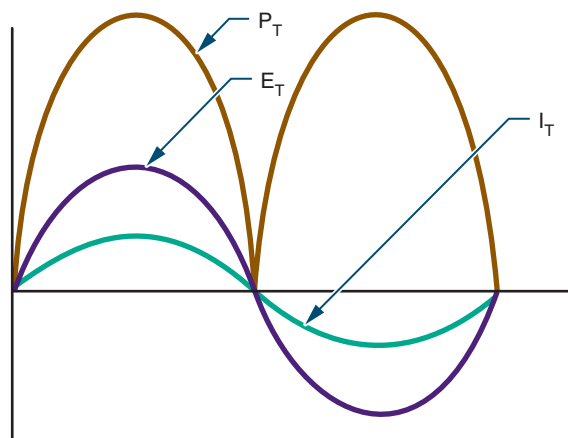
The power consumed by the resistor in an AC circuit varies with the amount of current flowing through it and the voltage applied across it. Figure 14-7 shows the relationship of power, current, and voltage. The power curve does not fall below the reference line because the power is dissipated in the form of heat. It does not matter in which direction the current is flowing, as power is assumed to have a positive value.

Power varies between the peak value and zero. Midway between peak value and zero is the average power consumed by the circuit. In an AC circuit, the average power is the power consumed. This can be determined by multiplying the effective voltage value by the effective current value. This is expressed as:

$$P = IE$$

FIGURE 14-7

The relationship of power, current, and voltage in a resistive AC circuit.



EXAMPLE: What is the power consumption in an AC circuit with 120 volts applied across 150 ohms of resistance? (Remember, when the voltage value is not specified for an AC source, it is assumed to be the effective value.)

Given:

$$I_T = ?$$

$$E_T = 120 \text{ V}$$

$$R_T = 150 \ \Omega$$

$$P_T = ?$$

Solution:

First, find the total current (I_T).

$$I_T = \frac{E_T}{R_T}$$

$$I_T = \frac{120}{150}$$

$$I_T = 0.80 \text{ A}$$

Now, find the total power (P_T).

$$P_T = I_T E_T$$

$$P_T = (0.80)(120)$$

$$P_T = 96 \text{ W}$$

When the current is not given, the current must be determined prior to using the power for-

mula. The resistance in this circuit consumes 96 watts of power.

14-4 QUESTIONS

1. What is the total power consumption of the following circuits:

Series:

a. $E_T = 100 \text{ V}$, $R_1 = 680 \ \Omega$, $R_2 = 1200 \ \Omega$

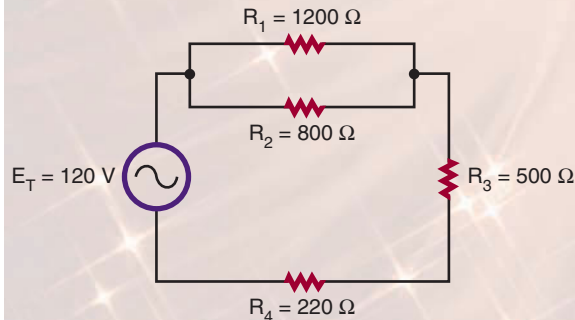
b. $I_T = 250 \text{ mA}$, $R_1 = 100 \ \Omega$, $R_2 = 500 \ \Omega$

Parallel:

c. $E_T = 100 \text{ V}$, $R_1 = 470 \ \Omega$, $R_2 = 1000 \ \Omega$

d. $I_T = 7.5 \text{ mA}$, $E_{R_1} = 10 \text{ V}$, $R_2 = 4.7 \text{ k}\Omega$

2. Find the power consumption of each individual component in the following circuit.



SUMMARY

- A basic AC resistive circuit consists of a voltage source, conductors, and a resistive load.
- The current is in phase with the applied voltage in a resistive circuit.
- The effective value of AC current or voltage produces the same results as the equivalent DC voltage or current.
- The effective values are the most widely used measurement values.
- Ohm's law can be used with all effective values.
- AC voltage or current values are assumed to be the effective values if not otherwise specified.

CHAPTER 14 SELF-TEST

1. Explain the phase relationship between current and voltage in a pure resistive circuit.
2. What is the effective voltage of an AC circuit with 25 mA flowing through 4.7 k Ω ?
3. What is the voltage drop across two resistors of 4.7 k Ω and 3.9 k Ω in series with an AC voltage of 12 V applied?
4. If two parallel resistors of 2.2 k Ω and 5.6 k Ω have an AC effective voltage of 120 V applied across their input, what is the current developed through each of the resistors?
5. What determines the power consumption in an AC circuit?
6. What is the power consumption in an AC circuit with 120 V applied across a load of 1200 Ω ?

Capacitive AC Circuits

OBJECTIVES

After completing this chapter, the student should be able to:

- Describe the phase relationship between current and voltage in a capacitive AC circuit.
- Determine the capacitive reactance in an AC capacitive circuit.
- Describe how resistor-capacitor networks can be used for filtering, coupling, and phase shifting.
- Explain how low-pass and high-pass RC filters operate.



See accompanying CD for Capacitive AC Circuit examples in MultiSim, Chapter 15.

Capacitors are key components of AC circuits. Capacitors combined with resistors and inductors form useful electronic networks.

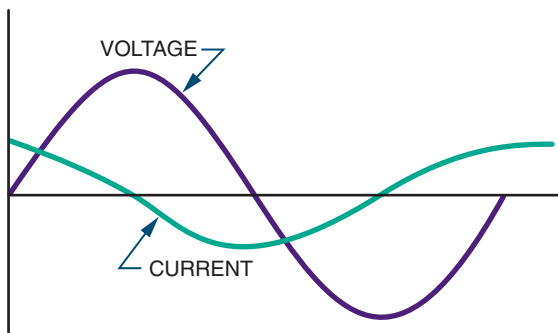
15-1 CAPACITORS IN AC CIRCUITS

When an AC voltage is applied to a capacitor, it gives the appearance that electrons are flowing in the circuit. However, electrons do not pass through the dielectric of the capacitor. As the applied AC voltage increases and decreases in amplitude, the capacitor charges and discharges. The resulting movement of electrons from one plate of the capacitor to the other represents current flow.

The current and applied voltage in a capacitive AC circuit differ from those in a pure resistive circuit. In a pure resistive circuit the current flows in phase with the applied voltage. Current and voltage in a capacitive AC circuit do not flow in phase with each other (Figure 15-1). When the voltage starts to increase, current is at maximum because the capacitor is discharged. As soon as the capacitor charges to the peak AC voltage the charging current drops to zero. As the voltage begins to drop, the capacitor begins discharging. The current begins to increase in a negative direction. When the current is at maximum, the voltage is at zero. This relationship is described as 90 degrees out of phase. The current leads the applied voltage in a capacitive circuit. The negative voltage peaks when the voltage

FIGURE 15-1

Note the out-of-phase relationship between the current and the voltage in a capacitive AC circuit. The current leads the applied voltage.



equals zero volts. The phase difference continues through each cycle. In a purely capacitive circuit, the current leads the voltage by an angle of 90 degrees. This can be represented by the acronym **ICE**. Current (I) leads the voltage (E) in a capacitive (C) circuit.

In a capacitive AC circuit, the applied voltage is constantly changing, causing the capacitor to charge and discharge. After the capacitor is initially charged, the voltage stored on its plates opposes any change in the applied voltage. The opposition that the capacitor offers to the applied AC voltage is called **capacitive reactance**. Capacitive reactance is represented by X_C and is measured in ohms.

Capacitive reactance can be calculated by using the formula:

$$X_C = \frac{1}{2\pi fC}$$

where: π = pi, the constant 3.14

f = frequency in hertz

C = capacitance in farads

Capacitive reactance is a function of the frequency of the applied AC voltage and the capacitance. Increasing the frequency decreases the reactance, resulting in greater current flow. De-

creasing the frequency increases the opposition and decreases current flow.

EXAMPLE: What is the capacitive reactance of a 1-microfarad capacitor at 60 hertz?

Given:

$$X_C = ?$$

$$\pi = 3.14$$

$$f = 60 \text{ Hz}$$

$$C = 1 \mu\text{F} = 0.000001 \text{ F}$$

Solution:

$$X_C = \frac{1}{2\pi fC}$$

$$X_C = \frac{1}{(2)(3.14)(60)(0.000001)}$$

$$X_C = 2653.93 \Omega$$

EXAMPLE: What is the capacitive reactance of a 1-microfarad capacitor at 400 hertz?

Given:

$$X_C = ?$$

$$\pi = 3.14$$

$$f = 400 \text{ Hz}$$

$$C = 1 \mu\text{F} = 0.000001 \text{ F}$$

Solution:

$$X_C = \frac{1}{2\pi fC}$$

$$X_C = \frac{1}{(2)(3.14)(400)(0.000001)}$$

$$X_C = 398.09 \Omega$$

EXAMPLE: What is the capacitive reactance of a 0.1-microfarad capacitor at 60 hertz?

Given:

$$X_C = ?$$

$$\pi = 3.14$$

$$f = 60 \text{ Hz}$$

$$C = 0.0000001 \text{ F} = 0.1 \mu\text{F}$$

Solution:

$$X_C = \frac{1}{2\pi fC}$$

$$X_C = \frac{1}{(2)(3.14)(60)(0.0000001)}$$

$$X_C = 26,539.28 \Omega$$

EXAMPLE: What is the capacitive reactance of a 10-microfarad capacitor at 60 hertz?

Given:

$$X_C = ?$$

$$\pi = 3.14$$

$$f = 60 \text{ Hz}$$

$$C = 10 \mu\text{F} = 0.00001 \text{ F}$$

Solution:

$$X_C = \frac{1}{2\pi fC}$$

$$X_C = \frac{1}{(2)(3.14)(60)(0.00001)}$$

$$X_C = 265.39 \Omega$$

Capacitive reactance is the opposition to changes in the applied AC voltage by a capacitor. In an AC circuit, a capacitor is thus an effective way of controlling current. Using Ohm's law, the current is directly proportional to the applied voltage and inversely proportional to the capacitive reactance. This is expressed as:

$$I = \frac{E}{X_C}$$

Note: X_C (capacitive reactance) has been substituted for R (resistance) in Ohm's law.

It is important to keep in mind that capacitive reactance depends on the frequency of the applied voltage and the capacitance in the circuit.

EXAMPLE: A 100-microfarad capacitor has 12 volts applied across it at 60 hertz. How much current is flowing through it?

Given:

$$I = ?$$

$$E = 12 \text{ VAC}$$

$$\pi = 3.14$$

$$f = 60 \text{ Hz}$$

$$C = 100 \mu\text{F} = 0.0001 \text{ F}$$

Solution:

First, find the capacitive reactance (X_C).

$$X_C = \frac{1}{2\pi fC}$$

$$X_C = \frac{1}{(2)(3.14)(60)(0.0001)}$$

$$X_C = 26.54 \Omega$$

Using X_C , now find the current flow:

$$I = \frac{E}{X_C}$$

$$I = \frac{12}{26.54}$$

$$I = 0.452 \text{ A or } 452 \text{ mA}$$

EXAMPLE: A 10-microfarad capacitor has 250 milliamperes of current flowing through it. How much voltage at 60 hertz is applied across the capacitor?

Given:

$$X_C = ?$$

$$\pi = 3.14$$

$$f = 60 \text{ Hz}$$

$$C = 10 \mu\text{F} = 0.00001 \text{ F}$$

$$I = 250 \text{ mA or } 0.25 \text{ A}$$

$$E = ?$$

Solution:

First, find the capacitive reactance (X_C).

$$X_C = \frac{1}{2\pi fC}$$

$$X_C = \frac{1}{(2)(3.14)(60)(0.00001)}$$

$$X_C = 265.39 \Omega$$

Now, find the voltage drop (E).

$$I = \frac{E}{X_C}$$

$$0.25 = \frac{E}{265.39}$$

$$E = 66.35 \text{ V}$$

When capacitors are connected in series, the capacitive reactance is equal to the sum of the individual capacitive reactance values.

$$X_{C_T} = X_{C_1} + X_{C_2} + X_{C_3} \dots + X_{C_n}$$

When capacitors are connected in parallel, the reciprocal of the capacitive reactance is equal to the sum of the reciprocals of the individual capacitive reactance values.

$$\frac{1}{X_{C_T}} = \frac{1}{X_{C_1}} + \frac{1}{X_{C_2}} + \frac{1}{X_{C_3}} \dots + \frac{1}{X_{C_n}}$$

15-1 QUESTIONS

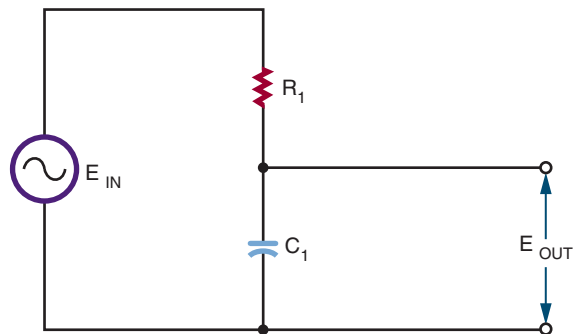
1. Describe how an AC voltage appears to make current move through a capacitor.
2. What is the relationship between current and voltage in a capacitive circuit?
3. What is capacitive reactance?
4. What is the capacitive reactance of a 10-microfarad capacitor at 400 hertz?

15-2 APPLICATIONS OF CAPACITIVE CIRCUITS

Capacitors can be used alone or combined with resistors to form *RC (resistor-capacitor) networks*. RC networks are used for filtering, decoupling, DC blocking, or coupling phase-shift circuits.

A filter is a circuit that discriminates among frequencies, attenuating (weakening) some while allowing others to pass. It works by establishing a

FIGURE 15-2
RC low-pass filter.



cut-off point between frequencies that are passed and frequencies that are attenuated. The two most common types of filters are low-pass filters and high-pass filters. A **low-pass filter** allows low frequencies to pass with little opposition while attenuating the high frequencies. A **high-pass filter** permits frequencies above the cut-off point to pass while attenuating frequencies below the cut-off point.

A low-pass filter (Figure 15-2) consists of a capacitor and a resistor in series. The input voltage is applied across both capacitor and resistor. The output is taken from across the capacitor. At low frequencies, the capacitive reactance is higher than the resistance, so most of the voltage is dropped across the capacitor. Therefore, most of the voltage appears across the output. As the input frequency increases, the capacitive reactance decreases, and less voltage is dropped across the capacitor. Therefore, more voltage is dropped across the resistor, with a decrease in the output voltage. The cut-off is gradual. Frequencies above the cut-off point pass with a gradual attenuation in the output voltage. Figure 15-3 shows a frequency response curve for an RC low-pass filter.

A high-pass filter also consists of a resistor and capacitor in series (Figure 15-4). However, the output is taken across the resistor. At high frequencies,

FIGURE 15-3

Frequency response of an RC low-pass filter.

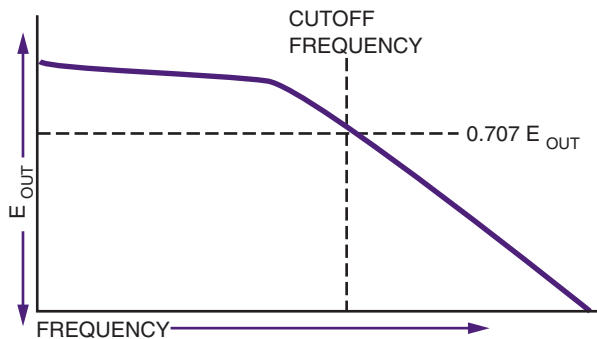


FIGURE 15-5

Frequency response of an RC high-pass filter.

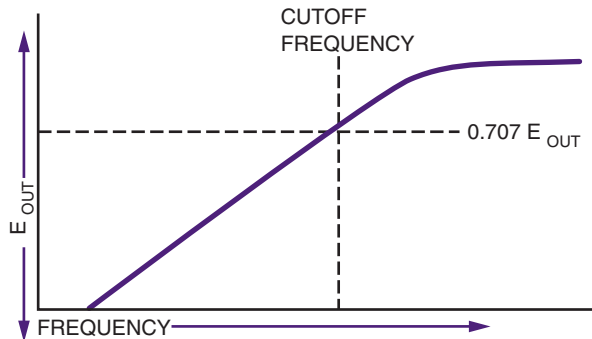
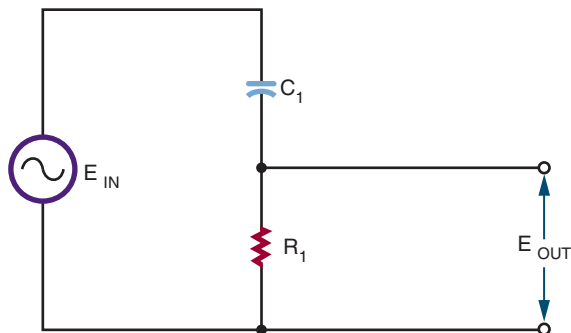


FIGURE 15-4

RC high-pass filter.

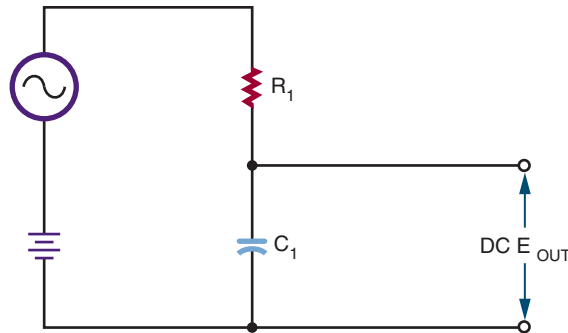


the capacitive reactance is low, and most of the voltage is dropped across the resistor. As the frequency decreases, the capacitive reactance increases, and more voltage is dropped across the capacitor. This results in a decrease in the output voltage across the resistor. Again, the drop in output voltage is gradual. Figure 15-5 shows a frequency response curve for an RC high-pass filter.

Most electronic circuits include both AC and DC voltages. This results in an AC signal superimposed on a DC signal. If the DC signal is used to operate equipment, it is advantageous to remove the AC signals. An RC low-pass filter can be used for this purpose. A *decoupling network* (Figure 15-6) al-

FIGURE 15-6

RC decoupling network.



lows the DC signal to pass while attenuating or eliminating the AC signal. The AC signal may be in the form of oscillations, noises, or transient spikes. By adjusting the cut-off frequency, most of the AC signal can be filtered out, leaving only the DC voltage across the capacitor.

In another application, it may be desirable to pass the AC signal while blocking the DC voltage. This type of circuit is called a *coupling network* (Figure 15-7). An RC high-pass filter can be used. Initially the capacitor charges to the DC voltage level. Once the capacitor is charged, no more DC current can flow in the circuit. The AC source causes the capacitor to charge and dis-

FIGURE 15-7
RC coupling network.

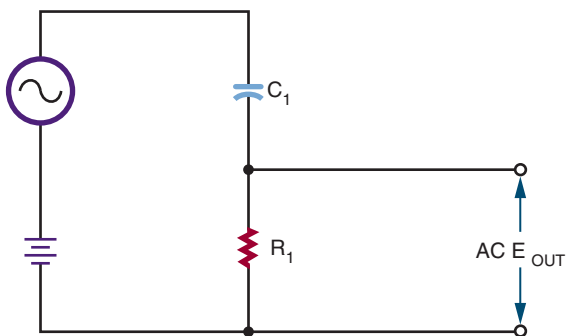
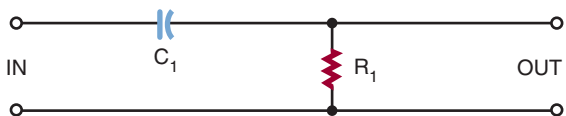


FIGURE 15-8
Leading output phase-shift network. The output voltage leads the input voltage.



charge at the AC rate, creating current flow through the resistor. The component values are chosen so that the AC signal is passed with a minimum of attenuation.

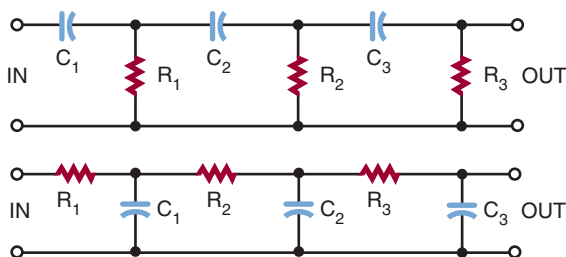
At times it is necessary to shift the phase of the AC output signal with respect to the input signal. RC networks can be used for phase-shifting applications. The RC **phase-shift networks** are used only where small amounts of phase shift, less than 60 degrees, are desired.

Figure 15-8 shows a phase-shift network with the input applied across the resistor-capacitor combination and the output taken across the resistor. In the circuit, the current leads the voltage because of the capacitor. The voltage across the resistor is in phase with the resistor. This results in the output voltage leading the input voltage.

FIGURE 15-9
Lagging output phase-shift network. The voltage across the capacitor lags the applied voltage.



FIGURE 15-10
Cascaded RC phase-shift networks.



In Figure 15-9, the output is taken across the capacitor. The current in the circuit leads the applied voltage. However, the voltage across the capacitor lags the applied voltage.

To achieve greater phase shifts, several RC networks may be cascaded (connected) together (Figure 15-10). Cascaded networks reduce the output voltage, however. An amplifier is needed to raise the output voltage to the proper operating level.

Phase-shift networks are valid for only one frequency, because the capacitive reactance varies with changes in frequency. Changing the reactance results in a different phase shift.

15-2 QUESTIONS

1. What are three uses of resistor-capacitor networks in electronic circuits?
2. Draw a diagram of a low-pass filter and describe how it works.
3. Draw a diagram of a high-pass filter and describe how it works.

4. What is the purpose of a decoupling network?
5. What do RC phase shift networks do?

SUMMARY

- When an AC voltage is applied to a capacitor, it gives the appearance of current flow.
 - The capacitor charging and discharging represents current flow.
 - The current leads the applied voltage by 90 degrees in a capacitive circuit.
 - Capacitive reactance is the opposition a capacitor offers to the applied voltage.
- Capacitive reactance is represented by X_C .
 - Capacitive reactance is measured in ohms.
 - Capacitive reactance can be calculated by the formula:

$$X_C = \frac{1}{2\pi fC}$$

- RC networks are used for filtering, coupling, and phase shifting.
- A filter is a circuit that discriminates against certain frequencies.
- A low-pass filter passes frequencies below a cut-off frequency. It consists of a resistor and capacitor in series.
- A high-pass filter passes frequencies above a cut-off frequency. It consists of a capacitor and resistor in series.
- Coupling networks pass AC signals but block DC signals.

CHAPTER 15 SELF-TEST

1. What is the relationship between current and the applied voltage in a capacitive circuit?
2. What is the capacitive reactance of a 1000- μ F capacitor at 60 Hz?
3. In question 2, what is the current flow through the capacitor with 12 V applied?
4. List three applications for capacitive circuits.
5. Why are capacitive coupling circuits important?

Inductive AC Circuits

OBJECTIVES

After completing this chapter, the student should be able to:

- Describe the phase relationship between current and voltage in an inductive AC circuit.
- Determine the inductive reactance in an AC circuit.
- Explain impedance and its effect on inductive circuits.
- Describe how an inductor-resistor network can be used for filtering and phase shifting.
- Explain how low-pass and high-pass inductive circuits operate.



See accompanying CD for Inductive AC Circuit examples in MultiSim, Chapter 16.

Inductors, like capacitors, oppose current flow in AC circuits. They may also introduce a phase shift between the voltage and the current in AC circuits. A large number of electronic circuits are composed of inductors and resistors.

16-1 INDUCTANCE IN AC CIRCUITS

Inductors in AC circuits offer opposition to current flow. When an AC voltage is placed across an inductor, it creates a magnetic field. As the AC voltage changes polarity, it causes the magnetic field to expand and collapse. It also induces a voltage in the inductor coil. This induced voltage

is called a counter electromotive force (cemf), the greater the inductance, the greater the cemf. The cemf is out of phase with the applied voltage by 180 degrees (Figure 16-1) and opposes the applied voltage. This opposition is as effective in reducing current flow as a resistor.

The amount of voltage induced in the inductor depends on the rate of change of the magnetic field. The faster the magnetic field expands and collapses, the greater the induced voltage. The total effective voltage across the inductor is the difference between the applied voltage and the induced voltage. The induced voltage is always less than the applied voltage.

Figure 16-2 shows the relationship of the current to the applied voltage. In a purely inductive

FIGURE 16-1

The applied voltage and the induced voltage are 180 degrees out of phase with each other in an inductive circuit.

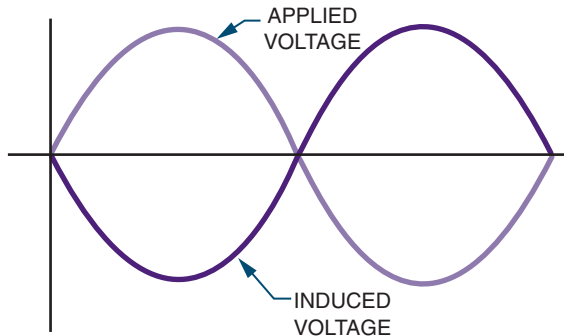
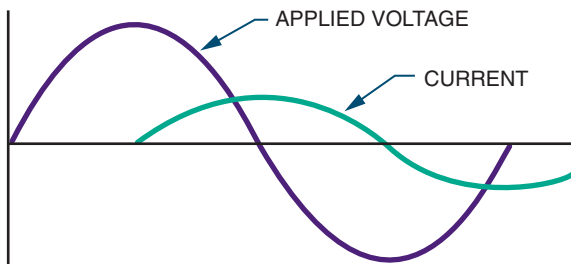


FIGURE 16-2

The current lags the applied voltage in an AC inductive circuit.



circuit, the current lags behind the applied voltage by 90 degrees. Another way of stating this is that the applied voltage leads the current by 90 degrees in a pure inductive circuit. This can be represented by the acronym **ELI**. Voltage (E) leads current (I) in an inductive (L) circuit.

The opposition offered to current flow by an inductor in an AC circuit is called **inductive reactance**. Inductive reactance is measured in ohms. The amount of inductive reactance offered by an inductor depends on its inductance and the frequency of the applied voltage. The larger the inductance, the larger the magnetic field generated

and the greater the opposition to current flow. Also, the higher the frequency, the greater the opposition to current flow.

Inductive reactance is expressed by the symbol X_L . Inductive reactance is determined by the formula:

$$X_L = 2\pi fL$$

where: $\pi = \text{pi or } 3.14$

$f = \text{frequency in hertz}$

$L = \text{inductance in henries}$

EXAMPLE: What is the inductive reactance of a 0.15-henry coil at 60 hertz?

Given:

$X_L = ?$

$\pi = 3.14$

$f = 60 \text{ Hz}$

$L = 0.15 \text{ H}$

Solution:

$X_L = 2\pi fL$

$X_L = (2)(3.14)(60)(0.15)$

$X_L = 56.52 \Omega$

EXAMPLE: What is the inductive reactance of a 0.15-henry coil at 400 hertz?

Given:

$X_L = ?$

$\pi = 3.14$

$f = 400 \text{ Hz}$

$L = 0.15 \text{ H}$

Solution:

$X_L = 2\pi fL$

$X_L = (2)(3.14)(400)(0.15)$

$X_L = 376.80 \Omega$

Notice that the inductive reactance increases with the increase in frequency.

Ohm's law applies to inductive reactance in AC circuits in the same manner that it applies to resistance. The inductive reactance in an AC circuit is directly proportional to the applied voltage and inversely proportional to the current. This relationship is expressed as:

$$I = \frac{E}{X_L}$$

The inductance increases with an increase in voltage or a decrease in current. Likewise, a decrease in inductive reactance results from a decrease in voltage or an increase in current.

EXAMPLE: How much current flows through a 250-millihenry inductor when a signal of 12 volts and 60 hertz is applied across it?

Given:

$$\begin{aligned}X_L &= ? \\ \pi &= 3.14 \\ f &= 60 \text{ Hz} \\ L &= 0.25 \text{ H} \\ I &= ? \\ E &= 12 \text{ V}\end{aligned}$$

Solution:

First, find the inductive reactance (X_L).

$$\begin{aligned}X_L &= 2\pi fL \\ X_L &= (2)(3.14)(60)(0.25) \\ X_L &= 94.20 \Omega\end{aligned}$$

Using X_L , now find the current flow (I).

$$\begin{aligned}I &= \frac{E}{X_L} \\ I &= \frac{12}{94.20} \\ I &= 0.127 \text{ amp or } 127 \text{ mA}\end{aligned}$$

EXAMPLE: How much voltage is necessary to cause 10 milliamperes to flow through a 15-millihenry choke at 400 Hz?

Given:

$$\begin{aligned}X_L &= ? \\ \pi &= 3.14 \\ f &= 400 \text{ Hz} \\ L &= 0.015 \text{ H} \\ I &= 0.01 \text{ A} \\ E &= ?\end{aligned}$$

Solution:

First, find the inductive reactance (X_L).

$$\begin{aligned}X_L &= 2\pi fL \\ X_L &= (2)(3.14)(400)(0.015) \\ X_L &= 37.68 \Omega\end{aligned}$$

Using X_L , now find the voltage (E).

$$\begin{aligned}I &= \frac{E}{X_L} \\ 0.01 &= \frac{E}{37.68} \\ E &= 0.38 \text{ V}\end{aligned}$$

EXAMPLE: What is the inductive reactance of a coil that has 120 volts applied across it with 120 milliamperes of current flow?

Given:

$$I = 0.12 \text{ A}$$

$$E = 120 \text{ V}$$

$X_L = ?$

Solution:

$$I = \frac{E}{X_L}$$

$$0.12 = \frac{120}{X_L}$$

$$X_L = 1000 \Omega$$

The impedance of a circuit containing both inductance and resistance is the total opposition to current flow by both the inductor and the resistor. Because of the phase shift caused by the inductor, the inductive reactance and the resistance cannot be added directly. The impedance is the vector sum of the inductive reactance and the resistance in the circuit. The impedance is expressed in ohms and is designated by the letter Z . Impedance can be defined in terms of Ohm's law as:

$$I = \frac{E}{Z}$$

The most common inductive circuit consists of a resistor and an inductor connected in series. This is referred to as an *RL circuit*. The impedance of a series RL circuit is the square root of the sum of the squares of the inductive reactance and the resistance. This can be expressed as:

$$Z = \sqrt{R^2 + X_L^2}$$

EXAMPLE: What is the impedance of a 100-millihenry choke in series with a 470-ohm resistor with 12 volts, 60 hertz applied across them?

Given:

$$X_L = ?$$

$$\pi = 3.14$$

$$f = 60 \text{ Hz}$$

$$100 \text{ mH} = 0.1 \text{ H}$$

$$Z = ?$$

$$R = 470 \Omega$$

Solution:

First, find the inductive reactance (X_L).

$$X_L = 2\pi fL$$

$$X_L = (2)(3.14)(60)(0.1)$$

$$X_L = 37.68 \Omega$$

Using X_L , now find the impedance (Z).

$$Z = \sqrt{R^2 + X_L^2}$$

$$Z = \sqrt{(470)^2 + (37.68)^2}$$

$$Z = 471.51 \Omega$$

When inductors are connected in series, the inductive reactance is equal to the sum of the individual inductive reactance values.

$$X_{L_T} = X_{L_1} + X_{L_2} + X_{L_3} \dots + X_{L_n}$$

When inductors are connected in parallel, the reciprocal of the inductive reactance is equal to the sum of the reciprocals of the individual inductive reactance values.

$$\frac{1}{X_{L_T}} = \frac{1}{X_{L_1}} + \frac{1}{X_{L_2}} + \frac{1}{X_{L_3}} \dots + \frac{1}{X_{L_n}}$$

16-1 QUESTIONS

1. What does an AC voltage do when applied across an inductor?
2. What is the relationship between current and voltage in an inductive circuit?
3. What is inductive reactance?
4. What is the inductive reactance of a 200-millihenry inductor at 10,000 hertz?

5. How is the impedance determined for an inductor-resistor network?

16-2 APPLICATIONS OF INDUCTIVE CIRCUITS

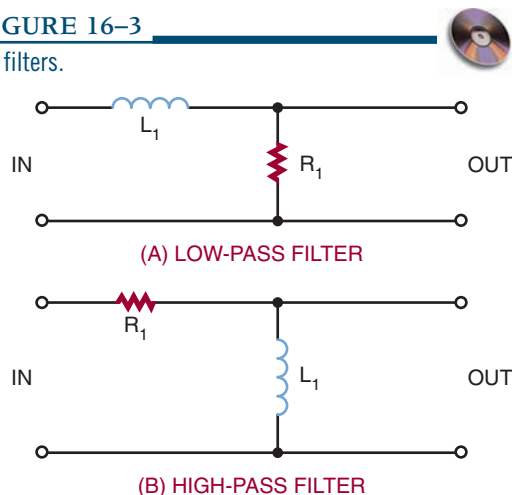
Inductive circuits are widely used in electronics. Inductors compete with capacitors for filtering and phase-shift applications. Because inductors are larger, heavier, and more expensive than capacitors, they have fewer applications than capacitors. However, inductors have the advantage of providing a reactive effect while still completing a DC circuit path. Capacitors can provide a reactive effect, but block the DC elements.

Inductors are sometimes combined with capacitors to improve the performance of a circuit. The reactive effect of the capacitor then opposes the reactive effect of the inductor. The end result is that they complement each other in a circuit.

Series RL networks are used as low- and high-pass filters. Figure 16-3 shows the two basic types of filters. The circuits are essentially resistor-inductor voltage dividers. Figure 16-3A is a low-

FIGURE 16-3

RL filters.



pass filter. The input is applied across the inductor and resistor. The output is taken from across the resistor. At low frequencies, the reactance of the coil is low. Therefore it opposes little current and most of the voltage is dropped across the resistor. As the input frequency increases, the inductive reactance increases and offers more opposition to current flow, so that more voltage drops across the inductor. With more voltage dropped across the inductor, less voltage is dropped across the resistor. Increasing the input frequency decreases the output voltage. Low frequencies are passed with little reduction in amplitude while high frequencies are greatly reduced in amplitude.

Figure 16–3B is a high-pass filter. The input is applied across the inductor and resistor and the output is taken across the inductor. At high frequencies, the inductive reactance of the coil is high, causing most of the voltage to be dropped across the coil. As the frequency decreases, the inductive reactance decreases, offering less opposition to the current flow. This causes less voltage to be dropped across the coil and more voltage to be dropped across the resistor.

The frequency above or below the frequencies passed or attenuated is called the *cut-off frequency*. The symbol for the cut-off frequency is f_{CO} . The cut-off frequency can be determined by the formula:

$$f_{CO} = \frac{R}{2\pi fL}$$

where: f_{CO} = cut-off frequency in hertz
 R = resistance in ohms
 π = 3.14
 f = frequency in hertz
 L = inductance in henries

16–2 QUESTIONS

1. What are the disadvantages of using inductors in circuits?
2. What are the advantages of using inductors in circuits?
3. Draw a diagram of an RL low-pass filter and explain how it operates.
4. Draw a diagram of an RL high-pass filter and explain how it operates.
5. How can the cut-off frequency of an RL circuit be determined?

SUMMARY

- In a pure inductive circuit, the current lags the applied voltage by 90 degrees.
- Inductive reactance is the opposition to current flow offered by an inductor in an AC circuit.
- Inductive reactance is represented by X_L .
- Inductive reactance is measured in ohms.
- Inductive reactance can be calculated by the formula:

$$X_L = 2\pi fL$$
- Impedance is the vector sum of the inductive reactance and the resistance in the circuit.
- Series RL circuits are used for low- and high-pass filters.

CHAPTER 16 SELF-TEST

1. What is the relationship between current and the applied voltage in an inductive circuit?
2. What factor affects the inductive reactance of an inductive circuit?

3. What is the inductive reactance of a 100-mH coil at 60 Hz?
4. How much current would flow through the inductor in question 3 if 24 V were applied?
5. How are inductors used in circuits?
6. What is the cut-off frequency of an inductive circuit?

Resonance Circuits

OBJECTIVES

After completing this chapter, the student should be able to:

- Identify the formulas for determining capacitive and inductive reactance.
- Identify how AC current and voltage react in capacitors and inductors.
- Determine the reactance of a series circuit, and identify whether it is capacitive or inductive.
- Define the term *impedance*.
- Solve problems for impedance that contain both resistance and capacitance or inductance.
- Discuss how Ohm's law must be modified prior to using it for AC circuits.
- Solve for X_C , X_L , X , Z , and I_T in RLC series circuits.
- Solve for I_C , I_L , I_X , I_R , and I_Z in RLC parallel circuits.



See accompanying CD for interactive presentations, tutorials, and DC Circuit examples in MultiSim, Chapter 17.

In previous chapters, resistance, capacitance, and inductance in AC circuits were looked at individually in a circuit. In this chapter, resistance, capacitance, and inductance will be observed as connected together in an AC circuit. The concepts covered in this chapter will not present any new material, but will apply all of the principles presented so far.

When the reactance of the inductor equals the reactance of the capacitor, it forms a resonant circuit. Resonant circuits are used in a variety of circuits in electronics.

17-1 REACTANCE IN SERIES CIRCUITS

A series circuit (Figure 17-1) DC voltage is generally supplied by a battery. The value of the amount of current flowing in a circuit may be determined by Ohm's law, which uses the battery voltage and resistance of the circuit.

When an AC voltage source is applied to a circuit (Figure 17-2), the instantaneous value of

FIGURE 17-1

DC resistive circuit.

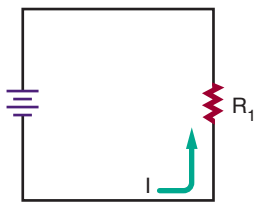
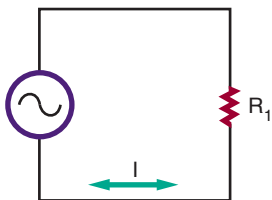


FIGURE 17-2

AC resistive circuit.



current flowing through the resistor varies with the alternating output voltage applied. Ohm's law applies to the AC circuit just as it does with the DC circuit. Peak current may be calculated from the source's peak voltage, and rms current from the rms voltage.

Figure 17-3 shows a graph of one cycle of AC. It shows that when the voltage reaches a peak, the current also reaches a peak. Both the voltage and the current cross the zero line together. The two waveforms are said to be *in phase*. This is the condition that occurs when a circuit contains pure resistance and no reactive components.

The effects of pure inductance or capacitance cause the voltage or current of a circuit to be 90 degrees *out of phase*. This situation becomes more complex when both reactive and resistance components are combined—a condition that is typical of an AC circuit.

In Figure 17-4, the components are shown connected in a series circuit, and the current flows equally through both components. Resistor R_1

FIGURE 17-3

In a resistive AC circuit, current and voltage are in phase.

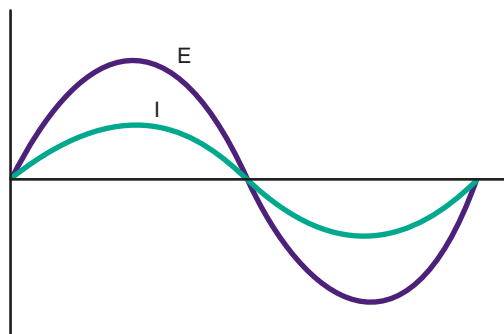
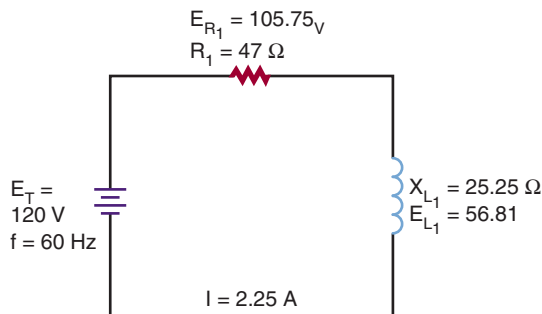


FIGURE 17-4

Voltage in either RL circuits such as this one or in RC circuits are not in phase and cannot be added directly.

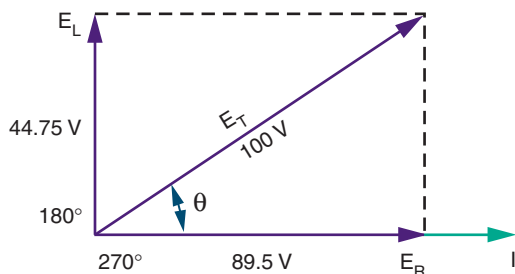


has a value of 47 ohms, and the calculated value of inductive reactance for inductor L_1 is 25.25 ohms for the frequency of 60 hertz. The current flow in the circuit is 2.25 amperes, and the voltage drop across resistor R_1 is 105.75 volts and across inductor L_1 is 56.81 volts. These voltages appear to be incorrect because they total more than the supply voltage of 120 volts. This occurs because the voltage across the resistor is out of phase with the voltage across the inductor.

Voltage and current are in phase in the resistive portion of the circuit. In the inductive portion of the circuit, voltage leads the current

FIGURE 17-5

Vectors can be used to show the relationship between voltages in a reactive circuit.



by 90 degrees. Because the current at all points in a series circuit must be in phase, E_R and E_L are out of phase.

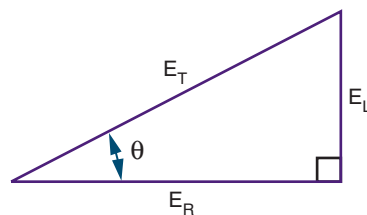
A way to represent voltage and current in circuits, such as the one in Figure 17-4, is to use vectors. *Vectors* are arrows that start at the origin of a coordinate system and point in a particular direction (Figure 17-5). The length of the arrow indicates the magnitude—the longer the arrow, the larger the value. The angle the arrow makes with the x-axis indicates its phase in degrees. The positive x-axis is zero degrees and the degrees increase as the arrow is moved in a counterclockwise direction.

In Figure 17-4, the current flows through both components with the same phase. The current vector is used as the zero degree reference and will lie on the x-axis. Voltage E_R is in phase with the current and its vector is also placed on the x-axis.

The voltage across the inductor, E_L , is 90 degrees ahead of the current. Therefore, its vector points straight up, or 90 degrees from the x-axis. Each vector is drawn to scale. The source voltage vector (E_T) is started at the origin and ends at the maximum values of E_R and E_L , as shown in Figure 17-5. The angle of the vector E_T (θ) is the phase between the source voltage and current, and its length indicates the voltage's magnitude.

FIGURE 17-6

Vectors can be rearranged to form a right triangle.



The base voltage diagram may be rearranged to form a right triangle, with the hypotenuse representing the longest vector (Figure 17-6). Scale drawings are not needed to determine magnitude because the Pythagorean Theorem states:

$$E_T = \sqrt{E_R^2 + E_L^2}$$

This formula may be used to calculate any vector when the other two legs are known.

Vector representation also allows the use of trigonometric functions to determine voltage when only one voltage and the phase angle is known. It also determines the phase angle when the two voltages are known. These relationships are:

$$\sin \theta = E_L/E_T$$

$$\cos \theta = E_R/E_T$$

$$\tan \theta = E_L/E_R$$

Using the example in Figure 17-4 and any of the relationships shown, the phase difference may be determined between the supply voltage and current as 28.26 degrees.

Experimenting with different values of E_L and E_R will reveal several useful tips to remember:

- When a circuit is purely resistive, the phase angle is zero because voltage and current are in phase.
- As the inductive reactance increases, the phase angle becomes greater until it reaches 45 degrees when the resistance and the reactance are equal in value. As the

inductive reactance increases further, the angle will approach 90 degrees.

- When a circuit contains pure reactance with no resistance the phase angle will increase to 90 degrees.

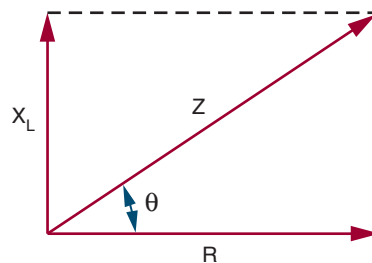
Current flow is the same through all components in a series circuit. The voltage drop across any component in the circuit is proportional to the resistance or reactance of that component. If vectors are drawn for the resistance and reactance of the circuit, they would be proportional to those drawn for the voltage (Figure 17-4). The resistance, R , would be drawn at 0 degrees and the inductive reactance, X_L , would be drawn at 90 degrees.

The combined effect of resistance and reactance is called *impedance* and is represented by the symbol Z . Impedance must be used to calculate the current in a reactive circuit when the supply voltage is known. Dividing the source voltage by the resistance added to the reactance will yield an incorrect answer because the voltages involved are not in phase with each other. Vectors may be used to describe the circuit impedance (Figure 17-7).

The series RC circuit in Figure 17-8A is described by the vector diagrams in Figure 17-8B and 17-8C. Again, the current is used as the zero-degree reference point, with E_R at 0 degrees since it is in

FIGURE 17-7

Vectors can also be used to describe impedance.



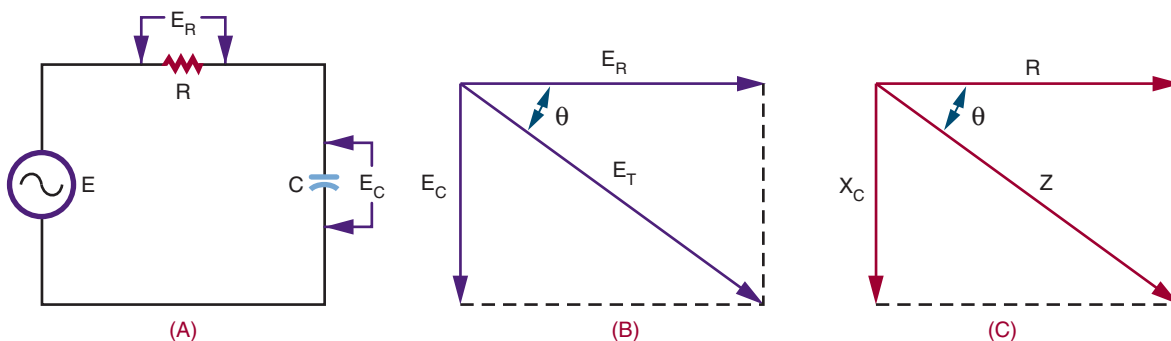
phase with the current. Remember, in a capacitive circuit, the voltage lags 90 degrees behind the current, so its voltage vector (E_C) is drawn downward. The phase angle of such a circuit is sometimes given a negative value, although it is just as acceptable to specify “leading” or “lagging” instead. All the same trigonometric equations and the Pythagorean Theorem may be applied to the vectors.

17-1 QUESTIONS

1. Draw a graph showing the relationship of current and voltage in a purely resistive series circuit.
2. Show the relationship between current and voltage for the circuit shown in Figure 17-9.

FIGURE 17-8

Vectors can be used to describe capacitive AC circuits, the same as inductive circuits.



3. For the circuit in Figure 17–9, draw a graph showing the vector relationship. Include all arrows and label each vector.
4. Using the Pythagorean Theorem, determine the impedance for the circuit shown in Figure 17–9.
5. Determine the phase angle for the circuit shown in Figure 17–9.
6. Verify the impedance for the circuit shown in Figure 17–9.
7. Verify the current flow for the circuit shown in Figure 17–9.

FIGURE 17–9

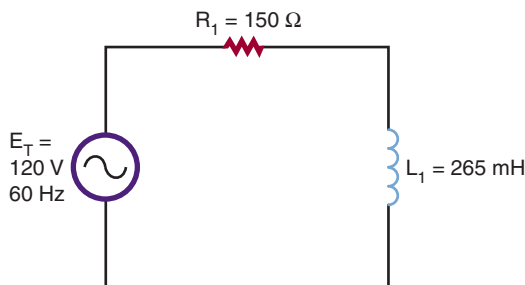
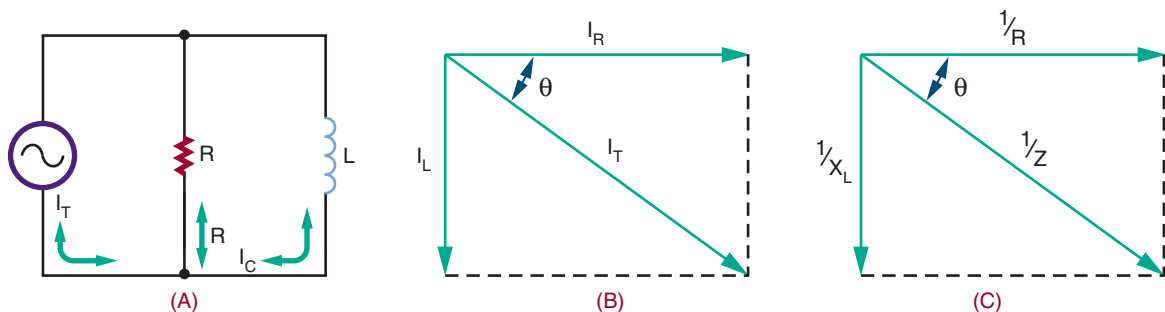


FIGURE 17–10

Vectors can be used to analyze parallel inductance circuits. Current flow, not voltage, is used because the voltage across each component is equal and in phase.



17–2 REACTANCE IN PARALLEL CIRCUITS

Parallel circuits containing inductors and capacitors may also be analyzed with vector diagrams. However, the vectors used are current vectors because the voltage across each component must be equal and in phase with each other.

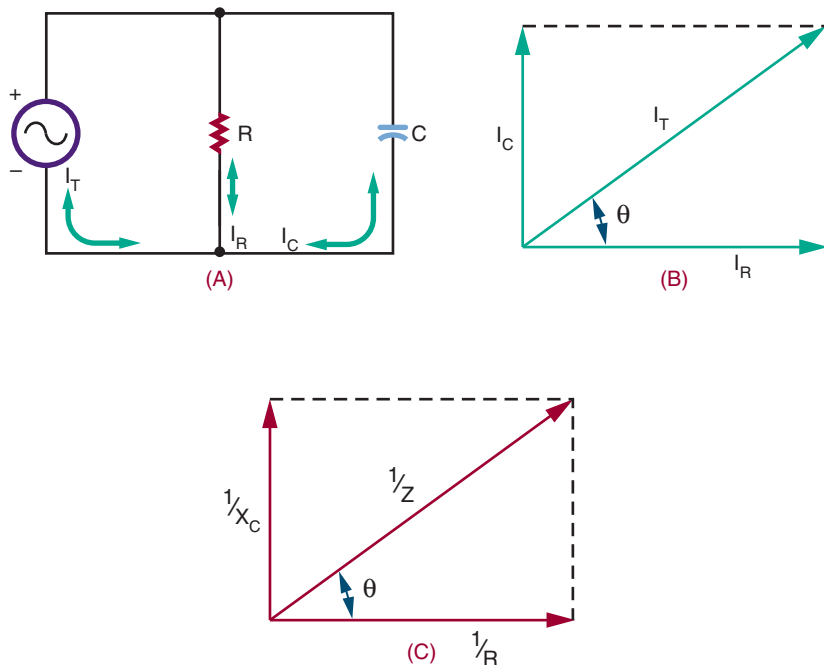
Figure 17–10 shows a parallel RL circuit and its resulting vector diagram. The vector for the resistor current is placed at 0 degrees. It is a simple matter to plot the vector for the inductor's current, I_L . The current through the inductor lags behind the voltage by 90 degrees, so the vector is drawn downward.

Figure 17–11 shows the vector diagram for a parallel RC circuit. Notice that the capacitive and inductive vectors (Figure 17–10) for parallel circuits are drawn in the opposite direction to those of a series circuit. Remember, in parallel circuits current is examined, not voltage.

Just as the resistance of a parallel circuit is always less than the value of the smallest resistor, the impedance of a parallel RL or RC circuit is smaller than both the individual resistance or reactance. Vectors may be used to determine parallel circuit impedance; however, the reciprocal values of R , X , and Z must be used. This

FIGURE 17-11

Vectors can be used to analyze parallel capacitance circuits.



makes impedance calculations a little more complex for parallel circuits. All the trigonometric functions mentioned previously are applicable to parallel circuits provided that the vectors are drawn correctly. Mathematically, for Figures 17-10 and 17-11:

Inductive circuits:

$$I = \sqrt{I_R^2 + I_L^2}$$

$$1/Z = 1/R + 1/X_L$$

Capacitive circuits:

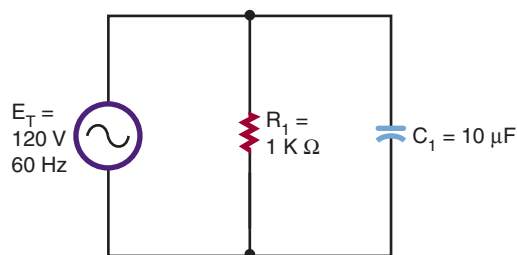
$$I = \sqrt{I_R^2 + I_C^2}$$

$$1/Z = 1/R + 1/X_C$$

17-2 QUESTIONS

1. Using the Pythagorean Theorem, calculate the resultant current flow for

FIGURE 17-12



the circuit shown in Figure 17-10. The total voltage is 120 V at 60 Hz, $R = 150 \Omega$ and $L = 265 \text{ mH}$.

2. Calculate the impedance of the circuit in Figure 17-12.

17-3 POWER

The power consumption of a purely resistive AC circuit is easy to determine. Calculate the product of the rms current and rms voltage to obtain the average power. Figure 17-13A shows a graphical method in which instantaneous power consumption may be calculated by plotting current and voltage on the same axes and then performing successive multiplications to plot the power curve.

The same principle may be applied to the reactive circuit (Figure 17-13B). Remember that a circuit containing just pure inductance shows current lagging voltage by 90 degrees. Plotting the power curve for this circuit yields an alternating waveform that is centered on 0. The net power consumption of an inductive circuit is low.

During the positive portion of the waveform, the inductor takes energy and stores it in the form of a magnetic field. During the negative portion of the waveform, the field collapses and the coil returns energy to the circuit. A similar situation occurs with pure capacitance, except the capacitor stores energy as an electrostatic field and the voltage-current phase relationship is reversed.

As resistance is introduced to a circuit, the phase angle becomes less than 90 degrees and the power curve will shift to a more positive value, showing that the circuit is taking more energy

than it is returning. However, the capacitive or inductive part of the circuit still stores and releases energy and consumes no power. The power loss is due entirely to the resistance. Remember, only the resistive part of the circuit consumes power.

Figure 17-14 shows a capacitive circuit. Using the Pythagorean Theorem, the resistance of 100 ohms and the capacitance reactance of 50 ohms gives a combined impedance (Z) of approximately 112 ohms, as follows:

$$Z = \sqrt{R_1^2 + X_{C_1}^2}$$

$$Z = \sqrt{100^2 + 50^2}$$

$$Z = 111.8 \Omega$$

Using Ohm's law, this would allow a current of approximately 1 amp to flow in the circuit. The voltage drop across the resistor would be 100 volts, so the true power dissipated by the resistor would be approximately 100 watts.

The capacitive part of the circuit consumes no power, yet multiplying the source voltage by circuit current yields an answer of 112 watts. The difference is accounted for by the difference in phases between the various voltages. As opposed to true power, the figure obtained by multiplying the source voltage and current is known as *apparent power*, and it is specified as 112 VA or 112 volt-amperes. The true power of the circuit can never be greater than the apparent power. The ratio of

FIGURE 17-13

Power dissipation in a resistive circuit has a non-zero value (A). In a reactive circuit, there is no average or net power loss (B).

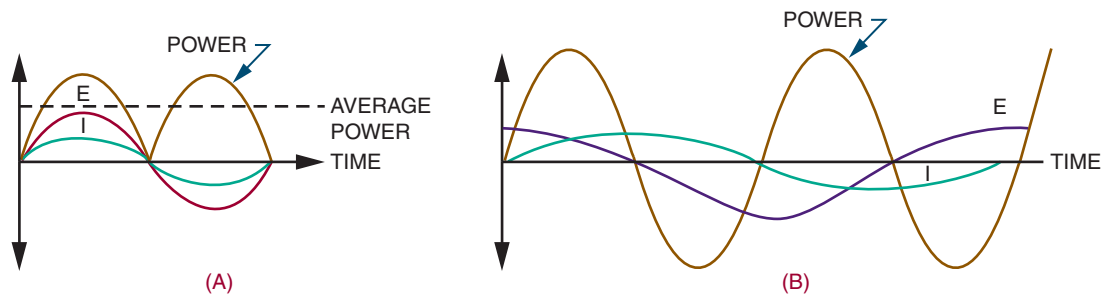
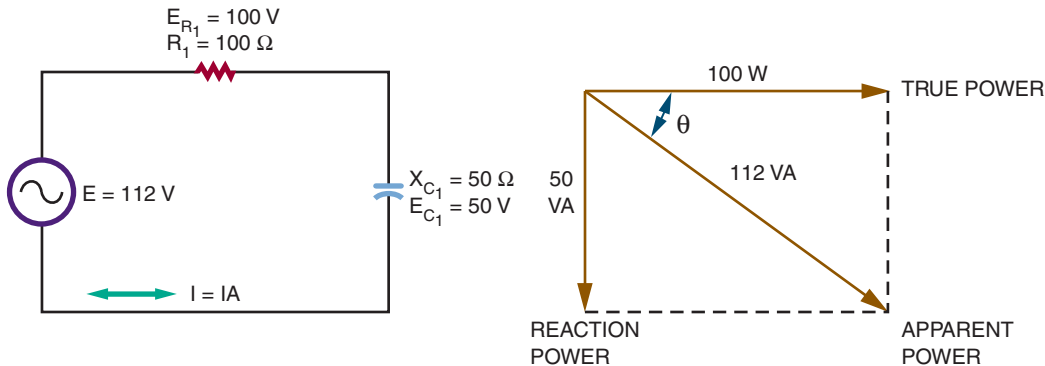


FIGURE 17-14

In a reactive circuit, the true power dissipated with resistance and the reactive power supplied to its reactance vectorly sum to produce an apparent power vector.



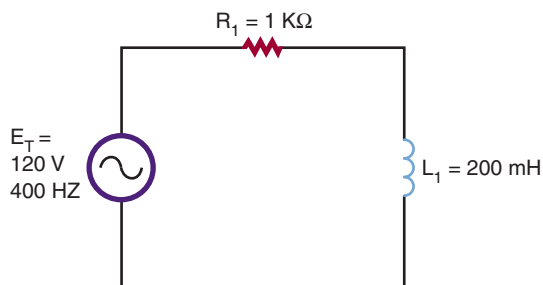
true power in watts to apparent power in volt-amps is called the *power factor*.

Vector diagrams may be used to analyze the power factor. If the phase angle of the circuit is known, the power factor may be calculated by taking the cosine of the angle. In the circuit shown in Figure 17-14, it is the same as the ratio of E_R to source voltage. Several methods are used to obtain the power factor based on the data available. In a pure resistive circuit, the true power is the same as the apparent power, so the power factor is 1. In a pure inductive or capacitive circuit the true power is 0—no matter what the apparent power is—so the power factor is 0. Power factor is an important consideration in heavy industrial power distribution where the cables must be capable of handling the apparent power load.

17-3 QUESTIONS

1. What is the net power consumption of an inductive circuit? Why?
2. Calculate the apparent power for the circuit shown in Figure 17-15.

FIGURE 17-15



3. Define *power factor*.
4. What is the relationship between true power and apparent power?

17-4 INTRODUCTION TO RESONANCE

Resonance is a phenomenon that occurs in many fields, including electronics. A resonance device produces a broadening and dampening

effect. In electronics, resonant circuits pass desired frequencies and reject all others. The ability of a series or parallel combination of X_L or X_C to produce resonance provides a number of unique applications. Resonant circuits make it possible for a radio or television receiver to tune in and receive a station at a particular frequency. The tuning circuit consists of a coil of wire in parallel with a capacitor. Parallel tuned circuits have maximum impedance at resonant frequencies. Tuned circuits are vital to a variety of types of communication equipment, from radios to radar.

Resonance occurs when a circuit's inductive and capacitive reactance are balanced. Previously, it was mentioned that inductive reactance increases with frequency, and capacitive reactance increases with frequency. If both inductive and capacitive components are in an AC circuit, at one particular frequency their reactances will be equal but opposite. This condition is referred to as *resonance*. A circuit that contains this characteristics is called a *resonant circuit*. Both inductance and capacitance must be present for this condition to occur.

In any resonant circuit, some resistance is usually present. Though the resistance does not have an effect on the resonant frequency, it does affect other resonant circuit parameters that will be explained later.

The value of inductance and capacitance determines the specific frequency of resonance of a circuit. Changing either or both will result in a different resonant frequency. Typically, the larger the value of inductance and capacitance, the lower the resonant frequency. Therefore, the smaller the value of inductance and capacitance, the higher the resonant frequency.

Above and below the resonant frequency of any LC circuit, the circuit behaves as any standard AC circuit. Resonance is desired with radio frequencies in tuning receivers and transmitters, certain industrial equipment, and test equipment. It

is undesired in audio amplifiers and power supplies. Resonant circuits are not used in the audio bands of frequencies.

17-4 QUESTIONS

1. When does resonance occur?
2. Where are resonance circuits used?
3. What is the relationship between size of components and resonance frequencies?

SUMMARY

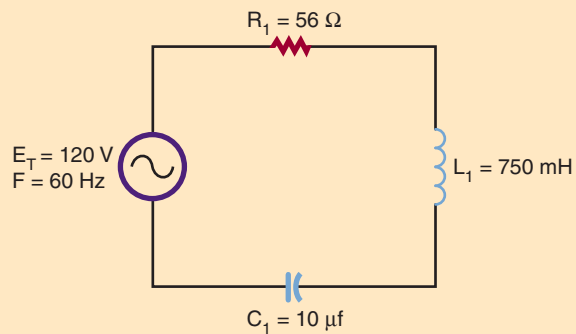
- Ohm's law applies to AC circuits, just as it does to DC circuits.
- The AC current lags the voltage by 90 degrees in an inductor (ELI).
- The AC current leads the voltage by 90 degrees in a capacitor (ICE).
- Vector representation allows the use of trigonometric functions to determine voltage or current when the phase angle is known.
- The combined effect of resistance and inductance or capacitance is called impedance.
- Apparent power is obtained by multiplying the source voltage and current with units of volt-amperes.
- The ratio of true power to apparent power in volts-amperes is called the power factor.
- Power factor is very important in the consideration of heavy industrial power distribution.
- Resonance circuits make it possible for a circuit to tune a station to a particular frequency.
- Resonance is desired for radio frequency in tuning circuits.

CHAPTER 17 SELF-TEST

1. What are the values of X_C , X_L , X , Z , and I_T for the circuit shown in Figure 17-16?

FIGURE 17-16

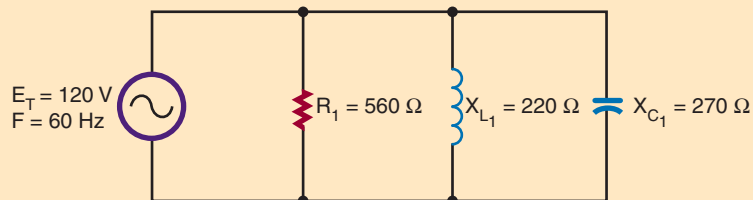
Series RLC circuit.



2. What are the values of I_C , I_L , I_X , I_R , and I_Z for the circuit shown in Figure 17-17?

FIGURE 17-17

Parallel RLC circuit.



Transformers

OBJECTIVES

After completing this chapter, the student should be able to:

- Describe how a transformer operates.
- Explain how transformers are rated.
- Explain how transformers operate in a circuit.
- Describe the differences between step-up, step-down, and isolation transformers.
- Describe how the ratio of the voltage, current, and number of turns are related with a transformer.
- Describe applications of a transformer.
- Identify different types of transformers.



See accompanying CD for Transformer examples in MultiSim, Chapter 18.

Transformers allow the transfer of an AC signal from one circuit to another. The transfer may involve stepping up the voltage, stepping down the voltage, or passing the voltage unchanged.

18-1 ELECTROMAGNETIC INDUCTION

If two electrically isolated coils are placed next to each other and an AC voltage is put across one coil, a changing magnetic field results. This changing magnetic field induces a voltage into the second coil. This action is referred to as

electromagnetic induction. The device is called a *transformer*.

In a transformer, the coil containing the AC voltage is referred to as the *primary winding*. The other coil, in which the voltage is induced, is referred to as the *secondary winding*. The amount of voltage induced depends on the amount of mutual induction between the two coils. The amount of mutual induction is determined by the coefficient of coupling. The *coefficient of coupling* is a number from 0 to 1, with 1 indicating that all the primary flux lines cut the secondary windings and 0 indicating that none of the primary flux lines cut the windings.

The design of a **transformer** is determined by the frequency at which it will be used, the power it must handle, and the voltage it must handle. For example, the application of the transformer determines the type of core material that the coils are wound on. For low-frequency applications, iron cores are used. For high-frequency applications, air cores are used. Air cores are nonmetallic cores used to reduce losses associated with the higher frequencies.

Transformers are rated in **volt-amperes (VA)** rather than in power (watts). This is because of the loads that can be placed on the secondary winding. If the load is a pure capacitive load, the reactance could cause the current to be excessive. The power rating has little meaning where a volt-ampere rating can identify the maximum current the transformer can handle.

Figure 18–1 shows the schematic symbol of a transformer. The direction of the primary and secondary windings on the core determines the polarity of the induced voltage in the secondary winding. The AC voltage can either be in phase or 180 degrees out of phase with the induced voltage. Dots are used on the schematic symbol of the transformer to indicate polarity.

Transformers are wound with tapped secondaries (Figure 18–2). A center-tapped secondary is the equivalent of two secondary windings, each with half of the total voltage across them. The center tap is used for power supply to convert AC voltages to DC voltages. A transformer may have

FIGURE 18–1
Transformer schematic symbol showing phase indication.

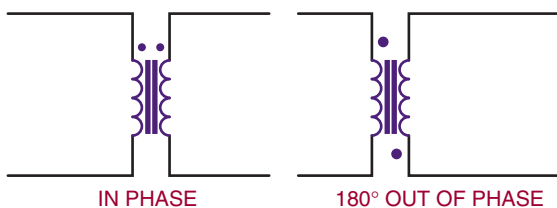
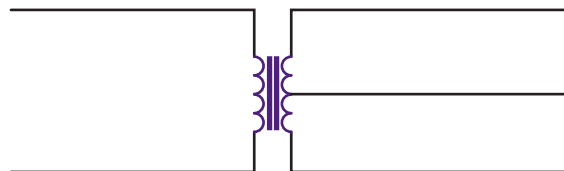
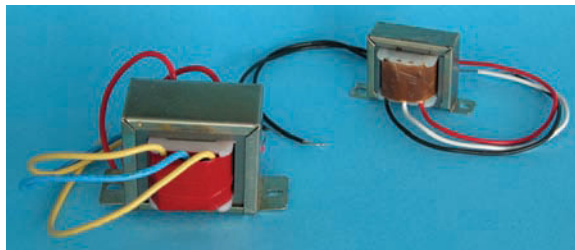


FIGURE 18–2
(A) Transformers with a center-tapped secondary.
(B) Schematic symbol showing transformer with a center-tapped secondary.



taps on the primary to compensate for line voltages that are too high or too low.

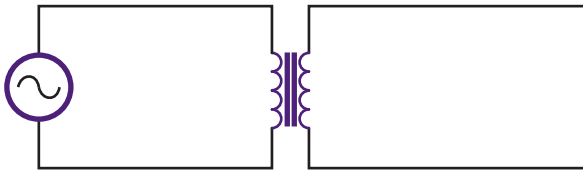
18–1 QUESTIONS

1. How does a transformer operate?
2. What determines the design of a transformer?
3. Give an example of how the application of a transformer determines its design.
4. How are transformers rated?
5. Draw and label the schematic symbol for a transformer.

18–2 MUTUAL INDUCTANCE

When a transformer is operated without a load (Figure 18–3) there is no secondary current flow. There is a primary current flow because the

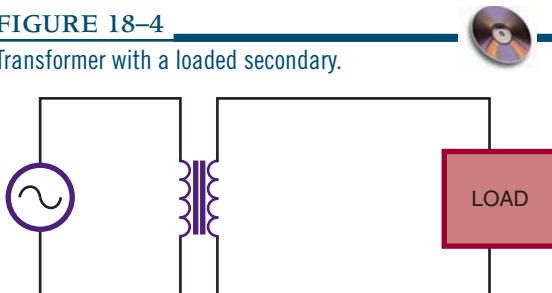
FIGURE 18-3
Transformer without a load on the secondary.



transformer is connected across a voltage source. The amount of primary current depends on the size of the primary windings. The primary windings act like an inductor. Exciting current is the small amount of primary current that flows. The exciting current overcomes the AC resistance of the primary winding and supports the magnetic field of the core. Because of inductive reactance, the exciting current lags behind the applied voltage. These conditions change when a load is applied across the secondary.

When a load is connected across the secondary winding (Figure 18-4) a current is induced into the secondary. Transformers are wound with the secondary on top of the primary. The magnetic field created by the primary current cuts the secondary windings. The current in the secondary establishes a magnetic field of its own. The expanding magnetic field in the secondary cuts the primary turns, inducing a voltage back into the primary. This magnetic field expands in the same direction as the current in the primary, aiding it

FIGURE 18-4
Transformer with a loaded secondary.



and causing it to increase, with an effect called **mutual inductance**. The primary induces a voltage into the secondary and the secondary induces a voltage back into the primary.

18-2 QUESTIONS

1. How does loading a transformer affect its operation?
2. Define *mutual inductance*.
3. Describe how a transformer induces a voltage back into its primary.

18-3 TURNS RATIO

The turns ratio of a transformer determines whether the transformer is used to step up, step down, or pass voltage unchanged. The **turns ratio** is the number of turns in the secondary winding divided by the number of turns in the primary winding. This can be expressed as:

$$\text{turns ratio} = \frac{N_S}{N_P}$$

where: N = number of turns

A transformer with secondary voltage greater than its primary voltage is called a **step-up transformer**. The amount the voltage is stepped up depends on the turns ratio. The ratio of secondary to primary voltage is equal to the ratio of secondary to primary turns. This is expressed as:

$$\frac{E_S}{E_P} = \frac{N_S}{N_P}$$

Thus the turns ratio of a step-up transformer is always greater than one.

EXAMPLE: A transformer has 400 turns on the primary and 1200 turns on the secondary. If 120 volts of AC current are applied across the primary, what voltage is induced into the secondary?

Given:

$$E_s = ?$$

$$E_p = 120 \text{ V}$$

$$N_s = 1200 \text{ turns}$$

$$N_p = 400 \text{ turns}$$

A transformer that produces a secondary voltage less than its primary voltage is called a **step-down transformer**. The amount the voltage is stepped down is determined by the turns ratio. In a step-down transformer the turns ratio is always less than one.

EXAMPLE: A transformer has 500 turns on the primary and 100 turns on the secondary. If 120 volts AC are applied across the primary, what is the voltage induced in the secondary?

Given:

$$E_s = ?$$

$$N_p = 500 \text{ turns}$$

$$N_s = 100 \text{ turns}$$

$$E_p = 120 \text{ V}$$

Assuming no transformer losses, the power in the secondary must equal the power in the primary. Although the transformer can step up voltage, it cannot step up power. The power removed from the secondary can never be more than the power supplied to the primary. Therefore, when a transformer steps up the voltage, it steps down the current so the output power remains the same. This can be expressed as:

$$P_p = P_s$$

$$(I_p)(E_p) = (I_s)(E_s)$$

The current is inversely proportional to the turns ratio. This can be expressed as:

$$\frac{I_p}{I_s} = \frac{N_s}{N_p}$$

Solution:

$$\frac{E_s}{E_p} = \frac{N_s}{N_p}$$

$$\frac{E_s}{120} = \frac{1200}{400}$$

$$E_s = 360 \text{ V}$$

EXAMPLE: A transformer has a 10:1 turns ratio. If the primary has a current of 100 milliamperes, how much current flows in the secondary?

NOTE: THE FIRST NUMBER IN THE RATIO REFERS TO THE PRIMARY, THE SECOND NUMBER TO THE SECONDARY.

Given:

$$I_s = ?$$

$$N_p = 10$$

$$N_s = 1$$

$$I_p = 100 \text{ mA} = 0.1 \text{ A}$$

Solution:

$$\frac{I_p}{I_s} = \frac{N_s}{N_p}$$

$$\frac{0.1}{I_s} = \frac{1}{10}$$

$$I_s = 1 \text{ A}$$

An important application of transformers is in impedance matching. Maximum power is transferred when the impedance of the load matches the impedance of the source. When the impedance does not match, power is wasted.

For example, if a transistor amplifier can efficiently drive a 100-ohm amplifier, it will not efficiently drive a 4-ohm speaker. A transformer used between the transistor amplifier and speaker can make the impedance of the speaker appear to be in proportion. This is accomplished by choosing the proper turns ratio.

The *impedance ratio* is equal to the turns ratio squared. This is expressed as:

$$\frac{Z_p}{Z_s} = \left(\frac{N_p}{N_s} \right)^2$$

EXAMPLE: What must the turns ratio of a transformer be to match a 4-ohm speaker to a 100-ohm source?

Given:

$$N_p = ?$$

$$N_s = ?$$

$$Z_p = 100$$

$$Z_s = 4$$

Solution:

$$\frac{Z_p}{Z_s} = \left(\frac{N_p}{N_s} \right)^2$$

$$\frac{100}{4} = \left(\frac{N_p}{N_s} \right)^2$$

$$\sqrt{25} = \frac{N_p}{N_s}$$

$$\frac{5}{1} = \frac{N_p}{N_s}$$

The turns ratio is 5:1.

18-3 QUESTIONS

1. What determines whether a transformer is a step-up or a step-down transformer?
2. Write the formula for determining the turns ratio of a transformer.
3. Write the formula for determining voltage based on the turns ratio of a transformer.
4. What is the secondary output of a transformer with 100 turns on the primary and 1800 turns on the secondary and 120 volts applied?

18-4 APPLICATIONS

Transformers have many applications. Among them are stepping up and stepping down voltage and current, impedance matching, phase shifting, isolation, blocking DC while passing AC, and producing several signals at various voltage levels.

Transmitting electrical power to homes and industry requires the use of transformers. Power stations are located next to sources of energy, and electrical power must often be transmitted over great distances. The wires used to carry the power have resistance, which causes power loss during the transmission. The power is equal to the current times the voltage:

$$P = IE$$

Ohm's law states that current is directly proportional to voltage and inversely proportional to resistance:

$$I = \frac{E}{R}$$

The amount of power lost, then, is proportional to the amount of resistance in the line. The

easiest way to reduce power losses is to keep the current low.

EXAMPLE: A power station produces 8500 volts at 10 amperes. The power lines have 100 ohms of resistance. What is the power loss of the lines?

Given:

$$P = ?$$

$$I = 10 \text{ A}$$

$$E = ?$$

$$R = 100 \Omega$$

Solution:

First, find the amount of voltage drop.

$$I = \frac{E}{R}$$

$$10 = \frac{E}{100}$$

$$E = 1000 \text{ V}$$

Using E, find the power loss.

$$P = IE$$

$$P = (10)(1000)$$

$$P = 10,000 \text{ W}$$

Using a transformer to step the voltage up to 85,000 volts at 1 ampere, what is the power loss?

Given:

$$I = 1 \text{ A}$$

$$E = ?$$

$$R = 100 \Omega$$

Solution:

First, find the amount of voltage drop.

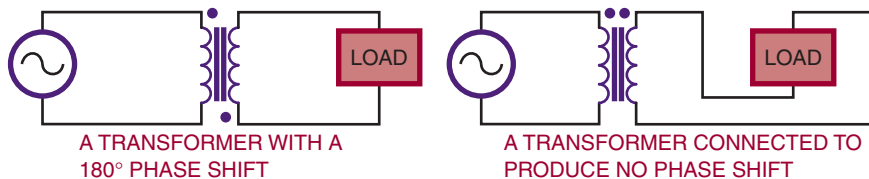
$$I = \frac{E}{R}$$

$$1 = \frac{E}{100}$$

$$E = 100 \text{ V}$$

FIGURE 18-5

A transformer can be used to generate a phase shift.



Using E, find the power loss.

$$P = IE$$

$$P = (1)(100)$$

$$P = 100 \text{ W}$$

How the transformer is wound determines whether it produces a phase shift or not. The application determines how important the phase shift is (Figure 18-5).

NOTE: THE PHASE CAN BE SHIFTED BY SIMPLY REVERSING THE LEADS TO THE LOAD

If DC voltage is applied to a transformer, nothing occurs in the secondary once the magnetic field is established. A changing current is necessary to induce a voltage in the secondary. A transformer can be used to isolate the secondary from any DC voltage in the primary (Figure 18-6).

Transformers are used to isolate electronic equipment from 120-volts AC, 60-hertz power while it is being tested (Figure 18-7). The reason for using a transformer is to prevent shocks. Without the transformer, one side of the power source is connected to the chassis. When the chassis is re-

FIGURE 18-6

A transformer can be used to block DC voltage.

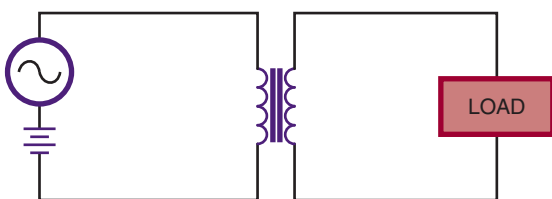
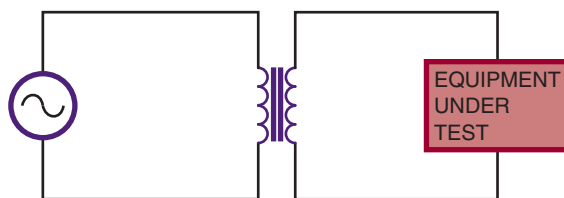


FIGURE 18-7

An isolation transformer prevents electrical shock by isolating the equipment from ground.



moved from the cabinet, the “hot” chassis presents a shock hazard. This condition is more likely to occur if the power cord can be plugged in either way. A transformer prevents connecting either side of the equipment to ground. An **isolation transformer** does not step up or step down the voltage.

An **autotransformer** is a device used to step up or step down applied voltage. It is a special type of transformer in which the primary and secondary windings are both part of the same core. Figure 18-8A shows an autotransformer stepping down a voltage. Because the secondary consists of fewer turns, the voltage is stepped down. Figure 18-8B shows an autotransformer stepping up a voltage. Because the secondary has more turns than the primary, the voltage is stepped up. A disadvantage of the autotransformer is that the secondary is not isolated from the primary. The advantage is that the autotransformer is cheaper and easier to construct than a transformer.

A special type of autotransformer is a variable autotransformer, in which the load is connected to a movable arm and one side of the autotrans-

FIGURE 18-8

An autotransformer is a special type of transformer used to step up or step down the voltage.

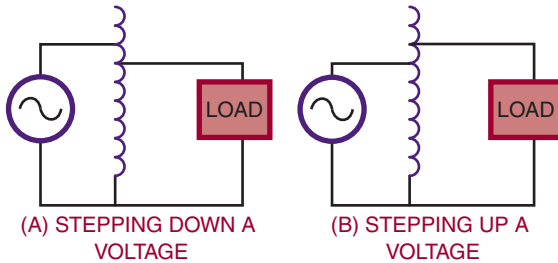


FIGURE 18-9

A variable autotransformer.



former (Figure 18-9). Moving the arm varies the turns ratio, producing a change in the voltage across the load. The output voltage can be varied from 0 to 130 VAC.

18-4 QUESTIONS

1. What are the applications of transformers?
2. How are transformers used in transmitting electrical power to the home?

3. How can a transformer produce a phase shift of the input signal?
4. Why are isolation transformers important when working on electronic equipment?
5. What is an autotransformer used for?

SUMMARY

- A transformer consists of two coils, a primary winding and a secondary winding.
- An AC voltage is put across the primary winding, inducing a voltage in the secondary winding.
- Transformers allow an AC signal to be transferred from one circuit to another.
- Transformers allow stepping up, stepping down, or passing the signal unchanged.
- Transformers are designed to operate at certain frequencies.
- Transformers are rated in volt-amperes (VA).
- The schematic symbol used for iron-core transformers is:



- The turns ratio determines whether a transformer is used to step up, step down, or pass voltage unchanged.

$$\text{turns ratio} = \frac{N_S}{N_P}$$

- The ratio of secondary to primary voltage is equal to the ratio of secondary to primary turns.

$$\frac{E_S}{E_P} = \frac{N_S}{N_P}$$

- A transformer that produces a secondary voltage greater than its primary voltage is called a step-up transformer.

- The turns ratio of a step-up transformer is always greater than 1.
- A transformer that produces a secondary voltage less than its primary voltage is called a step-down transformer.
- The turns ratio of a step-down transformer is always less than 1.
- The amount the voltage is stepped up or down is determined by the turns ratio.
- Transformer applications include: impedance matching, phase shifting, isolation, blocking DC while passing AC, and producing several signals at different voltage levels.
- An isolation transformer passes the signal unchanged.
- An isolation transformer is used to prevent electric shocks.
- An autotransformer is used to step up or step down voltage.
- An autotransformer is a special transformer that does not provide isolation.

CHAPTER 18 SELF-TEST

1. Explain how electromagnetic induction induces a voltage into the secondary of a transformer.
2. Why are transformers rated in volt-amperes rather than watts?
3. What is the difference between two transformers, one that has voltage applied to the primary without a load on the secondary and one that has a load on the secondary?
4. What turns ratio is required on the secondary of a transformer if the primary has 400 turns? The applied voltage is 120 VAC and the secondary voltage is 12 V.
5. What turns ratio is required for an impedance-matching transformer to match a 4-ohm speaker to a 16- Ω source?
6. Explain why transformers are important for transmitting electrical power to residential and industrial needs.
7. How does an isolation transformer prevent electrical shock?

SECTION 2 ACTIVITY—AC CIRCUITS

1. Use various pieces of test equipment to check if a circuit is working. Draw input and output waveforms.
2. Use MultiSIM to emulate various circuits and test equipment displays.
3. Design and build a tester that can provide a visual reading for a 120/240-V single phase circuit.
4. Using fellow students, form a product development team. Assess each other's strengths. Identify who will fill the roles that will be needed to sustain a productive team; (i.e. leadership, thinking, technical, bilingual, marketing, etc. . .) and form the team.
5. Using available test instruments, develop a set of quality standards and criteria that apply to the electricity that your laboratory uses. Develop a plan that you can implement that monitors these quality factors and how they can be improved upon.
6. Using a development team, prepare a report or presentation electronically, (i.e. PowerPoint) that outlines the current trends in the semiconductor manufacturing industry. Use graphics to clearly illustrate the process.

This page intentionally left blank

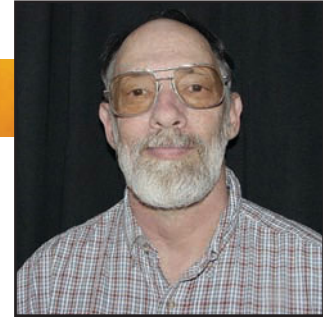
SECTION 3

Semiconductor Devices



CAREER PROFILE

Ronald G. Walls



TITLE

Station Manager

EMPLOYER

Broadcast Television Station TV24

BACKGROUND

Ron began his preparation right after graduating from high school when he attended the David Rankin School of Mechanical Trades and completed a two-year program of study in electronic communication and computer technology. Upon graduation, Ron secured a position in the videotape division of Ampex Corporation. He then enlisted in the U.S. Navy, where he completed advanced training in electronics. Ron spent four years in the navy teaching electronics at the Great Lakes Naval Training Command. He held various positions in radio and television after leaving the navy and simultaneously completed additional specialized education programs in electronics, becoming certified by the International Society of Certified Electronics Technicians (ISCET). Ron later taught electronics, robotics, and electrical engineering technology at technical institutes and community colleges before becoming the station manager for Broadcast Television Station TV24.

JOB REQUIREMENTS

Associate Degree in Electronics or a technical certificate and on-the-job training.

ON THE JOB

Working as the station manager of a small television station involves ensuring FCC license compliance, producing or procuring program content, scheduling programs, public relations, personnel management, and soliciting advertising. Much of what it takes to be a successful station manager is learned on the job. However, to even get started, one must have a solid background in television-related electronics and must keep up-to-date in this field. Everything else the manager of a small television station must do is based on having this foundational knowledge of electronics.

UPSIDE

Though the pace can be hectic, the rewards can be great. As a member of the electronic media, many opportunities arise that are not available to people in other positions. These include opportunities to meet American presidents, presidential candidates, other political figures, movie stars, and renowned athletes.

DOWNSIDE

Working in the television industry can mean long hours seven days a week and 365 days a year. It is easy to “burn out” unless you pace yourself. There are days when you would give almost anything for just five minutes of peace and quiet. Then there are days or even longer periods when it seems nothing newsworthy is going to happen.

OPPORTUNITIES

The television industry is filled with opportunities for electronics technicians. Television employs many different kinds of electronics technicians including camera, video, and computer technicians; equipment installation, service, and repair technicians; network and computer technicians; communications technicians; and electrical/electronics engineering technicians and technologists.

WORDS OF ADVICE

As an electronics technician, an electronics instructor, and a television station manager, I learned that flexibility is critical to long-term success in the broad field of electronics. Things change quickly and continually in electronics, so there is a constant need to learn and adapt. However, with a solid understanding of basic electronics principles you can continue to learn, grow, and adapt over a lifetime and enjoy a successful career.

Semiconductor Fundamentals

OBJECTIVES

After completing this chapter, the student should be able to:

- Identify materials that act as semiconductors.
- Define *covalent bonding*.
- Describe the doping process for creating N- and P-type semiconductor materials.
- Explain how doping supports current flow in a semiconductor material.

Semiconductors are the basic components of electronic equipment. The more commonly used semiconductors are the *diode* (used to rectify), the *transistor* (used to amplify), and the *integrated circuit* (used to switch or amplify). The primary function of semiconductor devices is to control voltage or current for some desired result.

Advantages of semiconductors include the following:

- Small size and weight
- Low power consumption at low voltages
- High efficiency
- Great reliability
- Ability to operate in hazardous environments
- Instant operation when power is applied
- Economic mass production

Disadvantages of semiconductors include:

- Great susceptibility to changes in temperature
- Extra components required for stabilization
- Easily damaged (by exceeding power limits, by reversing polarity of operating voltage, by excess heat when soldering into circuit)

19-1 SEMICONDUCTION IN GERMANIUM AND SILICON

Semiconductor materials have characteristics that fall between those of insulators and conductors. Three pure semiconductor elements are carbon (C), germanium (Ge), and silicon (Si). Those suitable for electronic applications are germanium and silicon.

Germanium is a brittle, grayish-white element discovered in 1886. A powder, germanium dioxide, is recovered from the ashes of certain types of coal. The powder is then reduced to the solid form of pure germanium.

Silicon was discovered in 1823. It is found extensively in the earth's crust as a white or sometimes colorless compound, silicon dioxide.

Silicon dioxide (silica) can be found abundantly in sand, quartz, agate, and flint. It is then chemically reduced to pure silicon in a solid form. Silicon is the most commonly used semiconductor material.

Once the pure or **intrinsic material** is available, it must be modified to produce the qualities necessary for semiconductor devices.

As described in Chapter 1, the center of the atom is the nucleus, which contains protons and neutrons. The protons have a positive charge and the neutrons have no charge. Electrons orbit around the nucleus and have a negative charge. Figure 19-1 shows the structure of the silicon atom. The first orbit contains two electrons, the second orbit contains eight electrons, and the outer orbit, or valence shell, contains four electrons. **Valence** is an indication of the atom's ability to gain or lose electrons and deter-

FIGURE 19-1

Atomic structure of silicon.

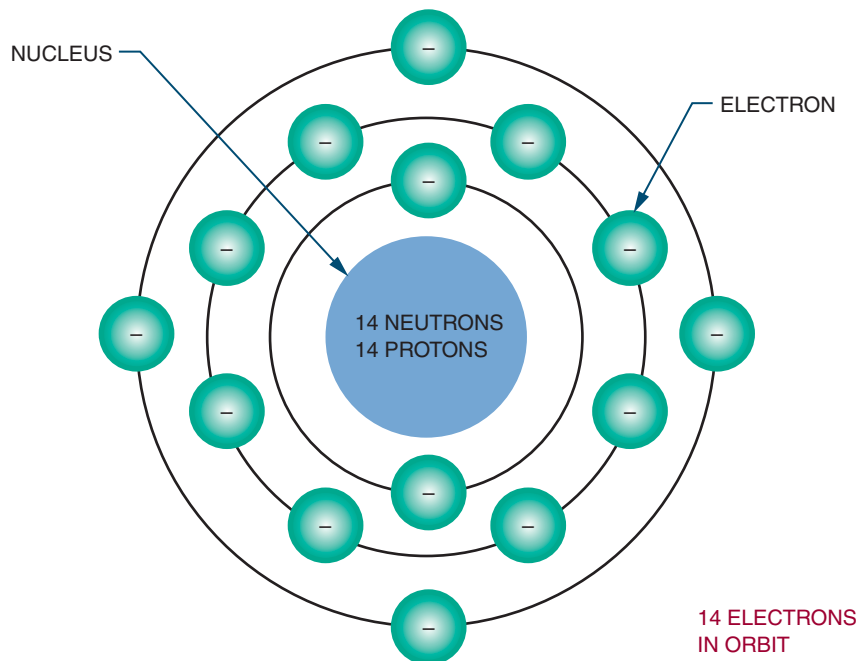
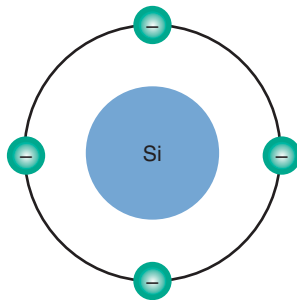


FIGURE 19-2

Simplified silicon atom shown with only valence electrons.



mines the electrical and chemical properties of the atom. Figure 19-2 shows a simplified drawing of the silicon atom, with only the four electrons in the valence shell.

Materials that need electrons to complete their valence shell are not stable and are referred to as *active materials*. To gain stability, an active material must acquire electrons in its valence shell. Silicon atoms are able to share their valence electrons with other silicon atoms in a process called covalent bonding (Figure 19-3). **Covalent bonding** is the process of sharing valence electrons, resulting in the formation of crystals.

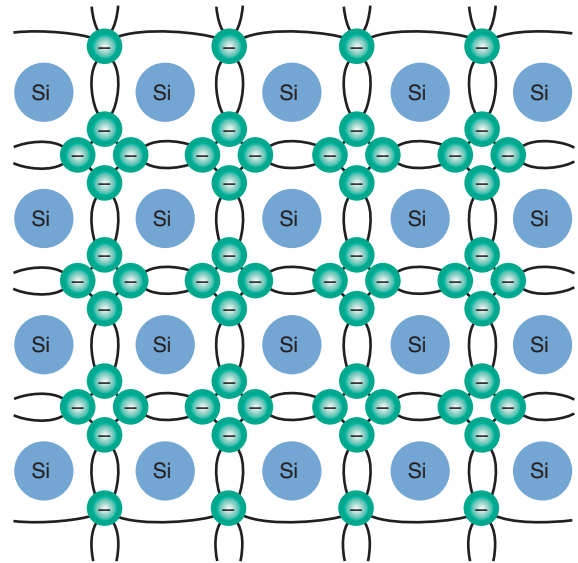
Each atom in such a crystalline structure has four of its own electrons and four shared electrons from four other atoms—a total of eight valence electrons. This covalent bond cannot support electrical activity because of its stability.

At room temperature, pure silicon crystals are poor conductors. They behave like insulators. If heat energy is applied to the crystals, however, some of the electrons absorb the energy and move to a higher orbit, breaking the covalent bond. This allows the crystals to support current flow.

Silicon, like other semiconductor materials, is said to have a **negative temperature coefficient** because as the temperature increases, its resistance decreases. The resistance is cut in half for every 6 degrees celsius of rise in temperature.

FIGURE 19-3

Crystalline structure of silicon with covalent bonding.



Like silicon, germanium has four electrons in its valence shell and can form a crystalline structure. Germanium's resistance is cut in half for every 10 degrees celsius of temperature rise. Thus germanium appears to be more stable with respect to temperature change than silicon. However, germanium requires less heat energy to dislodge its electrons than does silicon. Silicon has a thousand times more resistance than germanium at room temperature.

Heat is a potential source of trouble for semiconductors that is not easy to control. Good circuit design minimizes heat changes. Its resistance is what makes silicon preferable to germanium in most circuits. In some applications, heat-sensitive devices are necessary. In these applications the germanium temperature coefficient can be an advantage; therefore, germanium is used.

All early transistors were made of germanium. The first silicon transistor was not made until 1954. Today, silicon is used for most solid-state applications.

19-1 QUESTIONS

1. What is a semiconductor material?
2. Define the following terms:
 - a. Covalent bonding
 - b. Negative temperature coefficient
3. Why are silicon and germanium considered semiconductor materials?
4. Why is silicon preferred over germanium?

19-2 CONDUCTION IN PURE GERMANIUM AND SILICON

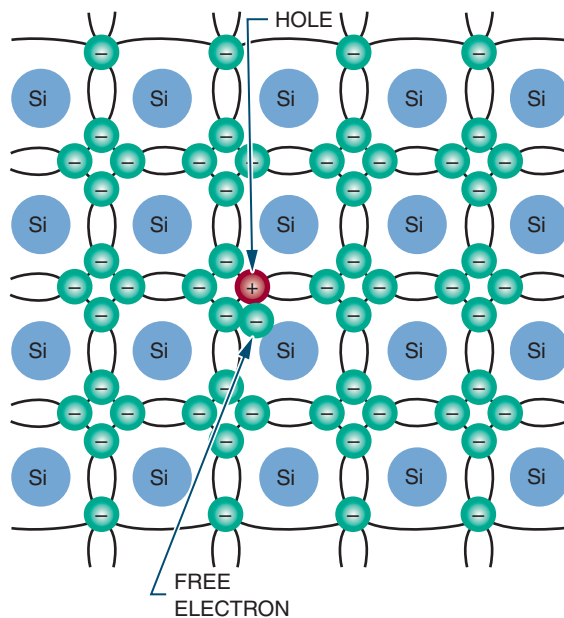
The electrical activity in semiconductor material is highly dependent on temperature. At extremely low temperatures, valence electrons are held tightly to the parent atom through the covalent bond. Because these valence electrons cannot drift, the material cannot support current flow. Germanium and silicon crystals function as insulators at low temperatures.

As the temperature increases, the valence electrons become agitated. Some of the electrons break the covalent bonds and drift randomly from one atom to the next. These free electrons are able to carry a small amount of electrical current if an electrical voltage is applied. At room temperature, enough heat energy is available to produce a small number of free electrons and to support a small amount of current. As the temperature increases, the material begins to acquire the characteristics of a conductor. Only at extremely high temperatures does silicon conduct current as ordinary conductors do. Typically, such high temperatures are not encountered under normal usage.

When an electron breaks away from its covalent bond, the space previously occupied by the

FIGURE 19-4

A hole is created when an electron breaks its covalent bond.



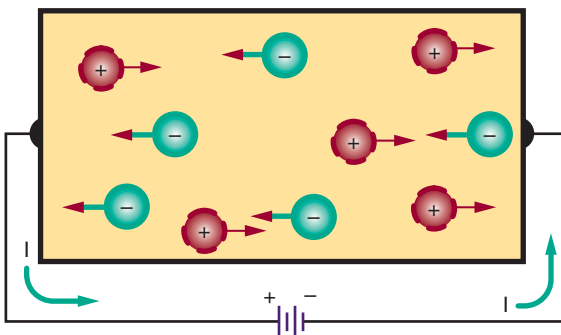
electron is referred to as a hole (Figure 19-4). As described in Chapter 2, a **hole** simply represents the absence of an electron. Because an electron has a negative charge, its absence represents the loss of a negative charge. A hole thus has the characteristic of a positively charged particle. As an electron jumps from one valence shell to another valence shell with a hole, it leaves a hole behind it. If this action continues, the hole appears to move in the opposite direction to the electron.

Each corresponding electron and hole are referred to as an *electron-hole pair*. The number of electron-hole pairs increases with an increase in temperature. At room temperature a small number of electron-hole pairs exist.

When pure semiconductor material is subjected to a voltage, the free electrons are attracted to the positive terminal of the voltage

FIGURE 19-5

Current flow in pure semiconductor material.



source (Figure 19-5). The holes created by movement of the free electrons drift toward the negative terminal. As the free electrons flow into the positive terminal, an equal number leave the negative terminal. As the holes and electrons recombine, both holes and free electrons cease to exist.

In review, holes constantly drift toward the negative terminal of the voltage source. Electrons always flow toward the positive terminal. Current flow in a semiconductor consists of the movement of both electrons and holes. The amount of current flow is determined by the number of electron-hole pairs in the material. The ability to support current flow increases with the temperature of the material.

19-2 QUESTIONS

1. How can pure germanium support a current flow?
2. When a potential is applied to pure germanium, in what direction do the electrons and holes move?
3. What determines the amount of current flow in a pure semiconductor material?

19-3 CONDUCTION IN DOPED GERMANIUM AND SILICON

Pure semiconductors are mainly of theoretical interest. Development and research are concerned with the effects of adding impurities to pure materials. If it were not for these impurities, most semiconductors would not exist.

Pure semiconductor materials, such as germanium and silicon, support only a small number of electron-hole pairs at room temperature. This allows for conduction of very little current. To increase their conductivity, a process called doping is used.

Doping is the process of adding impurities to a semiconductor material. Two types of impurities are used. The first, called **pentavalent**, is made of atoms with five valence electrons. Examples are arsenic and antimony. The other, called **trivalent**, is made of atoms with three valence electrons. Examples are indium and gallium.

When pure semiconductor material is doped with a pentavalent material such as arsenic (As), some of the existing atoms are displaced with arsenic atoms (Figure 19-6). The arsenic atom shares four of its valence electrons with adjacent silicon atoms in a covalent bond. Its fifth electron is loosely attached to the nucleus and is easily set free.

The arsenic atom is referred to as a *donor atom* because it gives its extra electron away. There are many donor atoms in a semiconductor material that has been doped. This means that many free electrons are available to support current flow.

At room temperature the number of donated free electrons exceeds the number of electron-hole pairs. This means that there are more electrons than holes. The electrons are therefore called the *majority carrier*. The holes are *minority carriers*. Because the negative charge is the majority carrier, the material is called *N-type*.

FIGURE 19-6
Silicon semiconductor material doped with an arsenic atom.

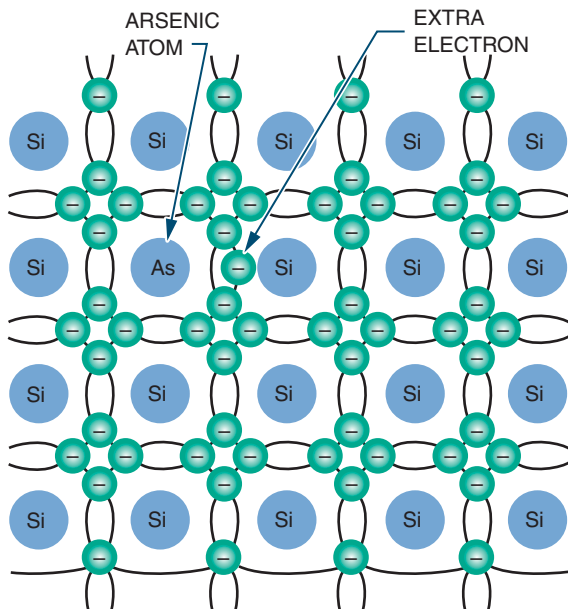
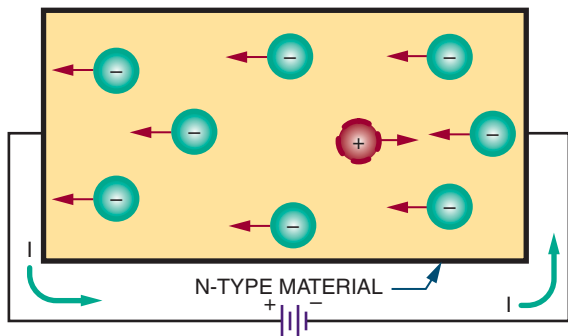
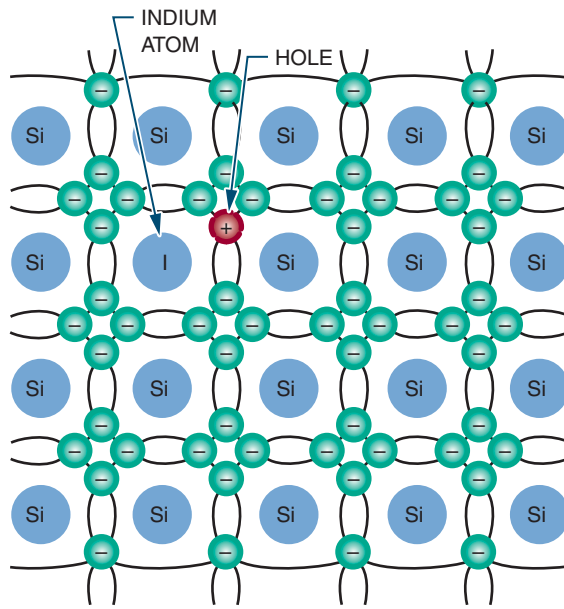


FIGURE 19-7
Current flow in N-type material.



If voltage is applied to **N-type material** (Figure 19-7) the free electrons contributed by the donor atoms flow toward the positive terminal. Additional electrons break away from their covalent bonds and flow toward the positive ter-

FIGURE 19-8
Silicon semiconductor material doped with an indium atom.



minal. These free electrons, in breaking their covalent bonds, create electron-hole pairs. The corresponding holes move toward the negative terminal.

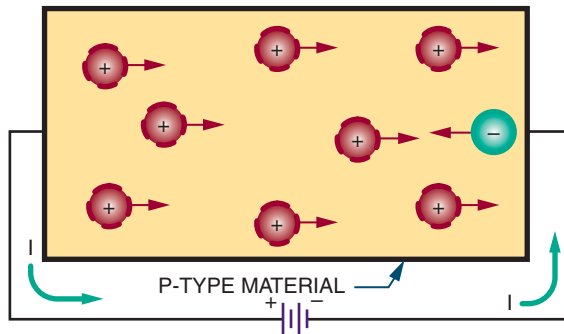
When semiconductor materials are doped with trivalent materials such as indium (I), the indium atom shares its three valence electrons with three adjacent atoms (Figure 19-8). This creates a hole in the covalent bond.

The presence of additional holes allows the electrons to drift easily from one covalent bond to the next. Because holes easily accept electrons, atoms that contribute extra holes are called *acceptor atoms*.

Under normal conditions, the number of holes greatly exceeds the number of electrons in such material. Therefore, the holes are the majority carrier and the electrons are the minority carrier. Because the positive charge is the majority carrier, the material is called **P-type material**.

FIGURE 19-9

Current flow in P-type material.



If voltage is applied to P-type material, it causes the holes to move toward the negative terminal and the electrons to move toward the positive terminal (Figure 19-9). In addition to the holes provided by the acceptor atom, holes are produced as electrons break away from their covalent bonds, creating electron-hole pairs.

N- and P-type semiconductor materials have much higher conductivity than pure semiconductor materials. This conductivity can be increased or decreased by the addition or deletion of impurities. The more heavily a semiconductor material is doped, the lower its electrical resistance.

19-3 QUESTIONS

1. Describe the process of doping a semiconductor material.
2. What are the two types of impurities used for doping?
3. What determines whether a material, when doped, is an N-type or P-type semiconductor material?
4. How does doping support current flow in a semiconductor material?
5. What determines the conductivity of a semiconductor material?

SUMMARY

- Semiconductor materials are any materials with characteristics that fall between those of insulators and conductors.
- Pure semiconductor materials are germanium (Ge), silicon (Si), and carbon (C).
- Silicon is used for most semiconductor devices.
- Valence is an indication of an atom's ability to gain or lose electrons.
- Semiconductor materials have valence shells that are half full.
- Crystals are formed by atoms sharing their valence electrons through covalent bonding.
- Semiconductor materials have a negative temperature coefficient: As the temperature rises, their resistance decreases.
- Heat creates problems with semiconductor materials by allowing electrons to break their covalent bonds.
- As the temperature increases in a semiconductor material, electrons drift from one atom to another.
- A hole represents the absence of an electron in the valence shell.
- A difference of potential, applied to pure semiconductor material, creates a current flow toward the positive terminal and a hole flow toward the negative terminal.
- Current flow in semiconductor materials consists of both electron flow and hole movement.
- Doping is the process of adding impurities to a semiconductor material.
- Pentavalent materials have atoms with five valence electrons and are used to make N-type material.
- Trivalent materials have atoms with three valence electrons and are used to make P-type material.
- In N-type material, electrons are the majority carrier and holes are the minority carrier.

- In P-type material, holes are the majority carrier and electrons are the minority carrier.
- N- and P-type semiconductor materials have a higher conductivity than pure semiconductor materials.

CHAPTER 19 SELF-TEST

1. What makes silicon more desirable to use than germanium?
2. Why is covalent bonding important in the formation of semiconductor materials?
3. Describe how an electron travels through a block of pure silicon at room temperature.
4. Describe the process of converting a block of pure silicon to N-type material.
5. Describe what happens to a block of N-type material when a voltage is applied.

PN Junction Diodes

OBJECTIVES

After completing this chapter, the student should be able to:

- Describe what a junction diode is and how it is made.
- Define *depletion region* and *barrier voltage*.
- Explain the difference between forward bias and reverse bias of a diode.
- Draw and label the schematic symbol for a diode.
- Describe three diode construction techniques.
- Identify the most common diode packages.
- Test diodes using an ohmmeter.

Diodes are the simplest type of semiconductor. They allow current to flow in only one direction. The knowledge of semiconductors that is acquired by studying diodes is also applicable to other types of semiconductor devices.



See accompanying CD for PN Junction Diode examples in MultiSim, in Chapter 20.

20-1 PN JUNCTIONS

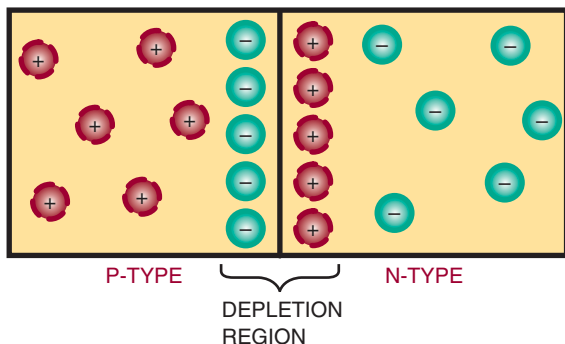
When pure or intrinsic semiconductor material is doped with a pentavalent or trivalent material, the doped material is called N- or P-type based on the majority carrier. The electrical charge of each type is neutral because each atom contributes an equal number of protons and electrons.

Independent electrical charges exist in each type of semiconductor material, because electrons are free to drift. The electrons and holes that drift

are referred to as *mobile charges*. In addition to the mobile charges, each atom that gains an electron has more electrons than protons and assumes a negative charge. Similarly, each atom that loses an electron has more protons than electrons and therefore assumes a positive charge. As described in Chapter 1, these individual charged atoms are called negative and positive ions. There is always an equal number of mobile and ionic charges within N-type and P-type semiconductor materials.

FIGURE 20-1

Diode formed by joining P- and N-type material to form a PN junction.



A **diode** is created by joining N- and P-type materials together (Figure 20-1). Where the materials come in contact with each other, a junction is formed. This device is referred to as a *junction diode*.

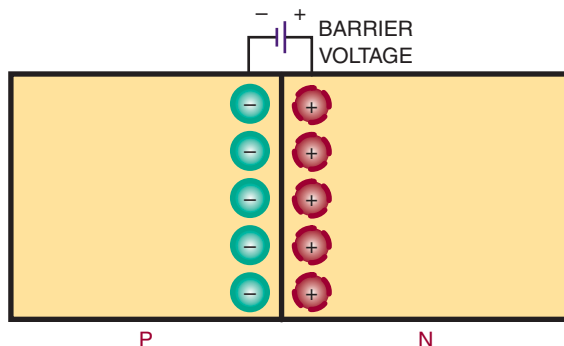
When the junction is formed, the mobile charges in the vicinity of the junction are strongly attracted to their opposites and drift toward the junction. As the charges accumulate, the action increases. Some electrons move across the junction and fill some of the holes near the junction in the P-type material. In the N-type material, the electrons become depleted near the junction. This region near the junction where the electrons and holes are depleted is called the **depletion region**. It extends only a short distance on either side of the junction.

There are no majority carriers in the depletion region, and the N-type and P-type materials are no longer electrically neutral. The N-type material takes on a positive charge near the junction, and the P-type material takes on a negative charge.

The depletion region does not get larger. The combining action tapers off quickly and the region remains small. The size is limited by the opposite charges that build up on each side of the junction. As the negative charge builds up, it repels further electrons and keeps them from cross-

FIGURE 20-2

Barrier voltage as it exists across a PN junction.



ing the junction. The positive charge absorbs free electrons and aids in holding them back.

These opposite charges that build up on each side of the junction create a voltage, referred to as the **barrier voltage**. It can be represented as an external voltage source, even though it exists across the PN junction (Figure 20-2).

The barrier voltage is quite small, measuring only several tenths of a volt. Typically, the barrier voltage is 0.3 V for a germanium PN junction and 0.7 V for a silicon PN junction. This voltage becomes apparent when an external voltage source is applied.

20-1 QUESTIONS

- Define the following terms:
 - Donor atom
 - Acceptor atom
 - Diode
- What occurs when an N-type material is joined with a P-type material?
- How is the depletion region formed?
- What is the barrier voltage?
- What are typical barrier voltages for a germanium and a silicon diode?

20-2 DIODE BIASING

When a voltage is applied to a diode, it is referred to as a **bias voltage**. Figure 20-3 shows a PN junction diode connected to a voltage source. A resistor is added for limiting current to a safe value.

In the circuit shown, the negative terminal of the voltage source is connected to the N-type material. This forces electrons away from the terminal, toward the PN junction. The free electrons that accumulate on the P side of the junction are attracted by the positive terminal. This action cancels the negative charge on the P side, the barrier voltage is eliminated, and a current is able to flow. Current flow occurs only if the external voltage is greater than the barrier voltage.

The voltage source supplies a constant flow of electrons, which drift through the N-type material along with the free electrons contained in it. Holes in the P material also drift toward the junction. The holes and electrons combine at the junction and appear to cancel each other. However, as the electrons and holes combine, new electrons and holes appear at the terminals of the voltage source. The majority carriers continue to move toward the PN junction as long as the voltage source is applied.

Electrons flow through the P side of the diode, attracted by the positive terminal of the voltage source. As electrons leave the P material, holes are created that drift toward the PN junction where

they combine with other electrons. When the current flows from the N-type toward the P-type material, the diode is said to have a **forward bias**.

The current that flows when a diode is forward biased is limited by the resistance of the P and N materials and the external resistance of the circuit. The diode resistance is small. Therefore, connecting a voltage directly to a forward-biased diode creates a large current flow. This can generate enough heat to destroy the diode. To limit the forward current flow, an external resistor must be connected in series with the diode.

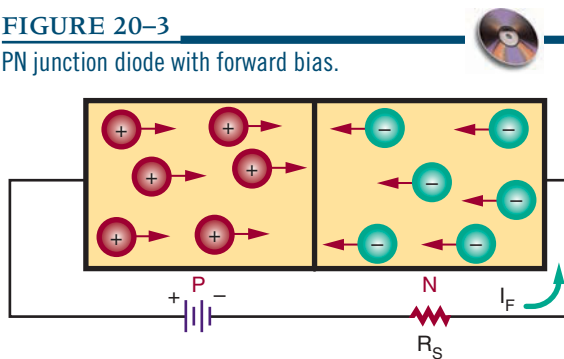
A diode conducts current in the forward direction only if the external voltage is larger than the barrier voltage and is connected properly. A germanium diode requires a minimum forward bias of 0.3 V; a silicon diode requires a minimum forward bias of 0.7 V.

Once a diode starts conducting, a voltage drop occurs. This voltage drop is equal to the barrier voltage and is referred to as the **forward voltage drop** (E_F). The voltage drop is 0.3 V for a germanium diode and 0.7 V for a silicon diode. The amount of forward current (I_F) is a function of the external voltage (E), the forward voltage drop (E_F), and the external resistance (R). The relationship can be shown using Ohm's law:

$$I = \frac{E}{R}$$

$$I_F = \frac{E - E_F}{R}$$

FIGURE 20-3
PN junction diode with forward bias.



EXAMPLE: A silicon diode has an external bias voltage of 12 V with an external resistor of 150 Ω . What is the total forward current?

Given:

$$I_F = ?$$

$$E = 12 \text{ V}$$

$$R = 150 \Omega$$

$$E_F = 0.7 \text{ V}$$

Solution:

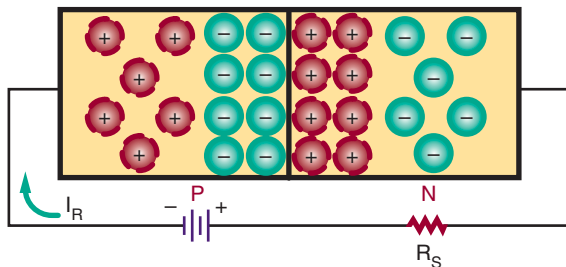
$$I_F = \frac{E - E_F}{R}$$

$$I_F = \frac{12 - 0.7}{150}$$

$$I_F = 0.075 \text{ A}$$

$$\text{or } 75 \text{ mA}$$

FIGURE 20-4
PN junction diode with reverse bias.



In a diode that is forward biased, the negative terminal of the external voltage source is connected to the N material, and the positive terminal is connected to the P material. If these terminals are reversed, the diode does not conduct and is said to be connected in **reverse bias** (Figure 20-4). In this configuration, the free electrons in the N material are attracted toward the positive terminal of the external voltage source. This increases the number of positive ions in the area of the PN junction, which increases the width of the depletion region on the N side of the junction. Electrons also leave the negative terminal of the voltage source and enter the P material. These electrons fill holes near the PN junction, causing the holes to move toward the negative terminal, which increases the width of the depletion region on the P side of the junction. The overall effect is that the depletion region is wider than in an unbiased or forward-biased diode.

The reverse-biased voltage increases the barrier voltage. If the barrier voltage is equal to the external voltage source, holes and electrons cannot support current flow. A small current flows with a reverse bias applied. This leakage current is referred to as **reverse current** (I_R) and exists because of minority carriers. At room temperature the minority carriers are few in number. As the temperature increases, more electron-hole pairs are created. This increases the number of majority carriers and the leakage current.

All PN junction diodes produce a small leakage current. In germanium diodes it is measured in microamperes; in silicon diodes it is measured in nanoamperes. Germanium has more leakage current because it is more sensitive to temperature. This disadvantage of germanium is offset by its smaller barrier voltage.

In summary, a PN junction diode is a one-directional device. When it is forward biased, a current flows. When it is reverse biased, only a small leakage current flows. It is this characteristic that allows the diode to be used as a rectifier. A rectifier converts an AC voltage to a DC voltage.

20-2 QUESTIONS

1. What is a bias voltage?
2. What is the minimum amount of voltage needed to produce current flow across a PN junction diode?
3. What is the difference between forward and reverse biasing?
4. What is leakage current in a PN junction diode?

20-3 DIODE CHARACTERISTICS

Both germanium and silicon diodes can be damaged by excessive heat and excessive reverse voltage. Manufacturers specify the maximum forward current ($I_F \text{ max}$) that can be handled safely. They also specify the maximum-safe reverse voltage (**peak inverse voltage**, or **PIV**). If the PIV is exceeded, a large reverse current flows, creating excess heat and damaging the diode.

At room temperature, the reverse current is small. As the temperature increases, the reverse current increases, interfering with proper operation of the diode. In germanium diodes, the reverse current is higher than in silicon diodes,

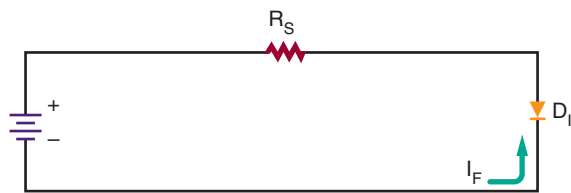
FIGURE 20-5

Diode schematic symbol.



FIGURE 20-6

Diode connected with forward bias.



doubling with approximately every 10°C of increased temperature.

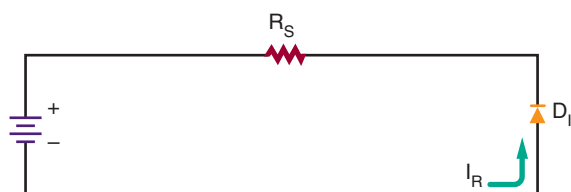
The diode symbol is shown in Figure 20-5. The P section is represented by an arrow, and the N section by a bar. Forward current flows from the N section to the P section (against the arrow). The N section is called the *cathode*, and the P section is called the *anode*. The cathode supplies and the anode collects the electrons.

Figure 20-6 shows a properly connected forward-biased diode. The negative terminal is connected to the cathode. The positive terminal is connected to the anode. This setup conducts a forward current. A resistor (R_S) is added in series to limit the forward current to a safe value.

Figure 20-7 shows a diode connected in reverse bias. The negative terminal is connected to

FIGURE 20-7

Diode connected with reverse bias.



the anode. The positive terminal is connected to the cathode. In reverse bias, a small reverse current (I_R) flows.

20-3 QUESTIONS

1. What problem can a reverse current create in a germanium or silicon diode?
2. Draw and label the schematic symbol for a diode.
3. Draw a circuit that includes a forward-biased diode.
4. Draw a circuit that includes a reverse-biased diode.
5. Why should a resistor be connected in series with a forward-biased diode?

20-4

DIODE CONSTRUCTION TECHNIQUES

The PN junction of a diode may be one of three types: a grown junction, an alloyed junction, or a diffused junction. Each involves a different construction technique.

In grown junction method (the earliest technique used) intrinsic semiconductor material and P-type impurities are placed in a quartz container and heated until they melt. A small semiconductor crystal, called a seed, is then lowered into the molten mixture. The seed crystal is slowly rotated and withdrawn from the molten mixture slowly enough to allow the molten mixture to cling to the seed. The molten mixture, clinging to the seed crystal, cools and rehardens, assuming the same crystalline characteristics as the seed. As the seed crystal is withdrawn, it is alternately doped with N- and P-type impurities. *Doping* is the process of adding impurities to pure semiconductor crystals to increase the number of free electrons or the

number of holes. This creates N and P layers in the crystal as it is grown. The resulting crystal is then sliced into many PN sections.

The alloyed junction method of forming a semiconductor is extremely simple. A small pellet of trivalent material, such as indium, is placed on an N-type semiconductor crystal. The pellet and crystal are heated until the pellet melts and partially fuses with the semiconductor crystal. The area where the two materials combine forms the P-type material. When the heat is removed, the material recrystallizes and a solid PN junction is formed.

The diffused junction method is the method most in use today. A mask with openings is placed on a thin section of N- or P-type semiconductor material called a wafer. The wafer is then placed in an oven and exposed to an impurity in a gaseous state. At an extremely high temperature, the impure atoms penetrate or diffuse through the exposed surfaces of the wafer. The depth of diffusion is controlled by the length of the exposure and the temperature.

FIGURE 20-8

Common diode packages.



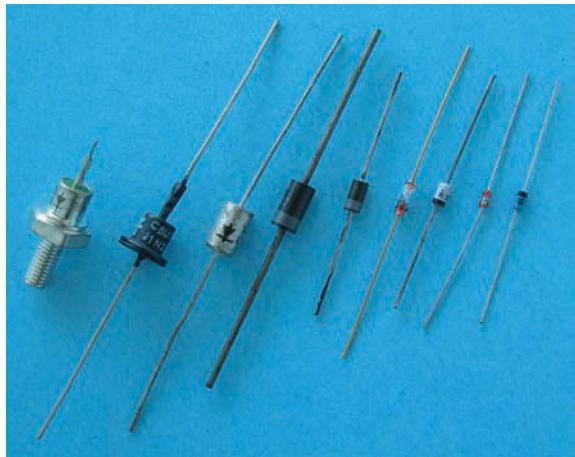
Once the PN junction is formed, the diode must be packaged to protect it from both environmental and mechanical stresses. The package must also provide a means of connecting the diode to a circuit. Package style is determined by the purpose or application of the diode (Figure 20-8). If large currents are to flow through the diode, the package must be designed to keep the junction from overheating. Figure 20-9 shows the package for diodes rated at 3 A or less. The cathode is identified by a black, white or silver band on the end.

20-4 QUESTIONS

1. Describe three methods of diode fabrication.
2. Which method of diode fabrication is favored over the others?
3. Draw four common diode packages.
4. How is the cathode identified on diode packages rated at less than 3 A?

FIGURE 20-9

Packages for diodes.



20-5 TESTING PN JUNCTION DIODES

A diode can be tested by checking the forward-to-reverse-resistance ratio with an ohmmeter. The resistance ratio indicates the ability of the diode to pass current in one direction and block current in the other direction.

A germanium diode has a low forward resistance of several hundred Ω . The reverse resistance is high, greater than 100,000 Ω . Silicon diodes have a higher forward and reverse resistance than germanium. An ohmmeter test of a diode should show a low forward resistance and a high reverse resistance.

CAUTION: SOME OHMMETERS USE HIGH-VOLTAGE BATTERIES THAT CAN DESTROY A PN JUNCTION.

The polarity of the terminals in an ohmmeter appears at the leads of the ohmmeter: Red is positive and black is negative or common. If the positive ohmmeter lead is connected to the anode of the diode and the negative lead to the cathode, the diode is forward biased. Current should then flow through the diode and the meter should indicate a low resistance. If the meter leads are reversed, the diode is reverse biased. Little current should flow and the meter should measure a high resistance.

If a diode shows both low forward and low reverse resistance, it is probably shorted. If the diode measures both high forward and high reverse resistance, then it is probably opened.

An accurate diode test can be made with most types of ohmmeters.

NOTE: SOME OHMMETERS USED FOR TROUBLESHOOTING HAVE AN OPEN-CIRCUIT LEAD VOLTAGE OF LESS THAN 0.3 V. THIS TYPE OF METER CANNOT BE USED TO MEASURE THE FORWARD RESISTANCE OF A DIODE.

The forward resistance voltage must be larger than the barrier voltage of the diode (0.7 V for silicon and 0.3 V for germanium) for conduction to take place.

An ohmmeter can also be used to determine the cathode and anode of an unmarked diode. When there is a low reading, the positive lead is connected to the anode and the negative lead is connected to the cathode.

20-5 QUESTIONS

1. How is a diode tested with an ohmmeter?
2. What precaution(s) must be taken when testing diodes with an ohmmeter?
3. How does the ohmmeter indicate that a diode is shorted?
4. How does the ohmmeter indicate that a diode is opened?
5. How can an ohmmeter be used to determine the cathode end of an unmarked diode?

SUMMARY

- A junction diode is created by joining N-type and P-type materials together.
- The region near the junction is referred to as the depletion region. Electrons cross the junction from the N-type to the P-type material and thus both the holes and the electrons near the junction are depleted.
- The size of the depletion region is limited by the charge on each side of the junction.
- The charge at the junction creates a voltage called the barrier voltage.
- The barrier voltage is 0.3 V for germanium and 0.7 V for silicon.
- A current flows through a diode only when the external voltage is greater than the barrier voltage.

- A diode that is forward biased conducts current. The P-type material is connected to the positive terminal, and the N-type material is connected to the negative terminal.
- A diode that is reverse biased conducts only a small leakage current.
- A diode is a one-directional device.
- A diode's maximum forward current and reverse voltage are specified by the manufacturer.
- The schematic symbol for a diode is:



- In a diode, the cathode is the N-type material, and the anode is the P-type material.

- Diodes can be constructed by the grown junction, alloyed junction, or diffused junction method.
- The diffused junction method is the one most often used.
- Packages for diodes of less than 3 A identify the cathode end of the diode with a black, white or silver band.
- A diode is tested by comparing the forward to the reverse resistance with an ohmmeter.
- When a diode is forward biased, the resistance is low.
- When a diode is reverse biased, the resistance is high.

CHAPTER 20 SELF-TEST

1. What does a PN junction diode accomplish?
2. Under what conditions will a silicon PN junction diode turn on?
3. Draw examples of a PN junction diode in forward and reverse bias. (Use schematic symbols.)

Zener Diodes

OBJECTIVES

After completing this chapter, the student should be able to:

- Describe the function and characteristics of a zener diode.
- Draw and label the schematic symbol for a zener diode.
- Explain how a zener diode operates as a voltage regulator.
- Describe the procedure for testing zener diodes.

Zener diodes are closely related to PN junction diodes. They are constructed to take advantage of reverse current. Zener diodes find wide application for controlling voltage in all types of circuits.



See accompanying CD for Zener Diode examples in MultiSim, Chapter 21.

21-1 ZENER DIODE CHARACTERISTICS

As previously stated, a high reverse-biased voltage applied to a diode may create a high reverse current, which can generate excessive heat and cause a diode to break down. The applied reverse voltage at which the breakdown occurs is called the *breakdown voltage*, or *peak reverse voltage*. A special diode called a **zener diode** is connected to operate in the reverse-biased mode. It is designed to operate at those voltages that exceed the breakdown voltage. This breakdown region is called the **zener region**.

When a reverse-biased voltage is applied that is high enough to cause breakdown in a zener diode, a high reverse current (I_Z) flows. The reverse current is low until breakdown occurs. After breakdown, the reverse current increases rapidly. This occurs because the resistance of the zener diode decreases as the reverse voltage increases.

The breakdown voltage of a zener diode (E_Z) is determined by the resistivity of the diode. This, in turn, is controlled by the doping technique used during manufacturing. The rated breakdown voltage represents the reverse voltage at the zener test current (I_{ZT}). The *zener test current* is somewhat less than the maximum reverse current the diode

can handle. The breakdown voltage is typically rated with 1 to 20% tolerance.

The ability of a zener diode to dissipate power decreases as the temperature increases. Therefore *power dissipation ratings* are given for specific temperatures. Power ratings are also based on lead lengths: shorter leads dissipate more power. A *derating factor* is given by the diode manufacturer to determine the power rating at different temperatures from the ones specified in their tables. For example, a derating factor of 6 mW per degree celsius means that the diode power rating decreases 6 mW for each degree of change in temperature.

Zener diodes are packaged like PN junction diodes (Figure 21-1). Low-power zener diodes are mounted in either glass or epoxy. High-power zener diodes are stud mounted with a metal case. The schematic symbol for the zener diode is similar to the PN junction diode except for the diagonal lines on the cathode bar (Figure 21-2).

FIGURE 21-1
Zener diode packages.

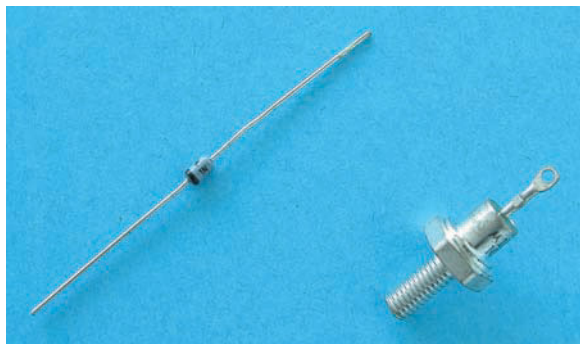


FIGURE 21-2
Schematic symbol for a zener diode.

ANODE



CATHODE

21-1 QUESTIONS

1. What is the unique feature of a zener diode?
2. How is a zener diode connected into a circuit?
3. What determines the voltage at which a zener diode breaks down?
4. What considerations go into determining the power dissipation rating of a zener diode?
5. Draw and label the schematic symbol used to represent a zener diode.

21-2 ZENER DIODE RATINGS

The *maximum zener current* (I_{ZM}) is the maximum reverse current that can flow in a zener diode without exceeding the power dissipation rating specified by the manufacturer. The reverse current (I_R) represents the leakage current before breakdown and is specified at a certain reverse voltage (E_R). The reverse voltage is approximately 80% of the zener voltage (E_Z).

Zener diodes that have a breakdown voltage of 5 V or more have a *positive zener voltage-temperature coefficient*, which means that the breakdown voltage increases as the temperature increases. Zener diodes that have a breakdown voltage of less than 4 V have a *negative zener voltage-temperature coefficient*, which means that the breakdown voltage decreases with an increase in temperature. Zener diodes with a breakdown voltage between 4 and 5 volts may have a positive or negative voltage-temperature coefficient.

A *temperature-compensated zener diode* is formed by connecting a zener diode in series with a PN junction diode, with the PN junction diode forward biased and the zener diode reverse biased.

By careful selection of the diodes, temperature coefficients can be selected that are equal and opposite. More than one PN junction diode may be needed for proper compensation.

21-2 QUESTIONS

1. What determines the maximum zener current of a zener diode?
2. What is the difference between the maximum zener current and the reverse current for a zener diode?
3. What does a positive zener voltage-temperature coefficient signify?
4. What does a negative zener voltage-temperature coefficient signify?
5. How can a zener diode be temperature compensated?

21-3 VOLTAGE REGULATION WITH ZENER DIODES

A zener diode can be used to stabilize or regulate voltage. For example, it can be used to compensate for power-line voltage changes or load-resistance changes while maintaining a constant DC output.

Figure 21-3 shows a typical zener diode regulator circuit. The zener diode is connected in se-

ries with resistor R_s . The resistor allows enough current to flow for the zener diode to operate in the zener breakdown region. The DC input voltage must be higher than the zener diode breakdown voltage. The voltage drop across the zener diode is equal to the zener diode's voltage rating. Zener diodes are manufactured to have a specific breakdown voltage rating that is often referred to as the diode's *zener voltage rating* (E_z). The voltage drop across the resistor is equal to the difference between the zener (breakdown) voltage and the input voltage.

The input voltage may increase or decrease. This causes the current through the zener diode to increase or decrease accordingly. When the zener diode is operating in the zener voltage, or breakdown region, a large current will flow through the zener with an increase in input voltage. However, the zener voltage remains the same. The zener diode opposes an increase in input voltage, because when the current increases the resistance drops. This allows the zener diode's output voltage to remain constant as the input voltage changes. The change in the input voltage appears across the series resistor. The resistor is in series with the zener diode, and the sum of the voltage drop must equal the input voltage. The output voltage is taken across the zener diode. The output voltage can be increased or decreased by changing the zener diode and the series resistor.

The circuit just described supplies a constant voltage. When a circuit is designed, the current in the circuit must be considered as well as the voltage. The external load requires a specific load current (I_L) determined by the load resistance and output voltage (Figure 21-4). The load current and the zener current flow through the series resistor. The series resistor must be chosen so that the zener current is adequate to keep the zener diode in the breakdown zone and allow the current to flow.

When the load resistance increases, the load current decreases, which should increase the voltage across the load resistance. But the zener diode

FIGURE 21-3

Typical zener diode regulator circuit.

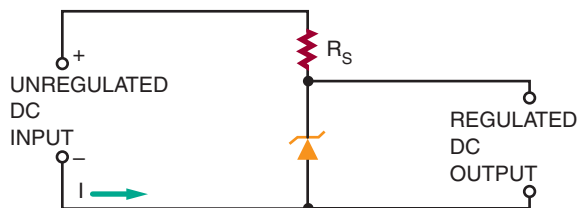
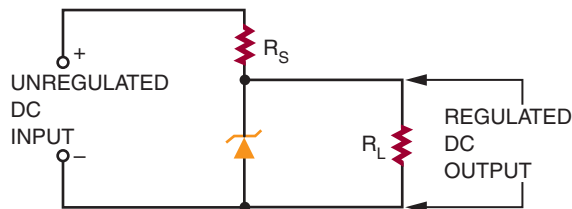


FIGURE 21-4

Zener diode voltage regulator with load.



opposes any change by conducting more current. The sum of the zener current and the load current through the series resistor remains constant. This action maintains the same voltage across the series resistor.

Similarly, when the load current increases, the zener current decreases, maintaining a constant voltage. This action allows the circuit to regulate for change in output current as well as input voltage.

21-3 QUESTIONS

1. What is a practical function for a zener diode?
2. Draw a schematic diagram of a zener diode regulator circuit.
3. How can the voltage of a zener diode voltage regulator circuit be changed?
4. What must be considered in designing a zener diode voltage regulator?

5. Describe how a zener diode voltage regulator maintains a constant output voltage.

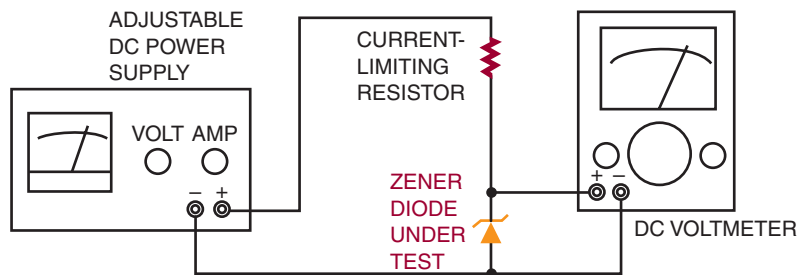
21-4 TESTING ZENER DIODES

Zener diodes can be quickly tested for opens, shorts, or leakage with an ohmmeter. The ohmmeter is connected in forward and reverse bias in the same manner as with PN junction diodes. However, these tests do not provide information on whether the zener diode is regulating at the rated value. For that information, a regulation test must be performed with a metered power supply that can indicate both voltage and current.

Figure 21-5 shows the proper setup for a zener diode regulation test. The output of the power supply is connected with a limiting resistor in series with a zener diode to be tested. A voltmeter is connected across the zener diode under test to monitor the zener voltage. The output voltage is slowly increased until the specified current is flowing through the zener diode. The current is then varied on either side of the specified zener current (I_Z). If the voltage remains constant, the zener diode is operating properly.

FIGURE 21-5


Setup for testing zener diode regulation.



21-4 QUESTIONS

1. Describe the process for testing a zener diode with an ohmmeter.
2. What parameters are not tested when using an ohmmeter to test a zener diode?
3. Draw a schematic diagram showing how to connect a zener diode to check its breakdown voltage.
4. Describe how the circuit in question 3 operates to determine whether the zener diode is operating properly.
5. How can the cathode end of a zener diode be determined using an ohmmeter?

SUMMARY

- Zener diodes are designed to operate at voltages greater than the breakdown voltage (peak reverse voltage).
- The breakdown voltage of a zener diode is determined by the resistivity of the diode.
- Zener diodes are manufactured with a specific breakdown (zener) voltage.
- Power dissipation of a zener diode is based on temperature and lead lengths.
- The schematic symbol for a zener diode is:

- Zener diodes are packaged the same as PN junction diodes.
- Zener diodes with a breakdown voltage greater than 5 V have a positive zener voltage-temperature coefficient.
- Zener diodes with a breakdown voltage less than 4 V have a negative zener voltage-temperature coefficient.
- Zener diodes are used to stabilize or regulate voltage.
- Zener diode regulators provide a constant output voltage despite changes in the input voltage or output current.
- Zener diodes can be tested for opens, shorts, or leakage with an ohmmeter.
- To determine whether a zener diode is regulating at the proper voltage, a regulation test must be performed.

CHAPTER 21 SELF-TEST

1. Explain how a zener diode functions in a voltage regulator circuit.
2. Describe the process for testing a zener diode's voltage rating.

Bipolar Transistors

OBJECTIVES

After completing this chapter, the student should be able to:

- Describe how a transistor is constructed and its two different configurations.
- Draw and label the schematic symbol for an NPN and a PNP transistor.
- Identify the ways of classifying transistors.
- Identify the function of a transistor using a reference manual and the identification number (2NXXXX).
- Identify commonly used transistor packages.
- Describe how to bias a transistor for operation.
- Explain how to test a transistor with both a transistor tester and an ohmmeter.
- Describe the process used for substituting a transistor.

In 1948, Bell Laboratories developed the first working junction transistor. A transistor is a three-element, two-junction device used to control electron flow. By varying the amount of voltage applied to the three elements, the amount of current can be controlled for purposes of amplification, oscillation, and switching. These applications are covered in Chapters 28, 29, and 30.

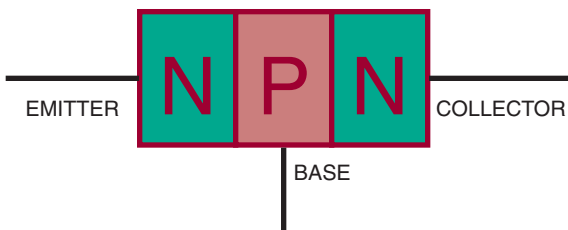
22-1

TRANSISTOR CONSTRUCTION

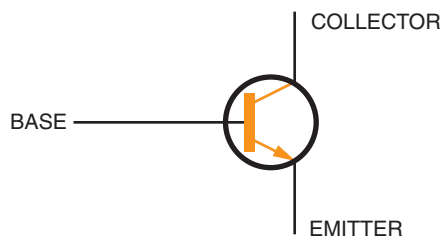
When a third layer is added to a semiconductor diode, a device is produced that can amplify power, current, or voltage. The device is called a **bipolar transistor**, also referred to as a **junction transistor** or **transistor**. The term *transistor* will be used here.

FIGURE 22-1

NPN transistor.



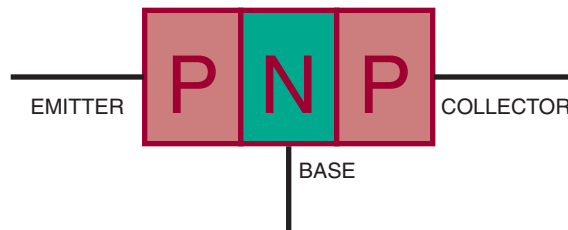
(A) BLOCK DIAGRAM OF AN NPN TRANSISTOR



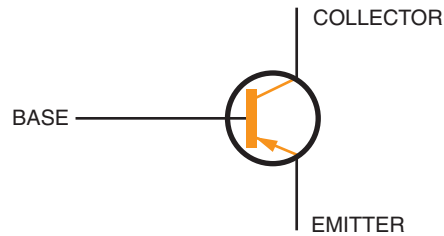
(B) SCHEMATIC SYMBOL FOR A NPN TRANSISTOR

FIGURE 22-2

PNP transistor.



(A) BLOCK DIAGRAM OF A PNP TRANSISTOR



(B) SCHEMATIC SYMBOL FOR A PNP TRANSISTOR

A transistor, like a junction diode, can be constructed of germanium or silicon, but silicon is more popular. A transistor consists of three alternately doped regions (as compared to two in a diode). The three regions are arranged in one of two ways.

In the first method, the P-type material is sandwiched between two N-type materials, forming an NPN transistor (Figure 22-1). In the second method, a layer of N-type material is sandwiched between two layers of P-type material, forming a PNP transistor (Figure 22-2).

In both types of transistor, the middle region is called the *base* and the outer regions are called the *emitter* and *collector*. The emitter, base, and collector are identified by the letters *E*, *B*, and *C*, respectively.

22-1 QUESTIONS

1. How does the construction of a transistor differ from the construction of a PN junction diode?
2. What are the two types of transistors?
3. What are the three parts of a transistor called?
4. Draw and label the schematic symbols for an NPN and a PNP transistor.
5. What are transistors used for?

22-2 TRANSISTOR TYPES AND PACKAGING

Transistors are classified by the following methods:

1. According to type (either NPN or PNP)
2. According to the material used (germanium or silicon)
3. According to major use (high or low power, switching, or high frequency)

Most transistors are identified by a number. This number begins with a 2 and the letter *N* and has up to four more digits. These symbols identify the device as a transistor and indicate that it has two junctions.

A package serves as protection for the transistor and provides a means of making electrical connections to the emitter, base, and collector regions. The package also serves as a heat sink, or an area from which heat can be extracted, removing excess heat from the transistor and preventing heat damage. Many different packages are available, covering a wide range of applications (Figure 22-3).

Transistor packages are designated by size and configuration. The most common package identifier consists of the letters *TO* (transistor outline) followed by a number. Some common transistor packages are shown in Figure 22-4.

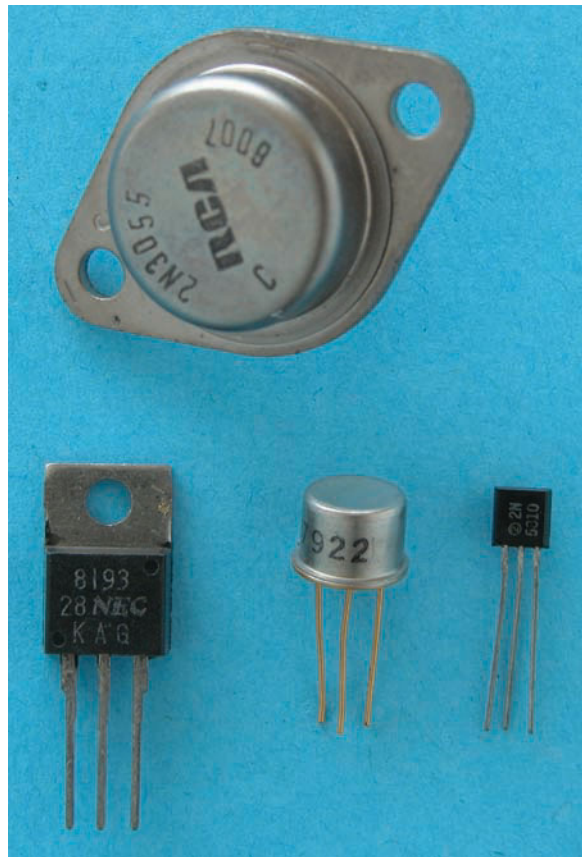
Because of the large assortment of transistor packages available, it is difficult to develop rules for identifying the emitter, base, and collector leads of each device. It is best to refer to the manufacturer's specification sheet to identify the leads of each device.

22-2 QUESTIONS

1. How are transistors classified?
2. What symbols are used to identify transistors?
3. What purposes does the packaging of a transistor serve?
4. How are transistor packages labeled?

FIGURE 22-3

Various transistor packages.

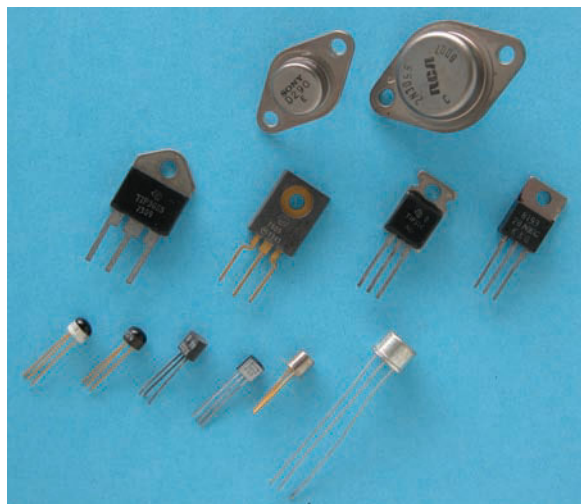


5. What is the best method for determining which leads of a transistor are the base, emitter, and collector?

22-3 BASIC TRANSISTOR OPERATION

A diode is a rectifier and a transistor is an amplifier. A transistor may be used in a variety of ways, but its basic functions are to provide current amplification of a signal or to switch the signal.

FIGURE 22-4
Typical transistor packages.

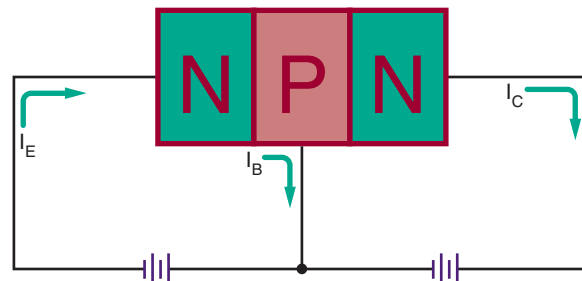


A transistor must be properly biased by external voltages so that the emitter, base, and collector regions interact in the desired manner. In a properly biased transistor, the emitter junction is forward biased and the collector junction is reverse biased. A properly biased NPN transistor is shown in Figure 22-5.

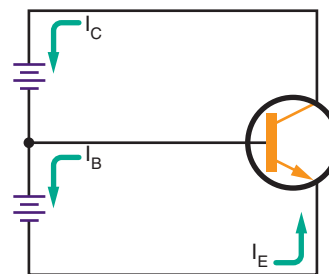
Electrons are caused to flow from an NPN transistor emitter by a forward bias. Forward bias is a positive voltage on the base terminal with respect to the emitter terminal. A positive potential attracts electrons, creating an electron flow from the emitter. The electrons that are attracted into the base are now influenced by the positive potential applied to the collector. The majority of electrons are attracted to the collector and into the positive side of the reverse-biased voltage source. A few electrons are absorbed into the base region and support a small electron flow from it. For this action to occur, the base region must be extremely thin. In a properly biased PNP transistor, the batteries must be reversed (Figure 22-6).

The difference between the NPN and PNP transistors is twofold: The batteries have oppo-

FIGURE 22-5
Properly biased NPN transistor.



(A) BLOCK DIAGRAM OF A BIASED NPN TRANSISTOR



(B) SCHEMATIC DIAGRAM OF A BIASED NPN TRANSISTOR

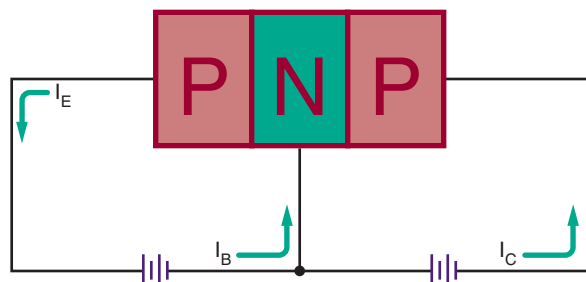
site polarities, and the direction of the electron flow is reversed.

As with the diode, a barrier voltage exists within the transistor. In a transistor, the barrier voltage is produced across the emitter-base junction. This voltage must be exceeded before electrons can flow through the junction. The internal barrier voltage is determined by the type of semiconductor material used. As in diodes, the internal barrier voltage is 0.3 V for germanium transistors and 0.7 V for silicon transistors.

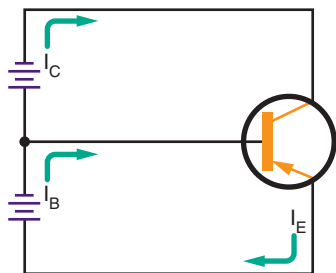
The collector-base junction of a transistor must also be subjected to a positive potential that is high enough to attract most of the electrons supplied by the emitter. The reverse-bias voltage applied to the collector-base junction is usually much higher than the forward-bias voltage across the emitter-base junction, supplying this higher voltage.

FIGURE 22-6

Properly biased PNP transistor.



(A) BLOCK DIAGRAM OF A BIASED PNP TRANSISTOR



(B) SCHEMATIC DIAGRAM OF A BIASED PNP TRANSISTOR

22-3 QUESTIONS

1. What are the basic functions of a transistor?
2. What is the proper method for biasing a transistor?
3. What is the difference between biasing an NPN and a PNP transistor?
4. What is the barrier voltage for a germanium and a silicon transistor?
5. What is the difference between the collector-base junction and the emitter-base junction bias voltages?

22-4 TRANSISTOR TESTING

Transistors are semiconductor devices that usually operate for long periods of time without failure. If a transistor does fail, the failure is generally caused by excessively high temperature, current, or voltage. Failure can also be caused by extreme mechanical stress. As a result of this electrical or mechanical abuse, a transistor may open or short internally, or its characteristics may alter enough to affect its operation. There are two methods for checking a transistor to determine if it is functioning properly: with an ohmmeter and with a transistor tester.

A conventional ohmmeter can help detect a defective transistor in an out-of-circuit test. Resistance tests are made between the two junctions of a transistor in the following way: emitter to base, collector to base, and collector to emitter. In testing the transistor, the resistance is measured between any two terminals with the meter leads connected one way. The meter leads are then reversed. In one meter connection, the resistance should be high, 10,000 ohms or more. In the other meter connection, the resistance should be lower, less than 10,000 ohms.

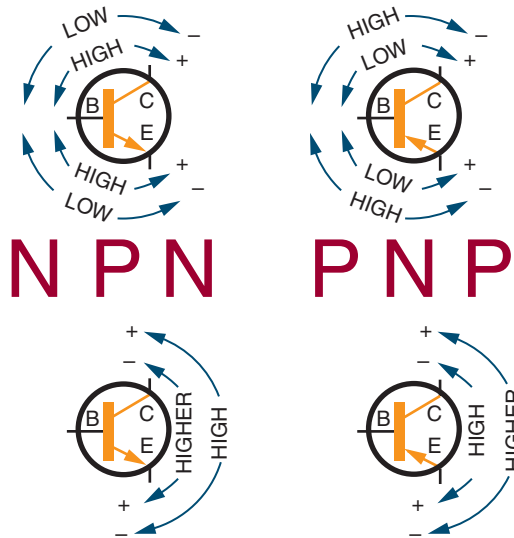
Each junction of a transistor exhibits a low resistance when it is forward biased and a high resistance when reverse biased. The battery in the ohmmeter is the source of the forward- and reverse-bias voltage. The exact resistance measured varies with different types of transistors, but there is always a change when the ohmmeter leads are reversed. This method of checking works for either NPN or PNP transistors (Figure 22-7).

If a transistor fails this test, it is defective. If it passes, it may still be defective. A more reliable means of testing a transistor is by using a transistor tester.

Transistor testers are designed specifically for testing transistors and diodes. There are two types:

FIGURE 22-7

Resistance measurements of transistor junctions.



CAUTION: AS WITH DIODES, THE OHMMETER TERMINAL VOLTAGE MUST NEVER EXCEED THE MAXIMUM VOLTAGE RATING BETWEEN THE JUNCTIONS OF A TRANSISTOR. THE LOWER SCALES OF SOME OHMMETERS CAN SUPPLY A DAMAGING CURRENT TO THE TRANSISTOR UNDER TEST. AS A PRECAUTIONARY MEASURE, IT IS BEST TO START OUT AT THE SAFEST RANGE AND THEN CHANGE TO A SCALE THAT GIVES AN ADEQUATE READING.

an in-circuit tester and an out-of-circuit tester. Both may be housed in the same package (Figure 22-8).

The transistor's ability to amplify is taken as a rough measure of its performance. There is an advantage with an in-circuit tester because the transistor does not have to be removed from the circuit. An out-of-circuit transistor tester can not only determine whether the transistor is good or defective, but also determine the leakage current. Leakage tests cannot be made in-circuit.

FIGURE 22-8

Transistor tester.



Transistor testers contain controls for adjusting voltage, current, and signal. Refer to the manufacturer's instruction manual for the proper settings.

22-4 QUESTIONS

1. What may cause a transistor to fail?
2. What are two methods of testing a transistor?
3. When using an ohmmeter, what should the results be for an NPN transistor?
4. What are the two types of commercial transistor testers?

22-5 TRANSISTOR SUBSTITUTION

Numerous guides have been prepared by manufacturers to provide cross references for transistor substitution. Most substitutions can be made with confidence.

If the transistor is unlisted or the number of the transistor is missing, the following procedure can be used to make an accurate replacement selection.

1. NPN or PNP? The first source of information is the symbol on the schematic diagram. If a schematic is not available, the polarity of the voltage source between the emitter and collector must be determined. If the collector voltage is positive with respect to the emitter voltage, then it is an NPN device. If the collector voltage is negative with respect to the emitter voltage, then it is a PNP device. An easy way to remember the polarity of the collector voltage for each type of transistor is shown in Figure 22–9.
2. Germanium or silicon? Measure the voltage from the emitter to the base. If the voltage is approximately 0.3 V, the transistor is germanium. If the voltage is approximately 0.7 V, the transistor is silicon.
3. Operating frequency range? Identify the type of circuit and determine whether it is working in the audio range, the kilohertz range, or the megahertz range.
4. Operating voltage? Voltages from collector to emitter, collector to base, and emitter to base should be noted either from the schematic diagram or by actual voltage measurement. The transistor selected for replacement should have voltage ratings that are at least three to four times the actual operating voltage. This helps to protect against voltage

spikes, transients, and surges that are inherent in most circuits.

5. Collector current requirements? The easiest way to determine the actual current is to measure the current in the collector circuit with an ammeter. This measurement should be taken under maximum power conditions. Again, a safety factor of three to four times the measured current should be allowed.
6. Maximum power dissipation? Use maximum voltage and collector current requirements to determine maximum power requirements ($P = IE$). The transistor is a major factor in determining power dissipation in the following types of circuits:
 - Input stages, AF, or RF (50 to 200 mW)
 - IF stages and driver stages (200 mW to 1 W)
 - High-power output stages (1 W and higher)
7. Current gain? The common emitter small signal DC current gain referred to as h_{fe} or Beta (β) should be considered. Some typical gain categories are:
 - RF mixers, IF and AF (80 to 150)
 - RF and AF drivers (25 to 80)
 - RF and AF output (4 to 40)
 - High-gain preamps and sync separators (150 to 500)
8. Case style? Frequently, there is no difference between the case styles of original parts and recommended replacements. Case types and sizes need only be considered where an exact mechanical fit is required. Silicon grease should always be used with power devices to promote heat transfer.
9. Lead configuration? This is not a prime consideration for replacement transistors, although it may be desirable for ease of insertion and appearance.

FIGURE 22–9 How to remember the polarity of the collector voltage.

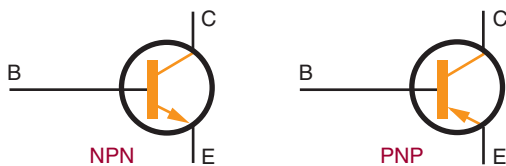


22-5 QUESTIONS

1. Where can suggestions for transistor replacements be found?
2. Why does it matter whether a transistor is germanium or silicon?
3. Why are the operating frequency, voltage, current, and power ratings important when replacing a transistor?
4. What does the transistor's Beta refer to?
5. Are the transistor's case and lead configuration important when substituting a transistor?

SUMMARY

- A transistor is a three-layer device used to amplify and switch power and voltage.
- A bipolar transistor is also called a junction transistor or simply a transistor.
- Transistors can be configured as NPN or PNP.
- The middle region of the transistor is called the base, and the two outer regions are called the emitter and collector.
- The schematic symbols used for NPN and PNP transistors are:



- A transistor is classified according to whether it is NPN or PNP, silicon or germanium, high or low power, and switching or high frequency.
- Transistors are identified with a prefix of 2N followed by up to four digits.
- The transistor package provides protection, a heat sink, and a support for the leads.
- Transistor packages are identified with the letters *TO* (transistor outline).
- In a properly biased transistor, the emitter-base junction is forward biased and the collector-base junction is reverse biased.
- PNP transistor bias sources are the reverse of NPN bias sources.
- The internal barrier voltage for germanium transistors is 0.3 V and for silicon transistors is 0.7 V.
- The reverse-bias voltage applied to the collector-base junction is higher than the forward-bias voltage applied to the emitter-base junction.
- When a transistor is tested with an ohmmeter, each junction exhibits a low resistance when it is forward biased and a high resistance when it is reverse biased.
- Transistor testers are available for testing transistors in and out of circuit.

CHAPTER 22 SELF-TEST

1. The junction of a transistor can be forward biased, reverse biased, or unbiased. What are the normal conditions of bias across the emitter-base and collector-base junctions of a transistor?
2. When checking a good transistor with an ohmmeter, what kind of resistance should exist across each junction?

3. Using an ohmmeter, what difficulty, if any, would be experienced in identifying the transistor material type and emitter, base, and collector leads of an unknown transistor?
4. When connecting a transistor in a circuit, why must the technician know whether a transistor is NPN or PNP?
5. How does the testing of a transistor with an ohmmeter compare to testing a transistor with a transistor tester?

Field Effect Transistors (FETs)

OBJECTIVES

After completing this chapter, the student should be able to:

- Describe the difference between transistors, JFETs, and MOSFETs.
- Draw schematic symbols for both P-channel and N-channel JFETs, depletion MOSFETs, and enhancement MOSFETs.
- Describe how a JFET, depletion MOSFET, and enhancement MOSFET operate.
- Identify the parts of JFETs and MOSFETs.
- Describe the safety precautions that must be observed when handling MOSFETs.
- Describe the procedure for testing JFETs and MOSFETs with an ohmmeter.

The history of field effect transistors (FETs) dates back to 1925, when Julius Lillienfeld invented both the junction FET and the insulated gate FET. Both of these devices currently dominate electronics technology. This chapter is an introduction to the theory of junction and insulated gate FETs.

23-1 JUNCTION FETs

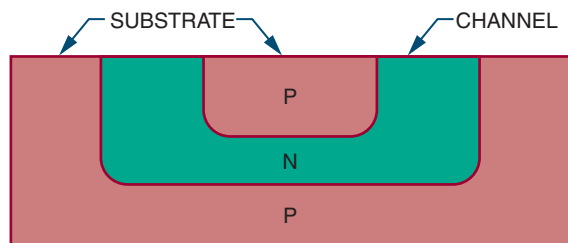
The **junction field effect transistor (JFET)** is a unipolar transistor that functions using only majority carriers. The JFET is a voltage-operated device. JFETs are constructed from N-type and P-type semiconductor materials and are capable of amplifying electronic signals, but they are con-

structed differently from bipolar transistors and operate on different principles. Knowing how a JFET is constructed helps to understand how it operates.

Construction of a JFET begins with a substrate, or base, of lightly doped semiconductor material. The **substrate** can be either P- or N-type material. The PN junction in the substrate is made

FIGURE 23-1

Cross section of an N-channel JFET.



using both the diffusion and growth methods (see Chapter 20). The shape of the PN junction is important. Figure 23-1 shows a cross section of the embedded region within the substrate. The U-shaped region is called the **channel** and is flush with the upper surface of the substrate. When the channel is made of N-type material in a P-type substrate, an *N-channel JFET* is formed. When the channel is made of P-type material in an N-type substrate, a *P-channel JFET* is formed.

Three electrical connections are made to a JFET (Figure 23-2). One lead is connected to the substrate to form the *gate* (G). One lead is connected to each end of the channel to form the *source* (S) and the *drain* (D). It does not matter which lead is attached to the source or drain, because the channel is symmetrical.

FIGURE 23-2

Lead connections for an N-channel JFET.

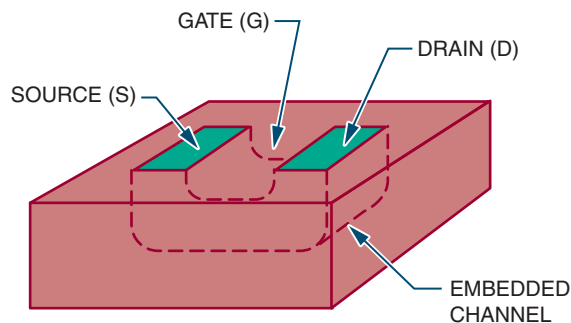
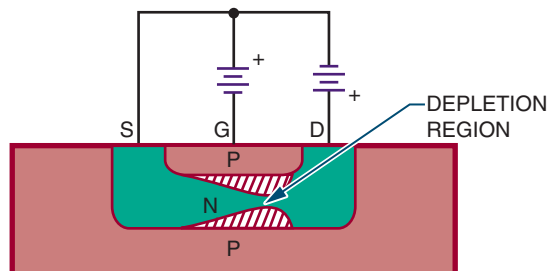


FIGURE 23-3

Properly biased N-channel JFET.



The operation of a JFET requires two external bias voltages. One of the voltage sources (E_{DS}) is connected between the source and the drain, forcing the current to flow through the channel. The other voltage source (E_{GS}) is connected between the gate and the source. It controls the amount of current flowing through the channel. Figure 23-3 shows a properly biased N-channel JFET.

Voltage source E_{DS} is connected so that the source is made negative with respect to the drain. This causes a current to flow, because the majority carriers are electrons in the N-type material. The source-to-drain current is called the FET's *drain current* (I_D). The channel serves as resistance to the supply voltage (E_{DS}).

The gate-to-source voltage (E_{GS}) is connected so that the gate is negative with respect to the source. This causes the PN junction formed by the gate and channel to be reverse biased. This creates a depletion region in the vicinity of the PN junction, which spreads inward along the length of the channel. The depletion region is wider at the drain end because the E_{DS} voltage adds to the E_{GS} voltage, creating a higher reverse bias voltage than that appearing across the source end.

The size of the depletion region is controlled by E_{GS} . As E_{GS} increases, so does the depletion region. A decrease in E_{GS} causes a decrease in the depletion region. When the depletion region increases, it effectively reduces the size of the

channel. This reduces the amount of current that is able to flow through it. E_{GS} can thus be used to control the drain current (I_D) that flows through the channel. An increase in E_{GS} causes a decrease in I_D .

In normal operation, the input voltage is applied between the gate and the source. The resulting output current is the drain current (I_D). In a JFET, the input voltage is used to control the output current. In a transistor, it is the input current, not the voltage, that is used to control the output current.

Because the gate-to-source voltage is reverse biased, the JFET has an extremely high input resistance. If the gate-to-source voltage were forward biased, a large current would flow through the channel, causing the input resistance to drop and reducing the gain of the device. The amount of gate-to-source voltage required to reduce I_D to zero is called the *gate-to-source cut-off voltage* ($E_{GS(off)}$). This value is specified by the manufacturer of the device.

The drain-to-source voltage (E_{DS}) has control over the depletion region within the JFET. As E_{DS} increases, I_D also increases. A point is then reached where I_D levels off, increasing only slightly as E_{DS} continues to rise. This occurs because the size of the depletion region has increased also, to the point where the channel is depleted of minority carriers and cannot allow I_D to increase proportionally with E_{DS} . The resistance of the channel also increases with an increase of E_{DS} , with the result that I_D increases at a slower rate. However, I_D levels off because the depletion region expands and reduces the channel's width. When this occurs, I_D is said to *pinch off*. The value of E_{DS} required to pinch off or limit I_D is called the *pinch-off voltage* (E_p). E_p is usually given by the manufacturer for an E_{GS} of zero. E_p is always close to $E_{GS(off)}$ when E_{GS} is equal to zero. When E_p is equal to E_{GS} the drain current is pinched off.

P-channel and N-channel JFETs have the same characteristics. The main difference be-

tween them is the direction of the drain current (I_D) through the channel. In a P-channel JFET, the polarity of the bias voltages (E_{GS} , E_{DS}) is opposite to that in an N-channel JFET.

The schematic symbols used for N-channel and P-channel JFETs are shown in Figure 23-4. The polarities required to bias an N-channel JFET are shown in Figure 23-5 and for a P-channel JFET in Figure 23-6.

FIGURE 23-4

Schematic symbols for JFETs.

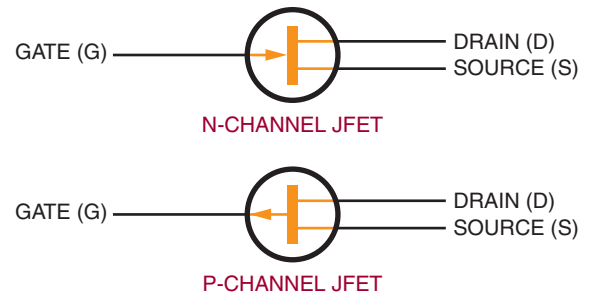


FIGURE 23-5

The polarities required to bias an N-channel JFET.

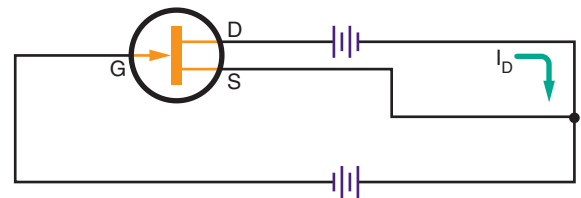
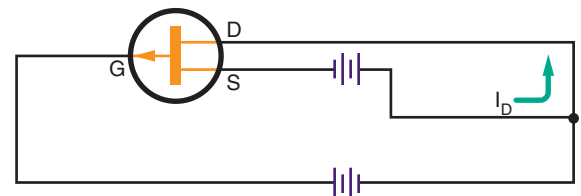


FIGURE 23-6

The polarities required to bias a P-channel JFET.



23-1 QUESTIONS

1. Describe how a JFET differs in construction from a bipolar transistor.
2. Identify the three electrical connections to the JFET.
3. How is the current shut off in a JFET?
4. Define the following with reference to JFETs:
 - a. Depletion region
 - b. Pinch-off voltage
 - c. Source
 - d. Drain
5. Draw and label a schematic diagram of a P-channel and an N-channel JFET.

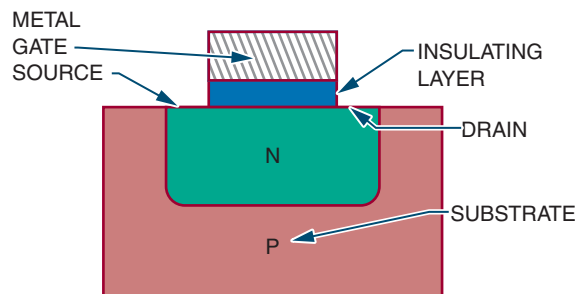
23-2 DEPLETION INSULATED GATE FETs (MOSFETs)

Insulated gate FETs do not use a PN junction. Instead they use a metal gate, which is electrically isolated from the semiconductor channel by a thin layer of oxide. This device is known as a *metal oxide semiconductor field effect transistor* (**MOSFET** or MOST).

There are two important types of MOSFETs: N-type units with N channels and P-type units with P channels. N-type units with N channels are called **depletion mode** devices because they conduct when zero bias is applied to the gate. In the depletion mode, the electrons are conducting until they are depleted by the gate bias voltage. The drain current is depleted as a negative bias is applied to the gate. P-type units with P channels are **enhancement mode** devices. In the enhancement mode, the electron flow is normally cut off until it is aided or enhanced by the bias voltage on the gate. Although P-channel depletion MOSFETs

FIGURE 23-7

N-channel depletion MOSFET.

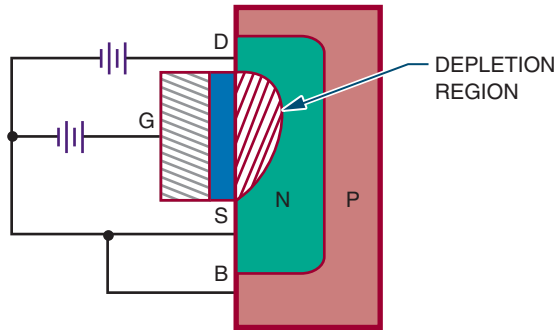


and N-channel enhancement MOSFETs exist, they are not commonly used.

Figure 23-7 shows a cross section of an N-channel **depletion MOSFET**. It is formed by implanting an N channel in a P substrate. A thin insulating layer of silicon dioxide is then deposited on the channel, leaving the ends of the channel exposed to be attached to wires and act as the source and the drain. A thin metallic layer is attached to the insulating layer over the N channel. The metallic layer serves as the gate. An additional lead is attached to the substrate. The metal gate is insulated from the semiconductor channel so that the gate and the channel do not form a PN junction. The metal gate is used to control the conductivity of the channel as in the JFET.

The MOSFET shown in Figure 23-8 has an N channel. The drain is always made positive with respect to the source, as in the JFET. The majority carriers are electrons in the N channel, which allow drain current (I_D) to flow from the source to the drain. The drain current is controlled by the gate-to-source bias voltage (E_{GS}), as in the JFET. When the source voltage is zero, a substantial drain current flows through the device, because a large number of majority carriers (electrons) are present in the channel. When the gate is made negative with respect to the source, the drain current decreases as the majority carriers are depleted. If the negative gate voltage is increased

FIGURE 23–8
N-channel depletion MOSFET with bias supply.



sufficiently, the drain current drops to zero. One difference between MOSFETs and JFETs is that the gate of the N-channel depletion MOSFET can also be made positive with respect to the source. This cannot be done with a JFET because it would cause the gate and channel PN junction to be forward biased.

When the gate voltage of a depletion MOSFET is made positive, the silicon dioxide insulating layer prevents any current from flowing through the gate lead. The input resistance remains high, and more majority carriers (electrons) are drawn into the channel, enhancing the conductivity of the channel. A positive gate voltage can be used to increase the MOSFET's drain current, and a negative gate voltage can be used to decrease the drain current. Because a negative gate voltage is required to deplete the N-channel MOSFET, it is called a depletion mode device. A large amount of drain current flows when the gate voltage is equal to zero. All depletion mode devices are considered to be normally turned on when the gate voltage is equal to zero.

An N-channel depletion MOSFET is represented by the schematic symbol shown in Figure 23–9. Note that the gate lead is separated from the source and drain leads. The arrow on the substrate lead points inward to represent an N-channel

FIGURE 23–9
Schematic symbol for an N-channel depletion MOSFET.

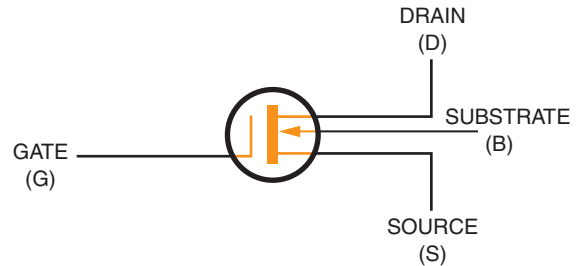
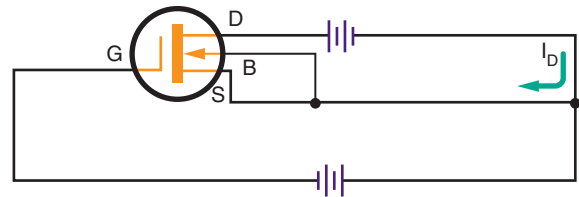


FIGURE 23–10
Properly biased N-channel depletion MOSFET.



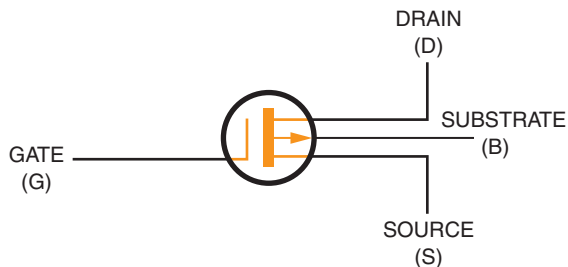
device. Some MOSFETs are constructed with the substrate connected internally to the source lead and the separate substrate lead is not used.

A properly biased N-channel depletion MOSFET is shown in Figure 23–10. Note that it is biased the same way as an N-channel JFET. The drain-to-source voltage (E_{DS}) must always be applied so that the drain is positive with respect to the source. The gate-to-source voltage (E_{GS}) can be applied with the polarity reversed. The substrate is usually connected to the source, either internally or externally. In special applications, the substrate may be connected to the gate or another point within the FET circuit.

A depletion MOSFET may also be constructed as a P-channel device. P-channel devices operate in the same manner as N-channel devices. The difference is that the majority carriers are holes. The drain lead is made negative with respect to the source, and the drain current flows in the opposite

FIGURE 23-11

Schematic symbol for a P-channel depletion MOSFET.



direction. The gate may be positive or negative with respect to the source.

The schematic symbol for a P-channel depletion MOSFET is shown in Figure 23-11. The only difference between the N-channel and P-channel symbols is the direction of the arrow on the substrate lead.

Both N-channel and P-channel depletion MOSFETs are symmetrical. The source and drain leads may be interchanged. In special applications, the gate may be offset from the drain region to reduce capacitance between the gate and drain. When the gate is offset, the source and drain leads cannot be interchanged.

23-2 QUESTIONS

1. How does a MOSFET differ in construction from a JFET?
2. Describe how a MOSFET conducts a current.
3. What is the major difference in operation between a MOSFET and a JFET?
4. Draw and label a schematic diagram of a P-channel and an N-channel MOSFET.
5. What leads can be interchanged on JFETs and MOSFETs?

23-3

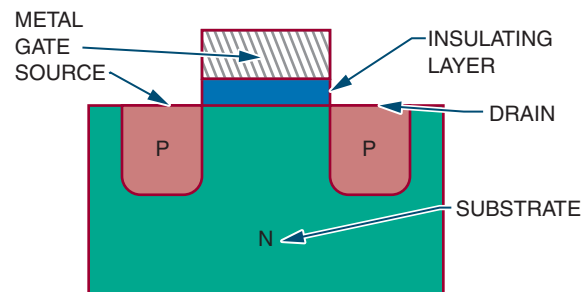
ENHANCEMENT INSULATED GATE FETs (MOSFETs)

Depletion MOSFETs are devices that are normally on. That is, they conduct a substantial amount of drain current when the gate-to-source voltage is zero. This is useful in many applications. It is also useful to have a device that is normally off—that is, a device that conducts only when a suitable value of E_{GS} is applied. Figure 23-12 shows a MOSFET that functions as a normally off device. It is similar to a depletion MOSFET, but it does not have a conducting channel. Instead, the source and drain regions are diffused separately into the substrate. The figure shows an N-type substrate and P-type source and drain regions. The opposite arrangement could also be used. The lead arrangements are the same as with a depletion MOSFET.

A P-channel enhancement MOSFET must be biased so that the drain is negative with respect to the source. When only the drain-to-source voltage (E_{DS}) is applied, a drain current does not flow. This is because there is no conducting channel between the source and drain. When the gate is made negative with respect to the source, holes are drawn toward the gate, where they gather to create a P-type channel that allows current to

FIGURE 23-12

P-channel enhancement MOSFET.



flow from the drain to the source. When the negative gate voltage is increased, the size of the channel increases, allowing even more current to flow. An increase in gate voltage tends to enhance the drain current.

The gate of a P-channel enhancement MOSFET can be made positive with respect to the source without affecting the operation. The MOSFET's drain current is zero and cannot be reduced with the application of a positive gate voltage.

The schematic symbol for a P-channel enhancement MOSFET is shown in Figure 23–13. It is the same as that for a P-channel depletion MOSFET except that a broken line is used to interconnect the source, drain, and substrate region. This indicates the normally off condition. The arrow points outward to indicate a P channel.

A properly biased P-channel enhancement MOSFET is shown in Figure 23–14. Notice that E_{DS} makes the MOSFET's drain negative with re-

spect to the source. E_{GS} also makes the gate negative with respect to the source. Only when E_{GS} increases from zero volts and applies a negative voltage to the gate does a substantial amount of drain current flow. The substrate is normally connected to the source, but in special applications the substrate and source may be at different potentials.

N-channel enhancement MOSFETs may also be constructed. These devices operate with a positive gate voltage so that electrons are attracted toward the gate to form an N-type channel. Otherwise, these devices function like P-channel devices.

Figure 23–15 shows the schematic symbol for an N-channel enhancement MOSFET. It is similar to the P-channel device except that the arrow points inward to identify the N channel. Figure 23–16 shows a properly biased N-channel enhancement MOSFET.

FIGURE 23–13
Schematic symbol for a P-channel enhancement MOSFET.

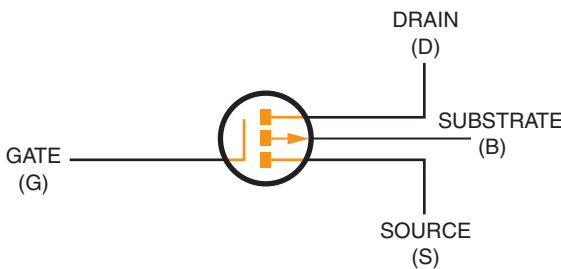


FIGURE 23–14
Properly biased P-channel enhancement MOSFET.

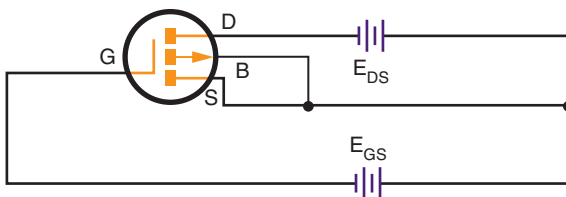


FIGURE 23–15
Schematic symbol for an N-channel enhancement MOSFET.

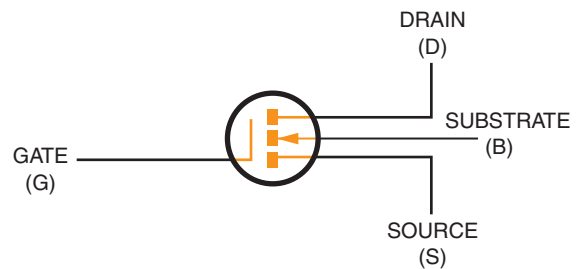
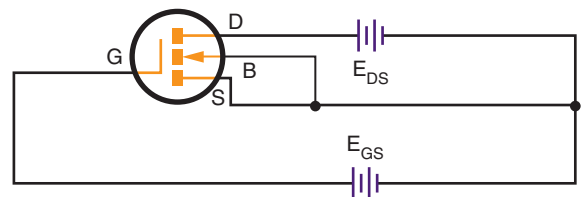


FIGURE 23–16
Properly biased N-channel enhancement MOSFET.



MOSFETs are usually symmetrical, like JFETs. Therefore the source and drain can usually be reversed or interchanged.

23-3 QUESTIONS

1. How do depletion and enhancement MOSFETs differ from each other?
2. Describe how an enhancement insulated gate FET operates.
3. Draw and label the schematic symbol for a P-channel and an N-channel enhancement MOSFET.
4. Why are there four leads on a MOSFET?
5. What leads on an enhancement MOSFET can be reversed?

23-4 MOSFET SAFETY PRECAUTIONS

Certain safety precautions must be observed when handling and using MOSFETs. It is important to check the manufacturer's specification sheet for maximum rating of E_{GS} .

CAUTION: IF E_{GS} IS INCREASED TOO MUCH, THE THIN INSULATING LAYER RUPTURES, RUINING THE DEVICE. THE INSULATING LAYER IS SO SENSITIVE THAT IT CAN BE DAMAGED BY A STATIC CHARGE THAT HAS BUILT UP ON THE LEADS OF THE DEVICE. ELECTROSTATIC CHARGES ON FINGERS CAN BE TRANSFERRED TO THE MOSFET'S LEADS WHEN HANDLING OR MOUNTING THE DEVICE.

To avoid damage to the device, MOSFETs are usually shipped with the leads shorted together. Shorting techniques include wrapping leads with a shorting wire, inserting the device into a shorting ring, pressing the device into conductive foam, taping several devices together, shipping in antistatic tubes, and wrapping the device in metal foil.

Newer MOSFETs are protected with zener diodes electrically connected between the gate and source internally. The diodes protect against static discharges and in-circuit transients and eliminate the need for external shorting devices. In electronics, a *transient* is a temporary component of current existing in a circuit during adjustment to a load change, voltage source difference, or line impulse.

If the following procedures are followed, unprotected MOSFETs can be handled safely:

1. Prior to installation into a circuit, the leads should be kept shorted together.
2. The hand used to handle the device should be grounded with a metallic wrist band.
3. The soldering iron tip should be grounded.
4. A MOSFET should never be inserted or removed from its circuit when the power is on.

23-4 QUESTIONS

1. What is the reason that MOSFETs have to be handled very carefully?
2. What voltage source, if exceeded, can ruin a MOSFET?
3. What methods are used to protect MOSFETs during shipping?
4. What precautions have been taken to protect newer MOSFETs?
5. Describe the procedures that must be observed when handling unprotected MOSFETs.

23-5 TESTING FETs

Testing a field effect transistor is more complicated than testing a normal transistor. The following points must be considered prior to the actual testing of an FET.

1. Is the device a JFET or a MOSFET?
2. Is the FET an N-channel or a P-channel device?

3. With MOSFETs, is the device an enhancement or a depletion mode device?

Before removing an FET from an circuit or handling it, check to see whether it is a JFET or a MOSFET. MOSFETs can be damaged easily unless certain precautions in handling are followed.

1. Keep all of the leads of the MOSFET shorted until ready to use.
2. Make sure the hand used to handle the MOSFET is grounded.
3. Ensure that the power to the circuit is removed prior to insertion or removal of the MOSFET.

Both JFETs and MOSFETs can be tested using commercial transistor test equipment or an ohmmeter.

If using commercial transistor test equipment, refer to the operations manual for proper switch settings.

TESTING JFETs WITH AN OHMMETER

1. Use a low-voltage ohmmeter in the $R \times 100$ range.
2. Determine the polarity of the test leads. Red is positive and black is negative.
3. Determine the forward resistance as follows:
 - a. N-channel JFETs: Connect the positive lead to the gate and the negative lead to the source or drain. Because the source and drain are connected by a channel, only one side needs to be tested. The forward resistance should be a low reading.
 - b. P-channel JFETs: Connect the negative lead to the gate and the positive lead to the source or drain.
4. Determine the reverse resistance as follows:
 - a. N-channel JFETs: Connect the negative test lead of the ohmmeter to the gate and the positive test lead to the source or drain. The JFET should indicate an infinite resistance. A lower reading indicates a short or leakage.

- b. P-channel JFETs: Connect the positive test lead of the ohmmeter to the gate and the negative test lead to the source or drain.

TESTING MOSFETs WITH AN OHMMETER

The forward and reverse resistance should be checked with a low-voltage ohmmeter on its highest scale. MOSFETs have extremely high input resistance because of the insulated gate. The meter should register an infinite resistance in both the forward- and reverse-resistance test between the gate and source or drain. A lower reading indicates a breakdown of the insulation between the gate and source or drain.

23-5 QUESTIONS

1. What questions must be answered prior to the actual testing of an FET?
2. Why is it important to know whether a device is a JFET or a MOSFET before removing it from a circuit?
3. Describe how to test a JFET using an ohmmeter.
4. Describe how to test a MOSFET using an ohmmeter.
5. What procedure is used to test either a JFET or MOSFET with a commercial transistor tester?

SUMMARY

- A JFET uses a channel instead of junctions (as in transistors) for controlling a signal.
- The three leads of a JFET are attached to the gate, source, and drain.
- The input signal is applied between the gate and the source for controlling a JFET.
- JFETs have extremely high input resistance.

- The schematic symbols for JFETs are:



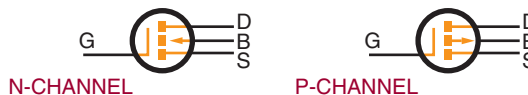
- MOSFETs (insulated gate FETs) isolate the metal gate from the channel with a thin oxide layer.
- Depletion mode MOSFETs are usually N-channel devices and are classified as normally on.
- Enhancement mode MOSFETs are usually P-channel devices and are normally off.
- One difference between JFETs and MOSFETs is that the gate can be made positive or negative on MOSFETs.
- The schematic symbol for a depletion MOSFET is:



- The source and drain leads can be interchanged on most JFETs and

MOSFETs because the devices are symmetrical.

- The schematic symbol for an enhancement MOSFET is:



- MOSFETs must be handled carefully to avoid rupture of the thin oxide layer separating the metal gate from the channel.
- Electrostatic charges from fingers can damage a MOSFET.
- Prior to use, keep the leads of a MOSFET shorted together.
- Wear a grounded metallic wrist strap when handling MOSFETs.
- Use a grounded soldering iron when soldering MOSFETs into a circuit and make sure the power to the circuit is off.
- JFETs and MOSFETs can be tested using a commercial transistor tester or an ohmmeter.

CHAPTER 23 SELF-TEST

- Explain what is meant by pinch-off voltage for an FET.
- How is the pinch-off voltage for a JFET determined?
- Describe what is meant by *depletion-type MOSFET*.
- In what mode of operation is an enhancement MOSFET likely to be cut off?
- Develop a list of safety precautions that must be observed when handling MOSFETs.

Thyristors

OBJECTIVES

After completing this chapter, the student should be able to:

- Identify common types of thyristors.
- Describe how an SCR, TRIAC, or DIAC operates in a circuit.
- Draw and label schematic symbols for an SCR, TRIAC, and DIAC.
- Identify circuit applications of the different types of thyristors.
- Identify the packaging used with the different types of thyristors.
- Test thyristors using an ohmmeter.



See accompanying CD for Thyristor examples in MultiSim, Chapter 24.

Thyristors are a broad range of semiconductor components used for electronically controlled switches. They are semiconductor devices with a bistable action that depends on a PNP regenerative feedback to stay turned on or off. **Bistable action** refers to locking onto one of two stable states. **Regenerative feedback** is a method of obtaining an increased output by feeding part of the output back to the input.

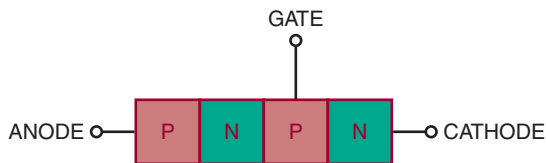
Thyristors are widely used for applications where DC and AC power must be controlled. They are used to apply power to a load or remove power from a load. In addition, they can also be used to regulate power or adjust the amount of power applied to a load—for example, a dimmer control for a light or a motor speed control.

24-1 SILICON-CONTROLLED RECTIFIERS

Silicon-controlled rectifiers are the best known of the thyristors and are generally referred to as **SCRs**. They have three terminals (anode, cathode, and gate) and are used primarily as switches. An SCR is basically a rectifier because it controls current in only one direction. The advantage of the SCR over a power transistor is that it can control a large current, dependent on an external circuit, with a small trigger signal. An SCR requires a current flowing to stay turned on after the gate signal is removed. If the current flow drops to zero, the SCR shuts off and a gate signal must be reapplied

FIGURE 24-1

Simplified SCR.



to turn the SCR back on. A power transistor would require ten times the trigger signal of an SCR to control the same amount of current.

An SCR is a solid-state device consisting of four alternately doped semiconductor layers. It is made from silicon by the diffusion or diffusion-alloy method (see Chapter 20). Figure 24-1 shows a simplified diagram of an SCR. The four layers are sandwiched together to form three junctions. Leads are attached to only three of the layers to form anode, cathode, and gate.

Figure 24-2 shows the four layers divided into two three-layer devices. They are a PNP and an NPN transistor interconnected to form a regenerative feedback pair. Figure 24-3 shows the schematic symbols for these transistors. The figure shows that the anode is positive with respect to

FIGURE 24-2

Equivalent SCR.

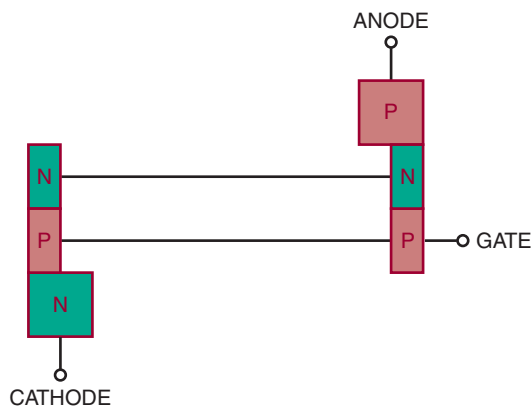
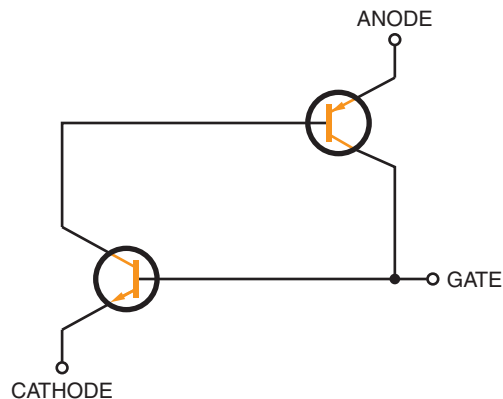


FIGURE 24-3

Schematic representation of an equivalent SCR.



the cathode, and the gate is open. The NPN transistor does not conduct because its emitter junction is not subject to a forward-bias voltage (provided by the PNP transistor's collector or gate signal). Because the NPN transistor's collector is not conducting, the PNP transistor is not conducting (the NPN transistor's collector provides the base drive for the PNP transistor). The circuit does not allow current to flow from the cathode to the anode under these conditions.

If the gate is made positive with respect to the cathode, the emitter junction of the NPN transistor becomes forward biased and the NPN transistor conducts. This causes base current to flow through the PNP transistor, which in turn allows the PNP transistor to conduct. The collector current flowing through the PNP transistor causes the base current to flow through the NPN transistor. The two transistors hold each other in the conducting state, allowing current to flow continuously from the cathode to the anode. This action takes place even though the gate voltage is applied only momentarily. The momentary gate voltage causes the circuit to switch to the conducting state and the circuit to continue conducting even though the gate voltage is removed. The anode current is limited only by the external cir-

cuit. To switch the SCR off, it is necessary to reduce the anode-to-cathode voltage below the hold-on value, typically close to zero. This causes both transistors to turn off and remain off until a gate voltage is again applied.

The SCR is turned on by a positive input gate voltage and turned off by reducing the anode-to-cathode voltage to zero. When the SCR is turned on and is conducting a high cathode-to-anode current, it is conducting in the forward direction. If the polarity of the cathode-to-anode bias voltage is reversed, only a small leakage current flows in the reverse direction.

Figure 24-4 shows the schematic symbol for an SCR. This is a diode symbol with a gate lead attached. The leads are typically identified by the letters *K* (cathode), *A* (anode), and *G* (gate). Figure 24-5 shows several SCR packages.

A properly biased SCR is shown in Figure 24-6. The switch is used to apply and remove gate voltage. The resistor R_G is used to limit current to the

FIGURE 24-4
Schematic symbol for an SCR.



FIGURE 24-5
Common SCR packages.

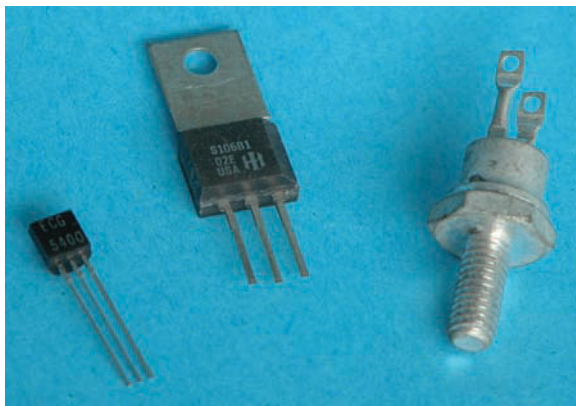
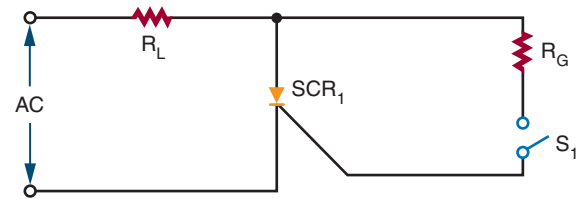


FIGURE 24-6
Properly biased SCR.

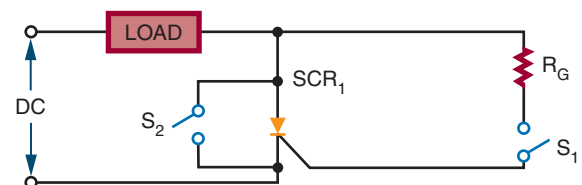


specified gate current. The anode-to-cathode voltage is provided by the AC voltage source. The series resistor (R_L) is used to limit the anode-to-cathode current to the specified gate current when the device is turned on. Without resistor R_L the SCR would conduct an anode-to-cathode current high enough to damage the SCR.

SCRs are used primarily to control the application of DC and AC power to various types of loads. They can be used as switches to open or close circuits. They can also be used to vary the amount of power applied to a load. In using an SCR, a small gate current can control a large load current.

When an SCR is used in a DC circuit, there is no inexpensive method of turning off the SCR without removing power from the load. This problem can be solved by connecting a switch across the SCR (Figure 24-7). When switch S_2 is closed, it shorts out the SCR. This reduces the anode-to-cathode voltage to zero, reducing the forward current to below the holding value, and turning off the SCR.

FIGURE 24-7
Removing power in a DC circuit.



When an SCR is used in an AC circuit it is capable of conducting only one of the alternations of each AC input cycle, the alternation that makes the anode positive with respect to the cathode. When the gate current is applied continuously, the SCR conducts continuously. When the gate current is removed, the SCR turns off within one-half of the AC signal and remains off until the gate current is reapplied. It should be noted that this means only half of the available power is applied to the load. It is possible to use the SCR to control current during both alternations of each cycle. This is accomplished by rectifying the AC signal so that both alternations of each cycle are made to flow in the same direction before being applied to the SCR.

Figure 24–8 shows a simple variable half-wave circuit. The circuit provides a phase shift from 0 to 90 electrical degrees of the anode voltage signal. Diode D_1 blocks the reverse gate voltage on the negative half-cycle of the anode supply voltage.

24–1 QUESTIONS

1. Why is an SCR considered better for switching than a transistor?
2. Describe how an SCR is constructed.
3. Explain how an SCR operates.
4. Draw and label the schematic symbol for an SCR.
5. What are some applications of an SCR?

FIGURE 24–8

Variable half-wave circuit.

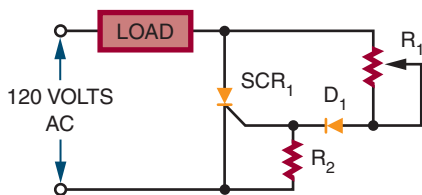
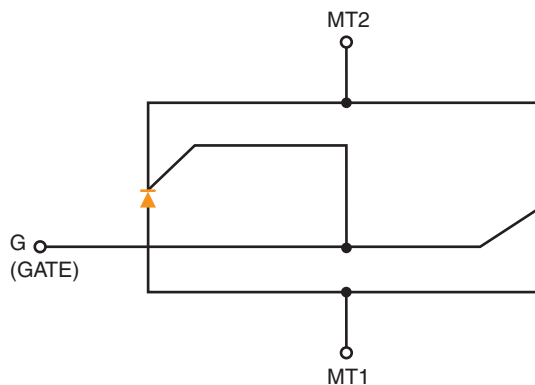


FIGURE 24–9

Equivalent TRIAC.



24–2 TRIACs

TRIAC is an acronym for *triode AC* semiconductor. TRIACs have the same switching characteristics as SCRs but conduct both directions of AC current flow. A TRIAC is equivalent to two SCRs connected in parallel, back to back (Figure 24–9).

Because a TRIAC can control current flowing in either direction, it is widely used to control application of AC power to various types of loads. It can be turned on by applying a gate current and turned off by reducing the operating current to below the holding level. It is designed to conduct forward and reverse current through the terminals.

Figure 24–10 shows a simplified diagram of a TRIAC. A TRIAC is a four-layer NPNP device in parallel with a PNP device. It is designed to respond to a gating current through a single gate. The input and output terminals are identified as *main terminal 1 (MT1)* and *main terminal 2 (MT2)*. The terminals are connected across the PN junctions at the opposite ends of the device. Terminal MT1 is the reference point for measurement of voltage and current at the gate terminal. The gate (G) is connected to the PN junction at the same end as MT1. From MT1 to MT2, the signal must

FIGURE 24-10

Simplified TRIAC.

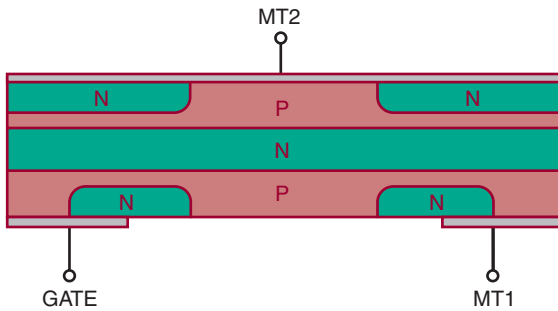
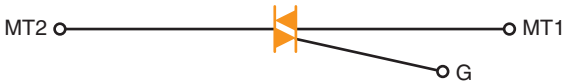


FIGURE 24-11

Schematic symbol for a TRIAC.



pass through an NPN series of layers or a PNP series of layers.

The schematic symbol for a TRIAC is shown in Figure 24-11. It consists of two parallel diodes connected in opposite directions with a single gate lead. The terminals are identified as MT1, MT2, and G (gate). Several TRIAC packages are shown in Figure 24-12.

A TRIAC can be used as an AC switch (Figure 24-13). It can also be used to control the amount of AC power applied to a load (Figure 24-14). TRIACs apply all available power to the load. When a TRIAC is used to vary the amount of AC power applied to the load, a special triggering device is needed to ensure that the TRIAC functions at the proper time. The triggering device is necessary because the TRIAC is not equally sensitive to the gate current flowing in opposite directions.

TRIACs have disadvantages when compared to SCRs. TRIACs have current ratings as high as 25 amperes, but SCRs are available with current

FIGURE 24-12

Common TRIAC packages.

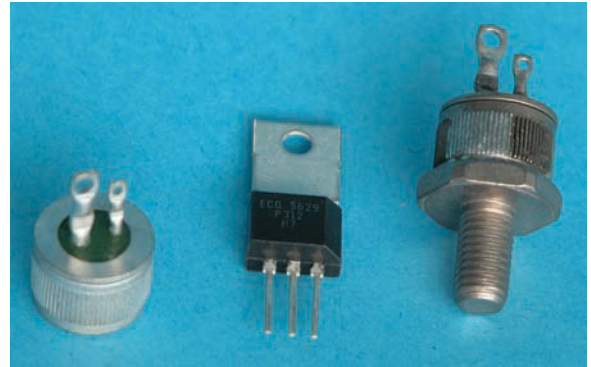


FIGURE 24-13

TRIAC AC switch circuit.

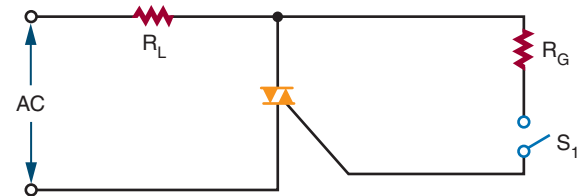
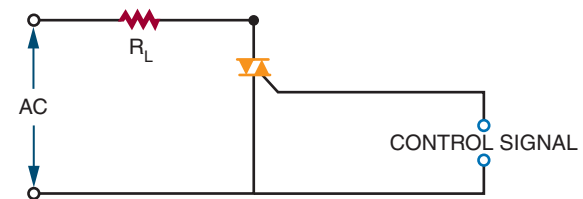


FIGURE 24-14

TRIAC AC control circuit.



ratings as high as 1400 amperes. A TRIAC's maximum voltage rating is 500 volts, compared to an SCR's 2600 volts. TRIACs are designed for low frequency (50 to 400 hertz) whereas SCRs can handle up to 30,000 hertz. TRIACs also have difficulty switching power to inductive loads.

24-2 QUESTIONS

1. What is the difference between a TRIAC and an SCR?
2. Describe how a TRIAC is constructed.
3. Draw and label the schematic symbol for a TRIAC.
4. What are some applications of a TRIAC?
5. Compare the advantages and disadvantages of TRIACs and SCRs.

24-3 BIDIRECTIONAL TRIGGER DIODES

Bidirectional (two-directional) trigger diodes are used in TRIAC circuits because TRIACs have non-symmetrical triggering characteristics; that is, they are not equally sensitive to gate current flowing in opposite directions. The most frequently used triggering device is the **DIAC** (*diode AC*).

The DIAC is constructed in the same manner as the transistor. It has three alternately doped layers (Figure 24-15). The only difference in the construction is that the doping concentration around both junctions in the DIAC is equal. Leads are only attached to the outer layers. Because there are only two leads, the device is packaged like a PN junction diode.

Both junctions are equally doped, so a DIAC has the same effect on current regardless of the direction of flow. One of the junctions is forward biased and the other is reverse biased. The reverse-biased junction controls the current flow-

FIGURE 24-15

Simplified DIAC.



FIGURE 24-16

Equivalent DIAC.



(CAN BE INSTALLED IN EITHER DIRECTION)

ing through the DIAC. The DIAC performs as if it contains two PN junction diodes connected in series back to back (Figure 24-16). The DIAC remains in the off state until an applied voltage in either direction is high enough to cause its reverse-biased junction to break over and start conducting much like a zener diode. *Break over* is the point at which conduction starts to occur. This causes the DIAC to turn on and the current to rise to a value limited by a series resistor in the circuit.

The schematic symbol for a DIAC is shown in Figure 24-17. It is similar to the symbol for a TRIAC. The difference is that a DIAC does not have a gate lead.

DIACs are most commonly used as a triggering device for TRIACs. Each time the DIAC turns on, it allows current to flow through the TRIAC gate, thus turning the TRIAC on. The DIAC is used in conjunction with the TRIAC to provide full-wave control of AC signals.

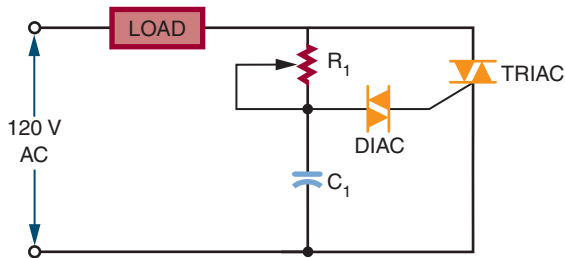
Figure 24-18 shows a variable full-wave phase-control circuit. Variable resistor R_1 and capacitor C_1 form a phase-shift network. When the voltage across C_1 reaches the breakover voltage of the DIAC, C_1 partially discharges through the DIAC into the gate of the TRIAC. This discharge creates a pulse that triggers the TRIAC into conduction. This circuit is useful for controlling lamps, heaters, and speeds of small electrical motors.

FIGURE 24-17

Schematic symbol for a DIAC.



FIGURE 24-18
Variable full-wave phase-control circuit.



24-3 QUESTIONS

1. Where are DIACs used in circuits?
2. Describe how a DIAC is constructed.
3. Explain how a DIAC works in a circuit.
4. Draw the schematic symbol for a DIAC.
5. Draw the schematic for a full-wave phase-control circuit using DIACs and TRIACs.

24-4 TESTING THYRISTORS

Like other semiconductor devices, thyristors may fail. They can be tested with commercial test equipment or with an ohmmeter.

To use commercial test equipment for testing thyristors, refer to the operator's manual for proper switch settings and readings.

An ohmmeter can detect the majority of defective thyristors. It cannot detect marginal or voltage-sensitive devices. It can, however, give a good indication of the condition of the thyristor.

TESTING SCRs WITH AN OHMMETER

1. Determine the polarity of the ohmmeter leads. The red lead is positive and the black lead is negative.

2. Connect the ohmmeter leads, positive to the cathode and negative to the anode. The resistance should exceed 1 megohm.
3. Reverse the leads, negative to the cathode and positive to the anode. The resistance should again exceed 1 megohm.
4. With the ohmmeter leads connected as in step 3, short the gate to the anode (touch the gate lead to the anode lead). The resistance should drop to less than 1 megohm.
5. Remove the short between the gate and the anode. If a low-resistance range of the ohmmeter is used, the resistance should stay low. If a high-resistance range is used, the resistance should return to above 1 megohm. In the higher resistance ranges, the ohmmeter does not supply enough current to keep the gate latched (turned on) when the short is removed.
6. Remove the ohmmeter leads from the SCR and repeat the test. Because some ohmmeters do not give significant results on step 5, step 4 is sufficient.

TESTING TRIACs WITH AN OHMMETER

1. Determine the polarity of the ohmmeter leads.
2. Connect the positive lead to MT1 and the negative lead to MT2. The resistance should be high.
3. With the leads still connected as in step 2, short the gate to MT1. The resistance should drop.
4. Remove the short. The low resistance should remain. The ohmmeter may not supply enough current to keep the TRIAC latched if a large gate current is required.
5. Remove the leads and reconnect as specified in step 2. The resistance should again be high.
6. Short the gate to MT2. The resistance should drop.

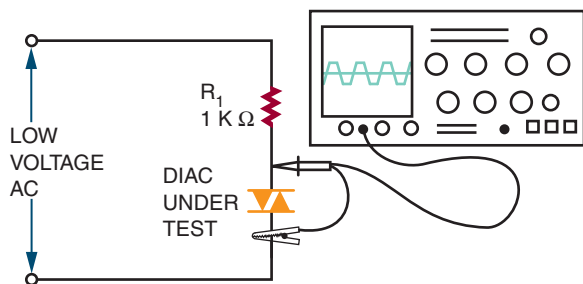
7. Remove the short. The low resistance should remain.
8. Remove and reverse the leads, the negative lead to MT1 and the positive lead to MT2. The resistance should read high.
9. Short the gate to MT1. The resistance should drop.
10. Remove the short. The low resistance should remain.
11. Remove the leads and reconnect in the same configuration. The resistance should again be high.
12. Short the gate to MT2. The resistance should drop.
13. Remove the short. The low resistance should remain.
14. Remove and reconnect the leads. The resistance should be high.

TESTING DIACs WITH AN OHMMETER

In testing DIACs with an ohmmeter, a low resistance in either direction indicates that the device is not opened (defective). This does not indicate a shorted device. Further testing of the DIAC requires a special circuit setup to check the voltage at the terminals (Figure 24–19).

FIGURE 24–19

Dynamic DIAC test.

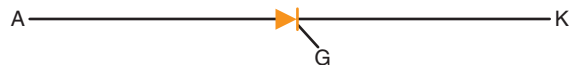


24–4 QUESTIONS

1. Describe the switch settings and indications for using a transistor tester for testing an SCR. (Refer to the manual.)
2. Describe the switch settings and indications for using a transistor tester for testing a TRIAC. (Refer to the manual.)
3. Describe the procedure for testing an SCR with an ohmmeter.
4. Describe the procedure for testing a TRIAC with an ohmmeter.
5. Describe the procedure for testing a DIAC with an ohmmeter.

SUMMARY

- Thyristors include SCRs (silicon-controlled rectifiers), TRIACs, and DIACs.
- An SCR controls current in one direction by a positive gate signal.
- An SCR is turned off by reducing the anode-to-cathode voltage to zero.
- SCRs can be used to control current in both AC and DC circuits.
- The schematic symbol for an SCR is:



- TRIACs are bidirectional triode thyristors.
- TRIACs control current in either direction by either a positive or negative gate signal.
- The schematic symbol for a TRIAC is:



- SCRs can handle up to 1400 A compared to 25 A for TRIACs.
- SCRs have voltage ratings up to 2600 V compared to 500 V for TRIACs.
- SCRs can handle frequencies of up to 30,000 hertz compared to 400 hertz for TRIACs.
- Because TRIACs have nonsymmetrical triggering characteristics, they require the use of a DIAC.
- DIACs are bidirectional trigger diodes.
- The schematic symbol for a DIAC is:



- DIACs are mostly used as triggering devices for TRIACs.
- Thyristors can be tested using commercial transistor testers or ohmmeters.

CHAPTER 24 SELF-TEST

1. What is the difference between a PN junction diode and an SCR?
2. After the SCR has been turned on, what effect does the anode supply voltage have on the anode current that flows through the SCR?
3. What effect does the load resistance have on the current flowing through an SCR circuit?
4. Describe the process for testing an SCR.
5. Why is a DIAC used in the gate circuit of a TRIAC?

Integrated Circuits

OBJECTIVES

After completing this chapter, the student should be able to:

- Explain the importance of integrated circuits.
- Identify advantages and disadvantages of integrated circuits.
- Identify the major components of an integrated circuit.
- Describe the four processes used to construct integrated circuits.
- Identify the major integrated circuit packages.
- List the families of integrated circuits.

Transistors and other semiconductor devices have made it possible to reduce the size of electronic circuits because of their small size and low power consumption. It is now possible to extend the principles behind semiconductors to complete circuits as well as individual components. The goal of the integrated circuit is to develop a single device to perform a specific function, such as amplification or switching, eliminating the separation between components and circuits.

Several factors have made the integrated circuit popular:

- It is reliable with complex circuits.
- It meets the need for low power consumption.
- It offers small size and weight.
- It is economical to produce.
- It offers new and better solutions to system problems.

25-1 INTRODUCTION TO INTEGRATED CIRCUITS

The first integrated circuit was conceived by Geoffrey W. A. Dummer, a radar scientist for the Royal Radar Establishment of the British Ministry of Defense. He published his idea in Washington, D.C., on May 7, 1952. But by 1956, he had still failed to build a successful circuit based on his model.

At Texas Instruments Jack Kilby was assigned in the summer of 1958 to develop a smaller electrical circuit. His idea evolved to fabricating all the components and the chip out of the same block (monolith) of semiconductor material. In September 1958, he constructed the first integrated circuit and it worked perfectly. Making all the parts out of the same block of material and adding the metal needed to connect them as a top layer resulted in not needing individual discrete components and wires. The circuits could be made smaller and the manufacturing process could be automated. Jack Kilby is probably most famous for his invention of the integrated circuit, for which he received the Nobel Prize in Physics in the year 2000.

Robert Noyce of Fairchild Semiconductor independently developed his own idea for integrated circuit construction a half a year later than Jack Kilby. Noyce's circuit solved Kirby's problem of interconnecting all the components on the chip. He added the metal as a final layer and then removed some of it so that the wires needed to connect the components were formed. This made the integrated circuit suitable for mass production.

Today, an **integrated circuit (IC)** is a complete electronic circuit in a package no larger than that of a conventional low-power transistor. The circuit consists of diodes, transistors, resis-

tors, and capacitors. Integrated circuits are produced with the same technology and materials used in making transistors and other semiconductor devices.

The most obvious advantage of the integrated circuit is its small size. An integrated circuit is constructed of a chip of semiconductor material approximately one-eighth of an inch square. It is because of the integrated circuit's small size that it finds extensive use in military and aerospace programs. The integrated circuit has also transformed the calculator from a desktop to a handheld instrument. Computer systems, once the size of rooms, are now available in portable models because of integrated circuits.

This small, integrated circuit consumes less power and operates at higher speeds than a conventional transistor circuit. The electron travel time is reduced by direct connection of the internal components.

Integrated circuits are more reliable than directly connected transistor circuits. In the integrated circuit, internal components are connected permanently. All the components are formed at the same time, reducing the chance for error. After the integrated circuit is formed, it is pretested before final assembly.

Many integrated circuits are produced at the same time. This results in substantial cost savings. Manufacturers offer a complete and standard line of integrated circuits. Special-purpose integrated circuits can still be produced to specification, but this results in higher costs if quantities are small.

Integrated circuits reduce the number of parts needed to construct electronic equipment. This reduces inventory, resulting in less overhead for the manufacturer and further reducing the cost of electronic equipment.

Integrated circuits do have some disadvantages. They cannot handle large amounts of current or voltage. High current generates excessive

heat, damaging the device. High voltage breaks down the insulation between the various internal components. Most integrated circuits are low-power devices, consuming from 5 to 15 volts in the milliamp range. This results in power consumption of less than 1 watt.

Only four types of components are included in integrated circuits: diodes, transistors, resistors, and capacitors. Diodes and transistors are the easiest to construct. Resistors increase in size as they increase in resistance. Capacitors require more space than resistors and also increase in size as their capacity increases.

Integrated circuits cannot be repaired. This is because the internal components cannot be separated. Therefore, problems are identified by individual circuit instead of by individual component. The advantage of this disadvantage is that it greatly simplifies maintaining highly complex systems. It also reduces the amount of time required for maintenance personnel to service equipment.

When all factors are considered, the advantages outweigh the disadvantages. Integrated circuits reduce the size, weight, and cost of electronic equipment while increasing its reliability. As integrated circuits become more sophisticated, they become capable of performing a wider range of tasks.

25-1 QUESTIONS

1. Define *integrated circuit*.
2. What are the advantages of integrated circuits?
3. What are the disadvantages of integrated circuits?
4. What components can be included in integrated circuits?
5. What is the procedure for repairing a faulty integrated circuit?

25-2 INTEGRATED CIRCUIT CONSTRUCTION TECHNIQUES

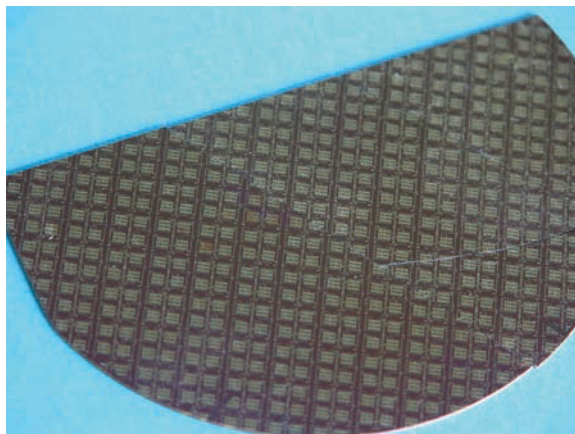
Integrated circuits are classified according to their construction techniques. The more common construction techniques are monolithic, thin film, thick film, and hybrid.

Monolithic integrated circuits are constructed in the same manner as transistors but include a few additional steps. The integrated circuit begins with a circular silicon wafer 3 to 4 inches in diameter and about 0.010 inch thick. This serves as a substrate (base) on which the integrated circuits are formed. Many integrated circuits are formed at the same time on this wafer, up to several hundred, depending on the size of the wafer. The integrated circuits on the wafer are generally all the same size and type and contain the same number and type of components (Figure 25-1).

After fabrication, the integrated circuits are tested on the wafer. After testing, the wafer is sliced into individual chips. Each chip represents one complete integrated circuit containing all the components and connections associated with that circuit. Each chip that passes quality-control

FIGURE 25-1

Integrated circuits on wafer.



tests is then mounted into a package. Even though a large number of integrated circuits are fabricated at the same time, only a certain number are usable. This is referred to as the yield. The *yield* is the maximum number of usable integrated circuits compared with the rejects.

Thin-film integrated circuits are formed on the surface of an insulating substrate of glass or ceramic, usually less than an inch square. The components (resistors and capacitors) are formed by an extremely thin film of metal and oxides deposited on the substrate. Thin strips of metal are then deposited to connect the components. Diodes and transistors are formed as separate semiconductor devices and attached in the proper location. Resistors are formed by depositing tantalum or nichrome on the surface of the substrate in a thin film 0.0001 inch thick. The value of the resistor is determined by the length, width, and thickness of each strip. Conductors are formed of low-resistance metal such as gold, platinum, or aluminum. This process can produce a resistor accurate to within $\pm 0.1\%$. It can also obtain a ratio between resistors accurate to $\pm 0.01\%$. Accurate ratios are important for the proper operation of a particular circuit.

Thin-film capacitors consist of two thin layers of metal separated by an extremely thin dielectric. A metal layer is deposited on the substrate. An oxide coating is then formed over the metal for a dielectric. The dielectric is formed from an insulating material such as tantalum oxide, silicon oxide, or aluminum oxide. The top plate, formed from gold, tantalum, or platinum, is deposited on the dielectric. The capacitor value is obtained by adjusting the area of the plate and by varying the thickness and type of dielectric.

Diode and transistor chips are formed using the monolithic technique. The diode and transistor chips are permanently mounted on the substrate. They are then electrically connected to the thin-film circuit using extremely thin wires.

The materials used for components and conductors are deposited on the substrate using an evaporation or sputtering process. The *evaporation*

process requires that the material deposited on the substrate be placed in a vacuum and heated until it evaporates. The vapors are then allowed to condense on the substrate forming a thin film.

The *sputtering process* subjects a gas-filled chamber to a high voltage. The high voltage ionizes the gas, and the material to be deposited is bombarded with ions. This dislodges the atoms within the material, which drift toward the substrate where they are deposited as a thin film. A mask is used to ensure proper location of the film deposit. Another method is to coat the substrate completely and cut or etch away the undesired portions.

In thick-film construction, the resistors, capacitors, and conductors are formed on the substrate using a screen printing process: A fine wire screen is placed over the substrate and metallized ink is forced through the screen with a squeegee. The screen acts as a mask. The substrate and ink are then heated to over 600 degrees celsius to harden the ink.

Thick-film capacitors have low values (in picofarads). When a higher value is required, discrete capacitors are used. The thick-film components are 0.001 inch thick; they have no discernable thickness. The thick-film components resemble conventional discrete components.

Hybrid integrated circuits are formed using monolithic, thin-film, thick-film, and discrete components. This allows for a high degree of circuit complexity by using monolithic circuits while at the same time taking advantage of extremely accurate component values and tolerances with the film techniques. Discrete components are used because they can handle relatively large amounts of power.

If only a few circuits are to be made, it is cheaper to use hybrid integrated circuits. The major expense in hybrid construction is the wiring and assembly of components and the final packaging of the device. Because hybrid circuits use discrete components, they are larger and heavier than monolithic integrated circuits. The use of discrete components tends to make hybrid circuits less reliable than monolithic circuits.

25-2 QUESTIONS

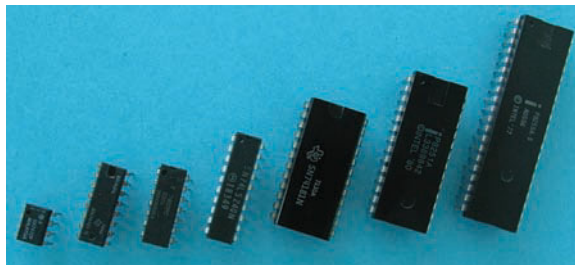
1. What methods are used to construct integrated circuits?
2. Describe the monolithic process of integrated circuit fabrication.
3. What are the differences between thin-film and thick-film fabrication processes?
4. How is a hybrid integrated circuit constructed?
5. What determines which process will be used when fabricating an integrated circuit?

25-3 INTEGRATED CIRCUIT PACKAGING

An integrated circuit is a thin chip consisting of hundreds to millions of interconnected semiconductor devices such as transistors, resistors, and capacitors. In 2004, a typical chip size of 1 cm² or smaller was common, although larger sizes were also produced.

Integrated circuits are mounted in packages designed to protect them from moisture, dust, and other contaminants. The most popular package design is the **dual-inline package (DIP)** (Figure 25-2). DIPs are manufactured in several sizes to accommodate the various sizes of integrated circuits: *small-scale integration* (SSI) with up to 100 electrical components per chip (early 1960s), *medium-scale integration* (MSI) with 100 to 3,000 electrical components per chip (late 1960s), *large-scale integration* (LSI) with 3,000 to 100,000 electrical components per chip (mid 1970), and *very large-scale integration* (VLSI) with 100,000 to 1,000,000 electrical components per chip (1980s). ULSI stands for *ultra-large scale integration* and provides no quali-

FIGURE 25-2
Integrated Circuit Dual Inline Packages.



tative leap from VLSI, but is reserved to emphasize chip complexity in marketing. Integrated circuit families are shown in Figure 25-3.

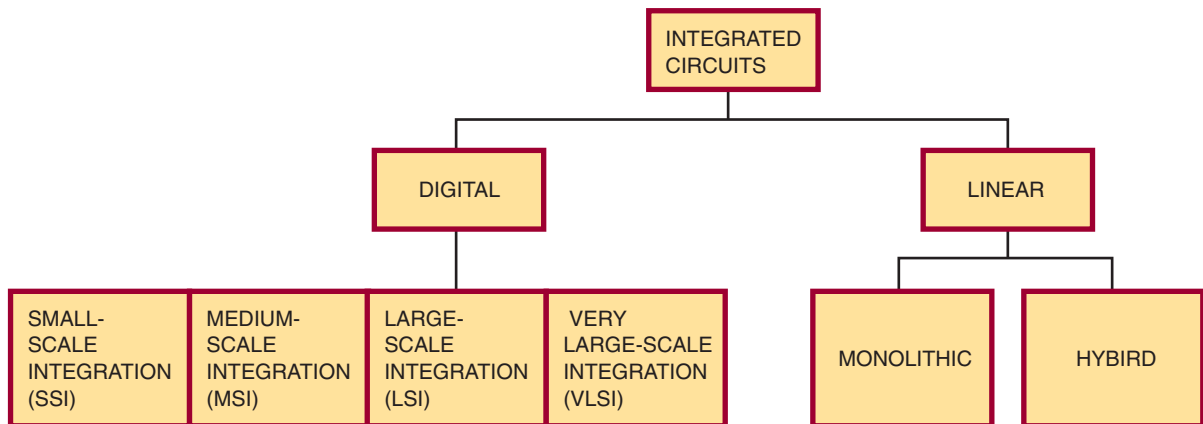
Wafer-scale integration (WSI), which uses uncut wafers containing entire computer systems including memory, was developed in the 1980s. It failed because of problems with creating a defect-free manufacturing process. WSI was followed by *system-on-chip* (SOC) design. This process takes components that were typically manufactured on separate chips and wired together on a printed circuit board and designs them to occupy a single chip that contains the whole electronic system: microprocessor, memory, peripheral interface, input/output logic control, a/d converters, and so on.

The pin count of the VLSI circuits in the 1980s exceeded the practical limits for DIP packaging. This led to pin grid array (PGA) and leadless chip carriers (LCC) packages. Surface-mount packaging, which uses a fine lead pitch, became popular in the late 1980s. In the late 1990s, high pin count devices used Plastic Quad Flat Package (PQFP) and Thin Small Outline Package (TSOP) packaging.

The package is made in either ceramic or plastic. Plastic is less expensive and suitable for most applications where the operating temperature falls between 0 to 70 degrees celsius. Ceramic devices are more expensive but offer better protection against moisture and contamination. They also operate in a wider range of temperatures

FIGURE 25-3

Families of integrated circuits.



(−55 to +125 degrees celsius). Ceramic devices are recommended for military, aerospace, and severe industrial applications.

A small 8-pin DIP, called a mini-DIP, is used for devices with a minimum number of inputs and outputs. It is used mostly with monolithic integrated circuits.

A flat-pack is smaller and thinner than a DIP and is used where space is limited. It is made from metal or ceramic and operates in a temperature range of −55 to +125 degrees celsius.

After the integrated circuit is packaged, it is tested to ensure that it meets all electrical specifications. It is tested over a wide range of temperatures.

25-3 QUESTIONS

1. What are the functions of an integrated circuit package?
2. What package is most often used for integrated circuits?
3. What materials are used for integrated circuit packages?

4. What are the advantages of ceramic packages?

5. What is the advantage of the flat-pack integrated circuit package?

SUMMARY

- Integrated circuits are popular because they:
 - Are reliable with complex circuits
 - Consume little power
 - Are small and light
 - Are economical to produce
 - Provide new and better solutions to problems
- Integrated circuits cannot handle large amounts of current or voltage.
- Only diodes, transistors, resistors, and capacitors are available as integrated circuits.
- Integrated circuits cannot be repaired, only replaced.
- Integrated circuits are constructed by monolithic, thin-film, thick-film, or hybrid techniques.

- The most popular integrated circuit package is the DIP (dual-inline package).
- Integrated circuit packages are made of ceramic or plastic, with plastic most often used.

CHAPTER 25 SELF-TEST

1. What components does a hybrid integrated circuit contain?
2. What is identified by the word “chip”?
3. In fabricating an integrated circuit using the monolithic construction method, what is the problem with resistors and capacitors?

Optoelectric Devices

OBJECTIVES

After completing this chapter, the student should be able to:

- Identify the three categories of semiconductor devices that react to light.
- Classify the major frequency ranges of light.
- Identify major light-sensitive devices and describe their operation and applications.
- Identify major light-emitting devices and describe their operation and applications.
- Draw and label the schematic symbols associated with optoelectric devices.
- Identify packages used for optoelectric devices.

Semiconductors in general, and semiconductor diodes in particular, have important uses in optoelectronics. Here, a device is designed to interact with electromagnetic radiation (light energy) in the visible, infrared, and ultraviolet ranges.

Three types of devices interact with light:

- Light-detection devices
- Light-conversion devices
- Light-emitting devices

The semiconductor material and the doping techniques used determine the relevant light wave-length of a particular device.

26-1 BASIC PRINCIPLES OF LIGHT

Light is electromagnetic radiation that is visible to the human eye. Light is thought to travel in a form similar to radio waves. Like radio waves, light is measured in wavelengths.

Light travels at 186,000 miles per second or 30,000,000,000 centimeters per second through a vacuum. The velocity is reduced as it passes through various types of mediums. The frequency range of light is 300 to 300,000,000 gigahertz (giga = 1,000,000,000). Of this frequency range only a small band is visible to the human eye. The visible region spans from approximately 400,000 to 750,000 gigahertz. Infrared light falls below 400,000 gigahertz and ultraviolet light lies above 750,000 gigahertz. Light waves at the upper end of the frequency range have more energy than light waves at the lower end.

26-1 QUESTIONS

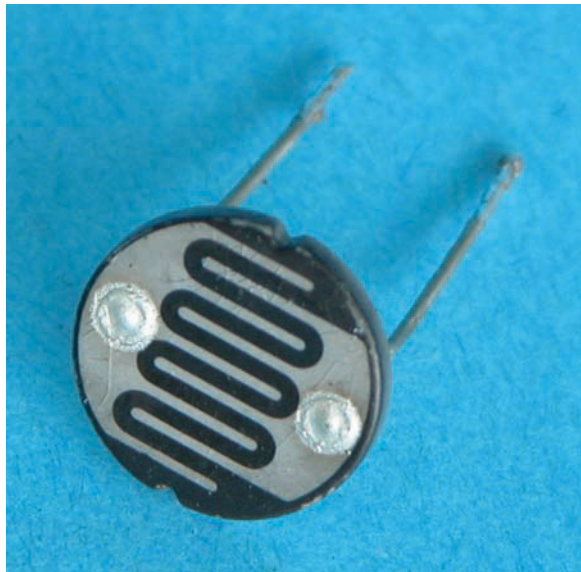
1. What is light?
2. What frequency range of light is visible to the human eye?
3. What is infrared light?
4. What is ultraviolet light?
5. What type of light wave has the most energy?

26-2 LIGHT-SENSITIVE DEVICES

The **photoconductive cell (photo cell)** is the oldest optoelectric device. It is a light-sensitive device in which the internal resistance changes with a change in light intensity. The resistance change is not proportional to the light striking it. The photo

FIGURE 26-1

Photo cell.



cell is made from light-sensitive material such as cadmium sulfide (CdS) or cadmium selenide (CdSe).

Figure 26-1 shows a typical photo cell. The light-sensitive material is deposited on an insulating substrate of glass or ceramic in an S-shape to allow greater contact length. The photo cell is more sensitive to light than any other device. The resistance can vary from several hundred million ohms to several hundred ohms. The photo cell is useful for low-light applications. It can stand high operating voltages of 200 to 300 volts with a low power consumption of up to 300 milliwatts. A disadvantage of the photo cell is its slow response to light change.

Figure 26-2 shows the schematic symbols used to represent a photo cell. The arrows indicate a light-sensitive device. Sometimes the Greek letter lambda (λ) is used to represent a light-sensitive device.

Photo cells are used in light meters for photographic equipment, instruction detectors, auto-

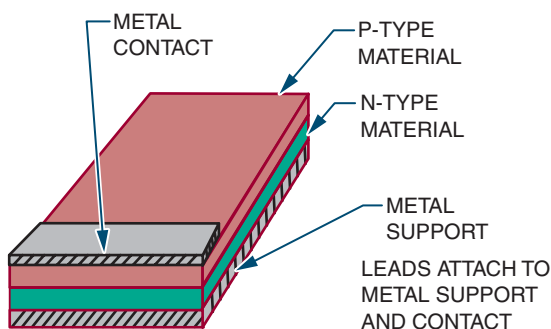
FIGURE 26-2

Schematic symbols for a photo cell.



FIGURE 26-3

Construction of a solar cell.



matic door openers, and various kinds of test equipment to measure light intensity.

The **photovoltaic cell (solar cell)** converts light energy directly into electrical energy. The solar cell finds most of its applications in converting solar energy into electrical energy.

The solar cell is basically a PN junction device made from semiconductor materials. It is most commonly made from silicon. Figure 26-3 shows the construction technique. The P and N layers form a PN junction. The metal support and the metal contact act as the electrical contacts. It is designed with a large surface area.

The light striking the surface of the solar cell imparts much of its energy to the atoms in the semiconductor material. The light energy knocks valence electrons from their orbits, creating free electrons. The electrons near the depletion region are drawn to the N-type material, producing a small voltage across the PN junction. The voltage increases with an increase in light intensity. All

FIGURE 26-4

Schematic symbols for a solar cell.

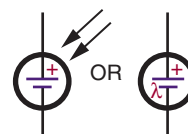
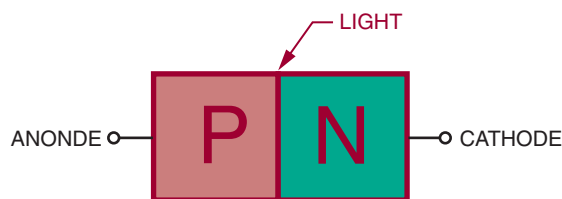


FIGURE 26-5

PN junction photodiode.



the light energy striking the solar cell does not create free electrons, however. In fact, the solar cell is a highly inefficient device, with a top efficiency of 15 to 20%. The cell is inefficient when expressed in terms of electrical power output compared to the total power contained in the input light energy.

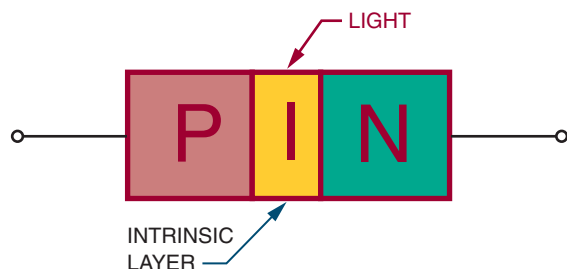
Solar cells have a low voltage output of about 0.45 volt at 50 milliamperes. They must be connected in a series and parallel network to obtain the desired voltage and current output.

Applications include light meters for photographic equipment, motion-picture projector soundtrack decoders, and battery chargers on satellites.

Schematic symbols for the solar cell are shown in Figure 26-4. The positive terminal is identified with a plus (+) sign.

The **photodiode** also uses a PN junction and has a construction similar to that of the solar cell. It is used the same way as the photo cell, as a light-variable resistor. **Photodiodes** are semiconductor devices that are made primarily from silicon. They are constructed in two ways. One method is as a simple PN junction (Figure 26-5). The other

FIGURE 26-6
PIN junction photodiode.



method inserts an intrinsic (undoped) layer between the P and N region (Figure 26-6), forming a PIN photodiode.

A PN junction photodiode operates on the same principles as a photovoltaic cell except that it is used to control current flow, not generate it. A reverse-bias voltage is applied across the photodiode, forming a wide depletion region. When light energy strikes the photodiode, it enters the depletion region, creating free electrons. The electrons are drawn toward the positive side of the

bias source. A small current flows through the photodiode in the reverse direction. As the light energy increases, more free electrons are generated, creating more current flow.

A **PIN photodiode** has an intrinsic layer between the P and N regions. This effectively extends the depletion region. The wider depletion region allows the PIN photodiode to respond to lower light frequencies. The lower light frequencies have less energy and so must penetrate deeper into the depletion region before generating free electrons. The wider depletion region offers a greater chance of free electrons being generated. The PIN photodiode is more efficient over a wide range.

The PIN photodiode has a lower internal capacitance because of the intrinsic layer. This allows for a faster response to changes in light intensity. Also, a more linear change in reverse current with light intensity is produced.

The advantage of the photodiode is fast response to light changes, the fastest of any photosensitive device. The disadvantage is a low output compared to other photosensitive devices.

Figure 26-7 shows a typical photodiode package. A glass window allows light energy to strike the

FIGURE 26-7
Photodiode package.

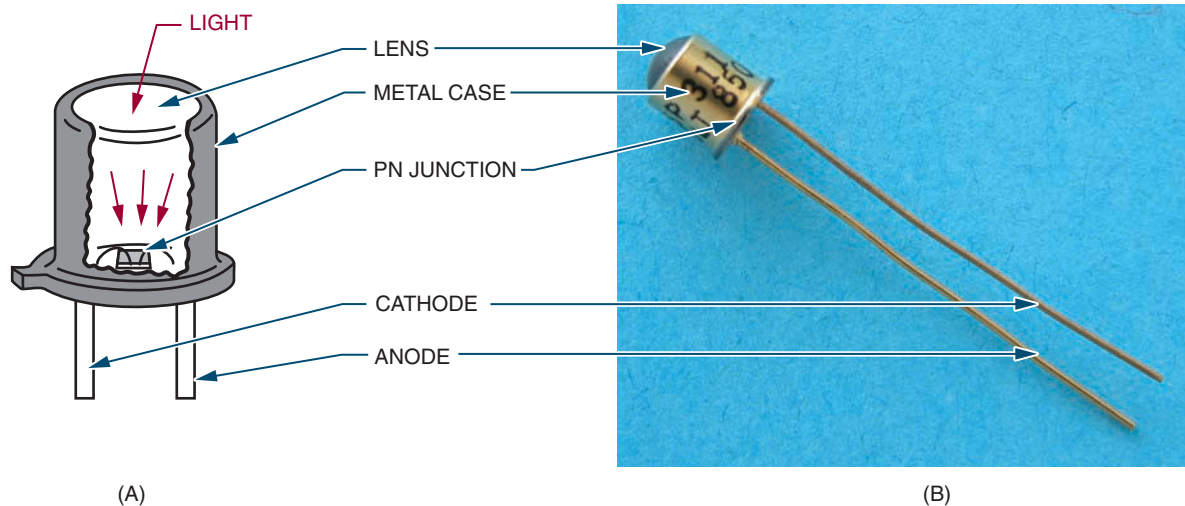


FIGURE 26-8

Schematic symbol for a photodiode.



FIGURE 26-9

Voltage divider using a photodiode.

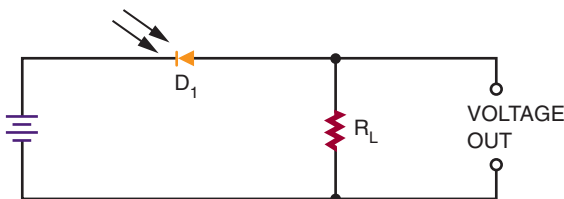
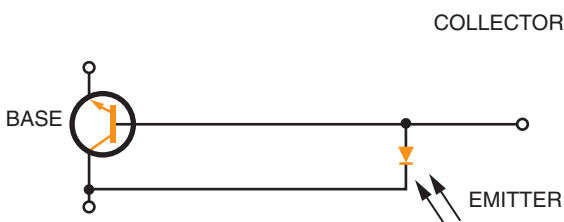


FIGURE 26-10

Equivalent circuit for a phototransistor.



photodiode. The schematic symbol is shown in Figure 26-8. A typical circuit is shown in Figure 26-9.

A **phototransistor** is constructed like other transistors with two PN junctions. It resembles a standard NPN transistor. It is used like a photodiode and packaged like a photodiode, except that it has three leads (emitter, base, and collector). Figure 26-10 shows the equivalent circuit. The transistor conduction depends on the conduction of the photodiode. The base lead is seldom used. When it is used, its purpose is to adjust the turn-on point of the transistor.

Phototransistors can produce higher output current than photodiodes. Their response to light changes is not as fast as that of the pho-

FIGURE 26-11

Schematic symbol for a phototransistor.

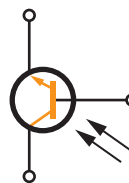
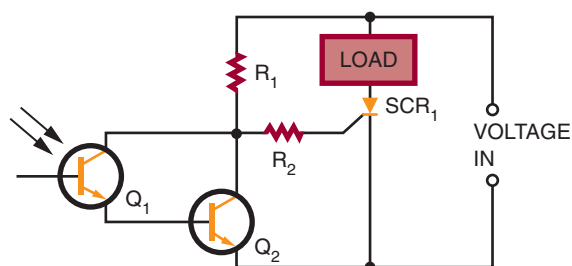


FIGURE 26-12

Darkness-on DC switch.



todiode. There is a sacrifice of speed for a higher output current.

Applications include phototachometers, photographic exposure controls, flame detectors, object counters, and mechanical positioners.

Figure 26-11 shows the schematic symbol for a phototransistor. Figure 26-12 shows a typical circuit application.

26-2 QUESTIONS

1. Explain how a photoconductive cell operates.
2. Explain how a solar cell functions.
3. What is the difference between the two types of photodiodes?
4. How is the phototransistor an improvement over the photodiode?
5. Draw and label the schematic symbols for a photoconductive cell, solar cell, photodiode, and phototransistor.

26-3 LIGHT-EMITTING DEVICES

Light-emitting devices produce light when subject to a current flow, converting electrical energy to light energy. A **light-emitting diode (LED)** is the most common semiconductor light-emitting device. Being a semiconductor component, it has an unlimited life span due to the absence of a filament, a cause of trouble in conventional lamps.

Any PN junction diode can emit light when subject to an electrical current flow. The light is produced when the free electrons combine with holes and the extra energy is released in the form of light. The frequency of the light emitted is determined by the type of semiconductor material used in construction of the diode. Regular diodes do not emit light because of the opaque material used in their packaging.

An LED is simply a PN junction diode that emits light when a current flows through its junction. The light is visible because the LED is packaged in semitransparent material. The frequency of the light emitted depends on the material used in the construction of the LED. Gallium arsenide (GaAs) produces light in the infrared region, which is invisible to the human eye. Gallium arsenide phosphide (GaAsP) emits a visible red light. By changing the phosphide content, different frequencies of light can be produced.

Figure 26-13 shows the construction of an LED. The P layer is made thin so that light energy near the PN junction only needs to travel a short distance through it.

After the LED is formed, it is mounted in a package designed for optimum emission of light. Figure 26-14 shows some of the more common LED packages. Most LEDs contain a lens that gathers and intensifies the light. The case may act as a colored filter to enhance the natural light emitted.

In a circuit, an LED is connected with forward bias to emit light (Figure 26-15). The forward bias must exceed 1.2 volts before a forward current

FIGURE 26-13

LED construction.

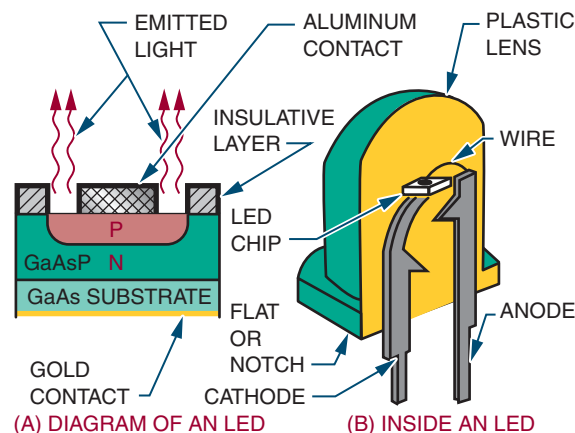


FIGURE 26-14

Common LED packages.



FIGURE 26-15

Forward-biased LED.

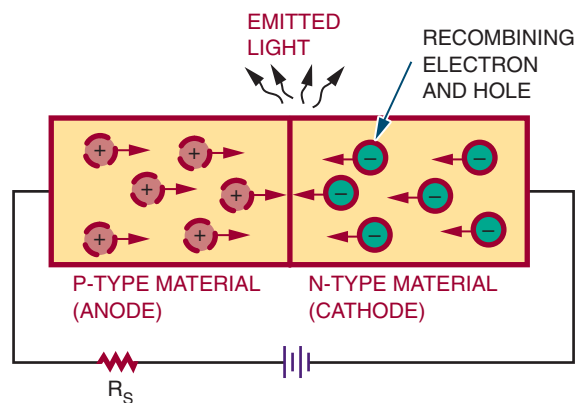


FIGURE 26-16

Schematic symbol for an LED.

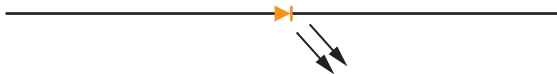
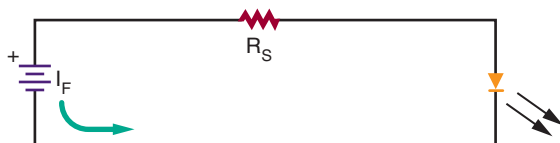


FIGURE 26-17

Properly biased LED circuit.



can flow. Because LEDs can be easily damaged by an excessive amount of voltage or current, a series resistor is connected to limit current flow.

The schematic symbol for an LED is shown in Figure 26-16. Figure 26-17 shows a properly biased circuit. The series resistor (R_s) is used to limit the forward current (I_F) based on the applied voltage.

Figure 26-18 shows LEDs arranged to form a seven-segment display used for digital readouts. Figure 26-19 shows an LED used in conjunction with a phototransistor to form an **optical coupler**. Both devices are housed in the same package. An optical coupler consists of an LED and a phototransistor. They are coupled by the light beam produced by the LED. The signal to the LED can vary, which in turn varies the amount of light available. The phototransistor converts the varying light back into electrical energy. An optical coupler allows one circuit to pass a signal to another circuit while providing a high degree of electrical insulation.

26-3 QUESTIONS

1. Explain how an LED differs from a conventional diode.
2. How does an LED emit different colors of light?

FIGURE 26-18

Seven-segment display of LEDs for digital readout.

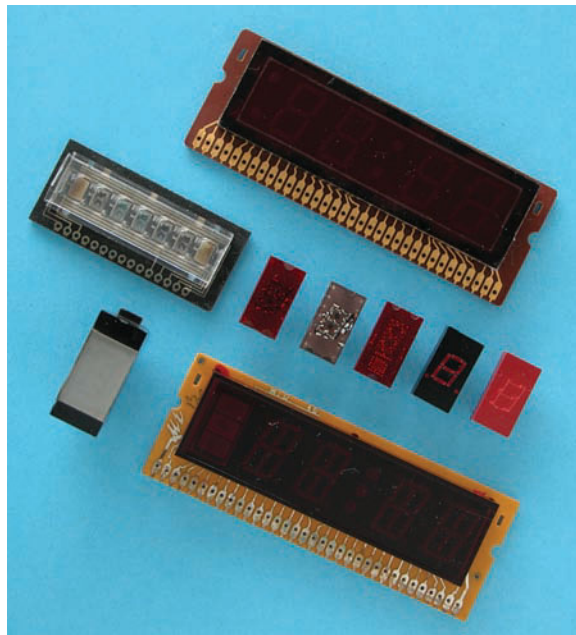
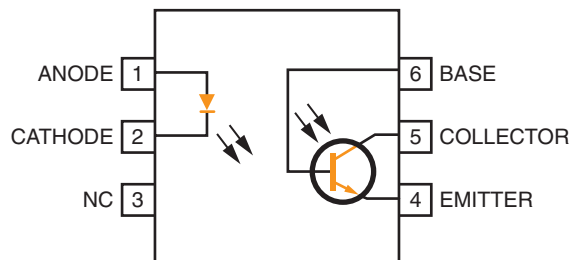


FIGURE 26-19

Commercial optical coupler.



3. How may the LED package enhance the light emitted?
4. Draw and label the schematic symbol for an LED.
5. What is the function of an optical coupler?

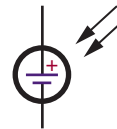
SUMMARY

- Semiconductor devices that interact with light can be classified as light-detection devices, light-conversion devices, or light-emitting devices.
- Light is electromagnetic radiation that is visible to the human eye.
- The frequency range of light is:
 - Infrared light—less than 400,000 gigahertz
 - Visible light—400,000 to 750,000 gigahertz
 - Ultraviolet light—greater than 750,000 gigahertz
- Light-sensitive devices include photo cells, solar cells, photodiodes, and phototransistors.
- Light-emitting devices include the LED (light-emitting diode).
- An optical coupler combines a light-sensitive device with a light-emitting device.
- The schematic symbols for light-sensitive devices are:

Photo cell



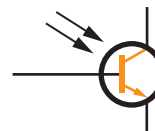
Solar cell



Photodiode



Phototransistor



- The schematic symbol for an LED is:



CHAPTER 26 SELF-TEST

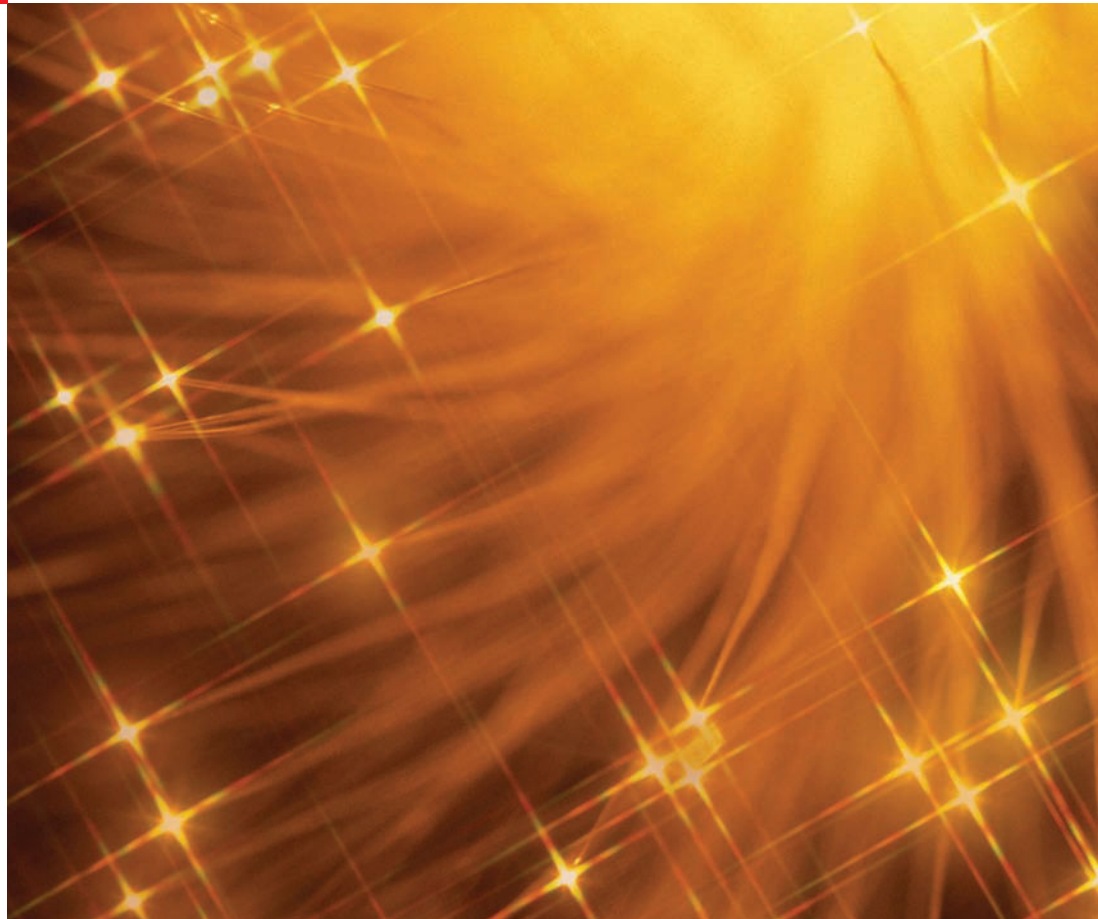
1. Which light-sensitive device has the fastest response time for changes in light intensity?
2. Which light-sensitive device would lend itself to a wider range of applications, a photodiode or a phototransistor? Why?
3. How does the amount of current flowing in an LED affect the intensity of the light emitted?

SECTION 3 ACTIVITY—SEMICONDUCTOR DEVICES

1. Using an assortment of semiconductor devices, identify how to determine if the device is working or defective.
2. Using an assortment of semiconductor devices, look up each item in a catalog and/or on the Internet to determine specifications and price.

SECTION 4

Linear Electronic Circuits



Career Profile

Pablo DeJesus



TITLE

Chief, Strategic Plans Branch for the 46th Test Wing at Eglin Air Force Base, Florida

EMPLOYER

Civil Service Employee—U.S. Air Force (USAF)

BACKGROUND

Pablo graduated with a degree in Electrical Engineering from the University of Puerto Rico, Mayaguez campus, and was hired by the U.S. Air Force (USAF) directly out of college. He started his career as an Electro-optics/Infrared (IR) engineer working for the Test Wing at Eglin Air Force Base where he got to work with some of the latest technologies available in the field of IR sensors and signal processing techniques. During this assignment, Pablo had the opportunity to develop a one-of-a-kind mobile IR data collection system that served the Test Wing mission for more than ten years. After thirteen years in the electro-optics field, Pablo volunteered to transfer into the weapons development division at the Air Armament Center at Eglin Air Force Base, where he served in various positions as both Lead Electronics and Lead General Engineer in support of the development, acquisition, testing, and sustainment of the USAF's air-delivered weapons. After seven years in the weapons development division, Pablo was asked to come back to the Test Wing to serve as chief of strategic planning, which is his current position.

JOB REQUIREMENTS

Electrical Engineering degree

ON THE JOB

As chief of the Strategic Plans Branch, Pablo is responsible for ensuring that the Test Wing is able to support the testing and evaluation of newly developed weapon and command and control (C2) systems. This means that he and his team must stay informed of the latest trends in electronics technologies and how they can be applied to these systems. Pablo must assess where the Test Wing is now and where it needs to be in the near, mid-, and far term in terms of capability to support future testing. Pablo must stay in touch with where the Department of Defense (DoD) wants to go and what the warfighter requirements are in order to plan and smartly invest in future infrastructure and capabilities that will support those future requirements. Pablo also works closely with the Test Wing Commander to ensure that his vision and mission goals are being implemented and match the overall strategy. He has to develop roadmaps, strategic plans, and metrics that guide investments and measure progress.

Pablo also briefs new test engineers and project engineers on the Test Wing capabilities and facilities to familiarize them with the overall mission of the Test Wing, and teaches the Test and Evaluation section of the quarterly Conventional Munitions Orientation Seminar (CMOS).

UPSIDE

The most satisfying part of the job is the opportunity to plan and see investments come to fruition that will enhance the mission of the Test Wing. It also allows Pablo the opportunity to work closely with USAF leaders and better understand their goals and interests. Working with development and research engineers affords Pablo the opportunity to see firsthand some of the future technologies under development and the great possibilities to better support the USAF's mission.

DOWNSIDE

Sometimes it is difficult to understand how newly developed technologies will be applied to a weapon or a command and control system, and from there how and what needs to be done in order to be able to test that capability at some point in the future. Occasionally you have to just make an "educated guess," which sometimes leads to success and sometimes doesn't.

OPPORTUNITIES

There are many civil service opportunities for electrical/electronics engineers supporting the military. The military uses all of the latest technologies. Command, control, and communication is a big field in the Department of Defense and it is a field that requires electrical/electronics engineers and technicians. As the military moves into a network-centric warfare environment there will be an ever-increasing number of new and exiting challenges for engineers and technicians in the field of electronics.

WORDS OF ADVICE

Develop a solid base of skills in the field of electronics in school. Then find work in a related field to gain valuable experience. Once you have both education and experience, consider branching out to broaden your career by working in some other related fields. Always stay engaged and up-to-date with trends in the field.

Power Supplies

OBJECTIVES

After completing this chapter, the student should be able to:

- Explain the purpose of a power supply.
- Draw a block diagram of the circuits and parts of a power supply.
- Describe the three different rectifier configurations.
- Explain the function of a filter.
- Describe the two basic types of voltage regulators and how they operate.
- Explain the function of a voltage multiplier.
- Identify over-voltage and over-current protection devices.

Power supplies are used to supply voltage to a variety of circuits. Their basic principles are the same.

The primary function of the power supply is to convert alternating current (AC) to direct current (DC). The power supply may increase or decrease the incoming AC voltage by means of a transformer.

Once the voltage is at the desired level, it is converted to a DC voltage through a process called rectification. The rectified voltage still contains an AC signal, which is referred to as a ripple frequency. The ripple is removed with a filter.

To ensure that the output voltage remains at a constant level, a voltage regulator is used. The voltage regulator holds the output voltage at a constant level.



See accompanying CD for Power Supply examples in MultiSim, Chapter 27.

27-1 TRANSFORMERS

Transformers are used in power supplies to isolate the power supply from the AC voltage source. They are also used to step up voltages if higher voltages are required or to step down voltages if lower voltages are required.

If transformers are used in power supplies, the AC power source is connected only to the primary of the transformer. This isolates the electrical circuits from the power source.

When selecting a transformer, its primary power rating is the first concern. The most common primary ratings are 110 to 120 volts and 220 to 240 volts. The next concern is its frequency. Some frequencies are 50 to 60 hertz, 400 hertz, and 10,000 hertz. The third concern is its secondary voltage and current ratings. The final concern is its power-handling capability, or volt-ampere rating. This is essentially the amount of power that can be delivered to the secondary of the transformer. It is given as volt-amperes because of the loads that can be placed on the secondary.

27-1 QUESTIONS

1. Why are transformers used in power supplies?
2. How is a transformer connected in a power supply?
3. What are the important considerations when selecting a transformer for a power supply?
4. How are transformers rated?

27-2 RECTIFIER CIRCUITS

The **rectifier circuit** is the heart of the power supply. Its function is to convert the incoming AC voltage to a DC voltage. There are three basic

FIGURE 27-1

Basic half-wave rectifier.

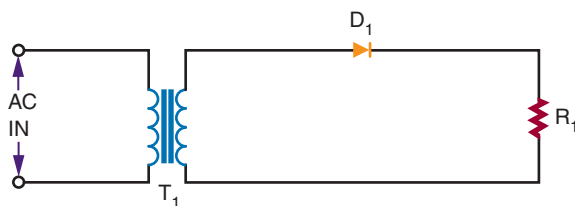
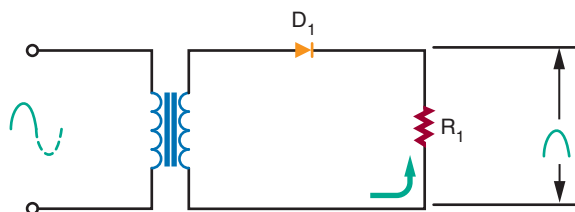


FIGURE 27-2

Half-wave rectifier during positive alternation.



types of rectifier circuit used with power supplies: **half-wave rectifiers**, **full-wave rectifiers**, and **bridge rectifiers**.

Figure 27-1 shows a basic half-wave rectifier. The diode is located in series with the load. The current in the circuit flows in only one direction because of the diode.

Figure 27-2 shows a half-wave rectifier during the positive alternation of the sine wave. The diode is forward biased, allowing a current to flow through the load. This allows the positive alternation of the cycle to develop across the load.

Figure 27-3 shows the circuit during the negative alternation of the sine wave. The diode is now reverse biased and does not conduct. Because no current flows through the load, no voltage is dropped across the load.

The half-wave rectifier operates during only one-half of the input cycle. The output is a series of positive or negative pulses, depending on how the diode is connected in the circuit. The frequency of the pulses is the same as the input fre-

FIGURE 27-3
Half-wave rectifier during negative alternation.

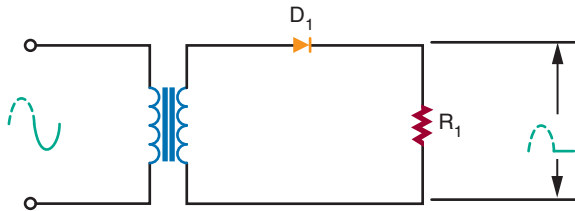
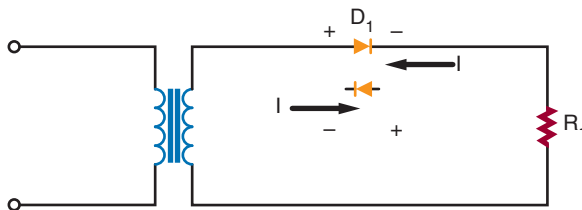


FIGURE 27-4
The diode determines the direction of current flow.



quency. The frequency of the pulses is called the *ripple frequency*.

The polarity of the output depends on which way the diode is connected in the circuit (Figure 27-4). The current flows through the diode from cathode to anode. When current flows through a diode, a deficiency of electrons exists at the anode end, making it the positive end of the diode. The polarity of the power supply can be reversed by reversing the diode.

There is a serious disadvantage with the half-wave rectifier because current flows during only half of each cycle. To overcome this disadvantage, a full-wave rectifier can be used.

Figure 27-5 shows a basic full-wave rectifier circuit. It requires two diodes and a center-tapped transformer. The center tap is grounded. The voltages at each end of the transformer are 180 degrees out of phase with each other.

Figure 27-6 shows a full-wave rectifier during the positive alternation of the input signal. The anode of diode D_1 is positive, and the anode of

FIGURE 27-5
Basic full-wave rectifier circuit.

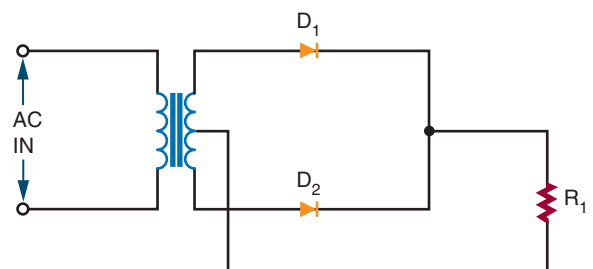
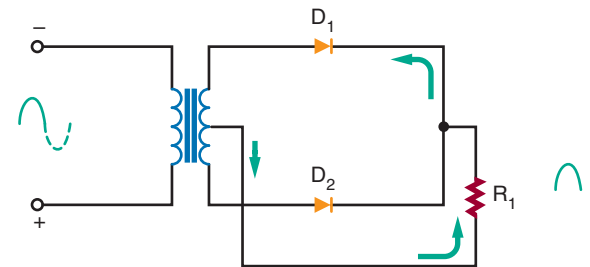


FIGURE 27-6
Full-wave rectifier during positive alternation.



of diode D_2 is negative. Diode D_1 is forward biased and conducts current. Diode D_2 is reverse biased and does not conduct. The current flows from the center tap of the transformer through the load and diode D_1 , to the top of the secondary of the transformer. This permits the positive half of the cycle to be felt across the load.

Figure 27-7 shows the full-wave rectifier during the negative half of the cycle. The anode of diode D_2 becomes positive, and the anode of diode D_1 becomes negative. Diode D_2 is now forward biased and conducts. Diode D_1 is reverse biased and does not conduct. The current flows from the center tap of the transformer through the load and diode D_2 to the bottom of the secondary of the transformer.

With a full-wave rectifier, the current flows during both half-cycles. This means that the ripple frequency is twice the input frequency.

FIGURE 27-7

Full-wave rectifier during negative alternation.

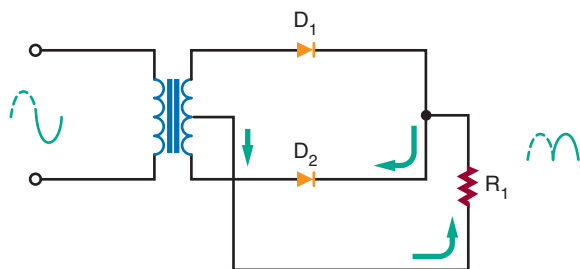
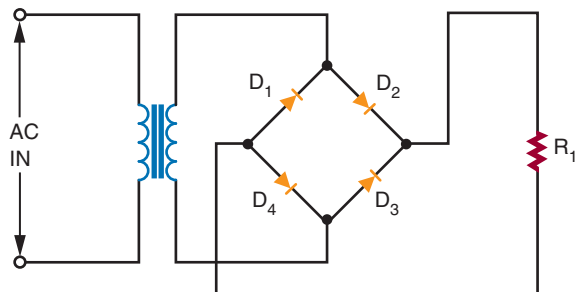


FIGURE 27-8

Bridge rectifier circuit.



There is a disadvantage with the full-wave rectifier because the output voltage is half that of a half-wave rectifier for the same transformer. This disadvantage can be overcome by the use of a bridge rectifier circuit.

Figure 27-8 shows a bridge rectifier circuit. The four diodes are arranged so that the current flows in only one direction through the load.

Figure 27-9 shows the current flow during the positive alternation of the input signal. Current flows from the bottom of the secondary side of the transformer, up through diode D_4 , through the load, through diode D_2 to the top of the secondary of the transformer. The entire voltage is dropped across the load.

Figure 27-10 shows the current flow during the negative alternation of the input signal. The top of the secondary is negative, and the bottom

FIGURE 27-9

Bridge rectifier during positive alternation.

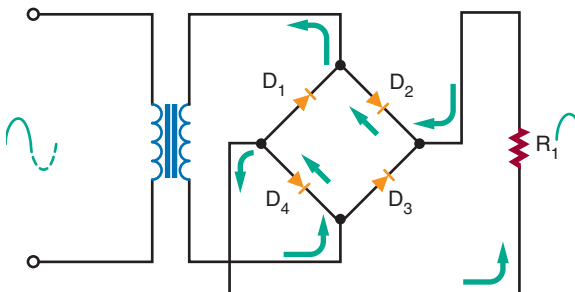
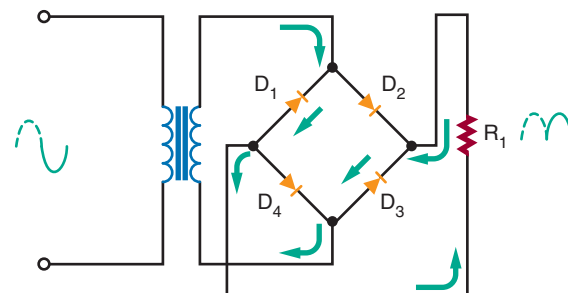


FIGURE 27-10

Bridge rectifier during negative alternation.



is positive. The current flows from the top of the secondary, down through diode D_1 , through the load and diode D_3 to the bottom of the secondary. Note that the current flows in the same direction through the load as during the positive alternation. Again the entire voltage is dropped across the load.

A bridge rectifier is a type of full-wave rectifier because it operates on both half-cycles of the input sine wave. The advantage of the bridge rectifier is that the circuit does not require a center-tapped secondary. This circuit does not require a transformer to operate. A transformer is used only to step up or step down the voltage or provide isolation.

To summarize the differences in rectifiers: The advantages of the half-wave rectifier are its sim-

plicity and low cost. It requires one diode and a transformer. It is not very efficient, because only half of the input signal is used. It is also restricted to low-current applications.

The full-wave rectifier is more efficient than the half-wave rectifier. It operates on both alternations of the sine wave. The higher ripple frequency of the full-wave rectifier is easier to filter. A disadvantage is that it requires a center-tapped transformer. Its output voltage is lower than that of a half-wave rectifier for the same transformer because of the center tap.

The bridge rectifier can operate without a transformer. However, a transformer is needed to step up or step down the voltage. The output of the bridge rectifier is higher than that of either the full-wave or half-wave rectifier. A disadvantage is that the bridge rectifier requires four diodes. However, the diodes are inexpensive compared to a center-tapped transformer.

27-2 QUESTIONS

1. What is the function of the rectifier in a power supply?
2. What are three configurations for connecting rectifiers to power supplies?
3. What are the differences in operation of the three configurations?
4. What are the advantages of one rectifier configuration over another?
5. Which rectifier configuration represents the best selection? Why?

27-3 FILTER CIRCUITS

The output of the rectifier circuit is a pulsating DC voltage. This is not suitable for most electronic circuits. Therefore, a filter follows the rectifier in most power supplies. The **filter** converts the pulsating DC voltage to a smooth DC voltage.

FIGURE 27-11
Half-wave rectifier with capacitor filter.

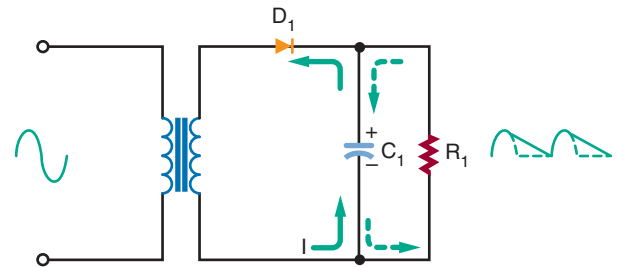
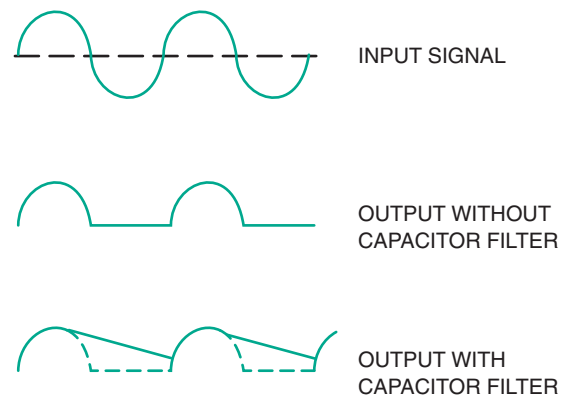


FIGURE 27-12
Output of a half-wave rectifier without and with a filter capacitor.



The simplest filter is a capacitor connected across the output of the rectifier (Figure 27-11). Figure 27-12 compares the outputs of a rectifier without and with the addition of a filter capacitor.

A capacitor affects the circuit in the following manner. When the anode of the diode is positive, current flows in the circuit. At the same time, the filter capacitor charges to the polarity indicated in Figure 27-11. After 90 degrees of the input signal, the capacitor is fully charged to the peak potential of the circuit.

When the input signal starts to drop in the negative direction, the capacitor discharges through the load. The resistance of the load controls the rate

the capacitor discharges by the RC time constant. The discharge time constant is long compared to the cycle time. Therefore the cycle is completed before the capacitor can discharge. Thus, after the first quarter cycle, the current through the load is supplied by the discharging capacitor. As the capacitor discharges, the voltage stored in the capacitor decreases. However, before the capacitor can completely discharge, the next cycle of the sine wave occurs. This causes the anode of the diode to become positive, allowing the diode to conduct. The capacitor recharges and the cycle repeats. The end result is that the pulses are smoothed out and the output voltage is actually raised (Figure 27–13).

The larger the capacitor, the greater (longer) the RC time constant. This results in a slower discharge of the capacitor, raising the output voltage. The presence of the capacitor allows the diode in the circuit to conduct for a shorter period of time. When the diode is not conducting, the capacitor is supplying the current to the load. If the current required by the load is large, a very large capacitor must be used.

A capacitor filter across a full-wave or bridge rectifier behaves much like the capacitor filter in the half-wave rectifier just described. Figure 27–14 shows the output of a full-wave or bridge rectifier. The ripple frequency is twice that of the half-wave rectifier. When the capacitor filter is added to the output of the rectifier, the capacitor does not discharge very far before the next pulse occurs. The output voltage is high. If a large capacitor is used, the output equals the peak voltage of the input signal. Thus, the capacitor does a better job of filtering in a full-wave circuit than in a half-wave circuit.

The purpose of the filter capacitor is to smooth out the pulsating DC voltage from the rectifier. The filter's performance is determined by the ripple remaining on the DC voltage. The ripple can be made lower by using a large capacitor or by increasing the load resistance. Typically, the load resistance is determined by the circuit design. Therefore, the size of the filter capacitor is determined by the amount of the ripple.

It should be realized that the filter capacitor places additional stress on the diodes used in the rectifier circuit. A half-wave and a full-wave rec-

FIGURE 27–13

Effects of different filter capacitors on output of half-wave rectifier.

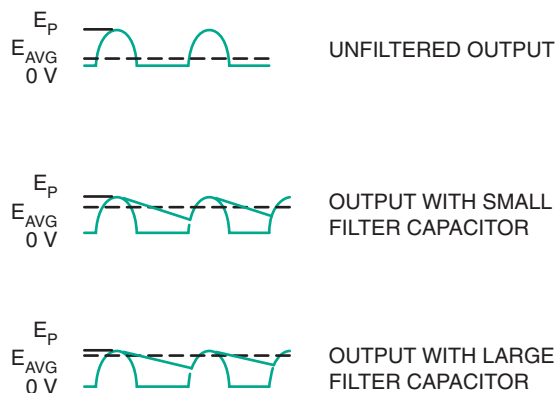


FIGURE 27–14

Effects of different filter capacitors on output of full-wave or bridge rectifier.

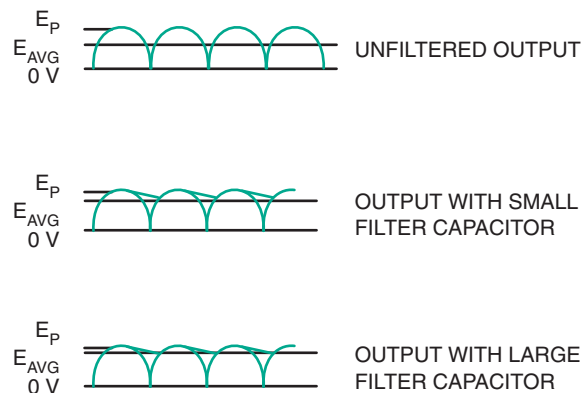
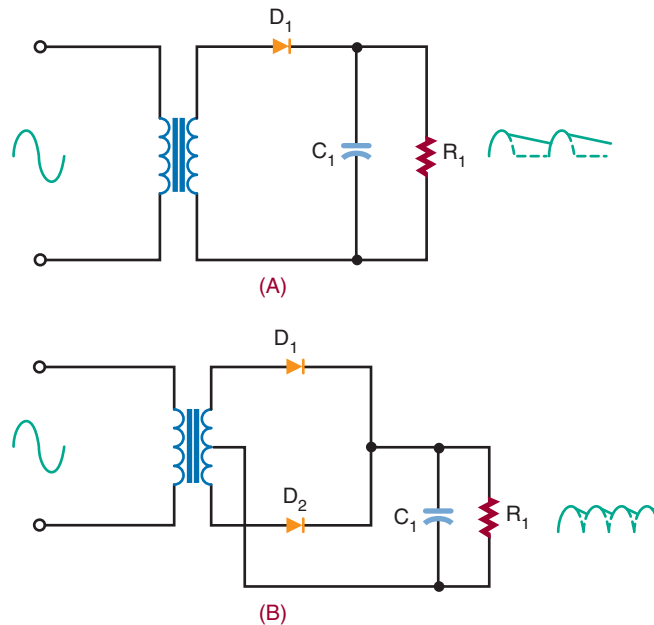


FIGURE 27-15

Half-wave rectifier (A) and full-wave rectifier (B) followed by a filter capacitor.

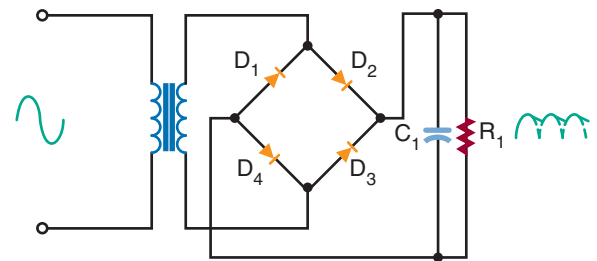


tifier followed by a filter capacitor are shown in Figure 27-15. The capacitor charges to the peak value of the secondary voltage and holds this value throughout the input cycle. When the diode becomes reverse biased, it shuts off and a maximum negative voltage is felt on the anode of the diode. The filter capacitor holds a maximum positive voltage on the cathode of the diode. The difference of potential across the diode is twice the peak value of the secondary. The diode must be selected to withstand this voltage.

The maximum voltage a diode can withstand when reverse biased is called the *peak-inverse-voltage (PIV)*. A diode should be selected that has a PIV higher than twice the peak value. Ideally, the diode should be operated at 80% of its rated value to allow for changes in the input voltage. This holds true for both the half-wave and the full-wave rectifier. This does not hold true for the bridge rectifier.

FIGURE 27-16

Bridge rectifier with capacitor filter.



The diodes in a bridge rectifier are never exposed to more than the peak value of the secondary. In Figure 27-16, none of the diodes is exposed to more than the peak value of the input signal. The use of diodes with lower PIV ratings represents another advantage of the bridge rectifier.

27-3 QUESTIONS

1. What is the purpose of a filter in a power supply?
2. What is the simplest filter configuration?
3. What is the ripple frequency?
4. How is a filter capacitor selected?
5. What adverse effects result from the addition of a filter?

27-4 VOLTAGE REGULATORS

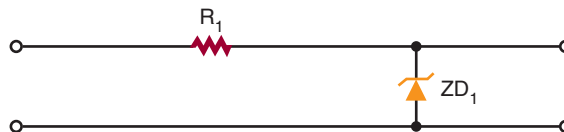
Two factors can cause the output voltage of a power supply to vary. First, the input voltage to the power supply can vary, resulting in increases and decreases in the output voltage. Second, the load resistance can vary, resulting in a change in current demand.

Many circuits are designed to operate at a certain voltage. If the voltage varies, the operation of the circuit is affected. Therefore, the power supply must produce the same output regardless of load and input voltage changes. To accomplish this, a **voltage regulator** is added after the filter.

There are two basic types of voltage regulators: **shunt regulators** and **series regulators**. They are named for the method by which they are connected with the load. The shunt regulator is connected in parallel with the load. The series regulator is connected in series with the load. Series regulators are more popular than shunt regulators because they are more efficient and dissipate less power. The shunt regulator also acts as a control device, protecting the regulator from a short in the load.

Figure 27-17 shows a basic zener diode regulator circuit. This is a shunt regulator. The zener diode is connected in series with a resistor. The input voltage, unregulated DC voltage, is applied across both the zener diode and the

FIGURE 27-17
Basic zener diode regulator circuit.



resistor so as to make the zener diode reverse biased. The resistor allows a small current to flow to keep the zener diode in its zener breakdown region. The input voltage must be higher than the zener breakdown voltage of the diode. The voltage across the zener diode is equal to the zener diode's voltage rating. The voltage dropped across the resistor is equal to the difference between the zener diode's voltage and the input voltage.

The circuit shown in Figure 27-17 provides a constant output voltage for a changing input voltage. Any change in the voltage appears across the resistor. The sum of the voltage drops must equal the input voltage. By changing the output zener diode and the series resistor, the output voltage can be increased or decreased.

The current through the load is determined by the load resistance and the output voltage. The load current and the zener current flow through the series resistor. The series resistor must be chosen carefully so that the zener current keeps the zener diode in the breakdown zone and allows the current to flow.

When the load current increases, the zener current decreases and the load current and zener current together maintain a constant voltage. This allows the circuit to regulate for changes in output current as well as input voltage.

Figure 27-18 shows a shunt regulator circuit using a transistor. Note that transistor Q_1 is in parallel with the load. This protects the regulator in case a short develops with the load. More complex shunt regulators are available that use more than one transistor.

FIGURE 27-18

Shunt regulator using a transistor.

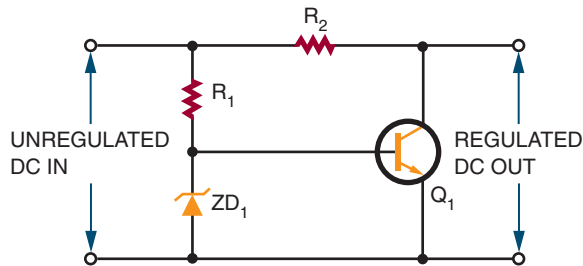
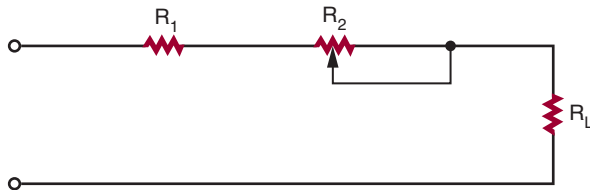


FIGURE 27-19

Series regulator using a variable resistor.



The series regulator is more popular than the shunt regulator. The simplest series regulator is a variable resistor in series with the load (Figure 27-19). The resistance is adjusted continuously to maintain a constant voltage across the load. When the DC voltage increases, the resistance increases, dropping more voltage. This maintains the voltage drop across the load by dropping the extra voltage across the series resistor.

The variable resistor can also compensate for changes in load current. If the load current increases, more voltage drops across the variable resistor. This results in less voltage dropped across the load. If the resistance can be made to decrease at the same instant that the current increases, the voltage dropped across the variable resistor can remain constant. This results in a constant output voltage despite changes in the load current.

In reality, it is too difficult to vary the resistance manually to compensate for voltage and current changes. It is more efficient to replace the variable resistor with a transistor (Figure 27-20). The transistor is connected so that the load's cur-

FIGURE 27-20

Transistor series regulator using a manually adjusted variable resistor.

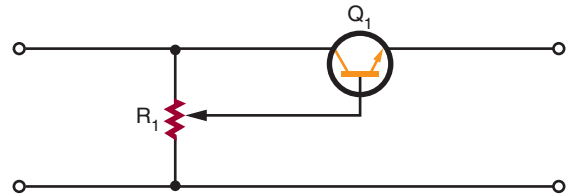
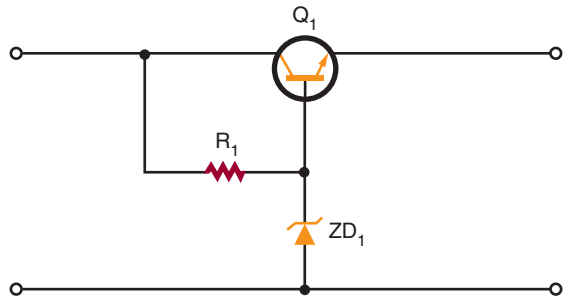


FIGURE 27-21

Self-adjusting series regulator.

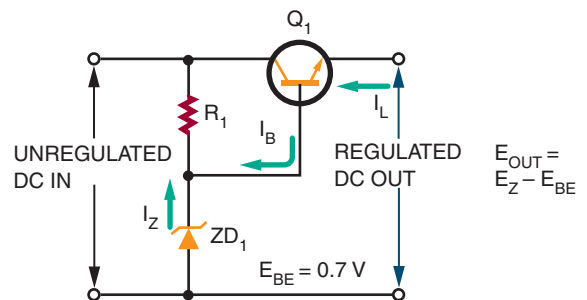


rent flows through it. By changing the current on the base of the transistor, the transistor can be biased to conduct more or less current. Additional components are required to make the circuit self-adjusting (Figure 27-21). These components allow the transistor to compensate automatically for changes in the input voltage or load current.

Figure 27-22 shows a simple series regulator. The input is unregulated DC voltage, and the

FIGURE 27-22

A series regulator.



output is in a lower, regulated DC voltage. The transistor is connected as an emitter follower, meaning that there is a lack of phase inversion between the base and the emitter. The emitter voltage follows the base voltage. The load is connected between the emitter of the transistor and ground. The voltage at the base of the transistor is set by the zener diode. Therefore, the output voltage is equal to the zener voltage minus the 0.7 volt dropped across the base-emitter junction of the transistor.

When the input voltage increases through the transistor, the voltage out also tries to increase. The base voltage is set by the zener diode. If the emitter becomes more positive than the base, the conductance of the transistor decreases. When the transistor conducts less, it reacts the same way a large resistor would react if placed between the input and output. Most of the increase in input voltage is dropped across the transistor and there is only a small increase in the output voltage.

There is a disadvantage with the emitter-follower regulator because the zener diode must have a large power rating. Zener diodes with large power-handling capabilities are expensive.

A more popular type of series regulator is the feedback regulator. A feedback regulator consists of a feedback circuit to monitor the output voltage. If the output voltage changes, a control signal is developed. This signal controls the transistor's conductance. Figure 27–23 shows a block diagram of the feedback regulator. An unregulated DC voltage is applied to the input of the regulator. A lower, regulated DC output voltage appears at the output terminals of the regulator.

A sampling circuit appears across the output terminals. A *sampling circuit* is a voltage divider that sends a sample of the output voltage to the error-detection circuit. The voltage changes if the output voltage changes.

The error-detection circuit compares the sampled voltage with a reference voltage. In order to produce the reference voltage, a zener

diode is used. The difference between the sample and reference voltages is the *error voltage*. The error voltage is amplified by an error amplifier. The error amplifier controls the conduction of the series transistor. The transistor conducts more or less to compensate for changes in the output voltage.

Figure 27–24 shows a feedback voltage regulator circuit. Resistors R_3 , R_4 , and R_5 form the sampling circuit. Transistor Q_2 acts as both the error-detection and error-amplification circuit. Zener diode D_1 and resistor R_1 produce the reference voltage. Transistor Q_1 is the series regulator transistor. Resistor R_2 is the collector load resistor for transistor Q_2 and the biasing resistor for transistor Q_1 .

If the output voltage tries to increase, the sample voltage also increases. This increases the bias voltage on the base of transistor Q_2 . The emitter voltage of transistor Q_2 is held constant by zener diode D_1 . This results in transistor Q_2 conducting more and increasing the current through resistor R_2 . In turn, the voltage on the collector of transistor Q_2 and the base of transistor Q_1 decreases. This decreases the forward bias of transistor Q_1 , causing it to conduct less. When transistor Q_1 conducts less, less current flows. This causes a smaller voltage drop across the load and cancels the increase in voltage.

The output voltage can be adjusted accurately by varying potentiometer R_4 . To increase the output voltage of the regulator, the wiper of potentiometer R_4 is moved in the more negative direction. This decreases the sample voltage on the base of transistor Q_2 , decreasing the forward bias. This results in transistor Q_2 conducting less, causing the collector voltage of transistor Q_2 and base of transistor Q_1 to increase. This increases the forward bias on transistor Q_1 , causing it to conduct more. More current flows through the load, which increases the voltage out.

There is a serious disadvantage with the series regulator because the transistor is in series with

FIGURE 27–23

Block diagram of a feedback series regulator.

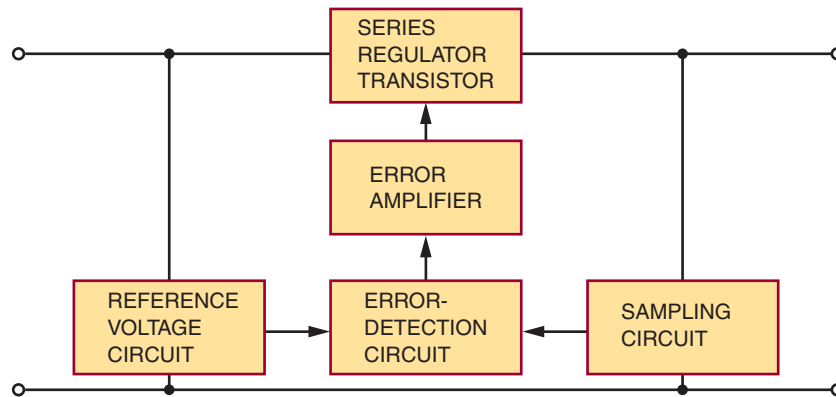


FIGURE 27–24

Basic feedback series regulator.

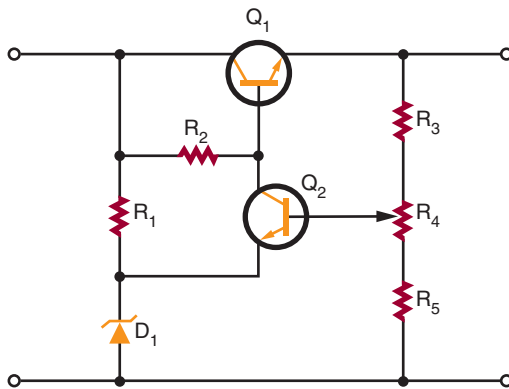
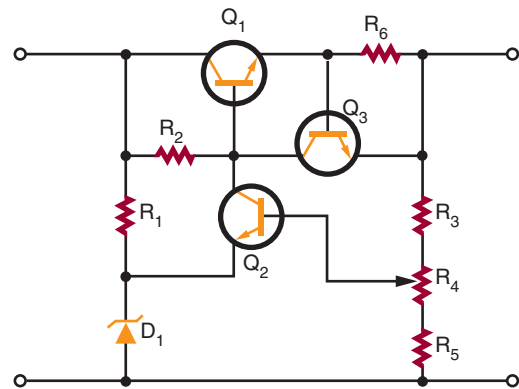


FIGURE 27–25

Feedback series regulator with current-limiting circuit.



the load. A short in the load would result in a large current flowing through the transistor, which could destroy the transistor. A circuit is needed to keep the current passing through the transistor at a safe level.

Figure 27–25 shows a circuit that limits current through the series regulator transistor. It is shown added to the feedback series voltage regulator. Transistor Q_3 and resistor R_6 form the current-limiting circuit. In order for transistor Q_3 to conduct, the base-to-emitter junction must be

forward biased by a minimum of 0.7 volt. When 0.7 volt is applied between the base and emitter, the transistor conducts. If R_6 is 1 ohm, the current necessary to develop 0.7 volt to the base of transistor Q_3 is:

$$I = \frac{E}{R}$$

$$I = \frac{0.7}{1}$$

$$I = 0.7 \text{ A or } 700 \text{ mA}$$

When less than 700 milliamperes of current flows, transistor Q_3 's base-to-emitter voltage is less than 0.7 volt, keeping it shut off. When transistor Q_3 is shut off, the circuit acts as if it does not exist. When the current exceeds 700 milliamperes, the voltage dropped across resistor R_6 increases above 0.7 volt. This results in transistor Q_3 conducting through resistor R_2 . This decreases the voltage on the base of transistor Q_1 , causing it to conduct less. The current cannot increase above 700 milliamperes. The amount of current that can be limited can be varied by changing the value of resistor R_6 . Increasing the value of resistor R_6 lowers the limit on current value.

The feedback series regulator has another disadvantage, the number of components required. This problem can be overcome by the use of an integrated circuit (IC) regulator.

Modern IC regulators are low in cost and easy to use. Most IC regulators have only three terminals (input, output, and ground) and can be connected directly to the filtered output of a rectifier (Figure 27–26). The IC regulator provides a wide variety of output voltages of both positive and negative polarities. If a voltage is needed that is not a standard voltage, adjustable IC regulators are available.

In selecting an IC regulator, the voltage and load current requirements must be known along

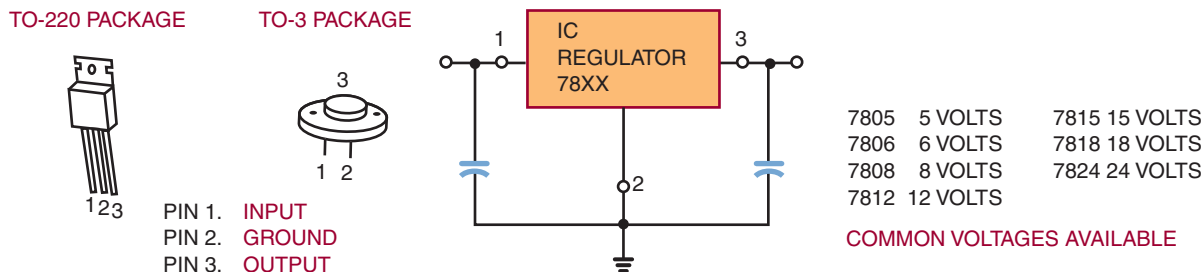
with the electrical characteristics of the unregulated power supply. IC regulators are classified by their output voltage. Fixed voltage regulators have three terminals and provide only one output voltage. They are available in both positive and negative voltages. Dual-polarity voltage regulators can supply both a positive and a negative voltage. Both fixed- and dual-polarity voltage regulators are available as adjustable voltage regulators. If using any of the IC voltage regulators, refer to the manufacturer's specification sheet.

27-4 QUESTIONS

1. What is the purpose of a voltage regulator in a power supply?
2. What are the two basic types of voltage regulators?
3. Which type of voltage regulator is used more?
4. Draw a schematic of a simple zener diode voltage regulator and explain how it operates.
5. Draw a block diagram of a series feedback regulator and explain how it operates.

FIGURE 27-26

Three-terminal IC regulator.



27-5 VOLTAGE MULTIPLIERS

In all previous cases, the DC voltage is limited to the peak value of the input sine wave. When higher DC voltages are required, a step-up transformer is used. However, higher DC voltages can be produced without a step-up transformer. Circuits that are capable of producing higher DC voltages without the benefit of a transformer are called **voltage multipliers**. Two voltage multipliers are the **voltage doubler** and the **voltage tripler**.

Figure 27-27 shows a half-wave voltage doubler. It produces a DC output voltage that is twice the peak value of the input signal. Figure 27-28 shows the circuit during the negative alternation of the input signal. Diode D_1 conducts, and the current flows along the path shown. Capacitor C_1 charges to the peak value of the input signal. Be-

FIGURE 27-27
Half-wave voltage doubler.

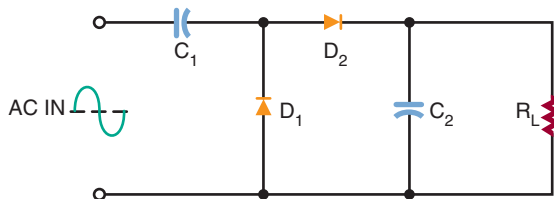


FIGURE 27-28
Half-wave voltage doubler during negative alternation of input signal.

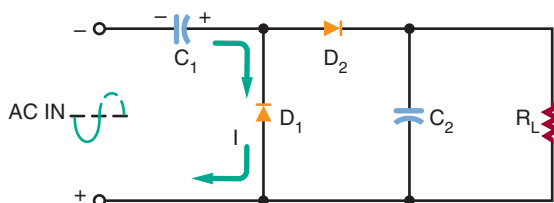
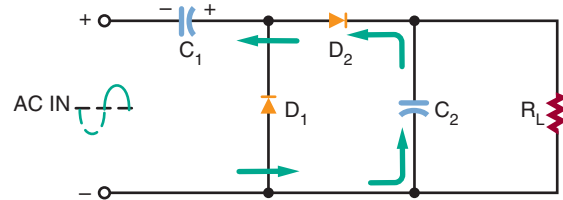


FIGURE 27-29
Half-wave voltage doubler during positive alternation of input signal.



cause there is no discharge path, capacitor C_1 remains charged. Figure 27-29 shows the positive alternation of the input signal. At this point, capacitor C_1 is charged to the negative peak value. This keeps diode D_1 reverse biased and forward biases diode D_2 . This allows diode D_2 to conduct, charging capacitor C_2 . Because capacitor C_1 is charged to the maximum negative value, capacitor C_2 charges to twice the peak value of the input signal.

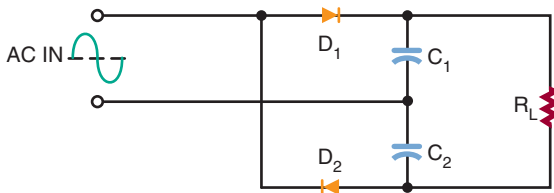
As the sine wave changes from the positive half cycle to the negative half cycle, diode D_2 is cut off. This is because capacitor C_2 holds diode D_2 reverse biased. Capacitor C_2 discharges through the load, holding the voltage across the load constant. Therefore, it also acts as a filter capacitor.

Capacitor C_2 recharges only during the positive cycle of the input signal, resulting in a ripple frequency of 60 hertz (hence the name half-wave voltage doubler). One disadvantage of the half-wave voltage doubler is its hard to filter because of the 60-hertz ripple frequency. Another disadvantage is that capacitor C_2 must have a voltage rating of at least twice the peak value of the AC input signal.

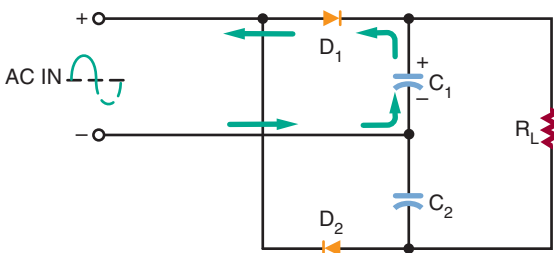
A full-wave voltage doubler overcomes some of the disadvantages of the half-wave voltage doubler. Figure 27-30 is a schematic of a circuit that operates as a full-wave voltage doubler. Figure 27-31 shows that, on the positive alternation

FIGURE 27-30

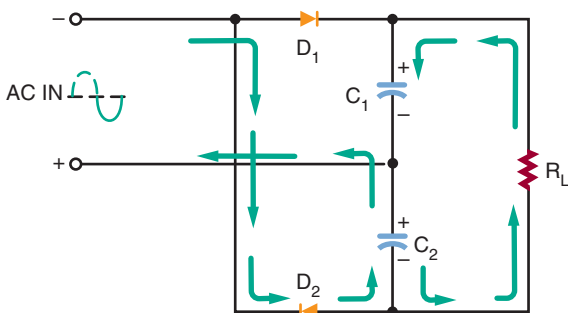
Full-wave voltage doubler.

**FIGURE 27-31**

Full-wave voltage doubler during positive alternation of input signal.

**FIGURE 27-32**

Full-wave voltage doubler during negative alternation of input signal.



of the input signal, capacitor C_1 charges through diode D_1 to the peak value of the AC input signal. Figure 27-32 shows that, on the negative alternation, capacitor C_2 charges through diode D_2 to the peak value of the input signal.

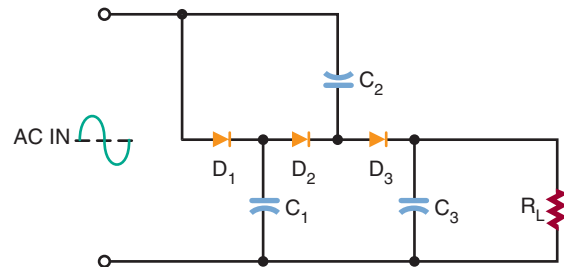
When the AC input signal is changing between the peaks of the alternations, capacitors C_1 and C_2 discharge in series through the load. Because each capacitor is charged to the peak value of the input signal, the total voltage across the load is two times the peak value of the input signal.

Capacitors C_1 and C_2 are charged during the peaks of the input signal. The ripple frequency is 120 hertz because both capacitors C_1 and C_2 are charged during each cycle. Capacitors C_1 and C_2 split the output voltage to the load, so each capacitor is subject to the peak value of the input signal.

Figure 27-33 shows the circuit of a voltage tripler. In Figure 27-34, the positive alternation of the input signal biases diode D_1 so that it conducts. This charges capacitor C_1 to the peak value of the

FIGURE 27-33

Voltage tripler.

**FIGURE 27-34**

Voltage tripler during first positive alternation of input signal.

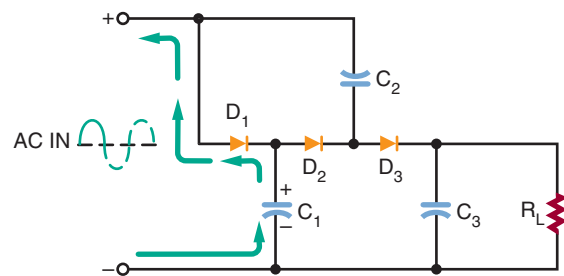


FIGURE 27-35

Voltage tripler during negative alternation of input signal.

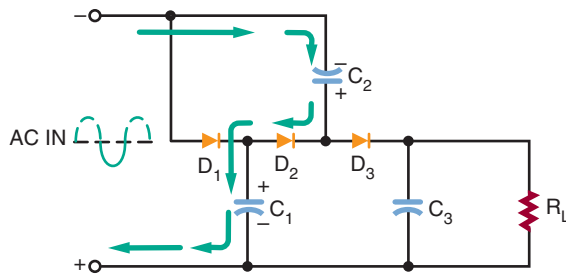
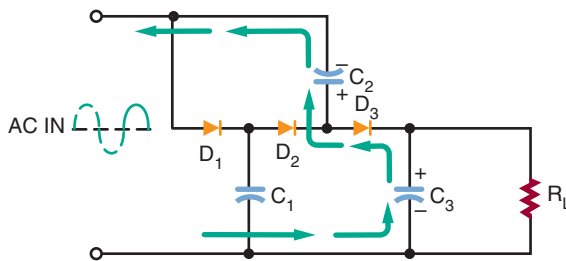


FIGURE 27-36

Voltage tripler during second positive alternation of input signal.



input signal. Capacitor C_1 places a positive potential across diode D_2 .

Figure 27-35 shows the negative alternation of the input signal. Because diode D_2 is now forward biased, current flows through it to capacitor C_1 via capacitor C_2 . This charges capacitor C_2 to twice the peak value because of the voltage stored in capacitor C_1 .

Figure 27-36 shows the occurrence of the next positive alternation. It places a difference of potential across capacitor C_2 that is three times the peak value. The top plate of capacitor C_2 has a positive peak value of two times the peak value. The anode of diode D_3 has a positive value of three times the peak value with respect to ground. This charges capacitor C_3 to three times the peak value. This is the voltage that is applied to the load.

27-5 QUESTIONS

1. What is the function of a voltage multiplier circuit?
2. Draw a schematic of a half-wave voltage doubler and explain how it operates.
3. Draw a schematic of a full-wave voltage doubler.
4. Draw a schematic of a voltage tripler.
5. What requirement must be placed on capacitors used in voltage doubler and tripler circuits?

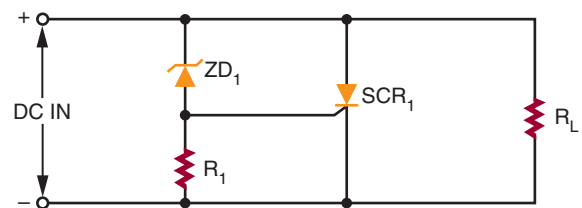
27-6 CIRCUIT-PROTECTION DEVICES

To protect the load from failure of the power supply, an **over-voltage protection circuit** is used.

Figure 27-37 shows an over-voltage protection circuit called a *crowbar*. The SCR, placed in parallel with the load, is normally cut off (not conducting). If the output voltage rises above a predetermined level, the SCR turns on and places a short circuit across the load. With the short circuit across the load, very little current flows through the load. This fully protects the load. The short circuit across the load does not protect the power supply. The output of the power supply is shorted, thereby blowing the fuse of the power supply.

FIGURE 27-37

Crowbar overprotection circuit.



The zener diode establishes the voltage level at which the SCR turns on. It protects the load from voltage above the zener voltage. As long as the supply voltage is less than the zener diode voltage rating, the diode does not conduct. This keeps the SCR turned off.

If the supply voltage rises above the zener voltage due to a malfunction, the zener diode conducts. This creates a gate current to the SCR, turning it on and shorting out the load. It should be noted that the SCR must be large enough to handle the large short-circuit current.

To protect circuits against excessive transient voltage, a varistor is used. A varistor is an electronic component and the most common type is a Metal Oxide Varistor (MOV). An MOV protects various types of electronic devices and semiconductor elements from switching and induced lightning surges. When exposed to high transient voltage, the MOV clamps the voltage to a safe level. An MOV absorbs potentially destructive energy and dissipates it as heat, protecting the circuit components.

MOV devices are made primarily of zinc oxide with small amounts of bismuth, cobalt, manganese, and other metal oxides. They can be connected in parallel for increased energy-handling capabilities. They can also be connected in series to provide higher voltage ratings or to provide voltage rating between the standard increments.

MOVs are available with peak current ratings ranging from 40A to 70,000A.

Another protection device is a **fuse** (Figure 27–38). A fuse is a device that fails when an overload occurs. A fuse is essentially a small piece of wire between two metal terminals. A hollow glass cylinder holds the metal terminals apart and protects the wire. Typically, a fuse is placed in series with the primary of the power supply transformer. If a large current flows in the power supply, it causes the fuse wire to overheat and melt. This opens the circuit so that no more current can

FIGURE 27–38

Fuses used for protection of electronic circuits.



flow. The glass housing of the fuse allows a visual check to see if the fuse is blown.

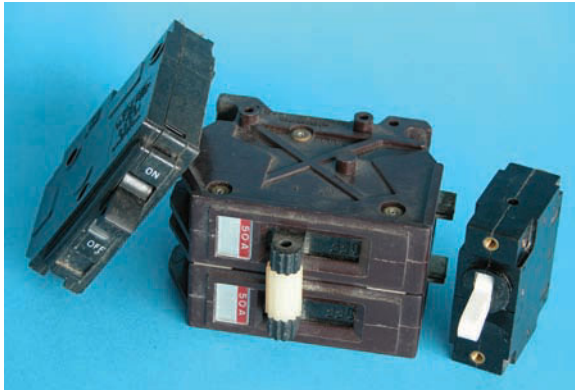
Fuses are classified as normal or slow blow. A *normal* fuse opens as soon as its current is exceeded. In some circuits this is an advantage because it removes the overload very quickly. A *slow-blow* fuse can withstand a brief period of overloading before it blows. This brief period of overloading occurs because the fuse wire heats more slowly. If the overload is present for longer than a few seconds, it blows the fuse. A slow-blow fuse may contain a spring for pulling the fuse wire apart once it melts. Some circuits can withstand a surge in current. In these, a slow-blow fuse is preferable to a normal fuse.

The fuse is always installed after the switch on the hot (live and energized) lead of the AC power source. This disconnects the transformer from the AC power source when the fuse blows. By installing it after the switch, power can be removed from the fuse holder for added safety in replacing a blown fuse.

WARNING: A blown fuse should not be replaced until the fault is diagnosed and corrected.

FIGURE 27-39

Circuit breakers used for protection of electronic circuits.



A disadvantage of the fuse is that it must be replaced each time it blows. A **circuit breaker** performs the same job but does not have to be replaced each time an overload occurs. Instead, the circuit breaker can be manually reset after the overload occurs (Figure 27-39). Circuit breakers are connected into the circuit in the same manner as fuses.

27-6 QUESTIONS

1. How does a crowbar over-voltage protection circuit operate?
2. How does a fuse operate when used in a circuit?
3. What are the different types of fuses?
4. Where is the fuse of any circuit-protection device located in a circuit?
5. What is the advantage of a circuit breaker over a fuse?

SUMMARY

- Transformers are used in power supplies for isolation and to step up or step down the voltage.
 - A rectifier circuit converts incoming AC voltage to pulsating DC voltage.
 - The basic rectifier circuits are half-wave, full-wave, and bridge.
 - Half-wave rectifiers are simpler and less expensive than either full-wave or bridge rectifiers.
 - The full-wave rectifier is more efficient than the half-wave rectifier.
 - The bridge rectifier can operate without a transformer.
 - To convert pulsating DC voltage to a smooth DC voltage, a filter must follow the rectifier in the circuit.
 - A capacitor in parallel with the load is an effective filter.
 - A voltage regulator provides constant output regardless of load and input voltage changes.
 - The voltage regulator is located after the filter in the circuit.
 - The two basic types of regulator are the shunt regulator and the series regulator.
 - The series regulator is more efficient and therefore more popular than the shunt regulator.
 - Voltage multipliers are circuits capable of providing higher DC voltages than the input without the aid of a transformer.
 - Voltage doublers and voltage triplers are voltage multipliers.
 - A crowbar is a circuit designed for over-voltage protection.
 - A fuse protects a circuit from a current overload.
 - Fuses are classified as either normal or slow-blow.
 - Circuit breakers perform the same job as fuses but do not have to be replaced each time there is an overload.
- The primary purpose of a power supply is to convert AC to DC.

CHAPTER 27 SELF-TEST

1. What are the four areas of concern when selecting a transformer for a power supply?
2. What is the purpose of the transformer in a power supply?
3. What purpose does a rectifier serve with a power supply?
4. What are the advantages and disadvantages between the full-wave rectifier circuit and the bridge rectifier circuit?
5. Describe the process of how a filter capacitor converts a pulsating DC voltage to a smooth DC voltage.
6. On what basis is the size of the filter capacitor selected?
7. How does a series regulator maintain the output voltage at a constant level?
8. What circuit characteristics must be known when selecting a regulator circuit?
9. What practical use do voltage multipliers serve?
10. What advantages does a full-wave voltage doubler have over a half-wave voltage doubler?
11. What type of device(s) is used for over-voltage protection?
12. What type of device(s) is used for over-current protection?

Amplifier Basics

OBJECTIVES

After completing this chapter, the student should be able to:

- Describe the purpose of an amplifier.
- Identify the three basic configurations of transistor amplifier circuits.
- Identify the classes of amplifiers.
- Describe the operation of direct coupled amplifiers, audio amplifiers, video amplifiers, RF amplifiers, IF amplifiers, and operational amplifiers.
- Draw and label schematic diagrams for the different types of amplifier circuits.

Amplifiers are electronic circuits that are used to increase the amplitude of an electronic signal. A circuit designed to convert a low voltage to a higher voltage is called a voltage amplifier. A circuit designed to convert a low current to a higher current is called a current amplifier.



See accompanying CD for Amplifier Basics examples in MultiSim, Chapter 28.

28-1 AMPLIFIER CONFIGURATIONS

In order for a transistor to provide **amplification**, it must be able to accept an input signal and produce an output signal that is greater than the input.

The input signal controls current flow in the transistor. This, in turn, controls the voltage through the load. The transistor circuit is designed to take voltage from an external power source (V_{CC}) and apply it to a load resistor (R_L) in the form of an output voltage. The output voltage is controlled by a small input voltage.

The transistor is used primarily as an amplifying device. However, there is more than one way of achieving this amplification. The transistor can be connected in three different circuit configurations.

The three circuit configurations are the **common-base circuit**, the **common-emitter circuit**, and the **common-collector circuit**. In each configuration, one of the transistor's leads serves as a common reference point and the other two leads serve as input and output connections. Each configuration can be constructed using either NPN or PNP transistors. In each, the transistor's emitter-base

FIGURE 28-1
Common-base amplifier circuit.

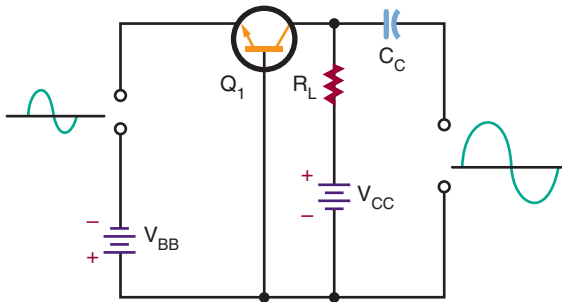
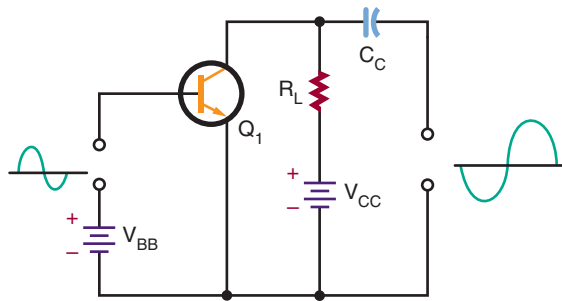


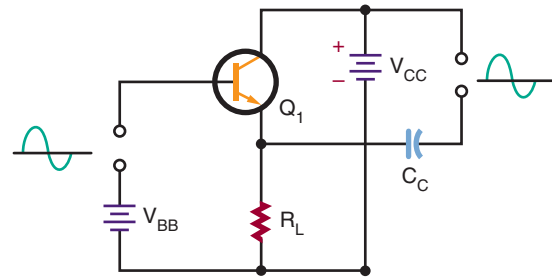
FIGURE 28-2
Common-emitter amplifier circuit.



junction is forward biased, while the collector-base junction is reverse biased. Each configuration offers advantages and disadvantages.

In the common-base circuit (Figure 28-1) the input signal enters the emitter-base circuit, and

FIGURE 28-3
Common-collector amplifier circuit.



the output leaves from the collector-base circuit. The base is the element common to both the input and output circuits.

In the common-emitter circuit (Figure 28-2) the input signal enters the base-emitter circuit, and the output signal leaves from the collector-emitter circuit. The emitter is common to both the input and output circuit. This method of connecting a transistor is the most widely used.

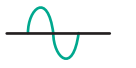

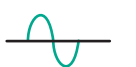
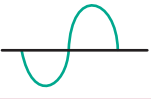
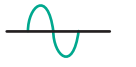
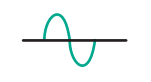
The third type of connection (Figure 28-3) is the common-collector circuit. In this configuration, the input signal enters the base-collector circuit, and the output signal leaves from the emitter-collector circuit. Here, the collector is common to both the input and output circuits. This circuit is used as an impedance-matching circuit.

Figure 28-4 charts the input-output resistance and voltage, current, and power gains for the

FIGURE 28-4
Amplifier circuit characteristics.

CIRCUIT TYPE	INPUT RESISTANCE	OUTPUT RESISTANCE	VOLTAGE GAIN	CURRENT GAIN	POWER GAIN
COMMON BASE	Low	High	High	Less than 1	Medium
COMMON EMITTER	Medium	Medium	Medium	Medium	High
COMMON COLLECTOR	High	Low	Less than 1	Medium	Medium

FIGURE 28–5
Amplifier circuit input-output phase relationships.

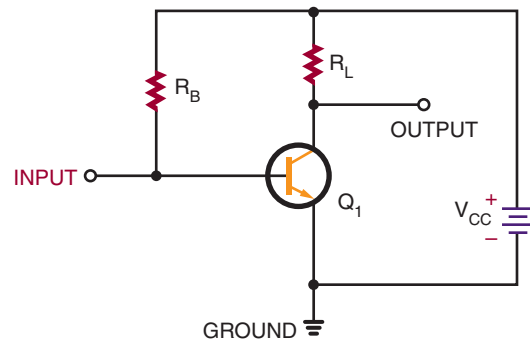
AMPLIFIER TYPE	INPUT WAVEFORM	OUTPUT WAVEFORM
COMMON BASE		
COMMON EMITTER		
COMMON COLLECTOR		

three circuit configurations. Figure 28–5 shows the phase relationship of input and output waveforms for the three configurations. Note that the common-emitter configuration provides a phase reversal of the input-output signal.

28–1 QUESTIONS

1. Draw schematic diagrams of the three basic configurations of transistor amplifier circuits.
2. List the characteristics of the:
 - a. Common-base circuit
 - b. Common-emitter circuit
 - c. Common-collector circuit
3. Make a chart showing the input-output phase relationship of the three configurations.
4. Make a chart showing the input-output resistances of the three configurations.
5. Make a chart showing the voltage, current, and power gains of the three configurations.

FIGURE 28–6
Common-emitter amplifier with single voltage source.



28–2 AMPLIFIER BIASING

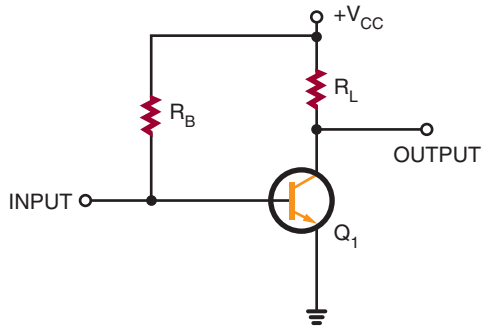
The basic configurations of transistor amplifier circuits are the common base, the common emitter, and the common collector. All require two voltages for proper biasing. The base-emitter junction must be forward biased and the base-collector junction must be reverse biased. However, both bias voltages can be provided from a single source.

Because the common-emitter circuit configuration is the most often used, it is described in detail here. The same principles apply to the common-base and common-collector circuits.

Figure 28–6 shows a common-emitter transistor amplifier using a single voltage source. The circuit is schematically diagrammed in Figure 28–7. The voltage source is identified as $+V_{CC}$. The ground symbol is the negative side of the voltage source V_{CC} . The single voltage source provides proper biasing for the base-emitter and base-collector junctions. The two resistors (R_B and R_L) are used to distribute the voltage for proper operation. Resistor R_L , the collector load resistor, is in series with the collector. When a collector current flows, a voltage develops across resistor R_L . The voltage dropped across resistor R_L and the voltage

FIGURE 28-7

Schematic representation of common-emitter amplifier with single voltage source.



dropped across the transistor's collector-to-emitter junction must add up to the total voltage applied.

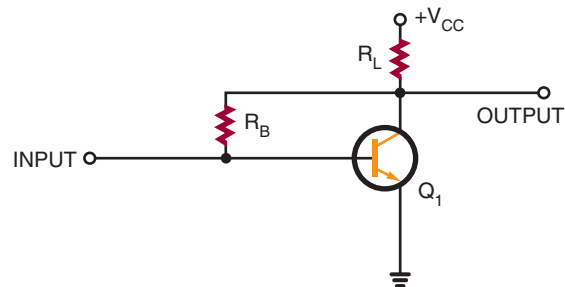
Resistor R_B , connected between the base and the voltage source, controls the amount of current flowing out of the base. The base current flowing through resistor R_B creates a voltage across it. Most of the voltage from the source is dropped across it. A small amount of voltage drops across the transistor's base-to-emitter junction, providing the proper forward bias.

The single voltage source can provide the necessary forward-bias and reverse-bias voltages. For an NPN transistor, the transistor's base and collector must be positive with respect to the emitter. Therefore, the voltage source can be connected to the base and the collector through resistors R_B and R_L . This circuit is often called a base-biased circuit, because the base current is controlled by resistor R_B and the voltage source.

The input signal is applied between the transistor's base and emitter or between the input terminal and ground. The input signal either aids or opposes the forward bias across the emitter junction. This causes the collector current to vary, which then causes the voltage across R_L to vary. The output signal is developed between the output terminal and ground.

FIGURE 28-8

Common-emitter amplifier with collector feedback.

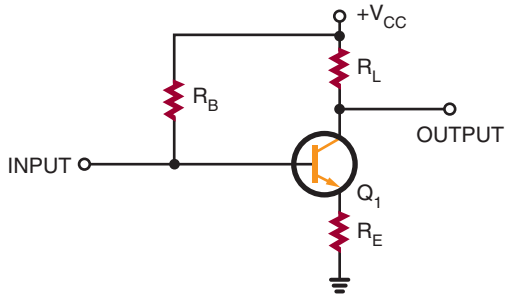


The circuit shown in Figure 28-6 is unstable, because it cannot compensate for changes in the bias current with no signal applied. Temperature changes cause the transistor's internal resistance to vary, which causes the bias currents to change. This shifts the transistor operating point, reducing the gain of the transistor. This process is referred to as *thermal instability*.

It is possible to compensate for temperature changes in a transistor amplifier circuit. If a portion of the unwanted output signal is fed back to the circuit input, the signal opposes the change. This is referred to as **degenerative** or **negative feedback** (Figure 28-8). In a circuit using degenerative feedback, the base resistor R_B is connected directly to the collector of the transistor. The current flowing through resistor R_B is determined by the voltage at the collector. If the temperature increases, the collector current increases, and the voltage across R_L increases. The collector-to-emitter voltage decreases, reducing the voltage applied to R_B . This reduces the base current, which causes the collector current to decrease. This is referred to as a *collector feedback circuit*.

Figure 28-9 shows another type of feedback. The circuit is similar to the one shown in Figure 28-7, except that a resistor R_E is connected in series with the emitter lead. Resistors R_B and R_E and the transistor's emitter-base junc-

FIGURE 28–9
Common-emitter amplifier with emitter feedback.

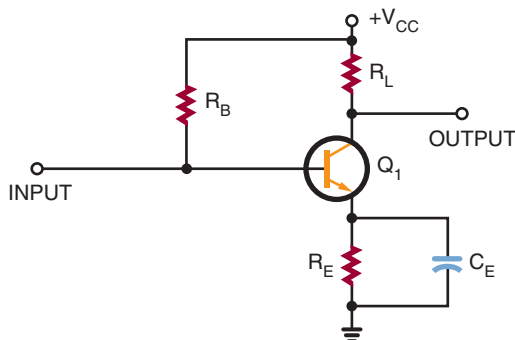


tion are connected in series with the source voltage V_{CC} .

An increase in temperature causes the collector current to increase. The emitter current then also increases, causing the voltage drop across resistor R_E to increase and the voltage across resistor R_B to decrease. The base current then decreases, which reduces both the collector current and the emitter current. Because the feedback is generated at the transistor's emitter, the circuit is called an *emitter feedback circuit*.

There is a problem with this type of circuit because an AC input signal develops across resistor R_E as well as across the load resistor R_L and the transistor. This reduces the overall gain of the circuit.

FIGURE 28–10
Emitter feedback with bypass capacitor.



circuit. With the addition of a capacitor across the emitter resistor R_E (Figure 28–10), the AC signal bypasses resistor R_E . The capacitor is often referred to as a *bypass capacitor*.

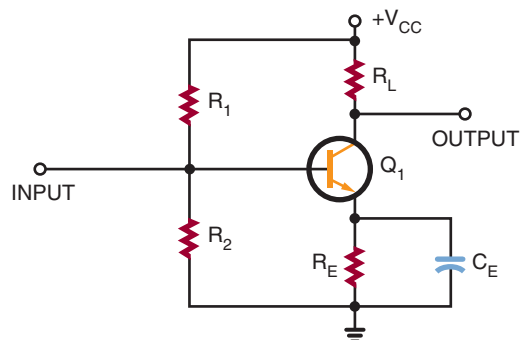
The bypass capacitor prevents any sudden voltage changes from appearing across resistor R_E by offering a lower impedance to the AC signal. The bypass capacitor holds the voltage across resistor R_E steady, while at the same time not interfering with the feedback action provided by resistor R_E .

A voltage-divider feedback circuit (Figure 28–11) offers even more stability. This circuit is the one most widely used. Resistor R_B is replaced with two resistors, R_1 and R_2 . The two resistors are connected in series across the source voltage V_{CC} . The resistors divide the source voltage into two voltages, forming a voltage divider.

Resistor R_2 drops less voltage than resistor R_1 . The voltage at the base, with respect to ground, is equal to the voltage developed across resistor R_2 . The purpose of the voltage divider is to establish a constant voltage from the base of the transistor to ground. The current flow through resistor R_2 is toward the base. Therefore, the end of resistor R_2 attached to the base is positive with respect to ground.

Because the emitter current flows up through resistor R_E , the voltage dropped across resistor R_E

FIGURE 28–11
Common-emitter amplifier with voltage-divider feedback.



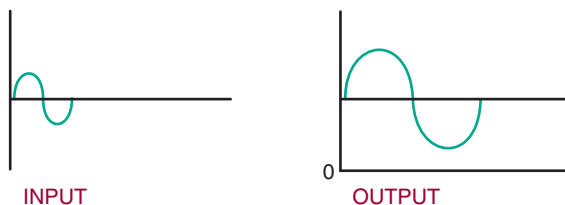
is more positive at the end that is attached to the emitter. The voltage developed across the emitter-base junction is the difference between the two positive voltages developed across resistor R_2 and resistor R_E . For the proper forward bias to occur, the base must be slightly more positive than the emitter.

When the temperature increases, the collector and emitter currents also increase. The increase in the emitter current causes an increase in the voltage drop across the emitter resistor R_E . This results in the emitter becoming more positive with respect to ground. The forward bias across the emitter-base junction is then reduced, causing the base current to decrease. The reduction in the base current reduces the collector and emitter currents. The opposite action takes place if the temperature decreases: The base current increases, causing the collector and emitter currents to increase.

The amplifier circuits discussed so far have been biased so that all of the applied AC input signal appears at the output. Except for a higher voltage, the output signal is the same as the input signal. An amplifier that is biased so that the current flows throughout the entire cycle is operating as a **class A amplifier** (Figure 28-12).

An amplifier that is biased so that the output current flows for less than a full cycle but more than a half cycle is operating as a **class AB amplifier**. More than half but less than the full AC input signal is amplified in the class AB mode (Figure 28-13).

FIGURE 28-12
Class A amplifier output.



An amplifier that is biased so that the output current flows for only half of the input cycle is operating as a **class B amplifier**. Only one-half of the AC input signal is amplified in the class B mode (Figure 28-14).

An amplifier that is biased so that the output current flows for less than half of the AC input cycle is operating as a **class C amplifier**. Less than one alternation is amplified in the class C mode (Figure 28-15).

Class A amplifiers are the most linear of the types mentioned. They produce the least amount of distortion. They also have lower output ratings and are the least efficient. They find wide application where the full signal must be maintained, as

FIGURE 28-13
Class AB amplifier output.

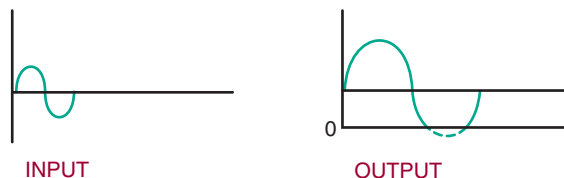


FIGURE 28-14
Class B amplifier output.

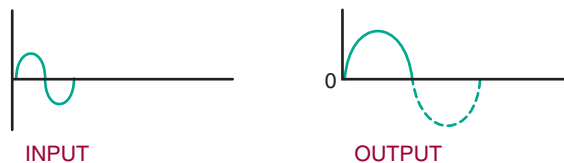


FIGURE 28-15
Class C amplifier output.

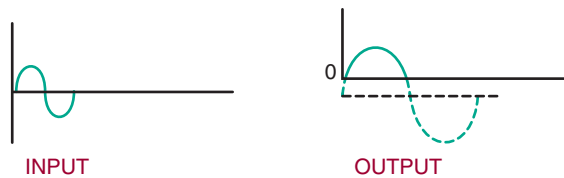
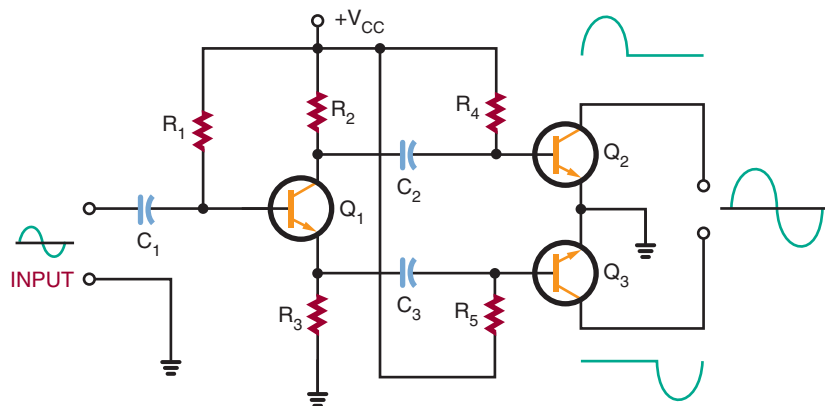


FIGURE 28–16

Push-pull amplifier configuration.



in the amplification of audio signals in radios and televisions. However, because of the high power-handling capabilities required for class A operation, transistors are usually operated in the class AB or class B mode.

Class AB, B, and C amplifiers produce a substantial amount of distortion. This is because they amplify only a portion of the input signal. To amplify the full AC input signal, two transistors are needed, connected in a push-pull configuration (Figure 28–16). Class B amplifiers are used as output stages of stereo systems and public address amplifiers, and in many industrial controls. Class C amplifiers are used for high-power amplifiers and transmitters where only a single frequency is amplified, such as the RF (radio frequency) carrier used for radio and television transmission.

28–2 QUESTIONS

1. Draw a schematic diagram of a common-emitter transistor amplifier using a single voltage source.
2. How are temperature changes compensated for in a transistor amplifier?
3. Draw a schematic diagram of a voltage-divider feedback circuit.

4. List the classes of amplifiers and identify their outputs.
5. List the applications of each class of amplifier.

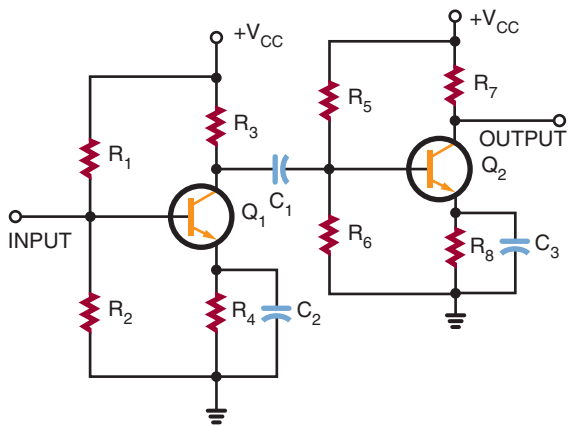
28–3 AMPLIFIER COUPLING

To obtain greater amplification, transistor amplifiers may be connected together. However, to prevent one amplifier's bias voltage from affecting the operation of the second amplifier, a **coupling** technique must be used. The coupling method used must not disrupt the operation of either circuit. Coupling methods used include resistance-capacitance coupling, impedance coupling, transformer coupling, and direct coupling.

Resistive-capacitive coupling, or *RC coupling*, consists of two resistors and a capacitor connected as shown in Figure 28–17. Resistor R_3 is the collector load resistor of the first stage. Capacitor C_1 is the DC-blocking and AC-coupling capacitor. Resistors R_5 and R_6 are the input load resistor and DC return resistor for the base-emitter junction of the second stage. Resistance-capacitive coupling is used primarily in audio amplifiers.

FIGURE 28-17

RC coupling.



Coupling capacitor C_1 must have a low reactance to minimize low-frequency attenuation. Typically, a high-capacitance value of 10 to 100 microfarads is used. The coupling capacitor is generally an electrolytic type.

The reactance of the coupling capacitor increases as the frequency decreases. The low-frequency limit is determined by the size of the coupling capacitor. The high-frequency limit is determined by the type of transistor used.

The *impedance-coupling* method is similar to the RC-coupling method, but an inductor is used in place of the collector load resistor for the first stage of amplification (Figure 28-18).

Impedance coupling works just like RC coupling. The advantage is that the inductor has a very low DC resistance across its windings. The AC output signal is developed across the inductor just as across the load resistor. However, the inductor consumes less power than the resistor, increasing the overall efficiency of the circuit.

The disadvantage of impedance coupling is that the inductance reactance increases with the frequency. The voltage gain varies with the frequency. This type of coupling is ideal for single-frequency amplification when a very narrow band of frequencies must be amplified.

FIGURE 28-18

Impedance coupling.

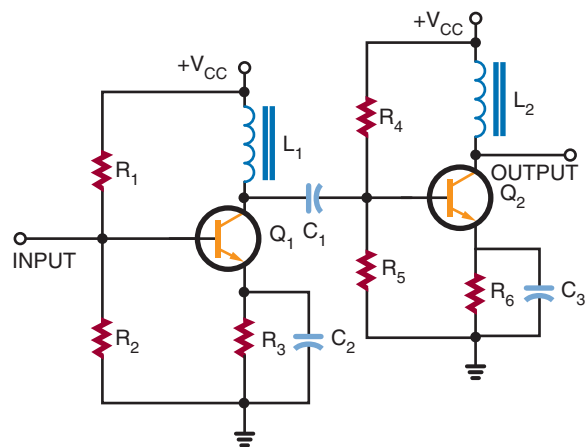
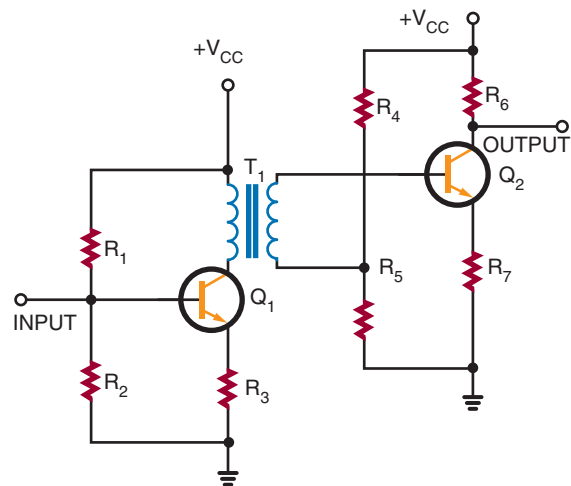


FIGURE 28-19

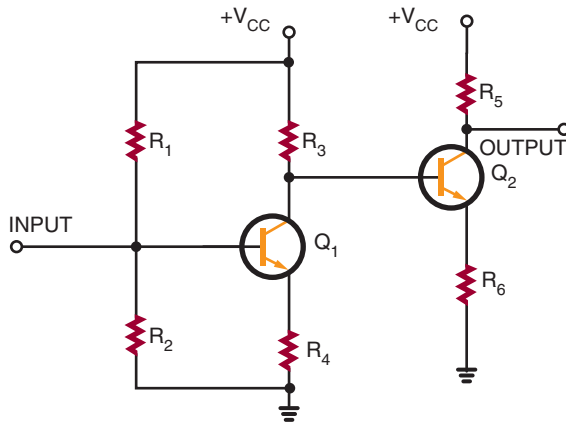
Transformer coupling.



In a *transformer-coupled* circuit, the two amplifier stages are coupled through the transformer (Figure 28-19). The transformer can effectively match a high-impedance source to a low-impedance load. The disadvantage is that transformers are large and expensive. Also, like the inductor-coupled amplifier, the transformer-coupled amplifier is useful only for a narrow band of frequencies.

FIGURE 28–20

Direct coupling.



When very low frequencies or a DC signal must be amplified, the *direct-coupling* technique must be used (Figure 28–20). Direct-coupled amplifiers provide a uniform current or voltage gain over a wide range of frequencies. This type of amplifier can amplify frequencies from zero (DC) hertz to many thousands of hertz. However, direct-coupled amplifiers find their best applications with low frequencies.

A drawback of direct-coupled amplifiers is that they are not stable. Any change in the output current of the first stage is amplified by the second stage. This occurs because the second stage is essentially biased by the first stage. To improve the stability requires the use of expensive precision components.

28–3 QUESTIONS

1. What are the four main methods of coupling transistor amplifiers?
2. Where is resistance-capacitive coupling primarily used?
3. What is the difference between resistance-capacitive coupling and impedance coupling?

4. What is the disadvantage of transformer coupling?
5. What coupling method is used for DC and low-frequency signals?

SUMMARY

- Amplifiers are electronic circuits used to increase the amplitude of an electronic signal.
- The transistor is used primarily as an amplifying device.
- The three transistor amplifier configurations are common base, common collector, and common emitter.
- Common-collector amplifiers are used for impedance matching.
- Common-emitter amplifiers provide phase reversal of the input-output signal.
- All transistor amplifiers require two voltages for proper biasing.
- A single voltage source can provide the necessary forward-bias and reverse-bias voltages using a voltage-divider arrangement.
- A voltage-divider feedback arrangement is the most commonly used biasing arrangement.
- A transistor amplifier can be biased so that all or part of the input signal is present at the output.
- Class A amplifiers are biased so that the output current flows throughout the cycle.
- Class AB amplifiers are biased so that the output current flows for less than the full but more than half of the input cycle.
- Class B amplifiers are biased so that the output current flows for only half of the input cycle.
- Class C amplifiers are biased so that the output current flows for less than half of the input cycle.

- Coupling methods used to connect one transistor to another include resistance-capacitance coupling, impedance coupling, transformer coupling, and direct coupling.
- Direct-coupled amplifiers are used for high gain at low frequencies or amplification of a DC signal.

CHAPTER 28 SELF-TEST

1. Briefly describe how a transistor is used to provide amplification.
2. Why is the common-emitter amplifier the most widely used transistor amplifier configuration?
3. What factor affects the gain of the transistor, and what must be done to compensate for it?
4. How does an amplifier's class of operation affect the biasing of the amplifier?
5. What factor must be taken into consideration when connecting one amplifier to another?
6. How does the frequency of operation of an amplifier affect the coupling method used in connecting amplifiers together?

Amplifier Applications

OBJECTIVES

After completing this chapter, the student should be able to:

- Describe the operation of:
 - direct coupled amplifiers
 - audio amplifiers
 - video amplifiers
 - RF amplifiers
 - IF amplifiers
 - operational amplifiers
- Identify schematic diagrams for the different types of amplifier circuits.

An amplifier may be defined as an electronic circuit designed to increase the amplitude of an electronic signal. Amplifier circuits are one of the most basic circuits in electronics. Amplifier circuits make signal level greater, sound louder, and provide the circuit with gain. Gain is the ability of an electronic circuit to increase the amplitude of an electronic signal. This chapter looks at some unique types of amplifier circuits.



See accompanying CD for Amplifier Application examples in MultiSim, Chapter 29.

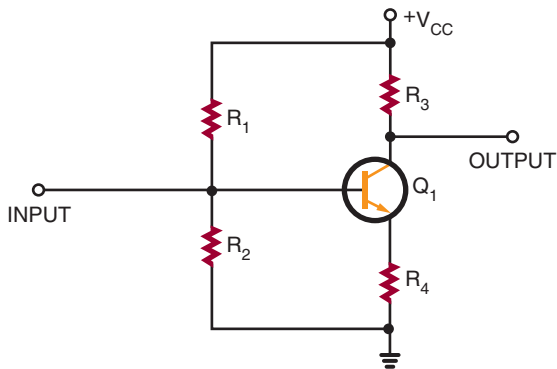
29-1 DIRECT-COUPLED AMPLIFIERS

Direct-coupled or **DC amplifiers** are used for high gain at low frequencies or for amplification of a direct-current signal. The DC amplifier is also used to eliminate frequency loss through a coupling network. Applications of the DC amplifier include

computers, measuring and test instruments, and industrial control equipment.

A simple DC amplifier is shown in Figure 29-1. The common-emitter amplifier is the one most frequently used. The circuit is shown with voltage-divider bias and emitter feedback. This type of circuit does not use a coupling capacitor. The input is applied directly to the base of

FIGURE 29-1
Simple DC amplifier.



the transistor. The output is taken from the collector.

The DC amplifier can provide both voltage and current gain. However, it is used primarily as a voltage amplifier. The voltage gain is uniform for both AC and DC signals.

In most applications, one stage of amplification is not enough. Two or more stages are required to obtain a higher gain. Two or more stages connected together are referred to as a *multiple-stage amplifier*. Figure 29-2 shows a two-stage amplifier. The input signal is amplified by the first stage. The amplified signal is then applied to the base of the transistor in the second stage. The

FIGURE 29-2
Two-stage DC amplifier.

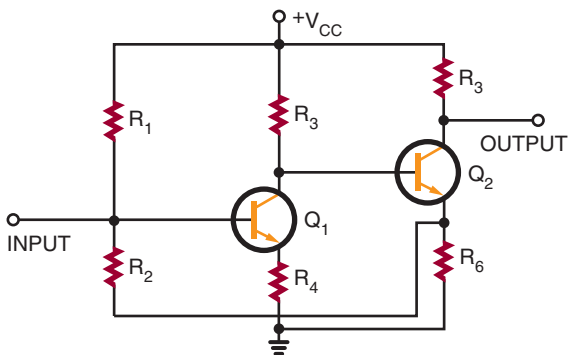
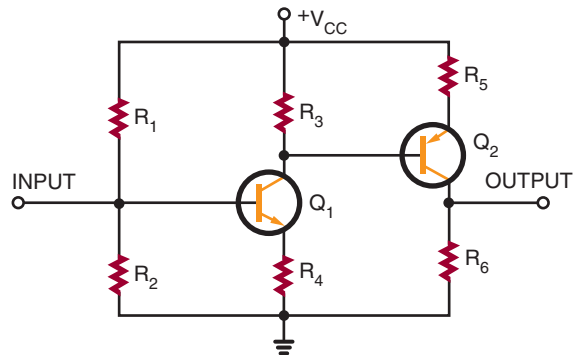


FIGURE 29-3
Complementary DC amplifier.



overall gain of the circuit is the product of the voltage gains of the two stages. For example, if both the first and second stages have a voltage gain of 10, the overall gain of the circuit is 100.

Figure 29-3 shows another type of two-stage DC amplifier. Both an NPN and a PNP transistor are used. The type of circuit is called a *complementary amplifier*. The circuit functions the same way as the circuit shown in Figure 29-2. The difference is that the second-stage transistor is a PNP transistor. The PNP transistor is reversed so that the emitter and collector are biased properly.

Figure 29-4 shows two transistors connected together to function as a single unit. This circuit arrangement is called a *darlington arrangement*. Transistor Q_1 is used to control the conduction of transistor Q_2 . The input signal applied to the base of transistor Q_1 controls the base of transistor Q_2 . The darlington arrangement may be a single package with three leads: emitter (E), base (B), and collector (C). It is used as a simple DC amplifier but offers a very high voltage gain.

The main disadvantage of multiple-stage amplifiers is their high thermal instability. In circuits requiring three or four stages of DC amplification, the final output stage may not amplify the original DC or AC signal but one that has been greatly distorted. The same problem exists with the darlington arrangement.

FIGURE 29-4
Darlington arrangement.

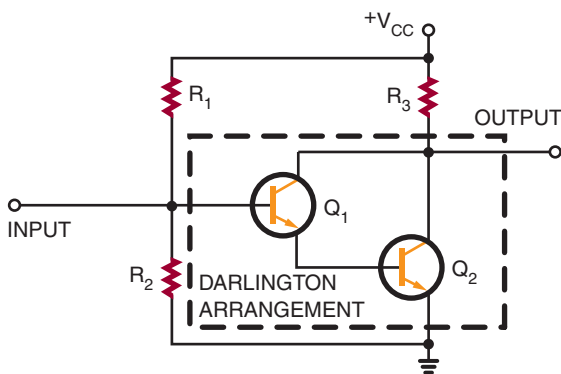
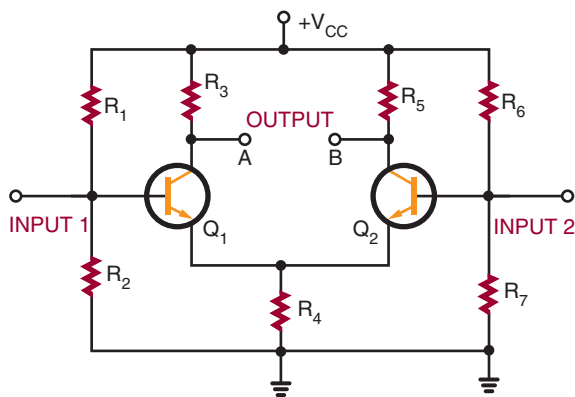


FIGURE 29-5
Differential amplifier.



In applications where both high gain and temperature stability are required, another type of amplifier is necessary. This type is called a **differential amplifier** (Figure 29-5). It is unique in that it has two separate inputs and can provide either one or two outputs. If a signal is applied to the input of transistor Q_1 , an amplified signal is produced between output A and ground as in an ordinary amplifier. However, a small signal is also developed across resistor R_4 and is applied to the emitter of transistor Q_2 . Transistor Q_2 functions as a common-base amplifier and amplifies the signal on its base. An amplified output signal is produced

between output B and ground. The output produced at B is 180 degrees out of phase with output A. This makes the differential amplifier much more versatile than a conventional amplifier.

The differential amplifier is generally not used to obtain an output between either output and ground. The output signal is usually obtained between output A and output B. Because the two outputs are 180 degrees out of phase, a substantial output voltage is developed between the two points. The input signal can be applied to either input.

The differential amplifier has a high degree of temperature stability, because transistors Q_1 and Q_2 are mounted close together and therefore are equally affected by temperature changes. Also, the collector currents of transistors Q_1 and Q_2 tend to increase and decrease by the same amount, so that the output voltage remains constant.

The differential amplifier is used extensively in integrated circuits and electronic equipment in general. It is used to amplify and/or compare the amplitudes of both DC and AC signals. It is possible to connect one or more differential amplifiers together to obtain a higher overall gain. In some cases, the differential amplifier is used as a first stage, with conventional amplifiers used in succeeding circuits. Because of their versatility and temperature stability, differential amplifiers are the most important type of direct-coupled amplifier.

29-1 QUESTIONS

1. When are direct-coupled amplifiers used in a circuit?
2. What kind of amplifiers are direct-coupled amplifiers primarily used for?
3. Draw schematic diagrams of the following circuits:
 - a. Complementary amplifier
 - b. Darlington arrangement
 - c. Differential amplifier

4. How does a differential amplifier differ from a conventional amplifier?
5. Where are differential amplifiers primarily used?

29-2 AUDIO AMPLIFIERS

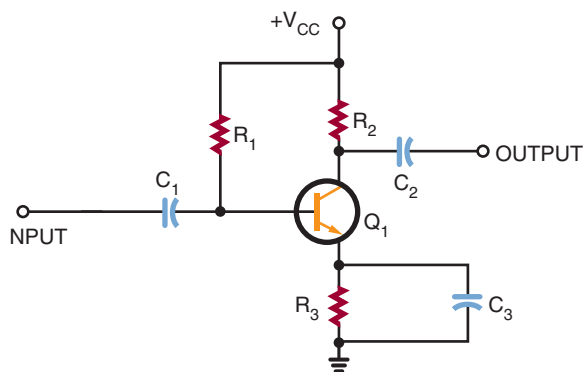
Audio amplifiers amplify AC signals in the frequency range of approximately 20 to 20,000 hertz. They may amplify the whole audio range or only a small portion of it.

Audio amplifiers are divided into two categories: **voltage amplifiers** and **power amplifiers**. Voltage amplifiers are primarily used to produce a high voltage gain. Power amplifiers are used to deliver a large amount of power to a load. For example, a voltage amplifier is typically used to increase the voltage level of a signal sufficiently to drive a power amplifier. The power amplifier then supplies a high output to drive a load such as a loudspeaker or other high-power device. Typically, voltage amplifiers are biased to operate as class A amplifiers, and power amplifiers are biased to operate as class B amplifiers.

Figure 29-6 shows a simple voltage amplifier. The circuit shown is a common-emitter circuit. It

FIGURE 29-6

Voltage amplifier.



is biased class A to provide a minimum amount of distortion. The amplifier can provide a substantial voltage gain over a wide frequency range. Because of the coupling capacitors, the circuit cannot amplify a DC signal.

Two or more voltage amplifiers can be connected together to provide higher amplification. The stages may be RC coupled or transformer coupled. Transformer coupling is more efficient. The transformer is used to match the input and output impedance of the two stages. This keeps the second stage from loading down the first stage. *Loading down* is the condition when a device creates too large a load and severely affects the output by drawing too much current. The transformer used to link the two stages together is called an *interstage transformer*.

Once a sufficient voltage level is available, a power amplifier is used to drive the load. Power amplifiers are designed to drive specific loads and are rated in watts. Typically a load may vary from 4 to 16 ohms.

Figure 29-7 shows a two-transistor power amplifier circuit, called a *push-pull amplifier*. The top half of the circuit is a mirror image of the bottom half. Each half is a single transistor amplifier. The output voltage is developed across the primary of the transformer during alternate half-cycles of the input signal. Both transistors are biased either class AB or class B. The input to a push-pull amplifier requires complementary signals. That is, one signal must be inverted compared to the other. However, both signals must have the same amplitude and the same frequency. The circuit that produces the complementary signal is called a *phase splitter*. A single-transistor phase splitter is shown in Figure 29-8. The complementary outputs are taken from the collector and the emitter of the transistor. The phase splitter is operated as a class A amplifier to provide minimum distortion. The coupling capacitors are necessary to offset the differences between the DC collector and emitter voltages.

A push-pull amplifier that does not require a phase splitter is called a *complementary push-pull*

FIGURE 29-7
Push-pull power amplifier.

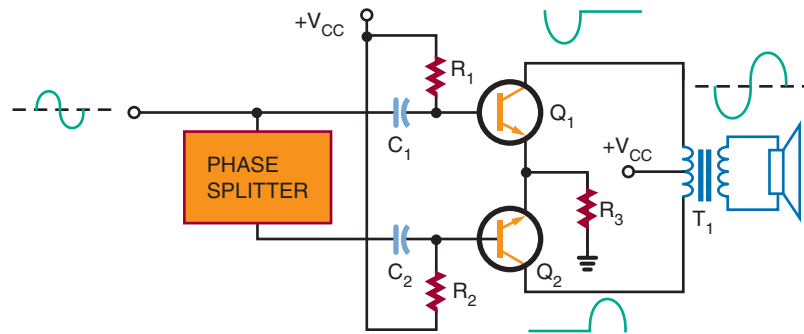


FIGURE 29-8
Phase splitter.

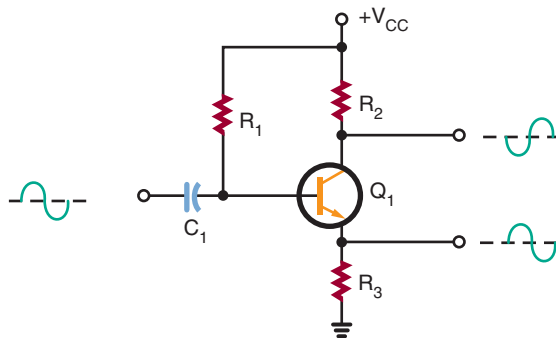
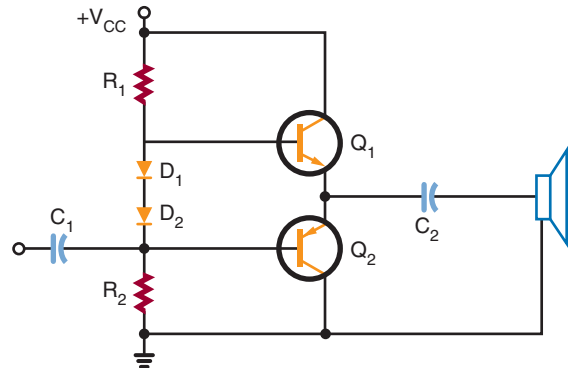


FIGURE 29-9
Complementary push-pull power amplifier.



amplifier. It uses an NPN and a PNP transistor to accomplish the push-pull action (Figure 29-9). The two transistors are connected in series with their emitters together. When each transistor is properly biased, there is 0.7 volt between the base and emitter or 1.4 volts between the two bases. The two diodes help to keep the 1.4-volt difference constant. The output is taken from between the two emitters through a coupling capacitor.

For amplifiers greater than 10 watts, it is difficult and expensive to match NPN and PNP transistors to ensure that they have the same characteristics. Figure 29-10 shows a circuit that uses two NPN transistors for the output-power transistors. The power transistors are driven by

FIGURE 29-10
Quasi-complementary power amplifier.

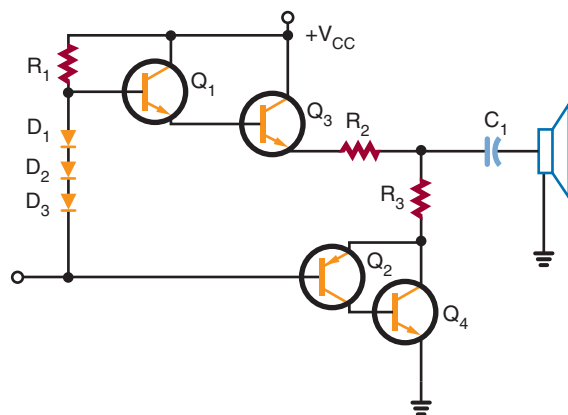
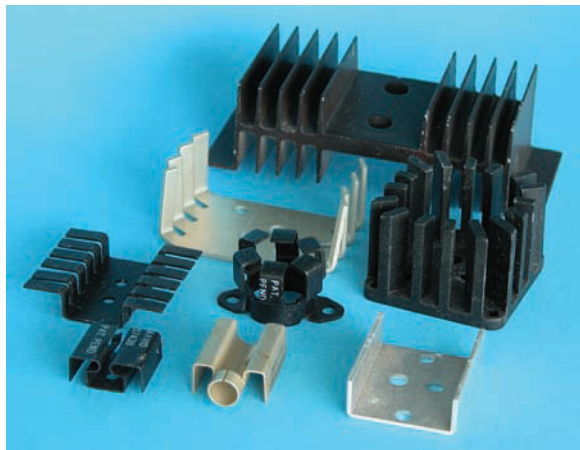


FIGURE 29–11

One type of heat sink available.



lower-power NPN and PNP transistors while the upper set of transistors is connected in a darlington configuration. The lower set of transistors uses a PNP and an NPN transistor. Operating as a single unit, they respond like a PNP transistor. This type of amplifier is called a *quasi-complementary amplifier*. It operates like a complementary amplifier but does not require high-power complementary output transistors.

Because of the large amounts of power generated by power amplifiers, some components get hot. To assist in the removal of this heat buildup, a heat sink is used. A *heat sink* is a device that provides a large area from which the heat can radiate. Figure 29–11 shows different types of heat sinks used with transistors.

29–2 QUESTIONS

1. For what frequency range are audio amplifiers used?
2. What are the two types of audio amplifiers?

3. What is an interstage transformer?
4. Draw schematic diagrams of the following:
 - a. Push-pull amplifier
 - b. Complementary push-pull amplifier
 - c. Quasi-complementary amplifier

29–3 VIDEO AMPLIFIERS

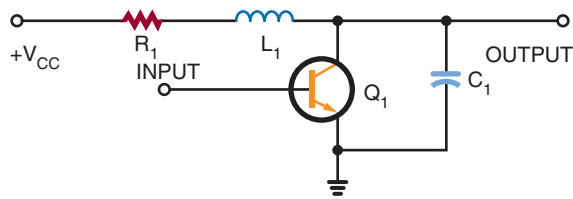
Video amplifiers are wideband amplifiers used to amplify video (picture) information. The frequency range of the video amplifier is greater than that of the audio amplifier, extending from a few hertz to 5 or 6 megahertz. For example, a television requires a uniform bandwidth of 60 hertz to 4 megahertz. Radar requires a bandwidth of 30 hertz to 2 megahertz. In circuits that use sawtooth or pulse waveforms, it is necessary to cover a range of frequencies from one-tenth of the lowest frequency to ten times the highest frequency. The extended range is necessary because nonsinusoidal waveforms contain many harmonics and they must all be amplified equally.

Because video amplifiers require good uniformity in frequency response, only direct or RC coupling is used. Direct coupling provides the best frequency response, whereas RC coupling has economic advantages. The RC-coupled amplifier also has a flat response in the middle frequency range that is suitable for video amplifiers. *Flat response* is the term used to indicate that the gain of an amplifier varies only slightly within a stated frequency range. The response curve plotted for such an amplifier is almost a straight line; hence the term “flat response.”

A factor that limits the high-frequency response in a transistor amplifier is the shunt capacitance of the circuit. A small capacitance exists

FIGURE 29-12

Shunt peaking.



between the junctions of the transistor. The capacitance is determined by the size of the junction and the spacing between the transistor's leads. The capacitance is further affected by the junction bias. A forward-biased base-emitter junction has a greater capacitance than a reverse-biased collector-base junction.

To reduce the effects of shunt capacitance and increase the frequency response in transistor video amplifiers, peaking coils are used. Figure 29-12 shows the *shunt-peaking* method. A small inductor is placed in series with the load resistor. At the low- and mid-frequency range, the peaking coil will have little effect on the amplifier re-

sponse. At the higher frequencies, the inductor resonates with the circuit's capacitance, which results in an increase in the output impedance and boosts the gain.

Another method is to insert a small inductor in series with the interstage coupling capacitor. This method is called *series peaking* (Figure 29-13). The peaking coil effectively isolates the input and output capacitance of the two stages.

Often series and shunt peaking are combined to gain the advantages of both (Figure 29-14). This combination can extend the bandwidth to over 5 megahertz.

The most common use of video amplifiers is in television receivers and computer monitors. (Figure 29-15). Transistor Q_1 is connected as an emitter-follower. Input to transistor Q_1 is from the video detector. The video detector recovers the video signal from the intermediate frequency. In the collector circuit of transistor Q_2 is a shunt-peaking coil (L_1). In the signal-output path is a series-peaking coil (L_2). The video signal is then coupled to the picture tube through coupling capacitor C_5 .

FIGURE 29-13

Series peaking.

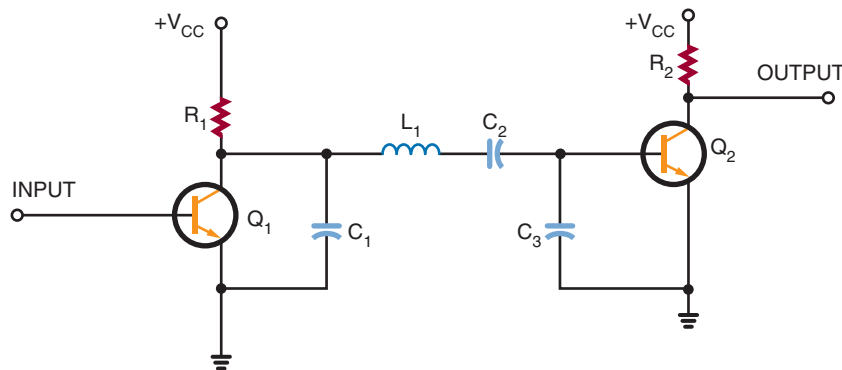


FIGURE 29-14

Series-shunt peaking.

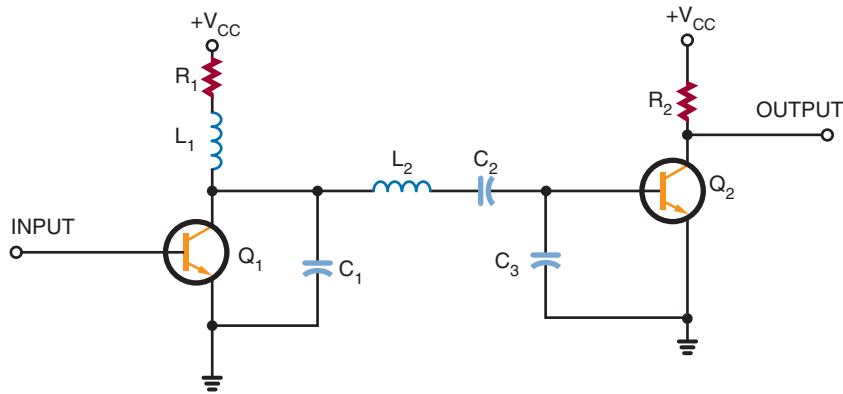
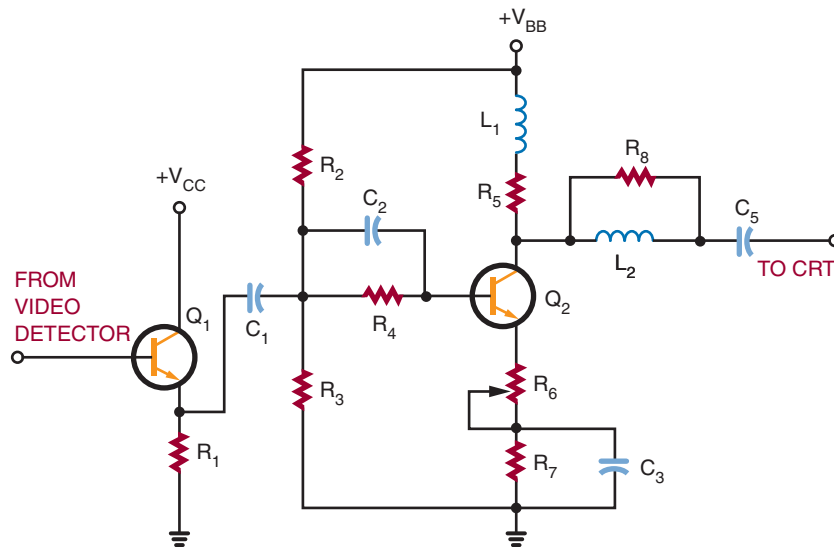


FIGURE 29-15

Video amplifier in a television receiver.



29-3 QUESTIONS

1. What is a video amplifier?
2. What is the frequency range of a video amplifier?
3. What coupling techniques are used for video amplifiers?
4. Define the following:
 - a. Shunt peaking
 - b. Series peaking
5. Where are video amplifiers used?

29-4 RF AND IF AMPLIFIERS

RF (radio-frequency) amplifiers usually are the first stage in an AM, FM, or TV receivers and are similar to other amplifiers. They differ primarily in the frequency spectrum over which they operate, which is 10,000 to 30,000 megahertz. There are two classes of RF amplifiers: untuned and tuned. In an *untuned amplifier*, a response is desired over a large RF range, and the main function is amplification. In a *tuned amplifier*, high amplification is desired over a small range of frequencies or a single frequency. Normally, when RF amplifiers are mentioned, they are assumed to be tuned unless otherwise specified.

In receiving equipment, the RF amplifier serves to amplify the signal and select the proper frequency. In transmitters, the RF amplifier serves to amplify a single frequency for application to the antenna. Basically, the receiver RF amplifier is a voltage amplifier, and the transmitter RF amplifier is a power amplifier.

In a receiver circuit, the RF amplifier must provide sufficient gain, produce low internal noise, provide good selectivity, and respond well to the selected frequencies.

Figure 29-16 shows an RF amplifier used for an AM radio. Capacitors C_1 and C_4 tune the antenna and the output transformer T_1 to the same frequency. The input signal is magnetically coupled to the base of transistor Q_1 . Transistor Q_1 operates as a class A amplifier. Capacitor C_4 and transformer T_1 provide a high voltage gain at the resonant frequency for the collector load circuit. Transformer T_1 is tapped to provide a good impedance match for the transistor.

Figure 29-17 shows an RF amplifier used in a television VHF tuner. The circuit is tuned by coils L_{1A} , L_{1B} , and L_{1C} . When the channel selector is turned, a new set of coils is switched into the circuit. This provides the necessary bandwidth response for each channel. The input signal is developed across the tuned circuit consisting of L_{1A} , C_1 , and C_2 . Transistor Q_1 operates as a class A amplifier. The collector-output circuit is a double-tuned transformer. Coil L_{1B} is tuned by capacitor

FIGURE 29-16
RF amplifier in an AM radio.

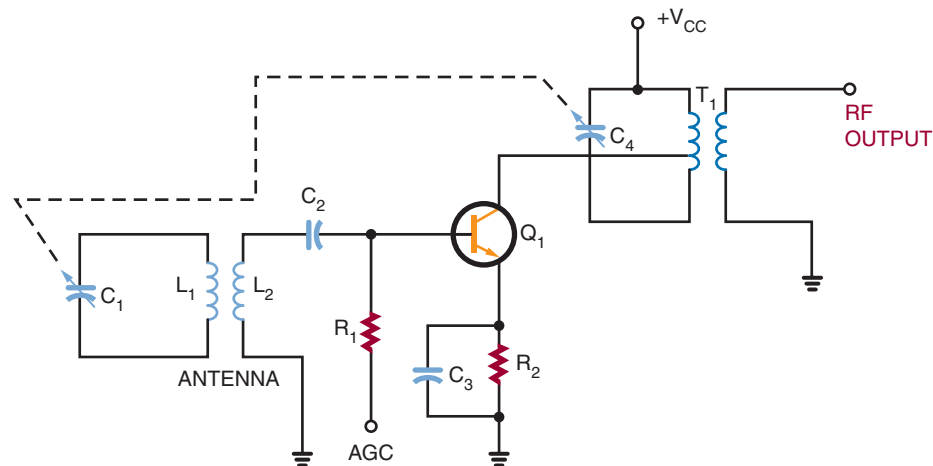
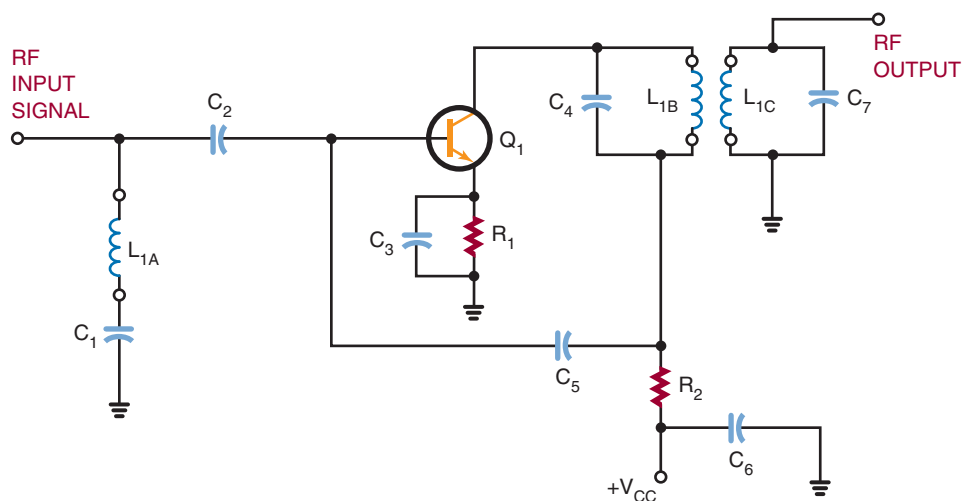


FIGURE 29-17

RF amplifier in a television VHF tuner.



C_4 and coil L_{1C} is tuned by capacitor C_7 . Resistor R_2 and capacitor C_6 form a decoupling filter to prevent any RF from entering the power supply to interact with other circuits.

In an AM radio, the incoming RF signal is converted to a constant **IF (intermediate frequency) signal**. A fixed-tuned IF amplifier is then used to increase the signal to a usable level. The IF amplifier is a single-frequency amplifier. Typically, two

or more IF amplifiers are used to increase the signal to the proper level. The sensitivity of a receiver is determined by its signal-to-noise (S/N) ratio. The higher the gain, the better the sensitivity. Figure 29-18 shows a typical IF amplifier in an AM radio. The IF frequency is 455,000 hertz. Figure 29-19 shows an IF amplifier in a television receiver. Figure 29-20 compares the frequencies of radio and television receivers.

FIGURE 29-18

IF amplifier in an AM radio.

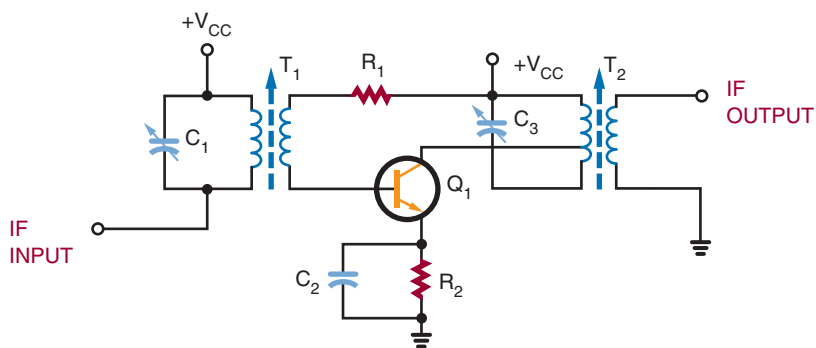


FIGURE 29–19

IF amplifier in a television receiver.

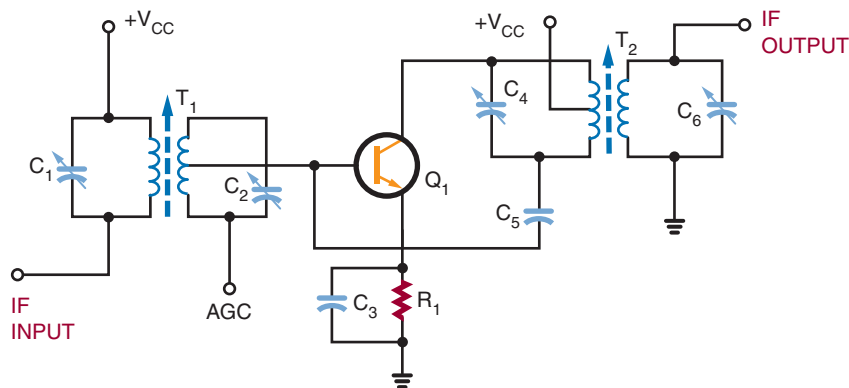


FIGURE 29–20

Comparison of radio and television frequencies.

TYPE	RECEIVED RF	COMMON IF	BANDWIDTH
AM Radio	535-1605 kHz	455 kHz	10 kHz
FM Radio	88-108 MHz	10.7 MHz	150 kHz
Television			
Channels 2-6	54-88 MHz		
Channels 7-13	174-216 MHz	41-47 MHz	6 MHz
Channels 14-83	470-890 MHz		

29–4 QUESTIONS

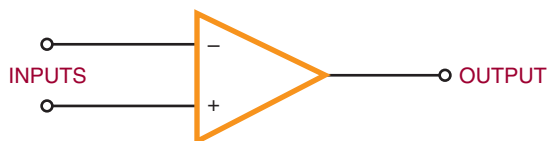
1. How do RF amplifiers differ from other amplifiers?
2. What are the two types of RF amplifiers?
3. Where are RF amplifiers used?
4. What is an IF amplifier?
5. What is significant about an IF amplifier?

29–5 OPERATIONAL AMPLIFIERS

Operational amplifiers are usually called **op-amps**. An op-amp is a very high-gain amplifier used to amplify both AC and DC signals. Typically, op-amps have an output gain in the range of 20,000 to 1,000,000 times the input. Figure 29–21 shows the schematic symbol used for op-amps. The negative (–) input is called the *inverting input*

FIGURE 29–21

Schematic symbol for an op-amp.



and the positive (+) is called the *noninverting input*.

Figure 29–22 is a block diagram of an op-amp. The op-amp consists of three stages. Each stage is an amplifier with some unique characteristic.

The input stage is a differential amplifier. It allows the op-amp to respond only to the differences between input signals. Also, the differential amplifier amplifies only the differential input voltage and is unaffected by signals common to both inputs. This is referred to as *common-mode rejection*. Common-mode rejection is useful when measuring a small signal in the presence of 60-hertz noise. The 60-hertz noise common to both inputs is rejected, and the op-amp amplifies only the small difference between the two inputs. The differential amplifier has a low-frequency response that extends down to a DC level. This means that the differential amplifier can respond not only to low-frequency AC signals but to DC signals as well.

The second stage is a high-gain voltage amplifier. This stage is composed of several darlington-

pair transistors. This stage provides a voltage gain of 200,000 or more and supplies most of the op-amp's gain.

The last stage is an output amplifier. Typically, this is a complementary emitter-follower amplifier. It is used to give the op-amp a low output impedance. The op-amp can deliver several milliamperes of current to a load.

Generally, op-amps are designed to be powered by a dual-voltage power supply in the range of ± 5 to ± 15 volts. The positive power source delivers +5 to +15 volts with respect to ground. The negative power source delivers -5 to -15 volts with respect to ground. This allows the output voltage to swing from positive to negative with respect to ground. However, in certain cases, op-amps may be operated from a single voltage source.

A schematic diagram of a typical op-amp is shown in Figure 29–23. The op-amp shown is called a 741. This op-amp does not require frequency compensation, is short-circuit protected, and has no latch-up problems. It provides good performance for a low price and is the most commonly used op-amp. A device that contains two 741 op-amps in a single package is called a 747 op-amp. Because no coupling capacitors are used, the circuit can amplify DC signals as well as AC signals.

The op-amp's normal mode of operation is a closed loop. The **closed-loop mode** uses feedback, as compared to the **open-loop mode**, which does not use feedback. A lot of degenerative feedback is used

FIGURE 29–22

Block diagram of an op-amp.

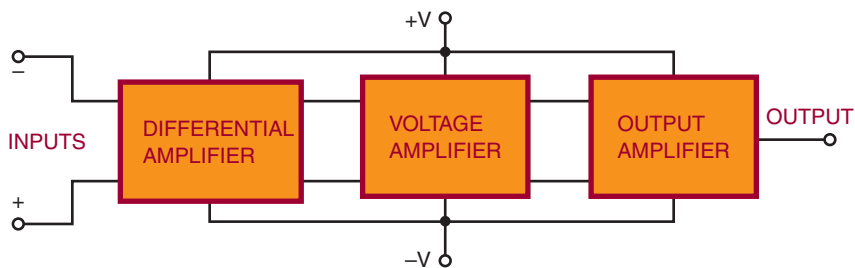


FIGURE 29-23

Schematic diagram of an op-amp. (Courtesy of National Semiconductor Corporation.)



Operational Amplifiers/Buffers

LM741/LM741A/LM741C/LM741E Operational Amplifier

General Description

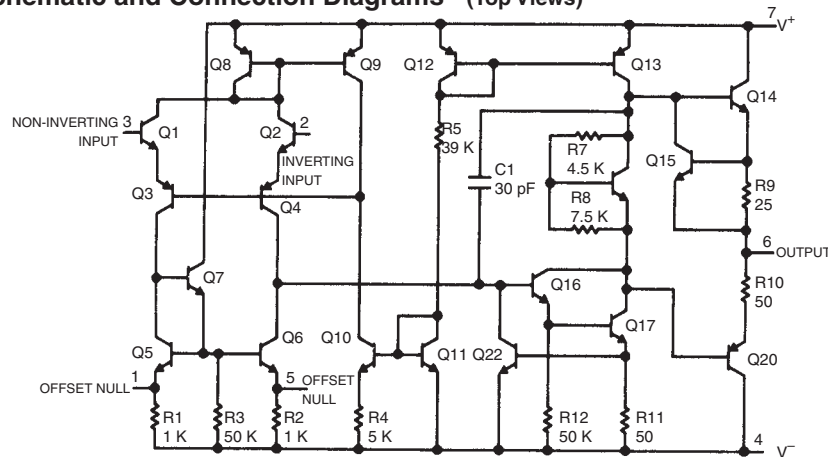
The LM741 series are general purpose operational amplifiers which feature improved performance over industry standards like the LM709. They are direct, plug-in replacements for the 709C, LM201, MC1439 and 748 in most applications.

The amplifiers offer many features which make their application nearly foolproof: overload pro-

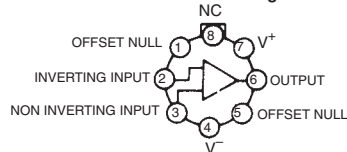
tection on the input and output, no latch-up when the common mode range is exceeded, as well as freedom from oscillations.

The LM741C/LM741E are identical to the LM741/LM741A except that the LM741C/LM741E have their performance guaranteed over a 0°C to +70°C temperature range, instead of -55°C to +125°C.

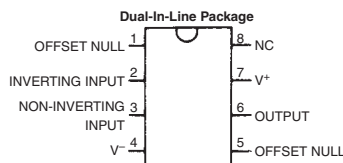
Schematic and Connection Diagrams (Top Views)



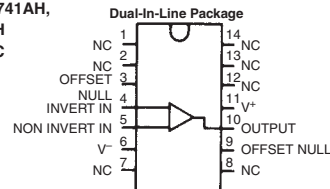
Metal Can Package



Order Number LM741H, LM741AH,
LM741CH or LM741EH
See NS Package H08C



Order Number LM741CN or LM741EN
See NS Package N08B
Order Number LM741CJ
See NS Package J08A



Order Number LM741CN-14
See NS Package N14A
Order Number LM741J-14, LM741AJ-14
or LM741CJ-14
See NS Package J14A

with the closed-loop mode. This reduces the overall gain of the op-amp but provides better stability.

In closed-loop operation, the output signal is applied back to one of the input terminals as a feedback signal. This feedback signal opposes the input signal. There are two basic closed-loop circuits: inverting and noninverting. The inverting configuration is more popular.

Figure 29–24 shows the op-amp connected as an *inverting amplifier*: The input signal is applied to the op-amp's inverting (–) input through resistor R_1 . The feedback is provided through resistor R_2 . The signal at the inverting input is determined by both the input and output voltages.

A minus sign indicates a negative output signal when the input signal is positive. A plus sign indicates a positive output signal when the input signal is negative. The output is 180 degrees out of phase with the input. Depending on the ratio of resistor R_2 to R_1 , the gain of the inverting amplifier can be less than, equal to, or greater than 1. When the gain is equal to 1, it is called a *unity-gain amplifier* and is used to invert the polarity of the input signal.

Figure 29–25 shows an op-amp connected as a *noninverting amplifier*: The output signal is in phase with the input. The input signal is applied to the op-amp's noninverting input. The output voltage is divided between resistors R_1 and R_2 to produce a voltage that is fed back to the inverting (–) input. The voltage gain of a noninverting input amplifier is always greater than 1.

FIGURE 29–24

Op-amp connected as an inverting amplifier.

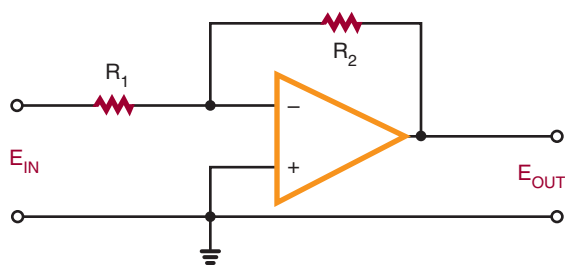
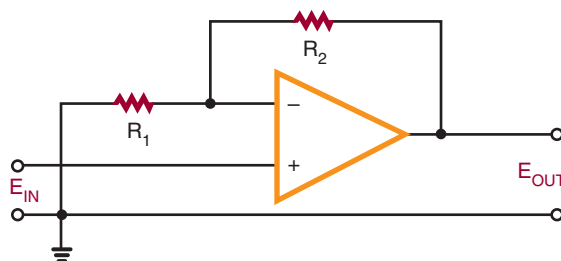


FIGURE 29–25

Op-amp connected as a noninverting amplifier.

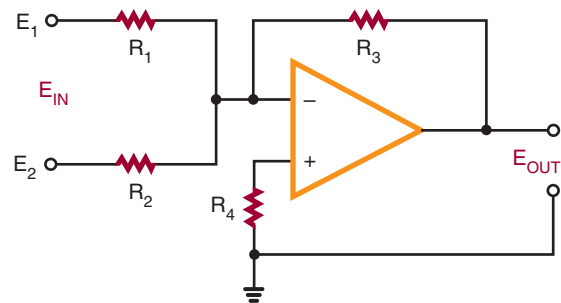


The gain of an op-amp varies with frequency. Typically, the gain given by a specification sheet is the DC gain. As the frequency increases, the gain decreases. Without some means to increase the bandwidth, the op-amp is only good for amplifying a DC signal. To increase the bandwidth, feedback is used to reduce the gain. By reducing the gain, the bandwidth increases by the same amount. In this way, the 741 op-amp bandwidth can be increased to 1 megahertz.

Besides its use for comparing, inverting, or noninverting a signal, the op-amp has several other applications. It can be used to add several signals together as shown in Figure 29–26. This is referred to as a *summing amplifier*. The negative feedback holds the inverting input of the op-amp very close to ground potential. Therefore, all the input signals are electrically isolated from each other. The output of the amplifier is the inverted sum of the input signal.

FIGURE 29–26

Op-amp connected as a summing amplifier.



In a summing amplifier, the resistor chosen for the noninverting input-to-ground is equal to the total parallel resistance of the input and feedback resistances. If the feedback resistance is increased, the circuit can provide gain. If different input resistances are used, the input signals can be added together with different gains.

Summing amplifiers are used when mixing audio signals together. Potentiometers are used for the input resistances to adjust the strength of each of the input signals.

Op-amps can also be used as active filters. Filters that use resistors, inductors, and capacitors are called **passive filters**. **Active filters** are inductorless filters using integrated circuits. The advantage of active filters is the absence of inductors, which is handy at low frequencies because of the size of inductors.

There are some disadvantages when using op-amps as active filters because they require a power supply, can generate noise, and can oscillate due to thermal drift or aging components.

Figure 29–27 shows an op-amp used as a high-pass filter. A high-pass filter rejects low frequencies while passing frequencies above a certain cut-off frequency. Figure 29–28 shows an op-amp used as a low-pass filter. A low-pass filter passes low frequencies while blocking frequencies above the cut-off frequency. Figure 29–29 shows an op-amp used as a band-pass filter. A band-pass filter passes frequencies around some central frequency while attenuating both higher and lower frequencies.

FIGURE 29–27
Op-amp connected as a high-pass filter.

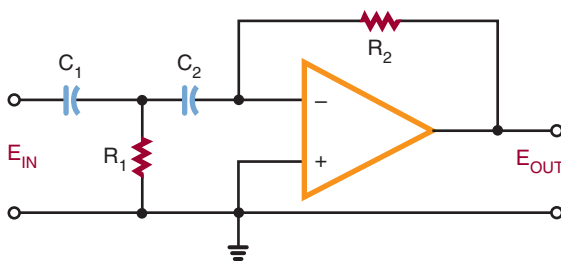


FIGURE 29–28
Op-amp connected as a low-pass filter.

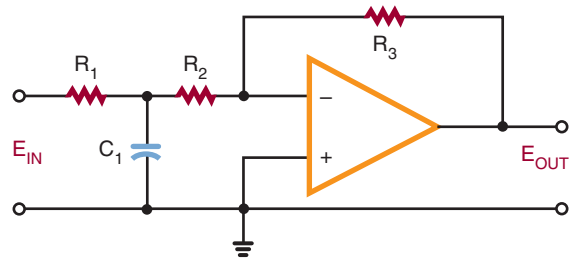


FIGURE 29–29
Op-amp connected as a band-pass filter.

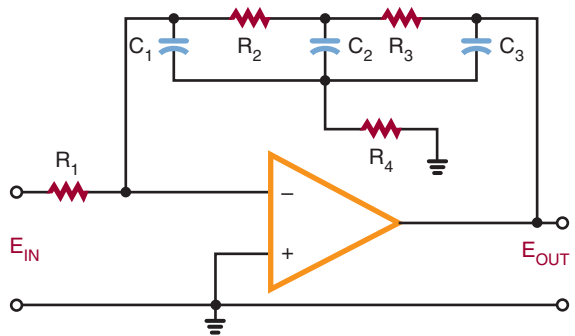
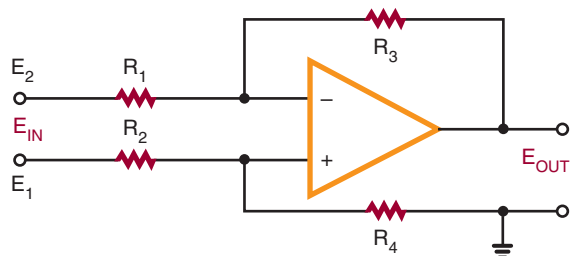


FIGURE 29–30
Op-amp connected as a difference amplifier.



A **difference amplifier** subtracts one signal from another signal. Figure 29–30 shows a basic difference amplifier. This circuit is called a *subtractor* because it subtracts the value of E_2 from the value of E_1 .

29-5 QUESTIONS

1. What is an op-amp?
2. Draw a block diagram of an op-amp.
3. Briefly explain how an op-amp works.
4. What is the normal mode of operation for an op-amp?
5. What type of gain can be obtained with an op-amp?
6. Draw schematic diagrams of the following:
 - a. Inverting amplifier
 - b. Summing amplifier
 - c. High-pass filter
 - d. Band-pass filter
 - e. Difference amplifier

SUMMARY

- Direct-coupled amplifiers are used primarily as voltage amplifiers.
- A differential amplifier has two separate inputs and may provide either one or two outputs.
- Audio amplifiers amplify AC signals in the audio range of 20 to 20,000 hertz.
- The two types of audio amplifiers are voltage amplifiers and power amplifiers.
- Video amplifiers are wideband amplifiers used to amplify video information.
- Video frequencies extend from a few hertz to 5 or 6 megahertz.
- RF amplifiers operate from 10,000 to 30,000 megahertz.
- The two types of RF amplifiers are tuned and untuned.
- Op-amps may provide output gains of 20,000 to 1,000,000 times the input.
- The two basic closed-loop modes are the inverting configuration and the noninverting configuration.

CHAPTER 29 SELF-TEST

1. Under what conditions would a DC amplifier be used?
2. How is the problem of temperature instability resolved with high-gain DC amplifiers?
3. What are the main differences between audio voltage amplifiers and audio power amplifiers?
4. What is the practical advantage of using a quasi-complementary power amplifier over a complementary push-pull amplifier?
5. How does a video amplifier differ from an audio amplifier?
6. What factor is involved in limiting the output of high-frequency video amplifiers?
7. What is the purpose of an RF amplifier?
8. How are IF amplifiers used in a circuit?
9. Identify the three stages of an op-amp, and describe its function.
10. For what type of application is the op-amp used?

Oscillators

OBJECTIVES

After completing this chapter, the student should be able to:

- Describe an oscillator and its purpose.
- Identify the main requirements of an oscillator.
- Explain how a tank circuit operates and describe its relationship to an oscillator.
- Draw a block diagram of an oscillator.
- Identify LC, crystal, and RC sinusoidal oscillator circuits.
- Identify nonsinusoidal relaxation oscillator circuits.
- Draw examples of sinusoidal and nonsinusoidal oscillators.

An oscillator is a nonrotating device for producing alternating current. Oscillators are used extensively in the field of electronics: in radios and televisions, communication systems, computers, industrial controls, and timekeeping devices. Without the oscillator, very few electronic circuits would be possible.



See accompanying CD for interactive presentations, tutorials, and DC Circuit examples in MultiSim, Chapter 30.

30-1 FUNDAMENTALS OF OSCILLATORS

An **oscillator** is a circuit that generates a repetitive AC signal. The frequency of the AC signal may vary from a few hertz to many millions of hertz. The oscillator is an alternative to the mechanical generator used to produce electrical power. The advantages of the oscillator are the absence of moving parts and the range over which the AC signal can be produced. The output of an oscilla-

tor may be a sinusoidal, rectangular, or sawtooth waveform, depending on the type of oscillator used. The main requirement of an oscillator is that the output be uniform; that is, the output must not vary in either frequency or amplitude.

When an inductor and a capacitor are connected in parallel, they form what is called a **tank circuit**. When a tank circuit is excited by an external DC source, it oscillates; that is, it produces a back-and-forth current flow. If it were not for the resistance of the circuit, the tank circuit would os-

cillate forever. However, the resistance of the tank circuit absorbs energy from the current, and the oscillations of the circuit are dampened.

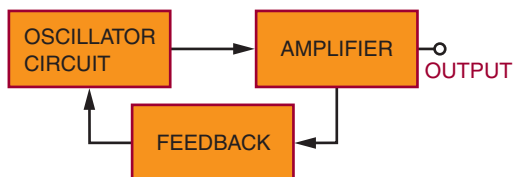
For the tank circuit to maintain its oscillation, the energy that is dissipated must be replaced. The energy that is replaced is referred to as **positive feedback**. Positive feedback is the feeding back into the tank circuit of a portion of the output signal to sustain oscillation. The feedback must be in phase with the signal in the tank circuit.

Figure 30–1 shows a block diagram of an oscillator. The basic oscillator can be broken down into three sections. The frequency-determining oscillator circuit is usually an LC tank circuit. An amplifier increases the output signal of the tank circuit. A feedback circuit delivers the proper amount of energy to the tank circuit to sustain oscillation. The oscillator circuit is essentially a closed loop that uses DC power to maintain AC oscillations.

30–1 QUESTIONS

1. What is an oscillator?
2. How does a tank circuit operate?
3. What makes a tank circuit continue to oscillate?
4. Draw and label a block diagram of an oscillator.
5. What are the functions of the basic parts of an oscillator?

FIGURE 30–1
Block diagram of an oscillator.



30–2 SINUSOIDAL OSCILLATORS

Sinusoidal oscillators are oscillators that produce a sine-wave output. They are classified according to their frequency-determining components. The three basic types of sinusoidal oscillators are LC oscillators, crystal oscillators, and RC oscillators.

LC oscillators use a tank circuit of capacitors and inductors, connected either in series or parallel, to determine the frequency. Crystal oscillators are like LC oscillators except that crystal oscillators maintain a higher degree of stability. LC and crystal oscillators are used in the radio frequency (RF) range. They are not suitable for low-frequency applications. For low-frequency applications, RC oscillators are used. RC oscillators use a resistance-capacitance network to determine the oscillator frequency.

Three basic types of LC oscillator are the Hartley oscillator, the Colpitts oscillator, and the Clapp oscillator. Figures 30–2 and 30–3 show the two basic types of Hartley oscillator. The tapped inductor in the tank circuit identifies these circuits as Hartley oscillators. The disadvantage of the series-fed Hartley (Figure 30–2) is that DC current

FIGURE 30–2
Series-fed Hartley oscillator.

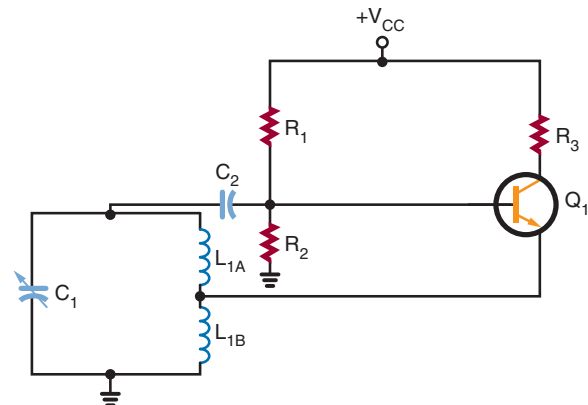


FIGURE 30-3
Shunt-fed Hartley oscillator.

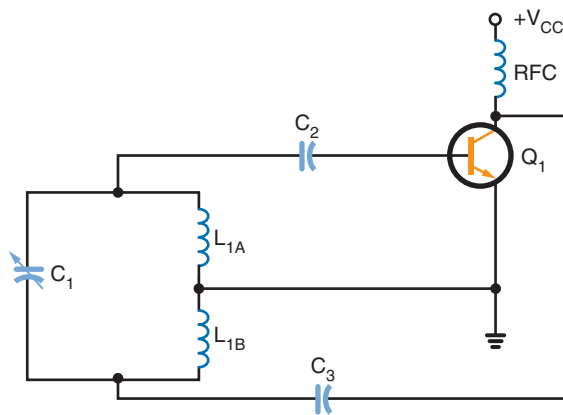
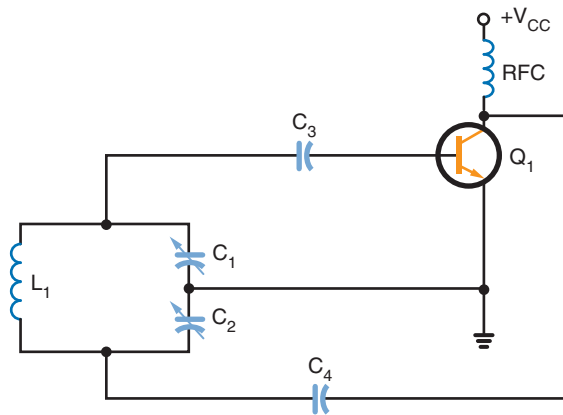


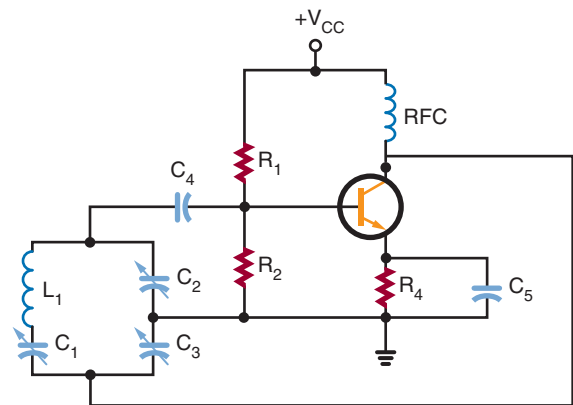
FIGURE 30-4
Colpitts oscillator.



flows through a portion of the tank circuit. The shunt-fed Hartley (Figure 30-3) overcomes the problem of DC current in the tank circuit by using a coupling capacitor in the feedback line.

The Colpitts oscillator (Figure 30-4) is like the shunt-fed Hartley except that two capacitors are substituted for the tapped inductor. The Colpitts is more stable than the Hartley and is more often used.

FIGURE 30-5
Clapp oscillator.



The Clapp oscillator (Figure 30-5) is a variation of the Colpitts oscillator. The main difference is the addition of a capacitor in series with the inductor in the tank circuit. The capacitor allows tuning of the oscillator frequency.

Temperature changes, aging of components, and varying load requirements cause oscillators to become unstable. When stability is a requirement, crystal oscillators are used.

Crystals are materials that can convert mechanical energy to electrical energy when pressure is applied or can convert electrical energy to mechanical energy when a voltage is applied. When an AC voltage is applied to a crystal, the crystal stretches and compresses, creating mechanical vibrations that correspond to the frequency of the AC signal.

Crystals, because of their structure, have a natural frequency of vibration. If the AC signal applied matches the natural frequency, the crystal vibrates more. If the AC signal is different from the crystal's natural frequency, little vibration is produced. The crystal's mechanical frequency of vibration is constant, making it ideal for oscillator circuits.

The most common materials used for crystals are Rochelle salt, tourmaline, and quartz. Rochelle salt has the most electrical activity, but it fractures easily. Tourmaline has the least electrical activity, but it is the strongest. Quartz is a compromise: It has good electrical activity and is strong. Quartz is the most commonly used crystal in oscillator circuits.

The crystal material is mounted between two metal plates, with pressure applied by a spring so that the metal plates make electrical contact with the crystal. The crystal is then placed in a metal package. Figure 30-6 shows the schematic symbol used to represent the crystal. The letters *Y* or *XTAL* identify crystals in schematics.

FIGURE 30-6
Schematic symbol for crystal.

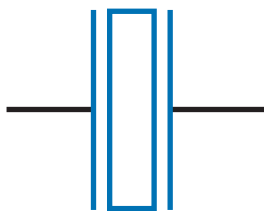


FIGURE 30-7
Crystal shunt-fed Hartley oscillator.

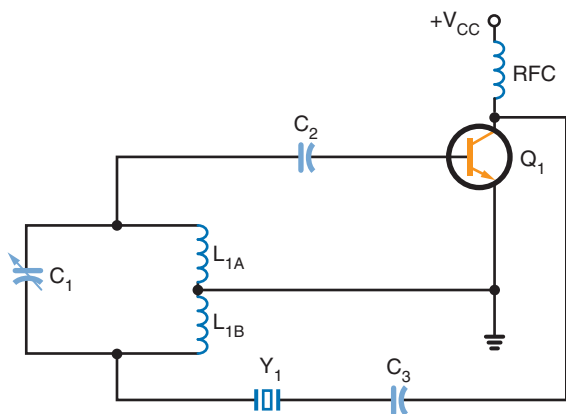


FIGURE 30-8
Colpitts crystal oscillator.

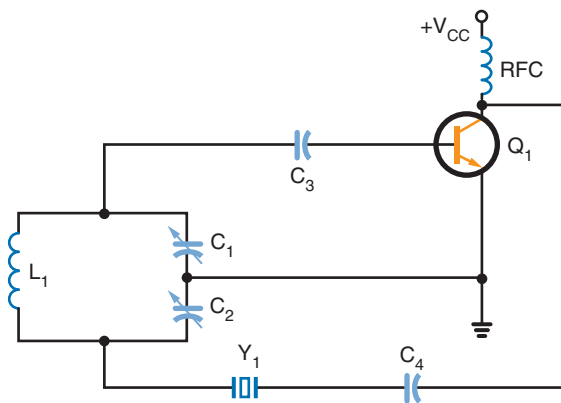


Figure 30-7 shows a shunt-fed Hartley oscillator with the addition of a crystal. The crystal is connected in series with the feedback circuit. If the frequency of the tank circuit drifts from the crystal frequency, the impedance of the crystal increases, reducing feedback to the tank circuit. This allows the tank circuit to return to crystal frequency.

Figure 30-8 shows a Colpitts oscillator connected the same way as the Hartley crystal oscillator. The crystal controls the feedback to the tank circuit. The LC tank circuit is tuned to the crystal frequency.

Figure 30-9 shows a Pierce oscillator. This circuit is similar to the Colpitts oscillator except that the tank-circuit inductor is replaced with a crystal. The crystal controls the tank-circuit impedance, which determines the feedback and stabilizes the oscillator.

Figure 30-10 shows a Butler oscillator. This is a two-transistor circuit. It uses a tank circuit, and the crystal determines the frequency. The tank circuit must be tuned to the crystal frequency or the oscillator does not work. The advantage of the Butler oscillator is that a small voltage exists across the crystal, reducing stress on the crystal.

FIGURE 30-9

Pierce oscillator.

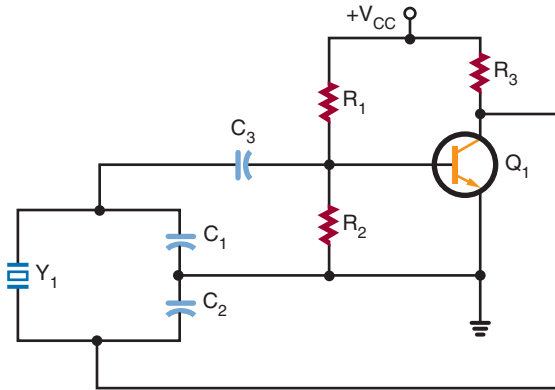
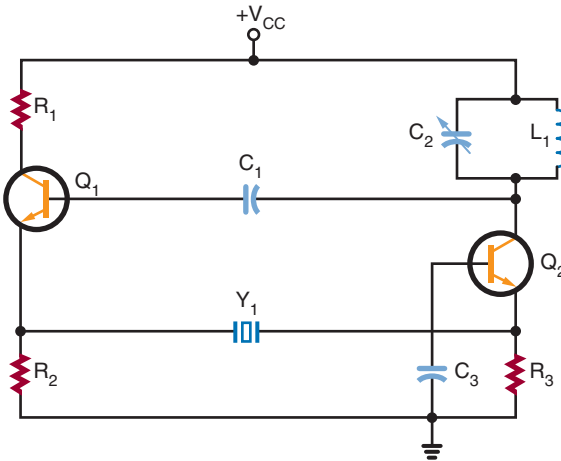


FIGURE 30-10

Butler oscillator.

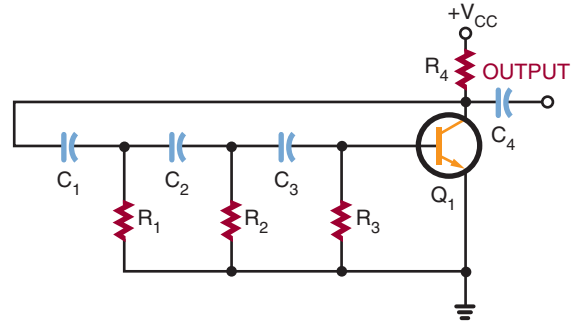


By replacing the tank-circuit components, the oscillator can be tuned to operate on one of the crystal's overtone frequencies.

RC oscillators use resistance-capacitance networks to determine the oscillator frequency. There are two basic types of RC oscillators that produce sinusoidal waveforms: the phase-shift oscillator and the Wien-bridge oscillator.

FIGURE 30-11

Phase-shift oscillator.



A *phase-shift oscillator* is a conventional amplifier with a phase-shifting RC feedback network (Figure 30-11). The feedback must shift the signal 180 degrees. Because the capacitance reactance changes with a change in frequency, it is the frequency-sensitive component. Stability is improved by reducing the amount of phase shift across each RC network. However, there is a power loss across the combined RC network. The transistor must have enough gain to offset these losses.

A *Wien-bridge oscillator* is a two-stage amplifier with a lead-lag network and voltage divider (Figure 30-12). The lead-lag network consists of a series RC network (R_1 C_1) and a parallel network. It is called a *lead-lag network* because the output phase angle leads for some frequencies and lags for other frequencies. At the resonant frequency, the phase shift is zero, and the output voltage is maximum. Resistors R_3 and R_4 form the voltage-divider network, which is used to develop the degenerative feedback. *Regenerative feedback* is applied to the base and *degenerative feedback* is applied to the emitter of oscillator transistor Q_1 . The output of transistor Q_1 is capacitively coupled to the base of transistor Q_2 where it is amplified and shifted and required 180 degrees. The output is coupled by capacitor C_3 to the bridge network.

FIGURE 30–12

Wien-bridge oscillator.

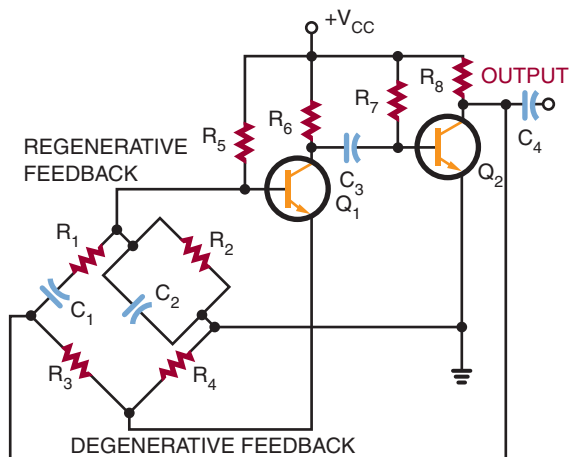


FIGURE 30–13

IC Wien-bridge oscillator.

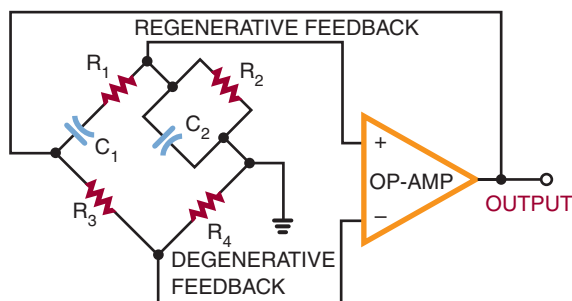


Figure 30–13 shows an integrated circuit Wien-bridge oscillator. The inverting and noninverting inputs of the op-amp are ideal for use as a Wien-bridge oscillator. The gain of the op-amp is high, which offsets the circuit losses.

30–2 QUESTIONS

1. What are the three types of sinusoidal oscillators?
2. Draw and label schematic diagrams of the three types of LC oscillators.

3. What is the difference between a Colpitts oscillator and a Hartley oscillator?
4. How can the stability of an LC oscillator be improved? ★
5. What are the two types of RC oscillators used for producing sinusoidal waves?

30–3 NONSINUSOIDAL OSCILLATORS

Nonsinusoidal oscillators are oscillators that do not produce a sine-wave output. There is no specific nonsinusoidal waveshape. The nonsinusoidal oscillator output may be a square, sawtooth, rectangular, or triangular waveform, or a combination of two waveforms. A common characteristic of all nonsinusoidal oscillators is that they are a form of relaxation oscillator. A **relaxation oscillator** stores energy in a reactive component during one phase of the oscillation cycle and gradually releases the energy during the relaxation phase of the cycle.

Blocking oscillators and *multivibrators* are relaxation oscillators. Figure 30–14 shows a blocking oscillator circuit. The reason for the name is that the transistor is easily driven into the blocking (cut-off) mode. The blocking condition is determined by the discharge from capacitor C_1 . Capacitor C_1 is charged through the emitter-base junction of transistor Q_1 . However, once capacitor

FIGURE 30–14

Blocking oscillator.

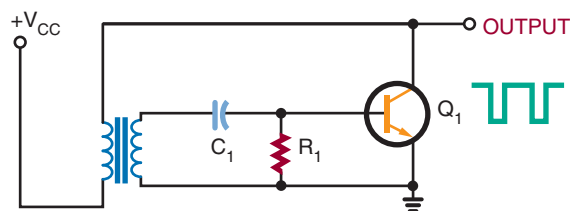
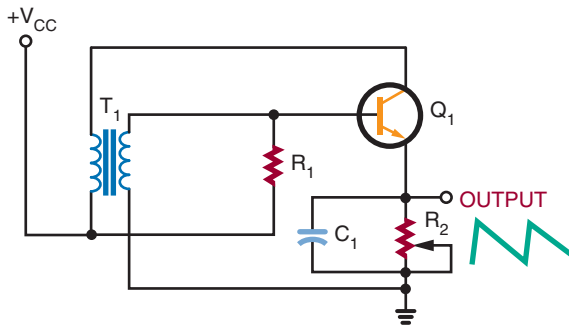


FIGURE 30-15

Sawtooth waveform generated by a blocking oscillator.



C_1 is charged, the only discharge path is through resistor R_1 . The RC time constant of resistor R_1 and capacitor C_1 determines how long the transistor is blocked or cut off and also determines the oscillator frequency. A long time constant produces a low frequency; a short time constant produces a high frequency.

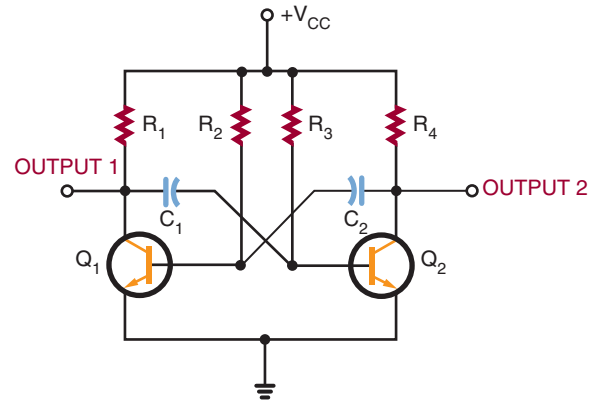
If the output is taken from an RC network in the emitter circuit of the transistor, the output is a sawtooth waveshape (Figure 30-15). The RC network determines the frequency of oscillation and produces the sawtooth output. Transistor Q_1 is forward biased by resistor R_1 . As transistor Q_1 conducts, capacitor C_1 charges quickly. The positive potential on the top plate of capacitor C_1 reverse biases the emitter junction, turning off transistor Q_1 . Capacitor C_1 discharges through resistor R_2 , producing the trailing portion of the sawtooth output. When capacitor C_1 discharges, transistor Q_1 is again forward biased and conducts, repeating the action.

Capacitor C_1 and resistor R_2 determine the frequency of oscillation. By making resistor R_2 variable, the frequency can be adjusted. If resistor R_2 offers high resistance, a long RC time constant results, producing a low frequency of oscillation. If resistor R_2 offers low resistance, a short RC time constant results, producing a high frequency of oscillation.

A **multivibrator** is a relaxation oscillator that can function in either of two temporarily stable con-

FIGURE 30-16

Free-running multivibrator.



ditions and is capable of rapidly switching from one temporary state to the other.

Figure 30-16 shows a basic free-running multivibrator circuit. It is basically an oscillator consisting of two stages coupled so that the input signal to each stage is taken from the output of the other. One stage conducts while the other stage is cut off, until a point is reached where the stages reverse their conditions. The circuit is free-running because of regenerative feedback. The frequency of oscillation is determined by the coupling circuit.

An **astable multivibrator** is one type of free-running multivibrator. The output of an astable multivibrator is rectangular. By varying the RC time constants of the coupling circuits, rectangular pulses of any desired width can be obtained. By changing the values of the resistor and capacitor, the operating frequency can be changed. The frequency stability of the multivibrator is better than that of the typical blocking oscillator.

An integrated circuit that can be used as an astable multivibrator is the 555 timer (Figure 30-17). This integrated circuit can perform many functions. It consists of two comparators, a flip-flop, an output stage, and a discharge transistor. Figure 30-18 shows a schematic diagram in

FIGURE 30-17

Block diagram of a 555 timer integrated circuit.

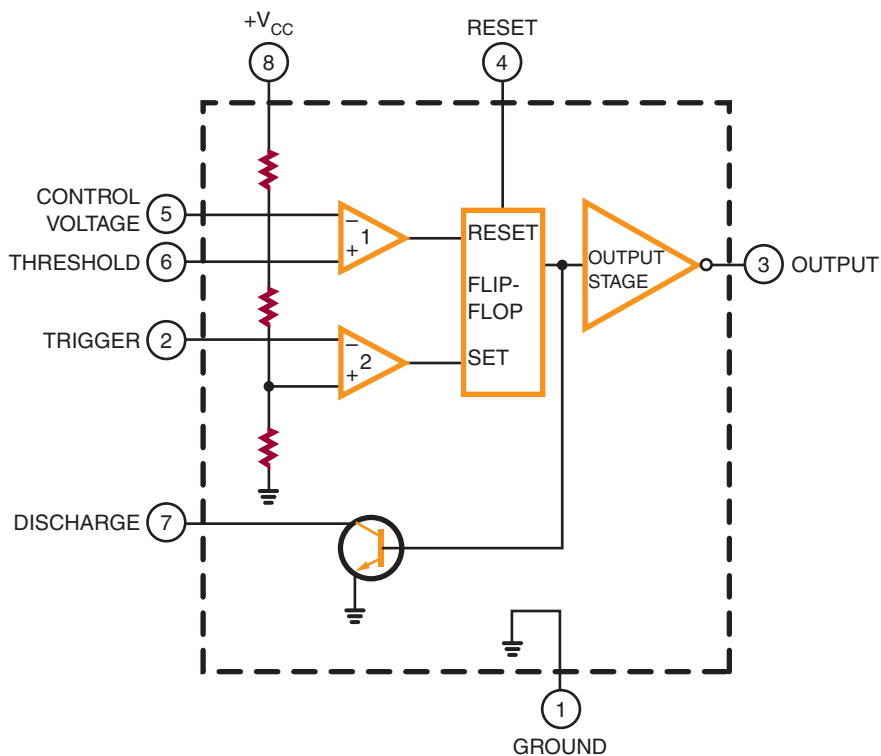
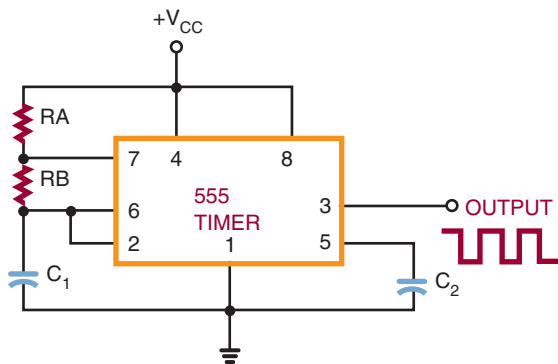


FIGURE 30-18

Astable multivibrator using a 555 timer.



which the 555 timer is used as an astable multivibrator. The output frequency is determined by resistors R_A and R_B and capacitor C_1 . This circuit finds wide application in industry.

30-3 QUESTIONS

1. Draw the more commonly used nonsinusoidal waveforms.
2. What is a relaxation oscillator?
3. Give two examples of relaxation oscillators.

4. Draw a schematic diagram of a blocking oscillator.
5. Draw a schematic diagram of a 555 timer used as an astable multivibrator.

SUMMARY

- An oscillator is a nonrotating device for producing alternating current.
 - The output of an oscillator can be sinusoidal, rectangular, or sawtooth.
 - The main requirement of an oscillator is that the output be uniform and not vary in frequency or amplitude.
 - A tank circuit is formed when a capacitor is connected in parallel with an inductor.
 - A tank circuit oscillates when an external voltage source is applied.
 - The oscillations of a tank circuit are dampened by the resistance of the circuit.
 - For a tank circuit to maintain oscillation, positive feedback is required.
- An oscillator has three basic parts: a frequency-determining device, an amplifier, and a feedback circuit.
 - The three basic types of sinusoidal oscillators are LC oscillators, crystal oscillators, and RC oscillators.
 - The three basic types of LC oscillators are the Hartley, the Colpitts, and the Clapp.
 - Crystal oscillators provide more stability than LC oscillators.
 - RC oscillators use resistance-capacitance networks to determine the oscillator frequency.
 - Nonsinusoidal oscillators do not produce a sine-wave output.
 - Nonsinusoidal oscillator outputs include square, sawtooth, rectangular, and triangular waveforms and combinations of two waveforms.
 - A relaxation oscillator is the basis of all nonsinusoidal oscillators.
 - A relaxation oscillator stores energy in a reactive component during one part of the oscillation cycle.
 - Examples of relaxation oscillators are blocking oscillators and multivibrators.

CHAPTER 30 SELF-TEST

1. Identify the parts of an oscillator, and explain what each part does in making the oscillator function.
2. Explain how a tank circuit can sustain an oscillation.
3. What are the major types of sinusoidal oscillators?
4. How are crystals used in oscillator circuits?
5. How does a nonsinusoidal oscillator differ from a sinusoidal oscillator?
6. What types of components make up nonsinusoidal oscillators?

Waveshaping Circuits

OBJECTIVES

After completing this chapter, the student should be able to:

- Identify ways in which waveform shapes can be changed.
- Explain the frequency-domain concept in waveform construction.
- Define *pulse width*, *duty cycle*, *rise and fall time*, *undershoot*, *overshoot*, and *ringing* as they relate to waveforms.
- Explain how differentiators and integrators work.
- Describe clipper and clamper circuits.
- Describe the differences between monostable and bistable multivibrators.
- Draw schematic diagrams of waveshaping circuits.

In electronics it is sometimes necessary to change the shape of a waveform. Sine waves may need to be changed to square waves, rectangular waveforms may need to be changed to pulse waveforms, and pulse waveforms may need to be changed to square or rectangular waveforms. Waveforms can be analyzed by two methods. Analyzing a waveform by its amplitude per unit of time is called a *time-domain analysis*. Analyzing a waveform by the sine waves that make it up is called a *frequency-domain analysis*. This concept assumes that all periodic waveforms are composed of sine waves.



See accompanying CD for Waveshaping Circuit examples in MultiSim, Chapter 31.

31-1 NONSINUSOIDAL WAVEFORMS

Figure 31-1 shows three basic waveforms that are represented by the **time domain** concept. The three waveforms shown are sine wave, square

wave, and sawtooth wave. Although the three waveforms are different, they all have the same period of frequency. By using various electronic circuits, these waveforms can be changed from one shape to another.

FIGURE 31-1

Three basic waveforms: (A) sine wave, (B) square wave, (C) sawtooth wave.

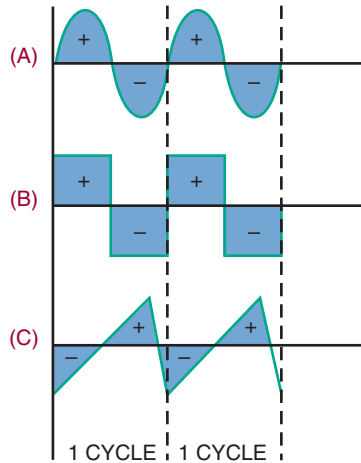


FIGURE 31-2

Chart of fundamental frequency of 1000 hertz and some of its harmonics.

(Fundamental)	1st Harmonic	1000 Hz
	2nd Harmonic	2000 Hz
	3rd Harmonic	3000 Hz
	4th Harmonic	4000 Hz
	5th Harmonic	5000 Hz

A *periodic waveform* is one with the same waveform for all cycles. According to the **frequency domain concept**, all periodic waveforms are made up of sine waves. In other words, any periodic wave can be formed by superimposing a number of sine waves having different amplitudes, phases, and frequencies. Sine waves are important because they are the only waveform that cannot be distorted by RC, RL, or LC circuits.

The sine wave that has the same frequency as the periodic waveform is called the *fundamental frequency*. The fundamental frequency is also called the *first harmonic*. **Harmonics** are multiples of

FIGURE 31-3

Square wave.

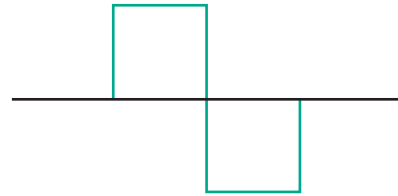
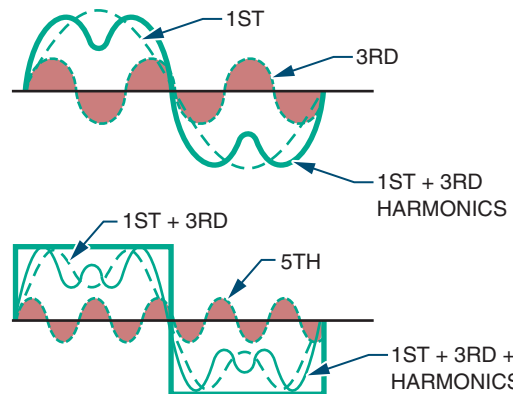


FIGURE 31-4

Formation of a square wave by the frequency domain method.



the fundamental frequency. The second harmonic is twice the fundamental, the third harmonic is three times the fundamental, and so on. Figure 31-2 shows the fundamental frequency of 1000 hertz and some of its harmonics. Harmonics can be combined in an infinite number of ways to produce any periodic waveform. The type and number of harmonics included in the periodic waveform depend on the shape of the waveform.

For example, Figure 31-3 shows a square wave. Figure 31-4 shows how a square wave is formed by the combination of the fundamental frequency with an infinite number of odd harmonics that cross the zero reference line in phase with the fundamental.

FIGURE 31-5

Formation of a sawtooth wave by the frequency domain method.

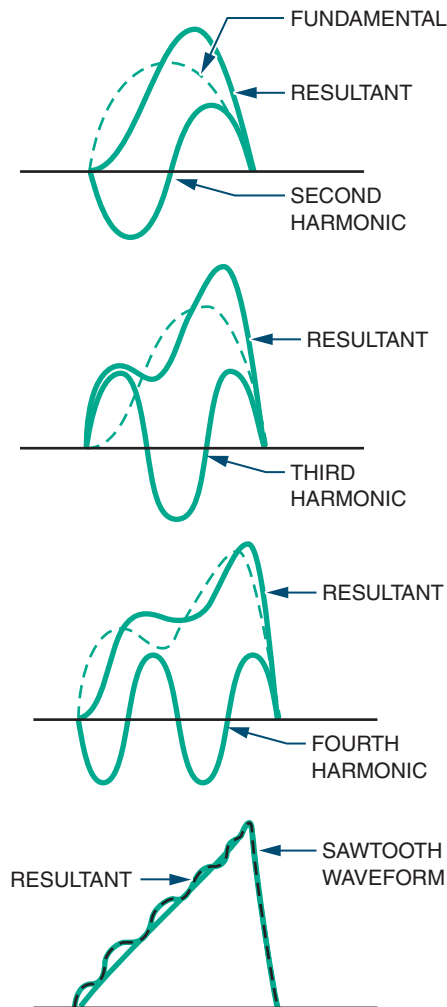
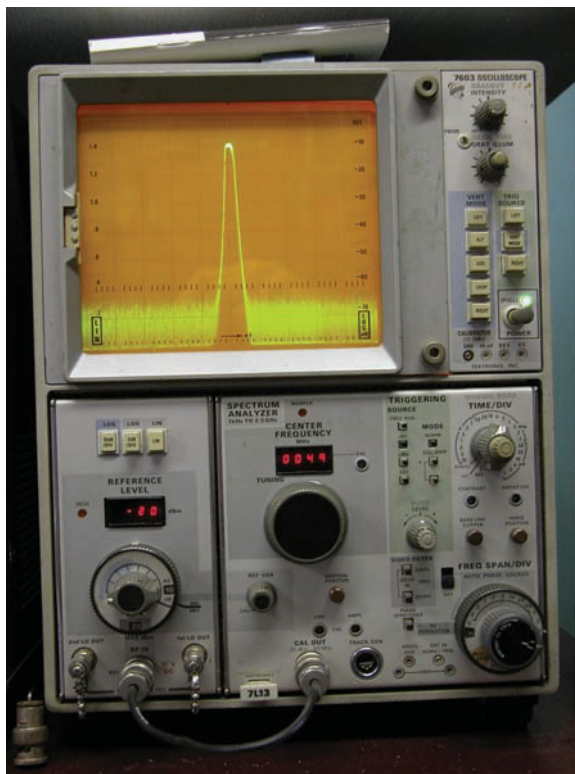


Figure 31-5 shows the formation of a sawtooth waveform. It consists of the fundamental frequency plus odd harmonics in-phase and even harmonics crossing the zero reference line 180 degrees out of phase with the fundamental.

An oscilloscope displays waveforms in the time domain. A *spectrum analyzer* (Figure 31-6)

FIGURE 31-6

Spectrum analyzer.



displays waveforms in the frequency domain. Frequency domain analysis can be used to determine how a circuit affects a waveform.

Periodic waveforms are waveforms that occur at regular intervals. The *period* of a waveform is measured from any point on one cycle to the same point on the next cycle (Figure 31-7).

The **pulse width** is the length of the pulse (Figure 31-8). The **duty cycle** is the ratio of the pulse width to the period. It can be represented as a percentage indicating the amount of time that the pulse exists during each cycle.

$$\text{duty cycle} = \frac{\text{pulse width}}{\text{period}}$$

All pulses have rise and fall times. The **rise time** is the time it takes from the pulse to rise from 10%

FIGURE 31-7

Period of a waveform.

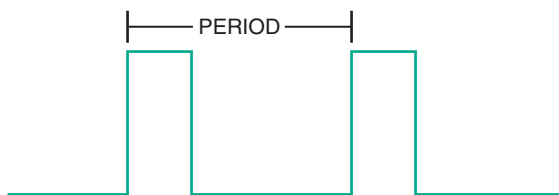


FIGURE 31-8

Pulse width of a waveform.

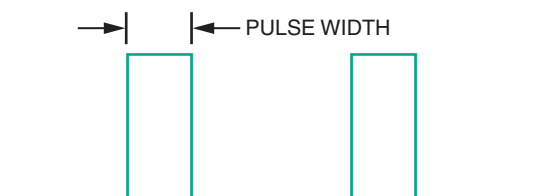
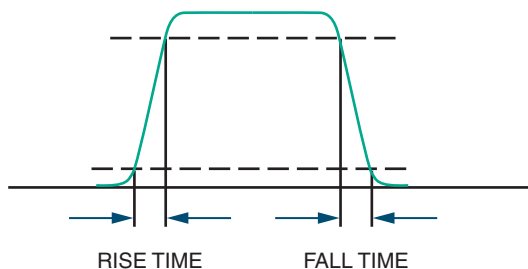


FIGURE 31-9

The rise and fall times of a waveform are measured at 10% and 90% of the waveform's maximum amplitude.

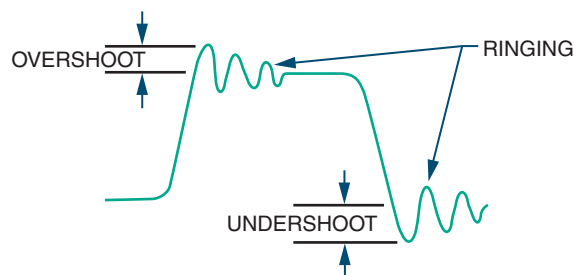


to 90% of its maximum amplitude. The **fall time** is the time it takes for a pulse to fall from 90% to 10% of its maximum amplitude (Figure 31-9).

Overshoot, undershoot, and ringing are conditions common to high-frequency pulses (Figure 31-10). *Overshoot* occurs when the leading edge of a waveform exceeds its normal maximum value. *Undershoot* occurs when the trailing edge exceeds its normal minimum value. (The **leading edge** is the

FIGURE 31-10

Overshoot, undershoot, and ringing.



front edge of the waveform; the **trailing edge** is the back edge of the waveform.) Both conditions are followed by damped oscillations known as *ringing*. These conditions are undesirable but exist because of imperfect circuits.

31-1 QUESTIONS

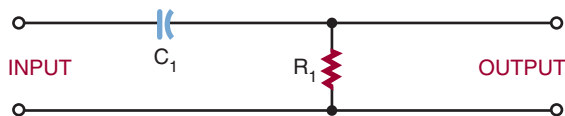
1. Define the *frequency domain* concept.
2. How are the following waveforms constructed according to the frequency domain concept?
 - a. Square wave
 - b. Sawtooth wave
3. What is a periodic waveform?
4. What is a duty cycle?
5. Draw examples of overshoot, undershoot, and ringing as they apply to a waveform.

31-2 WAVESHAPING CIRCUITS

An RC network can change the shape of complex waveforms so that the output barely resembles the input. The amount of distortion is determined by the RC time constant. The type of distortion is determined by the component the output is

FIGURE 31-11

Differentiator circuit.



taken across. If the output is taken across the resistor, the circuit is called a **differentiator**. A *differentiator* is used to produce a pip or peaked waveform from square or rectangular waveforms for timing or synchronizing circuits. It is also used to produce trigger or marker pulses. If the output is taken across the capacitor, the circuit is called an **integrator**. An integrator is used for waveshaping in radio, television, radar, and computers.

Figure 31-11 shows a differentiator circuit. Recall that complex waveforms are made of the fundamental frequency plus a large number of harmonics. When a complex waveform is applied to a differentiator, each frequency is affected differently. The ratio of the capacitive reactance (X_C) to R is different for each harmonic. This results in each harmonic being shifted in phase and reduced in amplitude by a different amount. The net result is distortion of the original waveform. Figure 31-12 shows what happens to a square wave applied to a differentiator. Figure 31-13 shows the effects of different RC time constants.

FIGURE 31-12

Result of applying a square wave to a differentiator circuit.

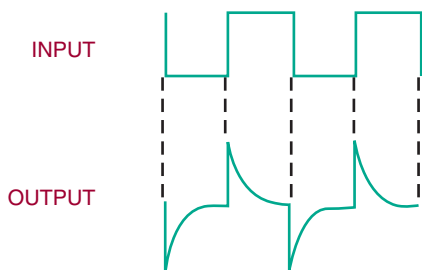


FIGURE 31-13

Effects of different time constants on a differentiator circuit.

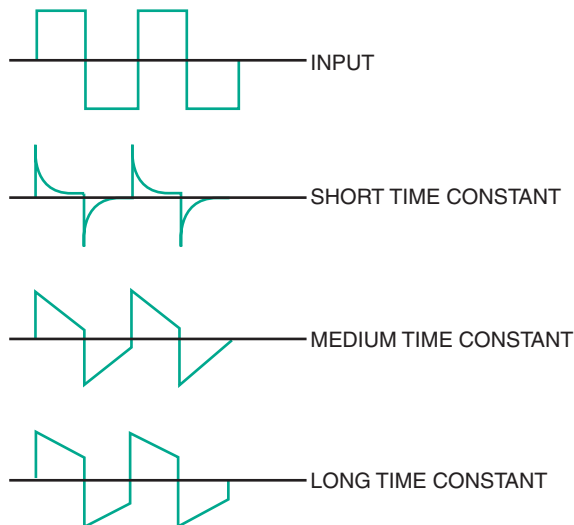


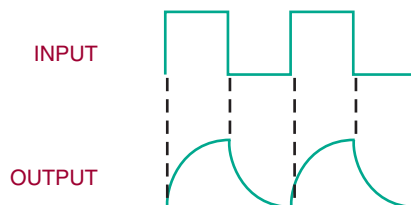
FIGURE 31-14

Integrator circuit.



FIGURE 31-15

Result of applying a square wave to an integrator circuit.



An integrator circuit is similar to a differentiator except that the output is taken across the capacitor (Figure 31-14). Figure 31-15 shows the result of applying a square wave to an integrator. The integrator changes the waveform in a differ-

FIGURE 31-16

Effects of different time constants on an integrator circuit.

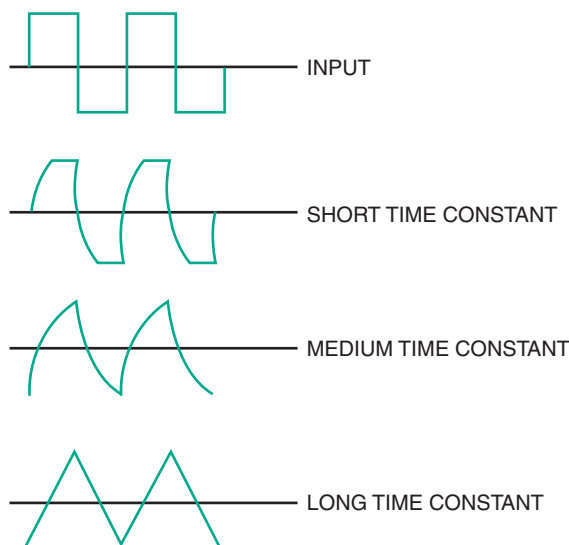
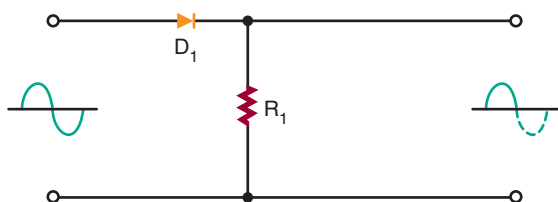


FIGURE 31-17

Basic series diode clipping circuit.



ent way than the differentiator. Figure 31-16 shows the effects of different RC time constants.

Another type of circuit that can change the shape of a waveform is a **clipping**, or **limiter circuit** (Figure 31-17). A clipping circuit can be used to square off the peaks of an applied signal, obtain a rectangular waveform from a sine-wave signal, eliminate positive or negative portions of a waveform, or keep an input amplitude at a constant level. The diode is forward biased and conducts during the positive portion of the input signal. During the negative portion of the input signal, the diode is reverse biased and does not conduct.

FIGURE 31-18

Result of reversing the diode in a clipping circuit.

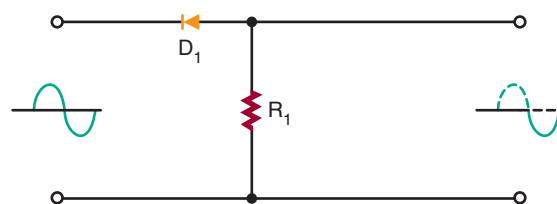


FIGURE 31-19

Biased series diode clipping circuit.

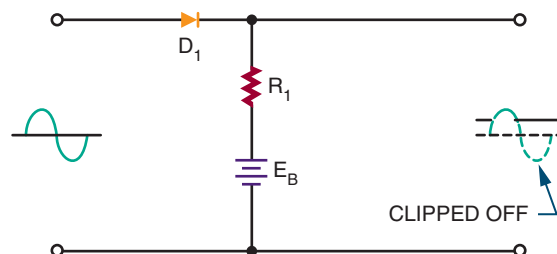


FIGURE 31-20

Result of reversing diode and bias source in a biased series clipping circuit.

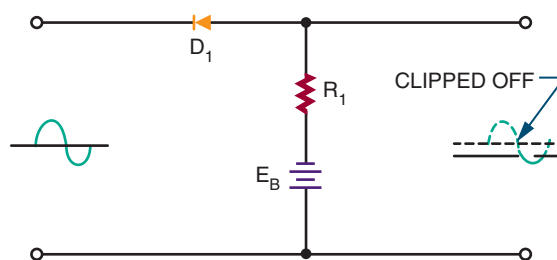


Figure 31-18 shows the effect of reversing the diode: The positive portion of the input signal is clipped off. The circuit is essentially a half-wave rectifier.

By using a bias voltage, the amount of signal that is clipped off can be regulated. Figure 31-19 shows a biased series clipping circuit. The diode cannot conduct until the input signal exceeds the bias source. Figure 31-20 shows the result of reversing the diode and the bias source.

FIGURE 31-21

Shunt diode clipping circuit.

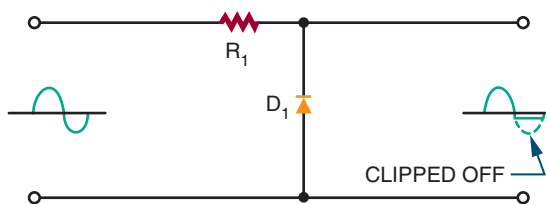


FIGURE 31-22

Result of reversing the diode in a shunt diode clipping circuit.

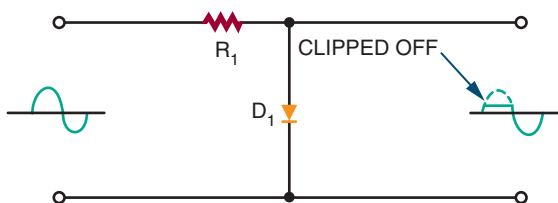
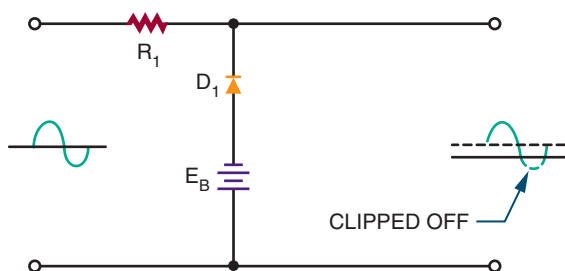


FIGURE 31-23

Biased shunt diode clipping circuit.



A shunt clipping circuit performs the same function as the series clipper (Figure 31-21). The difference is that the output is taken across the diode. This circuit clips off the negative portion of the input signal. Figure 31-22 shows the effect of reversing the diode. A shunt clipper can also be biased to change the clipping level as shown in Figures 31-23 and 31-24.

FIGURE 31-24

Effect of reversing the diode and bias source in a shunt diode clipping circuit.

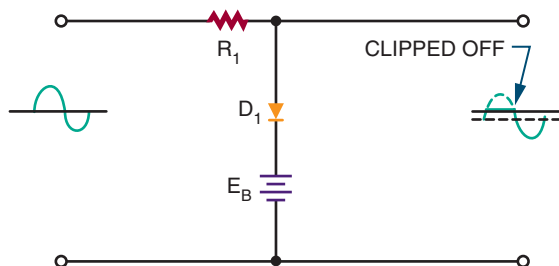
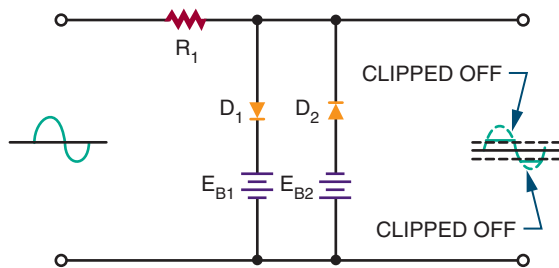


FIGURE 31-25

Clipping circuit used to limit both the positive and negative peaks.



If both the positive and the negative peaks must be limited, two biased diodes are used (Figure 31-25). This prevents the output signal from exceeding predetermined values for both peaks. With the elimination of both peaks, the remaining signal is generally square-shaped. Therefore, this circuit is often referred to as a square-wave generator.

Figure 31-26 shows another clipping circuit that limits both positive and negative peaks. Therefore, the output is clamped to the breakdown voltage of the zeners. Between the two extremes, neither zener diode will conduct, and the input signal is passed to the output.

Sometimes it is desirable to change the DC reference level of a waveform. The *DC reference level* is

FIGURE 31-26

Alternate circuit to limit both positive and negative peaks.

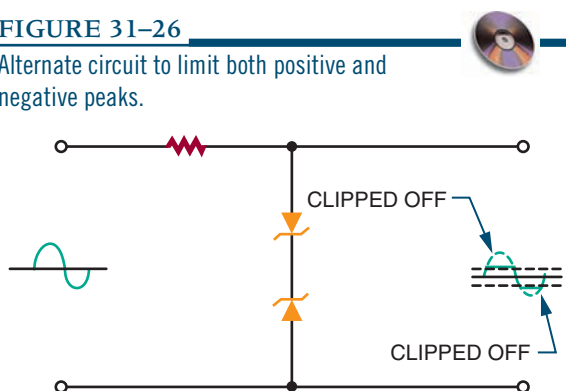
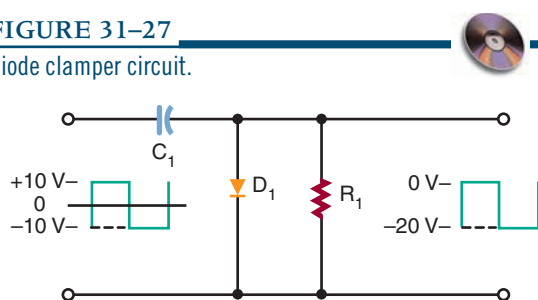


FIGURE 31-27

Diode clamper circuit.



the starting point from which measurements are made. A **clamping circuit** can be used to clamp the top or bottom of the waveform to a given DC voltage. Unlike a clipper or limiter circuit, a clamping circuit does not change the shape of the waveform. A diode clamper (Figure 31-27) is also called a DC restorer. This circuit is commonly used in radar, television, telecommunications, and computers. In the circuit shown, a square wave is applied to an input signal. The purpose of the circuit is to clamp the top of the square wave to 0 volts, without changing the shape of the waveform.

31-2 QUESTIONS

1. Draw schematic diagrams of the following RC networks:
 - a. Differentiator
 - b. Integrator

2. What are the functions of integrator and differentiator circuits?
3. Draw schematic diagrams of the following circuits:
 - a. Clipper
 - b. Clamper
4. What are the functions of clipper and clamper circuits?
5. What are applications of the following circuits:
 - a. Differentiator
 - b. Integrator
 - c. Clipper
 - d. Clamper

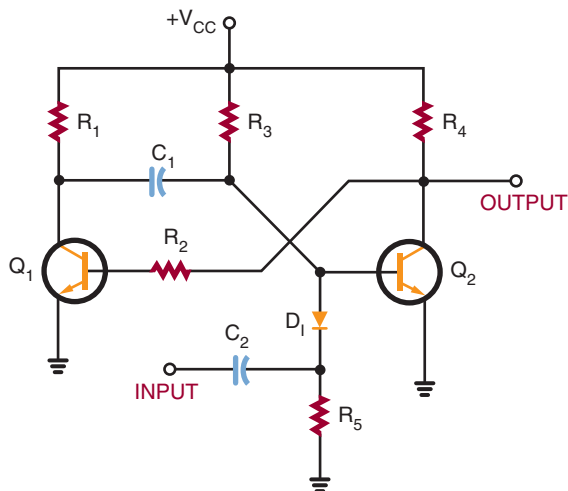
31-3 SPECIAL-PURPOSE CIRCUITS

The prefix *mono-* means *one*. A **monostable multivibrator** has only one stable state. It is also called a **one-shot multivibrator** because it produces one output pulse for each input pulse. The output pulse is generally longer than the input pulse. Therefore, this circuit is also called pulse stretcher. Typically, the circuit is used as a gate in computers, electronic control circuits, and communication equipment.

Figure 31-28 shows a schematic diagram of a monostable multivibrator. The circuit is normally in its stable state. When it receives an input trigger pulse, it switches to its unstable state. The length of time the circuit is in the unstable state is determined by the RC time constant of resistor R_2 and capacitor C_1 . Capacitor C_2 and resistor R_5 form a differentiator circuit, which is used to convert the input pulse to a positive and negative spike. Diode D_1 allows only the negative spike to pass through to turn on the circuit.

FIGURE 31–28

Monostable multivibrator.



A **bistable multivibrator** is a multivibrator having two stable states (*bi-* meaning *two*). This circuit requires two inputs to complete one cycle. A pulse at one input sets the circuit to one of its stable states. A pulse at the other input resets it to its other stable state. This circuit is often called a **flip-flop** because of its mode of operation (Figure 31–29).

A basic flip-flop circuit produces a square or rectangular waveform for use in gating or timing signals or for on-off switching operations in binary counter circuits. A binary counter circuit is essentially two transistor amplifiers with the output of each transistor coupled to the input of the other transistor. When an input signal is applied to the set input, transistor Q_1 turns on, which turns transistor Q_2 off. When transistor Q_2 turns off, it places a positive potential on the base of transistor Q_1 , holding it on. If a pulse is not applied to the reset input, it causes transistor Q_2 to conduct, turning off transistor Q_1 . Turning transistor Q_1 off holds transistor Q_2 on.

Discrete versions of the flip-flop find little application today. However, integrated circuit versions of the flip-flop find wide application. It is perhaps the most important circuit in digital elec-

FIGURE 31–29

Basic flip-flop circuit.

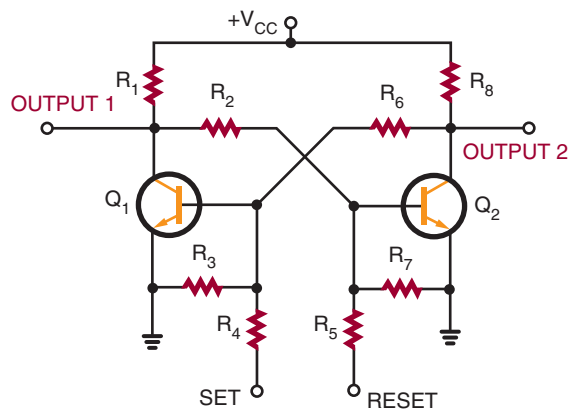
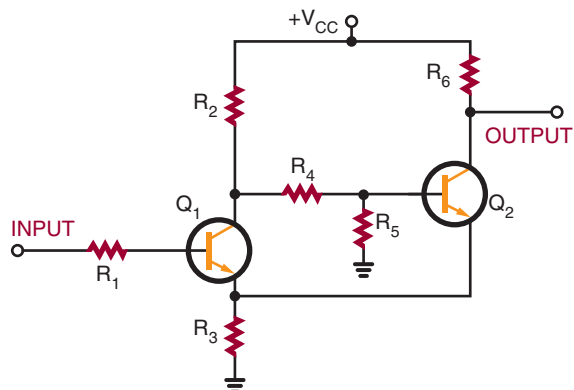


FIGURE 31–30

Basic Schmitt trigger circuit.



tronics, used for frequency division, data storage, counting, and data manipulation.

Another bistable circuit is the **Schmitt trigger** (Figure 31–30). One application of the Schmitt trigger is to convert a sine-wave, sawtooth, or other irregularly shaped waveform to a square or rectangular wave. The circuit differs from a conventional bistable multivibrator in that one of the coupling networks is replaced by a common-emitter resistor (R_3). This provides additional regeneration for quicker action and straighter leading and trailing edges on the output waveform.

31-3 QUESTIONS

1. What is a monostable multivibrator?
2. Draw a schematic diagram of a one-shot multivibrator.
3. What is a bistable multivibrator?
4. Draw a schematic diagram of a flip-flop.
5. How does a Schmitt trigger differ from a conventional bistable multivibrator?

SUMMARY

- Waveforms can be changed from one shape to another using various electronic circuits.
- The frequency domain concept holds that all periodic waveforms are made of sine waves.
- Periodic waveforms have the same waveshape in all cycles.
- Sine waves are the only waveform that cannot be distorted by RC, RL, or LC circuits.
- According to the frequency domain concept, waveforms consist of the fundamental frequency plus combinations of even or odd harmonics, or both.
- A square wave consists of the fundamental plus an infinite number of odd harmonics.
- A sawtooth wave consists of the fundamental plus even and odd harmonics crossing the zero reference line 180 degrees out of phase with the fundamental.
- Periodic waveforms are measured from any point on a cycle to the same point on the next cycle.
- The pulse width is the length of the pulse.
- The duty cycle is the ratio of the pulse width to the period.
- The rise time of a pulse is the time it takes to fall from 10% to 90% of its maximum amplitude.
- The fall time of a pulse is the time it takes to fall from 90% to 10% of its maximum amplitude.
- Overshoot, undershoot, and ringing are undesirable in a circuit and exist because of imperfect circuits.
- An RC circuit can be used to change the shape of a complex waveform.
- If the output is taken across the resistor in an RC circuit, the circuit is called a differentiator.
- If the output is taken across the capacitor in an RC circuit, the circuit is called an integrator.
- Clipping circuits are used to square off the peaks of an applied signal or to keep an amplitude constant.
- Clamping circuits are used to clamp the top or bottom of a waveform to a DC voltage.
- A monostable multivibrator (one-shot multivibrator) produces one output pulse for each input pulse.
- Bistable multivibrators have two stable states and are called flip-flops.
- A Schmitt trigger is a special-purpose bistable multivibrator.

CHAPTER 31 SELF-TEST

1. Describe the frequency domain concept of waveforms.
2. Why do such problems as overshoot, undershoot, and ringing occur in waveshaping circuits?
3. Describe where integrator and differentiator waveshaping circuits are used.

4. How can the DC reference level of a signal be changed?
5. Explain the difference between monostable and bistable circuit functions.
6. Of what significance is the flip-flop?

SECTION 4 ACTIVITY—LINEAR ELECTRONIC CIRCUITS

1. Build an electronic circuit such as the one shown in the back of the lab manual. Break the circuit down into basic circuits. Write a description of how the device works using own words. Use MultiSIM to help explain how the circuit works.
2. Design and build an electronic circuit that will blink lights and/or emit sound. Verify the circuit's operation with MultiSIM prior to building the circuit.
3. Design and build an audio amplifier that has a minimum gain of 100. Verify the circuit's operation using MultiSIM.

SECTION 5

Digital Electronic Circuits



Career Profile

Raymond L. Rickman



TITLE

Instructor of Electro-Mechanical Design and Drafting and Chairman of the Manufacturing and Technology Department

INSTITUTION

Okaloosa-Walton College

BACKGROUND

Ray became interested in the field of design and drafting while serving in the U.S. Air Force. After being honorably discharged, he pursued an Associate of Science degree in Design and Drafting with a specialization in the areas of electronics and mechanical design. Upon graduation he secured a position with an engineering firm and worked full-time in his field for six years. During this time, Ray pursued and completed both the Bachelor's and Master's degrees in Technical Education. His experience on the job coupled with his graduate degree helped him secure a position on the faculty of Okaloosa-Walton College (OWC) teaching electromechanical design and drafting. In addition to teaching, Ray is also Chairman of the Manufacturing and Technology Department at OWC, which includes programs in electronics, computer networking, graphic design, and drafting and design.

JOB REQUIREMENTS

Associate of Science degree in electromechanical drafting and Bachelor's degree in Technical Education in order to be a college-level instructor; Master's degree required in order to be a department chairman.

ON THE JOB

A typical day for Ray involves teaching several electromechanical design and drafting classes, providing counseling and academic advising for students majoring in electromechanical design and drafting, grading student work, assisting graduates in finding jobs in this field, recruiting new students for his program, participating in various committee meetings that are part of his duties as a faculty member and administrator, supervising faculty members who report to him, developing course schedules, doing the research and reading necessary to stay up-to-date in his field, and interacting with design and drafting professionals who act as advisors for his program.

In addition to teaching electromechanical design and drafting, Ray continues to work as a consultant in this field for various companies. His consulting activities help him stay in touch with employers and up-to-date with the latest developments in his field.

UPSIDE

Ray enjoys teaching because he knows that he is helping people make a better life for themselves and their families. He also knows that he is helping provide well-educated, highly skilled employees for engineering and manufacturing companies who hire electromechanical design and drafting technicians.

DOWNSIDE

Being both an instructor and a department chair sometimes involves long hours. It also means that Ray must do everything other faculty members do as well as his administrative duties.

OPPORTUNITIES

There are many opportunities for instructors in the fields of electronic design and drafting and electromechanical design and drafting, especially at community colleges and technical schools—both public and private. Being a technical instructor requires an individual to have qualifications in both the desired technical field and the field of education. Opportunities abound for those who take the time to acquire both sets of qualifications.

WORDS OF ADVICE

First build a strong background in electronics during your studies in technical school or community college. This will be the foundation for all of your other studies that will build on your technical certificate or associate degree. Then, continue to study electronics for a lifetime so that your knowledge is never outdated.

Binary Number System

OBJECTIVES

After completing this chapter, the student should be able to:

- Describe the binary number system.
- Identify the place value for each bit in a binary number.
- Convert binary numbers to decimal numbers.
- Convert decimal numbers to binary numbers.
- Convert decimal numbers to 8421 BCD code.
- Convert 8421 BCD code numbers to decimal numbers.

A number system is nothing more than a code. For each distinct quantity, there is an assigned symbol. When the code is learned, counting can be accomplished. This leads to arithmetic and higher forms of mathematics.

The simplest number system is the **binary number system**. The binary system contains only two digits, 0 and 1. These digits have the same value as in the decimal number system.

The binary number system is used in digital and microprocessor circuits because of its simplicity. Binary data are represented by binary digits, called **bits**. The term *bit* is derived from *binary digit*.

32-1 BINARY NUMBERS

The decimal system is called a base-10 system because it contains ten digits, 0 through 9. The binary system is a base-two system because it contains two digits, 0 and 1. The position of the 0 or 1 in a binary number indicates its value within the number. This is referred to as its place value

or weight. The place value of the digits in a binary number increases by powers of two.

	Place Value					
	32	16	8	4	2	1
Power of 2:	2^5	2^4	2^3	2^2	2^1	2^0

Counting in binary starts with the numbers 0 and 1. When each digit has been used in the 1s

place, another digit is added in the 2s place and the count continues with 10 and 11. This uses up all combinations of two digits, so a third digit is added in the 4's place and the count continues with 100, 101, 110, and 111. Now a fourth digit is needed in the 8's place to continue, and so on. Figure 32-1 shows the binary counting sequence.

To determine the largest value that can be represented by a given number of places in base 2, use the following formula:

$$\text{Highest number} = 2^n - 1$$

where: n represents the number of bits (or number of place values used)

EXAMPLE: Two bits (two place values) can be used to count from 0 to 3 because:

$$2^n - 1 = 2^2 - 1 = 4 - 1 = 3$$

Four bits (four place values) are needed to count from 0 to 15 because:

$$2^n - 1 = 2^4 - 1 = 16 - 1 = 15$$

32-1 QUESTIONS

1. What is the advantage of the binary number system over the decimal number system for digital circuits?
2. How is the largest value of a binary number determined for a given number of place values?
3. What is the maximum value of a binary number with:
 - a. 4 bits
 - b. 8 bits
 - c. 12 bits
 - d. 16 bits

FIGURE 32-1

Decimal number and equivalent binary table.

Decimal Number	Binary Number				
	2 ⁴ 16	2 ³ 8	2 ² 4	2 ¹ 2	2 ⁰ 1
0	0	0	0	0	0
1	0	0	0	0	1
2	0	0	0	1	0
3	0	0	0	1	1
4	0	0	1	0	0
5	0	0	1	0	1
6	0	0	1	1	0
7	0	0	1	1	1
8	0	1	0	0	0
9	0	1	0	0	1
10	0	1	0	1	0
11	0	1	0	1	1
12	0	1	1	0	0
13	0	1	1	0	1
14	0	1	1	1	0
15	0	1	1	1	1
16	1	0	0	0	0
17	1	0	0	0	1
18	1	0	0	1	0
19	1	0	0	1	1
20	1	0	1	0	0
21	1	0	1	0	1
22	1	0	1	1	0
23	1	0	1	1	1
24	1	1	0	0	0
25	1	1	0	0	1
26	1	1	0	1	0
27	1	1	0	1	1
28	1	1	1	0	0
29	1	1	1	0	1
30	1	1	1	1	0
31	1	1	1	1	1

32-2 BINARY AND DECIMAL CONVERSION

As stated, a binary number is a weighted number with a place value. The value of a binary number can be determined by adding the product of each digit and its place value. The method for evaluating a binary number is shown by the following example:

EXAMPLE:

	32	16	8	4	2	1
Binary number:	1	0	1	1	0	1
Value:	$1 \times 32 = 32$	$0 \times 16 = 0$	$1 \times 8 = 8$	$1 \times 4 = 4$	$0 \times 2 = 0$	$+ 1 \times 1 = 1$
	$101101_2 = 45_{10}$					

The number 45 is the decimal equivalent of the binary number 101101.

Fractional numbers can also be represented in binary form by placing digits to the right of the binary zero point, just as decimal numbers are placed to the right of the decimal zero point. All digits to the right of the zero point have weights that are negative powers of two, or fractional place values.

Power of 2	Place value
$2^5 = 32$	
$2^4 = 16$	
$2^3 = 8$	
$2^2 = 4$	
$2^1 = 2$	
$2^0 = 1$	

decimal point

$$2^{-1} = \frac{1}{2^1} = \frac{1}{2} = 0.5$$

$$2^{-2} = \frac{1}{2^2} = \frac{1}{4} = 0.25$$

$$2^{-3} = \frac{1}{2^3} = \frac{1}{8} = 0.125$$

$$2^{-4} = \frac{1}{2^4} = \frac{1}{16} = 0.0625$$

EXAMPLE: Determine the decimal value of the binary number 111011.011.

Binary number	Place value	Value
1	$\times 32$	$= 32$
1	$\times 16$	$= 16$
1	$\times 8$	$= 8$
0	$\times 4$	$= 0$
1	$\times 2$	$= 2$
1	$\times 1$	$= 1$
0	$\times 0.5$	$= 0$
1	$\times 0.25$	$= 0.25$
<u>+ 1</u>	<u>$\times 0.125$</u>	<u>$= 0.125$</u>
111011.011_2		$= 59.375_{10}$

In working with digital equipment, it is often necessary to convert from binary to decimal form and vice versa. The most popular way to convert decimal numbers to binary numbers is to progressively divide the decimal number by 2, writing down the remainder after each division. The remainders, taken in reverse order, form the binary number.

EXAMPLE: To convert 11_{10} to a binary number, progressively divide by 2 (LSB = least significant bit).

$$\begin{array}{r}
 11 \div 2 = 5 \text{ with a remainder of } 1 \\
 5 \div 2 = 2 \text{ with a remainder of } 1 \\
 2 \div 2 = 1 \text{ with a remainder of } 0 \\
 1 \div 2 = 0 \text{ with a remainder of } 1
 \end{array}
 \begin{array}{l}
 \text{LSB} \\
 \downarrow \\
 \downarrow \\
 \downarrow
 \end{array}$$

($1/2 = 0$ means that 2 will no longer divide into 1, so 1 is the remainder.) Decimal 11 is equal to 1011 in binary.

The process can be simplified by writing the numbers in an orderly fashion as shown for converting 25_{10} to a binary number.

EXAMPLE:

$$\begin{array}{r}
 2 \ 25 \\
 2 \ 12 \ 1 \\
 2 \ 6 \ 0 \\
 2 \ 3 \ 0 \\
 2 \ 1 \ 1 \\
 0 \ 1
 \end{array}
 \begin{array}{l}
 \text{LSB} \\
 \downarrow \\
 \downarrow \\
 \downarrow \\
 \downarrow \\
 \downarrow
 \end{array}$$

Decimal number 25 is equal to binary number 11001.

Fractional numbers are done a little differently: The number is multiplied by 2 and the carry is recorded as the binary fraction.

EXAMPLE: To convert decimal 0.85 to a binary fraction, progressively multiply by 2.

$$\begin{array}{l}
 0.85 \times 2 = 1.70 = 0.70 \text{ with a carry of } 1 \\
 0.70 \times 2 = 1.40 = 0.40 \text{ with a carry of } 1 \\
 0.40 \times 2 = 0.80 = 0.80 \text{ with a carry of } 0 \\
 0.80 \times 2 = 1.60 = 0.60 \text{ with a carry of } 1 \\
 0.60 \times 2 = 1.20 = 0.20 \text{ with a carry of } 1 \\
 0.20 \times 2 = 0.40 = 0.40 \text{ with a carry of } 0
 \end{array}
 \begin{array}{l}
 \text{LSB} \\
 \downarrow \\
 \downarrow \\
 \downarrow \\
 \downarrow \\
 \downarrow
 \end{array}$$

Continue to multiply by 2 until the needed accuracy is reached. Decimal 0.85 is equal to 0.110110 in binary form.

EXAMPLE: Convert decimal 20.65 to a binary number. Split 20.65 into an integer of 20 and a

fraction of 0.65 and apply the methods previously shown.

$$\begin{array}{r}
 2 \ 20 \\
 2 \ 10 \ 0 \\
 2 \ 5 \ 0 \\
 2 \ 2 \ 1 \\
 2 \ 1 \ 0 \\
 0 \ 1
 \end{array}
 \begin{array}{l}
 \text{LSB} \\
 \downarrow \\
 \downarrow \\
 \downarrow \\
 \downarrow \\
 \downarrow
 \end{array}$$

Decimal 20 = Binary 10100

and

$$\begin{array}{l}
 0.65 \times 2 = 1.30 = 0.30 \text{ with a carry of } 1 \\
 0.30 \times 2 = 0.60 = 0.60 \text{ with a carry of } 0 \\
 0.60 \times 2 = 1.20 = 0.20 \text{ with a carry of } 1 \\
 0.20 \times 2 = 0.40 = 0.40 \text{ with a carry of } 0 \\
 0.40 \times 2 = 0.80 = 0.80 \text{ with a carry of } 0 \\
 0.80 \times 2 = 1.60 = 0.60 \text{ with a carry of } 1 \\
 0.60 \times 2 = 1.20 = 0.20 \text{ with a carry of } 1
 \end{array}
 \begin{array}{l}
 \text{LSB} \\
 \downarrow \\
 \downarrow \\
 \downarrow \\
 \downarrow \\
 \downarrow \\
 \downarrow
 \end{array}$$

Decimal 0.65 = Binary 0.1010011

Combining the two numbers results in $20.65_{10} = 10100.1010011_2$. This 12-bit number is an approximation, because the conversion of the fraction was terminated after 7 bits.

32-2 QUESTIONS

1. What is the value of each position in an 8-bit binary number?
2. What is the value of each position to the right of the decimal point for 8 places?
3. Convert the following binary numbers to decimal numbers:
 - a. 1001
 - b. 11101111
 - c. 11000010

d. 10101010.1101

e. 10110111.0001

4. What is the process for converting decimal numbers to binary digits?
5. Convert the following decimal numbers to binary form:
 - a. 27
 - b. 34.6
 - c. 346
 - d. 321.456
 - e. 7465

32-3 BCD CODE

An *8421 code* is a **binary-coded-decimal (BCD)** code consisting of four binary digits. It is used to represent the digits 0 through 9. The *8421 designation* refers to the binary weight of the 4 bits.

Powers of 2: 2^3 2^2 2^1 2^0
 Binary weight: 8 4 2 1

The main advantage of this code is that it permits easy conversion between decimal and binary form. This is the predominant BCD code used and is the one referred to unless otherwise stated.

Each decimal digit (0 through 9) is represented by a binary combination as follows:

Decimal	8421 code
0	0000
1	0001
2	0010
3	0011
4	0100
5	0101
6	0110
7	0111
8	1000
9	1001

Although sixteen numbers (2^4) can be represented by four binary positions, the six code combinations above decimal 9 (1010, 1011, 1100, 1101, 1110, and 1111) are invalid in the 8421 code.

To express any decimal number in the 8421 code, replace each decimal digit by the appropriate 4-bit code.

EXAMPLE: Convert the following decimal numbers into a BCD code: 5, 13, 124, 576, 8769.

$$5 = 0101$$

$$13 = 0001\ 0011$$

$$124 = 0001\ 0010\ 0100$$

$$576 = 0101\ 0111\ 0110$$

$$8769 = 1000\ 0111\ 0110\ 1001$$

To determine a decimal number from an 8421 code number, break the code into groups of 4 bits. Then write the decimal digit represented by each 4-bit group.

EXAMPLE: Find the decimal equivalent for each of the following BCD codes: 10010101, 1001000, 1100111, 1001100101001, 1001100001110110.

$$1001\ 0101 = 95$$

$$0100\ 1000 = 48$$

$$0110\ 0111 = 67$$

$$0001\ 0011\ 0010\ 1001 = 1329$$

$$1001\ 1000\ 0111\ 0110 = 9876$$

Note: If there is an insufficient number of bits in the group furthest to the left, zeros are implied.

32-3 QUESTIONS

1. What is the 8421 code and how is it used?
2. Convert the following decimal numbers into BCD code:
 - a. 17
 - b. 100

c. 256

d. 778

e. 8573

3. Convert the following BCD codes into decimal numbers:

a. 1000 0010

b. 0111 0000 0101

c. 1001 0001 0011 0100

d. 0001 0000 0000 0000

e. 0100 0110 1000 1001

SUMMARY

- The binary number system is the simplest number system.
- The binary number system contains two digits, 0 and 1.
- The binary number system is used to represent data for digital and computer systems.

- Binary data are represented by binary digits called bits.
- The term *bit* is derived from *binary digit*.
- The place value of each higher digit's position in a binary number is increased by a power of 2.
- The largest value that can be represented by a given number of places in base 2 is $2^n - 1$, where n represents the number of bits.
- The value of a binary digit can be determined by adding the product of each digit and its place value.
- Fractional numbers are represented by negative powers of 2.
- To convert from a decimal number to a binary number, divide the decimal number by 2, writing down the remainder after each division. The remainders, taken in reverse order, form the binary number.
- The 8421 code, a binary-coded-decimal (BCD) code, is used to represent digits 0 through 9.
- The advantage of the BCD code is ease of converting between decimal and binary forms of a number.

CHAPTER 32 SELF-TEST

1. What represents the decimal equivalent of 0 through 27 in binary?
2. How many binary bits are required to represent the decimal number 100?
3. Describe the process for converting a decimal number to a binary number.
4. Convert the following binary numbers to their decimal equivalents.
 - a. 100101.001011
 - b. 111101110.11101110
 - c. 1000001.00000101
5. Describe the process for converting decimal numbers to BCD.
6. Convert the following BCD numbers to their decimal equivalents.
 - a. 0100 0001 0000 0110
 - b. 1001 0010 0100 0011
 - c. 0101 0110 0111 1000

Basic Logic Gates

OBJECTIVES

After completing this chapter, the student should be able to:

- Identify and explain the function of the basic logic gates.
- Draw the symbols for the basic logic gates.
- Develop truth tables for the basic logic gates.

All digital equipment, whether simple or complex, is constructed of only a few basic circuits. These circuits, referred to as *logic elements*, perform some logic function on binary data.

There are two basic types of logic circuits: decision-making and memory. *Decision-making logic circuits* monitor binary inputs and produce an output based on the status of the inputs and the characteristics of the logic circuit. *Memory circuits* are used to store binary data.



See accompanying CD for interactive presentations, tutorials, and DC Circuit examples in MultiSim, Chapter 33.

33-1 AND GATE

The **AND gate** is a logic circuit that has two or more inputs and a single output. The AND gate produces an output of 1, only when all its inputs are 1s. If any of the inputs are 0s, the output is 0.

Figure 33-1 shows the standard symbol used for AND gates. An AND gate can have any number of inputs greater than one. Shown in the figure are symbols representing the more commonly used gates of two, three, four, and eight inputs.

The operation of the AND gate is summarized by the table in Figure 33-2. Such a table, called a *truth table*, shows the output for each possible in-

put. The inputs are designated A and B. The output is designated Y. The total number of possible combinations in the truth table is determined by the following formula:

$$N = 2^n$$

where: N = the total number of possible combinations

n = the total number of input variables

EXAMPLE:

For two input variables, $N = 2^2 = 4$

For three input variables, $N = 2^3 = 8$

For four input variables, $N = 2^4 = 16$

For eight input variables, $N = 2^8 = 256$

FIGURE 33-1
Logic symbol for an AND gate.

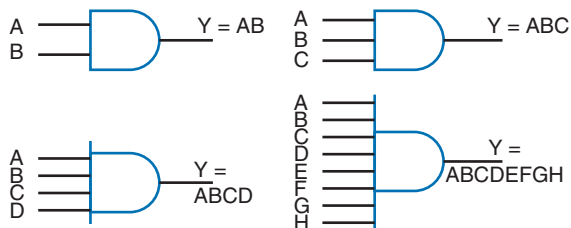


FIGURE 33-2
Truth table for a two-input AND gate.

INPUTS		OUTPUT
A	B	Y
0	0	0
1	0	0
0	1	0
1	1	1

The AND gate performs the basic operation of multiplication. Multiplication is known as the **AND** function. The output of an AND gate is represented by the equation $Y = A \cdot B$ or $Y = AB$. The AND function is represented by the dot between the two variables A and B.

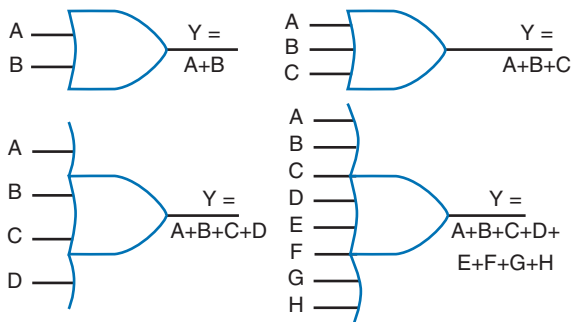
33-1 QUESTIONS

- Under what conditions does an AND gate produce a 1 output?
- Draw the symbol used to represent a two-input AND gate.
- Develop a truth table for a three-input AND gate.
- What logical operation is performed by an AND gate?
- What is the algebraic output of an AND gate?

FIGURE 33-3
Truth table for a two-input OR gate.

INPUTS		OUTPUT
A	B	Y
0	0	0
1	0	1
0	1	1
1	1	1

FIGURE 33-4
Logic symbol for an OR gate.



33-2 OR GATE

An **OR gate** produces a 1 output if any of its inputs are 1s. The output is a 0 if all the inputs are 0s. The output of a two-input OR gate is shown in the truth table in Figure 33-3. The total number of possible combinations is expressed by $N = 2^2 = 4$. The truth table shows all four combinations.

An OR gate performs the basic operation of addition. The algebraic expression for the output of an OR gate is $Y = A + B$. The plus sign designates the OR function.

Figure 33-4 shows the logic symbol for an OR gate. The inputs are labeled A and B, and the output is labeled Y. An OR gate can have any number of inputs greater than one. Shown in the figure are OR gates with two, three, four, and eight inputs.

33-2 QUESTIONS

1. What conditions produce a 1 output for an OR gate?
2. Draw the symbol used to represent a two-input OR gate.
3. Develop a truth table for a three-input OR gate.
4. What operation is performed by an OR gate?
5. What algebraic expression represents the output of an OR gate?

33-3 NOT GATE

The simplest logic circuit is the **NOT gate**. It performs the function called inversion, or complementation, and is commonly referred to as an *inverter*.

The purpose of the inverter is to make the output state the opposite of the input state. The two states associated with logic circuits are 1 and 0. A 1 state can also be referred to as a *high*, to indicate that the voltage is higher than in the 0 state. A 0 state can also be referred to as a *low*, to indicate that the voltage is lower than in the 1 state. If a 1, or high, is applied to the input of an inverter, a low, or 0, appears on its output. If a 0, or low, is applied to the input, a 1, or high, appears on its output.

The operation of an inverter is summarized in Figure 33-5. The input to an inverter is labeled A and the output is labeled \bar{A} (read “A NOT” or “NOT

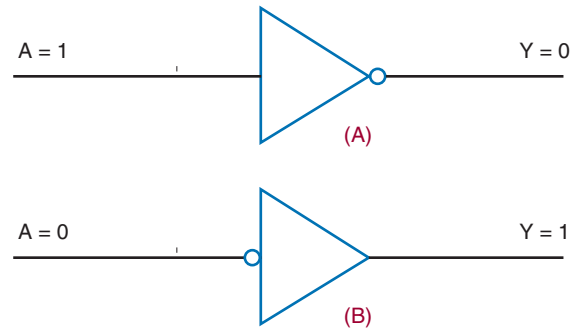
FIGURE 33-5

Truth table for an inverter.

INPUTS	OUTPUT
A	Y
0	1
1	0

FIGURE 33-6

Logic symbol for an inverter.



A”). The bar over the letter A indicates the complement of A. Because the inverter has only one input, only two input combinations are possible.

The symbol used to represent an inverter or NOT function is shown in Figure 33-6. The triangle portion of the symbol represents the circuit, and the circle or “bubble” represents the circuit inversion or complementary characteristic. The choice of symbol depends on where the inverter is used. If the inverter uses a 1 as the qualifying input, the symbol in Figure 33-6A is used. If the inverter uses a 0 as the qualifying input, the symbol in Figure 33-6B is used.

33-3 QUESTIONS

1. What operation is performed by a NOT circuit?
2. Develop a truth table for the NOT circuit.
3. Draw the symbols used to represent the NOT circuit.
4. Why are two different symbols used to represent the NOT circuit?

33-4 NAND GATE

A **NAND gate** is a combination of an inverter and an AND gate. It is called a NAND gate from the NOT-AND function it performs. The NAND gate is the

FIGURE 33-7
Logic symbol for an NAND gate.

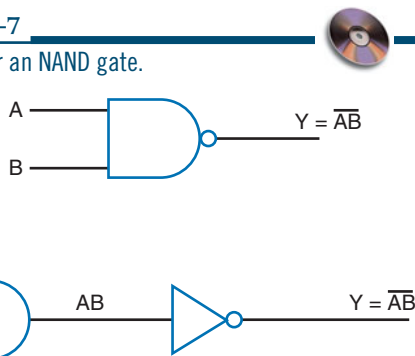


FIGURE 33-8
Truth table for a two-input NAND gate.

INPUTS		OUTPUT
A	B	Y
0	0	1
1	0	1
0	1	1
1	1	0

most commonly used logic function. This is because it can be used to construct an AND gate, OR gate, inverter, or any combination of these functions.

The logic symbol for a NAND gate is shown in Figure 33-7. Also shown is its equivalency to an AND gate and an inverter. The bubble on the output end of the symbol means to invert the AND function.

Figure 33-8 shows the truth table for a two-input NAND gate. Notice that the output of the NAND gate is the complement of the output of an AND gate. Any 0 in the input yields a 1 output.

The algebraic formula for NAND-gate output is $Y = \overline{AB}$, where Y is the output and A and B are the inputs. NAND gates are available with two, three, four, eight, and thirteen inputs.

NAND gates are the most widely available gates on the market. The availability and flexibility of the NAND gate allows it to be used for other

types of gates. Figure 33-9 shows how a NAND gate can be used to generate other logic functions.

33-4 QUESTIONS

1. What is a NAND gate?
2. Why is the NAND gate so often used in circuits?
3. Draw the logic symbol used to represent a NAND gate.
4. What is the algebraic expression for a NAND gate?
5. Develop a truth table for a three-input NAND gate.

33-5 NOR GATE

A **NOR gate** is a combination of an inverter and an OR gate. Its name derives from its NOT-OR function. Like the NAND gate, the NOR gate can also be used to construct an AND gate, an OR gate, and an inverter.

The logic symbol for the NOR gate is shown in Figure 33-10. Also shown is its equivalency to an OR gate and an inverter. The bubble on the output of the symbol means to invert the OR function.

Figure 33-11 shows the truth table for a two-input NOR gate. Notice that the output is the complement of the OR-function output. A 1 occurs only when 0 is applied to both inputs. A 1 input produces a 0 output.

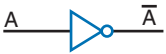


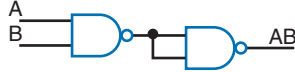

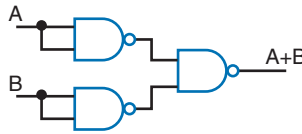

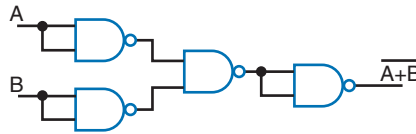

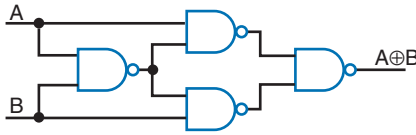

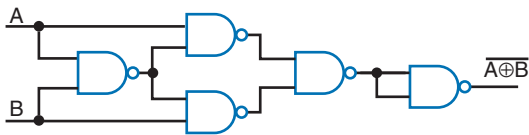
The algebraic expression for NOR-gate output is $Y = \overline{A + B}$, where Y is the output and A and B are the inputs. NOR gates are available with two, three, four, and eight inputs.

33-5 QUESTIONS

1. What is a NOR gate?
2. Why is the NOR gate useful in designing digital circuits?

FIGURE 33-9

Using the NAND gate to generate other logic functions.

LOGIC	LOGIC SYMBOL	LOGIC FUNCTIONS USING ONLY NAND GATES
INVERTER		
AND		
OR		
NOR		
XOR		
XNOR		

3. Draw the symbol used to represent a NOR gate.
4. What is the algebraic expression for a NOR gate?
5. Develop a truth table for a three-input NOR gate.

33-6 EXCLUSIVE OR AND NOR GATES

A less common but still important gate is called an **exclusive OR gate**, abbreviated as XOR. An XOR gate has only two inputs, unlike the OR gate, which may have several inputs. However, the XOR is similar to the OR gate in that it generates

FIGURE 33-10

Logic symbol for a NOR gate.

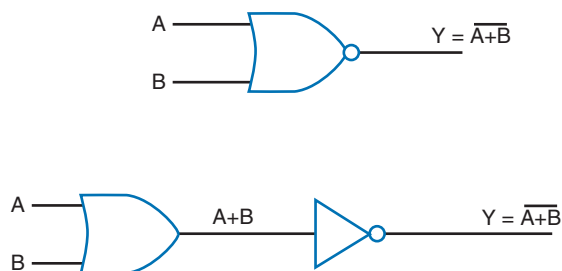


FIGURE 33-11

Truth table for a two-input NOR gate.

INPUTS		OUTPUT
A	B	Y
0	0	1
1	0	0
0	1	0
1	1	0

FIGURE 33-12

Logic symbol for an exclusive OR gate.



a 1 output if either input is a 1. The exclusive OR is different when both inputs are 1s or 0s. In that case, the output is a 0.

The symbol for an XOR gate is shown in Figure 33-12. Also shown is the equivalent logic circuit. Figure 33-13 shows the truth table for an exclusive OR gate. The algebraic output is written as $Y = A \oplus B$. It is read as “Y equals A exclusive or B.”

FIGURE 33-13

Truth table for an exclusive OR gate.

INPUTS		OUTPUT
A	B	Y
0	0	0
1	0	1
0	1	1
1	1	0

FIGURE 33-14

Logic symbol for an exclusive NOR gate.



FIGURE 33-15

Truth table for an exclusive NOR gate.

INPUTS		OUTPUT
A	B	Y
0	0	1
1	0	0
0	1	0
1	1	1

The complement of the XOR gate is the XNOR (**exclusive NOR**) gate. Its symbol is shown in Figure 33-14. The bubble on the output implies inversion or complement. Also shown is the equivalent logic circuit. Figure 33-15 shows the truth table for an exclusive NOR gate. The algebraic output is written as $Y = \overline{A \oplus B}$, read as “Y equals A exclusive nor B.”

33-6 QUESTIONS

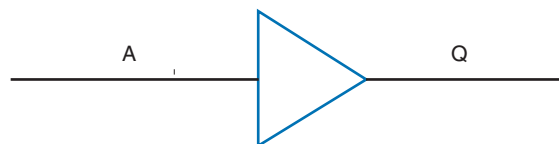
1. What is the difference between an OR gate and an XOR gate?
2. Draw the symbol used to represent an XOR gate.
3. Develop a truth table for an XOR gate.
4. Draw the symbol used to represent an XNOR gate.
5. Write the algebraic expressions for XOR and XNOR gates.

33-7 BUFFER

A buffer is a special logic gate that isolates conventional gates from other circuitry and provides a high driving current for heavy circuit loads or fan-out. Buffers provide noninverting input and output. A 1 in provides a 1 out and a 0 in provides a 0 out. Figure 33-16 shows the schematic symbol for a basic buffer with its truth table.

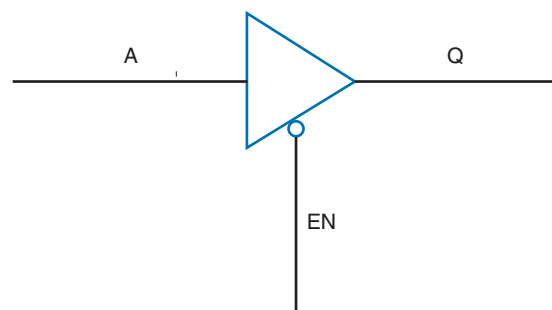
Another type of buffer is the 3-state buffer shown with its truth table in Figure 33-17. The

FIGURE 33-16
Logic symbol for a buffer.



Input	Output
A	Q
0	0
1	1

FIGURE 33-17
Logic symbol for a 3-state buffer.



Input		Output
A	EN	Q
0 or 1	0	0 or 1
0 or 1	1	No Output

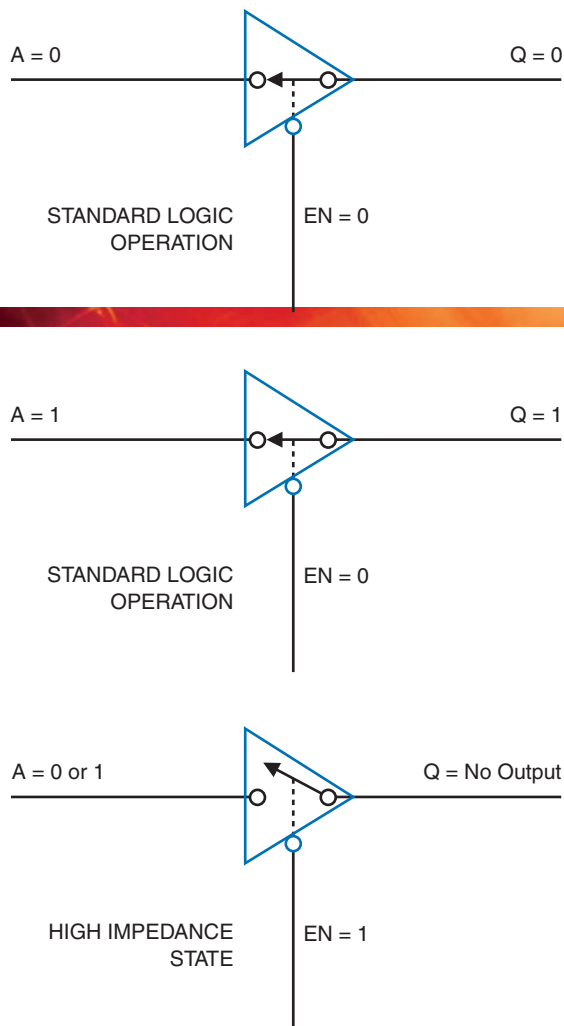
3-state buffer has the usual 1 and 0 output states but it also has a third state, which is referred to as a high-impedance state. This state provides an open circuit between the input circuitry and the output and is controlled by the EN line. The EN line represents an enable/disable control input. Figure 33-18 shows how the 3-state buffer operates.

33-7 QUESTIONS

1. How does a buffer differ from an inverter?
2. What function does a buffer serve?
3. Draw the symbol for a buffer and a 3-state buffer.
4. Develop a truth table for a 3-state buffer.
5. What conditions must exist for no output from a 3-state buffer?

FIGURE 33-18

3-state buffer operation.



SUMMARY

- An AND gate produces a 1 output when all of its inputs are 1s.
- An AND gate performs the basic operation of multiplication.
- An OR gate produces a 1 output if any of its inputs are 1s.
- An OR gate performs the basic operation of addition.
- A NOT gate performs the function called inversion or complementation.
- A NOT gate converts the input state to an opposite output state.
- A NAND gate is a combination of an AND gate and an inverter.
- A NAND gate produces 1 output when any of the inputs are 0s.
- A NOR gate is a combination of an OR gate and an inverter.
- A NOR gate produces a 1 output only when both inputs are 0s.
- An exclusive OR (XOR) gate produces a 1 output only if both inputs are different.
- An exclusive NOR (XNOR) gate produces a 1 output only when both inputs are the same.
- A buffer isolates conventional gates from other circuitry.
- A buffer provides a high current for heavy loads or fan-outs.
- A 3-state buffer has a high-impedance third state.

CHAPTER 33 SELF-TEST

1. Draw the schematic symbol for a six-input AND gate.
2. Develop the truth table for a four-input AND gate.
3. Draw the schematic symbol for a six-input OR gate.
4. Develop the truth table for a four-input OR gate.

5. What is the purpose for the NOT circuit?
6. How does an inverter for an input signal differ from the inverter for an output signal?
7. Draw the schematic symbol for an eight-input NAND gate.
8. Develop the truth table for a four-input NAND gate.
9. Draw the schematic symbol for an eight-input NOR gate.
10. Develop the truth table for a four-input NOR gate.
11. What is the significance of the XOR gate?
12. The XNOR gate has what maximum number of inputs?
13. Draw the schematic symbol for a buffer.
14. What purpose does the buffer serve?
15. Draw the schematic symbol for a 3-state buffer.

Simplifying Logic Circuits

OBJECTIVES

After completing this chapter, the student should be able to:

- Explain the function of Veitch diagrams.
- Describe how to use a Veitch diagram to simplify Boolean expressions.
- Explain the function of a Karnaugh map.
- Describe how to simplify a Boolean expression using a Karnaugh map.

Digital circuits are being used more and more in electronics, not only in computers, but also in applications such as measurement, automatic control, robotics, and in situations requiring decisions. All of these applications require complex switching circuits that are formed from the five basic logic gates: the AND, OR, NAND, and NOR gates and the inverter.

The significant point about these logic gates is that they only have two operating conditions. They are either ON (1) or OFF (0). When logic gates are interconnected to form more complex circuits, it is necessary to obtain the simplest circuit possible.

Boolean algebra offers a means of expressing complex switching functions in equation form. A Boolean expression is an equation that expresses the output of a logic circuit in terms of its input. Veitch diagrams and Karnaugh maps provide a fast and easy way to reduce a logic equation to its simplest form.

34-1 VEITCH DIAGRAMS

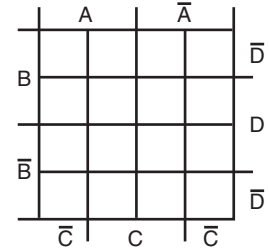
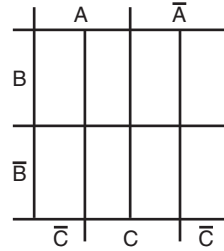
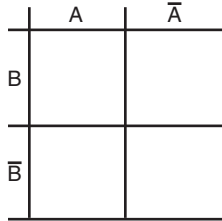
Veitch diagrams provide a fast and easy method for reducing a complicated expression to its simplest form. They can be constructed for two, three, or four variables. Figure 34-1 shows several Veitch diagrams.

To use a Veitch diagram, follow these steps, as illustrated in the example.

1. Draw the diagram based on the number of variables.
2. Plot the logic functions by placing an X in each square representing a term.
3. Obtain the simplified logic function by looping adjacent groups of X's in groups of

FIGURE 34-1

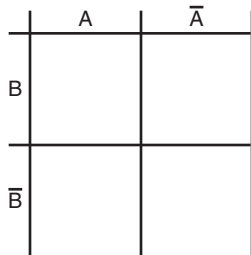
Two-, three-, and four-variable Veitch diagrams.



- eight, four, or two. Continue to loop until all X's are included in a loop.
4. "OR" the loops with one term per loop. (Each expression is pulled off the Veitch diagram and "OR"ed using the "+" symbol, e.g., $ABC + BCD$.)
 5. Write the simplified expression.

EXAMPLE: Reduce $AB + \bar{A}B + A\bar{B} = Y$ to its simplest form.

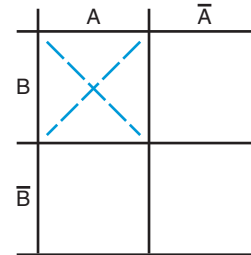
Step 1. Draw the Veitch diagram. There are two variables, A and B, so use the two-variable chart.



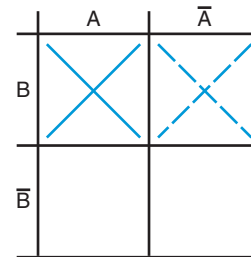
Step 2. Plot the logic function by placing an X in each square representing a term.

AB	+	$\bar{A}B$	+	$A\bar{B}$
1st		2nd		3rd
term		term		term

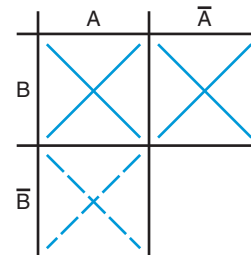
Plot 1st term AB



Plot 2nd term $\bar{A}B$

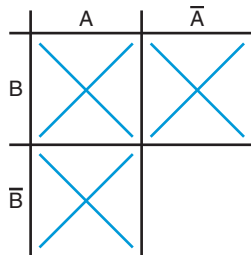


Plot 3rd term $A\bar{B}$

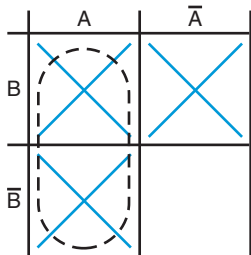


Step 3. Loop adjacent groups of X's in the largest group possible.

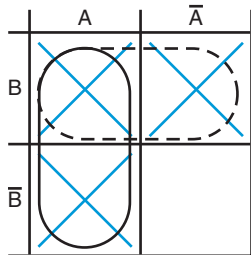
Start by analyzing chart for largest groups possible. The largest group possible here is two.



One possible group is the one indicated by the dotted line.



Another group is the one indicated by this dotted line.

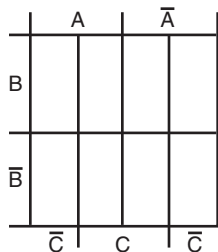


Step 4. "OR" the groups: either A or B = $A + B$

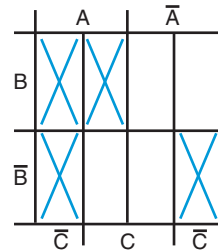
Step 5. The simplified expression for $AB + \bar{A}\bar{B} + \bar{A}B + A\bar{B} = Y$ is $A + B = Y$ obtained from the Veitch diagram.

EXAMPLE: Find the simplified expression for $ABC + ABC\bar{C} + A\bar{B}\bar{C} + \bar{A}\bar{B}\bar{C} = Y$

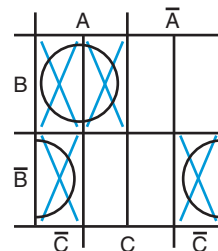
Step 1. Draw a three-variable Veitch diagram.



Step 2. Place an X for each term on the Veitch diagram.



Step 3. Loop the groups.



Step 4. Write the term for each loop, one term per expression:

$$AB, \bar{B}\bar{C}$$

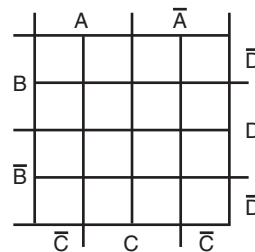
Step 5. The simplified expression is $AB + \bar{B}\bar{C} = Y$.

Notice the unusual looping on the two bottom squares. The four corners of the Veitch diagram are considered connected as if the diagram were formed into a ball.

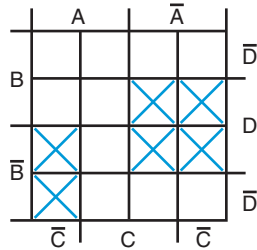
EXAMPLE: Find the simplified expression for:

$$\bar{A}\bar{B}CD + \bar{A}\bar{B}\bar{C}D + \bar{A}\bar{B}\bar{C}\bar{D} + A\bar{B}\bar{C}\bar{D} + A\bar{B}C\bar{D} + \bar{A}\bar{B}C\bar{D} = Y$$

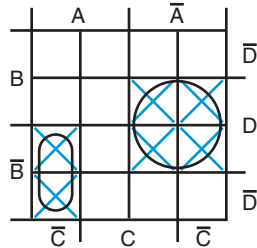
Step 1. Draw a four-variable Veitch diagram.



Step 2. Place an X for each term on the Veitch diagram.



Step 3. Loop the groups.



Step 4. Write the term for each loop, one term per expression: $\bar{A}D$, $A\bar{B}\bar{C}$

Step 5. "OR" the terms to form the simplified expression: $\bar{A}D + A\bar{B}\bar{C} = Y$

34-1 QUESTIONS

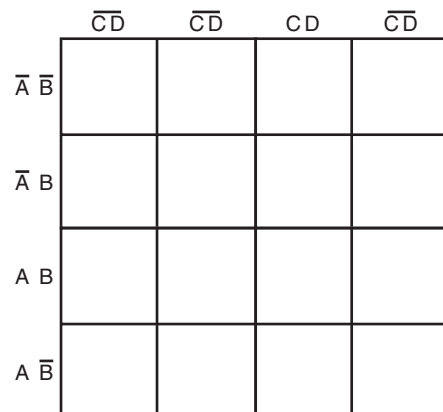
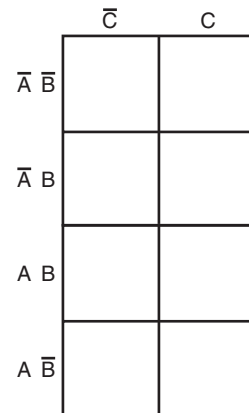
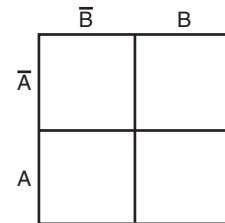
1. What is the function of a Veitch diagram?
2. How many variables can be represented on a Veitch diagram?
3. List the steps for using a Veitch diagram.
4. Simplify the following expressions using Veitch diagrams.
 - a. $\bar{A}\bar{B}\bar{C} + \bar{A}\bar{B}C + \bar{A}B\bar{C} + \bar{A}BC + A\bar{B}\bar{C} = Y$
 - b. $ABCD + \bar{A}\bar{B}\bar{C}\bar{D} + \bar{A}B\bar{C}\bar{D} + \bar{A}\bar{B}C\bar{D} + \bar{A}\bar{B}\bar{C}D + \bar{A}B\bar{C}D + \bar{A}B\bar{C}\bar{D} = Y$
 - c. $A\bar{B} + \bar{A}BD + \bar{B}CD + \bar{B}\bar{C} + \bar{A}BCD = Y$

34-2 KARNAUGH MAPS

Another technique for reducing complex Boolean expressions was developed by Maurice Karnaugh in 1953. His technique is similar to using Veitch diagrams. Figure 34-2 shows several Karnaugh

FIGURE 34-2

Two-, three-, and four-variable Karnaugh maps.



maps. It can be cumbersome to solve problems with five or six variables with either Veitch diagrams or Karnaugh maps. Those types of problems are best solved by other techniques or computer software designed specifically for them.

To use a Karnaugh map, follow these steps:

1. Draw the diagram based on the number of variables. As Figure 34–2 shows, a two-variable map requires $2^2 = 4$ squares, a three-variable map requires $2^3 = 8$ squares, and a four-variable map requires $2^4 = 16$ squares—the same requirements as a Veitch diagram.
2. Plot the logic functions by placing a “1” in each square representing a term.
3. Obtain the simplified logic function by looping adjacent groups of 1s in groups of eight, four, or two. Continue to loop until all 1’s are included.
4. “OR” the loops with one term per loop. (Each expression is pulled off the Karnaugh map and ORed using the “+” symbol (e.g., $ABC = BCD$).
5. Write the simplified expression.

EXAMPLE: Reduce $AB + \bar{A}B + A\bar{B} = Y$ to its simplest form.

Step 1. Draw the Karnaugh map. There are two variables, A and B, so use the two-variable map.

	\bar{B}	B
\bar{A}		
A		

Step 2. Plot the logic function by placing a “1” in each square representing a term

AB – first term

$\bar{A}B$ – second term

$A\bar{B}$ – third term

Plot 1st term AB

	\bar{B}	B
\bar{A}		
A		1

Plot 2nd term $\bar{A}B$

	\bar{B}	B
\bar{A}		1
A		1

Plot 3rd term $A\bar{B}$

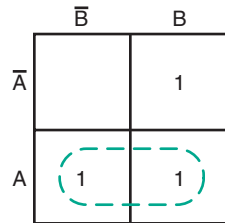
	\bar{B}	B
\bar{A}		1
A	1	1

Step 3. Loop adjacent groups of 1s in the largest group possible.

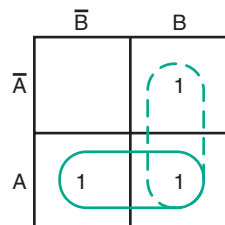
Start by analyzing the map for the largest groups possible. The largest group here is two.

	\bar{B}	B
\bar{A}		1
A	1	1

One possible group is the one indicated by the dotted line.



Another group is the one indicated by this dotted line.

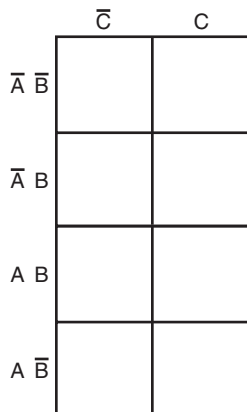


Step 4. "OR" the groups: either A or $B = A + B$.

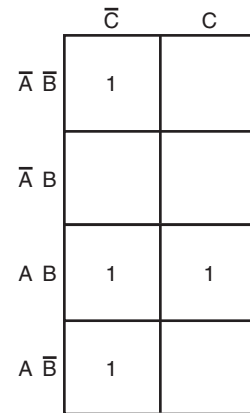
Step 5. The simplified expression for $AB + \bar{A}B + A\bar{B} = Y$ is $A + B = Y$ obtained from the Karnaugh map.

EXAMPLE: Find the simplified expression for $ABC + A\bar{B}C + AB\bar{C} + \bar{A}B\bar{C} = Y$

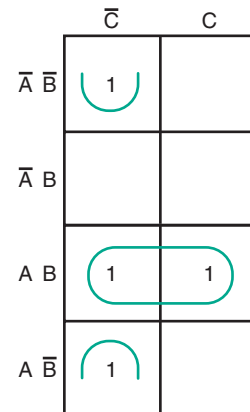
Step 1. Draw the Karnaugh map. There are three variables, A , B , and C , so use the three-variable map.



Step 2. Place a "1" in each square representing a term on the map.



Step 3. Loop adjacent groups of 1's in the largest group possible.



Step 4. Write the term for each loop, one term per expression:

$$AB, \bar{B}\bar{C}$$

Step 5. The simplified expression is $AB + \bar{B}\bar{C} = Y$

EXAMPLE: Find the simplified expression for $\bar{A}BCD + \bar{A}\bar{B}CD + \bar{A}B\bar{C}D + \bar{A}\bar{B}\bar{C}D + A\bar{B}CD + \bar{A}B\bar{C}D = Y$

Step 1. Draw the Karnaugh map. There are four variables, A , B , C , and D , so use the four-variable map.

	$\bar{C}\bar{D}$	$\bar{C}D$	CD	$C\bar{D}$
$\bar{A}\bar{B}$				
$\bar{A}B$				
AB				
$A\bar{B}$				

Step 2. Place a "1" in each square representing a term on the map.

	$\bar{C}\bar{D}$	$\bar{C}D$	CD	$C\bar{D}$
$\bar{A}\bar{B}$		1	1	
$\bar{A}B$		1	1	
AB				
$A\bar{B}$	1	1		

Step 3. Loop adjacent groups of 1's in the largest group possible.

	$\bar{C}\bar{D}$	$\bar{C}D$	CD	$C\bar{D}$
$\bar{A}\bar{B}$		1	1	
$\bar{A}B$		1	1	
AB				
$A\bar{B}$	1	1		

Step 4. Write the term for each loop, one term per expression:

$$\bar{A}D, A\bar{B}\bar{C}$$

Step 5. The simplified expression is $\bar{A}D + A\bar{B}\bar{C} = Y$

34-2 QUESTIONS

1. What is the function of a Karnaugh map?
2. What is the maximum number of variables that can be represented with a Karnaugh map?
3. Simplify the following expressions using Karnaugh maps:

a. $\bar{A}\bar{B}C + \bar{A}\bar{B}\bar{C} + A\bar{B}\bar{C} + \bar{A}\bar{B}\bar{C} + \bar{A}\bar{B}\bar{C} = Y$

b. $ABCD + \bar{A}\bar{B}\bar{C}D + \bar{A}B\bar{C}\bar{D} + \bar{A}\bar{B}\bar{C}D + \bar{A}\bar{B}\bar{C}\bar{D} + \bar{A}\bar{B}C\bar{D} + A\bar{B}\bar{C}\bar{D} = Y$

c. $\bar{A}\bar{B} + \bar{A}BD + \bar{B}\bar{C}D + \bar{B}\bar{C} + \bar{A}BCD = Y$

SUMMARY

- Veitch diagrams provide a fast and easy way to reduce complicated expressions to their simplest form.
- Veitch diagrams can be constructed from two, three, or four variables.
- The simplest logic expression is obtained from a Veitch diagram by looping groups of two, four, or eight X's and "OR"ing the looped terms.
- Like Veitch diagrams, Karnaugh maps provide a fast and easy method to reduce complex Boolean expressions to their simplest form.
- Karnaugh maps can be constructed for two, three, or four variables.
- The simplest logic expression is obtained from a Karnaugh map by looping groups of two, four, or eight 1's and "OR"ing the looped terms.

CHAPTER 34 SELF-TEST

1. Describe the procedure for using the Veitch diagram to simplify logic circuits.
2. Simplify the following Boolean expression by using a Veitch diagram:
$$\overline{A}BC\overline{D} + A\overline{B}C\overline{D} + \overline{A}C\overline{D} + A\overline{B}C + \overline{A}\overline{B} + A\overline{B}C\overline{D} = Y$$
3. Describe the procedure for using a Karnaugh map to simplify logic circuits.
4. Simplify the Boolean expression in question 2 using a Karnaugh map.

Sequential Logic Circuits

OBJECTIVES

After completing this chapter, the student should be able to:

- Describe the function of a flip-flop.
- Identify the basic types of flip-flops.
- Draw the symbols used to represent flip-flops.
- Describe how flip-flops are used in digital circuits.
- Describe how a counter and shift register operate.
- Identify the different types of counters and shift registers.
- Draw the symbols used to represent counters and shift registers.
- Identify applications of counters and shift registers.

Sequential logic circuits consist of circuits requiring timing and memory devices. The basic building block for sequential logic circuits is the flip-flop. Flip-flops can be wired together to form counters, shift registers, and memory devices.

The flip-flop belongs to a category of digital circuits called multivibrators. A multivibrator is a regenerative circuit with two active devices. It is designed so that one device conducts while the other device is cut off. Multivibrators can store binary numbers, count pulses, synchronize arithmetic operations, and perform other essential functions in digital systems.

There are three types of multivibrators: bistable, monostable, and astable. The bistable multivibrator is called a flip-flop.



See accompanying CD for interactive presentations, tutorials, and DC Circuit examples in MultiSim, Chapter 35.

35-1 FLIP-FLOPS

A **flip-flop** is a bistable multivibrator whose output is either a high or low voltage, a 1 or a 0. The output stays high or low until an input called a trigger is applied.

The basic flip-flop is the *RS flip-flop*. It is formed by two cross-coupled NOR or NAND gates (Figure 35-1). The **RS flip-flop** has two outputs, Q and \bar{Q} , and two controlling inputs, R (Reset) and S (Set). The outputs are always opposite or complementary: If $Q = 1$, then $\bar{Q} = 0$, and vice-versa.

To understand the operation of the circuit, assume that the Q output, R input, and S input are all low. The low on the Q output is connected to one of the inputs of gate 2. The S input is low. The output of gate 2 is high. This high is coupled to the input of gate 1, holding its output to a low. When the Q output is low, the flip-flop is said to be in the RESET state. It remains in this state indefinitely, until a high is applied to the S input of gate 2. When a high is applied to the S input of gate 2, the output of gate 2 becomes a low and is coupled to the input of gate 1. Because the R input of gate 1 is a low, the output changes to a high. The high is

coupled back to the input of gate 2, ensuring that the Q output remains a low. When the Q output is high, the flip-flop is said to be in the SET state. It remains in the SET state until a high is applied to the R input, causing the flip-flop to RESET.

An “illegal” or “unallowed” condition occurs when a high is applied to both the R and S inputs simultaneously. In this case, the Q and \bar{Q} outputs both try to go low, but Q and \bar{Q} cannot be in the same state at the same time without violating the definition of flip-flop operation. When the highs on the R and S inputs are removed simultaneously, both of the outputs attempt to go high. Because there is always some difference in the gates, one gate dominates and becomes high. This forces the other gate to remain low. An unpredictable mode of operation exists and therefore the output state of the flip-flop cannot be determined.

Figure 35-2 shows the truth table for operation of an RS flip-flop. Figure 35-3 is a simplified symbol used to represent an RS flip-flop.

Another type of flip-flop is called a **clocked flip-flop**. It is different from the RS flip-flop in that an additional input is required for operation. The third input is called the clock or trigger. Figure 35-4 shows a logic diagram for a clocked flip-flop. A high at either input of the flip-flop portion activates the flip-flop, causing it to change states. The

FIGURE 35-1
Basic flip-flop circuit.

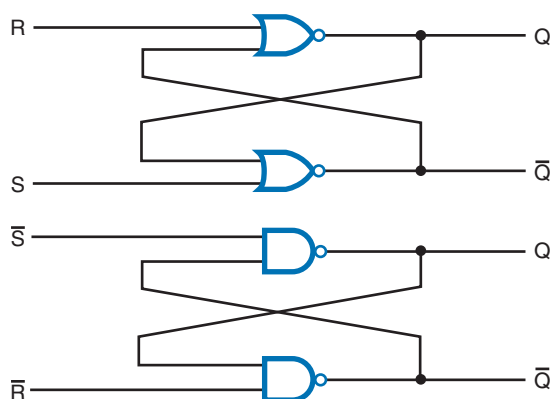


FIGURE 35-2
Truth table for an RS flip-flop.

INPUTS		OUTPUTS	
S	R	Q	\bar{Q}
0	0	NC	NC
0	1	0	1
1	0	1	0
1	1	0	0

NC = No Change

FIGURE 35-3

Logic symbol for an RS flip-flop.

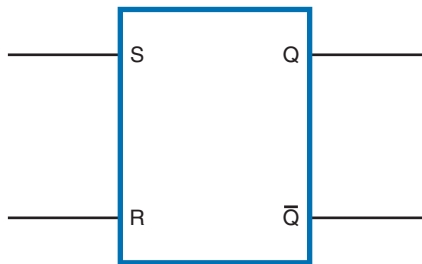


FIGURE 35-5

Logic symbol for a positive-edge-triggered RS flip-flop.

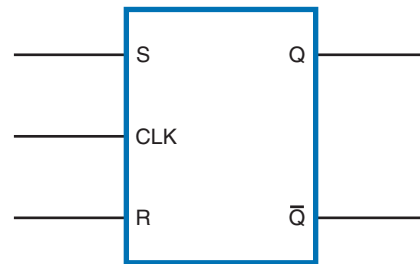
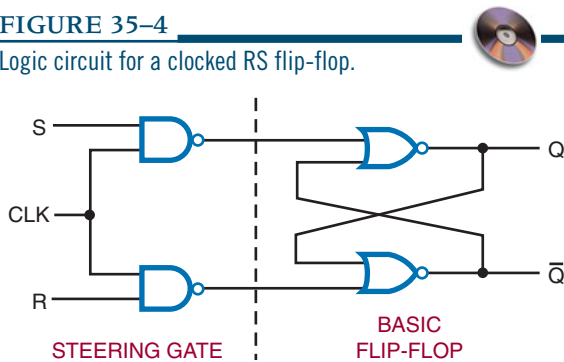


FIGURE 35-4

Logic circuit for a clocked RS flip-flop.



portion labeled “steering gate” steers or directs the clock pulses to either input gate.

The clocked flip-flop is controlled by the logic state of the S and R inputs when a clock pulse is present. A change in the state of the flip-flop occurs only when the leading edge of the clock pulse is applied. The leading edge of the

clock pulse is a positive-going transition (low to high). This means that the pulse goes from a zero voltage level to a positive voltage level. This is referred to as positive edge-triggered (the edge of the pulse is what triggers the circuit).

As long as the clock input is low, the S and R inputs can be changed without affecting the state of the flip-flop. The only time that the effects of the S and R inputs are felt is when a clock pulse occurs. This is referred to as synchronous operation. The flip-flop operates in step with the clock. Synchronous operation is important in computers and calculators when each step must be performed in an exact order. Figure 35-5 shows the logic symbol used to represent a positive-edge-triggered RS flip-flop.

A **D flip-flop** is useful where only one data bit (1 or 0) is to be stored. Figure 35-6 shows the logic diagram for a D flip-flop. It has a single data input and a clock input. The D flip-flop is also re-

FIGURE 35-6

Logic circuit and symbol for the D flip-flop.

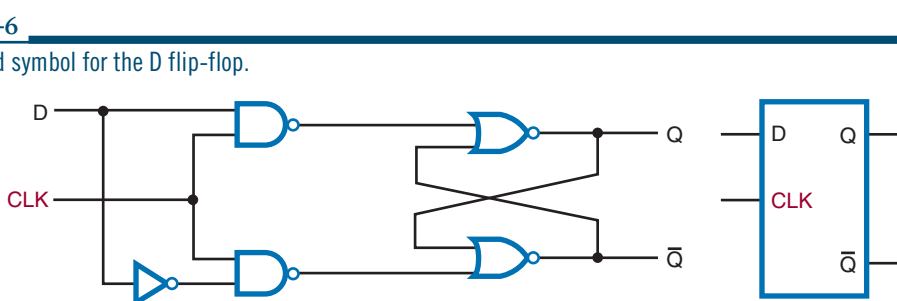
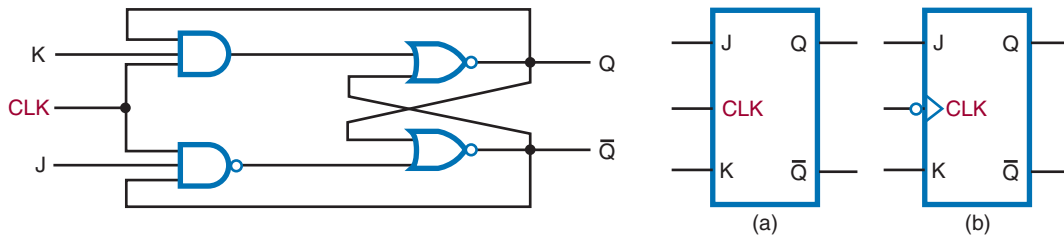


FIGURE 35-7

Logic circuit and symbol for the JK flip-flop.



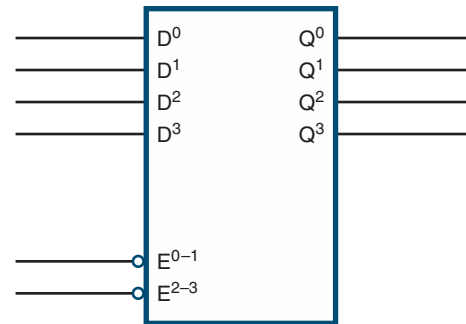
ferred to as a *delay flip-flop*. The D input is delayed one clock pulse from getting to the output (Q). Sometimes the D flip-flop has a PS (preset) input and CLR (clear) input. The preset input sets output Q to a 1 when a low or 0 is applied to it. The clear input clears the Q output to a 0 when it is enabled by a low or 0. D flip-flops are wired together to form shift registers and storage registers. These registers are widely used in digital systems.

The **JK flip-flop** is the most widely used flip-flop. It has all the features of the other types of flip-flops. It is also edge triggered, accepting data only at the J and K inputs that are present at the active clock edge (high to low or low to high). This allows the accepting of input data on J and K at a precise instant. The logic diagram and symbol for the JK flip-flop is shown in Figure 35-7. J and K are the inputs. The significant feature of the JK flip-flop is that when both the J and K inputs are high, repeated clock pulses cause the output to toggle or change state. The two asynchronous inputs, PS (preset) and CLR (clear), override the synchronous inputs, the J and K data inputs, and the clock input. JK flip-flops are widely used in many digital circuits, especially counter circuits. Counters are found in almost every digital system.

A **latch** is a device that serves as a temporary buffer memory. It is used to hold data after the input signal is removed. The D flip-flop is a good example of a latch device. Other types of flip-flops can also be used.

FIGURE 35-8

Four-bit latch.



A latch is used when inputting to a seven-segment display. Without a latch, the information being displayed is removed when the input signal is removed. With the latch, the information is displayed until it is updated.

Figure 35-8 shows a 4-bit latch. The unit has four D flip-flops enclosed in a single IC package. The E (enable) inputs are similar to the clock input of the D flip-flop. The data are latched when the enable line drops to a low, or 0. When the enable is high, or 1, the output follows the input. This means that the output will change to whatever state the input is in; for example, if the input is high, the output will become high; if the input is low, the output will become low. This condition is referred to as a *transparent latch*.

35-1 QUESTIONS

1. What is a flip-flop?
2. What are the different types of flip-flops?
3. What is meant by a clocked flip-flop?
4. What is the difference between an asynchronous input and a synchronous input?
5. What is a latch?

35-2 COUNTERS

A **counter** is a logic circuit that can count a sequence of numbers or states when activated by a clock input. The output of a counter indicates the binary number stored in the counter at any given time. The number of counts or states through which a counter progresses before returning to its original state (recycling) is called the **modulus** of the counter.

A flip-flop can act as a simple counter when connected as shown in Figure 35-9. Assuming that initially the flip-flop is reset, the first clock pulse causes it to set ($Q = 1$). The second clock pulse causes it to reset ($Q = 0$). Because the flip-flop has set and reset, two clock pulses have occurred.

FIGURE 35-9
JK flip-flop set up for counting.

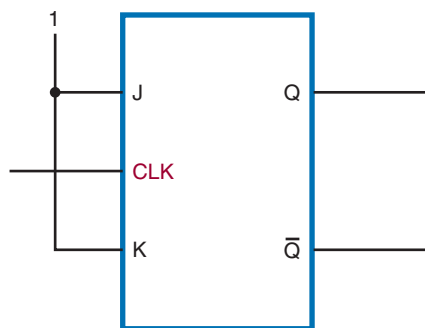


FIGURE 35-10

Input and output waveforms of JK flip-flop set up as a counter.

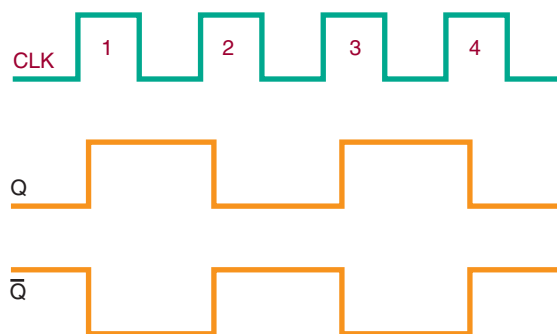


Figure 35-10 shows the output waveform of the flip-flop. Notice that the Q output is high (1) after every odd clock pulse and low (0) after every even clock pulse. Therefore, when the output is high, an odd number of clock pulses has occurred. When the output is low, either no clock pulses or an even number of clock pulses has occurred. In this case, it is not known which has occurred.

A single flip-flop produces a limited counting sequence, 0 or 1. To increase the counting capacity, additional flip-flops are needed. The maximum number of binary states in which a counter can exist depends on the number of flip-flops in the counter. This can be expressed as:

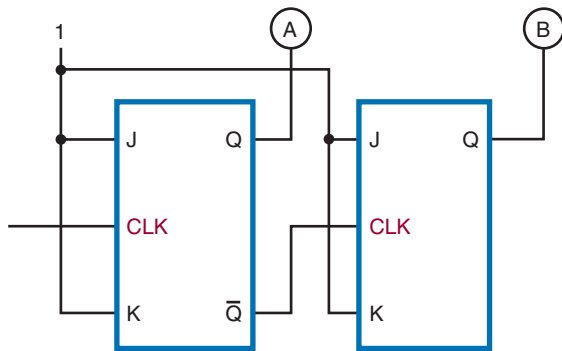
$$N = 2^n$$

where: N = maximum number of counter states
 n = number of flip-flops in counter

Binary counters fall into two categories based on how the clock pulses are used to sequence the counter. The two categories are asynchronous and synchronous.

Asynchronous means not occurring at the same time. With respect to counter operations, asynchronous means that the flip-flops do not change states at the same time. This is because the clock pulse is not connected to the clock input of each stage. Figure 35-11 shows a two-stage counter connected for asynchronous operation. Each flip-flop in a counter is referred to as a *stage*.

FIGURE 35–11
Two-stage counter.



Notice that the \bar{Q} output of the first stage is coupled to the clock input of the second stage. The second stage only changes state when triggered by the transition of the output of the first stage. Because of the delay through the flip-flop, the second flip-flop does not change state at the same time the clock pulse is applied. Therefore, the two flip-flops are never simultaneously triggered, which results in asynchronous operation.

Asynchronous counters are commonly referred to as *ripple counters*. The input clock pulse is first felt by the first flip-flop. The effect is not felt by the second flip-flop immediately because of the delay through the first flip-flop. In a multiple-stage counter, the delay is felt through each flip-flop, so that the effect of the input clock pulse “ripples” through the counter. Figure 35–12 shows a three-stage binary counter and timing chart for each of the stages. A truth table is also shown to show the counting sequence.

Synchronous means occurring at the same time. A *synchronous counter* is a counter in which each stage is clocked at the same time. This is accomplished by connecting the clock input to each stage of the counter (Figure 35–13). A synchronous counter is also called a *parallel counter* because the clock input is connected in parallel to each flip-flop.

A synchronous counter operates as follows. Initially the counter is reset with both flip-flops in the 0 state. When the first clock pulse is applied, the first flip-flop toggles and the output goes high. The second flip-flop does not toggle because of the delay from the input to the actual changing of the output state. Therefore, there is no change in the second flip-flop output state. When the second clock pulse is applied, the first flip-flop toggles and the output goes low. Because there is a high from the output of the first stage, the second stage toggles and its output goes high. After four clock pulses, the counter recycles to its original state. Figure 35–14 shows a timing chart for this sequence of events with a two-stage synchronous counter.

Figure 35–15 shows a three-stage binary counter and timing chart. Figure 35–16 shows a four-stage synchronous counter and logic symbol.

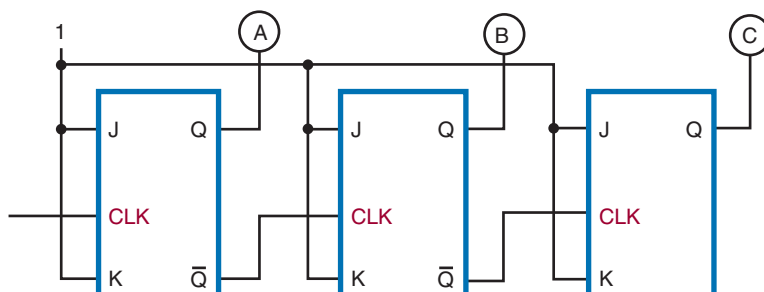
One application of a counter is frequency division. A single flip-flop produces an output pulse for every two input pulses. Therefore, it is essentially a divide-by-two device with an output one-half the frequency of the input. A two-stage binary counter is a divide-by-four device with an output equal to one-fourth the input clock frequency. A four-stage binary counter is a divide-by-sixteen device with the output equal to one-sixteenth the input clock frequency (Figure 35–17).

A binary counter with n stages divides the clock frequency by a factor of 2^n . A three-stage counter divides the frequency by eight (2^3), a four-stage counter by sixteen (2^4), a five-stage counter by thirty-two (2^5), and so on. Notice that the modulus of the counter is the same as the division factor.

Decade counters have a modulus of ten, or ten states in their counting sequence. A common decade counter is the BCD (8421) counter, which produces a binary-coded-decimal sequence (Figure 35–18). The AND and OR gates detect the occurrence of the ninth state and cause the counter to recycle on the next clock pulse. The symbol for a decade counter is shown in Figure 35–19.

FIGURE 35-12

Three-stage binary counter.



NUMBER OF CLOCK PULSES	BINARY COUNT SEQUENCE			DECIMAL COUNT
	C	B	A	
0	0	0	0	0
1	0	0	1	1
2	0	1	0	2
3	0	1	1	3
4	1	0	0	4
5	1	0	1	5
6	1	1	0	6
7	1	1	1	7
8	0	0	0	0

COUNT SEQUENCE

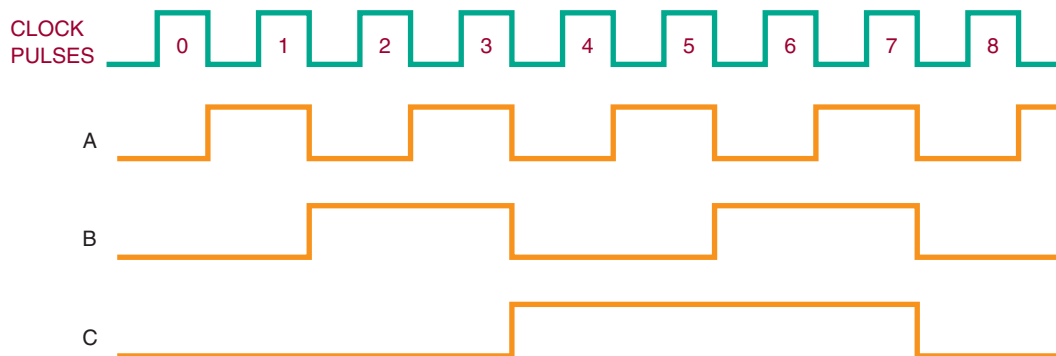


FIGURE 35-13
Two-stage synchronous counter.

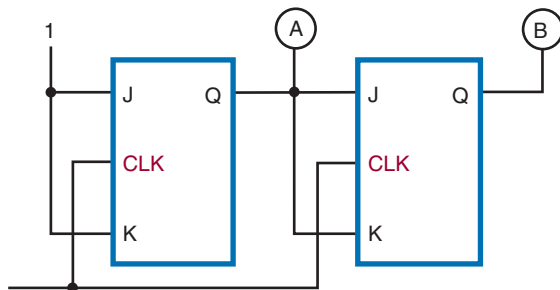
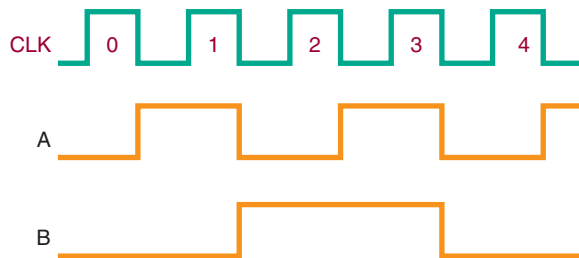


FIGURE 35-14
Input and output waveforms for the two-stage synchronous counter.



An **up-down counter** can count in either direction through a certain sequence. It is also referred to as a bidirectional counter. The counter can be reversed at any point in the counting sequence. Its symbol is shown in Figure 35-20. An up-down counter can consist of any number of stages. Figure 35-21 shows the logic diagram for a BCD up-down counter. The inputs to the JK flip-flops are enabled by the up-down input qualifying the up or down set of the AND gates.

Counters can be stopped after any sequence of counting by using a logic gate or combination of logic gates. The output of the gate is fed back to the input of the first flip-flop in a ripple counter.

If a 0 is fed back to the JK input of the first flip-flop (Figure 35-22) it prevents the first flip-flop from toggling, thereby stopping the count.

35-2 QUESTIONS

1. What function does a counter serve?
2. How many counting sequences are available with an eight-stage counter?
3. How does an asynchronous counter operate?
4. How does a synchronous counter differ from an asynchronous counter?
5. How can a counter be made to stop at any count desired?

35-3 SHIFT REGISTERS

A **shift register** is a sequential logic circuit widely used to store data temporarily. Data can be loaded into and removed from a shift register in either a parallel or serial format. Figure 35-23 shows the four different methods of loading and reading data in a shift register. Because of its ability to move data one bit at a time from one storage medium to another, the shift register is valuable in performing a variety of logic operations.

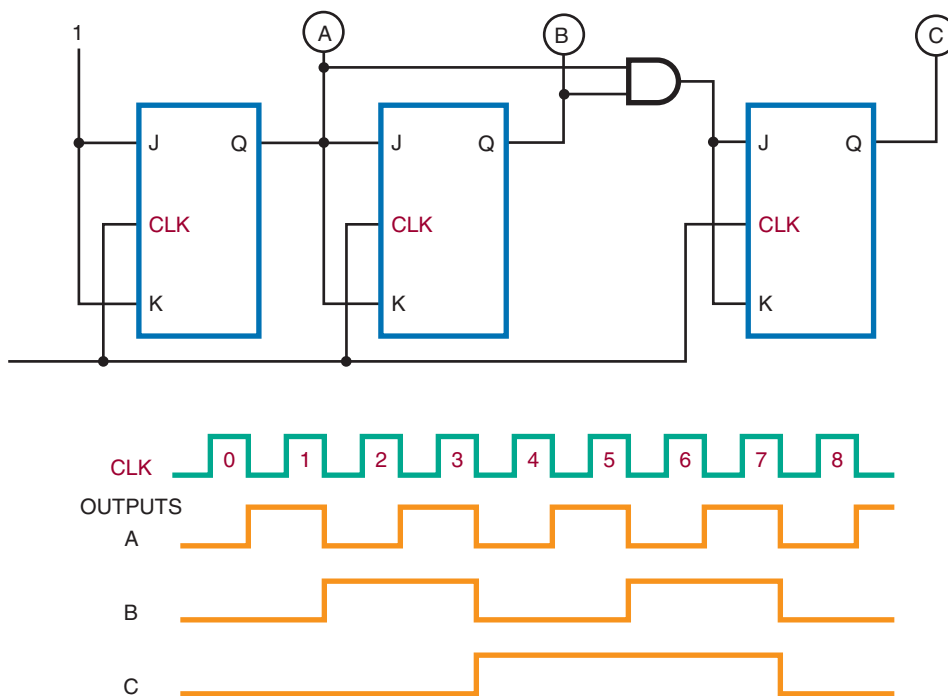
Shift registers are constructed of flip-flops wired together. Flip-flops have all the functions necessary for a register: They can be reset, preset, toggled, or steered to a 1 or 0 level. Figure 35-24 shows a basic shift register constructed from four flip-flops. It is called a 4-bit shift register because it consists of four binary storage elements.

A significant feature of the shift register is that it can move data to the right or left a number of bit positions. This is equivalent to multiplying or dividing a number by a specific factor. The data are shifted one bit position at a time for each input clock pulse. The clock pulses have full control over the shift register operations.

Figure 35-25 shows a typical 4-bit shift register constructed of JK flip-flops. The serial data and their complements are applied to the JK inputs of

FIGURE 35-15

Three-stage binary counter and timing chart.



NUMBER OF CLOCK PULSES	BINARY COUNT SEQUENCE			DECIMAL COUNT
	C	B	A	
0	0	0	0	0
1	0	0	1	1
2	0	1	0	2
3	0	1	1	3
4	1	0	0	4
5	1	0	1	5
6	1	1	0	6
7	1	1	1	7
8	0	0	0	0

FIGURE 35-16

Logic symbol for a four-stage synchronous counter.

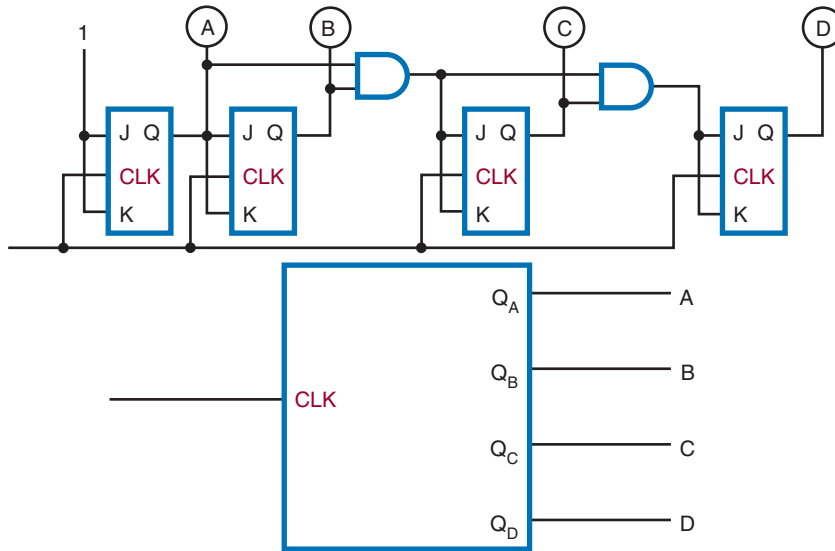


FIGURE 35-17

A counter as a frequency divider.

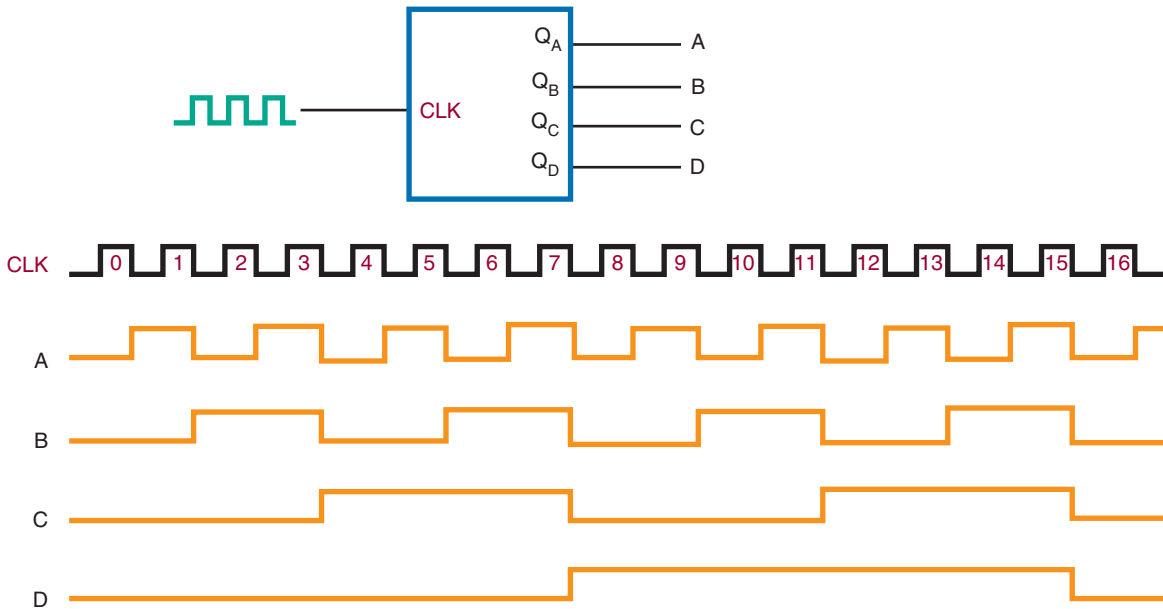


FIGURE 35-18

Synchronous BCD decade counter.

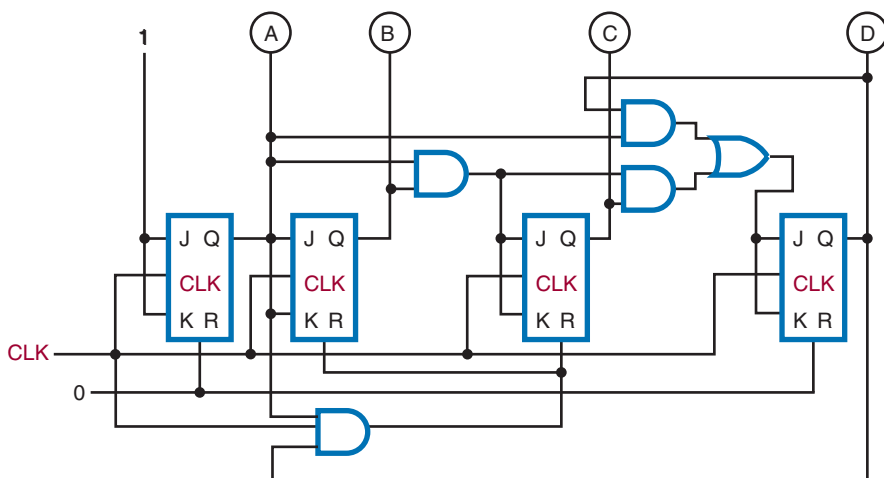


FIGURE 35-19

Logic symbol for a decade counter.

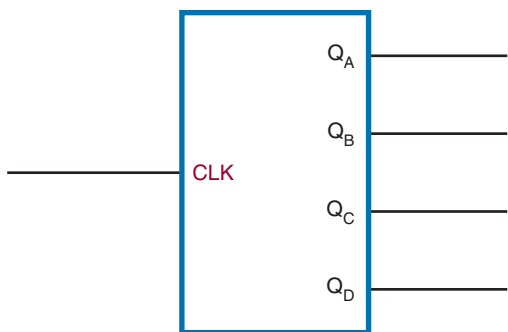


FIGURE 35-20

Logic symbol for an up-down counter.

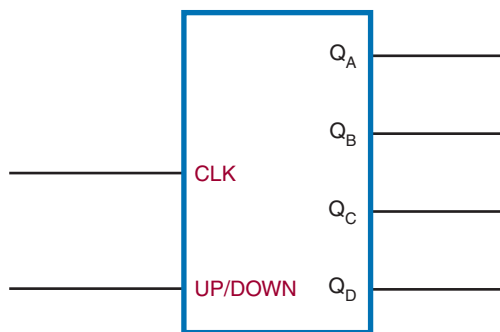


FIGURE 35-21

Logic diagram for a BCD up-down counter.

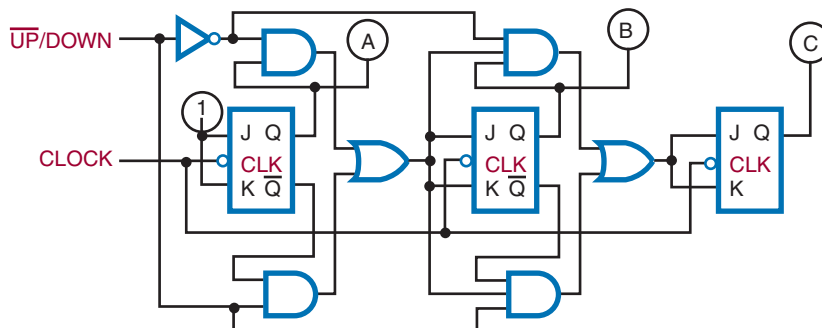


FIGURE 35-22

A low applied to the JK input of the first flip-flop prevents it from toggling, stopping the count.

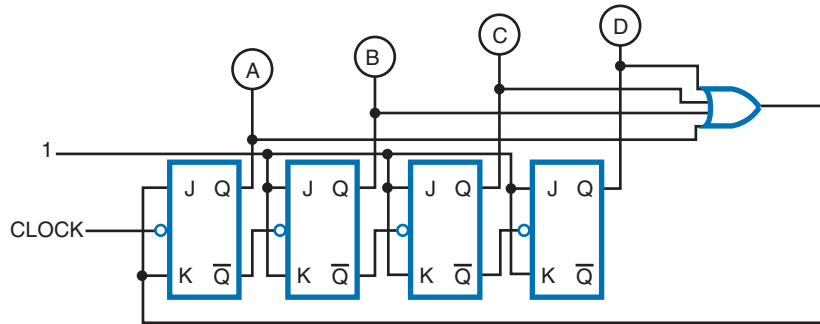


FIGURE 35-23

Methods of loading and reading data in a shift register.

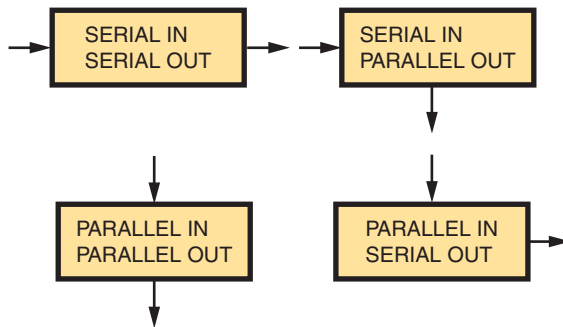


FIGURE 35-24

Shift register constructed from four flip-flops.

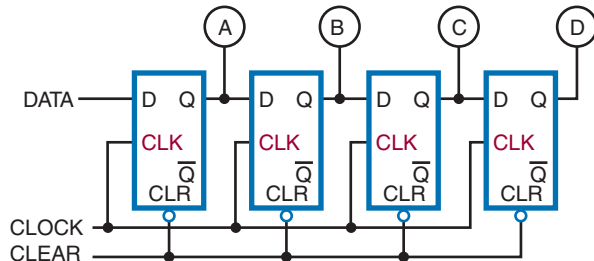
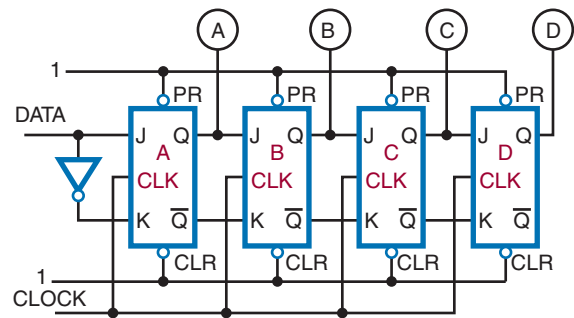


FIGURE 35-25

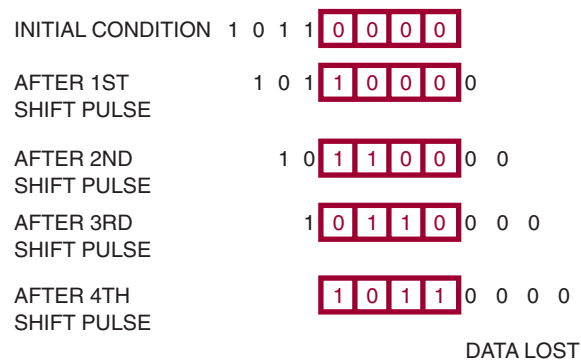
A typical shift register constructed of JK flip-flops.



the A flip-flop. The other flip-flops are cascaded, with the outputs of one connected to the inputs of the next. The toggles of all the flip-flops are connected together, and the clock pulse is applied to this line. Because all the flip-flops are toggled together, this is a synchronous circuit. Also, the clear inputs of each flip-flop are tied together to form a reset line. Data applied to the input are shifted through the flip-flops one bit position for each clock pulse. For example, if the binary number 1011 is applied to the input of the shift register and a shift pulse is applied, the number stored in the shift register is shifted out and lost while the external number is shifted in. Figure 35-26 shows

FIGURE 35–26

Storing a number in a shift register.



the sequence of events for storing a number in the shift register.

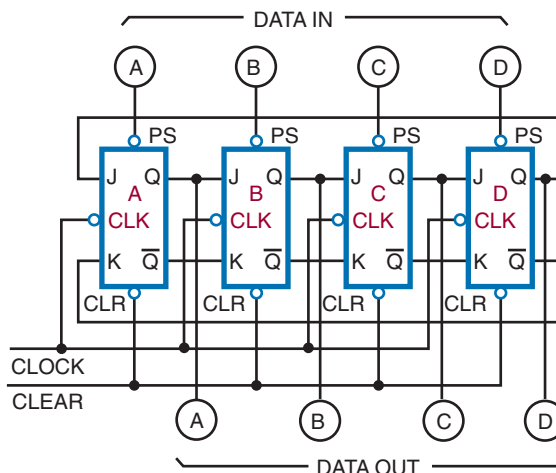
One of the most common applications of a shift register is serial-to-parallel or parallel-to-serial data conversion. Figure 35–27 shows how a shift register can be loaded by a parallel input. For parallel operations, the input data are preset into the shift register. Once the data are in the shift register, they can be shifted out serially, as discussed earlier.

For serial-to-parallel data conversion, the data are initially shifted into the shift register with clock pulses. Once the data are in the shift register, the outputs of the individual flip-flops are monitored simultaneously, and the data are routed to their destination.

Shift registers can perform arithmetic operations such as multiplication or division. Shifting a

FIGURE 35–27

Loading a shift register using parallel input.

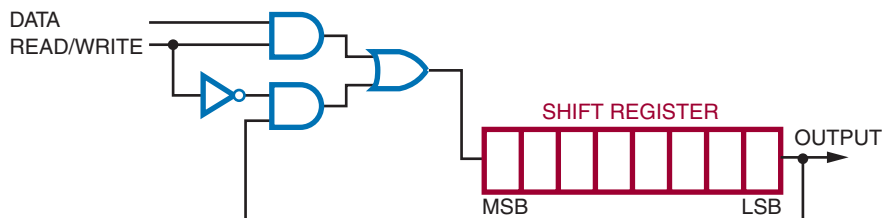


binary number stored in the shift register to the right has the same effect as dividing the number by some power of 2. Shifting the binary number stored in the shift register to the left has the same effect as multiplying the number by some power of 2. Shift registers are a simple and inexpensive means of performing multiplication and division of numbers.

Shift registers are often used for temporary storage. They are capable of storing one or more binary words. There are three requirements for this application of a shift register: First, it must be able to accept and store data. Second, it must be able to retrieve or read out the data on command. Third, when the data are read, they must not be lost. Figure 35–28 shows the external circuitry re-

FIGURE 35–28

Shift register circuitry for maintaining and reading data.



quired to enable a shift register to read and maintain the data stored in it. The read/write line, when high, allows new data to be stored in the shift register. Once the data is stored, the read/write line goes low, enabling gate 2, which allows the data to recirculate while reading out the data.

35-3 QUESTIONS

1. What is the function of a shift register?
2. What is a significant feature of a shift register?
3. From what are shift registers constructed?
4. What is a common application of a shift register?
5. What arithmetic operations can a shift register perform, and how does it perform them?

35-4 MEMORY

Memory serves to store digital data on a temporary or permanent basis. Because of the different ways that the stored data are used in digital systems, many different types of memories have evolved, each designed for a particular application.

Memory is built from storage registers. Storage registers store the digital data, such as programs or data, on a short term in digital systems. The flip-flop is the basic building block for storage registers.

A four-bit register stores four bits, referred to as a *nibble*; and eight-bit register stores eight bits called a *byte*; and a larger register stores a *word*. Typical word sizes are 16, 32, 64, and 128 bits. Four-, eight-, and sixteen-bit registers are shown in Figure 35-29. By looking at the Q output, the status of the data stored can be checked in any of these registers. The complementary data are also available by looking at the \bar{Q} output.

FIGURE 35-29

Four-, eight-, and sixteen-bit registers.

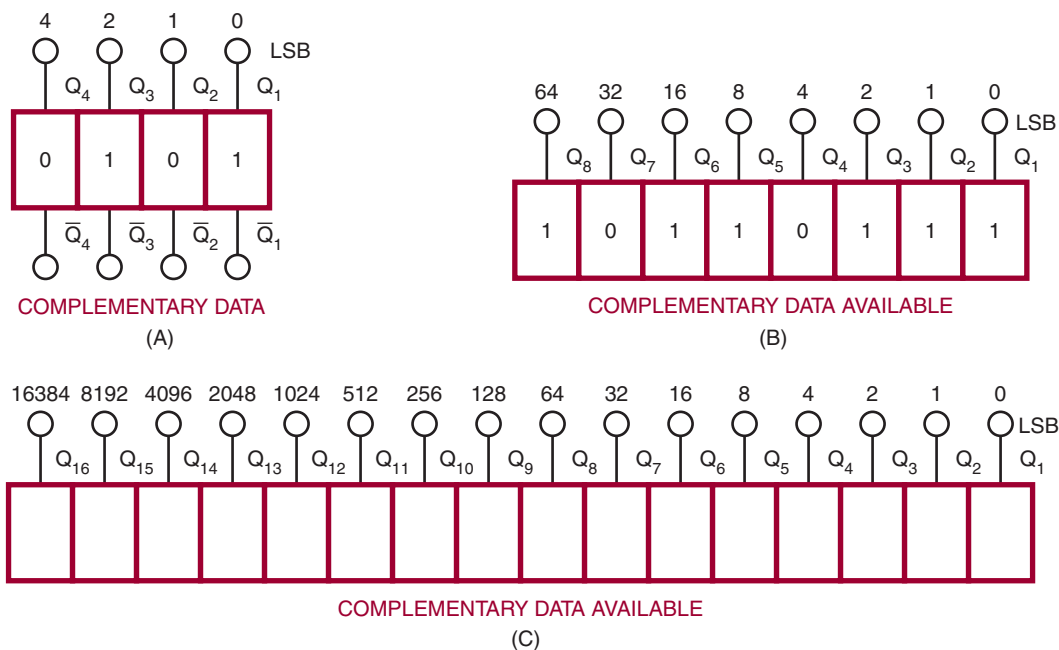


FIGURE 35–30

Large memory array (eight bit).

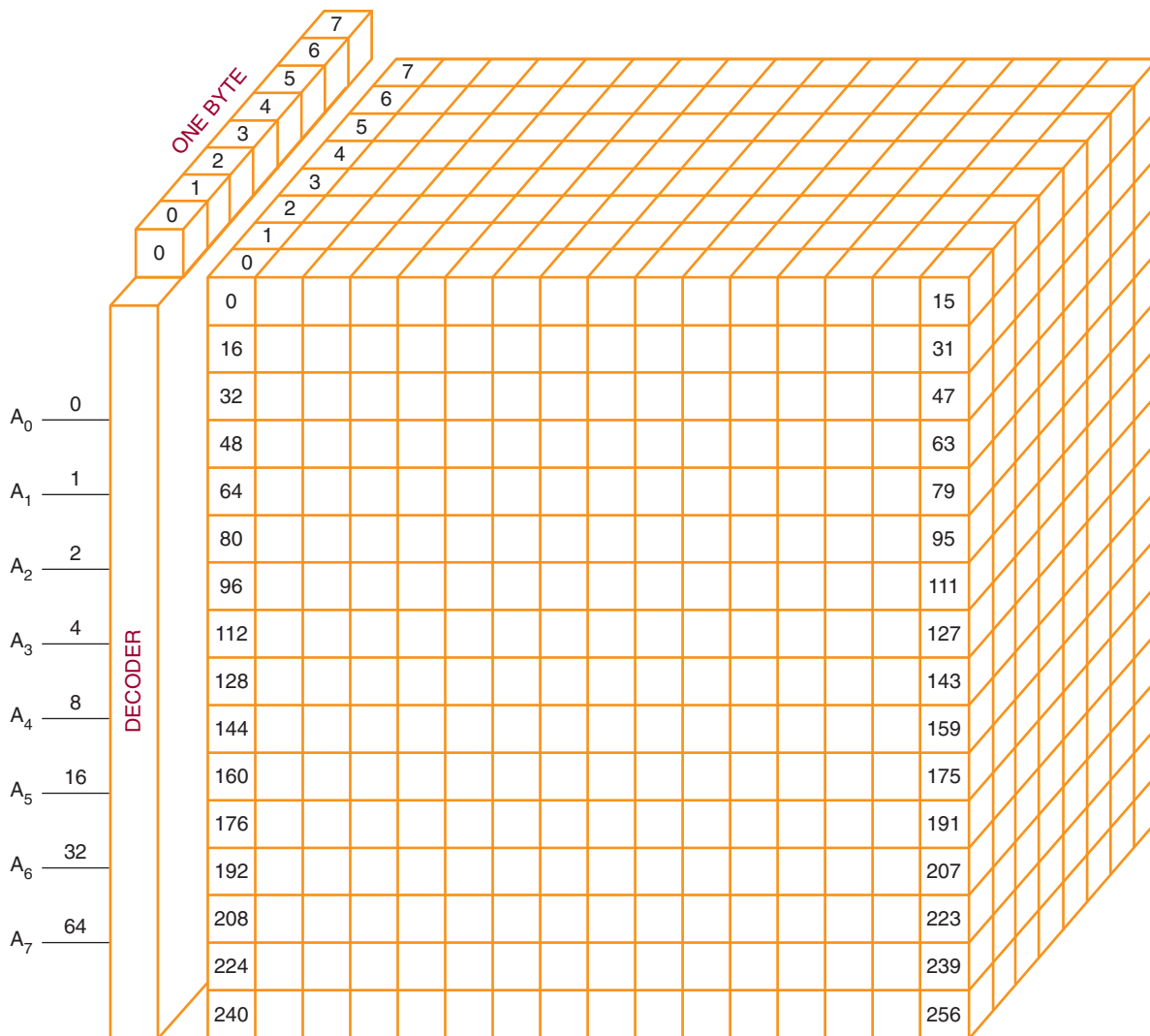
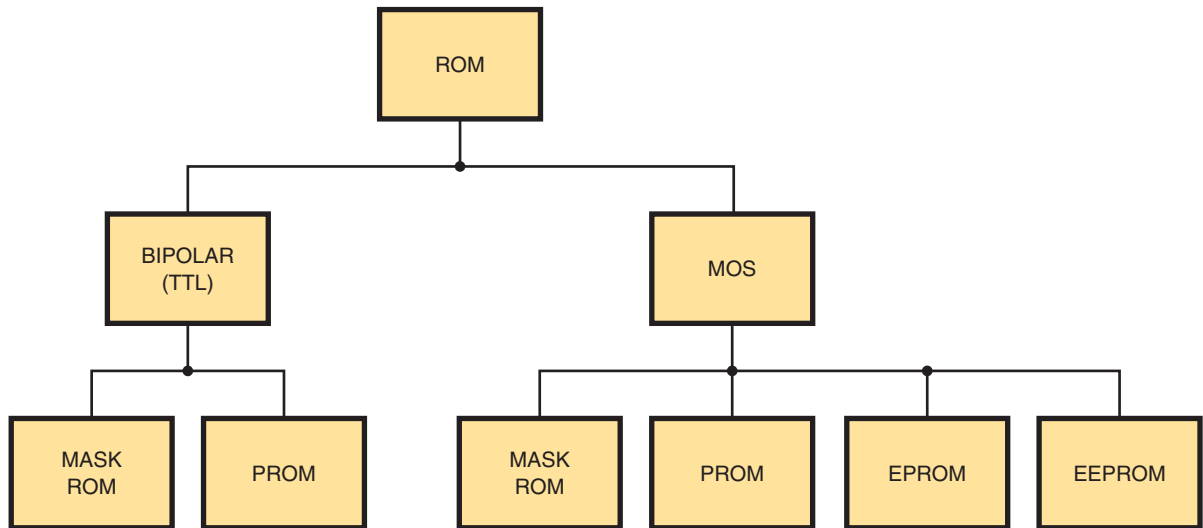


Figure 35–30 shows how data are stored in a larger memory configuration. A matrix of storage elements capable of storing a 1 or a 0 is organized into words that a decoder can locate by a specific address.

The technology used in making the memory integrated circuits (chips) is based on either bipolar

(also referred to as transistor-to-transistor logic [TTL]) or MOS transistors. Bipolar memory is faster than MOS memory, but MOS memory can be packed with a higher density, providing more memory locations in the same amount of area required by bipolar memory.

FIGURE 35–31
ROM family chart.



Data are stored digitally in two types of memory: random-access memory and read-only memory. Random-access memory (RAM) is used for the temporary storage of programs, data, control information, and so on. It provides random access to the stored data with all storage locations being reached in the same amount of time. RAM has the capability to both read and write data. It is also volatile. This means that the stored data will be lost if the power is shut off.

Two types of RAM are available: static and dynamic. Static RAM (SRAM) uses a bistable circuit as the storage element. It loses data when the power is removed. Dynamic RAM (DRAM) is different because it uses capacitors to store the data. The drawback is that the capacitors will discharge over time and must be recharged or refreshed periodically to maintain the stored data. Even with the additional support circuit requirement, SRAMs are still cheaper and have a higher density, reducing the circuit board area required.

Read-only memory (ROM) allows data to be permanently stored and allows the data to be read from memory at any time with no provision for data to be written to it. ROMs are considered as nonvolatile memory. ROMs use the same decoder circuitry as RAM. The stored data are retained even when the power is removed. ROMs may be programmed during manufacture to be either permanent or replaceable by the user, but they are not easily altered and require the use of a special device called a *burner*.

Figure 35–31 shows the ROM family chart. The mask-programming process takes place during the manufacturing process. The transistor-emitter connection is either made or not made through a mask during manufacture. The mask does the programming.

Programmable read-only memory (PROM) can be programmed after manufacture. The program is entered into the PROM by blowing a fusible link. Initially all emitter links are connected as 1's in all storage locations. The emitter

links where 0's occur are blown open with a high-current surge. PROMs cannot be reprogrammed.

Electrically erasable PROMs can be programmed and erased by using an electrical charge. By applying a high voltage (around 21 volts), a single byte or the entire chip can be erased in about 10 milliseconds. Erasing can be done with the chip in the circuit. EEPROMs are used where data need to be maintained for later use, such as the custom guide in a television satellite system.

35-4 QUESTIONS

1. What is memory?
2. What are the two types of technology used to make memory chips?
3. What are the two types of memory devices?
4. What is meant by the term *volatile*?
5. Describe a situation in which it would be advantageous to convert from EPROM memory design to the mask-ROM.

SUMMARY

- A flip-flop is a bistable multivibrator whose output is either a high or a low.
- Types of flip-flops include:
 - a. RS
 - b. Clocked RS
 - c. D
 - d. JK
- Flip-flops are used in digital circuits such as counters.
- A latch is a temporary buffer memory.
- A counter is a logic circuit that can count a sequence of numbers or states.
- A single flip-flop produces a count sequence of 0 or 1.
- The maximum number of binary states a counter can have depends on the number of flip-flops contained in the counter.
- Counters can be either asynchronous or synchronous.
- Asynchronous counters are called ripple counters.
- Synchronous counters clock each stage at the same time.
- Shift registers are used to store data temporarily.
- Shift registers are constructed of flip-flops wired together.
- Shift registers can move data to the left or right.
- Shift registers are used for serial-to-parallel and parallel-to-serial data conversions.
- Shift registers can perform multiplication and division.
- Memory stores data temporarily or permanently.
- Memory is built from shift registers.
- A four-bit register stores a nibble.
- An eight-bit register stores a byte.
- A sixteen-bit register stores a word.
- Bipolar memory is faster than MOS memory.
- MOS memory can pack a higher density, providing more memory location in the same area for bipolar memory.
- Data is stored into two types of memory: random-access memory (RAM) or read-only memory (ROM).
- Two types of RAM are available: static RAM (SRAM) or dynamic RAM (DRAM).
- Programmable read-only memory (PROM) can be programmed after manufacture.
- Electrically erasable PROMs (EEPROMs) can be programmed and erased using an electrical charge.

CHAPTER 35 SELF-TEST

1. Describe how an RS flip-flop changes states from a high on the Q output to a high on the \overline{Q} output.
2. What is the major difference between the D flip-flop and the clocked RS flip-flop?
3. What components make up a counter, and how is it constructed?
4. Draw a schematic for a counter that will count to 10 and then repeat.
5. How does a shift register differ from a counter?
6. For what functions/applications can the shift register be used?

Combinational Logic Circuits

OBJECTIVES

After completing this chapter, the student will be able to:

- Describe the functions of encoders, decoders, multiplexers, adders, subtractors, and comparators.
- Identify the schematic symbols for encoders, decoders, multiplexers, adders, subtractors, and comparators.
- Identify applications for combinational logic circuits.
- Develop truth tables for the different combinational logic circuits.

Combinational logic circuits are circuits that combine the basic components of AND gates, OR gates, and inverters to produce more sophisticated circuits. The output of a combinational logic circuit is a function of the states of the inputs, the types of gates used, and the interconnection of the gates. The most common of the combinational circuits are decoders, encoders, multiplexers, and arithmetic circuits.



See accompanying CD for interactive presentations, tutorials, and DC Circuit examples in MultiSim, Chapter 36.

36-1 ENCODERS

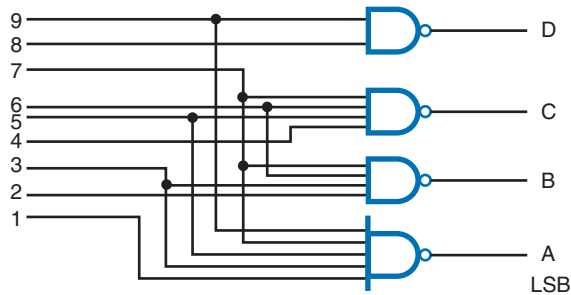
An **encoder** is a combinational logic circuit that accepts one or more inputs and generates a multibit binary output. *Encoding* is the process of converting any keyboard character or number as input to a coded output such as a binary or BCD form.

Figure 36-1 shows a **decimal-to-binary encoder**. Its function is to take a single digit (0 to 9) as input and to output a 4-bit code representation of the digit. This is referred to as a 10-line-to-4-line

encoder. That is, if the digit 4 on the keyboard is typed in, this produces low or a 0 on line 4, which produces the 4-bit code 0100 as an output.

Figure 36-2 shows a **decimal-to-binary priority encoder**. The priority function means that if two keys are pressed simultaneously the encoder produces a BCD output corresponding to the highest-order decimal digit appearing on the input. For example, if both a 5 and a 2 are applied to the encoder, the BCD output is 1010, or the invert of decimal 5. This type of encoder is built into a

FIGURE 36-1
Decimal-to-binary encoder.



single integrated circuit and consists of approximately thirty logic gates. Figure 36-3 shows the symbol for a priority encoder.

This type of encoder is used to translate the decimal input from a keyboard to an 8421 BCD code. The decimal-to-binary encoder and the decimal-to-binary priority encoder are found wherever there is keyboard input. This includes: calculators, computer keyboard inputs, electronic typewriters, and teletypewriters (TTY).

FIGURE 36-2
Decimal-to-binary priority encoder.

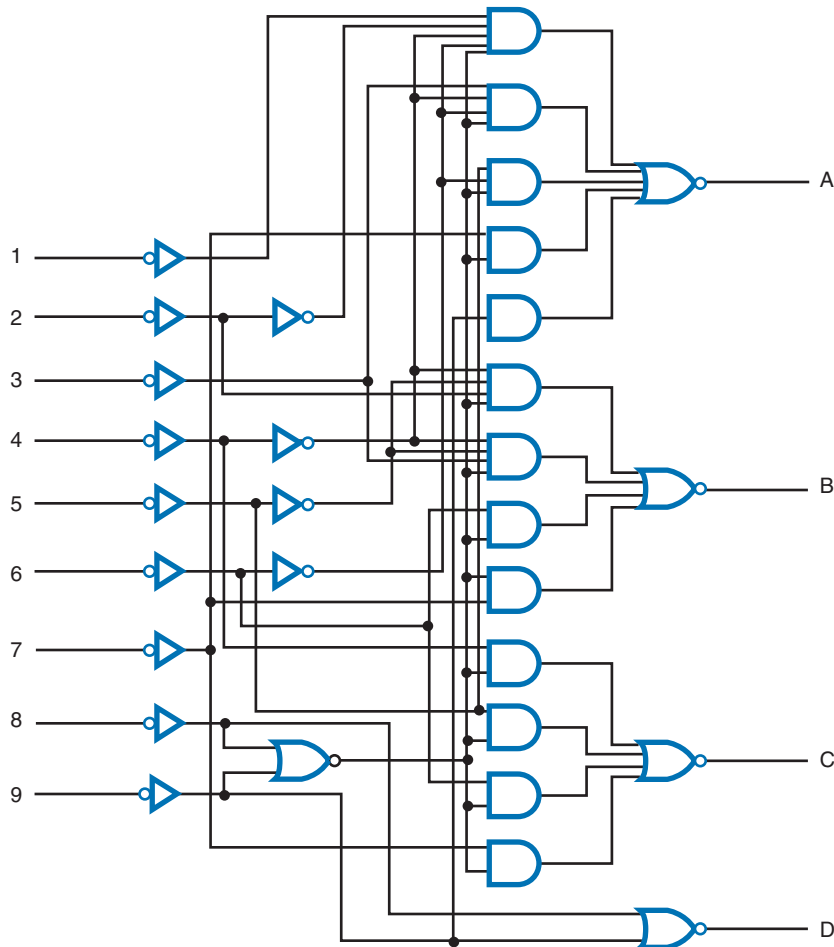
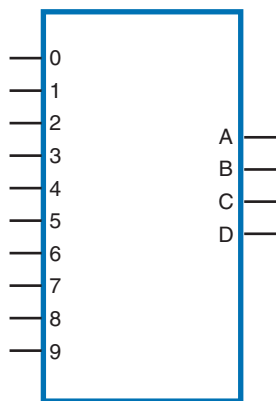


FIGURE 36-3

Logic symbol for a decimal-to-binary priority encoder.



36-1 QUESTIONS

1. What is encoding?
2. What does an encoder accomplish?
3. What is the difference between a normal encoder and a priority encoder?
4. Draw the logic symbol for a decimal-to-binary priority encoder.
5. What are applications of decimal-to-binary encoders?

36-2 DECODERS

A **decoder** is one of the most frequently used combinational logic circuits. It processes a complex binary logic circuits. It processes a complex binary code into a recognizable digit or character. For example, it might decode a BCD number into one of the ten possible decimal digits. The output of such a decoder is used to operate a decimal number readout or display. This type of decoder is called a 1-of-10 decoder or a 4-line-to-10-line decoder.

Figure 36-4 shows the ten NAND gates required for decoding a 4-bit BCD number to its approximate output (one decimal digit). When all the inputs to a NAND gate are 1, its output is 0.

FIGURE 36-4

Binary-to-decimal decoder.

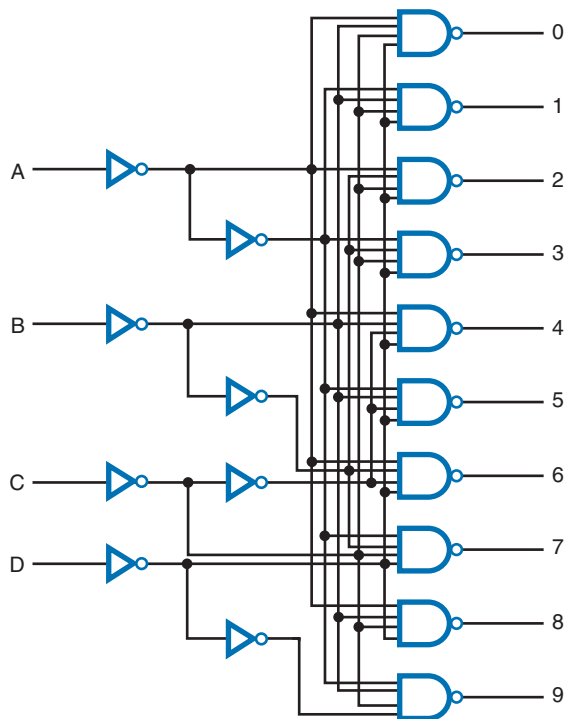
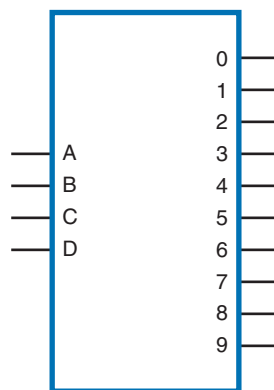


FIGURE 36-5

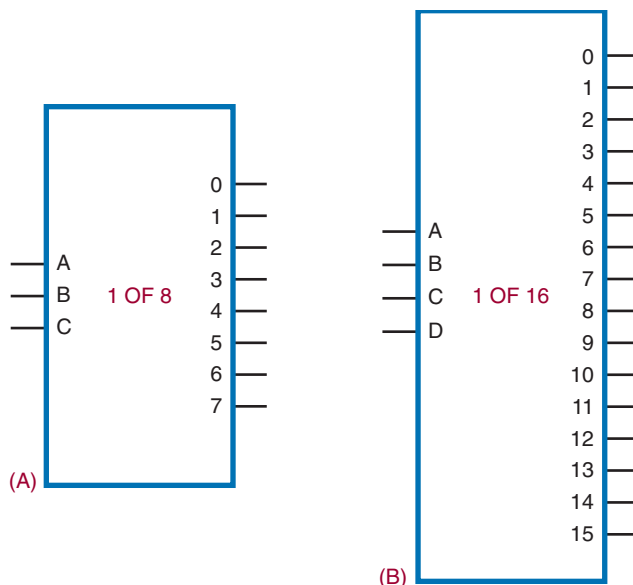
Logic symbol for a binary-to-decimal decoder.



All other outputs from the NAND gates in the decoder are 1's. Rather than draw all the logic gates each time the circuit is used, the symbol shown in Figure 36-5 is used.

FIGURE 36-6

Logic symbols for a 1-of-8 decoder (A) and a 1-of-16 decoder (B).



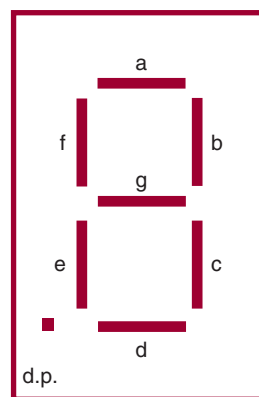
Two other types of decoder circuits are the 1-of-8 (octal, or base 8) decoder and the 1-of-16 (hexadecimal, or base 16) decoder (Figure 36-6). The 1-of-8 decoder accepts a 3-bit input word and decodes it to one of eight possible outputs. The 1-of-16 decoder activates one of sixteen output lines by a 4-bit code word. It is also called a 4-line-to-16-line decoder.

A special type of decoder is the standard 8421 BCD-to-seven-segment decoder. It accepts a BCD input code and generates a special 7-bit output code to energize a seven-segment decimal readout display (Figure 36-7). The display consists of seven LED segments that are lit in different combinations to produce each of the ten decimal digits, 0 through 9 (Figure 36-8). Besides seven-segment LED displays, there are incandescent and liquid crystal (LCD) displays.

Each of these displays operates on the same principle. A segment is activated by either a high or low voltage level. Figure 36-9 shows two types of LED displays: a common anode and a common

FIGURE 36-7

Seven-segment display configuration.



cathode. In each case, the LED segment has to be forward biased for light to be emitted. For a common cathode, a high (1) lights up the segment, a low (0) does not.

Figure 36-10 shows the decoding logic circuit required to produce the output for a seven-segment

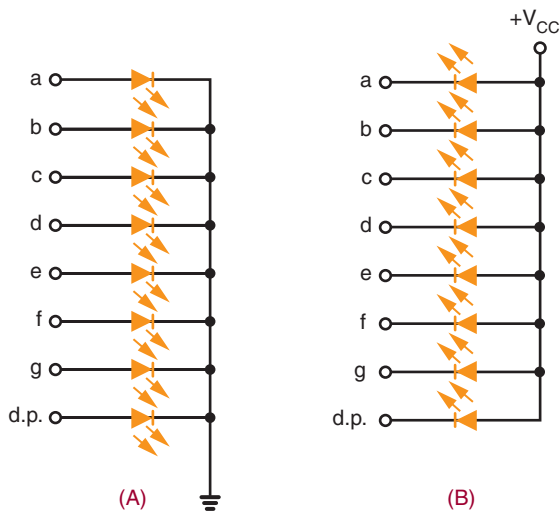
FIGURE 36-8

Using the seven-segment display to form the ten decimal digits.



FIGURE 36-9

Differences between the two types of LED displays: a common cathode (A), and a common anode (B).



display with a BCD input. Referring to Figure 36-7, notice that segment a is activated for digits 0, 2, 3, 5, 7, 8, and 9; segment b is activated for digits 0, 1, 2, 3, 4, 7, 8, and 9; and so on. Boolean expressions can be formed to determine the logic circuitry needed to drive each segment of the display. The logic symbol for a BCD-to-seven-segment decoder is shown in Figure 36-11. This represents the circuit contained in an integrated circuit.

36-2 QUESTIONS

1. What is a decoder?
2. What are the uses of decoders?

3. Draw the logic symbol for a 1-of-10 decoder.
4. What is the purpose of a seven-segment decoder?
5. What codes can be used in decoders?

36-3 MULTIPLEXERS

A **multiplexer** is a circuit used to select and route any one of several input signals to a single output. An example of a nonelectronic circuit multiplexer is a single-pole, multiposition switch (Figure 36-12).

Multiposition switches are widely used in many electronic circuits. However, circuits that operate at high speed require the multiplexer to switch at high speed and to be automatically selected. A mechanical switch cannot perform this task satisfactorily. Therefore, multiplexers used to perform high-speed switching are constructed of electronic components.

Multiplexers handle two basic types of data: analog and digital. For analog applications, multiplexers are built of relays and transistor switches. For digital applications, multiplexers are built from standard logic gates.

Digital multiplexers allow digital data from several individual sources to be routed through a common line for transmission to a common destination. A basic multiplexer has several input lines with a single output line. The input lines are activated by data selection input that identifies the line the data are to be received on.

FIGURE 36-10

Binary-to-seven-segment display decoder.

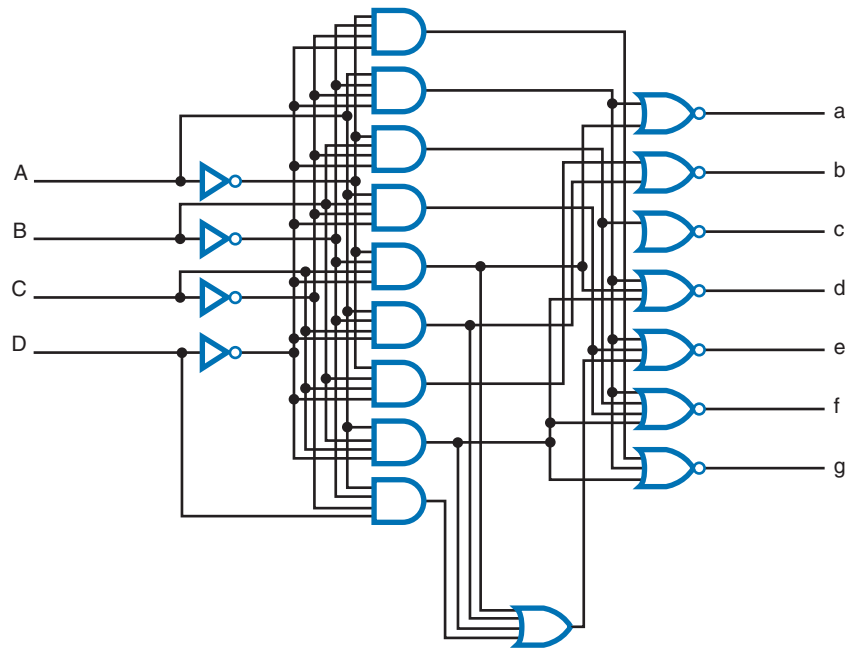


FIGURE 36-11

Logic symbol for a BCD-to-seven-segment decoder.

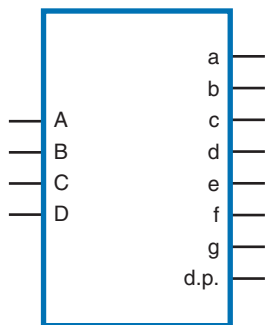


Figure 36-13 shows the logic circuit for an eight-input multiplexer. Notice that there are three input-control lines, labeled A, B, and C. Any of the eight input lines can be selected by the proper expression of the input-control line. The symbol used to represent a digital multiplexer is shown in Figure 36-14.

FIGURE 36-12

A single-pole, multiposition switch can be used as a multiplexer.

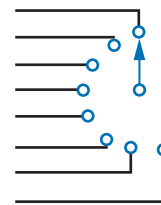


Figure 36-15 shows the symbol for a 1-of-16 multiplexer. Notice that there are four input-control lines to activate the sixteen data input lines.

In addition to data line selection, a common application of a multiplexer is parallel-to-serial data conversion. A parallel binary word is applied to the input of the multiplexer. Then, by sequencing through the enabling codes, the output becomes a serial representation of the parallel input word.

FIGURE 36-13

Logic circuit for an eight-input multiplexer.

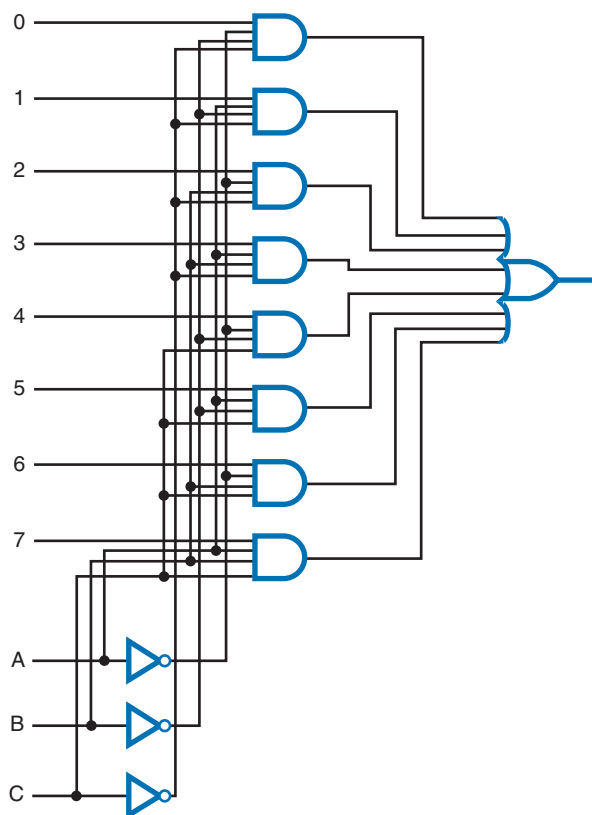


FIGURE 36-14

Logic symbol for an eight-input multiplexer.

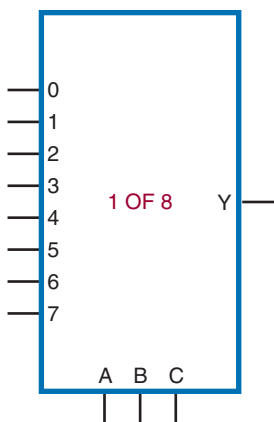


FIGURE 36-15

Logic symbol for a sixteen-input multiplexer.

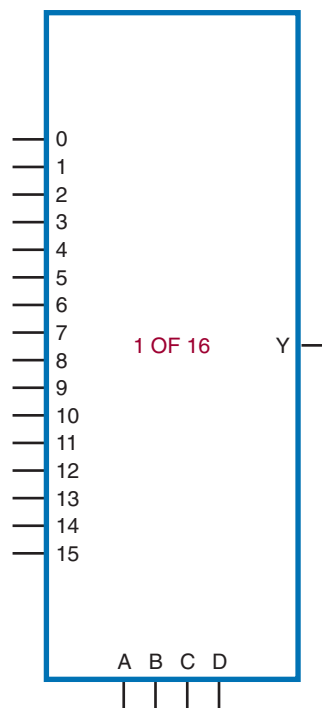


FIGURE 36-16

Using a multiplexer for parallel-to-serial conversion.

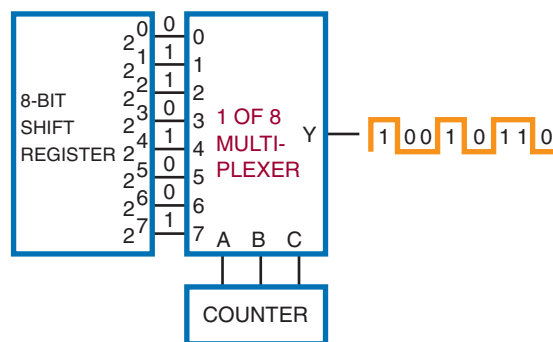


Figure 36-16 shows a multiplexer set up for parallel-to-serial conversion. A 3-bit binary input word from a counter is used to select the desired input. The parallel input word is connected to each of the input lines of the multiplexer. As the counter is

incremented, the input select code is sequenced through each of its states. The output of the multiplexer is equal to the parallel signal applied.

36-3 QUESTIONS

1. What is a multiplexer?
2. How are multiplexers used?
3. Draw a logic diagram for a multiplexer.
4. What type of data can a multiplexer handle?
5. How can a multiplexer be set up for parallel to serial conversion?

36-4 ARITHMETIC CIRCUITS

ADDER

An **adder** is the primary computation unit in a digital computer. Few routines are performed by a computer in which the adder is not used. Adders are designed to work in either serial or parallel circuits. Because the parallel adder is faster and used more often, it is covered in more detail here.

To understand how an adder works it is necessary to review the rules for adding:

$$\begin{array}{r}
 0 \quad 0 \quad 1 \quad 1 \\
 +0 \quad +1 \quad +0 \quad +1 \\
 \hline
 0 \quad 1 \quad 1 \quad \text{Carry 1} \quad 0
 \end{array}$$

Figure 36-17 shows a truth table based on these rules. Note that the Greek letter sigma (Σ) is used to represent the sum column. The carry column is represented by C_0 . These terms are used by industry when referring to an adder.

The sum column of the truth table is the same as the output column in the truth table of an exclusive OR gate (Figure 36-18). The carry column is the same as the output in a truth table for an AND gate (Figure 36-19).

FIGURE 36-17

Truth table constructed using addition rules.

INPUTS		OUTPUTS	
A	B	Σ	C_0
0	0	0	0
1	0	1	0
0	1	1	0
1	1	0	1

FIGURE 36-18

Truth table for an exclusive OR gate.



A	B	Y
0	0	0
1	0	1
0	1	1
1	1	0

FIGURE 36-19

Truth table for an AND gate.



A	B	Y
0	0	0
1	0	0
0	1	0
1	1	1

Figure 36-20 shows an AND gate and an exclusive OR gate connected in parallel to provide the necessary logic function for single-bit addition. The carry output (C_0) is produced with the AND gate, and the sum output (Σ) is produced

FIGURE 36–20

Half-adder circuit.

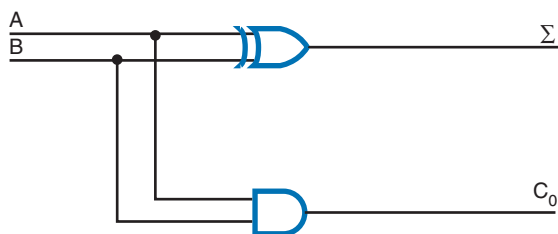


FIGURE 36–21

Truth table for a full adder.

INPUTS			OUTPUTS	
A	B	C_{IN}	Σ	C_0
0	0	0	0	0
1	0	0	1	0
0	1	0	1	0
1	1	0	0	1
0	0	1	1	0
1	0	1	0	1
0	1	1	0	1
1	1	1	1	1

with the XOR gate. The inputs A and B are connected to both the AND gate and the XOR gate. The truth table for the circuit is the same as the truth table developed using the binary addition rules (Figure 36–17). Because the circuit does not take into account any carries, it is referred to as a **half adder**. It can be used as the LSB adder for a binary addition problem.

An adder that takes into account the carry is called a **full adder**. A full adder accepts three inputs and generates a sum and carry output. Figure 36–21 shows the truth table for a full adder. The C_1 input represents the carry input. The C_0 output represents the carry output.

FIGURE 36–22

Logic circuit for a full adder using two half adders.

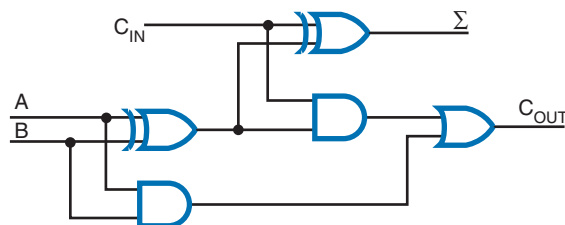


FIGURE 36–23

Logic symbols for half adder (A) and full adder (B).

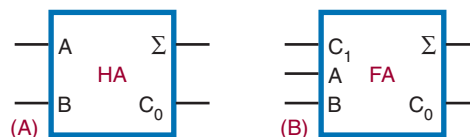


Figure 36–22 shows a full adder constructed of two half adders. The results of the first half adder are “OR”ed with the second half adder to form the carry output. The carry output is a 1 if both inputs to the first XOR gate are 1’s or if both inputs to the second XOR gate are 1’s. Figure 36–23 shows the symbols used to represent a half adder and a full adder.

A single full adder is capable of adding two single-bit numbers and an input carry. To add binary numbers with more than 1-bit, additional full adders must be used. Remember, when one binary number is added to another, each column that is added generates a sum and a carry of 1 or 0 to the next higher-order column. To add two binary numbers, a full adder is required for each column. For example, to add a 2-bit number to another 2-bit number, two adders are required. Two 3-bit numbers require three adders, two 4-bit numbers require four adders, and so on. The carry generated by each adder is applied to the input of the next higher-order adder. Because no carry input is required for the least significant position, a half adder is used.

FIGURE 36–24
Four-bit parallel adder.

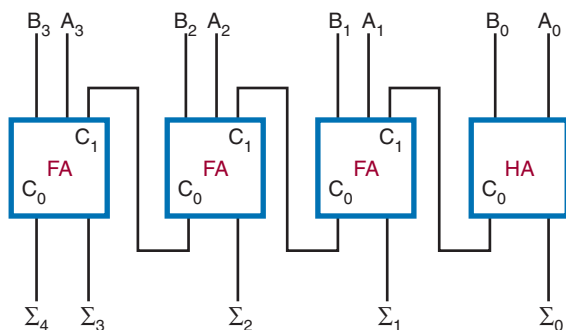


Figure 36–24 shows a 4-bit parallel adder. The least significant input bits are represented by A_0 and B_0 . The next higher-order bits are represented by A_1 and B_1 and so on. The output sum bits are identified as Σ_0 , Σ_1 , Σ_2 and so on. Note that the carry output of each adder is connected to the carry input of the next higher-order adder. The carry output of the final adder is the most significant bit of the answer.

SUBTRACTOR

A **subtractor** allows subtraction of two binary numbers. To understand how a subtractor works it is necessary to review the rules for subtraction.

$$\begin{array}{r} 0 \quad \text{Borrow 1} \quad 0 \quad 1 \quad 1 \\ - \underline{0} \quad \quad \quad - \underline{1} \quad - \underline{0} \quad - \underline{1} \\ 0 \quad \quad \quad 1 \quad 1 \quad 0 \end{array}$$

Figure 36–25 shows a truth table based on these rules. The letter D represents the difference column. The borrow column is represented by B_0 .

Notice that the difference output (D) is 1 only when the input variables are not equal. Therefore, the difference can be expressed as the exclusive OR of the input variables. The output borrow is generated only when A is 0 and B is 1. Therefore, the borrow output is the complement of A “AND”ed with B .

FIGURE 36–25
Truth table constructed using subtraction rules.

INPUTS		OUTPUTS	
A	B	D	B_0
0	0	0	0
1	0	1	0
0	1	1	1
1	1	0	0

FIGURE 36–26
Logic circuit for a half subtractor.

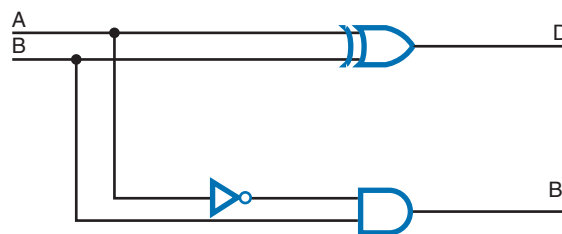


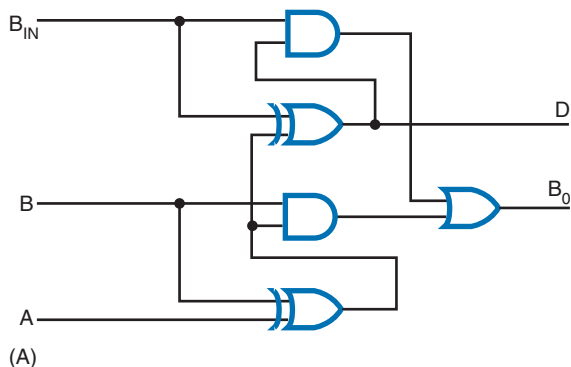
Figure 36–26 shows a logic diagram of a **half subtractor**. It has two inputs and generates a difference and a borrow output. The difference is generated by an XOR gate and the borrow output is generated by an AND gate with A and B inputs. The A is achieved by using an inverter on the variable A input.

However, a half subtractor is identified as such because it does not have a borrow input. A **full subtractor** does. It has three inputs and generates a difference and a borrow output. A logic diagram and truth table for a full subtractor are shown in Figure 36–27. Figure 36–28 shows the symbols used to represent a half subtractor and full subtractor.

A full subtractor can handle only two 1-bit numbers. To subtract binary numbers with more than 1 bit, additional full subtractors must be used. Keep in mind that if a 1 is subtracted from a 0, a borrow must be made from the next higher-order column. The output borrow of the lower-order

FIGURE 36-27

Logic circuit (A) and truth table (B) for a full subtractor.

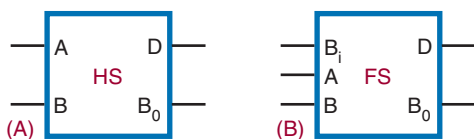


INPUT			OUTPUT	
A	B	B_{IN}	D	B_0
0	0	0	0	0
1	0	0	1	0
0	1	0	1	1
1	1	0	0	0
0	0	1	1	1
1	0	1	0	0
0	1	1	0	1
1	1	1	1	1

(B)

FIGURE 36-28

Logic symbols for half subtractors (A) and full subtractors (B).



subtractor becomes the input borrow of the next higher-order subtractor.

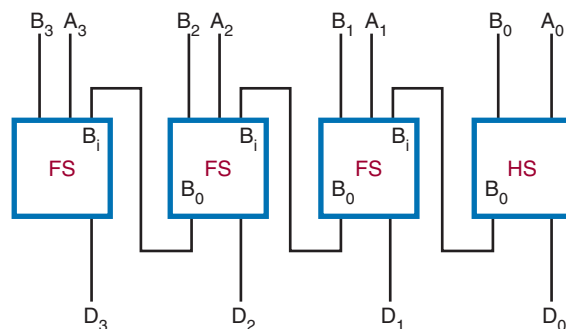
Figure 36-29 shows a block diagram of a 4-bit subtractor. A half subtractor is used in the least significant bit position because there is no input borrow.

COMPARATOR

A **comparator** is used to compare the magnitudes of two binary numbers. It is a circuit used simply to determine if two numbers are equal. The output not only compares two binary numbers but

FIGURE 36-29

Four-bit subtractor.



also indicates whether one is larger or smaller than the other.

Figure 36-30 shows a truth table for a comparator. The only time an output is desired is when both bits being compared are the same. The output column represents an exclusive OR with an inverter, also known as an exclusive NOR

FIGURE 36–30

Truth table for a comparator.

INPUT		OUTPUT
A	B	Y
0	0	1
1	0	0
0	1	0
1	1	1

FIGURE 36–31

Comparing two 2-bit numbers.

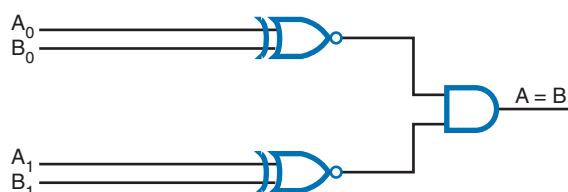
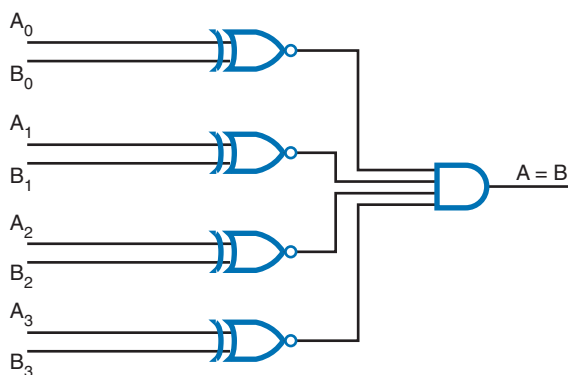


FIGURE 36–32

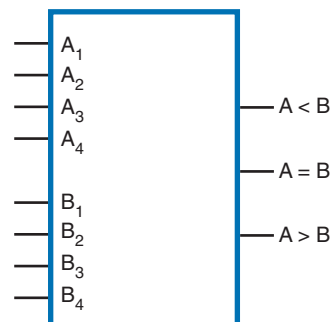
Comparing two 4-bit numbers.



(XNOR) gate. An XNOR gate is essentially a comparator, because its output is a 1 only if the two inputs are the same. To compare numbers containing 2 bits or more, additional XNOR gates are necessary. Figure 36–31 shows a logic diagram of

FIGURE 36–33

Diagram of a 4-bit comparator.



a comparator for checking two 2-bit numbers. If the numbers are equal, a 1 is generated from the XNOR gate. The 1 is applied to the AND gate as a qualifying level. If both XNOR gates produce a 1 for the inputs to the AND gate, that identifies the numbers as equal and generates a 1 for the output of the AND gate. However, if the inputs to the XNOR gate are different, the XNOR gate generates a 0, which disqualifies the AND gate. The output of the AND gate is then a 0. Figure 36–32 shows a logic diagram of a comparator for checking two 4-bit numbers. Figure 36–33 is the diagram used to represent a 4-bit comparator.

36–4 QUESTIONS

1. What are the rules for binary addition?
2. What is the difference between a half adder and a full adder?
3. When is a half adder used?
4. What are the rules for binary subtraction?
5. Draw a block diagram of a 4-bit subtractor.
6. What is the function of a comparator?
7. Draw a logic diagram of a comparator.

36-5 PROGRAMMABLE LOGIC DEVICES (PLDs)

In Chapter 34 complex switching functions were reduced to the simplest circuit possible using Veitch diagrams or Karnaugh maps. For example:

$$\bar{A}BCD + \bar{A}\bar{B}CD + \bar{A}BC\bar{D} + \bar{A}\bar{B}C\bar{D} + A\bar{B}CD + A\bar{B}C\bar{D} = Y$$

reduced to its simplest form became:

$$\bar{A}D + A\bar{B}C = Y$$

To implement this expression using conventional logic gates would require several ICs. As the complexity of the circuit increases, the number of ICs become excessive.

A solution that is becoming popular requires the use of programmable logic devices (PLDs) to

implement the logic function. PLDs can be selected from any of the IC families depending on the speed, power, and logic functions required.

There are three basic forms of PLDs available. They are programmable read-only memory (PROM), programmable array logic (PAL[®]), and programmable logic array (PLA). PROMs are used primarily as a storage device and are not well adapted to implementing complex logic equations.

PALs have several multi-input AND gates connected to the input of an OR gate and inverter (Figure 36-34). The inputs are set up as a fusible-link array. By blowing specific fuses in an array, the PAL can be programmed to solve a variety of complex logic equations.

The PLA is similar to the PAL but has the additional flexibility of having its AND gates connected to several programmable OR gates. This results in a device that is harder to program than

FIGURE 36-34

Programmable array logic (PAL) architecture.

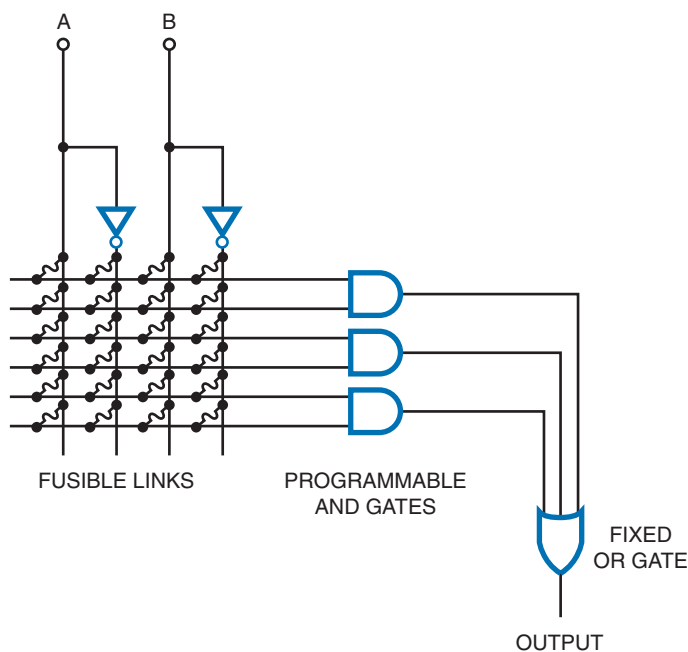
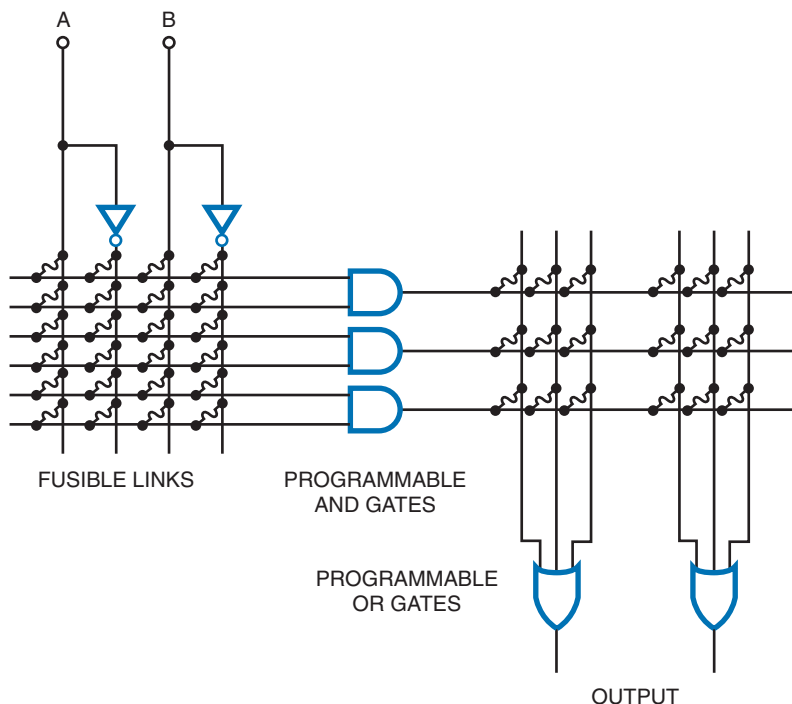


FIGURE 36–35

Programmable logic array (PLA) architecture.



the PAL, but the additional level of logic gates increases the overall propagation delay time. Figure 36–35 shows the detailed interconnections. The interconnections start with all fusible links in place. The programmer decides which fuses will be left intact and which will be blown. The links are blown to represent a logic equation.

The main difference between PALs and PLAs is that PALs have fixed (hard-wired) OR gates and PLAs have programmable OR gates.

36–5 QUESTIONS

1. What is the purpose of a programmable logic device?
2. What are the three forms of programmable logic devices?

3. Explain how to program a PAL.

4. Draw the PLA schematic circuit that will produce the following expression:

$$Y = \bar{A}B + A\bar{B} + \bar{A}\bar{B}$$

5. Describe how a PAL differs from a PLA.

SUMMARY

- An encoder accepts one or more inputs and generates a multibit binary output.
- A decimal-to-binary encoder takes a single digit (0 through 9) and produces a 4-bit output code that represents the digit.
- A priority encoder accepts the higher-order key when two keys are pressed simultaneously.

- Decimal-to-binary encoders are used for keyboard encoding.
- A decoder processes a complex binary code into a digit or character that is easy to recognize.
- A BCD-to-seven-segment decoder is a special-purpose decoder to drive seven-segment displays.
- A multiplexer allows digital data from several sources to be routed through a common line for transmission to a common destination.
- Multiplexers can handle both analog and digital data.
- Multiplexers can be hooked up for parallel-to-serial conversion of data.
- The truth table for the adding rules of binary numbers is equivalent to the truth table for an AND gate and an XOR gate.
- A half adder does not take into account the carry.
- A full adder takes the carry into account.
- To add two 4-bit numbers requires three full adders and one half adder.
- The truth table for the subtracting rules of binary numbers is equivalent to the truth table for an AND gate with an inverter on one of the inputs and an XOR gate.
- A half subtractor does not have a borrow input.
- A full subtractor has a borrow input.
- A comparator is used to compare the magnitudes of two binary numbers.
- A comparator generates an output only when the two bits being compared are the same.
- A comparator can also determine whether one number is larger or smaller than the other.
- Programmable logic devices (PLDs) are used to implement complex logic functions.
- Three types of PLDs are PROMs, PALs, and PLAs.
- PLAs are similar to PALs except that PALs have fixed OR gates and PLAs have programmable OR gates.

CHAPTER 36 SELF-TEST

1. Why are encoders necessary in logic circuits?
2. What type of encoder is required for keyboard input?
3. Why are decoders important in logic circuits?
4. What are the applications for the different types of decoders?
5. Briefly describe how a digital multiplexer works.
6. For what applications can a digital multiplexer be used?
7. Draw a schematic using logic symbols for a half adder and full adder tied together for two-bit addition.
8. Explain the operation of the adder drawn in question 7.

Microcomputer Basics

OBJECTIVES

After completing this chapter, the student will be able to:

- Identify the basic blocks of a digital computer.
- Explain the function of each block of a digital computer.
- Describe what a program is and its relationship to both digital computers and microprocessors.
- Identify the basic registers in a microprocessor.
- Explain how a microprocessor operates.
- Identify the instruction groups associated with microprocessors.

The greatest application of digital circuits is in digital computers. A *digital computer* is a device that automatically processes data using digital techniques. Data are pieces of information. Processing refers to the variety of ways that data can be manipulated.

Digital computers are classified by size and computing power. The largest computers are called *mainframes*. These computers are expensive, having extensive memory and high-speed calculating capabilities. Smaller-scale computers—the minicomputer and the microcomputer—are more widely used. Even though they represent a small percentage of the total computer dollars invested, small-scale computers represent the largest number of computers in use. The *microcomputer* is the smallest and least expensive of the digital computers that still retains all the features and characteristics of a computer.

Computers are also classified by function. The most common function is data processing. Industry, business, and government use computers to maintain records, perform accounting tasks, keep inventory, and provide a wide variety of other data processing functions.

Computers can be general purpose or special purpose. General-purpose computers are flexible and can be programmed for any task. Special-purpose, or dedicated, computers are designed to perform a single task.

37-1 COMPUTER BASICS

All **digital computers** consist of five basic blocks or sections: **control**, **arithmetic logic unit (ALU)**, **memory**, **input**, and **output** (Figure 37-1). In some cases the input and output blocks are a single block identified as **input/output (I/O)**. Because the control unit and the arithmetic logic unit are closely related and difficult to separate, they may be collectively referred to as the central processing unit (CPU) or microprocessing unit (MPU).

The *control unit* decodes each instruction that enters the computer. It then generates the necessary pulses to carry out the functions specified. If, for example, an instruction requires two numbers to be added together, the control unit sends pulses to the arithmetic logic unit (ALU) to perform the addition. If the instruction re-

quires a word to be stored in memory, control sends the necessary pulses to memory to store the data.

Modern computers utilize a means of incorporating several instructional commands into a single input instruction. This is accomplished by a program stored in memory. When the instruction is decoded by the control unit, it causes a sequence of instructions to be executed.

The control unit varies from computer to computer. Basically, the control unit consists of an address register, an instruction register, an instruction decoder, a program counter, a clock, and circuitry for generating the control pulses (Figure 37-2).

The instruction register stores the instruction word to be decoded. The word is decoded by the instruction decoder, which sends the appropriate logic signal to the control pulse generator. The control pulse generator produces a pulse when the appropriate clock signal is given. The output of the control pulse generator enables other circuitry in the computer to carry out the specific instruction.

The program counter keeps track of the sequence of instructions to be executed. The instructions are stored in a program in memory. To begin the program, the starting address (specific memory location) of the program is placed in the program counter. The first instruction is read from memory, decoded, and performed. The program counter then automatically moves to the next instruction location. Each time an instruction is fetched and executed, the program counter advances one step until the program is completed.

FIGURE 37-1
Basic blocks of a digital computer.

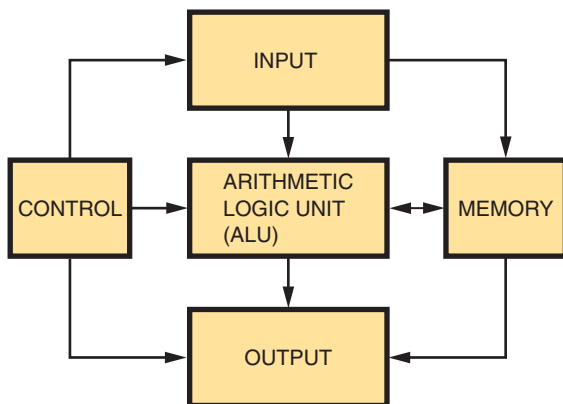
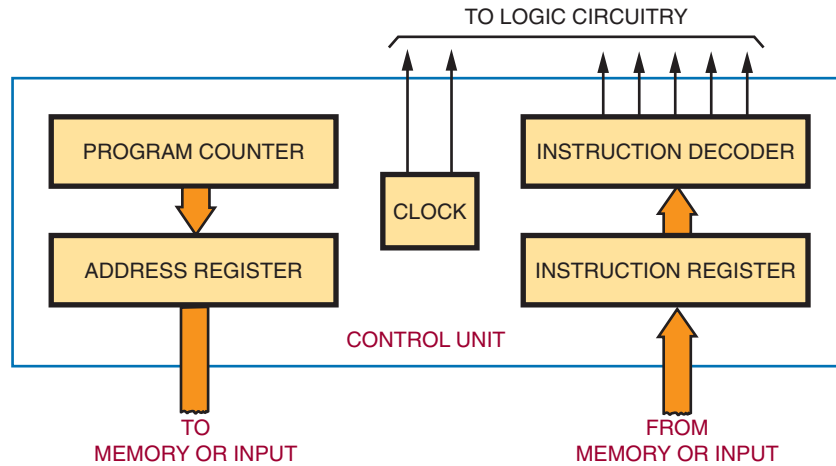


FIGURE 37-2

Control unit of a computer.



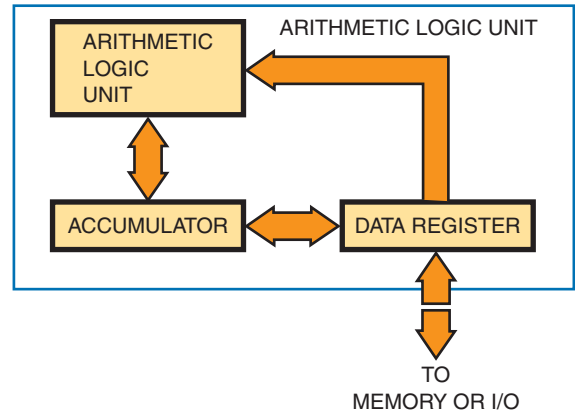
Some instructions specify a jump or branch to another location in the program. The instruction register contains the address of the next instruction location and it is loaded into the address register.

The ALU performs math logic and decision-making operations. Most arithmetic logic units can do addition and subtraction. Multiplication and division are programmed in the control unit. The arithmetic logic unit can perform logic operations such as inversion, AND, OR, and exclusive OR. It can also make decisions by comparing numbers or test for specific quantities such as 0's, 1's, or negative numbers.

Figure 37-3 shows an arithmetic logic unit. It consists of arithmetic logic circuitry and an accumulator register. All data to the accumulator and the ALU are sent via the data register. The accumulator register can be incremented (increased by one), decremented (decreased by one), shifted right (one position), or shifted left (one position). The accumulator is the same size as the memory word; the memory word is 32 bits wide, and the accumulator is also 32 bits wide in an 32-bit microprocessor.

FIGURE 37-3

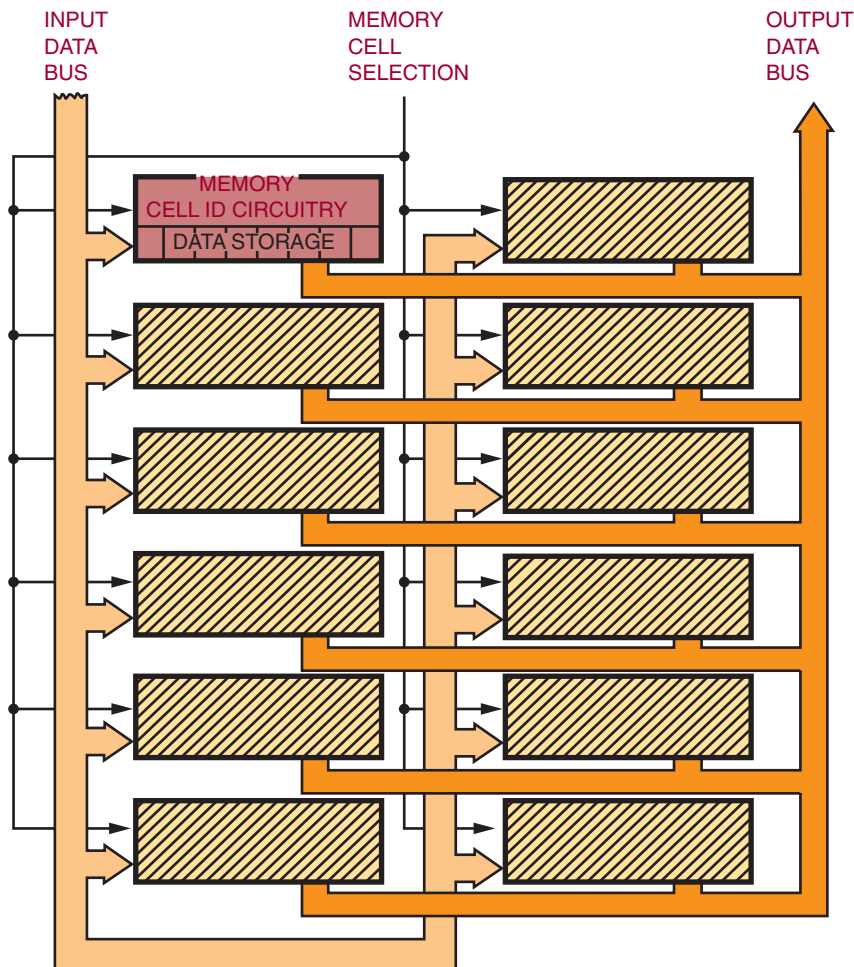
Arithmetic logic unit (ALU).



The arithmetic logic circuitry is basically a binary adder. Both addition and subtraction can be done with the binary adder as well as logic operations. To add two binary numbers, one number is stored in the accumulator register and the other is stored in the data register. The sum of the two numbers is then placed in the accumulator register, replacing the original binary number.

FIGURE 37-4

Memory layout for a computer.



Memory is the area where programs are stored. *Programs* contain the instructions that tell the computer what to do. A program is a sequential set of instructions to solve a particular problem.

A computer memory is simply a number of storage registers. Data can be loaded into the registers and then taken out, or “read out” to perform some operation, without losing the register content. Each register or memory location is assigned a number called an address. The address is used to locate data in memory.

Figure 37-4 shows a typical memory layout. The memory registers retain the binary data. This memory, based on its ability to store (write) or retrieve (read) data, is usually referred to as random-access read or write memory (RAM). Based on the ability of being able to read only data or instruction from the memory, it is referred to as read-only memory (ROM).

The memory address register allows access to specific memory locations by the memory address decoder. The size of the memory address

register determines the maximum memory size for a computer. For example, a memory address register of 16 bits allows a maximum number of 2^{16} or 65,536 memory locations.

A word to be stored in memory is located in the data register and then placed in the desired memory location. To read data from memory, the memory location is determined, and data at the memory location are loaded into the shift register.

The input and output units of a computer allow it to receive and transmit information from and to the world outside the computer. An operator or peripheral equipment enters data into a computer through the input unit. Data from the computer are passed to external peripheral equipment through the output unit.

The input and output units are under the control of the CPU. Special input/output (I/O) instructions are used to transfer data in and out of the computer.

Most digital computers can perform I/O operations at the request of an interrupt. An *interrupt* is a signal from an external device requesting service in the form of receiving or transmitting data. The interrupt results in the computer leaving the current program and jumping to another program. When the interrupt request is accomplished, the computer returns to the original program.

37-1 QUESTIONS

1. Draw and label a block diagram of a digital computer.
2. What is the function of the following blocks in a digital computer?
 - a. Control
 - b. Arithmetic logic unit
 - c. Memory
 - d. Input
 - e. Output
3. What is the function of ROM in a computer?

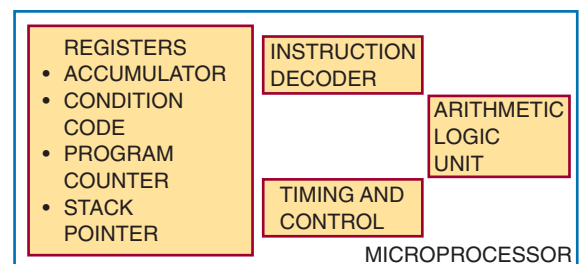
4. What keeps track of the sequence of instructions to be executed?
5. What determines how much data can be stored in a computer?
6. Define a *program*.

37-2 MICROPROCESSOR ARCHITECTURE

A **microprocessor** is the heart of a microcomputer. It contains four basic parts: registers, arithmetic logic unit, timing and control circuitry, and decoding circuitry. A microprocessor is designed so that an instruction, or program, can be fetched from memory, placed in the instruction register, and decoded. The timing, control, and decoding circuitry are all affected by the program. The program allows the operator to route data in or out of various registers or into the arithmetic logic unit. The registers and the arithmetic logic unit are used by the microprocessor for data or information manipulation.

Each microprocessor is different in its architecture and its instruction set. Figure 37-5 shows the basic parts of many of the 8-bit microprocessors. Because the names and number of registers vary from one microprocessor to the next, they are shown and identified separately.

FIGURE 37-5
Parts of an 8-bit microprocessor.



The **accumulator** is the register most often used in the microprocessor. It is used to receive or store data from memory or an I/O device. It also works closely with the arithmetic logic unit. The number of bits in the accumulator determines the microprocessor's word size. In an 8-bit microprocessor the word size is 8 bits.

The **condition-code register** is an 8-bit register that allows a programmer to check the status of the microprocessor at a certain point in a program. Depending on the microprocessor, the name of the condition-code register may be the processor-status register, the P-register, the status register, or the flag register. An individual bit in the condition-code register is called a flag bit. The most common flags are carry, zero, and sign. The carry flag is used during an arithmetic operation to determine whether there is a carry or a borrow. The zero flag is used to determine whether the results of an instruction are all zeros. The sign flag is used to indicate whether a number is positive or negative. Of the 8 bits in the code register, the Motorola 6800 and the Zilog Z80 use 6 bits; the Intel 8080A uses 5; the MOS Technology 6502 uses 7.

The **program counter** is a 16-bit register that contains the address of the instruction fetched from memory. While the instruction is being carried out, the program counter is incremented by

one for the next instruction address. The program counter can only be incremented. However, the sequence of the instructions can be changed by the use of branch or jump instructions.

The **stack pointer** is a 16-bit register that holds the memory location of data stored in the stack. The stack is discussed further later in the chapter.

Most microprocessors have the same basic set of instructions with different machine codes and a few unique instructions. The basic instructions fall into nine categories:

1. Data movement
2. Arithmetic
3. Logic
4. Compare and test
5. Rotate and shift
6. Program control
7. Stack
8. Input/output
9. Miscellaneous

Data movement instructions move data from one location to another within the microprocessor and memory (Figure 37–6). Data are moved eight bits at a time, in a parallel fashion (simultaneously), from the source to the destination specified. Microprocessor instructions use a symbolic notation that refers to how the data are moving.

FIGURE 37–6

Data movement instructions.

DESCRIPTION	MNEMONIC	NOTATION	SOURCE	DESTINATION
Load Accumulator	LDA	$M \rightarrow A$	Memory	Accumulator
Load X-Register	LDX	$M \rightarrow X$	Memory	X-Register
Store Accumulator	STA	$A \rightarrow M$	Accumulator	Memory
Store X-Register	STX	$X \rightarrow M$	X-Register	Memory
Transfer Accumulator to X-Register	TAX	$A \rightarrow X$	Accumulator	X-Register
Transfer X-Register to Accumulator	TXA	$X \rightarrow A$	X-Register	Accumulator

In the 6800 and 6502 microprocessor, the arrow moves from left to right. In the 8080A and the Z80, the arrow moves from right to left. In either case, the message is the same. The data move from the source to the destination.

Arithmetic instructions affect the arithmetic logic unit. The most powerful instructions are add, subtract, increment, and decrement. These instructions allow the microprocessor to compute and manipulate data. They differentiate a computer from a random logic circuit. The result of these instructions is placed in the accumulator.

Logic instructions are those instructions that contain one or more of the following Boolean operators: AND, OR, and exclusive OR. They are performed eight bits at a time in the ALU, and the results are placed in the accumulator. Another logic operation is the complement instruction. This includes both 1's and 2's complement. Because complementing is done with additional circuitry, it is not included in all microprocessors. The 6502 has neither complement instruction. The 8080A has a 1's complement instruction. The 6800 and the Z80 have both 1's and 2's complement.

Complementing provides a method of representing signed numbers. Complementing numbers allow the ALU to perform subtract operations using an adder circuit. Therefore, the MPU can use the same circuits for addition and subtraction.

Compare instructions compare data in the accumulator with data from a memory location or another register. The result of the comparison is not stored in the accumulator, but a flag bit might change as a result of it. Comparison may be performed by masking or bit-testing. *Masking* is a process of subtracting two numbers and allowing only certain bits through. The mask is a predetermined set of bits that is used to determine if certain conditions exist within the MPU. There is a disadvantage with the masking procedure because it uses an AND instruction and therefore destroys the content of the accumulator. The bit-testing procedure, although it also uses an AND instruction, does not destroy the content of the

accumulator. Not all microprocessors have a bit-testing instruction.

Rotate and shift instructions change the data in a register or memory by moving the data to the right or left one bit. Both instructions involve use of the carry bit. The difference between the instructions is that the rotate instruction saves the data and the shift instruction destroys the data.

Program-control instructions change the content of the program counter. These instructions allow the microprocessor to skip over memory locations to execute a different program or to repeat a portion of the same program. The instructions can be unconditional, where the content of the program counter changes, or conditional, where the state of a flag bit is first checked to determine whether the content of the program counter should change. If the condition of the flag bit is not met, the next instruction is executed.

Stack instructions allow the storage and retrieval of different microprocessor registers in the stack. The **stack** is a temporary memory location that is used for storing the contents of the program counter during a jump to a subroutine program. The difference between a stack and other forms of memory is the method in which the data is accessed or addressed. A push instruction stores the register content, and a pull instruction retrieves the register content. There is an advantage with the stack because data can be stored into it or read from it with single-byte instructions. All data transfers are between the top of the stack and the accumulator. That is, the accumulator communicates only with the top location of the stack.

In the 6800 and 6502 microprocessors, the content of the register is stored in the stack, and then the stack pointer is decremented by 1. This allows the stack pointer to point to the next memory location where data can be saved. The *stack pointer* is a 16-bit register that is used to define the memory location that acts as the top of the stack. When the pull instruction is used, the stack pointer is incremented by one, and the data are retrieved from the stack and placed in the appropriate register. In

the 8080A, the top of the stack contains the pointer to the last memory location. The push instruction first decrements the stack pointer by 1 and then stores the register content in the stack.

Input/output instructions deal specifically with controlling I/O devices. The 8080A, 8085, and Z80 have I/O instructions. The 6800 and 6502 do not have specific I/O instructions. If a microprocessor uses an I/O instruction to deal with external devices, the technique is called *isolated I/O*.

Some instructions do not fall in any of the categories mentioned. These instructions are grouped together and are called **miscellaneous instructions**. Among these instructions are those used to enable or disable interrupt lines, clear or set flag bits, or allow the microprocessor to perform BCD arithmetic. Also included is the instruction to halt or break the program sequence.

37-2 QUESTIONS

1. What are the basic parts of a microprocessor?
2. What registers are located in the microprocessor?
3. What are the major categories of microprocessor instructions?

37-3 MICROCONTROLLERS

Micro identifies the device as small. *Controller* identifies the device as being used to control objects, processes, or events.

Any device that measures, stores, controls, calculates, or displays information has a microcontroller inside. In today's society, microcontrollers control many appliances (e.g., microwaves, toasters, and stoves), operate high-tech toys and play music in greeting cards. Many of the devices they control are taken for granted today.

A microcontroller is a single-chip computer. It contains limited memory, input/output (I/O)

interfacing, and a central processing unit (CPU) on the chip (Figure 37-7). This makes it ideal for monitoring and controlling functions. Because it is on a chip, the microcontroller and its support circuits are often built into the device they control.

Microcontrollers are designed for machine-control applications and do not require human interaction to operate. For example, toasters and microwave ovens have one or two fixed, repetitive programs. A microcontroller does not require any human interface device such as a keyboard, monitor, or mouse.

One example of a microcontroller-integrated circuit is the 8051, an 8-bit processor with ROM and RAM located on the chip as well as the input/output circuitry. The 8051 is a popular chip that is being produced and developed by several companies. Intel's version of the 8051 chip is the MCS 251, which is fifteen times faster than the MCS 51. A block diagram of the MCS 51 is shown in Figure 37-8.

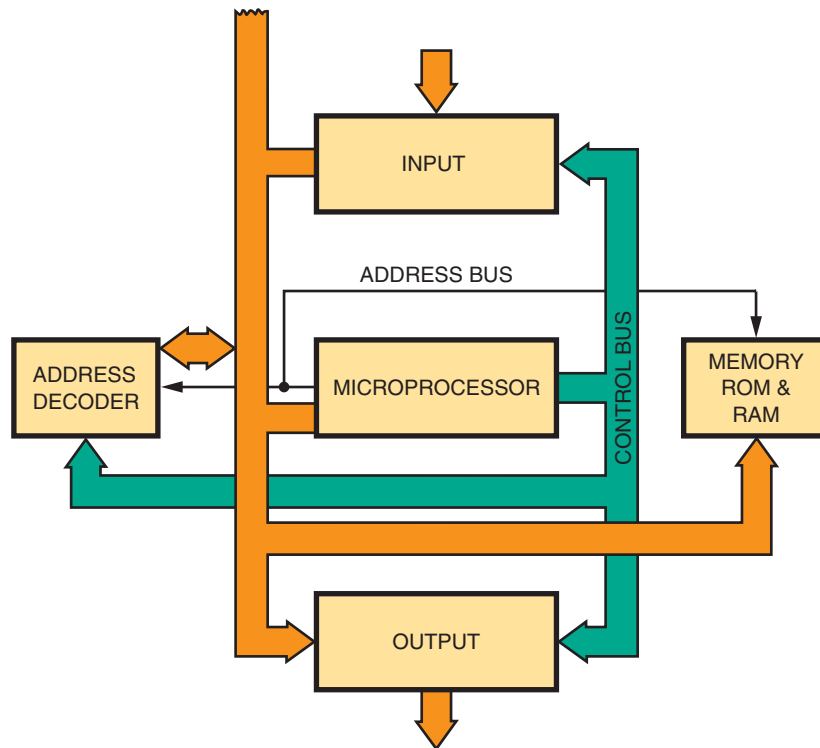
The MCS 51 features 4 kbytes of EPROM/ROM; 128 bytes of RAM; 32 input/out lines; two 16-bit timer/counters; five source-two-level interrupt structures; a full-duplex serial port; and an on-chip oscillator and clock circuitry.

The 68HC11 is a powerful 8-bit, 16-bit address microcontroller from Motorola. It has an instruction set that is similar to the older 68xx (6801, 6805, and 6809) family. Depending on the application, the 68HC11 comes with a variety of features including built-in windowed EPROM/EEPROM/OTPROM (one-time programmable), static RAM, digital I/O, timers, A/D converter, PWM generator, and synchronous and asynchronous communication channels. Motorola offers a low-cost evaluation board to explore the capabilities of the 68HC11.

Experimenter-type microcontrollers can be found in various publications and on the Internet. One particular type is the Basic Stamp by Parallax. The heart of the Basic Stamp 2 hybrid chip is a PIC16C57. The Basic Stamp is a microcontroller programmed in Basic. The unit requires minimal development equipment.

FIGURE 37-7

Block diagram of a microcontroller.

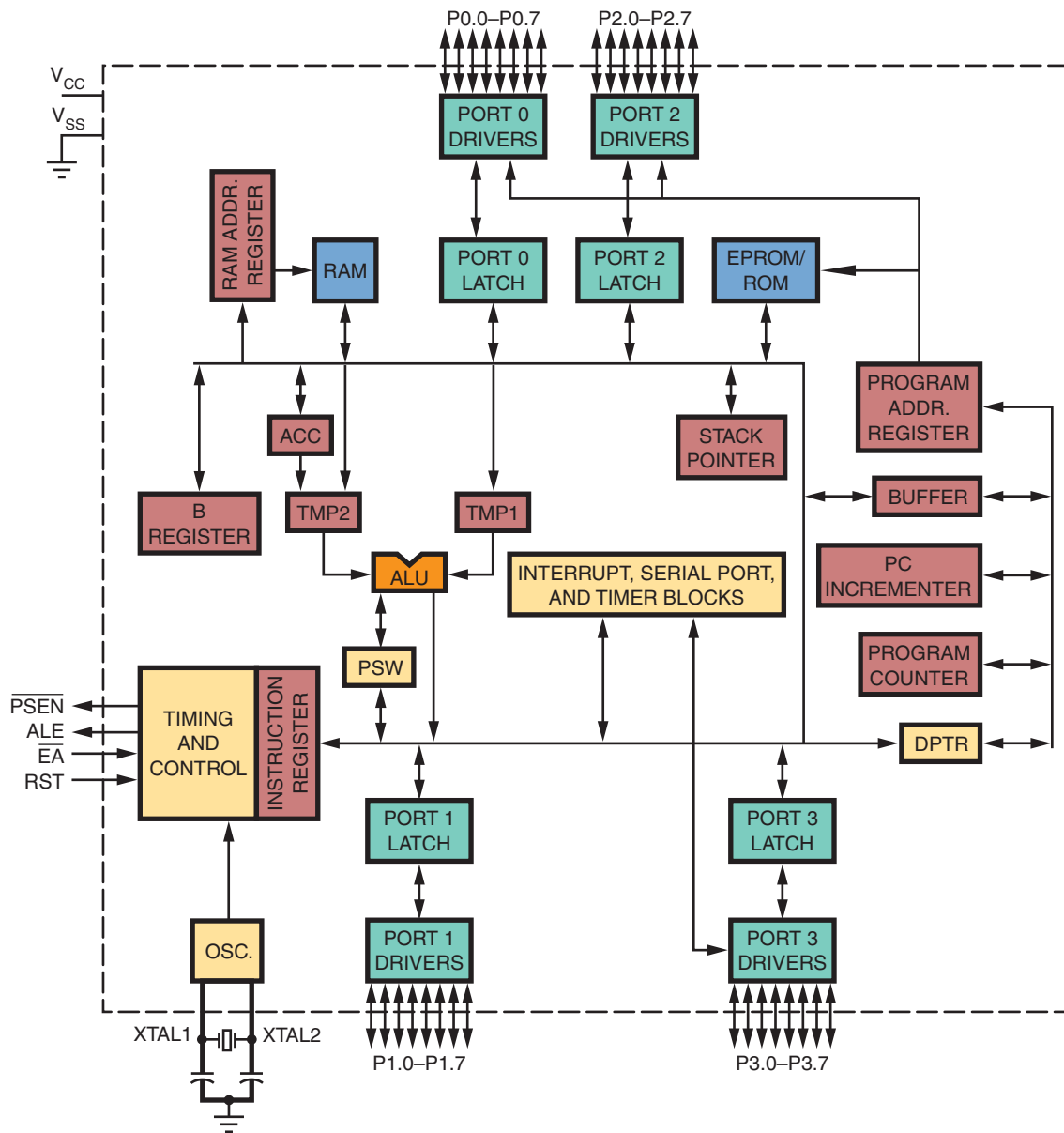


SUMMARY

- Digital computers consist of a control section, an arithmetic logic unit, memory, and an input/output section.
- The control section decodes the instructions and generates pulses to operate the computer.
- The arithmetic logic unit performs math, logic, and decision-making operations.
- Memory is an area where programs and data are stored while waiting for execution.
- The input/output units allow data to be transmitted into and out of the computer.
- The control section and arithmetic logic unit may be included in a single package called a microprocessor.
- A program is a set of instructions arranged in a sequential pattern to solve a particular problem.
- A microprocessor contains registers, arithmetic logic unit, timing and control circuitry, and decoding circuitry.
- Instructions for a microprocessor fall into nine categories:
 - Data movement
 - Arithmetic
 - Logic
 - Compare and test
 - Rotate and shift
 - Program control
 - Stack
 - Input/output
 - Miscellaneous

FIGURE 37-8

Microcontroller block diagram.



CHAPTER 37 SELF-TEST

1. Describe how a computer operates.
2. By what means does a computer that is interfaced to the real world manipulate data transmitted from an external device?
3. What is the difference between a microcomputer and a microprocessor?
4. What is the function of the microprocessor?
5. What is the difference between a microcontroller and a microprocessor?

SECTION 5 ACTIVITY—DIGITAL ELECTRONIC CIRCUITS

1. Design and build a circuit that will output your birthday or any other important date on a seven-segment display. Verify the circuit works properly using MultiSIM.
2. Design and build a circuit that can be programmed to count up or down to 199 using a seven-segment display. Verify the circuit works properly using MultiSIM.
3. Design and build an electronic circuit that can be programmed to output to a seven-segment display. Verify the circuit's operation using MultiSIM.
4. Design and build a circuit that can be programmed to control a small DC motor to run forward or in reverse. Use MultiSIM to verify that the circuit works.
5. Design and build a circuit that will allow a computer to sample data from its serial, parallel, or USB port.

This page intentionally left blank

SECTION 6

Practical Applications



CAREER PROFILE

Vercell Vance



TITLE
President and CEO

COMPANY
Alpha Data Corporation

BACKGROUND

Vercell Vance is founder, president, and CEO of Alpha Data Corporation, a technology company that specializes in electronics-related engineering services and information technology products. Vercell completed a Bachelor's degree in Computer Science and an MBA (with an emphasis in technology management) before founding his company. In the beginning, Alpha Data Corporation focused primarily on high-performance computing and electronic communication. Over time, Vercell expanded his company's markets into software engineering, scientific and engineering services, software and hardware support services, and electronic security-related products critical to the government's homeland defense system. Under Vercell's leadership, Alpha Data Corporation has been selected as the U.S. Small Business Administration's (SBA) Prime Contractor of the year as well as the SBA's Administrative Award of Excellence winner.

JOB REQUIREMENTS

Master's degree in Business Administration (MBA) with an emphasis on technology management and an electronic communication-related Bachelor's degree.

ON THE JOB

Vercell's days are like those of most CEOs of cutting-edge technology companies. Vercell provided leadership, motivation, organization, planning, administrative controls, decision making, problem solving, marketing, public relations, networking, customer relations, innovation and change management, and maintaining a high-performance environment for his personnel. Vercell makes time for community involvement, serving on the boards of various civic organizations, colleges, and business associations.

UPSIDE

It is satisfying to know that you are creating jobs that allow people to pursue their careers and support their families. It is also

satisfying to know that the company you created is doing its part to improve the quality of life in our community.

DOWNSIDE

Being president and CEO of a technology company is a demanding challenge that requires long hours and carries a heavy burden of responsibility. A large part of that burden is knowing that so many people depend on you for their livelihood. In order to ensure that your personnel have jobs in which they can build careers and advance in those careers, a CEO must ensure that his company is continually improving, innovating, and growing. In any business related to electronic communication, a company that is standing still is actually going backwards. Consequently, the president and CEO of a technology company must be an entrepreneur, leader, and manager—all at the same time.

OPPORTUNITIES

There are many opportunities for people with a strong background in both electronic communication and technology management to start their own companies. Electronic communication is now at the heart of every type of business, government, and military enterprise. There are no limits to the opportunities available to people who are willing to be entrepreneurial.

WORDS OF ADVICE

Never sell yourself short. You can be successful in the field of electronic communication if you are willing to work hard, work smart, and work long. Establish career goals for yourself, develop a plan for achieving them, and persevere through the rough spots until you succeed. Consider defining success not by the value of your financial portfolio, but instead by the number of hurdles you successfully conquer during the journey.

Printed Circuit Board Fabrication

OBJECTIVES

After completing this chapter, the student will be able to:

- Describe the fundamental process for making a printed circuit board.
- Design and lay out a printed circuit board from a schematic diagram.
- Discuss how to transfer a design to a copper-clad board using hand transfer, direct transfer, or screenprinting technique.
- Identify techniques to remove the excess copper from a copper-clad board on which a design is formed.
- Explain how to drill the appropriate holes in an etched printed circuit board.
- Identify the purpose and parts of a material safety data sheet (MSDS).

In the past, all printed circuit boards (PCBs) had traces on only one side. Today, printed circuit boards have traces on both sides and are referred to as double trace layers or double-sided boards. Complex boards may have four or more trace layers with each layer insulated from the other by board material. Special multilayer boards may have eight or more trace layers. This chapter focuses on how simple single and double-sided printed circuit boards are fabricated.

38-1 FUNDAMENTALS

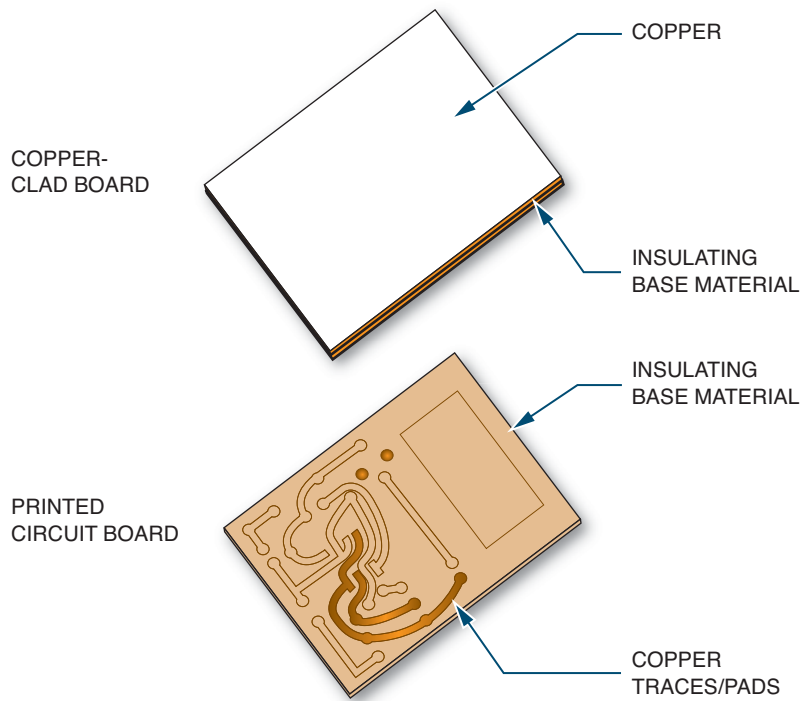
A **printed circuit board (PCB)** consists of an insulating base material that supports the copper **traces**, as shown in Figure 38-1. The insulating base material is typically epoxy fiberglass, but ceramic and Teflon are also used as base material in special cases.

Phenolic base material was used in the past for applications in which performance was not critical because it was inexpensive. The standard base thickness was typically 1/16" or 0.062" (Figure 38-2).

A majority of printed circuit boards made in the United States start with a solid copper foil that is bonded to the insulating base material, which is typically epoxy fiberglass (Figure 38-3). The

FIGURE 38-1

Copper clad board which is made into a printed circuit board.



thickness of the copper on a printed circuit board is designated in ounces. One ounce refers to the weight of copper spread over one square foot. One-ounce copper plating is approximately 0.003" thick. Two-ounce copper is 0.006" thick, and so on.

FIGURE 38-2

Standard board thickness.

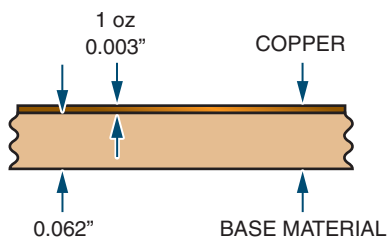


FIGURE 38-3

Example of epoxy fiberglass printed circuit board material.



FIGURE 38-4

Example of an etched printed circuit board.



The desired traces are printed onto the copper with a material called *resist*. The board is then placed in a chemical tray with a chemical for etching, referred to as an *etchant*, to remove the copper not covered by the resist, as shown in Figure 38-4. The etchants often used for etching small quantities of printed circuit boards are either ferric chloride or ammonium persulphate. A major concern with etchants is disposal according to current environmental standards.

Commercial printed circuit board fabricators generally use different chemicals that are less expensive, such as ammonium chloride. They heat the bath and add agents to improve performance.

After washing and cleaning the etched board, the result is a copper circuit pattern on an insulating base—a printed circuit board (Figure 38-5).

Prior to the arrival of **surface mount technology (SMT)**, there were two designated layers for through-hole printed circuit boards: the **component side** and the **solder side**. With the implementation of SMT, components are now placed on both sides of the printed circuit board, which are referred to as top and bottom. Both conventional through-hole

FIGURE 38-5

Printed circuit board that has been etched and resist removed.

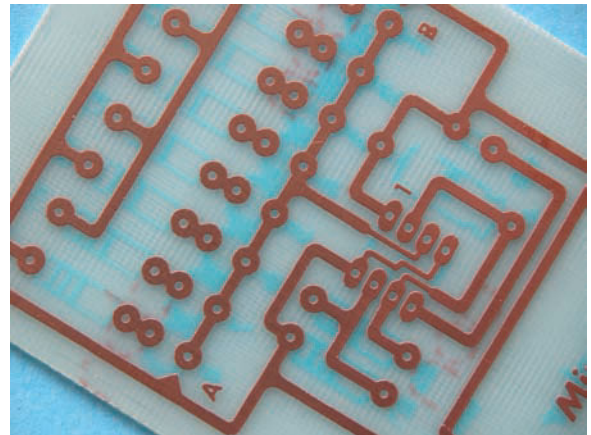
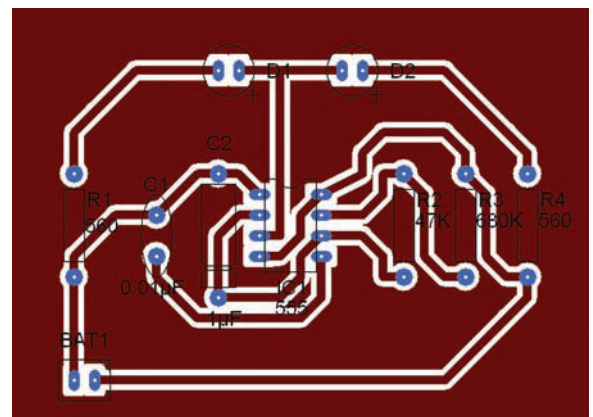


FIGURE 38-6

X-ray view of a printed circuit board layout from the component side.

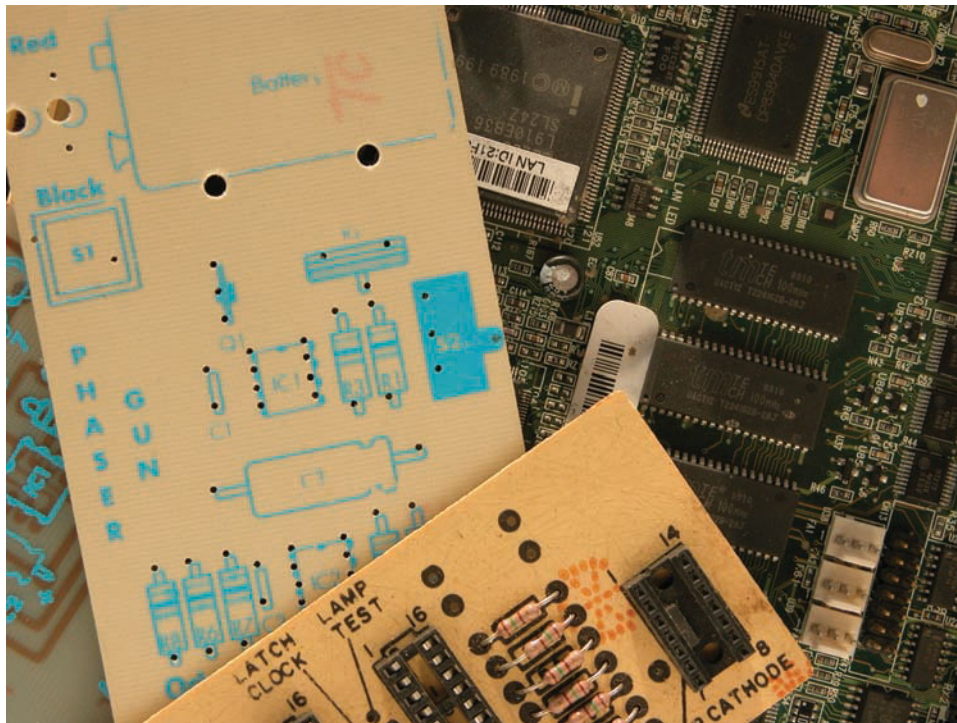


and SMT layouts are viewed from the component side, or top. This makes the bottom layer similar to an X-ray view through the insulating base material, which can be very confusing (Figure 38-6).

There are also two additional layers of a printed circuit board after it is etched. These additional layers are nonconductive and form the component layout layer and the solder mask layers. The component layout layer acts as a map when assembling and troubleshooting the printed

FIGURE 38-7

Examples of the component layer on printed circuit boards.



circuit board. This layout layer consists of text and graphic symbols that identify each component with its proper orientation. A good component layout layer can save a tremendous amount of time (Figure 38-7).

The solder mask controls or indicates where the **solder** will be placed on the printed circuit board pads during a process called wave soldering. This solder will only connect the components to the solder pads. When making only one or two boards with a simple design a solder mask may not be needed. Additionally, the solder mask adds corrosion protection to the printed circuit board traces.

In theory, with only through-hole passive components and discrete transistors, a single layer is all that is necessary (Figure 38-8). Most radio-frequency (RF) printed circuit boards have traces

on only one side, although a second layer is used as a **ground plane** to improve performance, as shown in Figure 38-9. Standard integrated circuits pin outs used with analog ICs—such as op-amps, timers, and so on—can get by with a single layer. This is because there is plenty of room for traces to pass between the leads of the passive components.

When digital logic or other designs that use high-pin-count chips are used, two trace layers are required. Digital IC chips with a large number of pins are impossible to connect to other chips with a different layout without crossing and shorting the traces. Therefore, a second layer is required. In theory, only two layers are ever necessary with high pin count components.

In practice, more than two layers are used for dense, highly populated boards or for perform-

FIGURE 38-8

Single-sided printed circuit board.

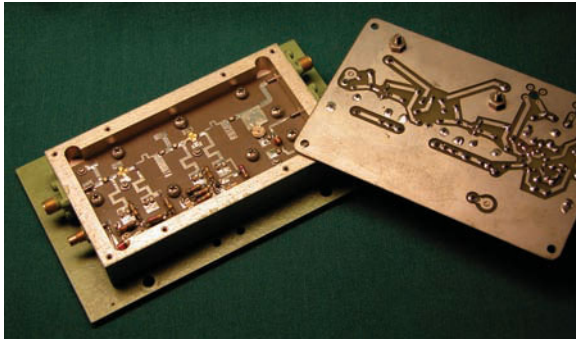
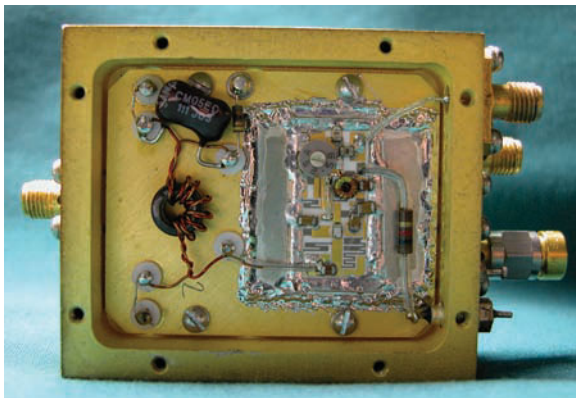


FIGURE 38-9

Ground plane on a printed circuit board.



ance considerations. Two layers are inadequate with densely populated printed circuit boards because the parts are so close together and the traces and holes take up too much space. There simply isn't room for all the traces, holes, and vias on two sides. *Vias* are connections between one layer and another (Figure 38-10). If the density could be reduced, the two-layer theory would work.

For high-speed or high-precision designs, more than two layers are used to improve performance. With four trace layers, the two middle ones are usually power and ground. This evens

out the flow of power and reduces voltage fluctuations at different points on the printed circuit board. The ground plane layer provides controlled impedance for high-speed signals. The close proximity of the ground and power planes also acts as a capacitor to reduce noise. One problem with multilayer printed circuit boards is reliable connections between the layers. It is sometimes difficult to detect which layer is defective.

Two sides can be etched at the same time; therefore, the cost of a **double-sided board** is only slightly higher than that of a **single-sided board**. **Multilayer boards** are built up by laminating layers together. A four-layer board will cost about twice as much as a double-sided printed circuit board. The printed circuit board is often the most expensive part of a design.

38-1 QUESTIONS

1. What are the materials that make up a printed circuit board?
2. How is the copper on a printed circuit board designated?
3. What is the function of resist?
4. Describe the process for making a printed circuit board.
5. What is the significance of SMT?

38-2 SCHEMATIC DIAGRAM

The key to an effective printed circuit board design is a **schematic diagram** that becomes the basic reference for a circuit and gives the necessary specifications needed to design a printed circuit board. The diagram should exhibit good signal flow and complete reference data.

The best way to preview a schematic diagram is to lay out or view a block diagram of the circuit. The block diagram will represent how the component

FIGURE 38–10

V/As connect the top to the bottom trace of a printed circuit board.

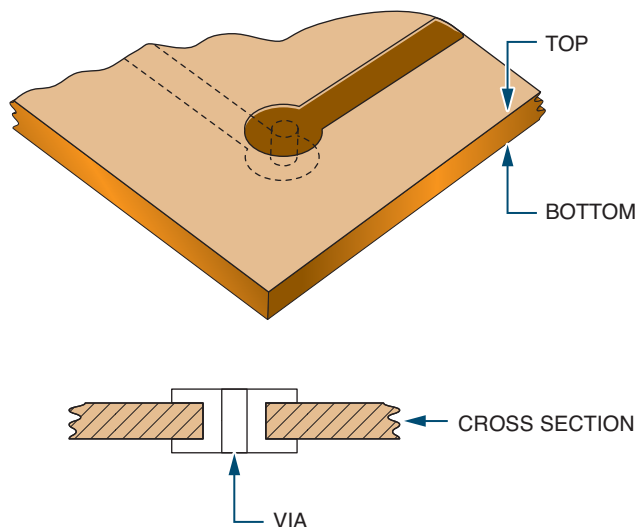


FIGURE 38–11

Block diagram.



blocks are connected. As an example, one block may represent a stage of signal amplification with one signal entering and one signal leaving and proceeding to the next block (Figure 38–11).

Analog circuits use discrete components such as resistors, capacitors, and semiconductor devices. Analog schematics present a different appearance than digital schematics.

Discrete analog components may require close physical proximity to the printed circuit board surface to maintain signal paths and to prevent coupling or delays between stages. Tight component grouping is important to show in the schematic diagram so the printed circuit board layout can follow it precisely.

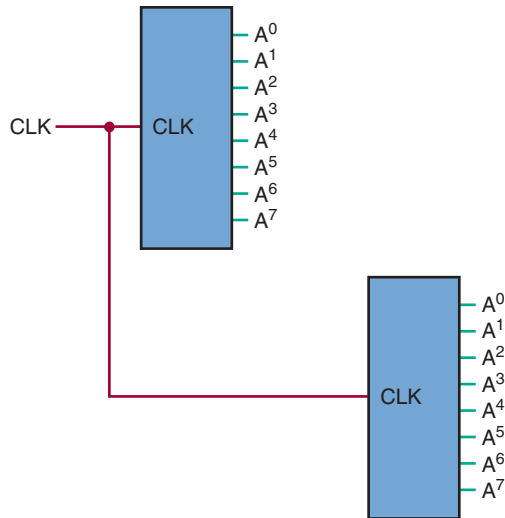
Digital schematic diagrams appear quite different from analog schematic diagrams due to differing interconnection patterns. Digital circuits tend to have many common signals that occur throughout the schematic. This results in many long signal lines that transverse the length and width of the drawing. To avoid confusion it is better to label the common signals rather than drawing every connection as a line, as shown in Figure 38–12.

A schematic diagram should show the entire circuit in as few drawings as possible and should use the following technique:

1. Group subcircuits components together in the drawing.

FIGURE 38-12

Label common signals in digital circuits.



2. Signal flow should proceed from left to right with input on the left and output on the right (Figure 38-13).
3. Voltage potentials are drawn with the highest voltage at the top of the diagram and

the lowest at the bottom, as shown in Figure 38-13.

4. Signal lines should cross each other as little as possible. On digital schematic diagrams label the connections with the appropriate signal abbreviation rather than drawing a complete maze of lines (Figure 38-14).
5. Label components starting on the left or input side of the schematic diagram and move down and then back to the top, repeating this process across the schematic diagram (Figure 38-15).
6. Critical leads should be short or isolated from other signals.
7. All external connectors and components should be clearly indicated.
8. All integrated circuit pins should be labeled, including the power supply inputs.
9. Any unused integrated circuit logic gates or extra subcircuits inputs should be tied to the appropriate power supply level to provide stability in the circuit.
10. Extra components, such as bypass capacitors, that are installed during the printed circuit board construction process should be added to the final schematic.

FIGURE 38-13

Signal flows from left to right, voltage potential has highest potential at top.

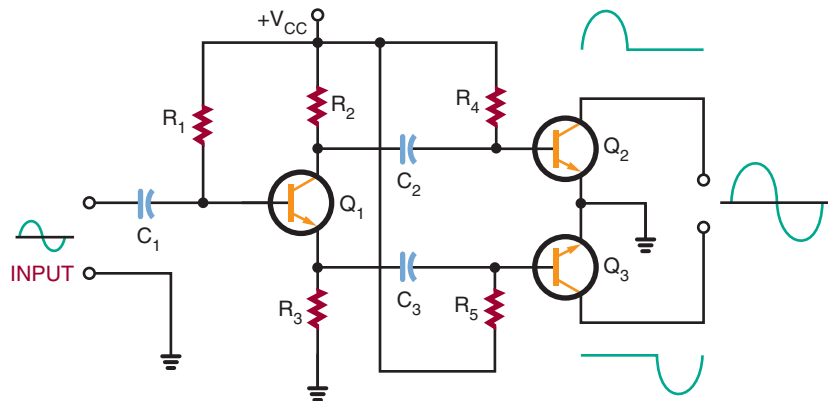


FIGURE 38–14

Use signal abbreviations rather than draw a maze of lines.

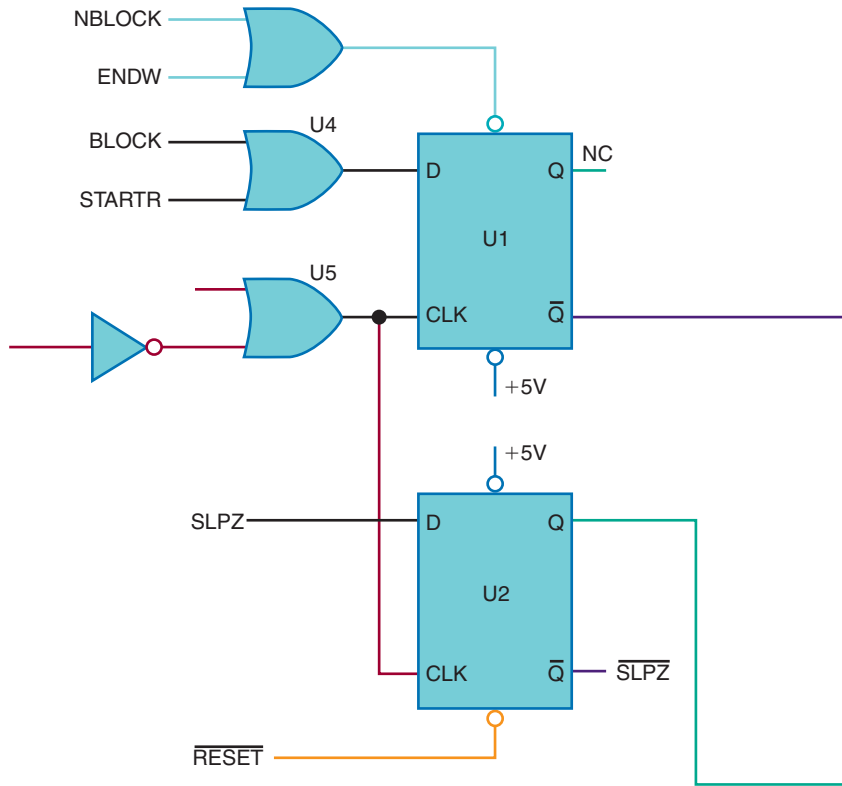


FIGURE 38–15

Label component starting at the left side and move top to bottom repeating across the schematic.

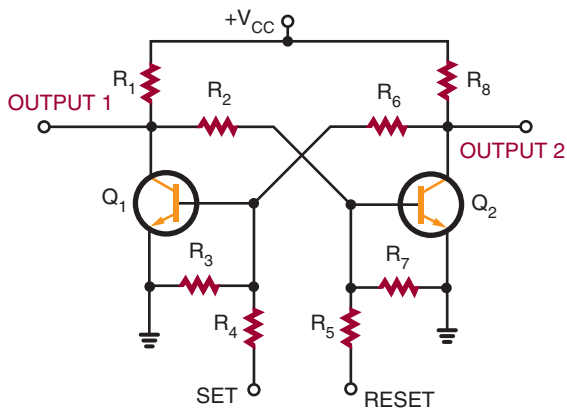
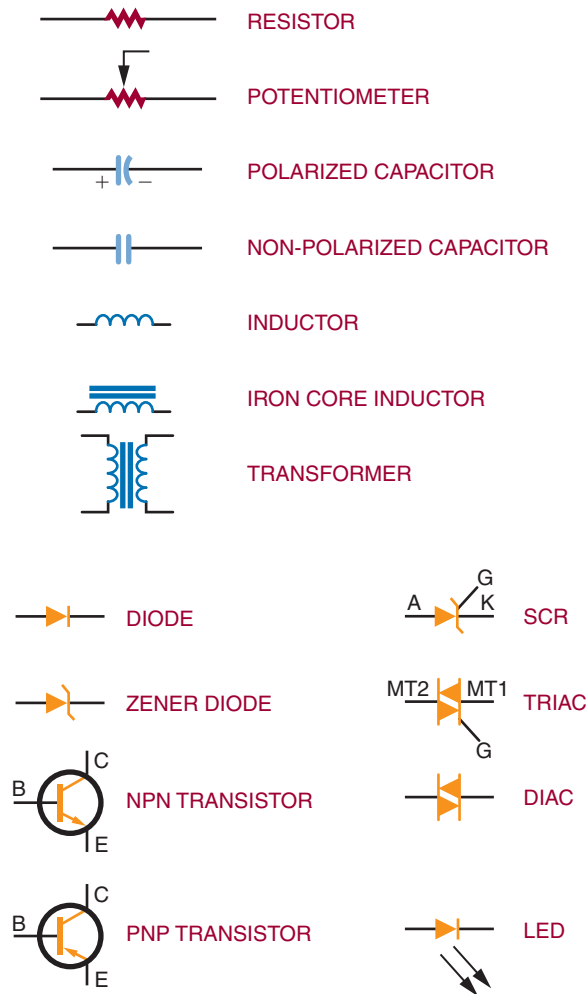


Figure 38–16 shows the schematic symbol for common components used in the electronics field. Keep in mind the following points while reviewing the symbols:

1. Components that are variable include an arrow as part of their symbol. For example, a potentiometer is a variable resistor.
2. Arrows also indicate the emitting or receiving of various forms of energy. Arrows pointing away from a symbol indicate it is giving off energy, such as a light-emitting diode (LED). If the arrow is pointing toward a symbol it indicates it is receiving energy, such as a photocell.

FIGURE 38–16

Schematic symbols for common electronic components.



- A component's lead may be identified with letter symbols. For example, SCR leads are identified A (anode), K (cathode) and G (gate). Transistor leads are identified as C (collector), E (emitter), and B (base).

Figure 38–17 shows two schematic symbols for ground. The most commonly used symbol is shown in Figure 38–17A. It represents chassis or

earth ground, may be used multiple times in the same schematic diagram, and represents a common return point for a circuit. The ground symbol shown in Figure 38–17B represents chassis ground only. If the schematic drawing uses this symbol it is connected to the ground prong of an AC line cord and the chassis will be at earth ground potential.

FIGURE 38-16

Schematic symbols for common electronic components. (Continued)

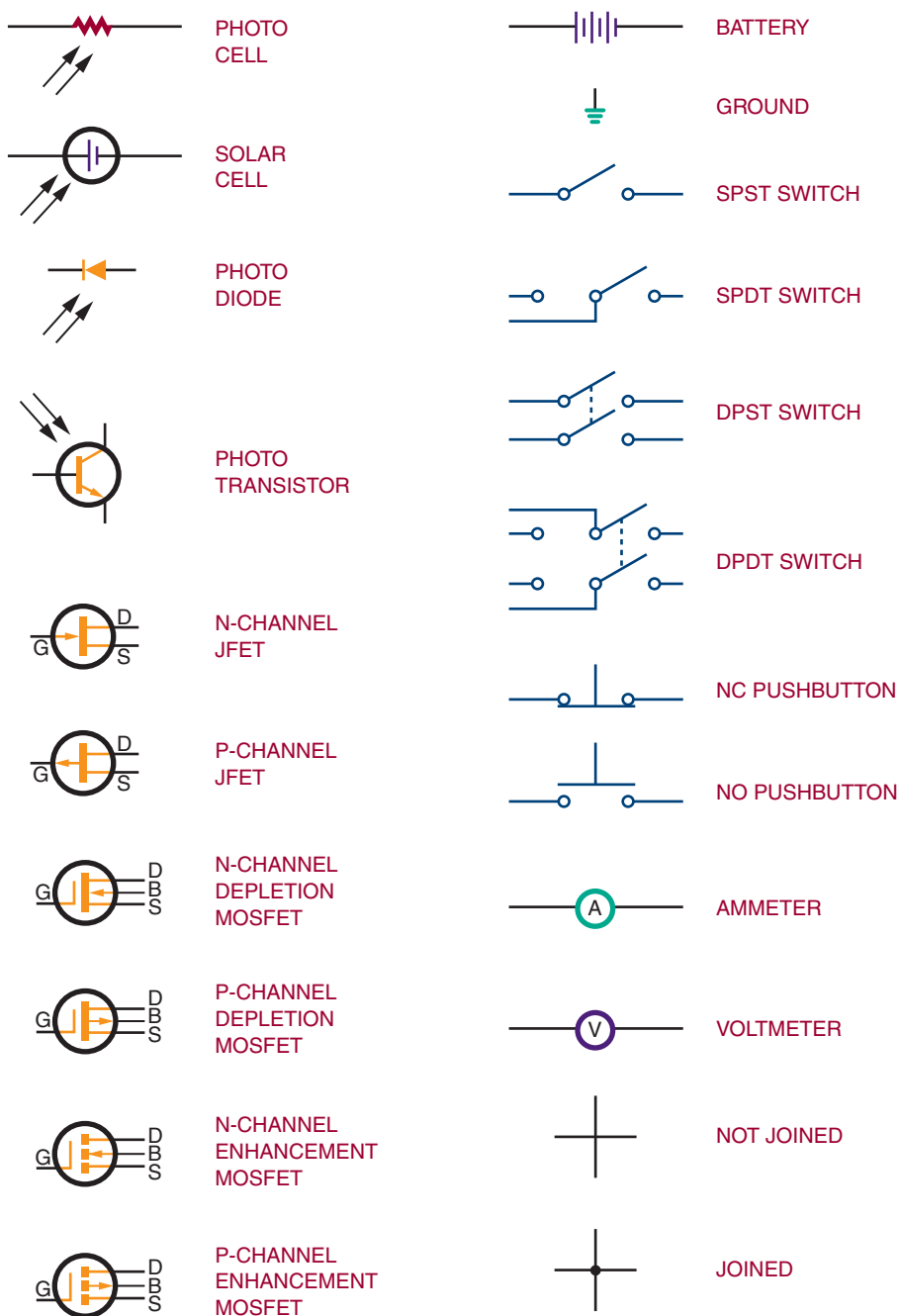


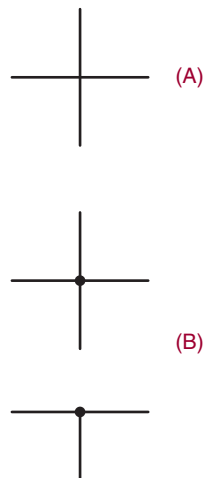
FIGURE 38-17

Ground symbols.



FIGURE 38-18

Schematic drawing lines.



Schematic drawing lines represent wires or component leads. Letting lines cross on a diagram does not mean a connection occurs (Figure 38-18A). If a connection is intended, as shown in Figure 38-18B, a dot is placed at the junction. A connection dot is also used when three or more lines come together.

Common drafting tools are used in the generation of schematic diagrams. Using schematic symbol templates can speed up the process. Computer programs can also speed up the generation of a schematic diagram. In addition to **computer-**

aided design (CAD) programs, specialty programs are also available. Specialty programs include computer programs such as Electronic Workbench MultiSIM and New Wave Livewire. These programs not only allow the schematic diagram to be drawn but also simulate current through the circuit and allow the user to troubleshoot on the computer using **virtual test equipment**. Additionally, the computer program Livewire shows animated current flow throughout the circuit represented by the schematic diagram.

38-2 QUESTIONS

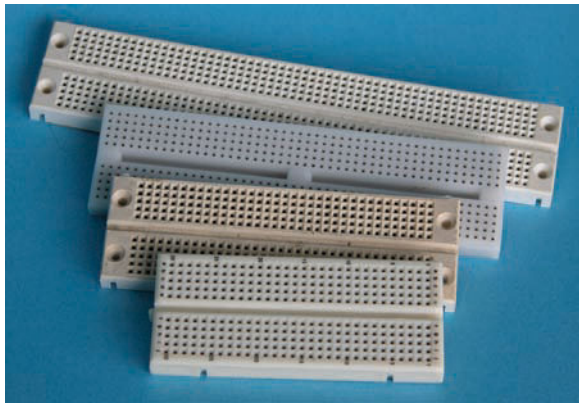
1. What is the purpose of a schematic diagram?
2. What function does a block diagram serve?
3. Why is tight component grouping shown on a schematic diagram?
4. What techniques are used when drawing a schematic diagram?
5. What can be used to speed up the diagram-drawing process?

38-3 BREADBOARDING

Breadboarding is essential to proving a circuit design works. The most popular technique involves the use of **solderless breadboards** (Figure 38-19). Solderless breadboards were developed to allow circuits to be assembled and altered quickly without soldering. A printed circuit board is not easy to modify once the circuits are assembled. Printed circuit boards only allow minor alterations following final assembly, such as changing resistor or capacitor values or replacing integrated circuits with the same type of devices.

Computer programs such as CircuitMaker, Electronics Workbench's MultiSIM and New Wave Livewire, ORCAD's Pspice, and Spectrum

FIGURE 38–19
Solderless breadboards.



Software's Micro-Cap 7 allow **virtual breadboarding**, or testing of a circuit and troubleshooting using virtual test equipment. Livewire also shows the current flow in a circuit to aid in understanding how a circuit performs. These programs are the wave of the future.

38–3 QUESTIONS

1. What function does breadboarding serve?
2. Why were solderless breadboards developed?
3. Why should a circuit be breadboarded?
4. What are some computer programs that allow virtual breadboarding?
5. Why is a program such as Livewire important to the study of electronics?

38–4 LAYING OUT PRINTED CIRCUIT BOARDS

Once a good schematic diagram is confirmed through breadboarding, either physical or virtual, the printed circuit board can be laid out. The

necessary electronic components should be collected for sizing the design layout. Leave the components from the breadboard together and use them only as a last resort. A working circuit on the breadboard can be used for troubleshooting in the event there is a problem with the printed circuit board design.

Once the decision to design a printed circuit board has been made, a number of questions must be addressed before the printed circuit board is laid out:

1. What is the power source? Will it be part of the board design or external to it?
2. What oddly shaped or sized devices will be mounted? Devices such as relays, switches, and large capacitors need to be identified.
3. How are the discrete components attached? They need to be identified along with sockets, pins, connectors, and mounting devices.
4. What are the testing and troubleshooting considerations? They must be taken into account to make the board accessible for test measurements of all signals.
5. Will the board be mounted in an enclosure? How much space it will use and how it will be attached must be taken into consideration.

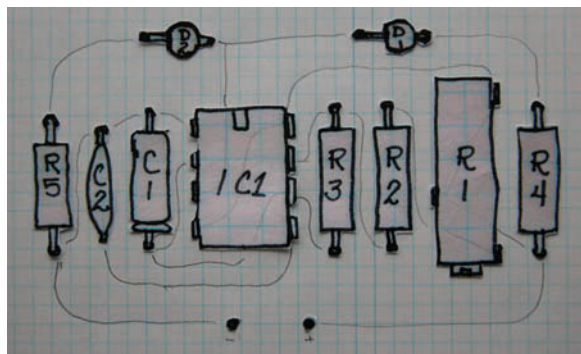
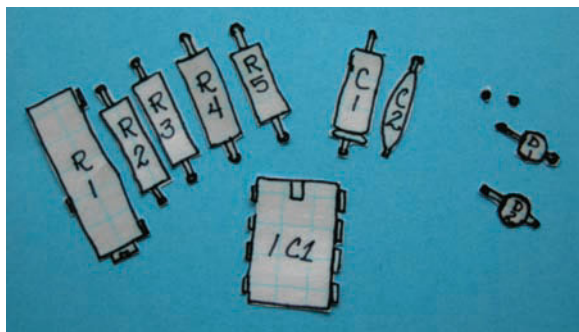
Once the questions have been answered, identify which components will be mounted on the printed circuit board and which ones will be off the board.

One approach to a printed circuit board design layout is to use **paper dolls** of each component that is to be mounted on the printed circuit board (Figure 38–20). Each paper doll is the exact size of the base of the component being used and permits correct component placement.

Using the paper dolls, lay out the printed circuit board in such a way that the paper dolls duplicate the schematic diagram. Exact component and lead placement are not critical at this stage. Next, consider the trace placements for proper electrical connections. During the layout process,

FIGURE 38–20

Using paper dolls for laying out a printed circuit board design.



the printed circuit board will be viewed from the component side or top. Three issues address the best component placement:

1. Wasted board space—Keep components in a horizontal or vertical plane, parallel to the board edge, to achieve a tighter layout. Avoid diagonal placements.
2. Insertion of polarized components—Try to group polarized components facing the same direction to aid assembly.
3. Ease of troubleshooting—Components should be easy to find; try to keep input on the left side of the board, output on the right, and power from top to bottom of the board.

With the exception of discrete logic gates and multiple op-amp packages, arrange the IC pins in

physical order, as viewed from the top. Start with the IC that has the most pins and then place the other parts that follow the simple schematic. The goal is to lay out a printed circuit board with no crossed traces that resembles the physical relationship of the schematic diagram, which becomes useful in troubleshooting.

Transfer the paper doll components to a 0.100" grid graph paper (ten lines per inch). Component orientation should be horizontal or vertical to the edge of the board. Identify the top and bottom layers with text component side and solder side. The solder side is viewed from the top like an X-ray view, as shown in Figure 38–21. Traces are then laid out left to right or top to bottom, with exceptions permitted. Traces may be routed between component leads but not between the leads of semiconductor devices. At this stage it may be necessary to reposition parts on the layout to avoid crossing traces. Once the paper doll components are placed and the traces are laid out, the decision to make a single-side or double-sided printed circuit board can be identified. If no traces cross, a single-sided printed circuit board is optimal; otherwise, a double-sided printed circuit board will be used.

Another choice for crossed traces is to make a single-side board with **jumpers**, as shown in Figure 38–22, but keep the jumpers to a minimum. Rearranging artwork can often eliminate the need for a jumper wire. Some guidelines for do's and don'ts for trace layouts are shown in Figure 38–23.

Rules are made to be broken, even when designing printed circuit boards. When a printed circuit board is designed that has a connection on one edge, the input and output connections are on the same edge of the board. When this occurs, separate them on opposite ends of the connection. If this is not possible, separate them by putting other traces in the space between them.

Pads are placed on the printed circuit board when a connection is to be made. A pad is used to connect a lead from a component or connect a

FIGURE 38–21

Solder side as viewed from the top.

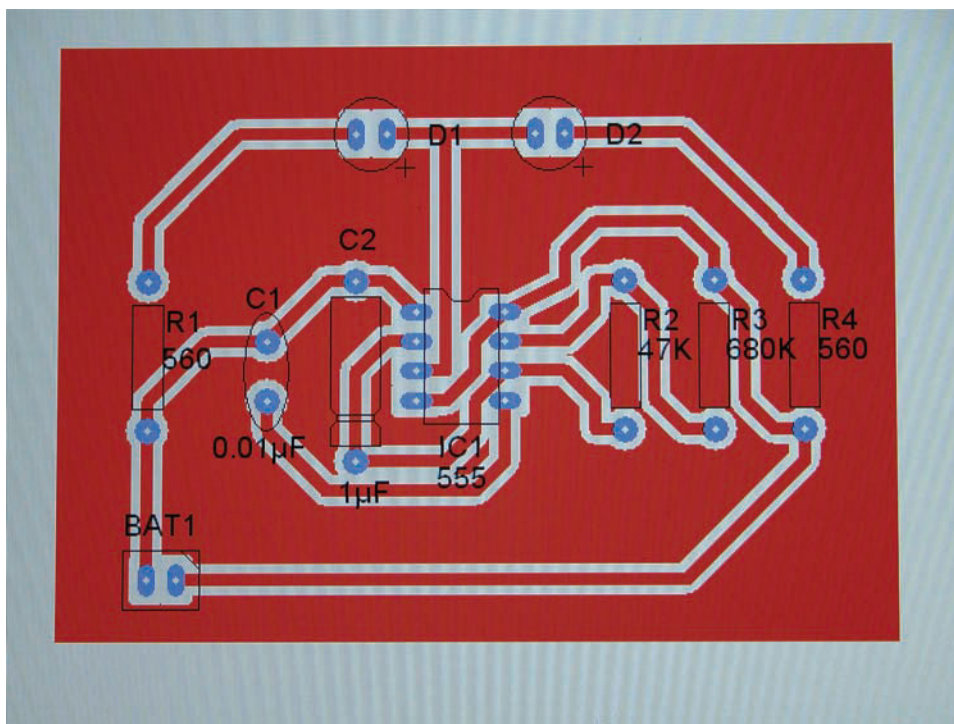
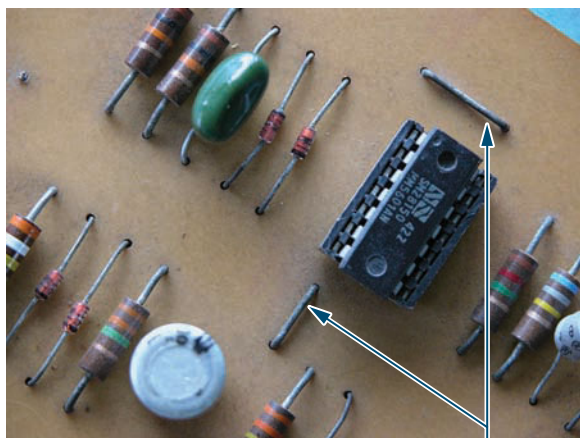


FIGURE 38–22

Single sided printed circuit board using jumpers.



JUMPER

wire from an off-board component. Generally, each lead has its own mounting pad. Two leads connected to the same point will each have their own mounting pad. Multiple pads are permitted (Figure 38–24). Each component should have enough mounting room. It is difficult to modify the board or component for errors after a printed circuit board is made.

Double-sided printed circuit boards should always have some identification on the top and bottom layer to aid in proper orientation. In the past, optical targets or registration marks were used to aid in differentiation between the top and bottom traces. Presently, this step is omitted by identifying pin 1 of an IC with a square pad.

FIGURE 38–23

Guidelines for trace layouts.

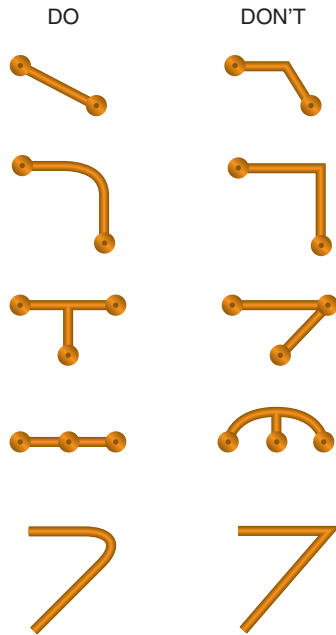
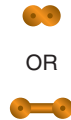


FIGURE 38–24

Two leads connecting to the same point will have a pad for each lead.



Printed circuit boards are easier to manufacture if the traces are wide and far apart—this also makes the board more reliable and provides better performance. Most printed circuit board manufacturers will work with 0.007" traces and spaces (Figure 38–25).

Traces that are too thin are fragile and have higher resistance than thick traces and handle less current. Estimating how much current a trace can handle is important. Figure 38–26

FIGURE 38–25

0.007 "trace versus 0.020" trace.



shows a table comparing trace width and current capacity for a 1-ounce-per-square-foot copper foil. These values are reasonably linear for different trace cross-section areas.

Traces that are placed close together may short out and can electrically short to each other. The traces can also act as antennas and capacitors. High-speed digital lines next to high-impedance analog lines will cause problems. Long traces have the same problems as long wires. They pick up noise and have noticeable impedance. Even though a digital design only runs at 1 MHz, the changing state will cause transients in the GHz range.

Guidelines on laying out traces are shown in Figure 38–27. Try to limit using acute angles of less than 90° in traces. They leave a point that causes problems by acting like a one-turn inductor. Additionally, the point will not be well supported and will easily lift—it's not good to have traces peeling off a printed circuit board.

Using two 45° angles instead of one 90° angle will save space. This is especially true when there are a lot of traces running parallel to each other. The more space saved, the smaller and less expensive the printed circuit board will be. Printed circuit boards are purchased by the square inch.

Proper grounding is critical. A ground and power plane are ideal, but often it's simply too expensive as it doubles the cost of a printed circuit board.

In laying out a printed circuit board it is best to start with a wide ring of 0.100" to 0.250" around the printed circuit board to form a ground. This provides large ground areas around the printed

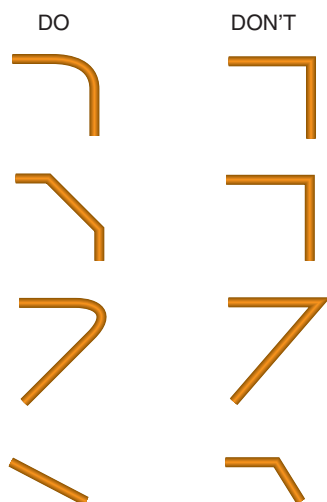
FIGURE 38–26

Printed circuit board trace information for 1-ounce copper clad board (based on a trace length of 10 inches).

TRACE WIDTH IN INCHES	TRACE WIDTH IN MILLIMETERS	RESISTANCE /MM IN $\mu\Omega$	1 OZ COPPER 0.00135" THICK		CURRENT IN AMPERES AT 20°C
			cm ²	AWG	
0.02	0.508	989.7	0.000174	35	3.00
0.04	1.016	494.9	0.000348	32	5.00
0.06	1.524	329.9	0.000523	30	6.50
0.08	2.032	247.4	0.000697	29	7.00
0.10	2.540	197.9	0.000871	28	8.00
0.12	3.048	165.0	0.001045	27	9.25
0.14	3.556	141.4	0.001219	26	10.00
0.16	4.064	123.7	0.001394	26	11.00
0.18	4.572	110.0	0.001568	25	11.75
0.20	5.080	99.0	0.001742	25	12.50

FIGURE 38–27

Trace layout Do's and Don't's.



circuit board mounting holes, which are typically located near the edge of the printed circuit board. This setup allows a star washer and a metal screw to the chassis make a good chassis-ground connection. It also means that ground traces only have to go to any board edge, simplifying the layout. If there is any concern regarding ground loops with more than one ground current flowing in one conductor, it can be solved by cutting the loop.

In this matter the current flows in the trace can be controlled. If a design is fairly simple, spend the extra time to make it a single-sided printed circuit board and use the second side as a **ground plane**. There are always more connections to ground than to any other circuit node.

When the layout is finished, increase the width of the power and ground traces as much as

possible. In large areas without traces, fill them with solid copper connected to power or ground. More copper often helps and very rarely hurts printed circuit board performance and reduces etching time.

Proper placement of traces is something that is learned through practice. The only way to do it is to actually hand-route printed circuit boards. A common and effective technique is to run horizontal traces on one layer and vertical traces on the other layer. Obviously, this doesn't work for single-layer boards. This tends to create boards with a lot of vias. A via is a plated through-hole used to pass a conductor from one side of the printed circuit board to the other.

Basic rules for laying out a printed circuit board include:

- Avoid running parallel traces closer than necessary.
- Segregate analog and digital areas.
- Put ground traces next to sensitive analog lines to act as shields. Do the same for high-speed clock lines to reduce electromagnetic interference (EMI) and crosstalk.
- Pay close attention to parts placement. It's amazing how this can simplify routing.

It is useful to use a color-coded system to simplify the presentation of a double-sided printed circuit board during the design process. This process is standard with computer-generated designs. It can also be done with colored pencils. A typical color-code system is as follows:

- Black—board outline, holes, pads, and hardware.
- Green—component electrical symbols and outlines.
- Red—connecting traces on the component side.
- Blue—connecting traces on the trace side.
- Yellow—through holes.

Surface mount technology (SMT) has added more facets to printed circuit board layout. The parts are very small and the lead pitch or spacing between the centers of adjacent leads can be very small. It is not possible to run any traces between the leads. This makes routing more difficult and increases the number of vias.

It's virtually impossible to use a single-side layout with high-pin-count SMT ICs. The pad sizes and shapes are different for different parts. You will need to refer to the manufacturer's specifications. With SMT designs, testing and repair need more consideration because it's hard to probe tiny, closely spaced pins. Boards should be laid out to make servicing easy.

Autorouters programs are designed to use the computer to lay out a printed circuit board. Autorouters should not be relied on unless they are "smart." Typical low-cost routers only connect points together. They don't consider the length of the trace, which traces are analog and which are digital, which lines are sensitive, which are ground loops, and so on. Subtle points can make a significant difference in how a printed circuit board performs. It's easier to lay out a printed circuit board manually than to root out elusive errors made by a program.

Getting a printed circuit board made commercially requires a design to be sent by the Internet to a service. It will require the following files in **Gerber** format for a standard double-sided printed circuit board:

1. Top trace layout
2. Bottom trace layout
3. Silkscreen (if used)
4. Solder mask (if used)
5. Aperture file
6. Drill file

The Gerber format is a standard printed circuit board format supported virtually all layout software. The Gerber files define the trace placement, but they don't specify the physical sizes.

The **aperture file** specifies the physical sizes with a short list of “flash codes” Additionally, the Gerber files don’t specify the actual size of the holes to be drilled in the printed circuit board. The **drill file** informs the manufacturer of where the holes are and what size they are supposed to be. Drilling and etching are two separate procedures. When these files are sent, they include a short “read me” file that relates the file names to the physical parts of the printed circuit board to save time and lessen confusion.

Proper printed circuit board layout requires common sense, patience, and attention to detail.

38-4 QUESTIONS

1. What is necessary to collect prior to laying out a printed circuit board, and why?
2. What decision must be made prior to laying out a printed circuit board?
3. What approach can be used in laying out a printed circuit board?
4. What issues must be addressed in placing components on a printed circuit board layout?
5. How can cross traces be addressed on a single-sided board?
6. On double-sided board layouts, how are the sides identified?
7. Why are thin traces undesirable on a printed circuit board layout?
8. What guidelines are essential in laying out a printed circuit board?
9. What purpose do ground and power planes serve?
10. How are traces run on a double-sided board?
11. What consideration should be regarded when laying out a printed circuit board?

38-5 TRANSFERRING DESIGNS

There are several techniques used to transfer the artwork to the copper-clad board. The simplest technique is to **hand-draw** the design on the board with a resist pen or any other permanent marker with a very fine tip.

Take the original artwork and transfer it to the back of the graph paper. Place the component side of the artwork to the surface of a light table or hold the paper to a window with light on the opposite side. Start by placing Xs where each pad is located and then connect the pads with the trace lines. On the side just drawn, write “BOTTOM.”

Wrap the artwork around a piece of copper-clad board that has been properly cut to size. Clean the board with steel wool or with powder cleanser and water prior to wrapping the artwork around the board. The copper side of the board should be toward the artwork with the side identified as bottom facing outward.

Using a scribe, locate the center of each pad where an X was placed on the bottom side. Prior to removing the artwork, run a finger over each pad to ensure it was marked with the scribe. Remove the artwork, being careful not to get fingerprints on the copper.

With a resist pen or other fine-tip permanent marker, such as a black Sharpie, draw the pads at each of the scribe marks. Using the bottom-view artwork, connect the pads with traces. Go over each of the traces and pads several times to build up a thick layer of resist.

Another technique for creating a resist involves using the computer to make the artwork with a CAD or drawing program. Draw the design from the component side and then reverse it to form the trace or bottom side. Print out a positive image 1:1 on transparency or special film that can then be transferred to a clean, properly sized copper-clad board with an iron and pressure.

A second technique involves printing out two positive copies of the artwork 1:1 on transparency film. Align the two pieces of film and tape them together. They form a positive film transparency. If a higher density is needed from the film, align and tape additional pieces of film. Sensitize a clean copper-clad board with positive resist according to manufacturer instructions. Using a contact print frame, sandwich the film and sensitized board together with the bottom side outward. Expose the sandwiched board and film to an ultraviolet light source or sunlight. Develop the board in the appropriate developer; rinse and dry the board. This technique forms a very good quality resist.

A third technique involves using the positive film transparency developed in the previous discussion to create a screen for screenprinting the printed circuit board. A good graphic arts book will cover the making of a screen and the screenprinting process in detail. Use resist inks or oil base inks when screenprinting the layout on the boards.

38-5 QUESTIONS

1. List the techniques for transferring a design to a printed circuit board.
2. Why is it essential to label the top and bottom of a printed circuit board?
3. What can serve as a resist with hand-drawn printed circuit boards?
4. How can the density be increased when using transparency film?
5. What purpose does screenprinting serve with printed circuit board fabrication?

38-6 ETCHING PRINTED CIRCUIT BOARDS

There are two major techniques to remove copper from a copper-clad board to form a printed circuit board. The first technique involves using a

mild acid such as **ferric chloride** or **ammonia persulphate**. The other technique uses a CAD-type program and a **CNC (computer numerical control) machine** to remove the copper and is referred to as a non-chemical process. Environmental and safety issues are favoring the use of nonchemical copper removal techniques.

Using either ferric chloride or ammonia persulphate acid the copper can be removed by the tray method or with a spray etcher.

CAUTION: WHEN ETCHING, ALWAYS WEAR SAFETY GLASSES, RUBBER GLOVES, AND AN APRON.

To use the tray method, the copper-clad board with applied resist is etched in a glass tray by dropping the board onto the surface of the acid. The copper side of the board should face toward the acid. Float it on the acid for approximately fifteen to twenty minutes. The acid laden with copper sinks to the bottom and fresh acid replaces it. In this fashion no agitation is required.

A different technique uses a one-inch square of sponge to dab the acid on the printed circuit board. The acid is absorbed in the sponge by pouring a small amount on it. The sponge is dabbed continuously on the copper on the board until the copper is removed. Boards with thinner copper will etch faster.

CAUTION: ALWAYS WEAR SAFETY GLASSES, RUBBER GLOVES, AND AN APRON WHEN USING THIS TECHNIQUE.

Another method to remove the excess copper from the board is to use a commercial or shop-built spray etcher (Figure 38-28). These etchers can etch the board in approximately two minutes. A spray etcher is the best way to etch double-sided boards.

FIGURE 38–28

Examples of commercial spray etchers.

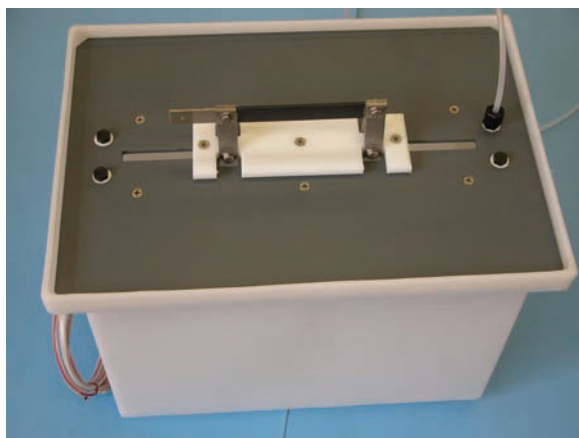
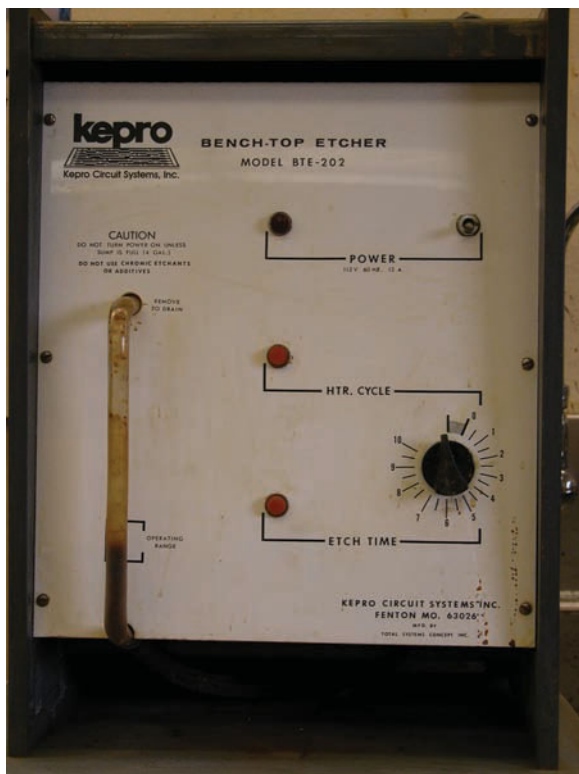
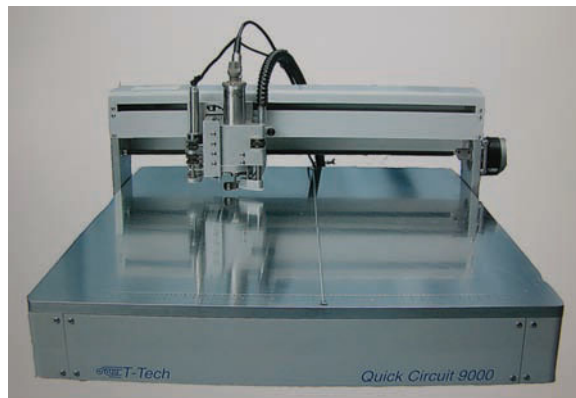


FIGURE 38–29

CNC used for printed circuit board fabrication (Courtesy of T-tech).



Computer programs such as New Wave's PCB Wizard provide the appropriate codes to drive a CNC machine to remove the copper to form a printed circuit board. Figure 38–29 shows a CNC machine.

38–6 QUESTIONS

1. What are two ways to remove the copper to form a printed circuit board?
2. What acids can be used safely for removing copper to make a printed circuit board?
3. What safety precautions should be used when working with acid?
4. What are three techniques for removing copper using acid?
5. How do computer programs drive a CNC machine?

38-7 PREPARING THE ETCHED PRINTED CIRCUIT BOARD

After the printed circuit board has been etched the resist needs to be removed. Remove the printed circuit board from the acid, rinse it thoroughly in running water, and dry it. The resist can be removed by soaking the board in a solvent, scrubbing it with powder cleanser, or using steel wool to rub it off. After the resist is removed from the printed circuit board, be sure to avoid getting fingerprints on the board.

The next step is optional in fabricating a printed circuit board. The printed circuit board can be tin-plated to stop oxidation of the copper using a tin-plating solution, as shown in Figure 38-30. The printed circuit board is immersed in the solution for a set amount of time identified by the manufacturer.

FIGURE 38-30
Example of tin-plating.



Any defects resulting from the etching process should be taken care of at this time. Types of defects include traces that are **bridged** or shorted together or traces that are open (Figure 38-31). Traces that are shorted together can be separated using a knife. Traces that are open need to be bridged with wire and solder.

Use a high-speed drill for drilling all holes (Figure 38-32). Use a backer board under the printed circuit board to avoid breakout of the backside. A number 59 drill bit is used for all holes. Holes that need be drilled larger are then drilled. Burrs that form around the holes can be removed by hand using a larger drill bit and a twisting motion (Figure 38-33).

If the printed circuit boards are going to be soldered using a wave soldering station, a solder mask is applied to the bottom of the board. The solder mask allows the solder to flow on only the points that require solder. The solder mask can be screenprinted on the printed circuit board at this time.

FIGURE 38-31
Example of traces shorted together.

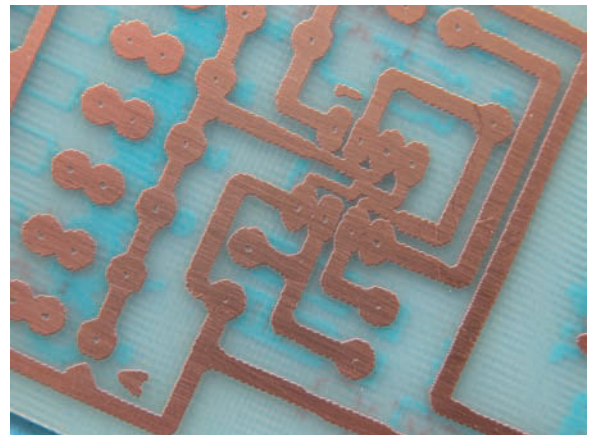


FIGURE 38-32

High speed drill for drilling holes in a printed circuit board.

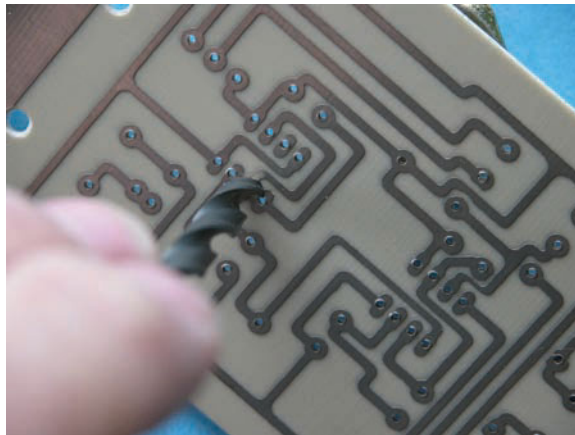


38-7 QUESTIONS

1. How can the resist be removed from a printed circuit board?
2. What has to be avoided once the resist is removed from the printed circuit board?
3. What is the purpose of tin-plating?
4. What types of defects can occur when fabricating a printed circuit board?
5. How are the holes made in a printed circuit board?
6. What is the function of the solder mask?

FIGURE 38-33

Removing burrs from drilled holes.



38-8 MATERIAL SAFETY DATA SHEET (MSDS)

OSHA (the Occupational Safety and Health Administration) requires that a **material safety data sheet (MSDS)** be supplied when a chemical or hazardous substance is purchased. The law requires that copies of MSDSs be maintained and available on request by the person(s) using this material.

When unpacking a shipment of chemicals look for the MSDS in the box. File the MSDS in a folder in the location where the chemical is being used.

MSDSs should be kept on file for two reasons:

1. To help protect personnel from injury and exposure hazards.
2. It is required by law.

Read each MSDS before using hazardous material. Everyone who uses the chemical product must understand its dangers and the precautions to be taken while using it.

Figure 38-34 provides a brief description of the sections of an MSDS. Figure 38-35 shows an MSDS for ferric chloride.

FIGURE 38–34

Sections of a Material Safety and Data Sheet.

Parts of A Material Safety and Data Sheet

Top Portion
<ul style="list-style-type: none">• Name of Manufacturer• Manufacturer's Address• Emergency Phone Number• Trade name of Product(s) with stock number(s)
Section 1 Hazardous Materials
<ul style="list-style-type: none">• Exposure recommendations for individual components.<ul style="list-style-type: none">◦ <i>Components are listed if present at or above 1% in the mixture and present a physical or health hazard.</i>◦ <i>Components identified as carcinogens by NTP, IARC, and OSHA, are listed if present at or above 0.1% in the mixture.</i>• All exposure limits are those that OSHA and ACGIH (American Conference of Governmental Industrial Hygienists) concur unless specifically listed as an OSHA Permissible Exposure Limit (PEL) and/or an ACGIH Threshold Limit Value (TLV).
Section 2 Physical And Chemical Properties
<ul style="list-style-type: none">• Boiling Point - Of product, if known. If unknown, the lowest value of the component is listed for mixtures.• Vapor Pressure - Of product, if known. If unknown, the lowest value of the component is listed for mixtures.• Vapor Density - Compared to Air = 1. If specific vapor density of product is not known, the value is expressed as lighter or heavier than air.• Evaporation Rate - Indicated as faster or slower than Ethyl Ether or Butyl Acetate.• Specific Gravity - Compared to water = 1. If specific gravity of product is not known, the value is expressed as less than or greater than water.• Appearance and Odor - Describes the physical appearance, color and smell of the product.
Section 3 Fire And Explosion Hazard Data
<ul style="list-style-type: none">• Flash Point - Method Identified• Flammability Limits - For product, if known. The lowest and highest value of the components is listed for mixtures.• Extinguishing Media - Following National Fire Protection Association criteria.• Special Fire Fighting - Minimum equipment to protect firefighters from toxic products of vaporization, combustion, or decomposition in fire situations.• Unusual Fire Hazard - Known or expected hazardous products resulting from heating, burning, or other reactions.• D.O.T. Category - Describes the classification for shipping by road.

FIGURE 38-34

Sections of a Material Safety and Data Sheet. (Continued)

Section 4 Reactivity Hazard Data
<ul style="list-style-type: none">• Stability - If known, conditions to avoid preventing hazardous or violent decomposition.• Conditions to Avoid - If known, conditions to avoid preventing hazardous reactions.• Hazardous Polymerization - If known, conditions to avoid preventing hazardous polymerization resulting in a large release of energy.
Section 5 Health Hazard Data
<ul style="list-style-type: none">• Primary Route(s) of Entry - Based on properties and expected use.• Effects of Overexposure (Acute) - Potential local and systemic effects due to single or short-term overexposure to the eyes and skin, or through inhalation or ingestion.• Signs and Symptoms of Exposure - If known, warning signs which may indicate exposure to the skin or eyes, or through inhalation or ingestion.• Medical Conditions Generally Aggravated by Overexposure - If known, preexisting conditions which may contribute to the effects of overexposure to the eyes and skin or through inhalation or ingestion.• Emergency and First Aid Procedures - Procedures to be followed when dealing with accidental overexposures.
Section 6 Control And Protective Measures
<ul style="list-style-type: none">• Protective Equipment - Identifies equipment that may be needed when handling the product.• Ventilation - Describes the need for forced mechanical ventilation if required.
Section 7 Spill Or Leak Procedures
<ul style="list-style-type: none">• Identifies precautions to be taken and methods of containment, cleanup, and disposal.• RCRA hazardous wastes and CERCLA hazardous substances are listed in this section.
Section 8 Hazardous Material Identification
<ul style="list-style-type: none">• Provides hazardous materials identification system rating based on ratings of individual components.• D.O.T. emergency response codes are provided in this section.
Section 9 Special Precautions And Comments
<ul style="list-style-type: none">• Covers any relevant points not previously mentioned.• Reinforces pertinent points previously covered.

FIGURE 38–35

Material Safety and Data Sheet for Ferric Chloride.

Company Logo					
Material Safety Data Sheet					
Revision Date Date Sheet Prepared	Prepared by Who prepared MSDS	Technical Information Toll Free Phone Number or email address			
Home Office Company Address		Emergency Toll Free Phone Number			
Section 1: Product Identification					
Name: Ferric Chloride					
MSDS Code: XXX - Liquid; Related Part Numbers: XXX-500ML; XXX-1L; XXX-4L; XXX-20L					
Use: For etching printed circuits boards.					
Section 2: Hazardous Ingredients					
CAS#	Chemical Name	Percentage by weight	ACGIH TWA	Osha Pel	Osha Stel
7705-08-0	Ferric Chloride	40	1mg/m ³	N/E	N/E
7647-01-0	Hydrochloric acid	1	5ppm	N/E	N/E
Section 3: Hazards Identification					
Eyes:	Corrosive. Contact of liquid will cause severe eye burns, and corneal damage.				
Skin:	Corrosive. May cause severe skin irritation with possible burns.				
Inhalation:	May cause irritation of mucous membranes and respiratory tract.				
Ingestion:	May be corrosive to the gastrointestinal tract. May cause chemical burns in the mouth, throat, esophagus, and stomach.				
Chronic:	Repeated exposure may cause an increased body load of iron, with possible chronic systemic effects.				
Section 4: First Aid Measure					
Eyes:	Remove contact lenses. Flush with water or saline for 15 minutes. Get medical aid.				
Skin:	Wash skin with soap and water for 15 minutes. Get medical aid if symptoms persist.				
Inhalation:	Immediately remove from exposure to fresh air. If not breathing, give artificial respiration. If breathing is difficult, give oxygen. Get medical aid.				
Ingestion:	Do not induce vomiting. If conscious, give 1–2 glasses of water. Get medical aid.				
Section 5: Fire Fighting Measures					
Auto Ignition Temperature: N/A		Flash Point: N/A		LEL/UEL: N/A	
Extinguishing Media: N/A					
General Information: Will not burn.					
NFPA Ratings:	Health 2	Flammability 0	Reactivity 2		
HMIS Ratings:	Health 2	Flammability 0	Reactivity 2	WHMIS Codes E	

FIGURE 38-35

Continued.

Section 6: Accidental Release Measures			
Spill Procedure:	Provide adequate ventilation. Wear appropriate personal protection. Sprinkle absorbent compound onto spill, then sweep into a plastic container. Wipe up further residue with paper towel and place into container. Wash spill area with soap and water.		
Section 7: Handling and Storage			
Handling:	Wash thoroughly after handling. Avoid contact with eyes, skin, and clothing. Do not ingest or inhale. Do not expose container to heat or flame.		
Storage:	Keep from freezing. Store in a cool, dry, well ventilated area, away from incompatible substances.		
Section 8: Exposure Controls			
Routes of entry:	Eyes, ingestion, inhalation, and skin.		
Ventilation:	Use adequate general or local exhaust ventilation to keep airborne concentrations below exposure limits.		
Personal Protection:	Wear appropriate protective eyeglasses or chemical safety goggles. Wear appropriate protective clothing to prevent skin contact. Use a NIOSH approved respirator when necessary.		
Section 9: Physical and Chemical Properties			
Physical State: Liquid	Odor: Odorless	Solubility: Miscible	
Boiling Point: 110°C	Vapor Pressure: 1PSI@20°C	Vapor Density: N/E	
Specific Gravity: 1.43	Evaporation Rate: Slow	pH: 1	
Section 10: Stability and Reactivity			
Stability:	Stable at normal temperatures and pressures.		
Conditions to Avoid:	Incompatible materials.		
Incompatibilities:	Alkalis, oxidizers, corrosive to metals.		
Polymerization:	Will not occur.		
Decomposition:	Prolonged contact with metals may produce flammable hydrogen gas.		
Section 11: Toxicological Information			
Sensitization: (effects of repeated exposure)	No		
Carcinogenicity: (risk of cancer)	No		
Teratogenicity: (risk of malformation in an unborn fetus)	No		
Reproductive Toxicity (risk of sterility):	TDLo: 29mg/kg (rat)		
Mutagenicity: (risk of heritable genetic effects):	No		
Lethal Exposure Concentrations:	Ingestion (LD50): 4500 mg/kg (rat)	Inhalation (LC50): N/E	Skin (LD50): N/E

FIGURE 38–35

Continued.

Section 12: Ecological Information	
General Information:	Avoid runoff into storms and sewers which lead into waterways. Water runoff can cause environmental damage.
Environmental Impact Data:	(percentage by weight)
CFC: 0	HFC: 0
CI.Solv.: 0	VOC: 0
HCFC: 0	ODP: 0
Section 13: Disposal Information	
General Information:	Dispose of in accordance with all local, provincial, state, and federal regulations. Water runoff can cause environmental damage.
Section 14: Transportation Information	
Ground: (all sizes 4L or smaller)	Consumer Commodity
Ground: (all sizes larger than 4L)	Shipping name Feric Chloride Solution, Packing Group 3, Class 8. Shipper must be trained and certified.
Air:	Do not ship by air.
Sea:	Shipper must be trained and certified.
Section 15: Regulatory Information	
SARA (Superfund Amendments and Reauthorization Act of 1986, USA, 40 CFR 372.4)	
None of the chemicals in this product have a reportable quantity.	
EPCRA (Emergency Planning and Right to Know Act, USA, 40 CFR 372.45)	
This product does not contain any chemicals subject to the reporting requirements of section 313 Title III of the SARA of 1986 and 40 CFR part 372.	
TSCA (Toxic Substances Control Act of 1976, USA)	
All substances are TSCA listed.	
CAA (Clean Air Act, USA)	
This product does not contain any class 1 ozone depletors.	
This product does not contain any class 2 ozone depletors.	
This product does not contain any chemicals listed as hazardous air pollutants.	
California Proposition 65 (Chemicals known to cause cancer or reproductive toxicity, May 1, 1997 revision, USA)	
This product does not contain any chemicals listed.	
Section 16: Other Information	
Definitions:	N/A = not applicable, N/E = not established
Disclaimer:	This material safety data sheet is provided as an information resource only. The information contained herein is accurate and compiled from reliable sources. It is the responsibility of the user to verify its validity. The buyer assumes all responsibility of using and handling the product in accordance with federal, state, and local regulations.

Recipients of material safety data sheets should consult the OSHA Safety and Health Standards for general guidance on control of potential occupational health and safety hazards.

38–8 QUESTIONS

1. What is the purpose of an MSDS?
2. What is the first thing a person should do when unpacking a shipment of chemicals?
3. What happens when a school/employer fails to provide students/employees the MSDS to be read when they are working with chemicals?
4. What are the sections of an MSDS?
5. Who should be contacted regarding general guidance of potential health and safety hazards?

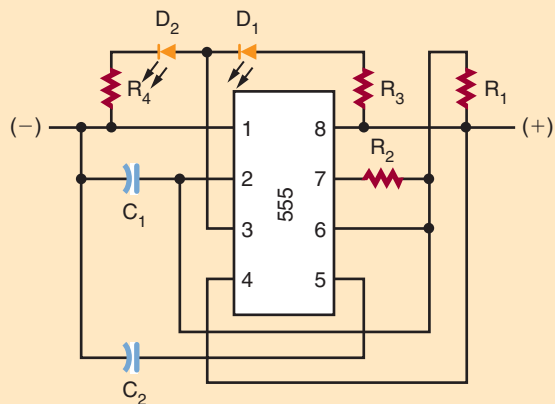
SUMMARY

- A printed circuit board (PCB) consists of an insulating base material, which supports the copper traces.
- The insulating base material is typically phenolic or epoxy fiberglass.
- The thickness of the copper is designated in ounces and refers to the weight of one ounce of copper spread over one square foot.
- The desired traces are printed onto the copper with a material called resist.
- The etchants most often used for etching small quantities of printed circuit board are ferric chloride and ammonium persulphate.
- Commercial printed circuit board fabricators use different chemicals that are less expensive, such as ammonium chloride that is heated with additional agents to improve performance.
- SMT allows components to be placed on both sides of the printed circuit board.
- Two additional layers, the silkscreen layer and the solder mask layers, are applied to a printed circuit board after it is etched.
- In theory, a single layer is all that is necessary with through-hole passive components and discrete transistors.
- Most RF boards have traces on only one side, with a second layer used as a ground plane to improve performance.
- More than two layers on a printed circuit board are used for dense, highly populated boards or for performance considerations.
- A well-organized schematic that shows smooth signal flow and complete information is the key to effective printed circuit board design.
- The best way to preview a schematic diagram is to lay out or view a block diagram of the circuit.
- Digital schematic diagrams appear different from analog schematic diagrams due to differing interconnection patterns.
- A schematic diagram should show the entire circuit in as few drawings as possible.
- Computer programs can assist in the generation of a schematic diagram.
- Breadboarding is essential to proving a circuit design works by allowing circuits to be assembled and altered quickly.
- Computer programs allow virtual breadboarding, testing of a circuit, and troubleshooting using virtual test equipment.
- A number of decisions must be made before a printed circuit board can be laid out.
- A printed circuit board design can be laid out using paper dolls of each component.
- During the layout process, the printed circuit board is viewed from the component side or top.
- The goal in laying out a printed circuit board is to have no crossed traces and to

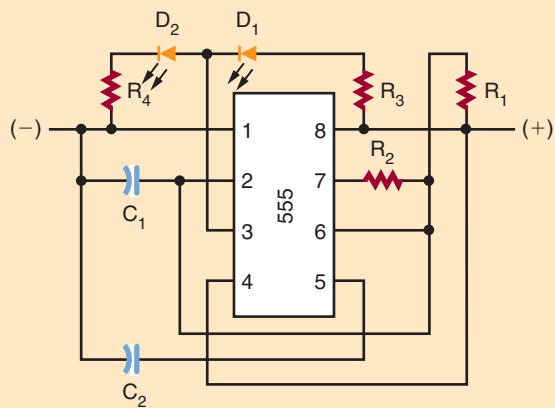
- have the layout resemble a physical relationship of the schematic diagram, which is useful in troubleshooting.
- Jumpers can be used for crossed traces on a single-side board.
 - A pad is used to connect a lead from a component or wire from an off-board component.
 - Printed circuit boards are easier to manufacture if the traces are wide and far apart.
 - Traces that are too thin are fragile have higher resistance than thick traces and handle less current.
 - Traces that are placed close together may short out and can be electrically coupled to each other.
 - Avoid using acute angles of more than 90° in laying out traces.
 - When the layout is finished, increase the width of the power and ground traces as much as possible.
 - Use a color-coded system to simplify the presentation of a double-sided printed circuit board during the design process.
 - Surface mount technology (SMT) adds more facets to printed circuit board layout.
 - Autorouters are designed to use the computer to lay out a printed circuit board.
 - Getting a printed circuit board made commercially requires a design to be sent to a service.
 - The Gerber format is a standard printed circuit board format that defines the trace placement.
 - The aperture file defines the physical size with a short list of “flash codes.”
 - The drill file informs the manufacturer of where the holes are located and what size they are.
 - Transferring the artwork to the copper-clad board can be done by hand, with transparency film, and through screenprinting.
 - Copper can be removed from a copper-clad board to form a printed circuit board by using a mild acid such as ferric chloride or ammonia persulphate or by using a CAD-type program with a CNC (computer numerical control) machine.
 - After the printed circuit board has been etched the resist needs to be removed from it.
 - The printed circuit board can be treated with a tin-plated solution to stop oxidation of the copper.
 - Types of defects in fabricating a printed circuit board include traces that are bridged or shorted together and traces that are open.
 - Use a high-speed drill for drilling all holes in a printed circuit board.
 - A material safety data sheet (MSDS) is a document supplied with the purchase of a chemical as defined by the Occupational Safety and Health Administration (OSHA).
 - The MSDS contains the data needed for the safe handling and storage of the hazardous substance.
 - Make sure an MSDS folder can be easily found in the location where the chemical is being used.
 - Everyone who uses a chemical product must understand its dangers and the precautions that must be taken while using it.

CHAPTER 38 SELF-TEST

1. What is the function of a printed circuit board?
2. Redraw the following sketch as a proper schematic diagram.



3. Using the schematic shown in question 2, manually lay out a single-sided printed circuit board that has no jumpers.
4. Redraw the following sketch as a block diagram.



5. Locate an MSDS for ammonia persulphate acid and identify the proper storage procedure and whether it is okay to heat it.

Printed Circuit Board Assembly and Repair

OBJECTIVES

After completing this chapter, the student will be able to:

- Describe the items in an electronics technician's toolbox and explain their function.
- Identify the different types of test equipment used for troubleshooting.
- Identify the purpose of different types of soldering irons and tips.
- Describe proper soldering iron tip care.
- Describe how to solder components on an etched printed circuit board.
- Identify the appearance of a properly soldered connection.
- Understand and observe all safety precautions associated with the fabricating, assembly, and soldering of a printed circuit board.
- Discuss the importance of electrostatic discharge (ESD).

An **electronics technician** uses a variety of tools to build and repair electronic circuits on printed circuit boards. These tools coupled with electronic test equipment allow the technician to analyze any electronic circuit for proper operation or identify faulty circuit components and repair them. The right tools make the job easier for an electronics technician.

39-1 ELECTRONICS TECHNICIAN TOOLBOX

The installation and repair of components in a printed circuit board may be accomplished through the use of tools designed specifically for the task. Figure 39-1 shows some of the tools in an electronics technician's toolbox.

Figure 39-2 shows two types of printed circuit board holders for holding a printed circuit board while it is being assembled or repaired. The fixtures should provide good support and should be rotatable.

An illuminated magnifier, shown in Figure 39-3, provides a means of detecting improper connections or broken traces on the printed circuit board. It also helps when soldering SMT components to a printed circuit board.

FIGURE 39-1

Tools used by an electronic technician for printed circuit board fabrication and repairing.





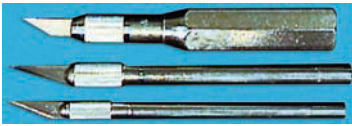
ITEM	PICTURE	DESCRIPTION
Plastic And Orangewood Spudgers		Used for lifting wires and pushing/aligning leads
Bristle And Acid Brushes		Applying solvent to PCB for cleaning
Wire Strippers		To strip the end of insulated wire leads
Surgical Scissors		General cutting
X-Acto Knife		General cutting, removal of bridges on PCB

FIGURE 39-1

Tools used by an electronic technician for printed circuit board fabrication and repairing. (Continued)






ITEM	PICTURE	DESCRIPTION
Tweezers		Aid to lifting small components
Flat Nose Pliers (Duck Bill)		Straighten component leads
Needle Nose		Form leads
Round Nose Pliers		Form leads
Diagonal Cutters (Flush)		Cut leads flush to PCB and general lead trimming

FIGURE 39-1

Tools used by an electronic technician for printed circuit board fabrication and repairing. (Continued)




ITEM	PICTURE	DESCRIPTION
Screwdrivers (Flat blasé, Phillips)		Install/remove screws
Nut Drivers		Install/remove bolts and nuts
1/16" And 1/8" Chisel Tip For Soldering Iron		Options for components to be soldered
Heat Sinks		Used to remove excess heat with semiconductors

FIGURE 39-1

Tools used by an electronic technician for printed circuit board fabrication and repairing. (Continued)

Alcohol And Flux Bottle



Use to hold alcohol and flux

Soldering Iron



Used to solder

Solder Wick



Used for solder removal

Manual Desoldering Tool



Used for solder removal

FIGURE 39-2

Examples of printed circuit board holders.



Figure 39-4 shows special tools used to assist with the forming of leads of resistors for installing in a printed circuit board.

FIGURE 39-3

Illuminated magnifier.



FIGURE 39-4

Component lead former tool.



39-1 QUESTIONS

1. List the tools that would be included in an electronics technician's toolbox.
2. Where might duckbill pliers be used?
3. What type of device is used to hold a printed circuit board?
4. Where would an illuminated magnifier be used?

5. How can the leads of a resistor be accurately formed for insertion into the printed circuit board?

39-2 ELECTRONIC TEST EQUIPMENT

Electronics technicians use a variety of test equipment for determining proper operation, aligning components, and troubleshooting a circuit.

The table in Figure 39-5 shows a sample of test equipment available to electronics technicians and explains their function.

An **isolate power supply** is important when powering a circuit to prevent it from generating a lethal shock potential. Power supplies are available that generate DC voltage and/or AC voltage. Both fixed and variable voltage power supplies are available. The power supply is used to supply a circuit with the correct voltage for testing and troubleshooting.

Analog and digital multimeters are the first pieces of equipment used to analyze a circuit. To

FIGURE 39-5

Test equipment used by an electronic technician for determining proper operation, alignment or troubleshooting of a circuit.







ITEM	PICTURE	DESCRIPTION
Isolated Power Supply		Used to power a PCB under test.
Analog Multimeter (VOM)		Used to measure and/or align voltage, resistance and current of a PCB under test.

FIGURE 39-5

Test equipment used by an electronic technician for determining proper operation, alignment or troubleshooting of a circuit. (Continued)

ITEM	PICTURE	DESCRIPTION
Digital Multimeter (DMM)		Used to measure and/or align voltage, resistance and current of a PCB under test.
Analog Oscilloscope		Used to measure and/or align amplitude, frequency and compare waveforms.
Frequency Counter		Used to measure and/or align frequency and period of recurring signals.
Signal Generator		Used to generate a sinusoidal waveform for troubleshooting and aligning an electronic circuit.

prevent possible circuit damage the meter should have a sensitivity of more than 20,000 ohms per volt on the voltage scales. The meter should also not pass more than one milliamperes of current on the resistance scales. Static DC and resistance

checks will usually locate power failures or defects that exhibit large deviations from the normal on the printed circuit board. However, these methods are time consuming and inadequate when the defect is intermittent in the circuit.

FIGURE 39-5

Test equipment used by an electronic technician for determining proper operation, alignment or troubleshooting of a circuit. (Continued)

Function Generator



Used to generate a sinusoidal, triangular or square waveform for troubleshooting and aligning an electronic circuit.

Logic Probes



Used to detect a high, low, clock or lack of a signal in digital electronic circuits.

Logic Pulser



Used to inject a digital signal into a digital circuit for troubleshooting.

An oscilloscope is one of the most useful pieces of test equipment available to the electronics technician. It can identify defects in a circuit while it is powered up; this includes changing parameters of a circuit. It displays the instantaneous voltage on the vertical axis against time on the horizontal axis. The oscilloscope can detect both DC and AC signals. Some oscilloscopes allow the comparison of two waveforms of the same frequency to determine the phase shift. The oscilloscope probe on most oscilloscopes will allow switching between settings of 1X and 10X (Figure 39-6). When the signal exceeds the capability of the oscilloscope on the 1X setting, the 10X setting multiplies the voltage setting of the oscilloscope by ten and makes viewing the signal possible.

Frequency counters are useful for measuring the frequency and period of a recurring signal.

FIGURE 39-6

Oscilloscope probe.



They provide a digital readout of the frequency. Frequency measurements are an important part of preventive and corrective maintenance of electronic equipment.

Signal generators are used in the testing and aligning of radio transmitters, receivers, and amplifiers. They are also used for troubleshooting various electronic devices that require an input signal. Signal generators produce an alternating voltage of a desired frequency and amplitude for testing or measuring a circuit. Signal generators are classified by their frequency into the following categories: audio generator, video signal generator, radio-frequency generator, frequency-modulated RF generators, and special types of signal generators that combine several or all of the frequency ranges.

A **function generator** is a type of signal generator and is a common piece of electronic test equipment. The function generator is capable of generating fundamental waveforms such as sine waves, triangular waveforms, and square waveforms. The voltage, symmetry, and time characteristics of a waveform can be adjusted to meet a specific application.

A **logic probe** contains LEDs that produce a visual indication of what is occurring at a specific point in a digital circuit. It can indicate a high, low, clock, or lack of a signal. It can be used with a **logic pulser**, which looks similar to the logic probe. The pulser injects a logic level into a circuit, which can be picked up by the logic probe. The logic probe is useful for checking signals of various input and output pins of a circuit or an IC.

39-2 QUESTIONS

1. Why does an electronics technician use test equipment with a printed circuit board?
2. Why use an isolated power supply when working on or testing a circuit?
3. Discuss the difference between a 1X probe and a 10X probe.
4. How does a function generator differ from a signal generator?
5. What type of circuit would a logic probe be used for?

39-3 SOLDER AND SOLDERING IRONS

Soldering is the joining of two pieces of metal alloy having a melting point below 800° Fahrenheit. Solder includes a combination of tin and lead. Tin-lead solder ranges from pure tin to pure lead and all proportions in between. In electrical soldering, the alloy mix is usually 60% tin and 40% lead (60/40) or 63% tin and 37% lead (63/37) (Figure 39-7). For soldering **surface mounted devices**, a solder is available with 62% tin, 28% lead, and 2% silver (62/36/2).

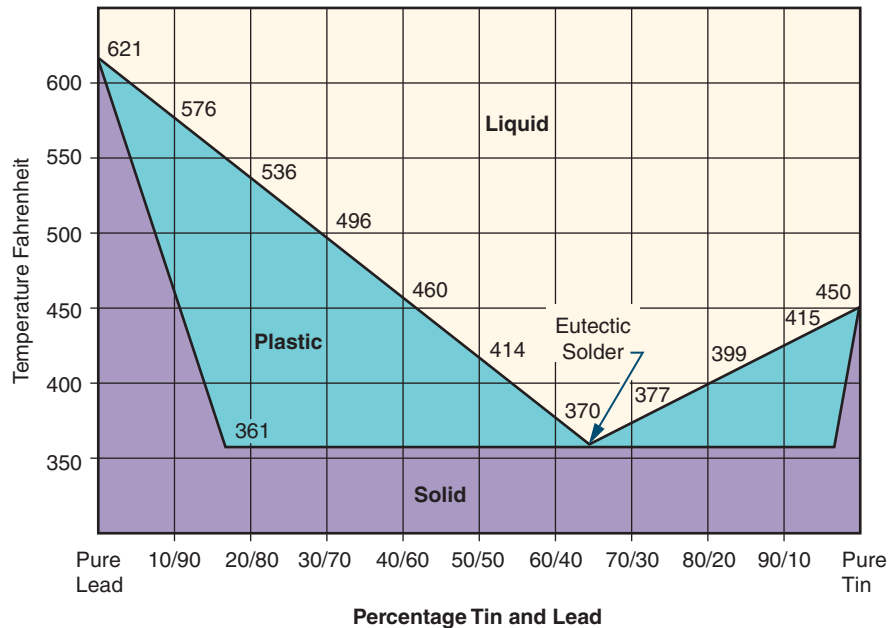
Characteristics of alloys of tin and lead are plotted against temperature in Figure 39-8. This graph allows one to see that only an alloy of 63/37 has a eutectic point (a single melting point). All other combinations start melting at one temperature, pass through a plastic stage, and then become a liquid at a higher temperature. Any physical movement of the components being soldered while the solder is in the plastic stage will result in a **fractured solder connection**. Such a connection will appear dull and grainy, and is

FIGURE 39-7
Spool of solder.



FIGURE 39-8

Solder alloy versus temperature.



mechanically weaker and less reliable. Therefore, 63/37 or 60/40 solder is commonly used in electronics because it does not remain in the plastic stage very long.

Flux helps the solder alloy flow around the connections. Flux cleans the component leads of oxide and film, allowing the solder to adhere. Soldering flux is usually included in the solder in the central core. Rosin flux is always used in electrical soldering because it is noncorrosive.

The primary tool used for installing, removing, and/or replacing components on a printed circuit board is the **soldering iron**. An improper choice in selecting a soldering iron or **soldering iron tip** may result in damage to the component and/or the printed circuit board. Select only a low-wattage **pencil soldering iron** (Figure 39-9) with an appropriate tip for the soldering being done. **Solder guns** (Figure 39-10) are inappropriate for printed circuit board fabrication. They are designed to

FIGURE 39-9

Example of low wattage pencil soldering iron.



supply heat to large electrical connections and will ruin the small detail of a printed circuit board.

The soldering iron is usually specified by wattage. In most situations a 25- to 35-watt soldering iron is adequate. Wattage represents the

FIGURE 39-10

Solder gun.



FIGURE 39-11

Several types of pencil soldering iron.



amount of heat capacity available at the tip. Soldering irons of all wattages usually run at the same temperature. A low-wattage soldering iron will tend to cool faster during the soldering process than a high-wattage soldering iron. The handle of the soldering iron should be comfortable to hold and should be well insulated to prevent heat buildup. Soldering irons can produce static voltage spikes that will destroy many integrated circuit components. A grounded soldering iron tip is a good safety measure. Figure 39-11 shows several types of soldering irons suitable for printed circuit boards. The least expensive is the pencil soldering iron, and with proper care it will last many years. The **temperature-controlled soldering station** provides precise tip temperature through a closed loop circuit. It maintains a constant tip temperature throughout the soldering process. The cordless soldering iron is similar to the pencil soldering iron except it uses a battery for its power source.

Iron-clad tips are the best selection for soldering printed circuit boards. An unplated tip will provide better heat transfer but wears rapidly and requires

frequent cleaning and tinning. The iron-clad tip requires only an occasional cleaning and tinning.

Soldering iron tips come in a wide variety of shapes and sizes to meet a specific application. Many soldering irons have replaceable tips. The tip selected should provide maximum contact area between the surfaces to be joined and also allow accessibility to the connection. Figure 39-12 shows the most popular shapes of soldering iron tips. Typically a small bevel tip is preferred for general printed circuit board work.

Maintaining the soldering iron tip is essential for proper soldering. Use an antiseize compound when installing the tip to prevent it from becoming frozen. Make sure the tip is fully installed in the heating element. Clean the tip with steel wool prior to heating it. Heat the tip and apply solder as it warms up. Applying solder to the tip is called *tinning*. Rest the soldering iron on a stand to remove excess heat from nontemperature-controlled soldering irons, as shown in Figure 39-13. This is referred to *idling*. Wipe the tip of the soldering iron across a damp sponge or tip cleaner to clean it of any oxidation prior to soldering.

FIGURE 39-12

Soldering iron tips.









SOLDERING IRON TIP			DESCRIPTION
TYPE	END VIEW	SIDE VIEW	
CONICAL			Used for general assembly and repair
PYRAMID			Used for general assembly and repair
BEVEL			Allows rapid transfer of heat. Used for printed circuit boards.
CHISEL			Allows large areas to be heated rapidly. Used for tinning wires, soldering terminals.

FIGURE 39-13

Tinning soldering iron.



39-3 QUESTIONS

1. What is the primary tool used for installing a component on a printed circuit board?
2. A soldering iron used for printed circuit board work should be of what wattage?

3. Why should the soldering iron tip be grounded?
4. What is the best tip for soldering on a printed circuit board?
5. How is the tip of a soldering iron tinned?

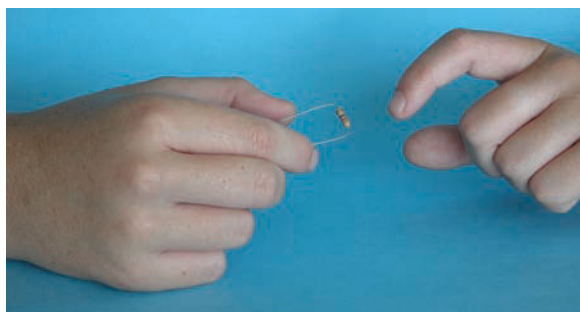
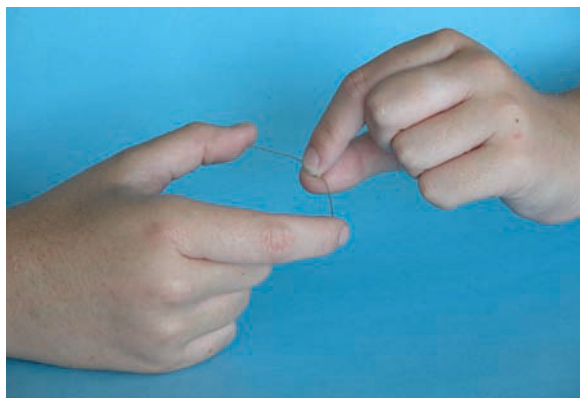
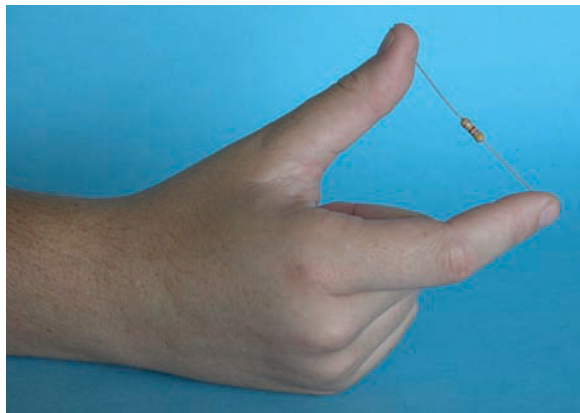
39-4 SOLDERING A PRINTED CIRCUIT BOARD

Use a systematic method for installing components on the printed circuit board. One technique is to install all the resistors first, then the capacitors, ICs, and so on.

With axial components the leads need to be bent at a right angle. Grasp the ends of the component between the thumb and index finger and pull the body outward while maintaining a grip on the ends of the leads (Figure 39-14). The component should now fit between the pad mounting holes. Position components so the values can be

FIGURE 39-14

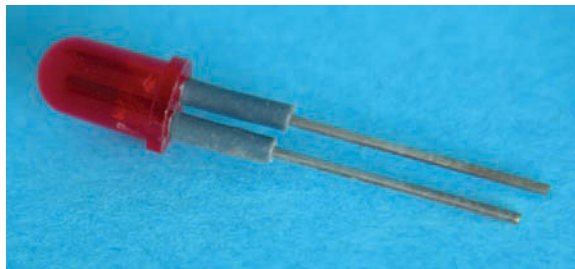
Manually bending component leads.



easily read. Arrange resistors so the value can be read top to bottom or left to right. Observe polarity of all polarized components and orientate them properly on the printed circuit board. Pay

FIGURE 39-15

Example of leg warmers.



close attention to installing ICs on the printed circuit board to ensure pin 1 is lined up with its appropriate location on the board. Use 1/4" **leg warmers** on LEDs and small transistors to avoid overheating (Figure 39-15). After the component leads have been inserted and prior to soldering, they should be bent to a 45° angle to keep them from falling out.

Once the printed circuit board is assembled, the next area to consider is the off-board components (potentiometers, lamps/LEDs, switches, transformers, etc.). A wiring diagram will make the installation clear and easy to understand. The two types of drawings are the pictorial diagram (Figure 39-16) and the functional diagram (Figure 39-17). There is no standard color code for wiring a printed circuit board. It is best to use different color wires for each discrete component and note the colors on the wiring diagram. There typically aren't enough colors for each signal to have its own color, but different colors can be used to denote different classes of signals.

When constructing a diagram, one set of signals that should be color-coded is power and ground. A different color for the positive voltage, negative voltage, and ground should be used. These colors should not be any of the colors that have been used for other signals. It would be nice to use "standard" colors for these, but unfortunately there are several competing standards. Red is frequently used to indicate the positive supply

FIGURE 39-16

Example of a pictorial diagram.

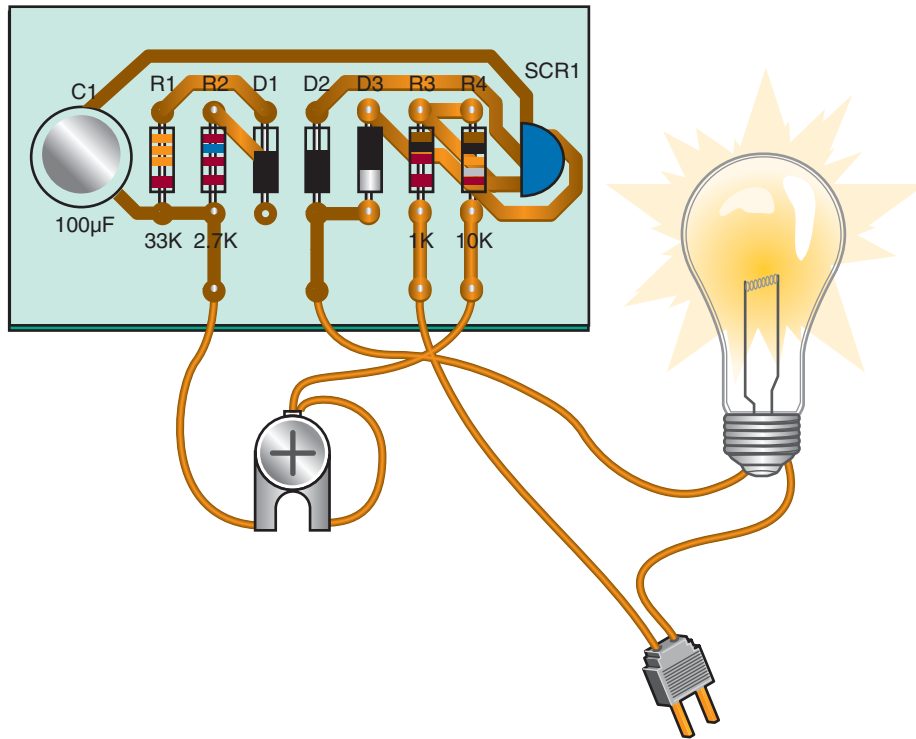
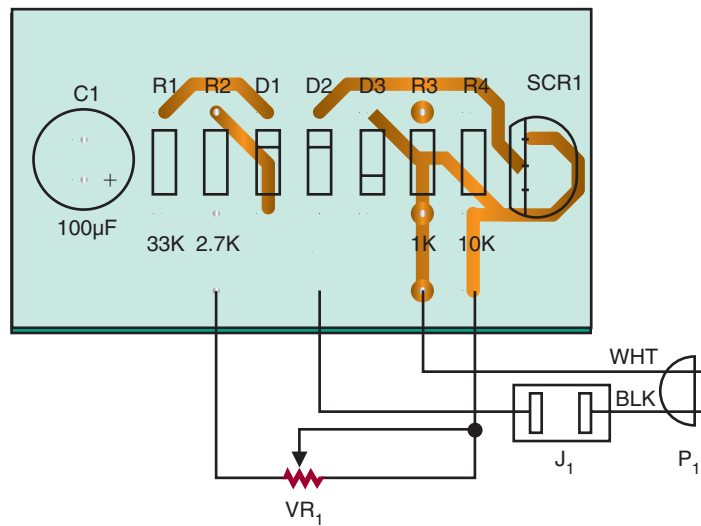


FIGURE 39-17

Example of a printed circuit board functional diagram.



voltage. Most automotive and electronic wiring diagrams use black to denote ground. Electronics wiring that uses black for ground often uses blue for negative supply voltage. Green is frequently used to denote ground.

In electronics, the basic goal of soldering is to electrically and mechanically join two circuit components. For soldering to be successful and reliable, the solder must adhere to the mating surface. The application of solder to a base metal requires the surface to be clean and free of contamination. If the surface to be soldered is contaminated, the solder tends to ball up and not adhere. Sources of contamination include greases, oils, and dirt. Aging also causes surface contamination by the formation of an oxide film.

The best soldering techniques can be outlined simply. First, wipe the tip of the soldering iron on a damp sponge. Then place a small amount of solder on the tip and apply the tip to the connection to be soldered. Solder should not be applied until the connection becomes hot enough to melt the solder. How long this takes is quickly learned by a few trials and errors. When the solder has melted and flowed into a con-

toured fillet, remove the solder. Keep the tip of the soldering iron on the connection for a few seconds longer, and then remove it. Do not disturb the newly made connection until it has had time to solidify. A good solder connection will be bright and shiny (Figure 39–18).

Handle components and the printed circuit board as little as possible because fingers may be dirty and oily. If there is a question about the cleanliness of a part, clean it using alcohol, steel wool, or a scouring powder. When using scouring powder, ensure that the parts are rinsed thoroughly. If steel wool is used, use a lint-free cloth to remove all pieces of the steel wool from the part or printed circuit board.

Soldering on a printed circuit board requires careful attention because of the heat sensitivity on the pads and traces. Too much heat with too much pressure can cause a pad to lift from the board substrate. Always apply the tip with a light touch—practice will determine approximately how long it needs to be held. The soldering iron should rest on the junction of the lead and pad rather than being pressed to it (Figure 39–19).

FIGURE 39–18

Example of a good solder connection.

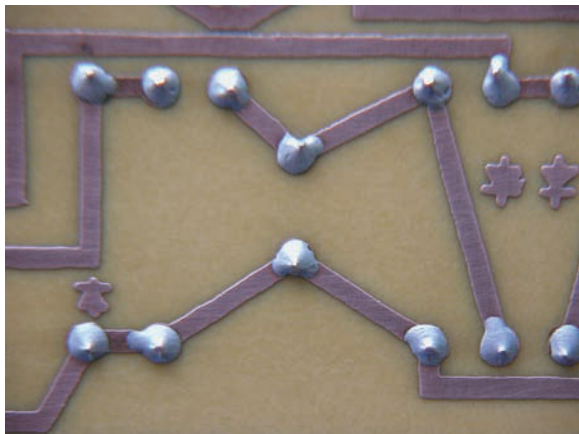
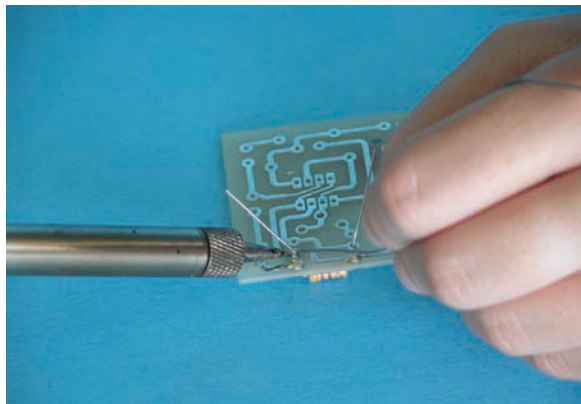


FIGURE 39–19

Place the soldering iron tip at the junction of lead and the pad with no pressure.



To summarize proper soldering technique:

1. Wipe tip on a damp sponge or tip-cleaning apparatus.
2. Tin the tip by applying solder to it.
3. Apply the tip to both the component lead and pad.
4. Apply solder to the back of the connection; the heat of the tip will draw it to it.
5. Remove the solder.
6. Remove the tip from the connection.
7. Let the connection cool.
8. Trim the excess leads flush to the printed circuit board.

During the soldering process a flux residue forms on the printed circuit board. The residue is noncorrosive in most cases. However, it should be removed as it is sticky and foreign particles can attach to it. Also, removing the flux makes the inspection of the board easier and gives a more professional appearance to the board. There are several **defluxers** on the market that make removing easy. Unfortunately, they are not environmentally friendly because they contain trichlorotrifluoroethane as their main ingredient.

To use the **flux cleaner**, spray the surface to be cleaned in a well-ventilated area. Allow the chemical to saturate the board for ten to fifteen seconds, and then clean it with a medium-bristle brush such as an acid brush. Allow the components to dry completely before powering up the circuit.

Once the skill of soldering is mastered, the skill of **desoldering** is next. Desoldering requires special implements: desoldering braid, desoldering bulb, desoldering pump, combination bulb and soldering iron, and desoldering station.

In desoldering the first step is to solder. Applying more solder on the connection ensures the connection is heated up prior to removing the solder. Do not heat a connection with very little solder, as it will result in the pad lifting from the substrate.

FIGURE 39–20

Desoldering braid.



A desoldering braid consists of a braided copper material with flux imbedded in it that uses capillary action to pull up the hot solder (Figure 39–20). Using the widest braid practical, place it on the pad to be desoldered. Place a hot soldering iron on top of the braid. The solder will melt and be wicked into the braid. When the braid gets saturated, remove it, clip off the saturation end with diagonal cutters, and reapply until the solder is removed. Use a hot soldering iron—the braid acts like a heat sink, cooling the soldering iron tip.

The **desoldering bulb** uses a bulb and a teflon tip. Squeeze the bulb and apply the tip to the melted solder; releasing the bulb draws up the molten solder (Figure 39–21).

A variation of the desoldering bulb is a spring-loaded **desoldering pump** (Figure 39–22). It works by depressing a plunger until it locks. To suck up solder, press the release button. The spring forces the plunger up rapidly, creating a vacuum.

The combination rubber bulb and soldering iron uses a hollow tip to suck up the solder (Figure 39–23). It eliminates the rush to get the solder sucker to the pad before the solder rehardens.

FIGURE 39-21

Using a desoldering bulb.



FIGURE 39-22

Solder pump.



FIGURE 39-23

Combination desoldering bulb and soldering iron with a hollow tip.



A professional desoldering station uses a foot-operated vacuum pump and a hollow-tip soldering iron to draw up molten solder. It is the most expensive tool used for desoldering a component from a printed circuit board pad.

Any of the desoldering tools discussed will do the job of removing solder from a printed circuit board connection. Each requires different techniques and fits different budgets.

The mounting or removal and replacement of components for SMT (surface mount technology) printed circuit boards is different than in conventional printed circuit boards.

With SMT printed circuit boards, in addition to the board being smaller, the components are much smaller and must be handled with tweezers. Mount the printed circuit board in a vise. This allows stability when using a magnifying glass to work on the circuit.

The proper method for removing SMT components is with a rework station. To desolder SMT components manually, proceed as described in the next paragraphs.

For an IC remove as much solder as possible from the connection using 0.030"-diameter desoldering braid. The only solder remaining is holding the component leads to the printed circuit board. Wipe the soldering iron clean and heat the lead and pad while using an X-Acto knife to gently pry up the lead. When the lead releases, remove the soldering iron and allow the lead to cool. Repeat on each lead until the IC is removed from the printed circuit board.

CAUTION: TOO MUCH PRYING PRESSURE CAN LIFT THE PAD.

For SMT resistors and capacitors, add solder to the pad to increase the thermal mass to prevent it from cooling too fast. Alternately heat each end and use tweezers to remove the component while the solder is molten. Use desoldering braid to remove the excess solder.

The solder used should be 63/37 or a silver bearing solder of 62/36/2 with a diameter of 0.020" to 0.015". A noncorrosive liquid flux with a drop dispenser and a light-duty spray defluxer is required for applying and cleaning flux on the SMT leads. Clear tape is useful for taping down components prior to soldering.

After the printed circuit board is completely assembled and soldered, apply power. If the circuit works properly, enjoy. Otherwise, troubleshoot by first removing power from the printed circuit board. Inspect all traces for bridging or breaks and all solder connections for shorts. Check for improper solder connections. Correct all problems and retest.

39-4 QUESTIONS

1. What is an effective method for installing the components on a printed circuit board?
2. What should be observed when placing nonpolarized components on a printed circuit board?
3. What function do leg warmers serve on LEDs and small transistors?
4. What is the guideline for color wires when installing discrete components?
5. What is the best solder mixture for effective printed circuit board soldering?
6. What is the best tip to use for general printed circuit board soldering?
7. List the steps for effective soldering on a printed circuit board.
8. What tools are required for desoldering a component on a printed circuit board?
9. How can the flux residue be removed from the soldered printed circuit board?
10. What is different when soldering SMD components as compared to full-size components?

39-5 ANALYZING SOLDERED CONNECTIONS

The surface of a properly soldered connection should be smooth, well feathered at the edges, and bright and shiny with a slight concave configuration (Figure 39-24).

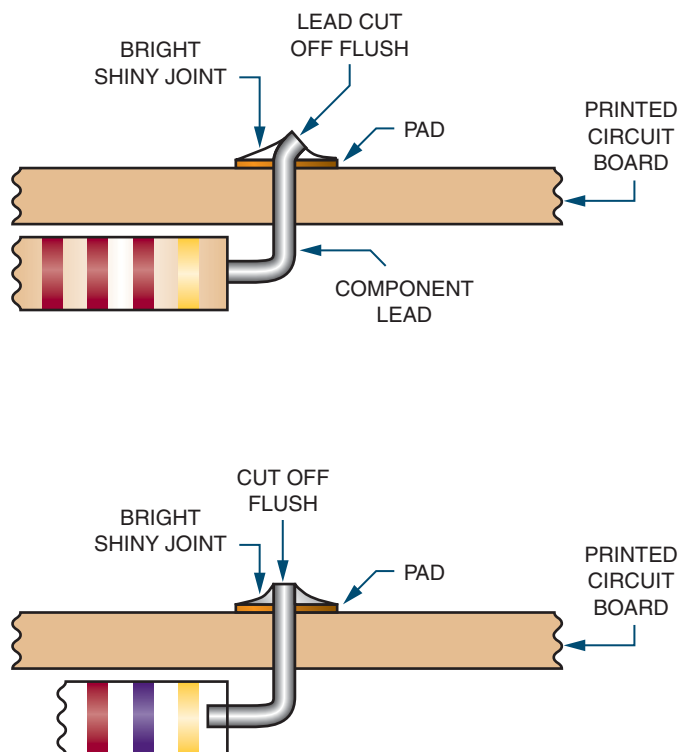
Two of the most common soldering defects include cold solder connections and disturbed or fractured connections. **Cold solder connections** are the result of withdrawing the soldering iron too soon. The solder does not become liquid and leaves a connection that is dull gray in appearance. A **fractured** or **disturbed connection** is the result of movement of the component leads or wire before the solder sets. The fractured joint is evident by a granulated and frosty appearance with many cracks showing.

Other types of defects include:

- **Rosin connection** is caused by the flux and oxidation particles staying between the solder pad and lead. It is the result of not enough heat.
- **Wicking** is caused by the capillary action of stranded wire. It is the result of too much heat.
- **Voids** are caused by impurities in the surface when soldering. They are the result of too much heat.
- Removing the solder too soon results in not enough solder.
- Too much solder is caused by not removing the solder soon enough.
- **Bridging** (inadvertently connecting two pads) is caused by not removing the solder soon enough.
- Damage to a component is caused by too much heat—the iron is too large or held on too long.

FIGURE 39–24

Characteristic of a solder connection.



39–5 QUESTIONS

1. Describe what a properly soldered connection should look like.
2. Draw a picture of a properly soldered component on a printed circuit board.
3. What are the two most common types of soldering defects?
4. What causes the most common defects on a printed circuit board?
5. List other types of defects that may occur when soldering.

39–6 PROTECTIVE COATINGS

Conformal coatings are nonconductive materials applied in a thin layer on printed circuit boards. They provide environmental and mechanical protection to significantly extend the life of the components and circuitry. Conformal coatings are traditionally applied by dipping, spraying, or flow coating.

Conformal coatings protect electronic printed circuit boards from abrasion, corrosion, dust, fungus, moisture, and environmental stresses. Common conformal coatings include acrylic, epoxy,

parylene, silicone, and urethane. Most conformal coatings consist of a synthetic resin developed in a volatile solvent. When they are properly applied to a clean surface, the solvents evaporate, leaving a thin film of solid resins. Conformal coatings have one or more of the following characteristics to protect the printed circuit board effectively:

1. Good thermal heat conductivity to carry heat away from the components.
2. Inorganic composition to prevent fungus growth.
3. Low moisture absorption.
4. Low shrinkage factors during application and curing to prevent coating from applying strains or stresses to the components or leads.
5. Resilience, hardness, and strength to support and protect the components.
6. Qualities of electrical insulation.

39-6 QUESTIONS

1. What are conformal coatings?
2. What is the purpose of conformal coatings?
3. How are conformal coatings applied?
4. What materials are used for conformal coatings?
5. What are the characteristics of a good conformal coating?

39-7 SAFETY PRECAUTIONS

Effective **safety** habits are necessary to succeed in the electronics field. Practicing good safety habits promotes a safe work environment. Everyone needs to be aware of and support a safe work environment.

A primary concern in the field of electronics is **electrical shock**. Electrical shock is the passage of current through the body. Current can flow through

the body just as it does through an electrical circuit. How much current flows depends on these factors:

- Body resistance is high if the skin is dry and there are no cuts or abrasions at the point of electrical contact. This results in little current flow with only a mild shock.
- Body resistance is low if the skin is moist. This results in a high current flow, and if the current flow is through the chest region the heart can receive a lethal dose of current. The heart may go into fibrillation and breathing may be stopped (Figure 39-25).

Small amounts of current through the body can be dangerous to one's health. Large amounts of current through the body can be fatal. A shock of 1 to 20 mA can cause a painful sensation. At a shock of approximately 20 to 30 mA, breathing will be stopped. A shock above 100 mA will result in electrocution.

The work environment should be reviewed to identify problem areas. Maintaining a safe work environment is easy when observing the following guidelines:

1. Keep the work area neat and orderly.
2. Be alert and attentive at all times.
3. Know the correct operation and safety procedures of test equipment, tools, and machinery.
4. If an accident occurs, know what action to take.

NOTE: IF A CHEMICAL IS INVOLVED CHECK THE MSDS. BASIC FIRST-AID AND CPR (CARDIOPULMONARY RESUSCITATION) TRAINING IS ESSENTIAL FOR WORKING IN THE FIELD OF ELECTRONICS.

Personal safety when working with electricity requires the following:

- Work with one hand in back pocket or behind back when working on live circuits. This technique avoids a complete path for current flow that passes through the heart region.

FIGURE 39–25

Hazards of current flow through the human body.

SENSATION FELT	CURRENT IN AMPERES AT 60 HERTZ	
	WOMEN	MEN
Can not feel anything	0.0003	0.0004
Tingling—mild sensation	0.0007	0.0011
Shock, not painful, can let go	0.0012	0.0018
Shock, painful, can let go	0.006	0.009
Shock, painful, barely let go (threshold), may be thrown clear	0.0105	0.016
Shock, painful, severe, can not let go, muscles immobilized, breathing stops	0.015	0.023
Ventricular fibrillation, fatal,		
Length of time—0.03 seconds	1.0	1.0
Length of time—3.0 seconds	0.1	0.1
Heart stops for the length of time current flows, heart may start again if current flows a short time	4	4
Burning of skin, usually not fatal unless heart or other vital organs are burned	5 or more	5 or more
Cardiac arrest, severe burns, and probable death	10,000	10,000

- Use an isolation transformer when working on AC-powered equipment. The transformer isolates the powered equipment from the power source.
- Make sure all capacitors are discharged before beginning troubleshooting. Use a capacitor discharge tool to discharge the capacitor.
- Use grounded line cords and polarized plugs with AC-operated equipment and circuits. They help to reduce the danger from hot chassis.
- Keep hands off of live circuits. Test all circuits prior to working on them with a voltmeter or test lamp.

Prior to handling toxic and hazardous chemicals, read the MSDS to know the best protection

and first-aid procedures in case of emergency. When around these types of chemicals, be concerned about inhaling vapors, swallowing liquids, acid burns on the skin, contact with the eyes, and danger of fire and explosions. Follow these guidelines to minimize risk:

- Read the labels of all chemicals being used, paying special attention to the printed warnings.
- Work in well-ventilated areas, especially when working with paint and chemical sprays.
- Wear safety glasses when working with hazardous chemicals.
- Wear rubber gloves when working with acids and acid solutions.

- Use tongs or rubber gloves when placing or removing printed circuit boards from the acid solution.
- Clean all tools that contact hazardous chemicals in case anyone accidentally touches them.

Safety is the number one priority when soldering. Always follow these safety guidelines:

1. Always wear safety glasses when soldering or cutting leads. When clipping leads on the printed circuit boards, flying leads can be an eye hazard. When clipping leads, aim down and away from the face and anyone close.
2. Never touch the soldering iron tip or heating element. Only pick up the iron by the handle. Never change the tip when the iron is hot.
3. Beware of fingers slipping over the iron handle and contacting the heating element.
4. Beware of pressing the soldering iron too hard against the leads when heating. The soldering iron may slip.
5. Beware of molten solder dripping from the connection. Cotton and wool clothing are the safest to wear when soldering. Many synthetics will melt on the skin if molten solder gets splashed on them, causing a greater burn.
6. Use care when handling printed circuit boards. Leads can cut or puncture the skin. Always have cuts or punctures cleaned and treated immediately.
7. Avoid breathing in flux fumes when soldering.
8. Cleaning solvents will dry out the skin. Avoid breathing the vapors.
9. Wash hands before eating or drinking. The lead from the solder remaining on the hands can be ingested with food.

Certain components used on printed circuit boards can be damaged by **static electricity** referred to as **electrostatic discharge (ESD)**. These static charges are created when nonconductive materials, such as plastic from bags or synthetic materi-

als from clothing, are separated. These charges can be induced on a conductor, such as skin, and are delivered in the form of a spark that passes to another conductor. By touching a printed circuit board or semiconductor device a static discharge can be delivered through it that may damage a sensitive component or device.

Most static charges that are able to damage a printed circuit board component or semiconductor device will be too weak to feel—less than 3,000 volts. Most components of printed circuit board assemblies will have warnings printed on them noting that they are sensitive to damage by static electricity, such as the labels shown in Figure 39–26. Keep in mind that just because a component does not have a symbol or label does not mean it is not ESD sensitive.

The following protective guidelines will help to prevent damage to components:

- Keep sensitive components enclosed in antistatic bags, boxes, or wraps when not working on them.
- Remove sensitive components from their protective wrapping only when in the antistatic work area.
- Keep antistatic workstations free of static-generating materials such as Styrofoam, plastic desoldering tools, plastic notebook folders, combs, and so on.

39–7 QUESTIONS

1. Why are safe habits essential when working in the electronics field?
2. What is the primary concern in the field of electronics? ✨
3. How much current through the body will stop a person's breathing?
4. List procedures that should be observed when working with live electricity. ✨

FIGURE 39–26

Warning labels for components sensitive to static electricity.



5. What should be the concern when working around chemicals?
6. List safety guidelines to follow when soldering.
7. List protective measures to prevent ESD damage to components in the work environment.

39–8 ELECTROSTATIC DISCHARGE

Static electricity is created when two substances are rubbed together or separated. The substances can be solid or fluid. The rubbing or separating causes the transfer of electrons from one substance to the other. This results in one substance being positively

charged and the other substance being negatively charged. When either substance comes in contact with a conductor, an electrical current flows until it is at the same electrical potential as ground. This is referred to as electrostatic discharge (ESD).

Static electricity is commonly experienced during the winter months when the environment is dry. Synthetics, especially plastic, are excellent generators of static electricity. When walking across a vinyl or carpeted floor and touching a metal doorknob or other conductor, an electrical arc to ground may result and a slight shock is felt. For a person to feel a shock, the electrostatic po-

tential must be 3,500 to 4,000 volts. It typically takes 5,000 volts to jump 1/4 of an inch. Lesser voltages are not apparent to a person's nervous system even though they are present.

Inside an integrated circuit, a static discharge can destroy oxide layers or junctions. These static discharges can cause an ESD latent defect. The device may appear to operate properly, but it is damaged. It has been weakened and failure will result at a later time. There is no method for testing for ESD latent defect.

Figure 39–27 shows potential sources for generating an electrostatic discharge. Figure 39–28

FIGURE 39–27

Potential electrostatic sources.

OBJECT/PROCESS	MATERIAL/ACTIVITY
Clothes	<ul style="list-style-type: none"> • Synthetic garments • Nonconductive shoes • Virgin cotton at low humidity levels
Chairs	<ul style="list-style-type: none"> • Finished wood • Vinyl • Fiberglass
Floors	<ul style="list-style-type: none"> • Sealed concrete • Waxed finished wood • Vinyl tile or sheeting
Work Surface	<ul style="list-style-type: none"> • Waxed, painted, or varnished surfaces • Vinyl or plastic
Work Area	<ul style="list-style-type: none"> • Spray cleaners • Plastic solder suckers • Soldering iron with ungrounded tip • Solvent brushes with synthetic bristles • Heat guns
Personal Items	<ul style="list-style-type: none"> • Styrofoam or plastic drinking cups • Plastic/rubber hair combs or brushes • Cellophane or plastic candy/gum wrappers • Vinyl purses
Packing and Handling	<ul style="list-style-type: none"> • Regular plastic bags, wraps, envelopes • Bubble wrap or foam packing material • Plastic trays, tote boxes, parts bin

FIGURE 39–28

Electrostatic charges in the work environment.

PROCESS	RELATIVE HUMIDITY	
	LOW (10–20%)	HIGH (65–90%)
Walking on carpet	35,000 V	1,500 V
Walking on vinyl floor	12,000 V	250 V
Working at workbench	6,000 V	100 V
Work stool padded with urethane foam	18,000 V	1,500 V
Plastic bag picked up from bench	20,000 V	1,200 V
Opening vinyl envelope used for instructions	7,000 V	600 V

FIGURE 39–29

Semiconductor devices that can be damaged by electrostatic discharge.

DEVICE TYPE	SENSITIVITY (VOLTS)
Bipolar transistors	380–7000
CMOS	250–2000
ECL	500
JFET	140–10,000
MOSFET	100–200
Schottky diodes, TTL	300–2500
SCR	680–1000

shows typical measured electrostatic charges in a work environment. Figure 39–29 shows a list of electronic parts that may be damaged by sensitivity to electrostatic discharge.

Antistatic workstations (Figure 39–30) are designed to provide a ground path for static charges that could damage a component. They have a conductive or antistatic work surface that is connected to both a ground and the worker's skin through a wrist strap. The wrist strap has a minimum of 500 k Ω resistance to prevent shock in case of contact with a live circuit. When direct grounding is impractical, an ionized air blower is required.

The following list identifies precautions required to minimize electrostatic discharge:

1. Prior to starting work on sensitive electronic equipment or circuits, the electronics technician should be grounded using a wrist strap to discharge any static electric charge built up on the body.
2. Always check manuals and package materials for ESD warnings and instructions.
3. Always discharge the package of an ESD-sensitive device prior to removing it. Keep the package grounded until the device is placed in the circuit.
4. Minimize the handling of ESD devices. Handle an ESD device only when ready to place it in the circuit.
5. When handling an ESD device, minimize physical movement such as scuffing feet.
6. When removing and replacing an ESD device, avoid touching the component leads.
7. Do not permit an ESD device to come in contact with clothing or other ungrounded materials that could have an electrostatic discharge.
8. Prior to touching an ESD device, always touch the surface on which it rests for a minimum of one second to provide a discharge path.
9. When working on a circuit containing an ESD device, do not touch any material that will create a static charge.
10. Use a soldering iron with the tip grounded. Do not use plastic solder suckers with ESD devices.

11. Ground the leads of test equipment momentarily before energizing the test equipment and before probing an ESD device.

39-8 QUESTIONS

1. How is an electrostatic charge generated?
2. What voltage discharge potential can be felt by humans?
3. What is meant by ESD latent defect?
4. An electronics technician who is working on ESD-sensitive devices would prepare by doing what first?
5. Is it safe to remove an ESD device prior to starting to work on a circuit?

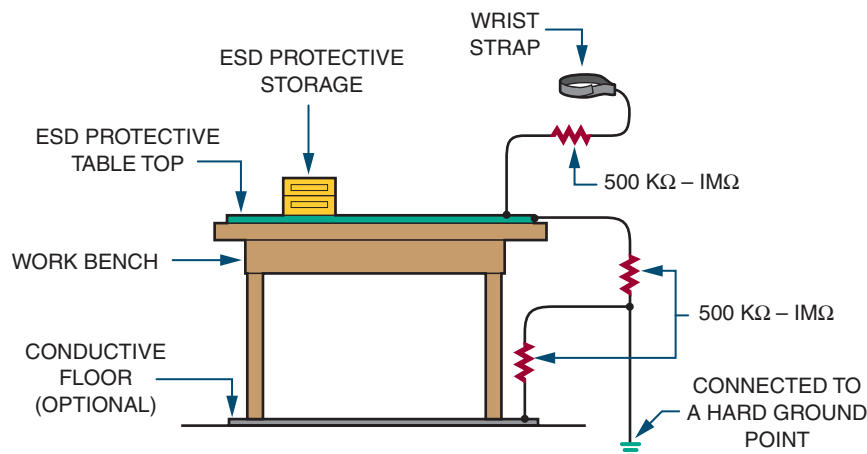
SUMMARY

- A toolbox for working on a printed circuit board should contain the following tools:
 - Plastic and orangewood spudgers
 - Bristle and acid brushes
 - Wire strippers

- Surgical scissors
- X-Acto knife
- Tweezers
- Flat nose pliers (duckbill)
- Needle nose pliers
- Round nose pliers
- Diagonal cutters (flush)
- 1/16" and 1/8" chisel tip for soldering iron
- Heat sinks
- Alcohol and flux bottle
- Soldering iron
- Solder wick
- Manual desoldering tool
- A printed circuit board holding device is useful for holding a printed circuit board.
- An illuminated magnifier helps to detect improper connections or defects on a printed circuit board.
- Leads of resistors and ICs can be shaped with lead-forming tools.
- Test equipment is used by an electronics technician to determine proper operation of a circuit, align components, or troubleshoot.
- An isolate power supply is essential to prevent a lethal shock potential.

FIGURE 39-30

Antistatic work station.



- The multimeter is the first piece of test equipment used to analyze a circuit.
- The voltmeter should have a sensitivity of 20,000 ohms per volt.
- The ohmmeter should not pass more than 1 milliampere of current.
- An oscilloscope is useful for detecting defects in a circuit.
- 10X oscilloscope probes multiply the voltage setting by ten.
- Frequency counters are used for measuring the frequency and period of a recurring signal.
- Signal generators are used to test and align radio transmitters, receivers, and amplifiers.
- Signal generators are classified as audio generator, video signal generator, radio-frequency (RF) generators, frequency modulated RF generators, and special.
- A function generator is a type of signal generator.
- Function generators produce sine, triangular, and square waveforms.
- A logic probe provides a visual indication of what is occurring in a digital circuit.
- A logic probe can sense a high, low, clock, or lack of a signal.
- A logic pulser injects a logic level into a circuit for detection by the logic probe.
- The soldering iron is the primary tool for installing, removing, and replacing components on a printed circuit board.
- Soldering guns should not be used on printed circuit boards.
- A 25–35 W soldering iron is recommended for printed circuit board work.
- The pencil soldering iron is the least expensive type of iron.
- A temperature-controlled soldering station accurately maintains the tip temperature when soldering.
- Iron-clad tips are the best selection for soldering on a printed circuit board.
- A bevel tip is best for general printed circuit board work.
- Tinning is the process of applying solder to the soldering iron tip.
- Idling refers to placing a soldering iron in a stand to remove excess heat.
- Use a systematic method for installing components on a printed circuit board, such as installing all resistors first, then capacitors, then ICs, and so on.
- Use leg warmers on LEDs and small transistors to avoid overheating.
- There is no standard color code for wiring discrete components to a printed circuit board.
- The basic goal of soldering is to electrically and mechanically join circuit components to the printed circuit board.
- In electrical soldering, an alloy mix of 60% tin and 40% lead (60/40) or 63% tin and 37% lead (63/37) is used.
- Soldering surface mounted devices requires a solder with 62% tin, 28% lead, and 2% silver (62/36/2).
- Flux helps the solder alloy flow around the connections by cleaning the component leads of oxide and film, allowing the solder to adhere.
- A pencil soldering iron is the primary tool used in hand soldering.
- A properly soldered connection will be bright and shiny.
- Soldering on a printed circuit board requires careful attention. Too much heat with too much pressure can cause a pad to lift from the board substrate.
- During the soldering process a flux residue forms on the printed circuit board. Flux should be removed because it is sticky and foreign particles can attach to it.
- Desoldering requires special tools and materials to make the task easier.
- In desoldering the first step is to apply more solder.
- SMT components are much smaller and must be handled with tweezers with the

- board mounted in a vise to be worked on with the help of a magnifying glass.
- The surface of a properly soldered connection should be smooth, well feathered at the edges, and bright and shiny with a slight concave configuration.
 - Conformal coatings are nonconductive materials applied in a thin layer on printed circuit boards to provide environmental and mechanical protection.
 - Conformal coatings protect electronic printed circuit boards from abrasion, corrosion, dust, fungus, moisture, and environmental stresses.
 - Safe work habits are required to succeed in the electronics field.
 - A primary concern in the field of electronics is electrical shock.
 - One to 20 milliamperes can cause a painful sensation, with breathing stopped at approximately 20 to 30 milliamperes and electrocution above 100 milliamperes.
 - When handling toxic and hazardous chemicals, know the best protection and first-aid procedures.
 - Components on printed circuit boards can be damaged by static electricity referred to as electrostatic discharge (ESD).
 - Antistatic workstations are designed to provide a ground path for static charges that could damage a component.
 - Static electricity is created when two substances are rubbed together.
 - When a charged substance discharges through a conductor, an electric current flows to ground potential and is referred to as electrostatic discharge (ESD).
 - A dry environment promotes static electricity.
 - Synthetics are excellent generators of static electricity.
 - A person can feel a shock from an electrostatic discharge of 3,500 to 4,000 volts.
 - An ESD latent discharge will result in a device working properly but failing later.
 - An electronics technician should be grounded to discharge static electricity buildup on the body prior to working on a sensitive electronic circuit.
 - Keep the ESD-sensitive device in its package prior to installing it in a circuit.
 - Avoid touching the component leads when installing an ESD-sensitive device in a circuit.
 - Do not touch any material that will create a static charge when working on a circuit containing an ESD device.

CHAPTER 39 SELF-TEST

1. Using the tools identified in an electronics technician toolbox, what tools would be used to remove an IC from a printed circuit board?
2. What pieces of test equipment would be used to test an amplifier circuit on a printed circuit board?
3. Which would be better for soldering a double-pole double-throw switch to a printed circuit board, a temperature-controlled soldering station or a cordless soldering iron?
4. What type tip would be used for the soldering iron in question 3?
5. Explain the procedure for idling a soldering iron.
6. Draw a picture and label all components of an ESD workstation.
7. Develop a set of personal guidelines for handling ESD-sensitive materials.

Basic Troubleshooting

After completing this chapter, the student will be able to:

- Develop common troubleshooting techniques.
- Identify the effects of a short in a circuit.
- Identify the effects of an open in a circuit.
- Describe the effects of aging on component tolerances in a circuit.
- Discuss why documents should be kept for a circuit.

Troubleshooting is the logical process of isolating a defective component in an electrical circuit. This chapter discusses troubleshooting techniques to effectively isolate a defective component in a circuit. The techniques apply to analog series, parallel, and series-parallel circuits as well as complex digital circuits.

40-1 TOOLS FOR TROUBLESHOOTING

An electronics technician needs to know the circuit details for effective troubleshooting. When troubleshooting a circuit, only make a measurement when the normal value is known. A schematic diagram will help to minimize the number of measurements made.

An ohmmeter (Figure 40-1) is useful in troubleshooting for determining an open circuit with an infinite resistance or a short circuit with zero resistance. When using the ohmmeter for measuring individual component resistance in a cir-

cuit, one lead from the component must be removed from the circuit for an accurate reading.

A voltmeter (Figure 40-2) is useful for measuring the voltage drop across a component without removing it from the circuit. Due to the loading effect of a voltmeter because it is inserted in parallel across the component, the voltage reading may be in error. The loading resistance of a voltmeter should be $20\text{ M}\Omega/\text{volt}$ to minimize the loading effect.

An ammeter (Figure 40-3) measures the current flow for the entire circuit or the flow through individual components. The ammeter must be inserted in the circuit in series and will require the removal of one lead of a component from the

FIGURE 40-1

Ohmmeter.

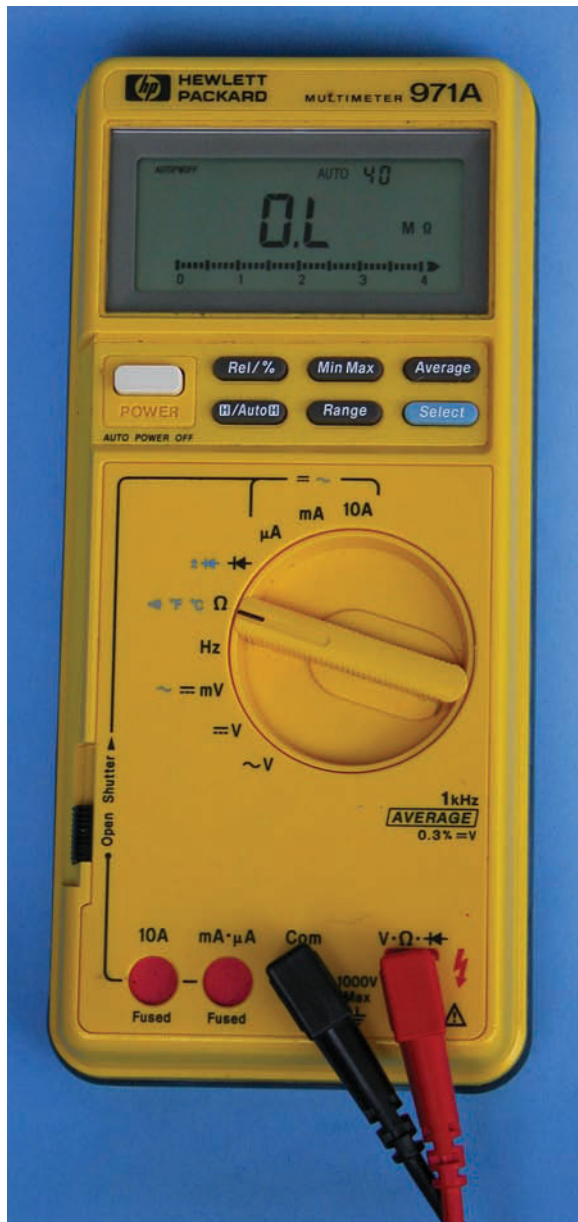


FIGURE 40-2

Voltmeter.



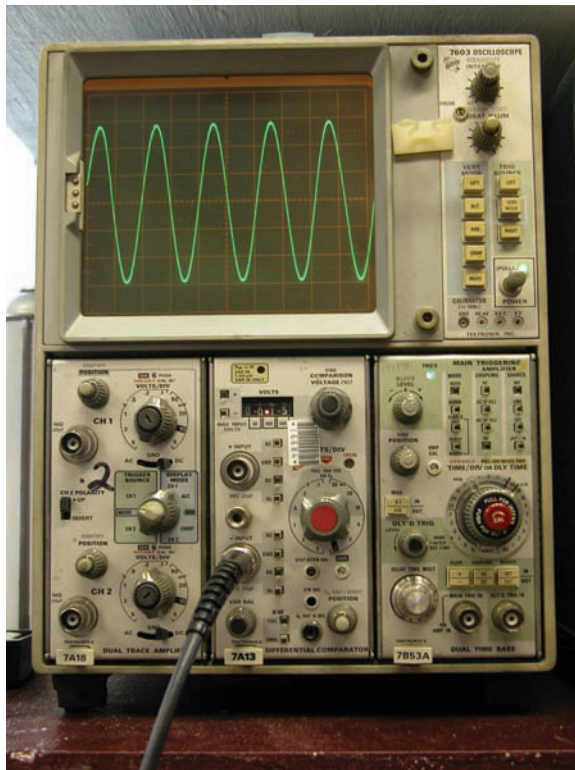
FIGURE 40-3

Ammeter.



FIGURE 40-4

Oscilloscope.



circuit. The ammeter is not the first piece of equipment to use in troubleshooting unless measuring the total current flow of the circuit.

Though many problems can be located using just a multimeter, an oscilloscope (Figure 40-4) is essential for advanced troubleshooting. The basic oscilloscope requirement is a dual trace, 10–20 MHz minimum vertical bandwidth—a delayed sweep is desirable but not essential. A good set of proper 10X/1X probes is also necessary. A storage scope or digital scope might be desirable for certain tasks but is not essential for basic troubleshooting.

An isolation transformer (Figure 40-5) isolates the circuit that does not use a transformer for its power supply. If the circuit is not isolated from the AC line, it can become a shock hazard.

FIGURE 40-5

Isolation transformer.



A soldering iron, solder, and desoldering tools (Figure 40-6) are necessary for removing and replacing components in a printed circuit board.

Prior to starting to troubleshoot an electronic circuit, a good wiring diagram of the circuit is required. There are two types of wiring diagrams, a block diagram (Figure 40-7a) and a schematic diagram (Figure 40-7b). A block diagram lays out the components of the system and how they relate to each other. It helps to gain an understanding of the basic system and how it works. A schematic diagram provides more detail than the block diagram by showing the individual components of a

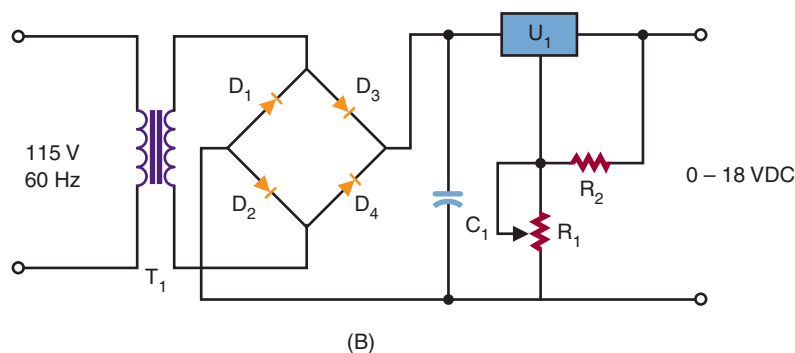
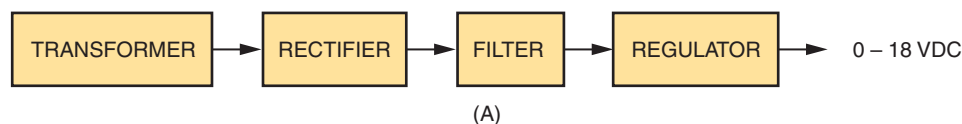
FIGURE 40-6

Tools for successful repairing of a printed circuit board.



FIGURE 40-7

Types of wiring diagrams.



circuit using schematic symbols and how they are interconnected in a circuit.

40-1 QUESTIONS

1. What pieces of equipment are used for taking measurements when troubleshooting?
2. What must be done when measuring resistance and current in a circuit?
3. What precaution must be taken when using a voltmeter for troubleshooting?
4. What is an oscilloscope used for in troubleshooting?
5. Why is an isolation transformer essential to troubleshooting?
6. What function does a schematic diagram serve in troubleshooting?

40-2

ISOLATION TECHNIQUES FOR EFFECTIVE TROUBLESHOOTING

Effective troubleshooting is a step-by-step process, which requires an electronics technician to work through four steps to verify, isolate, and eliminate problems in a circuit.

Step one in locating a problem for a malfunctioning circuit or a recently assembled printed circuit board is to manually check the printed circuit board over thoroughly before power is applied. Check the circuit for construction errors. The two types of construction errors are: improper component placement and wiring errors for discrete components. Discrete components are components not mounted on the printed circuit board.

Component placement errors include: wrong component or component not in the correct location, components mounted in backwards, or

multi-lead components with leads inserted improperly. Wiring errors include: a wire installed in the wrong location, a wire missing, a wire that is broken (open), and a wire that is installed with a faulty solder connection.

Step two requires applying power to the circuit to determine if an electrical problem exists. Depending on the type of circuit, indicators will light, sound will emit, etc. If the circuit appears to perform properly, let the circuit warm up and settle in its normal operating mode. The purpose is to determine if anything is defective with the circuit. If the circuit appears to be operating properly then it can be calibrated/adjusted if required and then move on to step four.

Step three is to troubleshoot the circuit to find out what is wrong with the circuit that it will not work properly, then determine what has to be done. Electronic technicians use their *eyesight* to look for trouble. If a component receives excess current, it may split open or char. Technicians also *smell* for burnt insulations from components that receive excess current such as transformers, coils, or components with insulated leads. They *listen* for sounds such as a snap, crackle, or pop that indicate loose wires, bridged connections, or frying components. They *touch* components to determine if they are running hot or cold. Electronic technician's senses of sight, smell, hearing, and touch is only a beginning. To solve more difficult problems, meters and oscilloscopes are used once the problem is located in a specific part of the circuit. Use this data to isolate and repair the defect(s).

Step four is to determine if the circuit will work when it is exposed to the environment it is designed to operate in.

40-2 QUESTIONS

1. What are the four steps for effective troubleshooting?
2. What should be looked for when visually inspecting an assembled board?

3. What is the function of step two in the troubleshooting process?
4. How do electronics technicians use their senses for troubleshooting?
5. What is the function of step four in the troubleshooting process?

40-3 COMMON TYPES OF DEFECTS

Figure 40-8 shows a chart indicating common types of defects during printed circuit board assembly. The chart indicates that the most common type of defect is open and short circuits. An open circuit has an infinite resistance. An open in a circuit may not have infinite ohms but the resistance will be so high relative to the other circuit resistances that it can be assumed to be infinite. When measuring voltage with a voltmeter, connect the negative side of the voltmeter to ground. Probe various test points with the positive lead. If the open circuit is between a monitored point and ground, the voltmeter will read the full supply voltage; otherwise the voltmeter will read zero (Figure 40-9).

A short circuit has zero ohms resistance. In reality, the short may not be zero ohms, but is lower than what should be measured and is assumed to be zero resistance. A *short circuit* is the term used to identify an unintended connection or a defective component with zero ohms resistance. When measuring voltage across a shorted component, the voltage will read zero volts. When measuring the resistance of a shorted component, the resistance will be zero ohms. Shorts in power equipment are dangerous because they can result in electrical fires due to a high current flow, especially if the circuit is not fused (Figure 40-10).

When taking measurements in a circuit, check the measured values against known values.

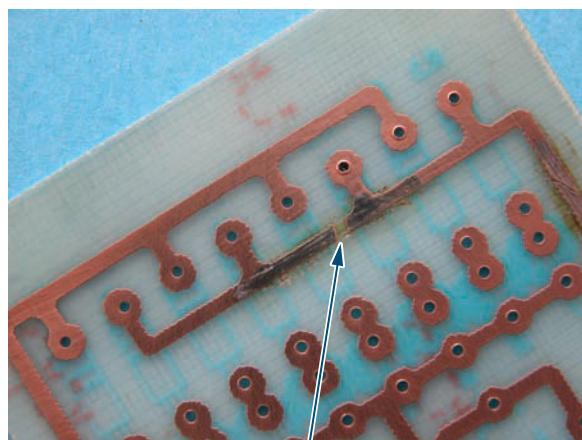
FIGURE 40-8

Common defects of printed circuit board assembly.

PCB ASSEMBLY DEFECTS	PERCENTAGE
Open	34
Short, solder bridges	15
Missing parts	15
Misoriented parts	9
Marginal solder connection	9
Solder balls, voids	7
Bad components	7
Wrong components	7

FIGURE 40-9

Open on a printed circuit board.



OPEN

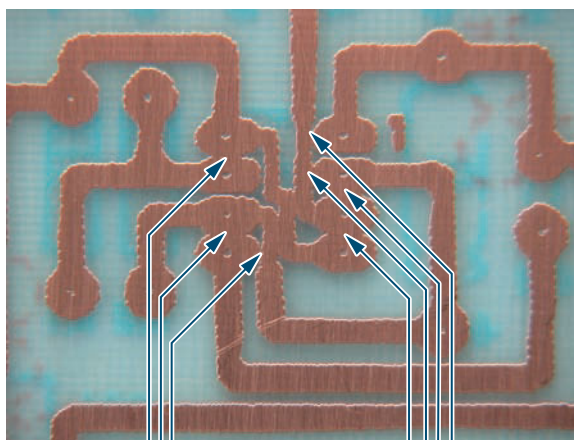
Make a chart and record any measurements taken as shown in Figure 40-11.

Resistors may increase or decrease in value through age or circuit defects. If a resistor increases in resistance, the results will be similar to that of an open circuit. If a resistor decreases in resistance, the results will be similar to that of a short circuit.

Traces on a printed circuit board can also develop defects. If a trace becomes shorted to another trace through soldering, the circuit may not work or components may be damaged—or worse, the board may catch fire. If a trace opens it acts

FIGURE 40-10

Shorts on a printed circuit board.



SHORT/BRIDGE

like a resistor that has opened and the circuit will not work or will only partially work.

40-3 QUESTIONS

1. In a series circuit, what is the voltage measured across a shorted resistor?
2. Why are shorts dangerous in a circuit?
3. How is an open in a circuit determined with a voltmeter?

FIGURE 40–11

Project/equipment data recording chart for future referencing.

Project/

Equipment: _____ **Date:** _____

Visual (Check all components for improper placement and orientation, wiring errors, and faulty soldering connections.)
Record all faults located and corrected.

DEFECTIVE COMPONENT	ACTION TAKEN
1.	
2.	
3.	
4.	
5.	

Power-Up (Check circuit/device for proper operation) Record all faults, otherwise perform any calibrations and adjustments.

FAULTS	CALIBRATIONS/ADJUSTMENTS COMPLETED	MEASURED VALUES
1.		
2.		
3.		
4.		
5.		

Troubleshoot (After determining a problem exists, use the appropriated test equipment to identify the fault) Record all faults, otherwise perform any calibrations and adjustments. Waveforms may be attached with proper registration/identification and record any comments.

PROBLEM	VOLTAGE/CURRENT MEASURED	WAVEFORMS	COMMENTS
1.			
2.			
3.			
4.			
5.			

Operation (Run the circuit for an extended period of time to insure no problems occur) Record any problems, otherwise enjoy.

PROBLEM	COMMENTS
1.	
2.	
3.	
4.	
5.	

Operation (Record any comments, thoughts, ideas for future reference)

COMMENTS

4. What happens to resistors in a circuit to cause them to change value?
5. What can happen to traces on a printed circuit board to cause a defect?

40-4 TROUBLESHOOTING TIPS

Never start troubleshooting a circuit with test equipment. Start with the power of observation. A technician's senses and thinking can help to isolate a problem quickly.

Many problems have simple solutions. When troubleshooting, do not immediately assume a problem is complex. It could be a bad connection or a blown fuse. Remember that problems with the most impact usually have the simplest solutions. Difficult problems to solve are those that are intermittent or hard to reproduce.

If a problem is difficult to solve, step away from it for while. Sometimes, just thinking about the problem will lead to a different approach or solution. Never work on a problem when tired because it is both dangerous and nonproductive.

Whenever working on equipment, make notes and diagrams or take photographs for use when it is time to reassemble the unit. Most connectors are keyed against incorrect insertion or interchange of cables, but not all. Apparently identical screws may be of differing lengths or may have slightly different thread types. Little parts may fit in more than one place or orientation. Pill bottles, film canisters, egg cartons, and plastic ice cube trays provide a handy place for sorting and storing screws and other small parts during disassembly.

The workspace should be open, well lit, ESD protected, and situated so that dropped parts can be easily found. The best location should be dust

free and allow suspending troubleshooting without having to place everything in a box for storage.

Take the precautions of touching a ground point first to prevent electrostatic discharge into a component. Components such as MOSFETs and ICs are vulnerable to ESD.

WARNING: When using an isolation transformer, a live chassis should not be considered a safe ground point.

40-4 QUESTIONS

1. What is the first thing to do when troubleshooting a circuit?
2. What types of problems are the most difficult to solve?
3. What should be done when disassembling a piece of equipment?
4. How can parts be stored when disassembling a piece of equipment?
5. Describe the ideal work location for troubleshooting.

40-5 DOCUMENTATION

The most important document when troubleshooting a circuit is the schematic diagram. It allows the electronics technician to read the circuit like a book. It shows not only how the circuit is connected but also voltage drops in a circuit. A good schematic will also show waveforms at various test points in the circuit.

When a circuit is assembled it's a good idea to take a copy of the schematic and record voltages measured for future reference. Also, record any waveforms that will help in future troubleshooting.

The secret of successful troubleshooting is good documentation. Keep all the documents of a circuit together for future reference.

40-5 QUESTIONS

1. What is the most important document for troubleshooting?
2. What function does a schematic diagram serve?
3. What should be done after a circuit is assembled?
4. What is the secret of successful troubleshooting?
5. What should be done after a circuit is assembled and running?

SUMMARY

- Only make measurements when the normal value is known.
- An ohmmeter is useful for detecting opens and shorts.
- When checking the resistance of a component, one lead must be removed from the printed circuit board.
- A voltmeter can measure the voltage drop across a component.
- Voltmeters should have a loading resistance of $20\text{ M}\Omega/\text{volt}$.
- An ammeter can be used to measure individual components or total current flow in a circuit.
- An oscilloscope is useful for detecting the presence or absence of a signal.
- An isolation transformer isolates a circuit from the AC line to prevent electrical shock.
- Schematic diagrams are necessary for troubleshooting a circuit.
- The four steps for effective troubleshooting are:
 1. Check the circuit for construction errors before applying power.
 2. Apply power and check for normal operation.
 3. Troubleshoot using sight, smell, hearing, and touch to isolate the problem to a specific part of the circuit.
 4. Expose the circuit to the environment it is designed to operate in.
- A short circuit has zero ohms resistance.
- An open circuit has an infinite resistance.
- When making measurements in a circuit, check the measured values against known values.
- Resistors may increase or decrease in value through age or circuit defects.
- Traces on a printed circuit board can become shorted to another trace through soldering and may damage the printed circuit board or components.
- Traces may become open through manufacturing and thus not work properly.
- A schematic diagram is the most important document when troubleshooting a circuit.
- Good schematic diagrams will show waveforms at various test points in the circuit.
- When a circuit is assembled it is a good idea to record voltages measured for future reference.
- Never start troubleshooting with test equipment; always start with analytical thinking.
- Problems with the most impact will usually have the simplest solutions.
- Difficult problems to solve include intermittent and hard to reproduce problems.
- If a problem is hard to solve, stepping away to think about it may lead to a different approach or solution.
- The secret of successful troubleshooting is good documentation for future reference.

CHAPTER 40 SELF-TEST

1. What can be used to prevent electrical shock when troubleshooting a circuit?
2. Describe how to troubleshoot a circuit that does not work.
3. How can test equipment effectively be used for troubleshooting?
4. What is the difference between a short circuit and an open circuit?
5. How can a schematic diagram effectively be used for troubleshooting?

SECTION 6 ACTIVITIES—PRACTICAL APPLICATIONS

1. Using the schematic in Figure 8–18 of a real-world voltage divider, lay out a printed circuit board design.
2. Design a printed circuit board for the voltage tripler shown in Figure 27–33. Check the CD for the MultiSim circuit files for component values.
3. Fabricate a printed circuit board from one of the printed circuit board designs developed in activity 1 or 2.
4. Using a printed circuit board from an electronic device that is inoperative, desolder all the components.
5. Take apart an electronic device to determine how it was constructed. Record each step in the disassembly of the device. (Follow proper safety precautions.)
6. Using an assembled circuit board, draw a schematic by following the traces on the circuit board. It is best to start with a single-sided printed circuit board.
7. Take the schematic that was drawn for activity 6 and draw it in MultiSIM or Livewire to determine if the schematic works properly.
8. On an electronic device that does not work, use the steps for troubleshooting to determine why it is inoperative.

GLOSSARY

- Accumulator** The most used register in a micro-processor.
- Active filters** Inductorless filters using ICs.
- Adder** A logic circuit that performs addition of two binary numbers.
- Alphanumeric** Represents characters containing alphabetic letters as well as numbers and symbols.
- Alternating current (AC)** Current that flows in one direction, then in the opposite direction.
- Alternation** The two halves of a cycle.
- Alternator** AC generator.
- Ammeter** A meter used to measure the amount of current flowing in a circuit.
- Ammonium persulphate acid** Mild acid used to etch printed circuit boards. Highly toxic.
- Ampere** Measure of current flow.
- Ampere-hour** A rating used to determine how well a battery delivers power.
- Amplification** Providing an output signal that is larger than the input.
- Amplitude** The maximum value of a sine wave or a harmonic in a complex waveform measured from zero.
- Analog meter** A meter that uses a graduated scale with a pointer.
- AND** Logic multiplication.
- AND gate** Performs the basic logic operation of multiplication.
- Aperture file** Specifies the physical size of a printed circuit board in Gerber format.
- Apparent power** Obtained by multiplying the source voltage and current and measured in units of volt-amps.
- Arithmetic instructions** Allow the microprocessor to compute and manipulate data.
- Arithmetic logic unit (ALU)** Performs math logic and decision-making operations in the computer.
- Armature** The moving portion of a magnetic circuit.
- Artificial magnet** Magnet created by rubbing a piece of soft iron against another magnet.
- ASCII Code** American Standard Code for Information Interchange.
- Astable multivibrator** A free-running multivibrator.
- Asynchronous** Not occurring at the same time.
- Atom** Smallest basic unit of matter.
- Atomic number** The number of protons in the nucleus of an atom.
- Atomic weight** The mass of an atom (the number of protons and neutrons).
- Audio amplifier** Amplifies AC signals in the audio range of 20 to 20,000 hertz.
- Autorouter** A subroutine in a CAD program that automatically routes printed circuit board traces.
- Autotransformer** Used to step the applied voltage up or down without isolation.
- Barrier voltage** Voltage created at the junction of P-type and N-type material when joined together.
- Battery** A combination of two or more cells.
- BCD** See *Binary coded decimal*.
- Bias voltage** The external voltage applied across the PN junction of a device.
- Binary coded decimal (BCD)** A code of four binary digits to represent decimal numbers 0 through 9.
- Binary number system** A base 2 number system with two digits, 0 and 1.
- Bipolar transistor** A semiconductor device capable of amplifying voltage or power.
- Bistable action** Refers to locking onto one of two stable states.
- Bistable multivibrator** A multivibrator with two stable states.
- Bit** A term derived from the words *binary digit*.
- Block diagram** A simplified outline of an electronic system in which circuits or parts are shown as rectangles.

- Bode plotter** A computer simulation tool that measures a signal's voltage gain or phase shift.
- Breadboarding** The process of constructing a temporary circuit for testing and/or modifying a circuit design.
- Break over** The point at which conduction starts to occur.
- Bridge rectifier** Operates both half cycles with full voltage out.
- Bridging** Occurs when two traces in close proximity touch or when too much solder is used on a connection and solder flows to another pad or trace.
- CAD** *See* Computer-aided design.
- Capacitance** The ability of a device to store energy in an electrostatic field.
- Capacitive reactance** Opposition a capacitor offers to applied AC voltage.
- Capacitor** A device that possesses capacitance.
- Cell** Method of producing electrical energy consisting of two dissimilar metals, copper and zinc, immersed in a salt, acid, or alkaline solution.
- Channel** The U-shaped region of a JFET.
- Chemical cell** A cell used to convert chemical energy into electrical energy.
- Chip** An integrated circuit. It derives from the fact that an integrated circuit is manufactured from a single chip of silicon crystal.
- Circuit breaker** A device that performs the same function as a fuse but does not have to be replaced.
- Clamping circuit** Circuit used to clamp the top or bottom of a waveform to a DC level.
- Class A amplifier** Amplifier biased so that current flows throughout entire cycle.
- Class AB amplifier** Amplifier biased so that current flows for less than full but more than half cycle.
- Class B amplifier** Amplifier biased so that current flows for only one-half of input cycle.
- Class C amplifier** Amplifier biased so that current flows for less than half of the input cycle.
- Clipping circuit** A circuit used to square off the peaks of an applied signal.
- Clocked flip-flop** A flip-flop that has a third input called the clock or trigger.
- Closed circuit** A complete path for current flow.
- Closed-loop mode** An op-amp circuit that uses feedback.
- CMOS** Complementary metal oxide semiconductor. A family of integrated circuits noted for low power consumption.
- CNC** *See* Computer numerical control machine.
- Cold solder connection** Occurs when the soldering iron is withdrawn too soon.
- Color code** A system developed to place large numerical values on small components. Used with resistors and capacitors.
- Common-base circuit** Circuit in which the base is common to both the input and output circuit.
- Common-collector circuit** Circuit in which the collector is common to both the input and output circuit.
- Common-emitter circuit** Circuit in which the emitter is common to both the input and output circuit.
- Comparator** A logic circuit used to compare the magnitude of two binary numbers.
- Compare instructions** Compare data in the accumulator with data from a memory location or another register.
- Component side** The side of a printed circuit board where the components are placed.
- Compound** Combination of two or more elements.
- Computer-aided design (CAD)** A computer program used to assist in the design of a product/object.
- Computer numerical control (CNC) machine** A milling machine that is controlled by a computer and is useful in the removal of copper to form a printed circuit board.
- Condition-code register** A register that keeps track of the status of the microprocessor.
- Conductance** The ability of a material to pass electrons.
- Conductor** A material that contains a large number of free electrons.
- Conformal coating** A nonconductive material applied to an assembled printed circuit board to provide environmental and mechanical protection.
- Continuity test** A test for an open, short, or closed circuit using an ohmmeter.

- Control unit** Decodes each instruction as it enters the computer.
- Coulomb** Unit of electrical charge (represents 6.24×10^{18} electrons).
- Counter** A logic circuit that can count a sequence of numbers.
- Coupling** Joining of two amplifier circuits together.
- Covalent bonding** The process of sharing valence electrons.
- Current** Slow drift of electrons.
- Cycle** Two complete alternations of current with no reference to time.
- D flip-flop** A flip-flop that has only a single data input and a clock input.
- DC amplifier** See Direct-coupled amplifier.
- Data movement instructions** Move data from one location to another within the microprocessor and memory.
- Decade counter** A counter with a modulus of ten.
- Decimal-to-binary encoder** Converts a single decimal digit (0–9) to a 4-bit binary code.
- Decimal-to-binary priority encoder** Produces a binary output based on the highest decimal on the input.
- Decoder** Processes complex binary codes into recognizable characters.
- Defluxer** A chemical substance that is used to dissolve flux to aid in its removal from a printed circuit board.
- Degenerative feedback** A method of feeding back a portion of a signal to decrease amplification.
- Degree of rotation** The angle to which the armature has turned.
- Depletion mode** A mode in which electrons are conducting until they are depleted by the gate bias voltage in a MOSFET.
- Depletion MOSFET** A device that conducts when zero bias is applied to gate.
- Depletion region** Region near the junction of N-type and P-type material.
- Desoldering** The removal of solder from a component lead and printed circuit board pad to aid in the removal of a component that has been soldered to a printed circuit board.
- Desoldering bulb** Uses a rubber bulb to create a vacuum to suck up molten solder. Used with a soldering iron.
- Desoldering pump** Uses a spring-loaded plunger to create a vacuum to suck up molten solder. Used with a soldering iron.
- Desoldering wick** Uses a copper braid with flux to create a capillary action to pull up molten solder. Used with a soldering iron.
- DIAC** Acronym for *Diode AC*, a bidirectional triggering diode.
- Difference amplifier** Amplifier that subtracts one signal from another signal.
- Difference of potential** The force that moves electrons in a conductor.
- Differential amplifier** Amplifier with two separate inputs and one or two outputs.
- Differentiator** A circuit used to produce a pip or peak waveform from a square wave.
- Digital computer** A device that automatically processes data using digital techniques.
- Digital meter** A meter that provides a readout in numerals.
- Diode** A semiconductor device that allows current to flow only one way.
- DIP (dual in-line package)** An integrated circuit package that has a row of pins for through-hole mounting along each of its longer sides.
- Direct-coupled amplifier** Provides amplification of low frequencies to DC voltage.
- Direct current (DC)** Current that flows in only one direction.
- Discrete component** A component that is not attached directly to the printed circuit board. Discrete components are connected to the printed circuit board using wire.
- Disturbed connection** The result of movement of the component lead or wire before the solder sets.
- DMM** Digital multimeter.
- Doping** The process of adding impurities to semiconductor material.
- Double-sided printed circuit board** A printed circuit board with copper traces and pads on both sides.
- DRAM (dynamic RAM)** Read/write memory that must be refreshed (read or written into) periodically to maintain the storage of information.

- Drill file** Informs the printed circuit board manufacturer where the holes are located and what size the holes are.
- Dual in-line package (DIP)** Standard package for integrated circuits.
- Duty cycle** Ratio of the pulse width to the period.
- Effective value** Value of AC current that will produce same amount of heat as DC current.
- Electrical shock** The passing of electricity through the body with enough current to be felt.
- Electromagnet** Magnet created by passing a current through a coil of wire.
- Electromagnetic induction** Inducing a voltage from one coil into another coil.
- Electromotive force (emf)** Another name for difference of potential.
- Electron** Negative charge in orbit around the nucleus of an atom.
- Electronics technician** An individual who builds, installs, tests, and repairs electronic devices.
- Electrostatic discharge (ESD)** The discharge of static electricity from an object to an object with a lesser charge. May be fatal to sensitive electronic components.
- Element** Basic building block of nature.
- ELI** The AC current lags the voltage by 90 degrees in an inductor (acronym).
- Emitter follower** Another name for a common emitter amplifier because the emitter voltage follows the base voltage.
- Encoder** A logic circuit of one or more inputs that generates a binary output.
- Enhancement mode** A mode in which electron flow is normally cut off until it is aided or enhanced by the bias voltage on the gate of a MOSFET.
- Enhancement MOSFET** A device that only conducts when a bias is applied to the gate.
- ESD** See Electrostatic discharge.
- Exclusive NOR gate (XNOR)** Produces a high output only when both inputs are high.
- Exclusive OR gate (XOR)** Produces a low output only when both inputs are high.
- Fall time** Time it takes for a pulse to fall from 90% to 10% of maximum amplitude.
- Farad** The basic unit of capacitance.
- Faraday's law** The basic law of electromagnetism. The induced voltage in a conductor is directly proportional to the rate at which the conductor cuts the magnetic lines of force.
- Ferric chloride acid** A mild acid used to remove unwanted copper during the printed circuit board fabrication process.
- Filter** Converts pulsating DC voltage to a smooth DC voltage.
- Fixed capacitor** A capacitor having a definite value that cannot be changed.
- Flat response** Indicates that the gain of an amplifier varies only slightly within a stated frequency range.
- Flip-flop** A bistable multivibrator whose output is either a high or a low. See Bistable multivibrator.
- Flux** A material used to remove oxide films from metallic surfaces. May be a liquid, paste, or located in the center of solder.
- Flux cleaner** A chemical cleaner used to remove flux residue from a soldered connection.
- Forward bias** When the current flows in the forward direction.
- Fractured connection** See Disturbed connection.
- Free-running** Does not require an external trigger to keep running.
- Frequency** Number of cycles that occur in a specific period of time.
- Frequency compensation** An internal network that does not require external components.
- Frequency counter** Measures frequency by comparing against known frequency.
- Frequency domain concept** All periodic waveforms are made of sine waves.
- Full adder** An adder circuit that takes into account a carry.
- Full scale value** The maximum value indicated by a meter.
- Full subtractor** A subtractor that takes into account the borrow input.
- Full-wave rectifier** Operates during both half cycles with half the output voltage.
- Function generator** A signal generator that is capable of producing fundamental waveforms such as sine, triangular, and rectangular or square.

- Fundamental frequency** Represents the repetition rate of the waveform.
- Fuse** A device designed to fail if an overload occurs.
- Generator** A device used to generate electricity by means of a magnetic field.
- Gerber file** A standard printed circuit board format that is supported by all layout software.
- Germanium** A gray-white element recovered from the ash of certain types of coal.
- Ground** The common point in electrical/electronic circuits.
- Ground plane** An entire printed circuit board layer that is isolated from connections and connected to ground potential.
- Grounding** The process of making a connection to ground potential.
- Half adder** An adder circuit that does not take into account any carries.
- Half subtractor** A subtractor that does not take into account any borrow input.
- Half-wave rectifier** Operates only during one-half of the input cycle.
- Hand drawn** The simplest technique to transfer a design to a printed circuit board. Uses a resist pen or permanent marker.
- Harmonics** Multiples of the fundamental frequency.
- Henry** The unit of inductance.
- Hertz** Cycles per second, the unit of frequency.
- High-pass filter** Filter that passes high frequencies and attenuates low frequencies.
- Hole** The absence of an electron.
- IC (integrated circuit)** A device in which all of the components of an electronic circuit are fabricated on a single piece of semiconductor material, often called a chip, which is placed in a plastic or metal package with terminals for external connections.
- ICE** The AC current leads the voltage by 90 degrees in a capacitor (acronym).
- IF amplifier** See Intermediate frequency amplifier.
- Impedance** Opposition to current flow in an AC circuit.
- Inductance** The property of a coil that prevents changes in current flow.
- Induction** The effect one body has on another body without physical contact.
- Inductive reactance** Opposition offered by an inductor in an AC circuit to current flow.
- Inductor** A device designed to have a specific inductance.
- In phase** When two signals change polarity at the same time.
- Input/output (I/O)** Allows the computer to accept and produce data.
- Input/output instructions** Control I/O devices.
- Insulator** A material that has few free electrons.
- Integrated circuit (IC)** A complete electronic circuit in a small package.
- Integrator** A circuit used to reshape a waveform.
- Intermediate frequency amplifier** A single-frequency amplifier.
- Intrinsic material** Pure material.
- Inverter** A logic circuit that changes its input to the opposite state for an output.
- Ionization** The process of gaining or losing electrons.
- Isolate power supply** A power supply that is isolated from ground.
- Isolation transformer** Used to prevent electrical shocks; isolates the circuit being worked on from the main circuit.
- JK flip-flop** A flip-flop that incorporates all the features of other flip-flops.
- Jumper** A piece of wire used to make an electrical connection between two points on a single-sided printed circuit board.
- Junction FET (JFET)** Field effect transistor that can provide amplification.
- Junction transistor** See bipolar transistor.
- Karnaugh map** A technique for reducing complex Boolean expressions that was developed by Maurice Karnaugh.
- Kirchoff's current law** The algebraic sum of all the currents entering and leaving a junction is equal to zero.
- Kirchoff's voltage law** The algebraic sum of all the voltages around a closed circuit equals zero.
- Latch** Lock onto.
- Lead** A connecting wire, such as a test lead, battery lead, and so forth.

- Leading edge** The front edge of a waveform.
- Leg warmer** Small pieces of insulation that are placed on leads of heat-sensitive components to prevent overheating when soldering.
- Light** Electromagnetic radiation that is visible to the human eye.
- Light-emitting diode (LED)** Converts electrical energy directly into light energy.
- Limiting circuit** See Clipping circuit.
- Load** A device or circuit on which work is performed.
- Loading down** A load is placed on the output which affects the amount of output current.
- Logic instructions** Instructions that contain one or more of the Boolean operators (AND, OR, and exclusive OR).
- Logic probe** A digital instrument that can detect a high or low level or a group of pulses at a point in a digital circuit.
- Logic pulser** A device that can inject a digital signal into a digital circuit for troubleshooting.
- Loudspeaker** A device for converting audio frequency current into sound waves.
- Low-pass filter** Filter that passes low frequencies and attenuates high frequencies.
- LSB** Least significant bit.
- Magnet** A piece of iron or steel that attracts other pieces of iron or steel.
- Magnetic field** The region around a magnet.
- Magnetic induction** The effect a magnet has on an object without physical contact.
- Magnetism** The property of a magnet.
- Material safety data sheet (MSDS)** A document supplied when a chemical is purchased or acquired that contains a hazardous substance.
- Matter** Anything that occupies space.
- Memory** Stores the program and data for operation by the computer.
- Mho** Unit of conductance.
- Microampere** One-millionth of an ampere.
- Microcontroller** A single-chip computer designed for machine-control applications.
- Microphone** An energy converter that changes sound energy into corresponding electrical energy.
- Microprocessor** Contains ALU, timing, control, and decoding circuitry for the computer.
- Milliampere** One-thousandth of an ampere.
- Miscellaneous instructions** Instructions used to enable or disable interrupt lines, clear or set flag bits, or allow the microprocessor to perform BCD arithmetic.
- Mixture** Physical combination of elements and compounds.
- Modulus** The maximum number of states in a counting sequence.
- Molecule** Smallest part of a compound that retains the properties of the compound.
- Monostable multivibrator** A multivibrator with only one stable state.
- MOSFET** Metal Oxide Semiconductor Field Effect Transistor.
- MSB** Most significant bit.
- MSDS** See Material safety data sheet.
- Multilayer board** A printed circuit board that is fabricated from two or more printed circuits with traces on one or both sides laminated together.
- Multimeter** A voltmeter, ammeter, and ohmmeter combined into a single meter.
- Multiplexer** Selects and routes one of several inputs to a single output.
- Multivibrator** A relaxation oscillator that has two temporary stable conditions.
- Mutual inductance** An effect resulting when a magnetic field expands in the same direction as the current in the primary, aiding it and causing it to increase.
- NAND gate** A combination of an inverter and an AND gate.
- Negative feedback** Feeding back of output signal to oppose temperature change.
- Negative ion** An atom that has gained one or more electrons.
- Negative temperature coefficient** As temperature increases, resistance decreases.
- Neutron** Electrically neutral particle in the nucleus of an atom.
- Nonsinusoidal oscillators** Oscillators that do not produce a sine wave output.
- NOR gate** A combination of an inverter and an OR gate.

- NOT circuit** Performs the logic function of inversion.
- N-type semiconductor material** Semiconductor material doped with a pentavalent material.
- Nucleus** The center of the atom, which contains the mass of the atom.
- Occupational Safety and Health Administration (OSHA)** A federal organization that defines regulations for chemicals with hazardous substances.
- Ohm** Unit of resistance.
- Ohmmeter** A meter used to measure resistance.
- Ohm's law** The relationship between current, voltage, and resistance.
- One-shot multivibrator** *See* Monostable multivibrator.
- Op-amp** *See* Operational amplifier.
- Open circuit** Has infinite resistance because no current flows through it.
- Open-loop mode** An op-amp circuit that does not use feedback.
- Operational amplifier** A very high-gain DC amplifier.
- Optical coupler** Used to isolate loads from their source.
- OR** Logic addition.
- OR gate** Performs the logic operation of addition.
- Oscillator** A circuit that generates a repetitive AC signal.
- Oscilloscope** Provides a visual display of what occurs in a circuit.
- OSHA** *See* Occupational Safety and Health Administration.
- Out of phase** When two signals are not in phase.
- Overshoot** Occurs when the leading edge of the waveform exceeds the maximum value.
- Over-voltage protection circuit** Protects a load from voltage increases above a predetermined level.
- Pad** Is located on a printed circuit board where connections are made to connect the lead from a component to the trace.
- PAL** Programmable array logic.
- Paper dolls** Two-dimensional representations of circuit components that are the exact size of the base of the components. Used to assist in component placement when laying out a printed circuit board.
- Parallel cells** Cells with all positive and all negative terminals connected together.
- Parallel circuit** Provides two or more paths for current flow.
- Passive filters** Filters that use resistors, inductors, and capacitors.
- PCB** *See* printed circuit board.
- Peak inverse voltage (PIV)** Maximum safe reverse voltage rating.
- Peak-to-peak value** Vertical distance from one peak to the other peak.
- Peak value** Absolute value of point on a waveform at the greatest amplitude.
- Pencil soldering iron** A soldering iron that is held like a pencil.
- Pentavalent** Atoms with five valence electrons.
- Period** Time required to complete one cycle of a sine wave.
- Periodic waveforms** Waveforms that occur at regular intervals.
- Permanent magnet** Magnet that retains its magnetic properties.
- Phase angle** The exact phase shift between the input and the output.
- Phase-shift network** Shifts the phase of the output signal with respect to the input.
- Photo cell** *See* Photoconductive cell.
- Photoconductive cell** Has internal resistance that changes with light intensity.
- Photodiode** Used to control current flow by means of light energy.
- Phototransistor** Works like a photodiode but produces higher output current.
- Photovoltaic cell** A device used to convert light energy into electrical energy.
- Piezoelectric effect** A process that results when pressure is applied to a crystal.
- PIN photodiode** A photodiode with an intrinsic layer between the P and N regions.
- PLA** Programmable logic array
- Plastic quad flat pack** A high density, surface-mount package with leads on all four sides that provide the most variation of any package type.
- PLD** Programmable logic device.
- Positive feedback** Feeding back a part of the output signal that is in phase.

- Positive ion** An atom that has lost one or more electrons.
- Potential** The ability to do work.
- Potentiometer** A variable resistor used to control voltage.
- Power** The rate at which energy is dissipated by the resistance of a circuit.
- Power amplifier** An audio amplifier designed to drive a specific load.
- Power factor** The ratio of true power in watts to apparent power in volt-amps.
- Power plane** An entire printed circuit board layer that is isolated from connections and connected to the voltage potential.
- PQFP** See plastic quad flat pack.
- Primary cell** Chemical cell that cannot be recharged.
- Printed circuit board (PCB)** Consists of an insulating base material on which conductive traces of copper act as interconnecting wires. Traces may be located on one or both sides.
- Program** A list of computer instructions arranged sequentially to solve a problem.
- Program-control instructions** Change the content of the program counter.
- PROM** Programmable read-only memory.
- Program counter** Contains the instruction addresses for a program.
- Proton** Positively charged particle in the nucleus of an atom.
- P-type semiconductor material** Semiconductor material doped with a trivalent material.
- Pulse width** The duration the voltage is at its maximum or peak value until it drops to its minimum value.
- Radio-frequency amplifiers** Amplify signals of 10,000 hertz to 30,000 megahertz.
- Rectification** The process of converting AC to DC.
- Rectifier circuit** Converts an AC voltage to a DC voltage.
- Regenerative feedback** A method of obtaining an increased output by feeding part of the output back to the input.
- Relaxation oscillator** Oscillator that stores energy during part of the oscillation cycle.
- Relay** An electromagnetic switch that opens and closes with an armature.
- Resistance** Opposition to electron flow in a circuit.
- Resistivity** The resistance a material offers to current flow.
- Resistors** Components manufactured to possess a specific value of resistance to the flow of current.
- Resonance** When both inductive and capacitance reactance in an AC circuit are equal at one particular frequency.
- Resonant circuit** A circuit that contains both inductive and capacitance reactance equal at one particular frequency.
- Reverse bias** A device connected so that current does not flow across the PN junction.
- RF amplifiers** See Radio-frequency amplifiers.
- Rheostat** A variable resistor used to control current.
- Ringing** Dampened oscillations occurring as the transient response of a resonant circuit to a shocked excitation.
- Rise time** Time it takes for a pulse to rise from 10% to 90% of maximum amplitude.
- rms value** Another term for effective value, root-mean-square.
- Rosin connection** A poor solder connection that is connected with rosin flux in place of solder.
- Rotate and shift instructions** Change the data in a register or memory by moving the data to the left or right one bit.
- RS flip-flop** A flip-flop with a set and reset input.
- Safety** The awareness of the work environment to protect human life and the equipment used.
- Saturation** Signifies that a transistor's collector-to-emitter junction is turned on and the transistor is conducting heavily.
- Schematic diagram** A diagram that uses symbols to represent an electrical or electronic circuit.
- Schmitt trigger** A modified bistable multivibrator that provides more regeneration.
- Scientific notation** The use of powers of ten to express large and small numbers.
- Secondary cell** Chemical cell that can be recharged.
- Semiconductor** A material that has four valence electrons.

- Series-aiding cells** Connecting positive terminal to negative terminal of cells.
- Series circuit** Provides a single path for current flow.
- Series-opposing cells** Connecting negative to negative terminal or positive to positive terminal of a cell.
- Series-parallel cells** Used to increase current and voltage outputs above that of a single cell.
- Series-parallel circuit** A combination of the series circuit and the parallel circuit.
- Series regulator** The regulating transistor is placed in series with the load.
- Series voltage regulator** Connected in series with the load.
- Shell** Orbit about the nucleus.
- Shift register** Constructed of flip-flops and used to store data temporarily.
- Short circuit** A circuit made inactive by a low resistance path across the circuit. Has zero ohms resistance.
- Shunt** Any part connected in parallel with some other part.
- Shunt regulator** The regulating transistor is placed in parallel with the load.
- Shunt voltage regulator** The voltage regulator is connected in parallel with the load.
- Siemen** The unit of conductance.
- Signal generator** Electrical test equipment that provides a calibrated frequency over a large range with a variable output.
- Silicon** Mineral recovered from silicon dioxide, found extensively in the earth's crust.
- Silicon control rectifier (SCR)** A thyristor that controls current flow in only one direction.
- Single-sided printed circuit board** A printed circuit board that contains the copper traces and pads on only one side.
- Sinusoidal oscillator** Oscillator that produces sine wave outputs.
- SIP (single in-line package)** An assembly consisting of two or more surface mounted components (SMC) on a single substrate. The SMCs are connected to each other and to pins at the edge of the substrate for through-hole mounting on a printed circuit board.
- SMD** *See* Surface mounted device.
- SMT** *See* Surface mount technology.
- Solar cell** *See* Photovoltaic cell.
- Solder** A tin/lead alloy with a low melting temperature that is used to form a permanent bond and reliable electrical connections.
- Solder side** Contains the copper traces for a single-sided circuit printed circuit board.
- Solder sucker** *See* Desoldering pump.
- Soldering** The forming of an electrical connection using solder.
- Soldering gun** A soldering iron that resembles a pistol and is capable of generating a high amount of heat. For heavy-duty soldering.
- Soldering iron** An electrical heating device that consists of a heating element that heats the tip to melt solder.
- Soldering iron tip** Transfers the heat to the connection being soldered.
- Solderless breadboard** A breadboard that has an array of holes spaced 0.10" apart to accept component leads and solid strand wires.
- Solenoid** A cylindrical coil with a movable plunger in the center.
- Stack** An area of memory used for temporary storage.
- Stack instructions** Allow the storage and retrieval of different microprocessor registers in the stack.
- Stack pointer** A register that holds memory locations of data stored in the stack.
- Static electricity** Produced when two substances are rubbed together or separated, resulting in the transfer of electrons from one substance to another.
- Step-down transformer** Transformer that produces a secondary voltage less than the primary one.
- Step-up transformer** Transformer that produces a secondary voltage greater than the primary one.
- Substrate** Forms the base for a semiconductor device.
- Subtractor** A logic circuit that performs subtraction of two binary numbers.
- Summing amplifier** Used when mixing audio signals together.
- Surface mount technology (SMT)** Technology that uses surface mounted components on the top and/or bottom of a printed circuit board.

- Surface mounted device (SMD)** A device for surface mounting as opposed to through-hole mounting.
- Switch** A device for directing or controlling the current flow in a circuit.
- Synchronous** Occurring at the same time.
- Tank circuit** Formed by connecting an inductor and a capacitor in parallel.
- Tap** A connection point made in the body of the secondary of a transformer.
- Temperature-controlled solder station** Provides a precise tip temperature through a closed loop circuit.
- Temporary magnets** Magnets that retain only a small portion of their magnetic properties.
- Thermocouple** A device used to convert heat into electrical energy.
- Thin small outline package** A variation of the first surface-mount package referred to as the Gull Wing that supports a wider body width.
- Thyristors** A broad range of semiconductor components used for electronically controlled switches.
- Time constant** The time relationship in L/R and RC circuits.
- Time domain concept** All waveforms can be changed from one shape to another using circuits.
- Tolerance** An indication of the amount a resistor may vary and still be acceptable.
- Trace** A substitute for wires in printed circuit board development.
- Trailing edge** The back edge of a waveform.
- Transformer** A device for transferring energy from one circuit to another.
- Transient** A temporary component of current existing in a circuit during adjustment to a load change, voltage source difference, or line impulse.
- Transistor** See Bipolar transistor.
- TRIAC** Acronym for *triode AC* semiconductor, provides full control of AC.
- Trivalent** Atoms with three valence electrons.
- Truth table** A table that lists all possible combinations of digital input and output levels for a gate.
- TSOP** Thin small outline package.
- Turns ratio** Determined by dividing number of turns in secondary by number of turns in primary.
- Up-down counter** A counter that can count in either direction.
- Undershoot** Occurs when the trailing edge exceeds its normal minimum value.
- Vacuum desoldering pump** Uses a vacuum pump to suck molten solder through a hollow-tip soldering iron for desoldering.
- Valence** Indication of an atom's ability to gain or lose electrons.
- Valence shell** The outer electron shell of an atom.
- Van de Graaf generator** A device used to generate electricity by means of friction.
- Variable capacitor** A capacitor whose value can be changed either by varying the space between plates (trimmer capacitor) or by varying the amount of meshing between two sets of plates (tuning capacitor).
- Vector** A graphic representation by an arrow of a quantity having magnitude and direction.
- Vector addition** The adding of vectors using observed rules.
- Veitch diagram** A chart used to simplify complex Boolean expressions.
- Video amplifier** Wideband amplifiers used to amplify video signals to 6 megahertz.
- Virtual breadboarding** A surrogate environment where circuits are created by computers to simulate the real environment to test a circuit design.
- Virtual test equipment** A surrogate environment where test equipment is created by computers to simulate real test equipment.
- Void** A soldering defect caused by impurities in the surface when soldering and too much heat.
- Volt** Unit for measuring voltage.
- Volt-ampere (VA)** A rating used for transformers, similar to a power rating.
- Voltage** Another name for difference of potential.
- Voltage amplifier** An audio amplifier used to produce a high gain.
- Voltage divider** A circuit used to divide a higher-voltage source to a lower voltage for a specific application.
- Voltage doubler** Produces a DC output voltage approximately twice the peak value of the input.

Voltage drop Occurs when current flows in a circuit.

Voltage multiplier A circuit capable of producing higher DC voltages without a transformer.

Voltage regulator Produces a constant output voltage regardless of change of load.

Voltage rise The voltage applied to a circuit.

Voltage tripler Produces an output voltage approximately three times the peak value of the input.

Voltmeter Device used to measure the voltage between two points in a circuit.

VOM (volt-ohm-milliammeter) Analog multimeter.

Watt Unit of power.

Wicking A soldering defect caused by too much heat resulting in capillary action pulling solder under the insulation of wires.

Wiring diagram A diagram that shows how off-board components are connected to one another and to the printed circuit board.

Zener diode Designed to operate at voltages that exceed breakdown voltage.

Zener region Region above breakdown, where zener diodes operate.

This page intentionally left blank

SELF-TEST ANSWERS

CHAPTER 1 FUNDAMENTALS OF ELECTRICITY

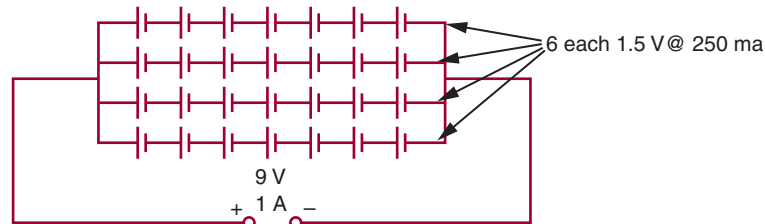
1. The number of free electrons that are available.
2. How many electrons are in the valence shell; less than four—conductor; four—semi-conductor; more than four—insulators.
3. To understand how electricity flows or does not flow through various materials.
4. The flow of electrons is current, the force that moves the electrons is voltage, and the opposition to the flow of electrons is resistance.
5. Resistance is measured in ohms and the amount of resistance that allows one ampere of current to flow when one volt is applied is one ohm.

CHAPTER 2 CURRENT

1. *Given:*
 $I = ?$
 $Q = 7 \text{ coulombs}$
 $t = 5 \text{ seconds}$
Solution:
 $I = \frac{Q}{t}$
 $I = \frac{7}{5}$
 $I = 1.4 \text{ amperes}$
2. Electrons flow from the negative terminal of the potential through the conductor, moving from atom to atom, to the positive terminal of the potential.
3. a. $235 = 2.35 \times 10^2$
b. $0.002376 = 2.376 \times 10^{-3}$
c. $56323.786 = 5.6323786 \times 10^4$
4. a. Milli means to divide by 1000 or to multiply by 0.001, expressed as 1×10^{-3} .
b. Micro means to divide by 1,000,000 or to multiply by 0.000001, expressed as 1×10^{-6} .

CHAPTER 3 VOLTAGE

1. The actual work accomplished in a circuit (the movement of electrons) is the result of the difference of potential (voltage).
2. Electricity can be produced by friction, magnetism, chemicals, light, heat, and pressure.
3. Secondary cells are rated in ampere-hours.
- 4.



5. *Given:*

$$E_T = 9 \text{ V}$$

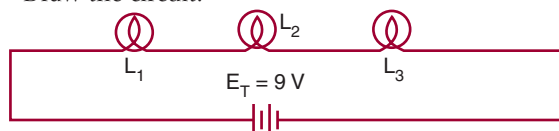
$$L_1 = 3 \text{ V rating}$$

$$L_2 = 3 \text{ V rating}$$

$$L_3 = 6 \text{ V rating}$$

Solution:

Draw the circuit:



1/2 the voltage would be dropped across L_1 and L_2 , and the other half of the voltage would be dropped across L_3 .

Therefore:

$$L_1 + L_2 = 6\text{-V drop}$$

$$L_3 = 6\text{-V drop}$$

$$9 \times \frac{1}{2} = 4.5 \text{ V}$$

$$L_3 \text{ would drop } 4.5 \text{ V}$$

$$L_2 \text{ would drop } 2.25 \text{ V}$$

$$L_1 \text{ would drop } 2.25 \text{ V}$$

$$\text{Total voltage } 9.00 \text{ V}$$

CHAPTER 4 RESISTANCE

1. The resistance of a material depends on the type of a material and its size, shape, and temperature. It is determined by measuring a 1-foot length of wire made of the material that is 1 mil in diameter and at a temperature of 20° Celsius.

2. *Given:*

$$\text{Resistance} = 2200 \text{ ohms}$$

$$\text{Tolerance} = 10\%$$

Solution:

$$2200 \times 0.10 = 220 \text{ ohms}$$

$$2200 - 220 = 1980 \text{ ohms}$$

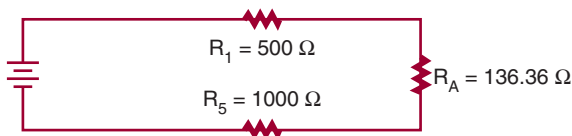
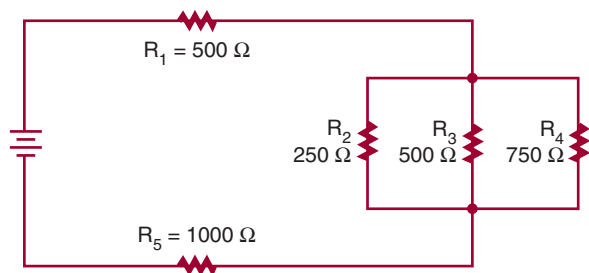
$$2200 + 220 = 2420 \text{ ohms}$$

Tolerance range is:

$$1980 \text{ ohms to } 2420 \text{ ohms}$$

3. a. Green, Blue, Red, Gold
- b. Brown, Green, Green, Silver
- c. Red, Violet, Gold, Gold
- d. Brown, Black, Brown, None
- e. Yellow, Violet, Yellow, Silver

4.

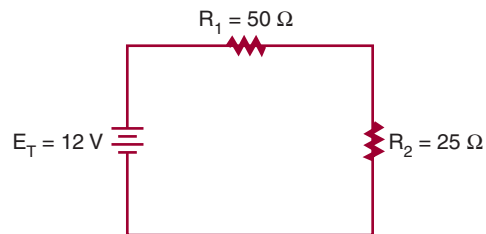


5. The current flows from the negative side of the voltage source through the series components, dividing among the branches of the parallel components, recombining to flow through any more series or parallel components, and then returns to the positive side of the voltage source.

CHAPTER 5 OHM'S LAW

1. *Given:* $I = ?$
 $E = 9 \text{ V}$
 $R = 4500 \Omega$
- Solution:*
 $I = \frac{E}{R}$
 $I = \frac{9}{4500}$
 $I = 0.002 \text{ A or } 2 \text{ mA}$
2. *Given:* $I = 250 \text{ mA} = 0.250 \text{ A}$
 $E = ?$
 $R = 470 \Omega$
- Solution:*
 $I = \frac{E}{R}$
 $0.250 = \frac{E}{470}$
 $\frac{0.250}{1} = \frac{E}{470}$
 $(1)(E) = (0.250)(470)$
 $E = 117.5 \text{ V}$
3. *Given:* $I = 10 \text{ A}$
 $E = 240 \text{ V}$
 $R = ?$
- Solution:*
 $I = \frac{E}{R}$
 $10 = \frac{240}{R}$
 $\frac{10}{1} = \frac{240}{R}$
 $(1)(240) = (10)(R)$
 $\frac{240}{10} = \frac{10R}{10}$
 $\frac{240}{10} = 1R$
 $24 \Omega = R$

4. a.



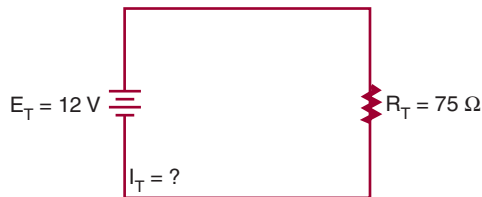
First, find the total resistance of the circuit (series).

$$R_T = R_1 + R_2$$

$$R_T = 50 + 25$$

$$R_T = 75 \Omega$$

Second, redraw the circuit using the total equivalent resistance.



Third, find the total current of the circuit.

Given:

Solution:

$$I_T = ?$$

$$I_T = \frac{E_T}{R_T}$$

$$E_T = 12 \text{ V}$$

$$I_T = \frac{12}{75}$$

$$R_T = 75 \Omega$$

$$I_T = 0.16 \text{ A or } 160 \text{ mA}$$

Now, find the voltage drop across R_1 and R_2 .

$$I_T = I_1 = I_2 \quad I_2 = \frac{E_2}{R_2}$$

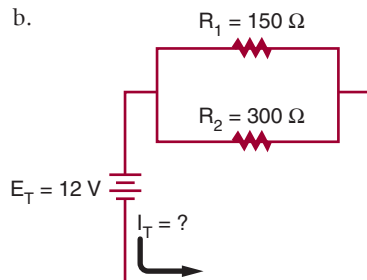
$$I_1 = \frac{E_1}{R_1} \quad 0.16 = \frac{E_2}{25}$$

$$0.16 = \frac{E_1}{50} \quad (0.16)(25) = E_2$$

$$(0.16)(50) = E_1 \quad 4\text{V} = E_2$$

$$8\text{V} = E_1$$

b.



First, find the total resistance of the circuit (parallel).

$$\frac{1}{R_T} = \frac{1}{R_1} + \frac{1}{R_2}$$

$$\frac{1}{R_T} = \frac{1}{150} + \frac{1}{300}$$

$$\frac{1}{R_T} = \frac{2}{300} + \frac{1}{300}$$

$$\frac{1}{R_T} = \frac{3}{300}$$

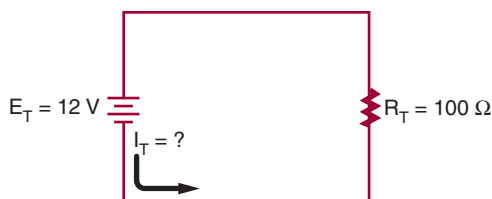
$$(3)(R_T) = (1)(300)$$

$$\cancel{3}(R_T) = \frac{300}{\cancel{3}}$$

$$1 R_T = \frac{300}{3}$$

$$R_T = 100 \Omega$$

Second, redraw the circuit with equivalent resistance.



Third, find the total resistance of the circuit.

Given:

Solution:

$$I_T = ?$$

$$I_T = \frac{E_T}{R_T}$$

$$E_T = 12 \text{ V}$$

$$I_T = \frac{12}{100}$$

$$R_T = 100 \Omega$$

$$I_T = 0.12 \text{ A or } 120 \text{ mA}$$

Now, find the branch currents for R_1 and R_2 .

$$E_T = E_1 = E_2$$

$$I_1 = \frac{E_1}{R_1}$$

$$I_2 = \frac{E_2}{R_2}$$

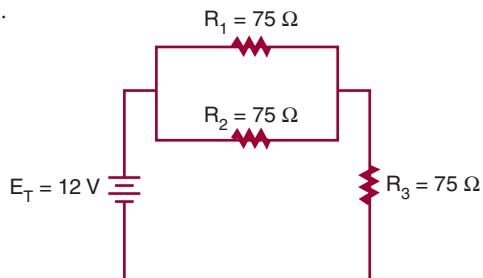
$$I_1 = \frac{12}{150}$$

$$I_2 = \frac{12}{300}$$

$$I_1 = 0.08 \text{ A or } 80 \text{ mA}$$

$$I_2 = 0.04 \text{ A or } 40 \text{ mA}$$

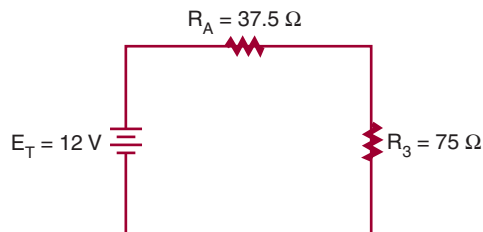
c.



First, find the equivalent resistance for the parallel portion of the circuit.

$$\begin{aligned}\frac{1}{R_A} &= \frac{1}{R_1} + \frac{1}{R_2} \\ \frac{1}{R_A} &= \frac{1}{75} + \frac{1}{75} \\ \frac{1}{R_A} &= \frac{2}{75} \\ (2)(R_A) &= (1)(75) \\ \frac{(2)(R_A)}{2} &= \frac{(1)(75)}{2} \\ 1R_A &= \frac{75}{2} \\ R_A &= 37.5 \Omega\end{aligned}$$

Second, redraw the circuit with equivalent resistance.



Third, find the total resistance of the circuit.

$$\begin{aligned}R_T &= R_A + R_3 \\ R_T &= 37.5 + 75 \\ R_T &= 112.5 \Omega\end{aligned}$$

Fourth, find the total current of the circuit.

Given:

Solution:

$$\begin{aligned}I_T &= ? & I_T &= \frac{E_T}{R_T} \\ E_T &= 12 \text{ V} & I_T &= \frac{12}{112.5} \\ R_T &= 112.5 \Omega & I_T &= 0.107 \text{ A or } 107 \text{ mA}\end{aligned}$$

Fifth, find voltage drops for R_3 and R_4 .

$$\begin{aligned}I_T &= I_A = I_3 \\ I_A &= 0.107 \text{ A} \\ I_3 &= 0.107 \text{ A}\end{aligned}$$

$$\begin{aligned}I_3 &= \frac{E_3}{R_3} & I_A &= \frac{E_A}{R_A} & E_A &= E_1 = E_2 \\ 0.107 &= \frac{E_3}{75} & 0.107 &= \frac{E_A}{37.5} & E_1 &= 4 \text{ V} \\ 8 \text{ V} &= E_3 & 4 \text{ V} &= E_A & E_2 &= 4 \text{ V}\end{aligned}$$

Now, find the branch current for R_1 and R_2 .

$$I_1 = \frac{E_1}{R_1}$$

$$I_2 = \frac{E_2}{R_2}$$

$$I_1 = \frac{4}{75}$$

$$I_2 = \frac{4}{75}$$

$$I_1 = 0.053\text{A or } 53\text{mA}$$

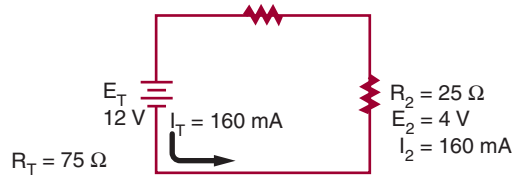
$$I_2 = 0.053\text{A or } 53\text{mA}$$

5. a.

$$R_T = 50 \Omega$$

$$E_T = 8 \text{ V}$$

$$I_T = 160 \text{ mA}$$



$$I_T = I_1 = I_2$$

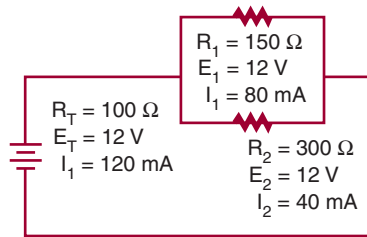
$$E_T = E_1 + E_2$$

$$160\text{mA} = 160\text{mA} = 160\text{mA}$$

$$12\text{V} = 8\text{V} = 4\text{V}$$

NOTE: Rounding may cause a difference in answers.

b.



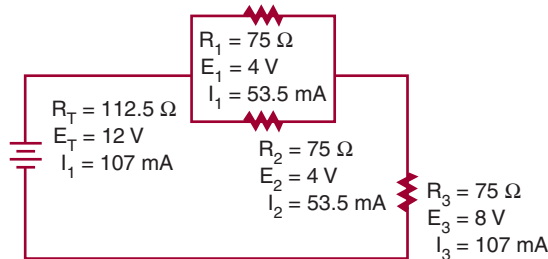
$$I_T = I_1 + I_2$$

$$E_T = E_1 = E_2$$

$$120\text{mA} = 80\text{mA} + 40\text{mA}$$

$$12\text{V} = 12\text{V} = 12\text{V}$$

c.



$$I_T = (I_1 + I_2) = I_3$$

$$E_T = (E_1 + E_2) + E_3$$

$$0.107 = (0.0535 + 0.0535) = 0.107$$

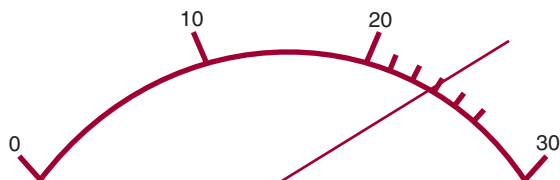
$$12 = (4 + 4) + 8$$

$$0.107\text{A} = 0.107\text{A} = 0.107\text{A}$$

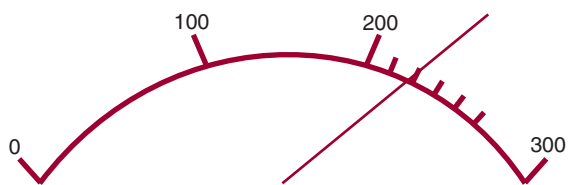
$$12\text{V} = 4\text{V} + 8\text{V}$$

CHAPTER 6 ELECTRICAL MEASUREMENTS—METERS

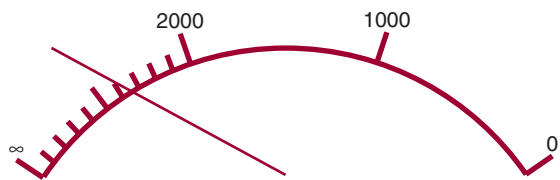
1. Digital
2. Analog
3. a. 23 volts



b. 220 milliamperes



c. 2700 ohms



4. One meter can be used to measure voltage, current, and resistance.

CHAPTER 7 POWER

1. *Given:*

$$P = ?$$

$$I = 40 \text{ mA} = 0.04 \text{ A}$$

$$E = 30 \text{ V}$$

2. *Given:*

$$P = 1 \text{ W}$$

$$I = 10 \text{ mA} = 0.01 \text{ A}$$

$$E = ?$$

Solution:

$$P = IE$$

$$P = (0.04)(30)$$

$$P = 1.2 \text{ W}$$

Solution:

$$P = IE$$

$$1 = (0.01)(E)$$

$$\frac{1}{0.01} = \frac{(0.01)(E)}{(0.01)}$$

$$\frac{1}{0.01} = 1E$$

$$100 \text{ V} = E$$

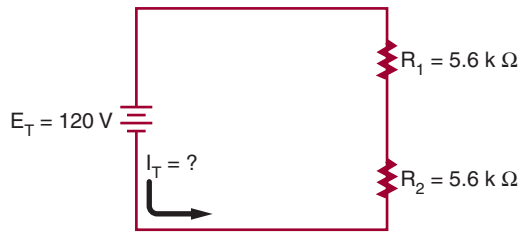
3. *Given:*
 $P = 12.3 \text{ W}$
 $I = ?$
 $E = 30 \text{ V}$

Solution:
 $P = IE$
 $12.3 = (I)(30)$
 $\frac{12.3}{30} = \frac{(I)(30)}{30}$
 $\frac{12.3}{30} = 11$

$$0.41 \text{ A} = I$$

$$I = 0.41 \text{ A or } 410 \text{ mA}$$

4. a.



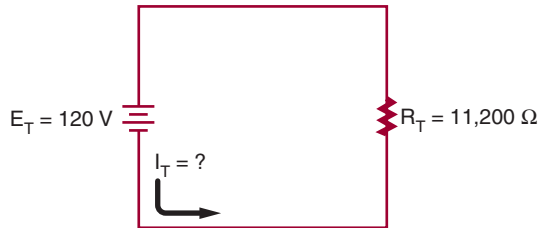
First, find the total resistance of the circuit (series).

$$R_T = R_1 + R_2$$

$$R_T = 5600 + 5600$$

$$R_T = 11,200 \Omega$$

Second, redraw the circuit using total resistance.



Third, find total circuit current.

Given:
 $I_T = ?$
 $E_T = 120 \text{ V}$
 $R_T = 11,200 \Omega$

Solution:
 $I_T = \frac{E_T}{R_T}$
 $I_T = \frac{120}{11,200}$
 $I_T = 0.0107 \text{ A or } 10.7 \text{ mA}$

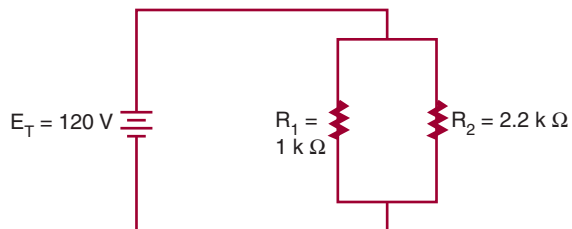
Now, find total circuit power.

$$P_T = I_T E_T$$

$$P_T = (0.0107)(120)$$

$$P_T = 1.28 \text{ W}$$

b.



First, find the total resistance of the circuit (parallel).

$$\begin{aligned} \frac{1}{R_T} &= \frac{1}{R_1} + \frac{1}{R_2} \\ \frac{1}{R_T} &= \frac{1}{1000} + \frac{1}{2200} \\ \frac{1}{R_T} &= 0.001 + 0.000455 \\ \frac{1}{R_T} &= 0.001455 \\ R_T &= \frac{0.001455}{1} \\ (0.001455)(R_T) &= (1)(1) \\ R_T &= \frac{1}{0.001455} \\ R_T &= 687.29 \Omega \end{aligned}$$

Second, redraw the circuit using total resistance.



Third, find the total circuit current.

Given:

Solution:

$$I_T = ?$$

$$I_T = \frac{E_T}{R_T}$$

$$E_T = 120 \text{ V}$$

$$I_T = \frac{120}{687.29}$$

$$R_T = 687.29 \Omega$$

$$I_T = 0.175 \text{ A or } 175 \text{ mA}$$

Now, find total circuit power.

Given:

Solution:

$$P_T = ?$$

$$P_T = I_T E_T$$

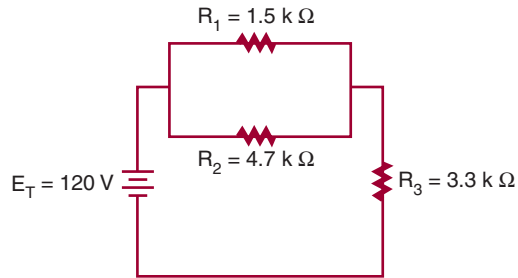
$$I_T = 0.175 \text{ A}$$

$$P_T = (0.175)(120)$$

$$E_T = 120 \text{ V}$$

$$P_T = 21 \text{ W}$$

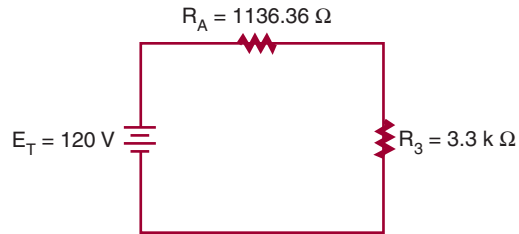
c.



First, find the equivalent resistance for the parallel portion of the circuit.

$$\begin{aligned} \frac{1}{R_T} &= \frac{1}{1500} + \frac{1}{4700} \\ \frac{1}{R_A} &= 0.000667 + 0.000213 \\ \frac{1}{R_A} &= 0.000880 \\ \frac{1}{R_A} &= \frac{0.000880}{1} \\ (0.000880)(R_A) &= (1)(1) \\ R_A &= \frac{1}{0.000880} \\ R_A &= 1,136.36 \Omega \end{aligned}$$

Second, redraw the circuit using the equivalent resistance.



Third, find the total resistance of the circuit.

$$\begin{aligned} R_T &= R_A + R_3 \\ R_T &= 1136.36 + 3300 \\ R_T &= 4436.36 \Omega \end{aligned}$$

Fourth, find the total current for the circuit.

Given:

$$I_T = ?$$

$$E_T = 120 \text{ V}$$

$$R_T = 4436.36 \Omega$$

Solution:

$$I_T = \frac{E_T}{R_T}$$

$$I_T = \frac{120}{4436.36}$$

$$I_T = 0.027 \text{ A or } 27 \text{ mA}$$

Fifth, find the total power for the circuit.

Given:

$$P_T = ?$$

$$I_T = 0.027 \text{ A}$$

$$E_T = 120 \text{ V}$$

Solution:

$$P_T = I_T E_T$$

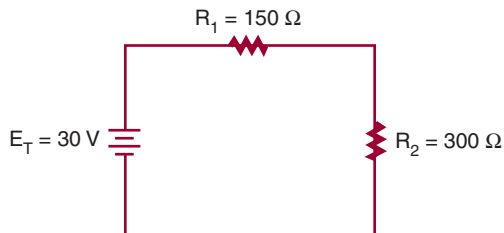
$$P_T = (0.027)(120)$$

$$P_T = 3.24 \text{ W (with rounding)}$$

$$3.25 \text{ W (without rounding)}$$

CHAPTER 8 DC CIRCUITS

1. a.



Find total circuit resistance.

$$R_T = R_1 + R_2$$

$$R_T = 150 + 300$$

$$R_T = 450 \Omega$$

Redraw the equivalent circuit.



Find total circuit current.

$$I_T = \frac{E_T}{R_T}$$

$$I_T = \frac{30}{450}$$

$$I_T = 0.0667 \text{ A or } 66.7 \text{ mA}$$

Find the voltage drop across each resistor.

$I_T = I_1 + I_2$ (the current flow in a series circuit is the same throughout the circuit)

$$I_{R_1} = \frac{E_{R_1}}{R_1}$$

$$0.0667 = \frac{E_{R_1}}{150}$$

$$\frac{0.0667}{1} = \frac{E_{R_1}}{150}$$

$$(1)(E_{R_1}) = (0.0667)(150)$$

$$E_{R_1} = (0.0667)(150)$$

$$E_{R_1} = 10 \text{ V}$$

$$I_{R_2} = \frac{E_{R_2}}{R_2}$$

$$0.0667 = \frac{E_{R_2}}{300}$$

$$\frac{0.0667}{1} = \frac{E_{R_2}}{300}$$

$$(1)(E_{R_2}) = (0.0667)(300)$$

$$E_{R_2} = (0.0667)(300)$$

$$E_{R_2} = 20 \text{ V}$$

Find the power for each resistor.

$$P_{R_1} = I_{R_1} E_{R_1}$$

$$P_{R_1} = (0.0667)(10)$$

$$P_{R_1} = 0.667 \text{ W}$$

$$P_{R_2} = I_{R_2} E_{R_2}$$

$$P_{R_2} = (0.0667)(20)$$

$$P_{R_2} = 1.334 \text{ W}$$

Find the total power of the circuit.

$$P_T = I_T E_T$$

$$P_T = (0.0667)(30)$$

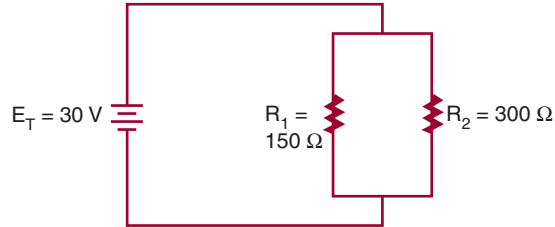
$$P_T = 2.001 \text{ W}$$

$$P_T = P_{R_1} + P_{R_2}$$

$$\text{or } P_T = 0.667 + 1.334$$

$$P_T = 2.001 \text{ W}$$

b.



Find the total circuit resistance.

$$\frac{1}{R_T} = \frac{1}{R_1} + \frac{1}{R_2}$$

$$\frac{1}{R_T} = \frac{1}{150} + \frac{1}{300}$$

$$\frac{1}{R_T} = \frac{2}{300} + \frac{1}{300}$$

$$\frac{1}{R_T} = \frac{3}{300}$$

$$(3)(R_T) = (1)(300)$$

$$\cancel{3}(R_T) = \frac{(1)(300)}{\cancel{3}}$$

$$R_T = \frac{300}{3}$$

$$R_T = 100 \Omega$$

Redraw the equivalent circuit.



Find the total circuit current.

$$I_T = \frac{E_T}{R_T}$$

$$I_T = \frac{30}{100}$$

$$I_T = 0.3 \text{ A or } 300 \text{ mA}$$

Find the current through each branch of the parallel circuit. The voltage is the same across each branch of the parallel circuit.

$$E_T = E_1 = E_2$$

$$I_{R_1} = \frac{E_{R_1}}{R_1} \qquad I_{R_2} = \frac{E_{R_2}}{R_2}$$

$$I_{R_1} = \frac{30}{150}$$

$$I_{R_2} = \frac{30}{300}$$

$$I_{R_1} = 0.2 \text{ A}$$

$$I_{R_2} = 0.1 \text{ A}$$

Find the power for each resistor.

$$P_{R_1} = I_{R_1} E_{R_1}$$

$$P_{R_2} = I_{R_2} E_{R_2}$$

$$P_{R_1} = (0.2)(30)$$

$$P_{R_2} = (0.1)(30)$$

$$P_{R_1} = 6 \text{ W}$$

$$P_{R_2} = 3 \text{ W}$$

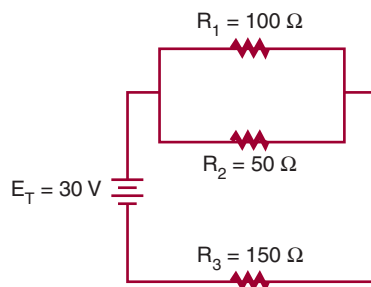
Find the total power of the circuit.

$$P_T = I_T E_T$$

$$P_T = (0.3)(30)$$

$$P_T = 9 \text{ W}$$

c.



Find the equivalent resistance for the parallel portion of the circuit.

$$\frac{1}{R_A} = \frac{1}{R_1} = \frac{1}{R_2}$$

$$\frac{1}{R_A} = \frac{1}{100} + \frac{1}{50}$$

$$\frac{1}{R_A} = \frac{1}{100} + \frac{2}{100}$$

$$\frac{1}{R_A} = \frac{3}{100}$$

$$(3)(R_A) = (1)(100)$$

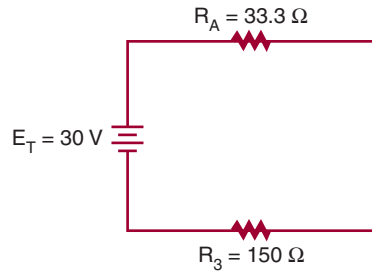
$$\cancel{3}(R_A) = \cancel{3}(1)(100)$$

$$R_A = \frac{100}{3}$$

$$R_A = \frac{100}{3}$$

$$R_A = 33.3 \Omega$$

Redraw the circuit.



Now find the total circuit resistance.

$$\begin{aligned} R_T &= R_A + R_3 \\ R_T &= 33.3 + 150 \\ R_T &= 183.3 \Omega \end{aligned}$$

Find the current flow (I_T) for the equivalent circuit.

$$\begin{aligned} I_T &= \frac{E_T}{R_T} \\ I_T &= \frac{30}{183.3} \\ I_T &= 0.164 \text{ A or } 164 \text{ mA} \end{aligned}$$

Find the voltage drop across resistors in equivalent circuit. (Current is the same throughout a series circuit.)

$$\begin{aligned} I_T &= I_{R_A} = I_{R_3} \\ I_{R_A} &= \frac{E_{R_A}}{R_A} & I_{R_3} &= \frac{E_{R_3}}{R_3} \\ 0.164 &= \frac{E_{R_A}}{33.3} & 0.164 &= \frac{E_{R_3}}{150} \\ (1)(E_{R_A}) &= (0.164)(33.3) & (1)(E_{R_3}) &= (0.164)(150) \\ E_{R_A} &= 5.46 \text{ V} & E_{R_3} &= 24.6 \text{ V} \end{aligned}$$

Find the current across each of the resistors in the parallel portion of the circuit.

$$\begin{aligned} I_{R_1} &= \frac{E_{R_1}}{R_1} & I_{R_2} &= \frac{E_{R_2}}{R_2} \\ I_{R_1} &= \frac{5.46}{100} & I_{R_2} &= \frac{5.46}{50} \\ I_{R_1} &= 0.056 \text{ A} & I_{R_2} &= 0.109 \text{ A} \end{aligned}$$

Find the power across each component and total power.

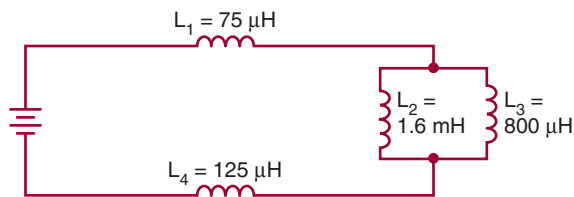
$$\begin{aligned} P_T &= I_T E_T & P_{R_1} &= I_{R_1} E_{R_1} & P_{R_2} &= I_{R_2} E_{R_2} & P_{R_3} &= I_{R_3} E_{R_3} \\ P_T &= (0.164)(30) & P_{R_1} &= (0.056)(5.46) & P_{R_2} &= (0.109)(5.46) & P_{R_3} &= (0.164)(24.6) \\ P_T &= 4.92 \text{ W} & P_{R_1} &= 0.298 \text{ W} & P_{R_2} &= 0.595 \text{ W} & P_{R_3} &= 4.034 \text{ W} \end{aligned}$$

CHAPTER 9 MAGNETISM

- The domain theory of magnetism can be verified by jarring the domains into a random arrangement by heating or hitting with a hammer. The magnet will eventually lose its magnetism.
- The strength of an electromagnet can be increased by increasing the number of turns of wire, increasing the current flow, and by inserting a ferromagnetic core in the center of the coil.
- In Figure 9–15, when the loop is rotated from position A to position B, a voltage is induced when the motion is at right angles to the magnetic field. As the loop is rotated to position C, the induced voltage decreases to zero volts. As the loop continues to position D, a voltage is again induced, but the commutator reverses the output polarity so it is the same as was first output by the DC generator. The output pulsates in one direction, varying twice during each revolution between zero and maximum.

CHAPTER 10 INDUCTANCE

- The magnetic field around an inductor can be increased by using an iron core.
-



Given:

$$L_1 = 75 \mu\text{H}$$

$$L_2 = 1.6 \text{ mH} = 1600 \mu\text{H}$$

$$L_3 = 800 \mu\text{H}$$

$$L_4 = 125 \mu\text{H}$$

Solution:

$$\frac{1}{L_p} = \frac{1}{L_2} + \frac{1}{L_3}$$

$$\frac{1}{L_p} = \frac{1}{0.0016} + \frac{1}{0.0008}$$

$$\frac{1}{L_p} = 1875$$

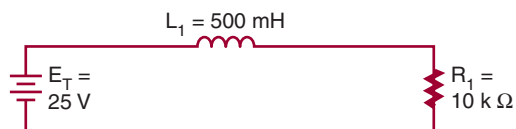
$$L_p = 533.33 \mu\text{H}$$

$$L_T = L_1 + L_p + L_4$$

$$L_T = 75 \mu\text{H} + 533.33 \mu\text{H} + 125 \mu\text{H}$$

$$L_T = 733.33 \mu\text{H}$$

- First, draw the circuit:



Given:

$$E_T = 25 \text{ V}$$

$$L_1 = 500 \text{ mH} = 0.5 \text{ H}$$

$$R_1 = 10 \text{ k}\Omega = 10,000 \Omega$$

Solution:

$$t = \frac{L}{R}$$

$$t = \frac{0.5}{10,000}$$

$$t = 0.00005$$

$$t = 50 \mu\text{sec}$$

100 μsec = 2 time constants, energized 86.5%

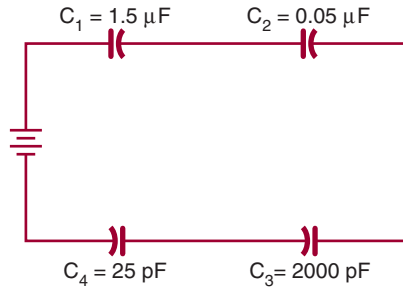
$25 \times 86.5\% = 21.63 \text{ V}$

This voltage represents E_R on rise.

$$\begin{aligned} E_L &= E_T - E_R \\ E_L &= 25 - 21.63 \\ E_L &= 3.37 \text{ V} \end{aligned}$$

CHAPTER 11 CAPACITANCE

- The charge is stored on the plates of the capacitor.
- First, draw the circuit:



Given:

$$C_1 = 1.5 \mu\text{F}$$

$$C_2 = 0.05 \mu\text{F}$$

$$C_3 = 2000 \text{ pF} = 0.002 \mu\text{F}$$

$$C_4 = 25 \text{ pF} = 0.000025 \mu\text{F}$$

Solution:

$$\frac{1}{C_T} = \frac{1}{C_1} + \frac{1}{C_2} + \frac{1}{C_3} + \frac{1}{C_4}$$

$$\frac{1}{C_T} = \frac{1}{1.5} + \frac{1}{0.05} + \frac{1}{0.002} + \frac{1}{0.000025}$$

$$\frac{1}{C_T} = 0.667 + 20 + 500 + 40000$$

$$\frac{1}{C_T} = 40,520.667$$

$$\frac{1}{C_T} = \frac{40,520.667}{1}$$

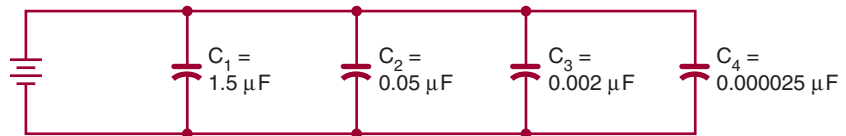
$$(40,520.667)(C_T) = (1)(1)$$

$$C_T = \frac{1}{40,520.667}$$

$$C_T = 0.000024678$$

$$C_T = 24.678 \text{ pF}$$

- First draw the circuit.



Given:

$$C_1 = 1.5 \mu\text{F}$$

$$C_2 = 0.05 \mu\text{F}$$

$$C_3 = 2000 \text{ pF} = 0.002 \mu\text{F}$$

$$C_4 = 25 \text{ pF} = 0.000025 \mu\text{F}$$

Solution:

$$C_T = C_1 + C_2 + C_3 + C_4$$

$$C_T = 1.5 + 0.05 + 0.002 + 0.000025$$

$$C_T = 1.552025 \mu\text{F} \text{ or } 1.55 \mu\text{F}$$

CHAPTER 12 ALTERNATING CURRENT

1. A conductor must be placed in a magnetic field in order for magnetic induction to occur.
2. To apply the left-hand rule, the thumb is pointed in the direction of the conductor movement, the index finger (extended at right angles to the thumb) indicates the direction of the magnetic lines of flux from north to south, and the middle finger (extended at a right angle to the index finger) indicates the direction of current flow in the conductor. The left-hand rule is used to determine the direction of current flow in a conductor that is being passed through a magnetic field.
3. The peak-to-peak value is the vertical distance between the two peaks of a waveform.
4. The effective value of alternating current is the amount that will produce the same degree of heat in a given resistance as an equal amount of direct current.
5. a. Square wave:



- b. Triangular wave:



- c. Sawtooth wave:



6. Nonsinusoidal waveforms can be considered as being constructed by algebraic addition of sine waves having different frequencies (harmonics), amplitudes, and phases.

CHAPTER 13 AC MEASUREMENTS

1. A DC meter movement can be used to measure AC by using rectifiers to convert the AC signal to a DC current.
2. The clamp-on ammeter uses a split-core transformer. The core can be opened and placed around the conductor. A voltage is induced into the core, which is also cut by a coil. The induced voltage creates a current flow that is rectified and sent to a meter movement.
3. An oscilloscope can provide the following information about an electronic circuit: the frequency of a signal, the duration of a signal, the phase relationship between signal waveforms, the shape of a signal's waveform, and the amplitude of a signal.
4. Initially set the oscilloscope controls as follows: intensity, focus, astigmatism, and position controls (set to the center of their range)

Triggering: INT +

Level: Auto

Time/CM: 1 msec

Volts/CM: 0.02

Power: On

Connect the oscilloscope probe to the test jack of the voltage calibrator. Adjust the controls for a sharp, stable image of a square wave; check the values shown on the scope display against those set on the voltage calibrator.

5. A frequency counter consists of a time base, an input-signal conditioner, a gate-control circuit, a main gate, a decade counter, and a display.
 Time base: compensates for the different frequencies being measured.
 Signal conditioner: converts the input signal to a waveshape and amplitude compatible with the circuitry in the counter.
 Gate-control circuitry: acts as the synchronization center of the counter. It opens and closes the main gate and provides a signal to latch the count at the end of the counting period and resets the circuitry for the next count.
 Main gate: passes the conditioned input signal to the counter circuit.
 Decade counter: keeps a running tally of all the pulses that pass through the main gate.
 Display: provides a visual readout of the frequency being measured.
6. The integrated circuit has been the primary force for moving the frequency counter from the laboratory to the work bench. It has reduced the physical size of the counter.
7. To check the frequency response of a circuit.

CHAPTER 14 RESISTIVE AC CIRCUITS

1. In a pure resistive AC circuit the current and voltage waveforms are in phase.
2. *Given:*

$$I_T = 25 \text{ mA} = 0.025 \text{ A}$$

$$E_T = ?$$

$$R_T = 4.7 \text{ k}\Omega = 4700 \Omega$$

Solution:

$$I_T = \frac{E_T}{R_T}$$

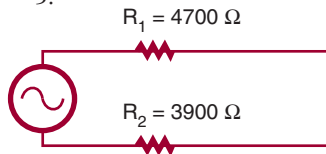
$$0.025 = \frac{E_T}{4700}$$

$$\frac{0.025}{1} \times \frac{E_T}{4700}$$

$$(1)(E_T) = (0.025)(4700)$$

$$E_T = 117.5 \text{ V}$$

3.



Given:

$$I_T = ?$$

$$E_T = 12 \text{ V}$$

$$R_T = ?$$

$$R_1 = 4.7 \text{ k}\Omega = 4700 \Omega$$

$$R_2 = 3.9 \text{ k}\Omega = 3900 \Omega$$

$$E_1 = ?$$

$$E_2 = ?$$

Solution:

$$R_T = R_1 + R_2 \quad I_T = \frac{E_T}{R_T}$$

$$R_T = 4700 + 3900 \quad I_T = \frac{12}{8600}$$

$$R_T = 8600 \quad I_T = 0.0014 \text{ A}$$

or 1.4 mA

$$I_T = I_1 = I_2$$

$$I_2 = \frac{E_2}{R_2} \quad (1)(E_2) = (0.0014)(3900)$$

$$E_2 = 5.46 \text{ V}$$

$$I_1 = \frac{E_1}{R_1} \quad \frac{0.0014}{1} \times \frac{E_1}{4700}$$

$$0.0014 = \frac{E_1}{4700} \quad (1)(E_1) = (0.0014)(4700) \quad 0.0014 = \frac{E_2}{3900}$$

$$E_1 = 6.58 \text{ V}$$

$$\frac{0.0014}{1} \times \frac{E_2}{3900}$$

4. *Given:*
- $$E_T = 120 \text{ V}$$
- $$R_1 = 2.2 \text{ k}\Omega = 2200 \ \Omega$$
- $$R_2 = 5.6 \text{ k}\Omega = 5600 \ \Omega$$
- $$I_1 = ?$$
- $$I_2 = ?$$
- Solution:*
- $$E_T = E_1 = E_2$$
- $$I_1 = \frac{E_1}{R_1}$$
- $$I_1 = \frac{120}{2200}$$
- $$I_1 = 0.055 \text{ A or } 55 \text{ mA}$$
- $$I_2 = \frac{E_2}{R_2}$$
- $$I_2 = \frac{120}{5600}$$
- $$I_2 = 0.021 \text{ A or } 21 \text{ mA}$$
5. The rate at which energy is delivered to a circuit or energy (heat) is dissipated determines the power consumption in an AC circuit, just as in a DC circuit.
6. *Given:*
- $$I_T = ?$$
- $$E_T = 120 \text{ V}$$
- $$R_T = 1200 \ \Omega$$
- $$P_T = ?$$
- Solution:*
- $$I_T = \frac{E_T}{R_T}$$
- $$I_T = \frac{120}{1200}$$
- $$I_T = 0.1 \text{ A or } 100 \text{ mA}$$
- $$P_T = I_T E_T$$
- $$P_T = (0.1)(120)$$
- $$P_T = 12 \text{ W}$$

CHAPTER 15 CAPACITIVE AC CIRCUITS

- In a capacitive AC circuit, the current leads the applied voltage.
- Given:*
$$X_C = ?$$

$$\pi = 3.14$$

$$f = 60 \text{ Hz}$$

$$C = 1000 \ \mu\text{F} = 0.001 \text{ F}$$

Solution:

$$X_C = \frac{1}{2\pi fC}$$

$$X_C = \frac{1}{(2)(3.14)(60)(0.001)}$$

$$X_C = \frac{1}{0.3768}$$

$$X_C = 2.65 \ \Omega$$
- Given:*
$$I_T = ?$$

$$E_T = 12$$

$$X_C = 2.65 \ \Omega$$

Solution:

$$I_T = \frac{E_T}{X_C}$$

$$I_T = \frac{12}{2.65}$$

$$I_T = 4.53 \text{ A}$$
- Capacitive AC circuits can be used for filtering, coupling, decoupling, and phase shifting.
- Capacitive coupling circuits allow AC components of a signal to pass through a coupling network, while at the same time blocking the DC components of the signal.

CHAPTER 16 INDUCTIVE AC CIRCUITS

- In an inductive circuit, the current lags the applied voltage.
- The inductive reactance of an inductive circuit is affected by the inductance of the inductor and the frequency of the applied voltage.
- Given:*
$$X_L = ?$$

$$\pi = 3.14$$

Solution:

$$X_L = 2\pi fL$$

$$X_L = (2)(3.14)(60)(0.1)$$

$$f = 60 \text{ Hz} \qquad X_L = 37.68 \ \Omega$$

$$L = 100\text{mH} = 0.1 \text{ H}$$

4. *Given:* *Solution:*

$$I_T = ? \qquad I_T = \frac{E_T}{X_L}$$

$$E_T = 24 \text{ V} \qquad I_T = \frac{24}{37.68}$$

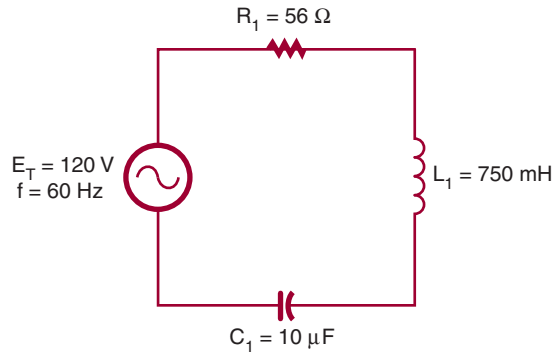
$$X_L = 37.68 \ \Omega \qquad I_T = 0.64 \text{ A or } 640 \text{ mA}$$

5. Applications for inductors in circuits include filtering and phase shifting.

6. The frequency above or below the frequencies passed or attenuated in an inductive circuit is called the cut-off frequency.

CHAPTER 17 RESONANCE CIRCUITS

1.



Find capacitive reactance.

$$X_C = \frac{1}{2\pi fC}$$

$$X_C = \frac{1}{(6.28)(60)(0.000010)}$$

$$X_C = 265.39 \ \Omega$$

Find inductive reactance.

$$X_L = 2\pi fL$$

$$X_L = (6.28)(60)(0.750)$$

$$X_L = 282.60 \ \Omega$$

Now, solve for X.

$$X = X_L - X_C$$

$$X = 282.6 - 265.39$$

$$X = 17.2 \ \Omega \text{ (inductive)}$$

Using X, solve for Z.

$$Z^2 = X^2 + R^2$$

$$Z^2 = (17.21)^2 + (56)^2$$

$$Z^2 = 296.18 + 3136$$

$$Z^2 = 3432.18$$

$$Z = \sqrt{3432.18}$$

$$Z = 58.58 \ \Omega$$

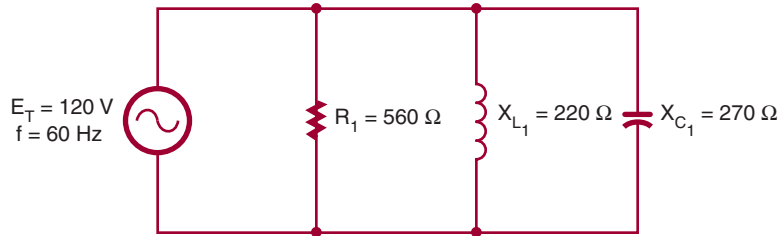
Solve for total current.

$$I_T = \frac{E_T}{Z}$$

$$I_T = \frac{120}{58.58}$$

$$I_T = 2.05 \text{ A}$$

2.



Find individual branch current.

$$I_R = \frac{E_R}{R} \qquad I_{X_L} = \frac{E_{X_L}}{X_L} \qquad I_{X_C} = \frac{E_{X_C}}{X_C}$$

$$I_R = \frac{120}{560} \qquad I_{X_L} = \frac{120}{220} \qquad I_{X_C} = \frac{120}{270}$$

$$I_T = 0.214 \text{ A} \qquad I_{X_L} = 0.545 \text{ A} \qquad I_{X_C} = 0.444 \text{ A}$$

Find I_X and I_Z using I_R , I_{X_L} and I_{X_C} .

$$I_X = I_{X_L} - I_{X_C} \qquad I_Z^2 = (I_R)^2 = (I_X)^2$$

$$I_X = 0.545 - 0.444 \qquad I_Z^2 = (0.214)^2 + (0.101)^2$$

$$I_X = 0.101 \text{ A (inductive)} \qquad I_Z = 0.237 \text{ A}$$

CHAPTER 18 TRANSFORMERS

- When two electrically isolated coils are placed next to each other, and an AC voltage is applied across one coil, the changing magnetic field induces a voltage into the second coil.
- Transformers are rated in volt-amperes rather than in watts because of the different types of loads that can be placed on the secondary winding. A pure capacitive load will cause an excessive current to flow and a power rating would have little meaning.
- If a transformer is connected without a load, there is no secondary current flow. The primary windings act like an inductor in an AC circuit. When a load is connected across the secondary winding, a current is induced into the secondary. The current in the secondary establishes its own magnetic field, which cuts the primary, inducing a voltage back into the primary. This induced field expands in the same direction as the current in the primary, aiding it and causing it to increase.
- Given:*

Solution:

$$N_P = 400 \text{ turns} \qquad \frac{E_S}{E_P} = \frac{N_S}{N_P} \qquad \text{turn ratio} = \frac{N_S}{N_P}$$

$$N_S = ? \qquad \frac{12}{20} = \frac{N_S}{400} \qquad = \frac{40}{400}$$

$$E_P = 120 \text{ V} \qquad 1N_S = \frac{(12)(400)}{20} \qquad = \frac{1}{10} \text{ or } 10:1$$

$$E_S = 12 \text{ V} \qquad N_S = 40 \text{ turns}$$

5. *Given:*

$$N_P = ?$$

$$N_S = ?$$

$$Z_P = 16$$

$$Z_S = 4$$

Solution:

$$\frac{Z_P}{Z_S} = \left(\frac{N_P}{N_S}\right)^2 \quad \sqrt{4} = \frac{N_P}{N_S}$$

$$\frac{16}{4} = \left(\frac{N_P}{N_S}\right)^2 \quad \frac{2}{1} = \frac{N_P}{N_S}$$

The turns ratio is 2:1.

- Transformers are important for transmitting electrical power because of power loss. The amount of power loss is related to the amount of resistance of the power lines and amount of current. The easiest way to reduce power losses is to keep the current low by stepping up the voltage with transformers.
- An isolation transformer prevents connecting to ground on either side of the power line for equipment being worked on.

CHAPTER 19 SEMICONDUCTOR FUNDAMENTALS

- Silicon has more resistance to heat than germanium, making it preferable.
- Covalent bonding is the process of atoms sharing electrons. When semiconductor atoms share electrons, their valence shell becomes full with eight electrons, thereby obtaining stability.
- In pure semiconductor materials, the valence electrons are held tightly to the parent atom at low temperatures and do not support current flow. As the temperature increases, the valence electrons become agitated and break the covalent bond, allowing the electrons to drift randomly from one atom to the next. As the temperature continues to increase, the material begins to behave like a conductor. Only at extremely high temperatures will silicon conduct current as ordinary conductors do.
- To convert a block of pure silicon to N-type material, the silicon is doped with atoms having five valence electrons, called *pentavalent materials*, such as arsenic and antimony.
- When a voltage is applied to N-type material, the free electrons contributed by the donor atoms flow toward the positive terminal. Additional electrons break away from their covalent bonds and also flow toward the positive terminal.

CHAPTER 20 PN JUNCTION DIODES

- A PN junction diode allows current to flow in only one direction.
- A diode will conduct when it is forward biased. That is, the positive terminal of the voltage source is connected to the P-type material, and the negative terminal of the voltage source is connected to the N-type material.



CHAPTER 21 ZENER DIODES

- In a zener diode voltage regulator, the zener diode is connected in series with a resistor with the output taken across the zener diode. The zener diode opposes an increase in input voltage, because when the current increases the resistance drops. The change in input voltage appears across the series resistor.

2. A power supply, current-limiting resistor, an ammeter and a voltmeter are required for testing a zener diode. The output of the power supply is connected across the limiting resistor in series with the zener diode and ammeter. The voltmeter is connected across the zener diode. The output voltage is slowly increased until the specified current is flowing through the zener diode. The current is then varied on either side of the specified zener current. If the voltage remains constant, the zener diode is operating properly.

CHAPTER 22 BIPOLAR TRANSISTORS

1. The emitter-based junction is forward biased, and the collector-based junction is reverse biased.
2. When testing a transistor with an ohmmeter, a good transistor will show a low resistance when forward biased and a high resistance when reverse biased across each junction.
3. A voltmeter, not an ohmmeter, is used to determine whether a transistor is silicon or germanium by measuring the voltage drop across the junction. The leads would be difficult to determine because it would be hard to say which end is the emitter or collector. However, the base would be determined as low resistance when forward biased to either emitter or collector and high resistance when reverse biased. A PNP or NPN transistor could be determined.
4. The collector voltage determines whether the device is an NPN or PNP transistor. If the wrong type of transistor is substituted, a failure in the device will result.
5. Testing a transistor with a transistor tester, especially an in-current tester, reveals more information about a transistor than when testing with an ohmmeter.

CHAPTER 23 FIELD EFFECT TRANSISTORS (FETS)

1. The pinch-off voltage is the voltage required to pinch off the drain current for a JFET.
2. The pinch-off voltage is given by the manufacturer for a gate-source voltage of zero.
3. Depletion-mode MOSFETs conduct when zero bias is applied to the gate. They are considered to be normally on devices.
4. Enhancement-mode MOSFETs are normally off and only conduct when a suitable bias voltage is applied to the gate.
5. Safety precautions for a MOSFET include:
 - Keep the leads shorted together prior to installation.
 - Use a metallic wrist band to ground the hand being used.
 - Use a grounded-tip soldering iron.
 - Always ensure the power is off prior to installation and removal of a MOSFET.

CHAPTER 24 THYRISTORS

1. The PN junction diode has one junction and two leads (anode and cathode); an SCR has three junctions and three leads (anode, cathode, and gate).
2. The anode supply voltage will keep the SCR turned on even after the gate voltage is removed. This allows a current to flow continuously from cathode to anode.
3. The load resistor is in series with the SCR to limit the cathode-to-anode current.
4. An SCR can be tested with an ohmmeter or a commercial transistor tester. To test the SCR with an ohmmeter, connect the positive lead to the cathode and the negative lead to the anode. A high-resistance reading in excess of 1 megohm should be read. Reverse the leads so the positive lead is on the anode and the negative lead is on the

cathode. Again, a high-resistance reading in excess of 1 megohm should be read. Short the gate to the anode, and the resistance reading should drop to less than 1000 ohms. Remove the short, and the low-resistance reading should remain. Remove the leads and repeat the test.

5. A DIAC is used as a triggering device for TRIACs. It prevents the TRIAC from turning on until a certain gate voltage is reached.

CHAPTER 25 INTEGRATED CIRCUITS

1. A hybrid integrated circuit contains monolithic, thin-film, and discrete components.
2. A chip is the semiconductor material that comprises the integrated circuit and is about one-eighth of an inch square.
3. Resistors and capacitors in an integrated circuit are formed by methods other than monolithic because of the accuracy required. It is not possible to adjust the values as well as with thin and thick film techniques; it is also not possible to obtain sufficient power handling capabilities.

CHAPTER 26 OPTOELECTRIC DEVICES

1. The photodiode has the fastest response time to light changes of any photosensitive devices.
2. The phototransistor lends itself to a wider range of applications because it is able to produce a higher gain. It does not, however, respond to light changes as fast as the photodiode.
3. The more current that flows through an LED, the brighter the light emitted. However, a series resistor must be used with LEDs to limit the current flow or else damage to the LED will result.

CHAPTER 27 POWER SUPPLIES

1. Concerns when selecting a transformer for a power supply include primary power rating, frequency of operation, secondary voltage and current rating, and power-handling capabilities.
2. Transformers are used to isolate the power supply from the AC voltage source. They can also be used to step up or step down voltage.
3. The rectifier in a power supply converts the incoming AC voltage to a DC voltage.
4. A disadvantage of the full-wave rectifier is that it requires a center-tapped transformer. An advantage is that it only requires two diodes. An advantage of the bridge rectifier is that it does not require a transformer; however, it does require four diodes. Both rectifier circuits are more efficient and easier to filter than the half-wave rectifier.
5. A filter capacitor charges when current is flowing, then discharges when current stops flowing, keeping a constant current flow on the output.
6. Capacitors are selected for filtering to give a long RC time constant. The slower discharge gives a higher output voltage.
7. A series regulator compensates for higher voltages on the input by increasing the series resistance, thereby dropping more voltage across the series resistance so the output voltage remains the same. It also senses lower voltage on the input, decreasing the series resistance and dropping less voltage, resulting in the output remaining the same. It works in a similar fashion on changes in the load.
8. The voltage and load current requirements must be known when selecting an IC voltage regulator.

9. Voltage multipliers allow the voltage of a circuit to be stepped up without the use of a step-up transformer.
10. The full-wave voltage doubler is easier to filter than the half-wave voltage doubler. In addition, the capacitors in the full-wave voltage doubler are subjected to only the peak value of the input signal.
11. An over-voltage protection circuit called a *crowbar* is used to protect the load from failure of the power supply.
12. Overcurrent protection devices include fuses and circuit breakers.

CHAPTER 28 AMPLIFIER BASICS

1. A transistor provides amplification by using an input signal to control current flow in the transistor to control the voltage through a load.
2. A common emitter circuit provides both voltage and current gain and a high power gain. Neither of the other two circuit configurations provides this combination.
3. Temperature changes affect the gain of a transistor. Degenerative or negative feedback compensates for this condition.
4. Class A amplifiers are biased so that the output flows throughout the entire cycle. Class B amplifiers are biased so that the output flows for only half of the input cycle. Class AB amplifiers are biased so that the output flows for more than half but less than the full input cycle. Class C amplifiers are biased so the output flows for less than half of the input cycle.
5. When connecting two transistor amplifiers together, the bias voltage from one amplifier must be prevented from affecting the operation of the second amplifier.
6. If capacitors or inductors are used for coupling, the reactance of the device will be affected by the frequency being transmitted.

CHAPTER 29 AMPLIFIER APPLICATIONS

1. DC or direct-coupled amplifiers are used to amplify frequencies from DC (0 hertz) to many thousands of hertz.
2. Temperature stability with DC amplifiers is achieved by using a differential amplifier.
3. Audio voltage amplifiers provide a high voltage gain, whereas audio power amplifiers provide high power gains to a load.
4. The complementary push-pull amplifier requires matched NPN and PNP transistors. The quasi-complementary amplifier does not require matched transistors.
5. A video amplifier has a wider frequency range than an audio amplifier.
6. A factor that limits the output of a video amplifier is the shunt capacitance of the circuit.
7. An RF amplifier amplifies frequencies from 10,000 hertz to 30,000 megahertz.
8. An IF amplifier is a single-frequency amplifier used to increase a signal to a usable level.
9. An op-amp consists of an input stage (differential amplifier), high-gain voltage amplifier, and an output amplifier. It is a high-gain DC amplifier, capable of output gains of 20,000 to 1,000,000 times the input signal.
10. Op-amps are amplifiers used for comparing, inverting, and noninverting a signal, and summing. They are also used as an active filter and a difference amplifier.

CHAPTER 30 OSCILLATORS

1. The parts of an oscillator include the frequency-determining circuit called the tank circuit, an amplifier to increase the output signal from the tank circuit, and a feedback circuit to deliver part of the output signal back to the tank circuit to maintain oscillation.

2. The tank circuit can sustain oscillation by feeding back part of the output signal in the proper phase to replace the energy losses caused by the resistance of the components in the tank circuit.
3. The major types of sinusoidal oscillators are the Hartley oscillator, the Colpitts oscillator, and the Clapp oscillator.
4. Crystals have a natural frequency of vibration and are ideal for oscillator circuits. The crystal frequency is used to control the tank circuit frequency.
5. Nonsinusoidal oscillators do not produce sine-wave outputs. Typically, all nonsinusoidal oscillators are some form of a relaxation oscillator.
6. Blocking oscillators, multivibrators, RC networks, and integrated circuits are all used in nonsinusoidal oscillators.

CHAPTER 31 WAVESHAPING CIRCUITS

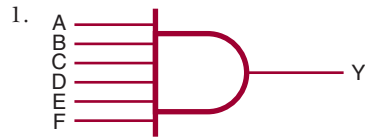
1. The frequency domain concept states that all periodic waveforms are made up of sine waves. A periodic waveform can be made by superimposing a number of sine waves having different amplitudes, phases, and frequencies.
2. Overshoot, undershoot, and ringing occur in waveshaping because of imperfect circuits that cannot react in zero time to a rapidly changing input.
3. A differentiator is used to produce a pip or peaked waveform for timing and synchronizing circuits. An integrator is used to produce a raising or falling triangular waveform for waveshaping.
4. The DC reference level of a signal can be changed by using a clamped circuit to clamp the waveform to a DC voltage.
5. A monostable circuit has only one stable state, and produces one output pulse for each input pulse. A bistable circuit has two stable states, and requires two input pulses to complete a cycle.
6. A flip-flop can produce a square or rectangular waveform for gating and timing signals or for switching applications.

CHAPTER 32 BINARY NUMBER SYSTEM

- | | | | | | | | |
|------------|--------|---------|--------|---------|--------|---------|--------|
| 1. Digital | Binary | Digital | Binary | Digital | Binary | Digital | Binary |
| 0 | 00000 | 7 | 00111 | 14 | 01110 | 21 | 10101 |
| 1 | 00001 | 8 | 01000 | 15 | 01111 | 22 | 10110 |
| 2 | 00010 | 9 | 01001 | 16 | 10000 | 23 | 10111 |
| 3 | 00011 | 10 | 01010 | 17 | 10001 | 24 | 11000 |
| 4 | 00100 | 11 | 01011 | 18 | 10010 | 25 | 11001 |
| 5 | 00101 | 12 | 01100 | 19 | 10011 | 26 | 11010 |
| 6 | 00110 | 13 | 01101 | 20 | 10100 | 27 | 11011 |
2. Seven binary bits are required to represent the decimal number 100 (1100100).
 3. To convert a decimal number to a binary number, progressively divide the decimal number by 2, writing down the remainder after each division. The remainders, taken in reverse order, form the binary number.
 4.
 - a. $100101.001011 = 37.171875$
 - b. $111101110.11101110 = 494.9296875$
 - c. $1000001.00000101 = 129.019587$
 5. Convert each decimal digit to a binary digit (0–9) using a 4-bit BCD binary code for decimal digit.

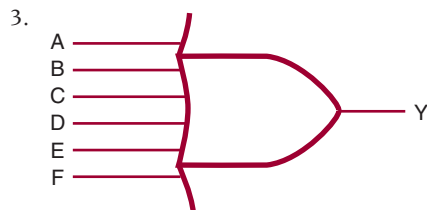
6. a. 0100 0001 0000 0110 = 4106
 b. 1001 0010 0100 0011 = 9243
 c. 0101 0110 0111 1000 = 5678

CHAPTER 33 BASIC LOGIC GATES



2.

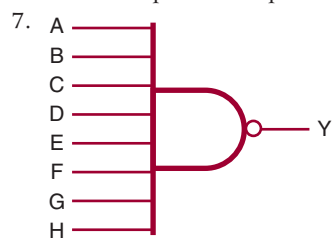
A	B	C	D	Y
0	0	0	0	0
1	0	0	0	0
0	1	0	0	0
1	1	0	0	0
0	0	1	0	0
1	0	1	0	0
0	1	1	0	0
1	1	1	0	0
0	0	0	1	0
1	0	0	1	0
0	1	0	1	0
1	1	0	1	0
0	0	1	1	0
1	0	1	1	0
0	1	1	1	0
1	1	1	1	1



4.

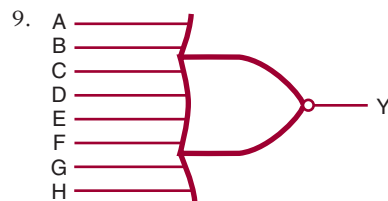
A	B	C	D	Y
0	0	0	0	0
1	0	0	0	1
0	1	0	0	1
1	1	0	0	1
0	0	1	0	1
1	0	1	0	1
0	1	1	0	1
1	1	1	0	1
0	0	0	1	1
1	0	0	1	1
0	1	0	1	1
1	1	0	1	1
0	0	1	1	1
1	0	1	1	1
0	1	1	1	1
1	1	1	1	1

5. The NOT circuit is used to perform inversion or complementation.
6. The circle or bubble is placed at the input for inversion of the input signal, and placed at the output for output inversion.



8.

A	B	C	D	Y
0	0	0	0	1
1	0	0	0	1
0	1	0	0	1
1	1	0	0	1
0	0	1	0	1
1	0	1	0	1
0	1	1	0	1
1	1	1	0	1
0	0	0	1	1
1	0	0	1	1
0	1	0	1	1
1	1	0	1	1
0	0	1	1	1
1	0	1	1	1
0	1	1	1	1
1	1	1	1	0



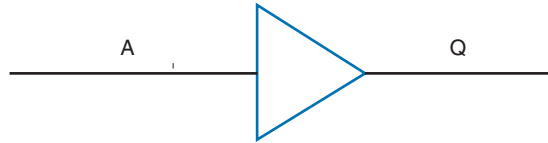
10.

A	B	C	D	Y
0	0	0	0	1
1	0	0	0	0
0	1	0	0	0
1	1	0	0	0
0	0	1	0	0
1	0	1	0	0
0	1	1	0	0
1	1	1	0	0
0	0	0	1	0
1	0	0	1	0
0	1	0	1	0
1	1	0	1	0
0	0	1	1	0
1	0	1	1	0
0	1	1	1	0
1	1	1	1	0

11. An XOR gate generates an output only when the inputs are different. If the inputs are both 0's or 1's, the output is a zero.

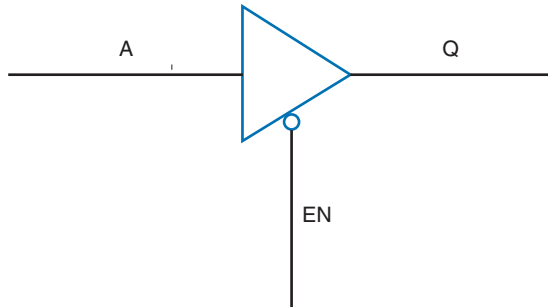
12. An XNOR gate has a maximum of two inputs.

13.



14. It is a special logic gate that isolates or provides a high current.

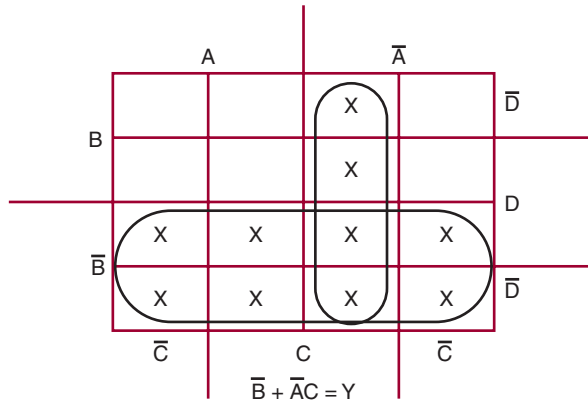
15.



CHAPTER 34 SIMPLIFYING LOGIC CIRCUITS

1. Use the Veitch diagram as follows:
 - a. Draw the diagram based on the number of variables.
 - b. Plot the logic functions by placing an X in each square representing a term.
 - c. Obtain the simplified logic function by looping adjacent groups of X's in groups of eight, four, or two. Continue to loop until all X's are included in a loop.
 - d. "OR" the loops with one term per loop.
 - e. Write the simplified expression.

2.



3. Use the Karnaugh maps as follows:
 - a. Draw the diagram based on the number of variables.
 - b. Plot the logic functions by placing a 1 in each square representing a term.
 - c. Obtain the simplified logic function by looping adjacent groups of 1's in groups of eight, four, or two.
 - d. "OR" the loops with one term per loop.
 - e. Write the simplified expression.

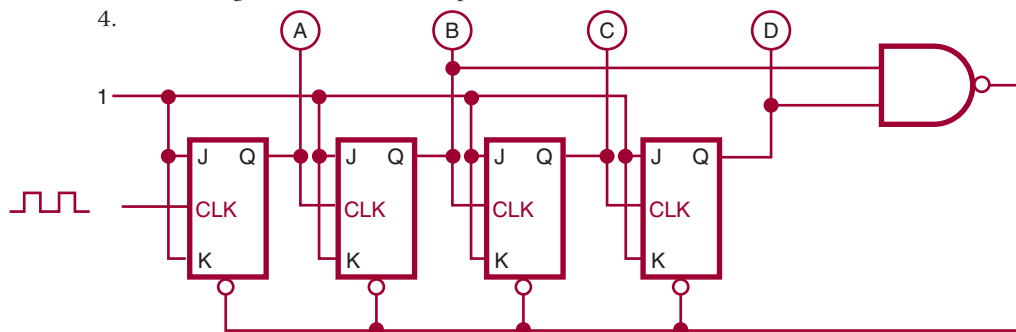
4.

	$\bar{C}\bar{D}$	$\bar{C}D$	CD	$C\bar{D}$
$\bar{A}\bar{B}$	1	1	1	1
$\bar{A}B$			1	1
AB				
$A\bar{B}$	1	1	1	1

$Y = \bar{B} + \bar{A}C$

CHAPTER 35 SEQUENTIAL LOGIC CIRCUITS

- To change the output of an RS flip-flop requires a high or 1 to be placed on the R input. This changes the state of the flip-flop to a 0 on the Q output and a 1 on the Q output.
- The major difference between the D flip-flop and the clocked RS flip-flop is that the D flip-flop has a single data input and a clock input.
- A counter is constructed of flip-flops connected in either an asynchronous or synchronous count mode. In the asynchronous mode, the Q or \bar{Q} output of the first stage is connected to the clock input of the next stage depending on whether the counter is counting up (Q) or down (\bar{Q}). In the synchronous mode, all the clock inputs of each of the stages are connected in parallel.

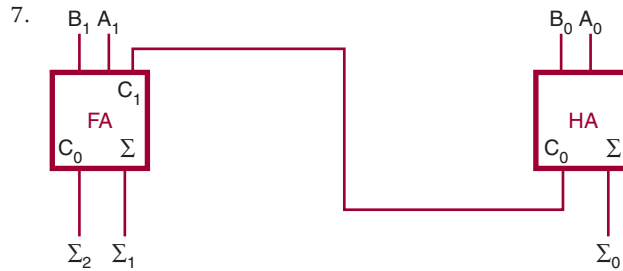


- A shift register is designed to store data temporarily and/or change its format. Data can be loaded into the shift register either serially or in parallel, and unloaded either serially or in parallel.
- Shift registers can be used to store data, for serial-to-parallel and parallel-to-serial data conversion, and to perform such arithmetic functions as division and multiplication.

CHAPTER 36 COMBINATIONAL LOGIC CIRCUITS

- Encoders allow encoding of keyboard inputs into binary outputs.
- A decimal-to-binary priority encoder is required for keyboard inputs.
- Decoders allow the processing of complex binary codes into a recognizable digit or character.
- Types of decoders include 1-of-10 decoders, 1-of-8 decoders, 1-of-16 decoders, and BCD-to-seven-segment decoders.
- Multiplexers are used to select and route one of several input signals to a single output.

6. Multiplexers can be used for data line selection and parallel-to-serial conversions.



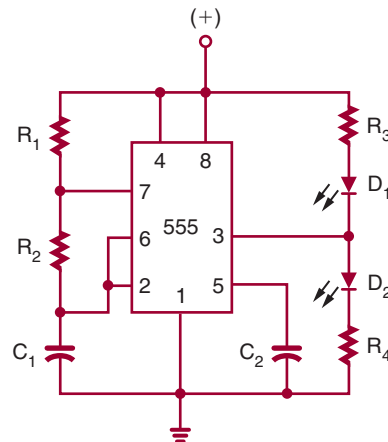
8. The half-adder accepts the two binary digits to be added and generates a sum and a carry. The carry is fed to the next stage and added to the two binary digits, generating a sum and a carry. The answer is the result of the carry and the two sum outputs.

CHAPTER 37 MICROCOMPUTER BASICS

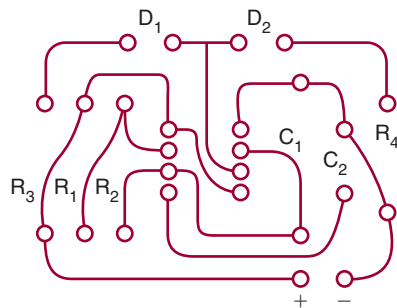
1. A computer consists of a control unit, an arithmetic logic unit (ALU), memory, and an input/output unit (I/O). The control unit decodes the instructions and generates the necessary pulses to carry out the specified function. The arithmetic logic unit performs all the math logic and decision-making operations. Memory is where the programs and data are stored. The input/output unit allows data to be entered into and removed from the computer (see Figure 37–1).
2. An *interrupt* signal from an external device lets the computer know that it would like data or wants to send data.
3. A microprocessor is part of a microcomputer. It consists of four basic parts: registers, arithmetic logic unit, timing and control circuitry, and decoding circuitry.
4. The microprocessor performs the control functions and handles the math logic and decision making for a microcomputer.
5. A microcontroller includes a microprocessor, memory, and input/output interfacing. It is a stand-alone system.

CHAPTER 38 FABRICATING A PRINTED CIRCUIT BOARD

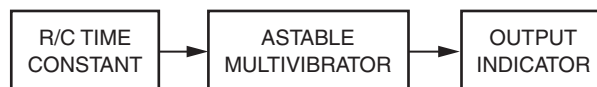
1. A printed circuit board supports the copper traces on an insulating base material.
- 2.



3.



4.

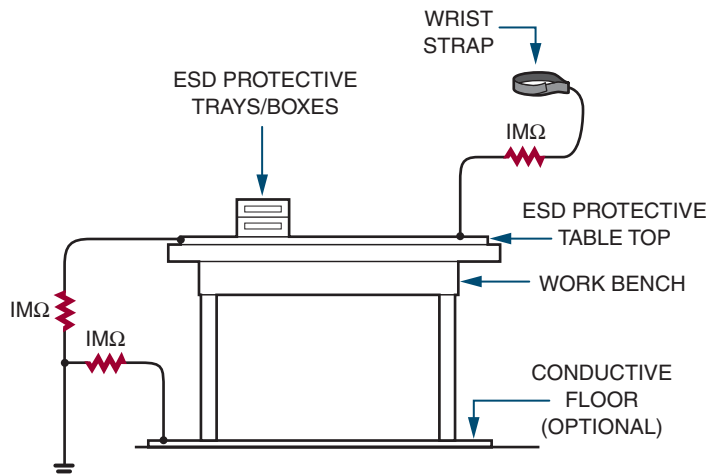


5. Storage: Keep away from sources of ignition. Store in a cool, dry, well-ventilated area, away from incompatible substances.
 Heating: Do not expose container to heat or flame or temperatures over 40°C

CHAPTER 39 ELECTRONIC TOOLS AND APPLICATIONS

- ICs can be removed from a printed circuit board with a small, flat-blade screwdriver or an IC chip remover.
- Oscilloscope.
- Temperature-controlled soldering iron.
- Chisel tip.
- A soldering iron that is resting in a stand to remove excess heat.

6.



7. Personal ESD guidelines:

- Wear wrist strap to ground body.
- Check data sheet for ESD instructions.
- Discharge the package of ESD device.
- Minimize handling of ESD device.
- Avoid physical movement when handling ESD device.
- Avoid touching leads when handling ESD device.

- g. Do not allow ESD device to come in contact with ungrounded materials.
- h. Always touch the surface where an ESD device rests prior to handling to discharge.
- i. When handling ESD devices avoid touching materials that can cause a static charge.
- j. Use a soldering iron with a ground tip.
- k. Avoid using plastic solder suckers.
- l. Ground test equipment tips prior to probing an ESD device.

CHAPTER 40 BASIC TROUBLESHOOTING

1. Isolation transformer.
2. Troubleshooting technique includes:
 - a. Check the circuit over thoroughly before applying power.
 - b. Apply power and determine if the circuit is operating properly.
 - c. Uses senses to troubleshoot defective circuit.
 - d. Expose circuit to the operating environment to determine proper operation.
3. Test equipment for effective troubleshooting includes:
 - a. Ohmmeter
 - b. Voltmeter
 - c. Ammeter
 - d. Oscilloscope
4. A short circuit has zero ohms resistance and a open circuit has an infinite resistance.
5. A schematic diagram will show voltage measurements and waveforms in a circuit.

This page intentionally left blank

APPENDICES

APPENDIX 1

Electronics Abbreviations

TERM	ABBREVIATION	TERM	ABBREVIATION
Alpha	α	Kilo	k
Alternating Current	ac, AC	Mega	M
Ampere	A, amp	Micro	μ
Beta	β	Milli	m
Capacitance	C	Nano	n
Capacitive Reactance	X_c	Ohm	Ω
Charge	Q	Peak-to-Peak	p-p
Conductance	G	Period	T
Coulomb	C	Pico	p
Current	I, i	Power	P
Cycles per Second	Hz	Reactance	X
Degrees Celsius	$^{\circ}\text{C}$	Resistance	R, r
Degrees Fahrenheit	$^{\circ}\text{F}$	Resonant Frequency	f_r
Direct Current	dc, DC	Root Mean Square	rms
Electromotive Force	emf, E, e	Second	s
Farad	F	Siemens	S
Frequency	f	Time	t
Giga	G	Var	var
Henry	H	Volt	V, v
Hertz	Hz	Volt-Ampere	VA
Impedance	Z	Wavelength	λ
Inductance	L	Watt	W
Inductive Reactance	X_L		

Group IA																	VIII																												
1 H Hydrogen											2 He Helium																																		
IIA												III B	IV B	VB	VIB	VII B	VIII																												
3 Li Lithium	4 Be Beryllium											5 B Boron	6 C Carbon	7 N Nitrogen	8 O Oxygen	9 F Fluorine	10 Ne Neon																												
IIA												III B	IV B	VB	VIB	VII B	VIII																												
11 Na Sodium	12 Mg Magnesium	IIIA	IVA	VA	VIA	VIIA	I-----VIII-----I		IB	IIB	III B	IV B	VB	VIB	VII B	VIII																													
13 Al Aluminum	14 Si Silicon	15 P Phosphorus	16 S Sulfur	17 Cl Chlorine	18 Ar Argon																																								
19 K Potassium	20 Ca Calcium	21 Sc Scandium	22 Ti Titanium	23 V Vanadium	24 Cr Chromium	25 Mn Manganese	26 Fe Iron	27 Co Cobalt	28 Ni Nickel	29 Cu Copper	30 Zn Zinc	31 Ga Gallium	32 Ge Germanium	33 As Arsenic	34 Se Selenium	35 Br Bromine	36 Kr Krypton																												
37 Rb Rubidium	38 Sr Strontium	39 Y Yttrium	40 Zr Zirconium	41 Nb Niobium	42 Mo Molybdenum	43 Tc Technetium	44 Ru Ruthenium	45 Rh Rhodium	46 Pd Palladium	47 Ag Silver	48 Cd Cadmium	49 In Indium	50 Sn Tin	51 Sb Antimony	52 Te Tellurium	53 I Iodine	54 Xe Xenon																												
55 Cs Cesium	56 Ba Barium	57 La Lanthanum	72 Hf Hafnium	73 Ta Tantalum	74 W Tungsten	75 Re Rhenium	76 Os Osmium	77 Ir Iridium	78 Pt Platinum	79 Au Gold	80 Hg Mercury	81 Tl Thallium	82 Pb Lead	83 Bi Bismuth	84 Po Polonium	85 At Astatine	86 Rn Radon																												
87 Fr Francium	88 Ra Radium	89 Ac Actinium	104 Unq (Unniquadium)	105 Unp (Unnipientium)	106 Unh (Unnhexium)																																								
<table border="1"> <tbody> <tr> <td>58 Ce Cesium</td> <td>59 Pr Praseodymium</td> <td>60 Nd Neodymium</td> <td>61 Pm Promethium</td> <td>62 Sm Samarium</td> <td>63 Eu Europium</td> <td>64 Gd Gadolinium</td> <td>65 Tb Terbium</td> <td>66 Dy Dysprosium</td> <td>67 Ho Holmium</td> <td>68 Er Erbium</td> <td>69 Tm Thulium</td> <td>70 Yb Ytterbium</td> <td>71 Lu Lutetium</td> </tr> <tr> <td>90 Th Thorium</td> <td>91 Pa Protactinium</td> <td>92 U Uranium</td> <td>93 Np Neptunium</td> <td>94 Pu Plutonium</td> <td>95 Am Americium</td> <td>96 Cm Curium</td> <td>97 Bk Berkelium</td> <td>98 Cf Californium</td> <td>99 Es Einsteinium</td> <td>100 Fm Fermium</td> <td>101 Md Mendelevium</td> <td>102 No Nobelium</td> <td>103 Lr Lawrencium</td> </tr> </tbody> </table>																		58 Ce Cesium	59 Pr Praseodymium	60 Nd Neodymium	61 Pm Promethium	62 Sm Samarium	63 Eu Europium	64 Gd Gadolinium	65 Tb Terbium	66 Dy Dysprosium	67 Ho Holmium	68 Er Erbium	69 Tm Thulium	70 Yb Ytterbium	71 Lu Lutetium	90 Th Thorium	91 Pa Protactinium	92 U Uranium	93 Np Neptunium	94 Pu Plutonium	95 Am Americium	96 Cm Curium	97 Bk Berkelium	98 Cf Californium	99 Es Einsteinium	100 Fm Fermium	101 Md Mendelevium	102 No Nobelium	103 Lr Lawrencium
58 Ce Cesium	59 Pr Praseodymium	60 Nd Neodymium	61 Pm Promethium	62 Sm Samarium	63 Eu Europium	64 Gd Gadolinium	65 Tb Terbium	66 Dy Dysprosium	67 Ho Holmium	68 Er Erbium	69 Tm Thulium	70 Yb Ytterbium	71 Lu Lutetium																																
90 Th Thorium	91 Pa Protactinium	92 U Uranium	93 Np Neptunium	94 Pu Plutonium	95 Am Americium	96 Cm Curium	97 Bk Berkelium	98 Cf Californium	99 Es Einsteinium	100 Fm Fermium	101 Md Mendelevium	102 No Nobelium	103 Lr Lawrencium																																

APPENDIX 2

Periodic Table of Elements

APPENDIX 3

The Greek Alphabet

GREEK LETTER		GREEK NAME
A	α	alpha
B	β	beta
Γ	γ	gamma
Δ	δ	delta
E	ε	epsilon
Z	ζ	zeta
H	η	eta
Θ	θ	theta
I	ι	iota
K	κ	kappa
Λ	λ	lambda
M	μ	mu
N	ν	nu
Ξ	ξ	xi
O	ο	omicron
Π	π	pi
P	ρ	rho
Σ	σ	sigma
T	τ	tau
Υ	υ	upsilon
Φ	φ	phi
X	χ	chi
Ψ	ψ	psi
Ω	ω	omega

APPENDIX 4

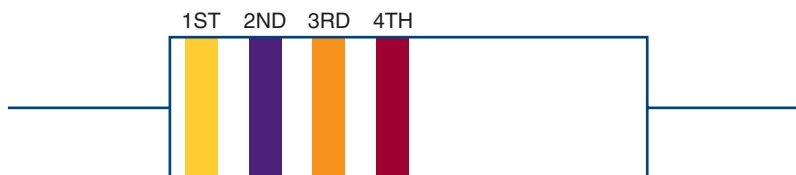
Metric Prefixes Used in Electronics

PREFIX	SYMBOL	MULTIPLICATION FACTOR	
Yotta-	Y	10^{24}	1,000,000,000,000,000,000,000,000
Zetta-	Z	10^{21}	1,000,000,000,000,000,000,000
exa-	E	10^{18}	1,000,000,000,000,000,000
peta-	P	10^{15}	1,000,000,000,000,000
tera-	T	10^{12}	1,000,000,000,000
giga-	G	10^9	1,000,000,000
mega-	M	10^6	1,000,000
kilo-	k	10^3	1,000
hecto-	h	10^2	100
deka-	da	10^0	10
deci-	d	10^{-1}	0.1
centi-	c	10^{-2}	0.01
milli-	m	10^{-3}	0.001
micro-	μ	10^{-6}	0.000,001
nano-	n	10^{-9}	0.000,000,001
pico-	p	10^{-12}	0.000,000,000,001
femto-	f	10^{-15}	0.000,000,000,000,001
atto-	a	10^{-18}	0.000,000,000,000,000,001
zepto-	z	10^{-21}	0.000,000,000,000,000,000,001
yocto-	y	10^{-24}	0.000,000,000,000,000,000,000,001

APPENDIX 5

Resistor Color Codes

		TOLERANCE	
Black	0		
Brown	1	Gray	0.05%
Red	2	Violet	0.10%
Orange	3	Blue	0.25%
Yellow	4	Green	0.5%
Green	5	Brown	1%
Blue	6	Red	2%
Violet	7	Gold	5%
Gray	8	Silver	10%
White	9	None	20%



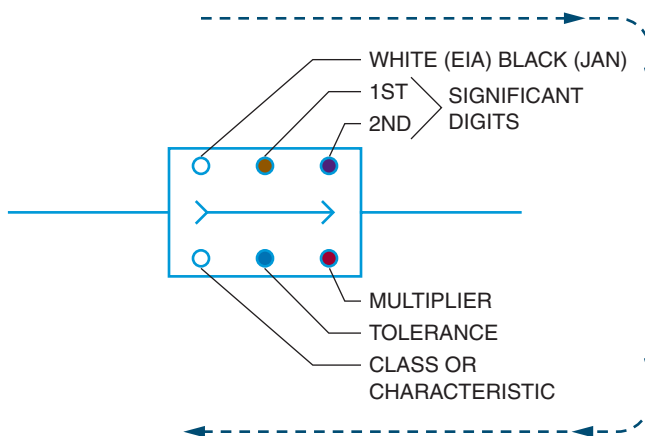
COLOR	1ST BAND 1ST DIGIT	2ND BAND 2ND DIGIT	3RD BAND NUMBER OF ZEROS	4TH BAND TOLERANCE
Black	0	0	—	—
Brown	1	1	0	1%
Red	2	2	00	2%
Orange	3	3	000	—
Yellow	4	4	0000	—
Green	5	5	00000	0.5%
Blue	6	6	000000	0.25%
Violet	7	7		0.10%
Gray	8	8		0.05%
White	9	9		—
Gold	—	—	x.1	5%
Silver	—	—	x.01	10%
None	—	—	—	20%

APPENDIX 6

Capacitor Color Code

COLOR	DIGIT	MULTIPLIER	TOLERANCE
Black	0	1	20%
Brown	1	10	1%
Red	2	100	2%
Orange	3	1000	3%
Yellow	4	10000	4%
Green	5	100000	5%
Blue	6	1000000	6%
Violet	7		7%
Gray	8		8%
White	9		9%
Gold		0.1	
Silver		0.01	10%
Body			20%

Note: EIA stands for Electronic Industries and Association, and JAN stands for Joint Army-Navy, a military standard.

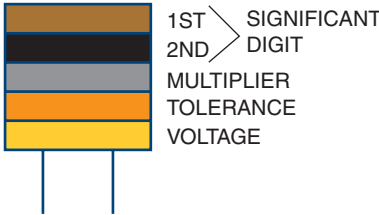
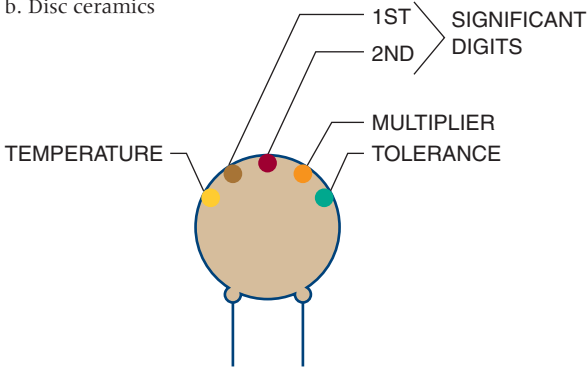


a. Molded mica

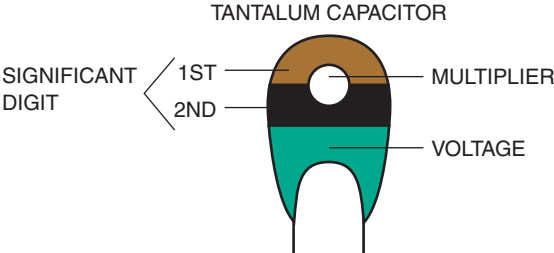
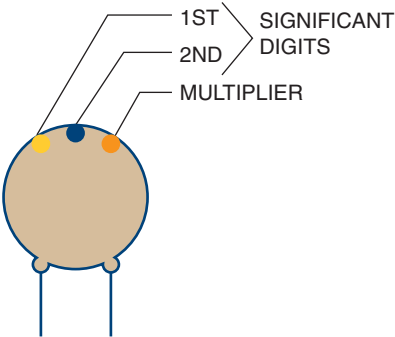
APPENDIX 6

Capacitor Color Code (Continued)

b. Disc ceramics

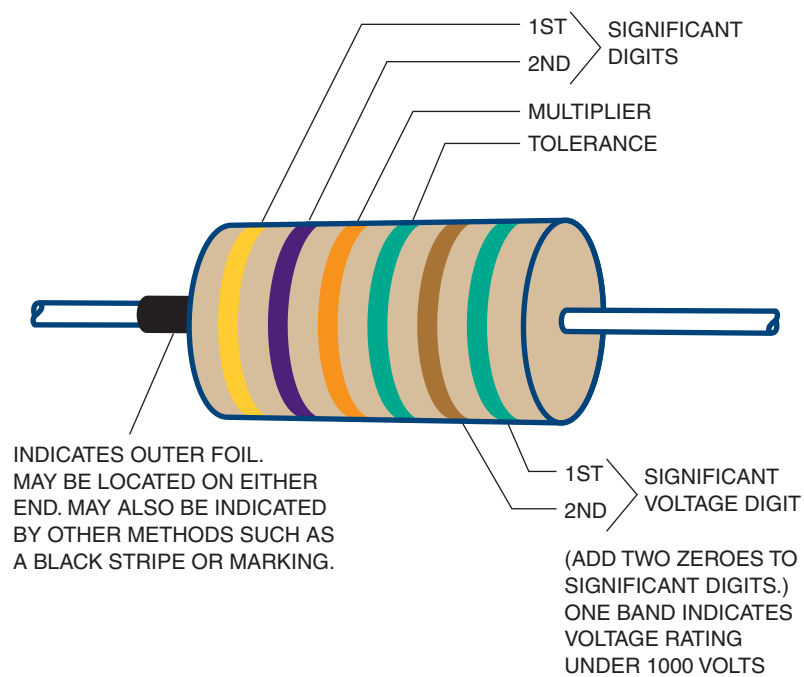


c. Axial Foil



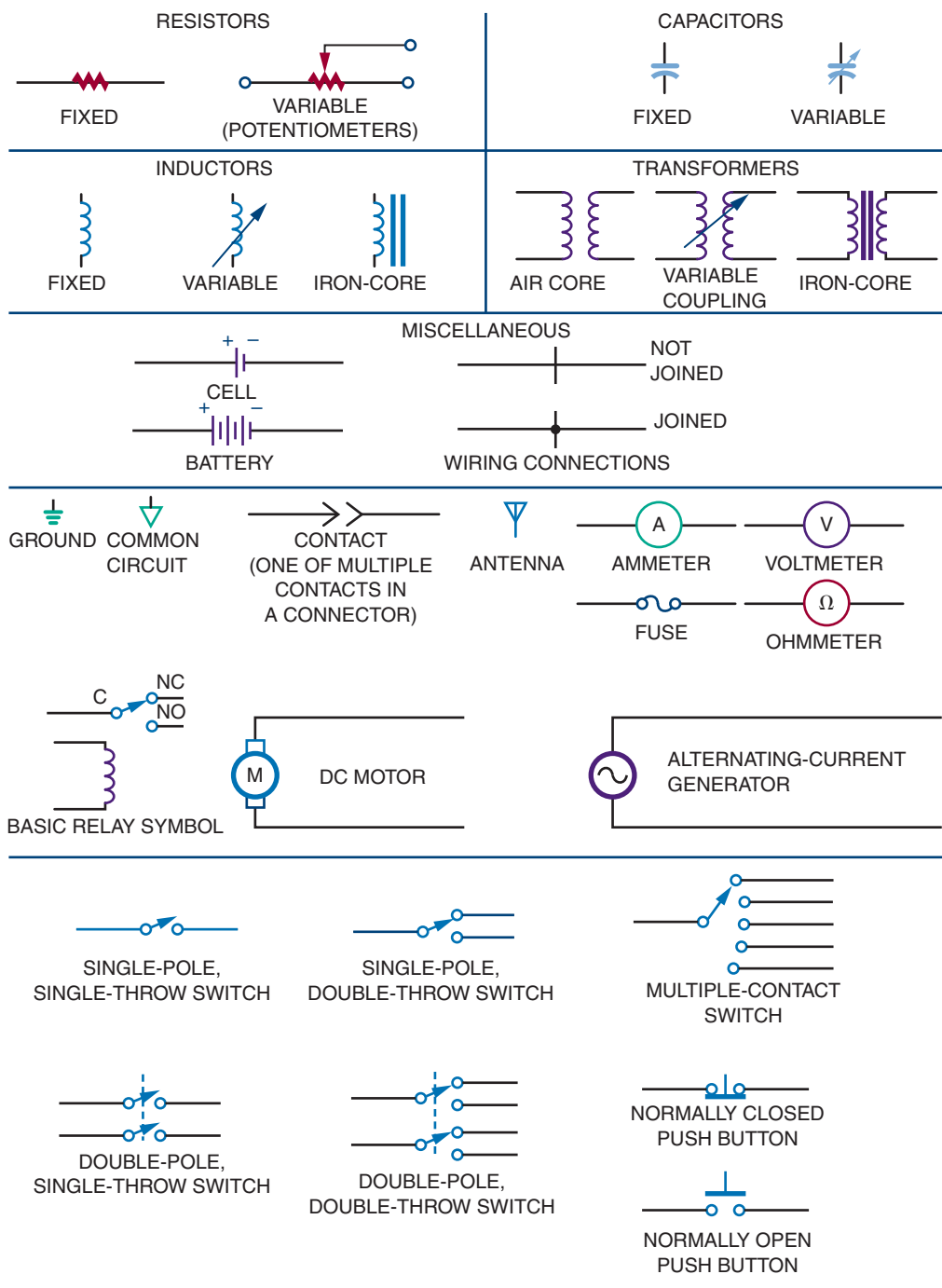
APPENDIX 6

Capacitor Color Code (Continued)






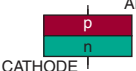
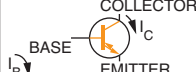
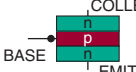
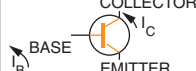
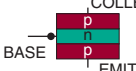
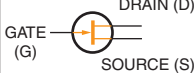
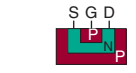
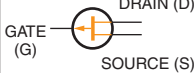

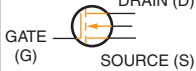


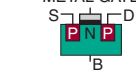
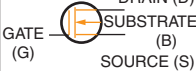
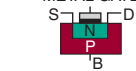

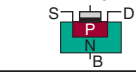



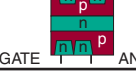
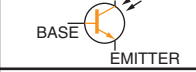
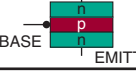

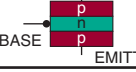

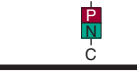
APPENDIX 7

Electronics Symbols



APPENDIX 8

Semiconductor Schematic Symbols

NAME OF DEVICE	CIRCUIT SYMBOL	COMMONLY USED JUNCTION SCHEMATIC	MAJOR APPLICATIONS
DIODE			Rectification Blocking Detecting Steering
ZENER DIODE			Voltage Regulation
N-P-N TRANSISTOR			Amplification Switching Oscillation
P-N-P TRANSISTOR			Amplification Switching Oscillation
N-CHANNEL JFET			Amplification Switching Oscillation
P-CHANNEL JFET			Amplification Switching Oscillation
ENHANCEMENT N-CHANNEL MOSFET			Switching Digital Applications
ENHANCEMENT N-CHANNEL MOSFET			Switching Digital Applications
DEPLETION N-CHANNEL MOSFET			Amplification Switching
DEPLETION P-CHANNEL MOSFET			Amplification Switching
SILICON CONTROLLED RECTIFIER (SCR)			Power Switching Phase Control Inverters Choppers
TRIAC			Ac Switching Phase Control Relay Replacement
PHOTO TRANSISTOR			Tape Readers Card Readers Position Sensor Tachometers
DIAC			Trigger
LIGHT EMITTING DIODE (LED)			Indicator Light Source Optical Coupler Displays

APPENDIX 9

Digital Logic Symbols

LOGIC FUNCTION	AMERICAN (MIL/ANSI) SYMBOL	COMMON GERMAN SYMBOL	INTERNATIONAL ELECTROTECHNICAL COMMISSION (IEC) SYMBOL	BRITISH (BS3939) SYMBOL
BUFFER				
INVERTER (NOT GATE)				
2-INPUT AND GATE				
2-INPUT OR GATE				
2-INPUT NAND GATE				
2-INPUT NOR GATE				
2-INPUT (EXCLUSIVE OR) X-OR GATE				
2-INPUT (EXCLUSIVE NOR) X-NOR GATE				

APPENDIX 10

DC and AC Circuit Formulas

	Series	Parallel
Resistance	$R_T = R_1 + R_2 + R_3 + \dots R_n$	$\frac{1}{R_T} = \frac{1}{R_1} + \frac{1}{R_2} + \frac{1}{R_3} + \dots \frac{1}{R_n}$
Capacitance	$\frac{1}{C_T} = \frac{1}{C_1} + \frac{1}{C_2} + \frac{1}{C_3} + \dots \frac{1}{C_n}$	$C_T = C_1 + C_2 + C_3 + \dots C_n$
Inductance	$L_T = L_1 + L_2 + L_3 + \dots L_n$	$\frac{1}{L_T} = \frac{1}{L_1} + \frac{1}{L_2} + \frac{1}{L_3} + \dots \frac{1}{L_n}$
Impedance	$Z_T = Z_1 + Z_2 + Z_3 + \dots Z_n$	$\frac{1}{Z_T} = \frac{1}{Z_1} + \frac{1}{Z_2} + \frac{1}{Z_3} + \dots \frac{1}{Z_n}$
Voltage	$E_T = E_1 + E_2 + E_3 + \dots E_n$	$E_T = E_1 = E_2 = E_3 = \dots E_n$
Current	$I_T = I_1 = I_2 = I_3 = \dots I_n$	$I_T = I_1 + I_2 + I_3 + \dots I_n$
Power	$P_T = P_1 + P_2 + P_3 + \dots P_n$	$P_T = P_1 + P_2 + P_3 + \dots P_n$

Formulas

Ohm's Law

$$I = \frac{E}{R}$$

Conductance

$$G = \frac{1}{R}$$

Impedance

$$I = \frac{E}{Z}$$

Reactance

$$X_L = 2\pi fL$$

$$X_C = \frac{1}{2\pi fC}$$

Power

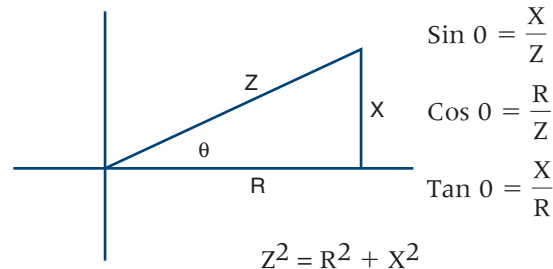
$$P = IE$$

Resonance

$$f_R = \frac{1}{2\pi\sqrt{LC}}$$

AC Values Chart

	Peak	RMS	AVG
Peak	X	$0.707 \times \text{Peak}$	$0.637 \times \text{Peak}$
RMS	$1.41 \times \text{RMS}$	X	$0.9 \times \text{RMS}$
AVG	$1.57 \times \text{AVG}$	$1.11 \times \text{AVG}$	X

Miscellaneous**Conversion**

Rectangular to Polar

$$R = \sqrt{X^2 + Y^2} \text{ and } \theta = \text{Arctan} \frac{Y}{X}$$

Polar to Rectangular

$$X = R \text{ Cos } \theta \text{ and } Y = R \text{ Sin } \theta$$

Page numbers in italics refers to figures.

A

- A, 7, 11
- Abbreviations, 503
- AC, 18, 125
- AC circuits, 123–171
 - AC generator, 126–127
 - AC values, 128–129
 - capacitive circuits, 148–154
 - formulas, 514
 - inductive circuits, 155–156
 - measurements, 133–141. *See also* AC measurements
 - nonsinusoidal waves, 130–131
 - parallel circuits, 144
 - reactance, 161–166
 - resistive circuits, 142–147
 - resonance circuits, 169
 - series circuits, 143–144
 - transformer, 171–178
- AC generator, 104–105, 126–127
- AC measurements, 133–141
 - bode plotter, 140–141
 - frequency counter, 139–140
 - meters, 133–136
 - oscilloscope, 136–139
- AC meters, 133–136
- AC resistive circuit, 142–147, 162
- AC values, 128–129
- AC values chart, 514
- Acceptor atom, 188
- Accumulator, 373, 376
- Active filter, 291
- Active material, 185
- Adder, 363–365
- Air-core inductor, 112, 112
- Alcohol and flux bottle, 419
- Alkaline cell, 22, 23
- Alloyed junction method, 196
- Alternating current (AC), 18, 125
- Alternating current (AC) circuits. *See* AC circuits
- Alternating current (AC) generator, 104–105, 126–127
- Alternation, 126–127
- Alternator, 105
- ALU, 372, 373, 373
- Ammeter, 63, 65–67, 444, 446, 446
- Ammeter shunt, 66
- Ammonia persulphate, 403
- Ampere (A), 7, 11
- Ampère, André Marie, 7
- Ampere-hour, 23
- Amplifier. *See* Amplification
- Amplifier circuit input-output relationships, 269
- Amplification, 267–292
 - audio amplifier, 280–282
 - bias, 269–273
 - common-base circuit, 268–269
 - common-collector circuit, 268–269
 - common-emitter circuit, 268–269
 - coupling, 273–275
 - DC amplifier, 277–279
 - IF amplifier, 286, 287
 - op-amp, 287–291
 - RF amplifier, 285–286
 - video amplifier, 282–284
- Amplifier biasing, 269–273
- Amplifier coupling, 273–275
- Amplitude, 128
- Analog meter, 62, 62
- Analog multimeter (VOM), 421
- Analog multiplexer, 360
- Analog oscilloscope, 422
- AND gate, 321–322
- Anode, 195
- Answers, self-test, 467–501
- Antistatic work station, 441
- Aperture file, 402
- Apparent power, 167
- Arithmetic circuits, 363–368
- Arithmetic instructions, 377
- Arithmetic logic circuitry, 373
- Arithmetic logic unit (ALU), 372, 373, 373
- Armature, 105, 127
- Artificial magnet, 97

Astable multivibrator, 299
Asynchronous, 342
Asynchronous counter, 343
Atom, 4, 5
Atomic number, 5
Atomic weight, 5
Audio amplifier, 280–282
Autorouter, 401
Autotransformer, 176
Axial capacitor lead, 118

B

Band-pass filter, 291, 291
Barnhart, Gemma, 124
Base, 205
Basic Stamp, 378
Battery, 21
BCD code, 319
BCD-to-seven-segment decoder, 360, 361
BCD up-down counter, 345, 348
Bias
 amplifier, 269–273
 clipping circuit, 307, 308
 depletion MOSFET, 217
 enhancement MOSFET, 219
 forward, 193
 LED, 244–245
 PN junction diode, 193–194
 reverse, 194
 SCR, 225
 transistor, 207–208
 voltage divider, 88
Bias voltage, 193
Biased series diode clipping circuit, 307
Biased shunt diode clipping circuit, 308
Bidirectional trigger diode (DIAC), 228
Binary and decimal conversion, 317–318
Binary-coded decimal (BCD) code, 319
Binary number system, 315–316
Binary-to-decimal decoder, 358
Binary-to-seven-segment display decoder, 359–360, 361
Bipolar memory, 352
Bipolar transistor, 204–212
Bistable action, 223
Bistable multivibrator, 310
Bit, 315
Block diagram, 447, 448
Blocking oscillator, 298, 298–299

Bode, H. W., 140
Bode plotter, 140–141
Bottom (solder side), 387
Branch, 41
Breadboarding, 395–396
Breakdown voltage, 199
Bridge rectifier, 252
Bridge rectifier circuit, 252
Bridging, 433
Bristle and acid brushes, 416
Buffer, 327
Burner, 353
Butler oscillator, 296–297, 297
Bypass capacitor, 271
Byte, 351

C

C, 7, 11
CAD, 395
Cadmium selenide (CdSe), 240
Cadmium sulfide (CdS), 240
Capacitance, 116–117, 514
Capacitive AC circuits, 148–154
Capacitive reactance, 149–150
Capacitor color code, 508–510
Capacitor filter, 254
Carbon composition resistor, 34, 34
Career profile
 airborne communications system operator, 2
 CEO, Alpha Data Corporation, 384
 college instructor, 314
 electronic assembler, 124
 TV station manager, 182
 U.S. Air Force, 248
Cascaded RC phase-shift network, 153, 153
Cathode, 195
Cathode-ray tube (CRT), 137, 137
CdS, 240
CdSE, 240
Cell, 18, 21–23
Central processing unit (CPU), 372
Ceramic disk capacitor, 118, 119
Channel, 214
Choke, 112
Christie, Samuel Hunter, 93
Circuit breaker, 265, 265
Circuit panel box, 29
Circuit protection devices, 263–265

Clamp-on AC meter, 135
Clamping circuit, 309
Clapp oscillator, 295, 295, 296
Class A amplifier, 272
Class AB amplifier, 272
Class B amplifier, 272
Class C amplifier, 272
Clip-on ammeter, 67
Clipping circuit, 307–308
Clocked flip-flop, 339–340
Closed circuit, 50, 68
Closed-loop mode, 288
CNC machine, 403, 404
Coefficient of coupling, 171
Cold solder connection, 433
Collector, 205
Collector feedback circuit, 270
Color-coded system, 401
Colpitts crystal oscillator, 296
Colpitts oscillator, 295, 295
Combinational logic circuits, 356–370
Commercial spray etchers, 404
Common-base circuit, 268–269
Common-collector circuit, 268–269
Common-emitter circuit, 268–269
Common-mode rejection, 288
Commutator, 105
Comparator, 366–367
Compare instructions, 377
Complementary DC amplifier, 278, 278
Complementary push-pull amplifier, 280–281, 281
Complementing, 377
Component lead former tool, 420
Component side, 387
Compound, 4
Compute monitor, 283
Computer-aided design (CAD), 395
Computer memory, 351–354, 374
Condition-code register, 376
Conductance (G), 32, 514
Conductor, 6, 8, 50
Conformal coatings, 434–435
Connecting cells and batteries, 24–26
Continuity test, 68
Control unit, 372, 373
Controller, 378
Copper, 50
Coulomb, Charles, 11
Coulomb (C), 7, 11

Counter, 342–345, 346, 347, 348
Counter emf, 111, 155
Coupling, 152–153, 273–275
Coupling network, 152–153, 153
Covalent bonding, 185
CPU, 372
Crowbar overprotection circuit, 263, 263–264
Crystal microphone, 20
Crystal oscillator, 295–297
Crystal shunt-fed Hartley oscillator, 296
Crystals, 295–296
Current (I), 7, 11
Current flow, 11–13
Cut-off frequency, 159
Cycle, 127

D

D flip-flop, 340–341
Darlington arrangement, 278, 279
Data movement instructions, 376–377, 377
DC, 18, 125
DC amplifier, 277–279
DC and AC circuit formulas, 514
DC circuits, 1–122
 capacitance, 116–121
 current, 10–16
 electric circuit, 49–51
 formulas, 514
 inductance, 110–115
 Kirchhoff's current law, 57
 Kirchhoff's voltage law, 58
 magnetism, 96–109. *See also* Magnetism
 measurements, 61–74. *See also* DC measurements
 Ohm's law, 51–56
 parallel circuit, 82–84
 power, 75–79
 resistance, 31–48
 series circuit, 80–82
 series-parallel circuit, 84–88
 voltage, 17–30
 voltage divider, 88–93
 Wheatstone bridge, 93–94
DC generator, 105–106
DC measurements, 61–74
 ammeter, 63, 65–67
 analog meter, 62
 digital meter, 62
 measuring current, 65–67

- measuring resistance, 68–69
 - measuring voltage, 67–68
 - multimeter, 64–65
 - ohmmeter, 63, 68–69
 - reading meter scales, 70–72
 - voltmeter, 63, 67–68
- DC motor, 107–108
- DC reference level, 308
- DC resistive circuit, 162
- DC restorer, 309
- Decade counter, 343, 348
- Decimal-to-binary encoder, 356, 357
- Decimal-to-binary priority encoder, 356–357, 357, 358
- Decision-making logic circuits, 321
- Decoder, 357–360
- Decoupling network, 152, 152
- Defects. *See* Troubleshooting
- Definitions (glossary), 455–465
- Defluxer, 431
- Degenerative feedback, 270, 297
- Degree of rotation, 128
- DeJesus, Pablo, 248
- Delay flip-flop, 341
- Depletion mode devices, 216
- Depletion MOSFET, 216–218
- Derating factor, 200
- Desoldering, 431
- Desoldering braid, 431, 431
- Desoldering bulb, 431, 432
- Desoldering pump, 431, 432
- DIAC, 228
- Diagonal cutters, 417
- Dielectric, 116
- Dielectric constant, 118
- Difference amplifier, 291, 291
- Difference of potential, 7
- Differential amplifier, 279, 279
- Differentiator, 306
- Differentiator circuit, 306
- Diffused junction method, 196
- Digital computer, 371. *See also* Microcomputer basics
- Digital electronic circuits, 313–381
 - adder, 363–365
 - arithmetic circuits, 363–368
 - BCD code, 319
 - binary and decimal conversion, 317–318
 - binary number system, 315–316
 - buffer, 327
 - combinational logic circuits, 356–370
 - comparator, 366–367
 - counter, 342–345, 346, 347, 348
 - decoder, 357–360
 - encoder, 356–357
 - exclusive NOR gate, 326
 - exclusive OR gate, 325–326
 - flip-flop, 339–341
 - AND gate, 321–322
 - Karnaugh diagram, 333–336
 - logic gates, 321–327
 - logic symbols, 513
 - memory, 351–354
 - microcomputer basics, 371–381
 - multiplexer, 360–363
 - NOR gate, 324
 - NOT gate, 323–324
 - OR gate, 322
 - PLDs, 368–369
 - sequential logic circuits, 338–355
 - shift register, 345, 349–351
 - subtractor, 365–366
 - Veitch diagram, 330–333
 - XNOR gate, 326
 - XOR gate, 325–326
- Digital logic symbols, 513
- Digital meter, 62, 62
- Digital multimeter (DMM), 64–65, 422
- Digital multiplexer, 360
- Diode
 - defined, 192
 - PN junction, 191–198
 - zener, 199–203
- Diode biasing, 193–194
- Diode clamper, 309, 309
- Diode construction techniques, 195–197
- DIP, 236
- Direct-coupled amplifier, 277–279
- Direct coupling, 275, 275
- Direct current circuits. *See* DC circuits
- Direct current (DC), 18, 125
- Direct current (DC) generator, 105–106
- Disturbed solder connection, 433
- DMM, 64–65, 422
- Domain, 98
- Donor atom, 187
- Doorbell, 106
- Doped semiconductor, 187–189
- Doping, 187, 195
- Double-sided boards, 385, 389

Double trace layers, 385
Drain, 214
Drain current, 214
Drain-to-source voltage, 215
DRAM, 353
Drill file, 402
Dry cell, 21
Dual-inline package (DIP), 236
Dual-polarity voltage regulator, 260
Dummer, W. A., 233
Duty cycle, 304
Dynamic RAM (DRAM), 353

E

Edison, Thomas, 125
EEPROM, 354
Effective value, 128–129
EIA color code, 37
Eight-input multiplexer, 362
8051, 378
8421 BCD-to-seven segment decoder, 359
8421 code, 319
Electric circuit, 49–51
Electric current, 11–13
Electric power rate, 75
Electrical grounding, 28–29
Electrical measurements. *See* AC measurements; DC measurements
Electrical shock, 435
Electrically erasable PROM (EEPROM), 354
Electrolyte, 118
Electrolytic capacitor, 118, 118
Electromagnet, 97, 101
Electromagnetic induction, 102, 171
Electromotive force (emf), 7, 110
Electron, 5, 184
Electron-hole pair, 186
Electronic counter, 140
Electronic Industries Association (EIA) color code, 37
Electronic test equipment, 421–424
Electronics abbreviations, 503
Electronics symbols, 511. *See also* Schematic symbols
Electronics technician toolbox, 416–421
Electrostatic discharge (ESD), 437, 438, 438–441
Element, 4
ELI, 156
emf, 7, 110
Emitter, 205

Emitter feedback circuit, 271
Emitter-follower regulator, 258
EN line, 327
Encoder, 356–357
Encoding, 356
Enhancement mode devices, 216
Enhancement MOSFET, 218–220
Equivalent DIAC, 228
Equivalent SCR, 224
Equivalent TRIAC, 226
Error voltage, 258
ESD, 437, 438, 438–441
Etchant, 387
Etched PCB, 403–405
Evaporation process, 235
Even harmonics, 131
Exclusive NOR gate, 326
Exclusive OR gate, 325–326

F

F, 117
Fall time, 305, 305
Farad (F), 117
Faraday's law, 103
Feedback regulator, 258
Feedback series regulator, 258–260
Ferric chloride, 403, 409–411
Ferromagnetic materials, 98
FET, 213–222. *See also* Field effect transistor (FET)
Field, 105
Field effect transistor (FET), 213–222
 JFET, 213–216
 MOSFET, 216–220
 testing, 220–221
Film resistor, 35, 35
Filter
 capacitive AC circuits, 151–153
 circuits, 253–255
 defined, 151, 253
 inductive AC circuits, 158–159
Filter capacitor, 254
Filter circuits, 253–255
First harmonic, 303
555 timer, 299–300, 300
Fixed capacitor, 117
Fixed inductors, 111
Fixed resistor, 33
Fixed voltage regulator, 260

Flag bit, 376
Flat nose pliers, 417
Flat-pack integrated circuit, 237
Flat response, 282
Flip flop, 310, 310
Flip-flop, 339–341
Flip-flop circuit, 339
Flux cleaner, 431
Flux lines, 98
Formulas, 514
Forward bias, 193
Forward-biased LED, 244
Forward voltage drop, 193
Four-bit comparator, 367
Four-bit latch, 341
Four-bit parallel adder, 365, 365
Four-bit subtractor, 366
4-line-to-10-line decoder, 358
Four-stage binary counter, 343
Four-stage synchronous counter, 347
Fractured solder connection, 424–425, 433
Free-running multivibrator, 299
Frequency, 105, 129
 cut-off, 159
 fundamental, 131, 303
 ripple, 251
Frequency counter, 139–140, 422, 423
Frequency division, 343, 347
Frequency-domain analysis, 303–305
Friction, 18
Full adder, 364
Full scale value, 70
Full subtractor, 365–366
Full-wave rectifier, 251–252, 253
Full-wave voltage doubler, 261–262, 262
Function generator, 423, 424
Functional diagram, 428, 429
Fundamental frequency, 131, 303
Fuse, 264, 264

G

G, 32
GaAs, 244
GaAsP, 244
Gallium arsenide (GaAs), 244
Gallium arsenide phosphide (GaAsP), 244
Gate, 214
Gate-to-source cut-of voltage, 215
Gate-to-source voltage, 215

Generator, 19
 AC, 104–105, 126–127
 DC, 105–106
 defined, 18
 Van de Graaf, 18, 18
Gerber format, 401
Germanium, 184, 185
giga-, 14
Glossary, 455–465
Graticule, 137
Greek alphabet, 505
Ground, 28–29
Ground plane, 388
Ground symbols, 395
Grown junction method, 195–196

H

H, 111
Half adder, 364
Half subtractor, 365, 366
Half-wave rectifier, 250–251
Half-wave voltage doubler, 261, 261
Hand-draw, 402
Harmonics, 131, 303
Hartley oscillator, 294–295
Heat sink, 282, 282, 418
Henry (H), 111
Henry, Joseph, 111
Hertz (Hz), 127
High, 323
High-pass filter, 151, 291, 291
Hole, 12, 186
Hot molded potentiometer, 33
Hybrid integrated circuits, 235
Hz, 127

I

I, 7, 11
I/O, 372
I/O instructions, 378
IC, 232–238
IC regulator, 260, 260
IC Wien-bridge oscillator, 298, 298
ICE, 149
Idling, 426
IF amplifier, 286, 287
Illuminated magnifier, 420
Impedance, 157, 164, 514

Impedance coupling, 274, 274
Impedance ratio, 174
In phase, 162
Induced voltage, 103
Inductance
 AC circuits, 155–158
 DC circuits, 110–115
 formula, 514
 mutual, 173
Inductive AC circuits, 155–156
Inductive reactance, 156
Inductor, 111–114
Infrared light, 240
Input/output (I/O), 372
Input/output instructions, 378
Instruction register, 372
Insulator, 6–7, 8
Integrated circuit (IC), 232–238
Integrated circuit (IC) regulator, 260, 260
Integrated circuit packaging, 236
Integrator, 306–307
Integrator circuit, 306
Intermediate frequency (IF) amplifier, 286, 287
Interrupt, 375
Interstage transformer, 280
Intrinsic material, 184
Inverter, 323
Inverting amplifier, 290
Inverting input, 287
Ionization, 7
Iron-vane meter movement, 133–135
Isolated I/O, 378
Isolated power supply, 421, 421
Isolation transformer, 176, 446, 447

J

JFET, 213–216
JK flip-flop, 341, 341, 342
Jumper, 397, 398
Junction diode, 192. *See also* PN junction diode
Junction field effect transistor (JFET), 213–216
Junction transistor, 204

K

Karnaugh, Maurice, 333
Karnaugh diagram, 333–336
Kilby, Jack, 233
kilo-, 14

Kirchhoff, G. R., 57
Kirchhoff's current law, 57
Kirchhoff's voltage law, 58

L

L, 110–111
L/R time constant, 113, 114
Lagging output phase-shift network, 153
Laminated iron-core inductor, 112, 113
Large-scale integration (LSI), 236
Latch, 341
Law of electrostatic charges, 11
LC oscillator, 294–295
LCC package, 236
Lead-acid battery, 22–23, 25
Lead-lag network, 297
Leading edge, 305
Leading output phase-shift network, 153
Leadless chip carrier (LCC) package, 236
Leclanche cell, 22
LED, 244–245
Leg warmers, 428, 428
Lenz's law, 111
Light, 240
Light-emitting diode (LED), 244–245
Light-sensitive devices, 240–243
Lillienfield, Julius, 213
Limiter circuit, 307
Linear electronic circuits, 247–312
 amplification, 267–292. *See also* Amplification
 oscillator, 293–301. *See also* Oscillator
 power supplies, 249–266. *See also* Power supplies
 waveshaping circuits, 302–312. *See also*
 Waveshaping circuits
Lithium cell, 22, 24
Livewire, 395, 396
Livingston, Edward M., 2
Load, 50
Loading down, 280
Logic circuits
 combinational, 356–370
 sequential, 338–355
Logic elements, 321
Logic gates, 321–327
Logic instructions, 377
Logic probe, 423, 424
Logic pulser, 423
Logic symbols, 513
Loudspeaker, 106

Low, 323
Low-pass filter, 151, 291, 291
Low-wattage soldering iron, 426
LSI, 236

M

Magnet, 97
Magnetic field, 98
Magnetic induction, 101–103
Magnetic recording, 107
Magnetic shield, 102
Magnetism, 96–109

- applications, 104–108
- Faraday's law, 103
- magnetic induction, 101–103
- permeability, 99
- polarity, 101
- strength of magnetic field, 100–101

Main terminal 1 (MT1), 226
Main terminal 2 (MT2), 226
Mainframe, 371
Maintenance and repairs, 444–454. *See also*
 Troubleshooting
Majority carrier, 187
Manual desoldering tool, 419
Masking, 377
Material safety data sheet (MSDS), 406–412
Matter, 4
Maximum zener current, 200
MCS 51, 378
MCS 251, 378
Measurements. *See* AC measurements; DC
 measurements
Medium-scale integration (MSI), 236
mega-, 14
Memory, 351–354, 374
Memory address register, 374–375
Memory circuits, 321
Memory register, 351, 374
Metal oxide varistor (MOV), 264
Meter

- AC, 133–136. *See also* AC measurements
- DC. *See* DC measurements

Meter scales, 70–72
Metric prefixes, 506
Mho, 32
Mica, 7
micro-, 14
Micro-Cap 7, 396

Microampere, 15
Microcomputer basics, 371–381
Microphone, 20
Microprocessing unit (MPU), 372
Microprocessor architecture, 375–378
milli-, 14
Milliampere, 14–15
Mini-DIP, 237
Minority carrier, 187
Miscellaneous instructions, 378
Mixture, 4
Mobile charges, 191
Modulus, 342
Molded carbon composition resistor, 34, 34
Molecule, 4
Monolithic integrated circuits, 234–235
Monostable multivibrator, 309, 310
MOS memory, 352
MOSFET

- depletion, 216–218
- enhancement, 218–220
- safety precautions, 220
- testing, 220–221

MOV, 264
Moving coil meter, 133
MPU, 372
MSDS, 406–412
MSI, 236
Mu-metal, 102
Multilayer board, 389
Multimeter, 64–65
Multiple-stage amplifier, 278
Multiple-stage counter, 343
Multiplexer, 360–363
MultiSIM, 140, 395
Multivibrator, 299, 299
Mutual inductance, 173

N

N-channel depletion MOSFET, 216–217
N-channel enhancement MOSFET, 219
N-channel JFET, 214
N-type material, 188
nano-, 14
Needle nose, 417
Negative alternation, 127
Negative feedback, 270
Negative ion, 7
Negative temperature coefficient, 185

Negative zener voltage-temperature coefficient, 200
Neutron, 5
Nibble, 351
Nickel-cadmium (Ni-Cad) cell, 23, 25
Noninverting amplifier, 290
Noninverting input, 288
Nonsinusoidal oscillator, 298–300
Nonsinusoidal waves, 130–131
NOR gate, 324
Normal fuse, 264
NOT gate, 323–324
Noyce, Robert, 233
NPN transistor, 205, 205
Nucleus, 5, 184
Nut drivers, 418

O

Odd harmonics, 131
Ohm, 8, 32
Ohm, George Simon, 8, 51
Ohm's law, 51–56
Ohmmeter, 63, 68–69, 444, 445
1-of-8 decoder, 359, 359
1-of-10 decoder, 358
1-of-16 decoder, 359, 359
One-ounce copper plating, 386
One-shot multivibrator, 309
Op-amp, 287–291
Open circuit, 51, 68, 117, 449, 450
Open-loop mode, 288
Optical coupler, 245, 245
Optoelectric devices, 239–246
 LED, 244–245
 light-sensitive devices, 240–243
 photo cell, 240–241
 photodiode, 241–242
 phototransistor, 242
 solar cell, 241
OR gate, 322
Oscillator, 293–301
 block diagram, 294
 crystal, 295–297
 defined, 294
 LC, 294–295
 nonsinusoidal, 298–300
 RC, 297–298
 sinusoidal, 294–298
 tank circuit, 293
Oscilloscope, 136–139, 423, 446, 446
Oscilloscope probe, 423
Out of phase, 162
Over-voltage protection circuit, 263–264
Overshoot, 305, 305

P

P-channel depletion MOSFET, 217–218
P-channel enhancement MOSFET, 218–219
P-channel JFET, 214
P-type material, 188–189
Pad, 397–398
PAL, 368
Paper and plastic capacitor, 118, 119
Paper doll, 396, 397
Parallel circuit, 40, 41, 50
 AC circuit, 144
 DC circuit, 82–84
Parallel configuration, 26
Parallel counter, 343
Parallel-to-serial data conversion, 350, 361, 362
Passive filter, 291
PCB, 385–443. *See also* Printed circuit board (PCB)
PCB holders, 420
PCI16C57, 378
Peak inverse voltage (PIV), 194, 255
Peak reverse voltage, 199
Peak-to-peak value, 128, 129
Peak value, 128, 128
Pencil soldering iron, 425, 425, 426
Pentavalent, 187
Period, 129, 304, 305
Periodic table of elements, 504
Periodic waveform, 303, 304
Permanent magnet, 97
Permeability, 99
Personal safety, 435–437
PGA, 236
Phase-shift network, 153
Phase-shift oscillator, 297
Phase splitter, 280, 281
Phonograph pickup, 106
Photo cell, 240–241
Photoconductive cell, 240–241
Photodiode, 241–242
Phototransistor, 242
Photovoltaic cell (solar cell), 18–19, 241
pico-, 14
Pictorial diagram, 428, 429
Pierce oscillator, 296, 297

- Piezoelectric crystal, 20
 - Piezoelectric effect, 20
 - Pin grid array (PGA), 236
 - PIN photodiode, 242, 242
 - Pinch off, 215
 - Pinch-off voltage, 215
 - PIV, 194, 255
 - PLA, 368–369
 - Place value, 315
 - Plastic and orangewood spudgers, 416
 - Plastic quad flat package (PQFP), 236
 - Plate, 116
 - PLD, 368–369
 - PN junction diode, 191–198
 - PN junction photodiode, 241
 - PNP transistor, 205, 205
 - Polarity, 101
 - Positive alternation, 127
 - Positive edge-triggered, 340
 - Positive feedback, 294
 - Positive ion, 7
 - Positive zener voltage-temperature coefficient, 200
 - Potential, 7
 - Potentiometer, 33, 36
 - Power
 - apparent, 167
 - DC circuits, 75–79
 - defined, 75
 - formula, 514
 - resistive AC circuits, 146–147
 - resonance circuits, 167–168
 - Power dissipation ratings, 200
 - Power factor, 168
 - Power supplies, 249–266
 - circuit breaker, 265
 - circuit protection devices, 263–265
 - filter circuits, 253–255
 - fuse, 264
 - overprotection circuit, 263–264
 - rectifier circuits, 250–253
 - transformer, 217
 - voltage multiplier, 261–263
 - voltage regulator, 256–260
 - PQFP, 236
 - Primary cell, 21–22
 - Primary winding, 171
 - Printed circuit board (PCB), 385–443
 - breadboarding, 395–396
 - etched PCB, 403–405
 - fundamentals, 385–389
 - layout, 396–402
 - MSDS, 406–412
 - schematic diagram, 389–395
 - soldering, 427–432
 - test equipment, 421–424
 - transferring designs, 402–403
 - Printed circuit board holders, 420
 - Program, 374
 - Program-control instructions, 377
 - Program counter, 372, 376
 - Programmable array logic (PAL), 368
 - Programmable logic array (PLA), 368–369
 - Programmable logic device (PLD), 368–369
 - Programmable read-only memory (PROM), 353–354, 368
 - Project/equipment data recording chart, 451
 - PROM, 353–354, 368
 - Protective coatings, 434–435
 - Proton, 5, 184
 - Pspice, 395
 - Pulse waveform, 131
 - Pulse width, 130, 304, 305
 - Pure semiconductor, 186–187
 - Push-pull amplifier, 280, 281
 - Push-pull amplifier configuration, 273
 - Pyrometer, 20
- ## Q
- Quartz, 296
 - Quasi-complementary power amplifier, 281, 281–282
- ## R
- Radial capacitor lead, 118
 - Radio frequencies, 285–287
 - Radio frequency (RF) amplifier, 285–286
 - Random-access memory (RAM), 353
 - RC circuit, 120, 120
 - RC coupling, 273–274, 274
 - RC coupling network, 152–153, 153
 - RC decoupling network, 152, 152
 - RC high-pass filter, 151–152, 152
 - RC low-pass filter, 151, 151
 - RC network, 151
 - RC oscillator, 297–298
 - RC time constant, 120

- Reactance, 168–169
 - capacitive, 149–150
 - formula, 514
 - inductive, 156
 - parallel circuit, 165–166
 - series circuit, 161–164
 - Read-only memory (ROM), 353
 - Rectification, 133
 - Rectifier, 133, 250–253
 - Rectifier circuits, 250–253
 - Regenerative feedback, 223, 297
 - Relaxation oscillator, 298
 - Relay, 106, 106
 - Repairs, 444–454. *See also* Troubleshooting
 - Repelling, 10
 - Residential circuit panel box, 29
 - Residual magnetism, 102
 - Resist, 387
 - Resistance, 8, 31–32, 514
 - Resistive AC circuits, 142–147, 162
 - Resistive-capacitive (RC) coupling, 273–274, 274
 - Resistor, 32–47
 - defined, 32
 - identification, 37–39
 - parallel circuit, 41
 - series circuit, 40
 - series-parallel circuit, 43–47
 - types, 34–36
 - Resistor color codes, 507
 - Resistor identification, 37–39
 - Resonance, 168–169, 514
 - Resonant circuit, 169
 - Retentivity, 102
 - Reverse bias, 194
 - Reverse current, 194
 - RF amplifier, 285–286
 - Rheostat, 36, 36
 - Rickman, Raymond L., 314
 - Right-hand motor rule, 107
 - Ringing, 305, 305
 - Ripple counter, 343
 - Ripple frequency, 251
 - Rise time, 304–305, 305
 - RL circuit, 113, 113, 157
 - RL high-pass filter, 158, 159
 - RL low-pass filter, 158, 158–159
 - rms value, 129
 - Rochelle salt, 296
 - ROM, 353
 - ROM family chart, 353
 - Root-mean-square (rms) process, 129
 - Rosin connection, 433
 - Rotate and shift instructions, 377
 - Round nose pliers, 417
 - RS flip-flop, 339
- ## S
- S, 32
 - Safety, 435–437
 - Sampling circuit, 258
 - Sawtooth waveform, 131, 131, 303
 - Scaling, 88
 - Schematic diagram, 447–448, 448
 - Schematic drawing lines, 395, 395
 - Schematic symbols, 393, 394, 511–513
 - AC, 19
 - ammeter, 63
 - battery, 19
 - capacitor, 117, 393
 - cell, 19
 - crystal, 296
 - depletion MOSFET, 217, 218
 - DIAC, 228
 - enhancement MOSFET, 219
 - fixed capacitor, 117
 - inductor, 111
 - iron-core inductor, 112
 - JFET, 215
 - LED, 245
 - op-amp, 288, 289
 - photo cell, 241
 - photodiode, 243
 - phototransistor, 243
 - piezoelectric crystal, 20
 - potentiometer, 393
 - resistor, 393
 - SCR, 225
 - semiconductors, 512
 - solar cell, 20, 241
 - thermocouple, 20
 - transformer, 172
 - TRIAC, 227
 - variable capacitor, 117
 - variable inductor, 111
 - zener diode, 200
 - Schmitt trigger, 310, 310
 - Scientific notation, 13–15

- SCR, 223–226
- Screwdrivers, 418
- Second harmonic, 303
- Secondary cell, 22–23, 25
- Secondary winding, 171
- Self-adjusting series regulator, 257
- Self-test answers, 467–501
- Semiconductor, 7, 184
- Semiconductor devices, 181–246
 - bipolar transistor, 204–212
 - DIAC, 228
 - FET, 213–222
 - fundamental principles, 183–190
 - IC, 232–238
 - JFET, 213–216
 - light-emitting devices (LED), 244–245
 - light-sensitive devices, 240–243
 - MOSFET, 216–221
 - N-type material, 188
 - optoelectric devices, 239–246
 - P-type material, 188–189
 - PN junction diode, 191–198
 - schematic symbols, 512
 - SCR, 223–226
 - thyristors, 223–231
 - TRIAC, 226–227
 - zener diode, 199–203
- Semiconductor fundamentals, 183–190
- Semiconductor schematic symbols, 512. *See also*
 - Schematic symbols
- Sequential logic circuits, 338–355
- Serial-to-parallel data conversion, 350
- Series-aiding configuration, 25
- Series circuit, 40, 40, 50
 - AC circuit, 143–144
 - DC circuit, 80–82
- Series diode clipping circuit, 307
- Series-fed Hartley oscillator, 294
- Series-opposing configuration, 26
- Series-parallel circuit, 40, 43–47, 50, 84–88
- Series-parallel configuration, 26, 27
- Series peaking, 283, 283
- Series regulator, 257, 257
- Series RL network, 158–159
- Series-shunt peaking, 284
- Sharpie, 402
- Shell, 5
- Shield inductor, 112, 112
- Shift register, 345, 349–351
- Short circuit, 68, 449, 450
- Shunt clipping circuit, 308, 308
- Shunt-fed Hartley oscillator, 295, 296
- Shunt peaking, 283, 283
- Shunt regulator, 256, 257
- Siemens (S), 32
- Signal generator, 422, 424
- Silicon, 184–185
- Silicon-controlled rectifier (SCR), 223–226
- Sine wave, 127–128, 303
- Single-sided PCB, 389
- Sinusoidal oscillator, 294–298
- Sinusoidal waveform, 127–128
- Sixteen-input multiplexer, 362
- 60/40 solder, 425
- 63/37 solder, 425
- 68HC11, 378
- Slip rings, 127
- Slow-blow fuse, 264
- Small-scale computer, 371
- Small-scale integration (SSI), 236
- SMT, 387, 401
- SOC, 236
- Solar cell, 18–19, 241
- Solder connection, 433, 434
- Solder gun, 425, 426
- Solder mask, 388
- Solder pump, 431, 432
- Solder side, 387
- Solder wick, 419
- Soldering, 424–433
 - analyzing soldered connections, 433
 - defects, 433
 - defined, 424
 - PCB, 427–433
 - tools, 424–426
- Soldering iron, 419, 425
- Soldering iron tips, 426, 427
- Solderless breadboard, 395, 396
- Solenoid, 106, 106
- Source, 214
- Spectrum analyzer, 304, 304
- Sputtering process, 235
- Square wave, 130, 130, 131, 303
- SRAM, 353
- SSI, 236
- Stack, 377
- Stack instructions, 377
- Stack pointer, 376, 377

Stage, 342
Static electricity, 437, 438, 438–441
Static RAM (SRAM), 353
Step-down transformer, 174
Step-up transformer, 173
Storage register, 351, 374
Subtractor, 291, 365–366
Summing amplifier, 290, 290–291
Surface-mount resistor, 35–36
Surface mount technology (SMT), 387, 401
Surgical scissors, 416
Symbols. *See* Schematic symbols
Synchronous, 343
Synchronous BCD decade counter, 348
Synchronous counter, 343, 344, 345, 346, 347
Synchronous operation, 340
System-on-chip (SOC), 236

T

Tank circuit, 293
Television frequencies, 285–287
Television receiver, 283, 284
Temperature-compensated zener diode, 200
Temperature-controlled soldering station, 426
Temporary magnet, 97
Tesla, Nikola, 126
Test equipment, 421–424
Thermal instability, 270
Thermocouple, 19–20
Thick-film capacitors, 235
Thick-film integrated circuits, 235
Thin-film capacitors, 235
Thin-film integrated circuits, 235
Thin small outline package (TSOP), 236
Third harmonic, 303
Three-stage binary counter, 343, 344, 346
Three-state buffer, 327, 327, 328, 328
Three-terminal IC regulator, 260
Thyristor, 223–231
 DIAC, 228
 SCR, 223–226
 testing, 229–230
 TRIAC, 226–227
Time base, 138
Time constant
 L/R, 113, 114
 RC, 120
Time-domain analysis, 302, 303

Tin oxide resistor, 35
Tin-plating, 405
Tinning, 426
Tolerance, 33
Toolbox, 416–421
 soldering, 424–426
 test equipment, 421–424
 troubleshooting, 444–448
Top (component side), 387
Toroid-core inductor, 112, 112
Tourmaline, 296
Trace, 385
Trace layout do's and don'ts, 400, 401
Trailing edge, 305
Transformer, 171–178, 217
Transformer coupling, 274, 274
Transient, 220
Transistor packages, 206
Transistor series regulator, 257
Transistor substitution, 209–210
Transistor testing, 208–209
Transistor-to-transistor logic (TTL) memory, 352
Transparent latch, 341
TRIAC, 226–227
Triangular waveform, 130, 130–131
Trim potentiometer, 33
Trimming potentiometer, 33
Trivalent, 187
Troubleshooting, 444–454
 defects, 449–450
 documentation, 453
 steps in process, 448–449
 tips, 452
 tools, 444–448
Truth table, 321
TSOP, 236
TTL memory, 352
Tuned amplifier, 285
Turns ratio, 173
TV frequencies, 285–287
Tweezers, 417
Two-stage binary counter, 343
Two-stage DC amplifier, 278, 278
Two-stage synchronous counter, 345

U

Ultra-large scale integration (ULSI), 236
Ultraviolet light, 240

Undershoot, 305, 305
Unity-gain amplifier, 290
Untuned amplifier, 285
Up-down counter, 345, 348

V

V, 7
VA, 172
Valence, 5, 184
Valence band, 6
Valence shell, 5
Van de Graaf generator, 18, 18
Vance, Vercell, 384
Variable autotransformer, 176–177, 177
Variable capacitor, 117, 119
Variable inductor, 111, 111
Variable resistor, 33, 36, 36
Vector, 163–166
Veitch diagram, 330–333
Very large-scale integration (VLSI), 236
Via, 389, 390
Video amplifier, 282–284
Virtual breadboarding, 396
Virtual test equipment, 395
VLSI, 236
Voids, 433
Volt (V), 7
Volt-ampere (VA), 172
Volt-ohm-milliammeter (VOM), 64, 421
Volta, Alessandro, 7
Voltage, 7, 17
Voltage divider, 88–93
Voltage-divider feedback circuit, 271, 271–272
Voltage doubler, 261
Voltage drop, 27, 27–28
Voltage multiplier, 261–263
Voltage regulator, 256–260
Voltage rise, 27, 27
Voltage source, 17–21, 49
Voltage tripler, 262, 262–263
Voltmeter, 63, 67–68, 444, 445
VOM, 64, 421

W

Walls, Ronald G., 182
Water-scale integration (WSI), 236
Watt, 76
Waveshaping circuit, 302–312
 bistable multivibrator, 310
 clamping circuit, 309
 clipping circuit, 307–308
 differentiator, 306
 flip flop, 310, 310
 frequency-domain analysis, 303–305
 integrator, 306–307
 monostable multivibrator, 309, 310
 Schmitt trigger, 310, 310
 special-purpose circuits, 309–310
 time-domain analysis, 302, 303
Wheatstone, Sir Charles, 93
Wheatstone bridge, 93–94
Wicking, 433
Wien-bridge oscillator, 297–298, 298
Wire strippers, 416
Wirewound resistor, 34, 34–35
Wiring diagram, 428, 429, 447, 448
WSI, 236

X

X-acto knife, 416
XNOR gate, 326
XOR gate, 325–326

Y

Yield, 235

Z

Zener diode, 199–203
Zener diode regulator circuit, 201, 256
Zener region, 199
Zener test current, 199
Zener voltage rating, 201