



TECHNOLOGY IN ACTION™

Building Your Own Electronics Lab

A Guide to Setting
Up Your Own
Gadget Workshop



Dale Wheat

For your convenience Apress has placed some of the front matter material after the index. Please use the Bookmarks and Contents at a Glance links to access them.



Apress®

Contents at a Glance

■ About the Author	xi
■ About the Technical Reviewer	xii
■ Acknowledgments	xiii
■ Introduction	xiv
■ Chapter 1: Planning Your Electronics Workshop	1
■ Chapter 2: Building Your Tool Chest	19
■ Chapter 3: Components	57
■ Chapter 4: A Portable Mini-Lab	87
■ Chapter 5: The Cozy Corner Lab	105
■ Chapter 6: The Small Group Lab and Classroom	135
■ Appendix A: Getting Started with Tool Building	145
■ Index	161

Introduction

We're surrounded by electronics these days. Did you ever wonder how it all worked? Do you know just enough about electricity to be dangerous? Would you like to learn more? Then this book is for you.

There are many excellent textbooks on how electricity works. This is not one of them. This book helps you get started learning about electricity and electronics by showing you how to set up your own electronics laboratory. You might have guessed that from the title.

Along the way, several simple exercises are presented to show you some basic concepts about how electricity works in the real world—not just in a lecture hall. By the time you get done reading this short book, you'll have a good idea of where to begin and what kinds of tools and components you might need, and you'll have some excellent advice about how to keep it all organized.

Once you've got your own space set up to perform your electronic experiments, the sky is the limit.

Here's what you have to look forward to in this book, one chapter at a time.

Chapter 1: Planning Your Electronics Workshop

Your very own electronics laboratory is a great place to build, repair, invent, and learn more about electronics. We seem to be surrounded by electronics more and more every day. We can easily become dependent upon them, without even understanding how they work. Having your own electronics lab can help you gain some control over your electronic minions. Here you can learn about their inner mysteries, including how to repair them when possible or, better yet, improve them with your own custom modifications. You can also turn your own ideas into reality by building electronic circuits from scratch.

What will you need to plan your lab? What if you already have a basic understanding of electronics and the beginnings of a workshop at your disposal? This chapter helps get you going in the right direction.

Chapter 2: Building Your Tool Chest

You're going to need some tools in your lab, as well as the skills to use them effectively. This chapter will get you started.

If you're starting from scratch, don't worry. There's not a whole lot you absolutely *must* have to get started. Some basic hand tools and a place to keep them organized is all you will need. You don't even have to spend a lot of money at first. As you progress in your hobby, you will most likely want to add to your tool chest and upgrade some of those tools. Electronics can be the perfect hobby because it can take up (1) all your spare time and (2) all your discretionary income. What more could you ask for?

Chapter 3: Components

You're going to need some components to play with, as well as the knowledge to use them effectively. This chapter will introduce you to some of the bits and pieces that make up modern electric and electronic circuits. You'll also learn a little bit about how to identify components from their appearance and markings, when available.

Once you've got an idea about what these parts do in a circuit, you'll learn a little more about how to measure their electrical properties and put them to use. You'll also be shown what *not* to do, in some select examples.

Chapter 4: A Portable Mini-Lab

Having a portable (or at least (*transportable*) electronics lab comes in handy in several circumstances. Maybe you don't have a place (yet) for a permanent home for all that equipment. Maybe you need to bounce at a moment's notice, heading off on electronic adventures at the drop of a hat. Or maybe you like to keep everything where you can find it in a hurry, without having to rummage through shelves and boxes, looking for just the right tool or component.

Whatever your motivation for wanting a portable lab at your disposal, this chapter should help you get started.

Chapter 5: The Cozy Corner Lab

You don't need an entire garage or extra office for a functional laboratory for your electronic endeavors. It's certainly nice if these areas are available to you, but you might be surprised at how much you can do in just a small space, if you set it up properly and maintain it with determination.

Chapter 6: The Small Group Lab and Classroom

The first part of this book deals with how to get along with electrons and make them do your bidding. In this chapter, you'll explore a completely different topic: other people, and how to get along with them.

You might not ever figure out how to get *them* to do your bidding, but at least you can keep them from stealing your tools. Maybe.

Appendix A: Getting Started with Tool Building

Once you've become comfortable in your lab and had time to play with a few circuits, you might start to notice that some of the "tools" you've been using are just simple electronic circuits themselves. Good examples are power supplies and meters. These are great tool-building projects because you can see useful results early.

This appendix takes a look at building a couple of simple electronic tools that might be of use in your lab. Hopefully you will develop a better understanding of how these tools work. Ideally, you will progress from the basic question of "Does it work?" to the more involved questions of "How well does it work and what can I do to improve it?"

Planning Your Electronics Workshop

Are you interested in electronics? Would you like to set up your own “electro lab” to conduct amazing experiments, build crazy gizmos, and repair or modify your existing electronics? Then this book is for you!

Your very own electronics laboratory is a great place to build, repair, invent, and learn more about electronics. We seem to be surrounded by electronics more and more every day. We can easily become dependent upon them, without even understanding how they work. Having your own electronics lab can help you gain some control over your electronic minions. Here you can learn about their inner mysteries, including how to repair them when possible or, better yet, improve them with your own custom modifications. You can also turn your own ideas into reality by building electronic circuits from scratch.

What will you need to plan your lab? What if you already have a basic understanding of electronics and the beginnings of a workshop at your disposal? This chapter helps get you going in the right direction.

What to Expect

This book can't teach you everything about electronics, and it doesn't try. That would take several lifetimes. What it can do is introduce you to the tools and the skills you will need to set up your own electronics lab. This will include a very basic introduction to electricity, a little bit of theory, some safety tips, and a whole lot of example projects. It's a great starting place. Where it will lead you is mostly determined by you and what you're wanting to do with electronics.

If you're already familiar with electricity and electronic concepts, there is still plenty of fun and interesting stuff waiting for you to explore. The field of electronics itself is constantly expanding. From the time this book was written to the time that you've finished reading this sentence, many advances will have occurred in both our understanding of electronics as well as the development of new applications and electronic devices. This is one of the many things that makes the study of electronics so interesting and exciting.

Every lab is different. Your lab will reflect not only your immediate electronics goals but also your personality. Feel free to pick and choose from all the ideas presented in this book and add in some of your own. The repair shop and the design studio are necessarily going to be arranged differently. There really is no right or wrong way to go.

Even the best laid plans, so the saying goes, end up somewhere unexpected. When planning your electronics lab for the first time, or for the tenth time, keep in mind that your interests, resources, and reasons for wanting to work on electronics are going to change over time. Please feel free to reinvent yourself and your lab as conditions permit. You might also be forced to reconsider your priorities when

other factors in your life exert themselves. That being said, stay tuned for “A Cautionary Tale” at the end of this chapter.

Some configurations are more appropriate for certain endeavors, and nothing replaces the right tool for the job. This book should at least give you an idea of what is involved and get you pointed down the right road.

It Starts with a Plan

Most of the decisions you’ll make when planning your laboratory will depend on what *you’re* interested in doing there. Having a good plan at the beginning is like having a clear map when taking a long journey. It helps you from getting lost and also is handy for figuring out when you’ve arrived.

■ **Note** If you fail to plan, you plan to fail.

Remember, at this point in the game, you don’t have to make any final decisions about what you want to be able to do in your lab. This book is all about illustrating possibilities and giving you the information and advice necessary to branch out into the areas that hold the most interest for *you*.

A Broad Outline

Here’s what you need to get started: a little time, a small amount of space, some basic tools, and a few components. Those are the boring parts. The fun stuff includes your ideas, goals, and inspiration. Combine all that with some fundamental information about how electricity and electronics work, and you’re in business.

A Little Time

Like any good hobby, setting up your electronics lab and conducting experiments there is going to take up some of your time. For some, this is the *main reason* for getting started in electronics and building a lab: a place to escape, unwind, and tinker with ideas, prototypes, and complex systems. Maybe it’s your job. Maybe it’s your passion. Perhaps it’s a bit of both.

You’re going to need time to plan and build your lab. This book will spell out several specific arrangements for various-sized labs, but they are just examples and not hard-and-fast rules. More time will be required for obtaining the proper tools and materials that you will use there. Time will be spent not only *doing* things in your lab, but also in just *thinking* about doing things in your lab. For example, you might build a clever little gizmo that ought to do a simple task, only to find out that it refuses to work. You might need to spend a little bit of time thinking of ways of testing it to find out where the problem lies. This is sometimes called *troubleshooting* or *debugging*.

This is the basis of the scientific method. To help understand how something works, you first form a theory that would explain its behavior. Next you prepare one or more experiments that will demonstrate the accuracy of your theory. The experiments are conducted and their results are analyzed. If the results are in agreement with your theory’s predictions, then your theory is more than likely correct. If not, you may need to modify or extend your theory to accommodate the behavior observed. All of these things take time, which helps explain why we don’t have jet packs or time machines yet.

A Little Space

You don't have to start out with a cavernous underground bunker for your electronics lab. If you already have one, that's great. You might have an extra classroom available, some unused warehouse space, or an empty bench in a garage.

Then again, you might only have a corner of the dining-room table, and then only between mealtimes. That's plenty of room when you're just getting started! Once you learn more about electronics, and especially when you learn more about what it is that *you* want to do with electronics, then you can start looking for a more permanent home for your toys, tools, and spare parts.

The main points that will be stressed throughout this book when planning and working in your space are safety, good lighting, and organization, in that order.

- Your lab needs to be relatively safe for you, and *very* safe for your visitors and neighbors. The “Go Away!” sign on the door does not guarantee that you will be free from curious visitors, pesky and otherwise. People are naturally attracted to the creative and mysterious activities going on in your lab.
- Be prepared to buy, build, or borrow more lighting, because you're going to need it. Proper lighting improves the quality of your doodlings and tinkering enormously. You might think you already have enough light, and unless you were a photographer in a previous life, you don't. (Photographers understand that you can never have too much light.)
- An organized lab is a productive lab. Don't waste time looking for parts or tools when it would have only taken mere moments to put them in their proper places in the first place. A place for everything, and everything in its place. You get to decide where all these tools and bits get to live, so spend some time and do it wisely.

These three tenets will be repeated throughout the book, so you might as well get used to hearing about them.

Basic Tools

You really don't need a lot of tools to get started. There is a tendency to want to be a bit overprepared before tackling any new project, but it really isn't necessary when it comes to planning and building a new electronics lab. This is also true when sorting out a lab that's gone badly out of control.

You're going to be working with wire quite often. Claude Debussy has been quoted as saying that music is the space between the notes. It's the connections between the various electronic components that make the magic happen in an electronic circuit, in the same way that it's the relationships between people that make their lives so interesting.

The connections between all the various imaginable electronic components almost always start out as bits of wire. These connections can then be optimized into copper traces etched on a printed circuit board or even as metallization links in an integrated circuit. You're going to be working with a lot of wires in this hobby, and that usually boils down to two basic hand tools: *wire cutters* and *wire strippers*.

A wire cutter does what it says and says what it does: it cuts wire. A wire stripper is a more specialized tool that helps remove the outer layer of insulation from a wire. Ever more specialized versions of both tools abound. Some tools aim to perform both tasks at once, while never perfecting the art of either.

Resist the temptation to use your teeth for cutting and stripping wire. If you're caught in a situation without proper tools, use your fingernails. They grow back faster than teeth.

■ **Tip** Use the right tool for the job. Knowing which tool is the right tool is half the battle.

If you're performing detailed work on smaller circuits, you might benefit from having some small needle-nosed pliers, a small vise, clip, or helping-hands jig, and possibly a magnifying glass.

A popular and handy skill in the electronic arena is *soldering*. Soldering is the process of making electrical and mechanical connections. This is done by heating the items to be joined together and adding solder. The solder melts and fills in all the gaps between the items being joined. Once cooled, the solder forms a solid, conductive link.

■ **Note** Soldering is similar to welding, with the exception that welding actually melts the parts being joined.

A suitably sized soldering iron and the right kind of solder are indispensable for many projects, including repair, prototyping, and production. Picking up the skill to make quality connections is obtained in the same way as all worthwhile skills: with lots of practice.

Besides these basic fabrication tools, you will also want some *test and measurement equipment*. These are devices used to measure various aspects of electrical circuit behavior. These range from the very simple, such as voltage meters, current meters, and continuity testers, to the very exotic (and sometimes expensive), which include oscilloscopes and various logic, network, and signal analyzers. See the Appendix for information about building your own simple test equipment for your lab.

This is just a quick summary of the kinds of tools you might want in your electronics lab. Chapter 2 goes into much more detail about the tools you will probably need or want in your lab, as well as the skills needed to operate them safely and effectively.

Fundamental Components

As mentioned in the previous section, you're more than likely going to be wiring up various contraptions and rewiring others. This is probably going to involve a lot of wire.

For small voltages and currents, small-gauge insulated copper wire is often used. It's easy to handle, cut, and splice. This can be done with mechanical connectors such as wire-nuts or screw terminals, as well as with soldering.

Back in the day when computers were all connected using fat cables, lots of tiny wires were bundled up into cables and snaked all over a typical desktop computer installation. With the increasing popularity of wireless devices, those fat, juicy cables are lying around, discarded, unwanted, and just waiting to be harvested for their valuable conductors. You can also buy various kinds of wire in all colors and sizes from most hardware stores and from online suppliers.

Now consider the types of projects you'll be working on:

- If you're most interested in building your own lighting, you're going to want some lightbulbs, sockets, and LEDs, or whatever lighting technology appeals most to you. Don't forget that you're also going to need switches, knobs, dimmers, housings, plugs, and *more wire*.

- If you like to work with things that move, you're going to need motors, relays, solenoids, servos, and fans. You'll probably be needing some gears, pulleys, chains, belts, shafts, and couplings, along with connectors, switches, controllers, position sensors, and *more wire*.
- If you're into making lots and lots of sound, you'll be needing speakers, headphones, microphones, pickups, transducers, transformers, amplifiers, connectors, jacks, plugs, and, you guessed it, *more wire*.
- Are computers and digital devices more to your liking? Be thinking about getting yourself a wide variety of chips, microcontrollers, software, cables, sockets, connectors, and still *more wire*.

Now you've got an idea of some of the different components you might want to have on hand, depending on what kind of inspiration happens to strike. You're going to need a place to keep all these different parts sorted. This will play a big part in the overall planning phase of your lab. Maybe your old fishing tackle box has enough room for your basic hand tools and enough secret compartments to hold an interesting variety of components. On the other end of the spectrum, maybe you need to start thinking about some industrial-grade shelving units or pallet racks. Now is the time to think about all these factors and start making the right kind of plans to help make your lab a successful one.

Again, this is just a quick summary of some of the types of components you might want to work on in your lab. Chapter 3 is going to take you much farther into understanding many of the more common electrical and electronic components that you are likely to encounter in your lab.

Ideas

Admit it: you've already got some ideas for cool projects that you'd like to be working on in your own electronics lab. That's great! You're well on your way to making those dreams a reality.

The best possible thing you could do with your ideas is to write them down somewhere. It can be as simple as a sketch on a piece of scrap paper or as formal as a complete set of project documentation. The important thing is that you actually get the idea across using either words or pictures in a form that you will be able to revisit in the future. This will be of immense benefit to you, as well as anyone else that might be interested in your ideas.

It's also a great idea to keep a log as you work on your projects. That's the perfect place to jot down those ideas as they come popping out of your brain. Be as detailed as you can be. You will thank yourself later.

Even if you don't already have a backlog of ideas jostling for your attention in the lab, it's still a good idea to keep a log and explore the things that interest you. Leonardo da Vinci kept detailed notebooks on almost every possible subject. Anything that interested him got written down, sketched, or diagrammed in his notes. Even today, people are still getting inspiration from his doodles (see Figure 1-1).

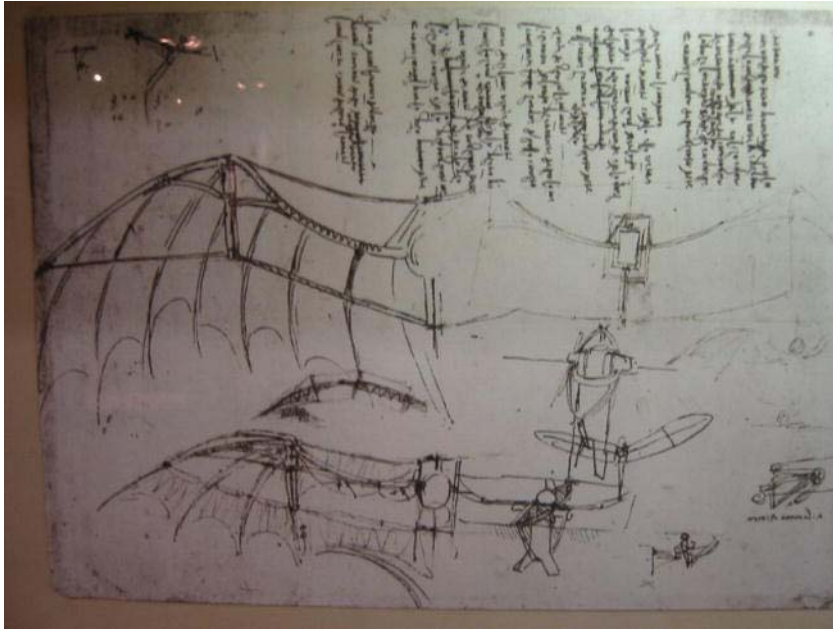

Figure 1-1. Sketches and notes for a “flying machine” by Leonardo da Vinci. Photograph by Arnaud 25 (public domain), via Wikimedia Commons.

Writing down your ideas also helps you pick which projects you want to work on first. It just isn't possible to work on all of them at the same time! Narrowing down the list helps get you focused and lets you concentrate all of your talents and energies on the most important projects.

When you're just beginning, the “most important projects” are the ones that provide the most positive reinforcement in the shortest amount of time. Plan a few simple, straightforward projects with a high probability of success at first. You can become more ambitious and take greater risks when you've built up a good reserve of self-confidence and techniques. Remember, the only experiments that fail are the ones from which you don't learn anything. Sometimes learning how *not* to do something is just as important as learning how to do it correctly.

Goals

The best way to turn great ideas into spectacular projects is to have a plan. Set some achievable goals for yourself. When you're first starting, don't be afraid to take those baby steps. You have to crawl before you can teleport.

Project planning is its own art form, and a dark and mysterious art it can be sometimes. It really helps to have clearly defined goals and expectations early in a project. Otherwise, how will you know when you're finished?

Any large, complex problem or project can be broken down into smaller, more manageable subprojects. Unfortunately, this can be carried too far. You don't need to reinvent the wheel every time you start a new project. There's a saying that suggests, “Don't build anything you can buy.” The counterpoint to this wisdom is the equally ancient saying, “Don't buy what you can build.” You'll have to be the judge as to which one applies best to you and your situation.

Do you have lots of time and very little money? This is good news! This helps simplify the decision-making process enormously. Design and build everything yourself, from scratch. This can include your own tools as well as custom-made components. The trick to this approach is not get lost in all the inevitable details that will arise.

No time to spare, but there's a bit of a budget available? This is likewise good news. With few exceptions, there's someone out there that's willing to part with just what you need for a reasonable price. The trick here is to find them and make that connection.

Inspiration!

Remind yourself what your inspiration is. What initially prompted you to start thinking about building your own electronics lab? Why did you want to get into electronics as a hobby or a career in the first place? Do you even remember?

It really helps to have a firm grasp on what your underlying motives are (or were) when faced with the challenges that regularly present themselves along the way. While it's true that some things just need doing, does it really have to be *you* that does them? Could you farm out some of the work and still feel a sense of satisfaction in the completion of the project? Or do you feel the need to take the do-it-yourself mind frame to its utmost limit?

Whatever your inspiration is, or wherever it came from, do your best to keep it in your sights while pursuing your dreams and goals. It makes it that much more satisfying when you eventually attain them.

How Electricity Works

There are two ways to go about learning how electricity actually works. The first involves just a whole bunch of *fascinating* theoretical information about atoms, electrons, fairies, and dragons. The second way is to just assume that it does indeed work, and spend some time actually putting it to work.

You don't need to know everything about electricity to have fun with it. A passing understanding is sufficient to get you started. As your technical requirements grow more elaborate, you will find yourself going back to revisit some of the basic concepts, until your comprehension is sufficient to carry you forward.

The Theoretical Approach

The prevailing theories about how electricity works center around the orbits of negatively charged subatomic particles called *electrons*. Electrons are quite small, even when compared to individual atoms. Electrons normally whiz around the *nucleus* of the atom, which is usually made up of other subatomic particles called *protons* and *neutrons*. The exception is hydrogen, whose most common isotope has only a single proton and no neutrons. Protons have a positive electrical charge and neutrons have no electrical charge.

When an atom has a balance of protons and electrons, it is said to be electrically neutral. If an atom has more electrons than protons, it has a negative electrical charge. Conversely, if there are more protons than electrons, the atom has a positive charge. An atom that has either a positive or negative electrical charge is called an *ion*.

While flying round and round the nucleus, electrons tend to cluster into well-defined orbits, or *shells*. The innermost shell of an atom can hold as many as 2 electrons. Once this orbit is "full," up to 8 more electrons can be accommodated in the next larger shell. The next shell holds up to 18 electrons, and the one after that can contain up to 32 electrons. After that, the shells get smaller again, stepping back down symmetrically from 18 to 8 to 2.

Each unique combination of electrons and protons represents one of the chemically distinct *elements*. Each element has its own particular chemical characteristics, and cannot be further subdivided by conventional chemical or mechanical means. Toward the end of the *periodic table*, which arranges all the known elements into meaningful rows and columns, you'll start to find some exceptions to the shell symmetry. These heavier elements, however, don't usually turn up in most electronics labs, so we'll not be spending a lot of time there.

Individual atoms can combine into more complex structures called *molecules*. One popular molecule is water, which is made up of two hydrogen atoms and one oxygen atom. Each of the hydrogen atoms has a single electron. The oxygen atom has eight electrons. The first two electrons in the oxygen atom occupy the first shell, leaving six electrons in the next outer shell. That leaves two "open" places in the second shell, which is where the two electrons from the two hydrogen atoms come into play. The electrons are shared by the three atoms, linking them all together and forming a *covalent bond*. Water has vastly different physical properties than either hydrogen or oxygen.

It's also possible to bump an electron out of orbit around a nucleus. When this happens, the atom becomes an ion and is electrically positive. This makes it especially attractive to any loose electrons that happen to be in the vicinity. This is because electrons are negatively charged, and in the case of electrical charges, opposites attract. This movement of electrons is how an electric charge flows through a substance.

Some materials are very good at slinging those electrons around, and as such are called good *conductors* of electrical energy. Examples of good conductors are copper and silver. Some materials resist the flow of electrical charge, and can be used as *insulators*.

An important concept to understand about the flow of electricity is that it is based on the movements of tiny, *negatively charged particles*. This is referred to as the flow of *electron current*, but this term is rarely used. For some reason, the more popular, or conventional, idea of electric current flow is from the more positive point to the more negative point in a circuit. This is referred to as *conventional current* and is the standard used throughout this book.

The fairies and the dragons come into the picture when you start to look any deeper into how the building blocks of matter are actually (or allegedly) constituted. The previous quick summary of how electricity works covers less than 1 percent of the physics needed to understand even how basic atomic principles operate. Even then there are various schools of thought as to how, *exactly*, all that tiny stuff works together to produce rainbows and cousins and moon rocks. A proton, once thought to be an indivisible *elementary particle*, is now thought to be built out of a "down" quark and two "up" quarks. There are also "strange" and "charmed" quarks flitting about, along with an entire pantheon of mythological particles. Go figure.

Now all of that *fascinating* information only scratched the surface of how *electricity* works. Electricity does a lot of work for us. We use it for lighting, heating, motion; just all kinds of things. *Electronics* is where we start to get into some really bizarre physics involving semiconductors, transistors, computer chips, and other miracles of the modern age. Explaining even the basic ideas about how *electronics* works is way beyond the scope of this little book. It's certainly possible to learn and understand it, but for the purposes of setting up a lab and building some example projects, we can just assume that it does indeed work. We can start from there and have some fun with it.

If your curious mind just can't stand *not knowing* how electronics works, the interwebs are your friends, and so are the helpful folks at your local library.

A Practical Approach

An easier way to think about electricity is to skip over *why* it flows and concentrate on *how* it flows. That's what we'll be doing in the remainder of this book, for the most part.

■ **Note** Electricity flows in a circle.

Any continuous flow of electrical current travels in a circle. There are exceptions to this broad generalization, but most of the example circuits encountered in this book will have a definite circular arrangement, if you know how to look for it.

Here are some technical terms that will be used throughout this book. You don't have to memorize any of them right now (there will *not* be a test), but you should at least take a glance at them so you know where to come back when you want to know more.

Circuit: A circuit is anything that forms a continuous loop or circle. The term *circuit* is formed from the same Latin word that means *circle* or *wheel*.

Amps: The *intensity* of an electrical current is measured in units called *amperes*, named after André-Marie Ampère. This is usually shortened to *amp* in popular usage. The symbol for amperage in a circuit is *I* (for intensity), while the unit is abbreviated *A*. For example, you could say that the intensity of the electrical current (*I*) in a circuit was measured to be 3.75A (amperes). Electrical current is measured with an *ammeter*.

Volts: The voltage in a circuit is the measure of the difference in electrical *potential*, or how much work it *could* do. The unit of voltage is the volt (V), named after Alessandro Volta. This is sometimes referred to as pressure or tension. For example, a “high-tension wire” means a high-voltage line, not necessarily one that has been pulled really, really tight. Voltage is, not surprisingly, measured with a *voltmeter*.

Watts: Electrical power is measured in watts (W), named after James Watt. The easy way to calculate watts, or the amount of energy that is converted into work (either useful or not) is to multiply the voltage across the circuit by the current flowing through the circuit. For example, if a 12V battery is connected to a lightbulb that draws 2A, the bulb converts the electrical energy into both light and heat (mostly heat) to the tune of 24W ($12V \times 2A = 24W$).

Ohms: The resistance to the flow of electrical current is measured in *ohms*, named after Georg Ohm. A *resistor* is a simple electronic component that exhibits a fixed resistance to the flow of electrical current. The symbol for resistance is *R* and the unit of measure is the capital Greek letter omega, Ω .

Safety

Make no mistake: electricity can kill you. It bears repeating, as well as emphasis.

■ **Warning** Electricity can kill you.

Working safely with electricity is like working safely with a sharp knife, for example. A good knife is a useful tool. Life would be cumbersome and crude (not to mention short) without good tools. However, when using *any* tools it's important to understand their proper use and operation. The same goes for electricity.

The point here is not to be overdramatic about the dangers of electricity. Billions of people are safely and peacefully coexisting with electricity, largely due to wise safety rules and well-designed electrical appliances. However, there are three major ways that you can be harmed when working around electricity, and it is important that you be aware of them:

- Your body uses tiny amounts of electricity to send nerve impulses to and from your brain. Sending relatively giant shocks of electricity through your body is a good way to stop your heart from beating or your lungs from breathing. You need to keep doing both of those things, so be careful.
- Since your body is not a very good conductor of electricity, it converts the electrical current into heat, which can produce very damaging burns, both on the inside and the outside of your body.
- Additionally, many electrically related injuries are sustained while trying to *get away* (i.e., your body's involuntary reflex when exposed to dangerous voltages).

Yet working safely with electricity is easy. Observe the following rules and you'll be relatively safe, both in your lab and outside of it:

- Always assume a circuit is "live." Electrical devices can retain lethal voltages even when completely disconnected from power.
- Don't work with high voltage (more than 36 volts) unless you're specifically trained. Reading this book does *not* mean you're "specifically trained," even if you read it *twice*.
- Don't short-circuit batteries (i.e., deliberately connect the positive and negative terminals together). Even very small batteries can hold dangerous amounts of power and can produce enough heat to burn you. Even worse, it can start a fire, which is yet another unpleasant way to die.
- Be careful when using metal (conductive) tools around battery terminals so that you don't accidentally short the terminals together or to other circuitry.
- Don't assume other people are aware of these dangers.

Lighten Up!

Now it's time to have a little fun with electricity, don't you think? While it's important to keep safety in mind, it's just as important to be curious and willing to try new things. Don't let the (important) safety rules immobilize your creativity. Use these rules, like any tool, to leverage your enjoyment of this fun and exciting hobby.

Let's start with a simple circuit that is almost guaranteed to lighten things up. Let's take apart a flashlight (or *torch* for you metric types) and see how it works.

First, find a typical household flashlight. The flashlight in Figure 1-2 was purchased for \$3, and it included two new D-cell batteries. Put the batteries in the flashlight and make sure it lights up when you turn on the switch. If the bulb is burned out or the batteries are dead, then this experiment is not going to be much fun at all.



Figure 1-2. A typical household flashlight will be the ~~victim~~ subject of our first electrical experiment.

Once we've established that the flashlight works as intended, we can begin the experiment.

DISSECTING A FLASHLIGHT

We don't need most of the pieces of the flashlight body. Let's take it apart and have a look inside.

1. Open the flashlight by unscrewing the end with the lightbulb in it.
2. Remove the batteries. Set them aside for the moment. We'll use them in a bit.
3. Remove the plastic retainer that holds the bulb in the reflector.
4. Take out the bulb.
5. We'll need to replace the wiring that was contained within the flashlight's body. Find a short piece of wire 8" to 12" long. A specialized jumper wire with alligator clips on the end was used in the photos for this exercise, but almost any kind of wire will do. See Figure 1-3.



Figure 1-3. All the pieces you'll need to light up the bulb.

6. If you're using plain, insulated wire, you'll need to remove a small bit of it from both ends of the wire to expose the *conductor*, or metal wire part inside.
7. This step can be tricky. Try to hold both batteries in one hand, along with the bulb. The batteries need to be pointed in the same direction. If this is too hard to do, try it with just one battery.

8. The positive end of the battery has a small cap on it. Touch the bottom point of the bulb to the top of the battery.
9. Now, using your other hand, connect the wire from the bottom of the battery to the metal base of the bulb.
10. The lightbulb should start to glow. See Figure 1-4.

■ **Caution** If you have a super-bright bulb, it can get hot. Don't burn yourself!



Figure 1-4. The completed circuit, showing the glowing bulb. Electricity is flowing!

Several important things are going on in this very simple circuit. Electrical current is flowing, producing useful work (in this case, light). Can you see the “circle”? When you *break* the circuit, the bulb stops glowing. This is exactly how the switch in the flashlight body works. Peek inside the flashlight and see if you can tell how it works. By connecting and disconnecting the wire, you can make the bulb flash. If you only use one battery, the bulb turns on, but is not as bright. Why do you think that happens?

Environmental Impact

You affect your environment every day, and your environment affects you, as well. As you learn more about electronics and all the interesting and wonderful things it can teach you, be mindful of what kind of trail you're leaving behind for others to clean up.

A good way to get a feel for your environmental impact is to take a look at your garbage. It doesn't sound that interesting or fun, but it *will* teach you a lot about yourself and your habits. What are you throwing away? Could you have found either another use for it, or perhaps another home? Is it going to be a nuisance to someone else, or even worse, a hazard?

A good example is the use of “disposable” batteries. We used batteries (technically *cells*, but that distinction will be spelled out in more detail in Chapter 3) in our very first experiment. We buy new batteries and plug them into our devices, and when they run out of power we take them out and throw them away. Where do they go? How do they then interact with the environment? They don't just “go away.”

Disposable batteries are very convenient. They are generally inexpensive, compact, self-contained, and reliable. This *convenience*, however, comes with a price all its own. Consider using *rechargeable* batteries whenever possible in your lab. They cost a little more than their disposable counterparts, but can easily and cheaply be refilled with electrical goodness over and over again.

You should also be aware of any hazardous materials that you use or store in your lab. For example, lead is a very common material used in many electrical devices, even though its use is being reduced worldwide. It is found in older-technology rechargeable batteries, solder, and printed circuit boards.

Some of the chemicals used to etch printed circuit boards can be dangerous if not used, stored, and disposed of properly. Take the time to understand what, exactly, you're working with when you're conducting your experiments in your laboratory.

Just like the captain of a seagoing vessel, you're in charge of what happens in *your* lab. With this authority come important responsibilities that rest squarely upon your shoulders. Please take these responsibilities seriously.

Budgeting

How much is all this stuff going to cost? A lot of it depends on how creative you want to be in stocking your lab with tools and parts.

If your budget is small, then start small. If your budget is nonexistent, then you'll just have to start even smaller. You should generally approach acquisitions for your lab under one of these three headings:

- Buying new
- Finding used
- Harvesting or recycling

Buying New

Buying everything new is obviously the most expensive approach, at least from the *money* side of it. What a lot of people fail to take into account is that their *time* is also a very valuable commodity. Try to balance the one with the other, as befits your particular situation.

Except for the folks in the most *dreadful* of hurries, it always makes sense to shop around for the tools, equipment, and components that you are going to need in your lab. You'll find that a lot of “professional-grade” equipment carries an enormous price premium compared with “consumer-” or

“hobby-grade” alternatives. This is generally to be blamed on the fact that there is a correspondingly enormous amount of money to be made in the field of electronics.

New components are almost always more desirable to use, especially when you’re looking at a production environment and you need to make sure everything produced is of the highest possible quality and reliability. New, unused components are also more appropriate when conducting complex experiments, as this helps to reduce, if not eliminate, many variables in the testing and analysis phases. You don’t have to worry that someone (probably you) might have “borrowed” some parts for a quick fix or some other temporary usage and then surreptitiously replaced them back in inventory, having possibly compromised them in some unseen way.

Finding Used

A prudent way to fill up a new lab, especially when first starting out, is to look for bargains on used tools and components. This is especially true of the fixtures, shelves, cabinets, benches, and other furniture that belongs in a lab.

Tools wear out. Tools are replaced. This is a fact of life when you’re in the business of working with tools. The good news is that “one man’s trash is another man’s treasure.” If we consider the possibility of women participating, we get three more potential combinations, all of which can end up in a win-win situation.

Many used tools can be retrofitted and placed back into service in your lab. On the other hand, there are a lot of tools that are simply used up and can not feasibly be brought back into useful service. Either their repair is cost prohibitive or they are no longer supported by their original manufacturers.

Another factor working in favor of the patient and observant collector of discarded tools is the inevitable march of progress. What was shiny and top-of-the-line a year ago might be intolerable or insufficient next year, from the standpoint of the original purchaser. Many bargain opportunities arise from this simple understanding.

This can sometimes be applied to the purchase of components that have never been used, but have been sitting somewhere waiting for their chance. A commonly used phrase to describe these parts, which are often sold at a discount, is *new old stock (NOS)*. Sometimes these parts are sold this way because of overstock or because a manufacturing run was cancelled or cut short.

Harvesting or Recycling

There’s an absurdly large amount of perfectly good equipment, tooling, fixtures, and components sitting out there, looking for a new home. A lot of companies, as well as individuals, either outgrow their present fittings or turn toward other interests and endeavors. This can be an excellent opportunity to acquire the furnishings you need to populate your lab.

On the other hand, please don’t go crazy. You don’t have to pick up every discarded appliance or chair you see sitting by the roadside. Why pay rent for something you can easily and cheaply obtain when you actually need it? Are you really wanting to pay the heating and air-conditioning bill for that box full of odd-sized capacitors that are probably past their prime? Don’t fall into the trap of the *false economy* when it comes to bargain-hunting for your lab. The most important ingredient in your lab is *you*. Leave a little room to move around a bit.

Another factor to keep in mind is *shelf life*. Not all parts (or tools) last forever, especially when not being used. Batteries are the worst. You can prolong the shelf life of nonrechargeable batteries by storing them in your refrigerator, as this slows down the electrochemical processes within them that produce the electricity. Even solar panels will wear out with either constant use or constant disuse, although this can take years to happen.

Some Example Workshops

Here's a little peek into some actual electronic laboratories, each with its own personality and history. Each one grew from something small into something, well, not so small.

A Fresh Start

Harold Timmis is an electronic engineer, software developer, and author. His curiosity about how things worked started as a small child, which led him from taking apart everything in his parents' house to studying engineering at the Florida Institute of Technology.

Harold keeps a lab in his home where he can work on gadgets in his spare time. Harold recently moved, and used the opportunity to “clean house” and set up everything in his lab exactly the way he wanted things.

He took this photo of his new lab after working on a couple of projects (see Figure 1-5). Note that everything is within easy reach when sitting at the desk. It's still quite tidy, as you can see.



Figure 1-5. The reorganized home lab of Harold Timmis (photo by Harold Timmis)

The Robot Clubhouse

The Dallas Personal Robotics Group (<http://dprg.org>) is the world's oldest personal robotics group known to man. From 2002 to 2009, Mike Dodson of Modern Assemblies donated the use of a portion of one of his warehouses to DPRG. This gave DPRG a permanent home for meetings, contests, and social gatherings.

Robot builders enjoyed a spacious and comfortable area for working on robot projects, among other pursuits. Over the years, members contributed time, equipment, and lots of hard work to improving the space. The photo in Figure 1-6 shows one end of the available space, after an extensive remodeling. Several workstations along the wall are in the process of being set up. That good-looking fellow seated at the table is the author.

When Mike retired in 2009, DPRG began a search for another home.



Figure 1-6. DPRG's world headquarters from 2002 to 2009 (photo by R. Steve Rainwater)

A Cautionary Tale

It's relatively easy to go from a well-designed and effective lab to something, let's say, less desirable. This doesn't happen overnight, but it can happen. Let this be a warning to you about how even the best of intentions can still produce embarrassing and unproductive confusion (see Figure 1-7).

Unfinished projects and leftover parts and tools compete for the limited space available in this photo. Not only is a lot of time wasted in searching for both components and tools, but the limited space restricts the scale of projects that can be entertained.

Don't let this happen to you.



Figure 1-7. It's not safe. It's not pretty. It's not even properly "eccentric." You have been warned.

Summary

So now you know a little something about electricity and electronics. Hopefully this chapter has covered your very basic questions about how all this magic stuff actually works.

Now you're ready to start poking around some circuits. You're going to need the right tools for the job. Chapter 2 will get you started. You'll learn about some basic hand tools that are very useful in the lab, as well as some fairly high-tech machines that you might require in the future.

Building Your Tool Chest

You're going to need some tools in your lab, as well as the skills to use them effectively. This chapter will get you started. If you're starting from scratch, don't worry. There's not a whole lot you absolutely *must* have to get started. Some basic hand tools and a place to keep them organized is all you will need. You don't even have to spend a lot of money at first. As you progress in your hobby, you will most likely want to add to your tool chest and upgrade some of those tools. Electronics can be the perfect hobby because it can take up (1) all your spare time and (2) all of your discretionary income. What more could you ask?

The very basic hand tools, such as screwdrivers and tweezers, are mostly self-evident in their usage. Try not to poke yourself in the eye. Where some helpful advice is appropriate, it will be given.

Here's an excellent example of a simple safety rule that will absolutely improve and extend your life: when using any kind of cutting tool, always direct the cutting motion away from yourself. For example, you might receive a package in the mail, and get all excited about opening it. You then discover it's sealed up with indestructible packing tape and can't simply be ripped open with your bare hands. Use a small knife or box cutter and make a single cut at a time, starting from the point closest to you on the package and cutting outward. Using this method, should the knife slip for any reason, the blade will travel away from you. This allows your blood and other bits to stay inside you, where they can do the most good. Never cut toward yourself.

If you've already got some tools (or even a *lot* of tools), it never hurts to review their proper usage. Also, if you're suffering from an *overabundance* of tools, to the point where you can no longer keep them organized, this chapter might help you to prioritize them, at least as far as permanent residency in your lab is concerned.

■ **Tip** Every tool in your shop must *earn* its place there. It must *deserve* to be there. *No exceptions.*

The Most Important Tool Ever

The most important tool you'll ever use is your mind. Every other tool you will ever work with depends on the correct and proper functioning of your mind. If you're careful with it, you won't misplace it, neglect it, damage it, or use it for the wrong job. Your mind is a wonderful asset when cared for properly, and a terrible liability when ill-treated.

Your mind is in many ways like a muscle. The more you use it, the stronger it gets. Learning new things does not "push out" the old things you've already learned. Your brain is capable of forging new neural pathways when challenged, and there's plenty of extra capacity in that old noggin of yours to handle whatever may arise.

■ **Tip** Try to learn something new every day.

Take care of that brain of yours. Just like you wouldn't use a dull drill bit or a rusty saw, don't try to work on electrical or electronic projects when your mind is not in the right place. Ideally, you should never try to get any work done in your lab when you are sleepy, distracted, angry, upset, medicated, or overly tired. Deal with whatever problems you're facing in a responsible manner and then get back to work in the lab.

- Are you sleepy? Take a nap or head off to bed for the night. Really bad mistakes are made when the brain does not get enough sleep. Sleep deprivation is notorious for being obvious (and obnoxious!) to everyone else except you. "Really bad mistakes" made while working with electrical or electronic projects can produce very hazardous conditions for you and everyone around you, such as fire, damaged equipment, injuries, and even death.
- Are you angry or upset? Then your mind is not going to be adequately focused on what you need to do in the lab. "Fools! I'll destroy them all!" are famous last words *for a reason*. Give yourself some time to calm down from whatever has angered or upset you. Also, it's OK for you to give yourself permission to admit that you are angry or upset about something in the first place. Ignoring it probably won't make it go away, and probably won't make your feelings about it go away, either. Walk away, count to ten, or whatever works for you.
- Feeling distracted? Then now is *not* the time to be conducting electronic experiments in the lab. You need to be *present* in the lab, both bodily and mentally. There are just too many ways to make simple blunders that have far-reaching and sometimes overly expensive consequences.
- Have your cognitive functions been compromised? This can happen from taking certain medicines or even recreational intoxicants. If the little bottle says, "Don't operate machinery or drive an automobile," then you probably shouldn't be making important decisions or working with dangerous circuits in your lab, either. Wait until you're clear-headed enough to proceed with your plan for world domination, adding blinking eyes to a plush doll, or what have you.

The worst thing about cognitive impairment is that the first thing that gets impaired is the ability to judge the level of your cognitive impairment!

Care and Feeding of Your Brain

Here are a few tips to keep your brain (and the rest of you) in good working order:

- Stay hydrated. Drink more water than you think you need. This might result in more trips to the bathroom, but this is much more desirable than the alternative. A good flow of water through your systems helps your body feed and repair itself, as well as aiding in the elimination of toxins. Drink more water.
- Avoid excess consumption of coffee, tea, sodas, and especially “energy” drinks. These contain ingredients that stress both your body and your mental capacity. They do not contain energy, but trick your body into going into overdrive by triggering a stress reaction.
- Take frequent breaks. Get up and walk around, if possible. Raise your arms over your head and hold them there as you count to ten. This redirects blood flow and helps restore a balance within your peripherals.

All Those Other Bits, Too

Just as your mind is the most important tool you’ll ever use, the rest of your bodily bits and personal pieces are vital and important in your work in the lab. For the most part, there are no spare parts laying around for things like your eyes, your ears, your hands, or your skin.

Should you wear eye protection in the lab? Yes, you should. Are you always going to do so? Probably not. It’s true, it can be inconvenient or perhaps a tad uncomfortable. Consider the cost, however. Even the tiniest scratch on your eyeball can take weeks to heal and leave you susceptible to infection or vision loss. It’s just not worth it to be lazy. Ask the next one-eyed person you see. If you’re a bit uncomfortable asking one-eyed people, “Hey, what’s with the one eye?” then perhaps you can just try to imagine them advocating or encouraging you along the same path they took, whether intentionally or accidentally. They won’t do it.

Invest in quality eye protection that is comfortable and properly sized for you. Provide eye protection for visitors to your lab as well, if they will be present when soldering, welding, machine tooling, or wire clipping is being performed. Then invest in the habit of wearing your eye protection whenever it is appropriate.

■ **Note** Don’t pretend that your prescription glasses with polycarbonate lenses are “safety glasses.” They aren’t. They do not protect either your eyes or your face from impact or objects entering from the side, as proper safety glasses should. If you usually wear glasses, use safety glasses that comfortably accommodate your glasses when worn.

Will you be working with really loud noises? These could be from powerful audio amplifiers (“it goes to 11”) or power tools. Hearing loss from exposure to excessively loud noises is cumulative. This means it slowly (or suddenly) chips away at your hearing, bit by bit. Why do you think old people turn up the TV so loud?

Hearing protection is both affordable and comfortable. For temporary protection, you can use disposable earplugs. If you need protection all day, consider earmuffs designed for hearing protection. Don't let "Hey, y'all, check this out" be the last thing you ever hear.

It's hard to work with hand tools with no hands. It's possible; just really hard. Take care of your hands. There are a hundred ways to burn, tear, cut, or otherwise mangle those mitten-fittings of yours. Have a variety of work gloves on hand to handle the different needs of your lab. The choice will be ultimately determined by the particular hazards present in your lab. Are you working with chemicals as well as electronics? How about sharp edges or glassware? Normally, you won't need to wear gloves for soldering small electronics, but if you start working with really large-scale projects, such as sculptures or plumbing, you might.

Make sure you are still "handy" when wearing the proper gloves for the job. Make sure the gloves fit you properly and allow you the adequate dexterity you need.

■ **Tip** Be safe. Don't be lazy.

Basic Hand Tools

Assuming that you're going to start small and build toward bigger things, you should also start small with some small hand tools. These tools will make it much easier to work on small parts and wires.

Good hand tools increase your effective strength and improve the accuracy and precision of your motions. They allow you to focus a great deal of your strength on exactly the part that needs it, without wasting a lot of effort. Good hand tools also insulate you from sharp, hot, or otherwise unpleasant objects when you work on them.

Take care of your hand tools. Put them up when you're done with them. Make sure they are clean and ready to be used again the next time you need them. Few things are more frustrating than attempting to start a quick repair job and finding out that you need to spend twice as much time preparing your tools for use.

Have some sort of methodical plan or reasoning involved with the storage of your tools. They need a safe and comfortable home, just like you do. You need to be able to find them quickly when you want them. Try out different organizational strategies until you find one that works for you and your lab. This is an easy task when you have just a few tools to organize. Once you've accumulated a large collection of hand tools, this is no longer optional. You *must* know what tools are available and where they are located.

Frequently used tools should be within easy reach of your primary workstation. If your tools need any sort of adjustment or setup before use, make sure you've got all the proper bits handy. For example, a drill press will often have a chuck key used to tighten and loosen the chuck that holds a drill bit in place. That key needs to be in the immediate vicinity of the drill press, as well as easy to locate. Don't spend a lot of time needlessly hunting for tools. Decide for yourself on some safe and practical policies for where you keep your tools.

■ **Tip** Don't waste time guessing where your tools are located. *Decide* where they are located.

Just like everything else, hand tools have a limited useful lifetime. While some tools can easily outlast you, it's up to you to keep track of exactly how much utility you can continue to expect from your tools. This doesn't mean that you have to trash your hand tools once they develop some tiny flaw. If it's beyond your capabilities to repair the tool, then consider replacing it and reassigning it to the second string or backup tool chest. Having a spare tool, even a slightly imperfect one, on hand when you need it can make the difference between success and failure in a project.

Bear in mind, however, that some tools are simply too dangerous to keep around once they've outlived their useful life span. A dull cutting tool that cannot be reasonably resharpened is a good example of a tool that has lost its honored place among your other tools. Thank it for its service, wipe away that little tear, and then figure out a good way to recycle any of its bits that are still functional.

Wire Cutters and Wire Strippers

As you might have picked up from Chapter 1, you can spend a lot of time working with wire in this hobby. Understanding a little bit about how wire is made and how it functions in a circuit will aid you in your experiments.

How Wire is Made—The Very Short Version

Most wire is made of copper or a copper alloy. Some wire used for electrical wiring in houses is made of aluminum. The wire itself starts out as a fairly thick strand and is stretched and pulled—a process called *drawing*—until the desired diameter is obtained. This strand is then wrapped up on spools or bobbins.

- Some wire is made of a single strand of copper (or aluminum). This is called *solid-core* or *single-strand* wire. It is a single strand of wire, usually circular in cross-section.
- Multiple, thinner strands of wire are often bundled or twisted together to make larger-diameter wire. Stranded wire is much more flexible than solid-core wire, but is more expensive to produce because of the extra manufacturing steps required. Because stranded wire has a larger surface area per unit of length, it is more susceptible to environmental hazards such as corrosion.

Most electrical wire is covered with an insulating jacket, usually made of plastic or rubber. This sheathing must be removed to make electrical connections. There is sometimes more than one layer of insulation on a wire, depending on what its final application is destined to be.

More information about wire as a *component* will be presented in Chapter 3. For now, the emphasis is on the characteristics of wire that help determine the best tools to use when working with wire.

Selecting the Correct Tool

Both copper and the aluminum alloys used for electrical wiring are fairly soft metals and can be easily cut or formed with simple hand tools. Wire *cutters* are specialized tools made to make a clean cut through the wire's strand or stands. Wire *strippers* are another kind of specialized tool used to remove the insulation from a wire.

Figure 2-1 shows two rows of commonly available wire cutters.



Figure 2-1. Commonly available wire-cutting tools. The top row shows three styles of diagonal cutters, which are the preferred tools for cutting small-gauge copper wire. The bottom row shows some tools that offer wire cutting as a secondary facility, and should only be used when proper wire cutters are not available.

The top row of cutting implements in Figure 2-1 are various forms of what are known as diagonal cutters, side cutters, or flush cutters. These cutters have beveled cutting edges that meet in the middle of the wire being cut. One side of the cutters is flat, or *flush*, allowing wires to be cut with some precision. These are the preferred cutters for small-gauge copper wire, as well as for clipping excess component leads from a printed circuit board (PCB). See Figure 2-2.

Compare the cutting action of the side cutters to the other, less optimized wire cutters in the second row of cutters in Figure 2-1. These cutters either use a shearing action to cut the wire or include a flush-cutting area as a secondary feature.



Figure 2-2. A close-up look at the business end of a pair of side cutters. When the two cutting edges meet in the middle, the bottom side is flat, or flush, allowing the user to get quite close to where a wire or component lead emerges from a solder joint.

Use caution when clipping component leads or small wires with any wire cutters. The cut lead can easily fly away at sufficient velocity to poke you right in the eye or other sensitive area. If possible, hold *both* ends of a wire being cut or direct the cut leads *away* from your face.

■ **Caution** Use eye protection when clipping leads. Don't say you weren't warned about this hazard.

Wire Strippers

Wire strippers are tools that allow you to easily strip the nonconductive insulation from wires. You can try chewing it off with your remaining teeth, but this is not recommended.

Wire strippers usually consist of a pair of hinged blades with some sort of machined notch. The notch allows the blades to cut the insulation around the wire without cutting or nicking the underlying conductor. A good example is shown in Figure 2-3.



Figure 2-3. The popular T-Stripper combination wire cutter and stripper tool from Ideal Industries has been around for over half a century. Note the wire gauge sizes stamped into the face of the cutter blade. New models feature laser-engraved text.

The wire strippers in Figure 2-3 can easily strip the insulation from wires with a conductor diameter, or *gauge*, between 16 (0.0508" or 1.291 mm) and 26 (0.0159" or 0.405 mm). The higher-numbered wire gauges represent *smaller*-diameter wires. Once upon a time, the gauge number represented the number of *drawing* operations that were performed on a wire when being manufactured. The more times it was drawn through the processing equipment, the thinner the wire became. Today, the wire-manufacturing industry in the United States and Canada has adopted the American Wire Gauge standard (AWG). See Table 2-1.

Table 2-1. The AWG. A more complete listing is available at http://en.wikipedia.org/wiki/American_wire_gauge, from which this partial list was obtained.

AWG	Diameter Area		mm ²	Copper Resistance		
	Inch	mm		Ω/km m Ω/m	$\Omega/1000\text{ ft}$ m Ω/ft	
0000 (4/0)	0.46	11.684	107	0.1608	0.04901	
000 (3/0)	0.4096	10.404	85.0	0.20	28	0.06180
00 (2/0)	0.3648	9.266	67.4	0.25	57	0.07793
0 (1/0)	0.3249	8.252	53.5	0.32	24	0.09827
1	0.28	7.348	42.4	0.40	66	0.1239
2	0.25	6.544	33.6	0.51	27	0.1563
3	0.22	5.827	26.7	0.64	65	0.1970
4	0.20	5.189	21.2	0.81	52	0.2485
5	0.18	4.621	16.8	1.02	8	0.3133
6	0.16	4.115	13.3	1.29	6	0.3951
7	0.14	3.665	10.5	1.63	4	0.4982
8	0.12	3.264	8.37	2.06	1	0.6282
10	0.10	2.588	5.26	3.27	7	0.9989
12	0.08	2.053	3.31	5.21	1	1.588
14	0.06	1.628	2.08	8.23	6	2.525
16	0.05	1.291	1.31	13.1	7	4.016
18	0.04	1.024	0.823	20.9	5	6.385
20	0.03	0.812	0.518	33.3	1	10.15

22	0.02	53	0.644	0.326	52.9	6	16.14	
24	0.02	01	0.511	0.205	84.2	2	25.67	
26	0.01	59	0.405	0.129	133.9		40.81	
28		0.0126	0.32	1	0.0810	212.	9	64.90
30		0.0100	0.25	5	0.0509	338.	6	103.2

We'll return to this table again in Chapter 3 when the electrical properties of wire are discussed. For now, note that as the wire gauge number goes *up*, the wire's physical diameter goes *down*. Similarly, as a conductor's physical size goes down, its ability to carry current also goes down, and its electrical *resistance* goes up.

■ **Note** Other standards exist throughout the world. Steel-wire manufacturers use a different scale, as their interest is more on the tensile strength of the wire, not its electrical properties.

Note that the AWG is for single-strand copper wire. Equivalent gauges in stranded wire are physically a bit larger, although they have the same effective cross-sectional area and can carry the same amount of current.

When using wire strippers, keep in mind that your goal is to cut and remove only the nonconductive insulation from the wire, leaving the internal conductor intact. Even a small nick can result in a weak point in the wire, both electrically and mechanically.

Practice Makes Perfect

The best way to attain proficiency with a new tool is with practice—lots and lots of practice. This is true for working with your hands as well as with that big brain of yours. Ideally, any task worth doing will involve at least a little bit of both manual dexterity and focused brain power.

Cutting and stripping wires is an excellent example. For your first practice assignment, spend some time turning long, beautiful lengths of wire into little bits of wire with stripped ends.

CUTTING AND STRIPPING WIRE

For this exercise, you're going to need the following:

- Wire cutters
- Wire strippers
- Much wire
- A comfortable, well-lit location

Cut the Wire into Segments

Don't watch TV or be otherwise distracted. Pay attention to what you are doing.

Begin by cutting the wire into various-sized segments from 2" to 6" in length. Accuracy in length is not critical at this point. You need to get a good feel for your wire cutters and how much force is needed to cut the wire, without cutting yourself or others.

Collect the cut wire segments into a bowl or small container for the next step.

Strip the Wire Segments

Using your wire strippers, remove about 1/4" (6 mm) of insulation from both ends of each wire. Try not to cut or nick the wire core. The insulation that you remove can either be discarded or collected for use in some sort of art or craft project.

Once you've completed the cutting and stripping portion of this exercise, sort the wires according to their length, or their color if you used different colors of wire. Compare the quality and consistency of your work by looking at the first few wires and the last ones you did. Do you see any improvements in your work?

If you spend about an hour working on your wire-cutting and wire-stripping technique, you will perhaps master a skill that will prove useful for the rest of your life, as well as prepare a big pile of wires that you can use in many of the sample projects illustrated in this book.

Pliers and Tweezers

Every day, the size of the "typical" electronic component gets smaller and smaller. This miniaturization process has brought about a world where you can carry a phenomenally powerful computer in your pocket, and sometimes even make phone calls with it. The individual transistors, resistors, capacitors, and other components inside such modern marvels are literally microscopic in size. You need a fairly powerful microscope to be able to see them at all.

In your typical home electronics lab, and even in many professional labs, you will not be dealing with these tiny things, except as large clumps all tied together inside a chip or other framework. Still, the typical components you will use are often a bit too small for all but the tiniest of fingers. That's where pliers and tweezers come into play. They are an extension of your own hands and fingers, increasing your precision and allowing you to perform delicate tasks with tiny parts.

There are several types of pliers and tweezers that you may use on a daily basis in your lab. See Figure 2-4.



Figure 2-4. Pliers and tweezers aid in working with small parts. On the left is a pair of needle-nosed pliers with cushioned grips and leaf springs. In the center is a pair of slip-joint pliers that can be adjusted to accommodate two different ranges of gripping action. On the right is a pair of needle-sharp tweezers, which can be used to pick up and place even the tiniest of electronic components—if your hand is steady enough!

Screwdrivers, Nut Drivers, Wrenches, and Ratchets

A lot of electrical connections can be made using only a screwdriver. Figure 2-5 shows an electrical connection using a *barrier strip*. A specialized connector is crimped onto the end of the wire and held in place with a screw. A variety of crimp-on connectors are available and should be installed using the appropriate tool, as indicated by the connector's manufacturer. Just smashing the connector onto the wire with some pliers is not recommended.

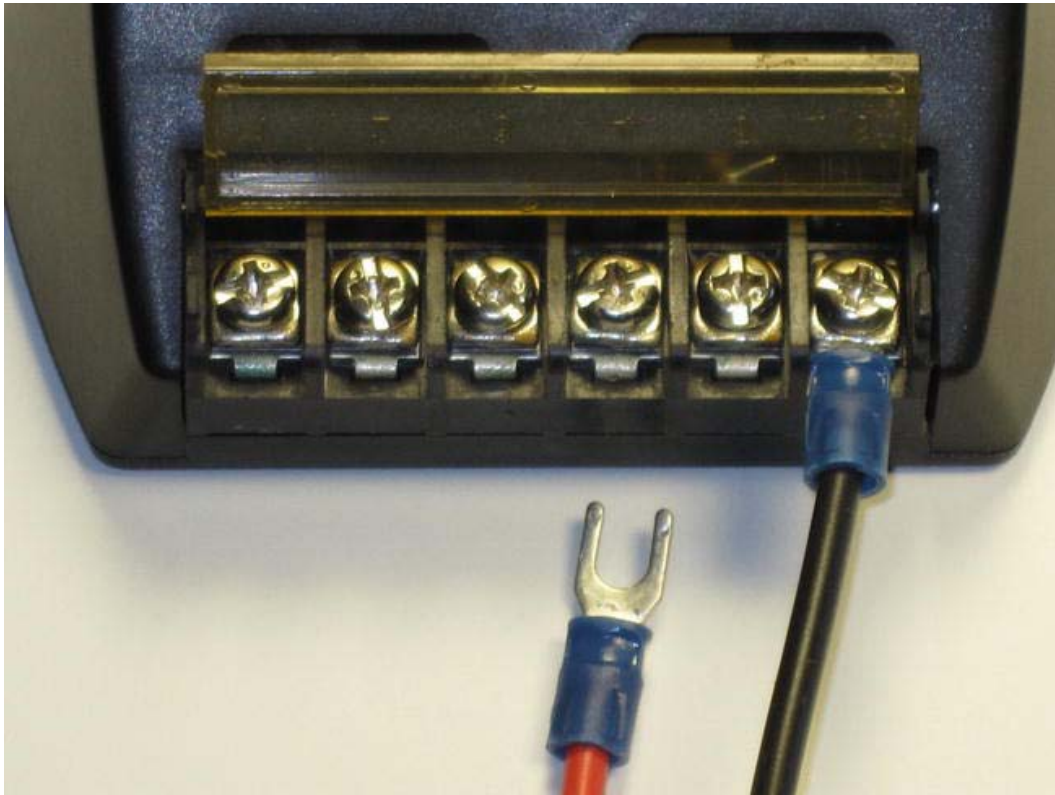

Figure 2-5. A barrier strip on a low-cost solar-charge controller. No soldering required! The specialized connector is held in place with a screw. The connector is affixed to the end of the wire by deformation using a specially designed crimping tool. You can see the indentations in the insulating collar around the connector.

Another type of connector that is tightened with a screw is called a *terminal block*. Unlike a barrier strip, no specialized connector is required on the wire. You can simply insert a stripped wire into the terminal block and tighten the connector using a screwdriver. Try to strip the wire only enough to allow the bare conductor to enter the terminal block, without leaving any noninsulated wire exposed that could accidentally short out against another wire. See Figure 2-6.



Figure 2-6. A terminal block uses a screw for tightening the connection with a bare wire.

Besides being useful for making electrical connections using barrier strips and terminal blocks, screwdrivers are also quite handy in their original function, which is to tighten and loosen mechanical fastening devices such as screws and bolts. See Figure 2-7.



Figure 2-7. A variety of screwdrivers. The four on the left are standard, or straight-bladed, screwdrivers. The three on the right are Phillips-style screwdrivers. Other specialty bits are also available.

You should only use screwdrivers to drive screws and bolts. Don't try to use them as levers, pry bars, chisels, punches, or other tools. When you need a chisel, use a chisel. Keep your screwdrivers clean and dry. Put them back where they belong when you're done with them. You get to decide where they belong.

Screws, Bolts, and Nuts

There are a *very* large number of different kinds of screws and bolts. Some screws, such as wood screws, are made to be driven directly into wood and create their own threads in the material as they are installed. Other screws, largely referred to as machine screws, mate with a premachined or tapped hole, or a machine nut.

Nuts are often shaped with four or six sides that allow them to be held in place while the screw is turned. Alternately, the nuts themselves are turned while the screw is held in place. Some screws and bolts have a similarly shaped head that allows them to be turned with a wrench or nut driver instead of a traditional screwdriver.

Please resist the urge to overtighten screws and bolts. The mechanical advantage gained by the inclined plane of the screw thread multiplies the force used to turn the screw into a terrific amount of pressure on the screw itself. You can easily damage either the screw or the threads in the material to be fastened by overtightening a screw.

More Specialized Hand Tools

A good set of wire tools, pliers, and screwdrivers will go a long way when working with electronics. However, sometimes you need a more specialized tool for more specialized work.

Here are some of the more common tools that are a little more focused on a particular task than they are for general-purpose usage.

Wire Crimpers

As mentioned previously in this chapter, you can make solid electrical and mechanical connections using barrier strips and specially terminated wires. The optimized connectors used for this purpose require optimized tools for best performance.

Figure 2-8 depicts some examples of specialized crimp tools for electrical connections.



Figure 2-8. Some common crimping tools for affixing electrical connectors to wire

Referring again to Figure 2-8, the crimpers on the left are for crimping tiny pins to the ends of tiny wires that are then inserted into plastic connector bodies. The center crimp tool is for crimping modular jacks onto telephone cables. It also includes a wire-cutter blade (bottom) and a pair of controlled-depth stripper blades for removing only the outside layer of insulation from silver-satin flat telephone cord, without disturbing the individually insulated wires contained within. The crimp tool on the right features a ratcheting action that increases the crimping force applied to the connectors. This is the tool used to crimp the connectors show previously in Figure 2-5.

Computers

You might not think about computers as being “power tools” in your toolbox. As the size of computers, laptops, tablets, and smart phones decreases, and their computing power, networking ability, and storage capacities increase, they become much better candidates for use in the lab.

Traditional “desktop” personal computers (PCs), laptops, netbooks, and tablets can perform multiple roles in your laboratory setting. If you are lucky enough to have Internet access on your computer, it can become a conduit for all types of useful electronics information, in addition to its more accepted role as a source of funny cat videos. See Figure 2-9.

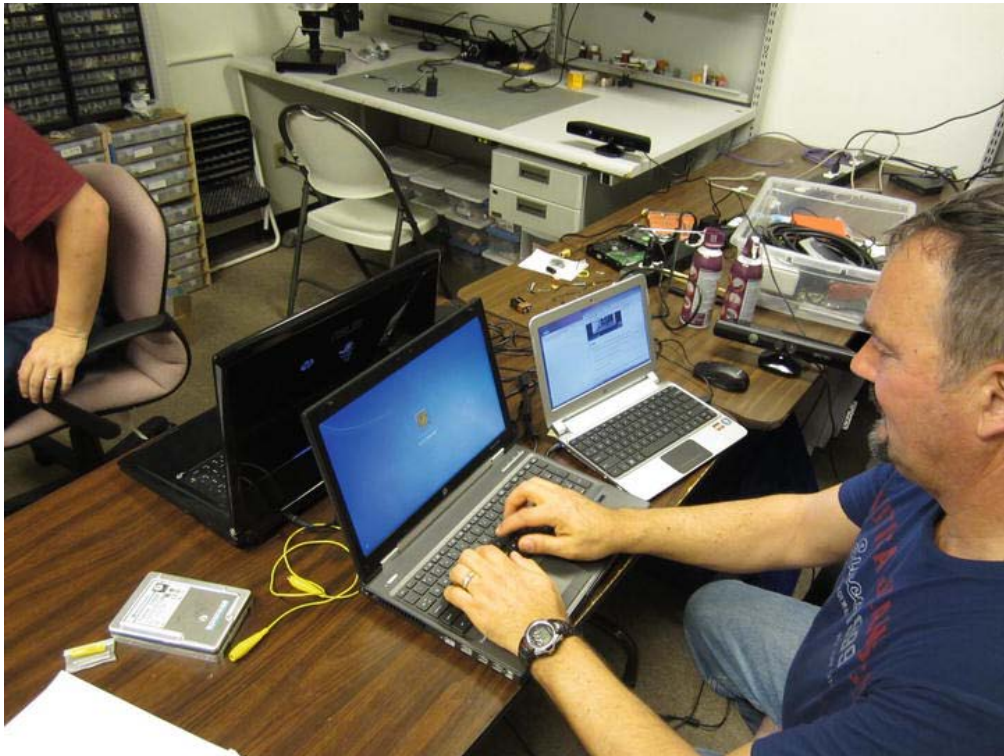

Figure 2-9. Computers being used in the lab. Paul Bouchier of DPRG uses two laptops at once when testing new robot software with the Microsoft Kinect (just to the right of his mouse).

Here are just a few of the many possible areas of practical knowledge, learning opportunities, and bits of interesting information that you can access using your computer:

Data sheets: Almost all electronics manufacturers provide online access to a library of technical data sheets and application notes for their products. These should be your first choice for information about how and when to use their products. These sources also contain important product *errata*, which contains corrections and updates for products that have been made since their first publication.

Online tutorials: The Web abounds with detailed and thought-provoking tutorials and background information on every topic imaginable, including, not surprisingly, mountains of information on computers and electronics.

User forums: People tend to cluster around others with similar interests. Once upon a time when people were geographically limited and unable to communicate or interact with folks around the world, this severely restricted a lot of the more specialized areas of knowledge. Today, you can find user groups centered on every conceivable human endeavor (and some inconceivable ones, too) that are filled with helpful, knowledgeable members that are more than happy to answer questions and share experiences with you. Do try to be courteous, respectful, and fair when asking for help with your projects, and always try to repay in kind by helping those with similar questions that you've had to master.

Sharing/collaboration web sites: As the cost and complexity of publishing your work on the Internet becomes more manageable, it becomes faster and easier to let others know about your progress, as well as your problems. You can easily set up your own web page for little or no cash, or join many of the available user groups that allow their members to post, browse, and otherwise benefit from the works of other similarly minded individuals.

Design tools: You can find many free or reasonably priced electronic design and simulation tools online. Some manufacturers also provide free tools specifically for optimizing designs for their products.

Online suppliers: Where you once had to walk (or drive) down to the store and see what was available in your area as far as electronic components and tools went, now you can browse through the catalogs of suppliers from all over the world, from the comfort of your own lab. Not only does this provide a much larger field from which to choose, it also levels the playing field, so to speak, forcing worldwide competition for your hard-earned cash. Bonus: Some manufacturers offer a limited number of free samples. Yip!

This list only scratches the surface of the kinds of information you can access using a computer. You can also use a computer as part of your electronic projects, and several examples of doing this are included later in the book.

Tools for Soldering

You don't have to learn how to solder to work with electronics, but it helps. It really does. It opens a whole new world of possible projects, repairs, and custom modifications to existing equipment. Just remember, as always, to keep your work area clean and safe. See Figure 2-10.



Figure 2-10. A Weller controlled-temperature soldering station. What a mess!

Like any worthwhile skill, soldering is best mastered with lots and lots of practice. The best way to learn this useful skill is to have someone show you how it's done. It's difficult, but not impossible, to learn proper soldering techniques from a book. That being said, have a look at Figure 2-11.

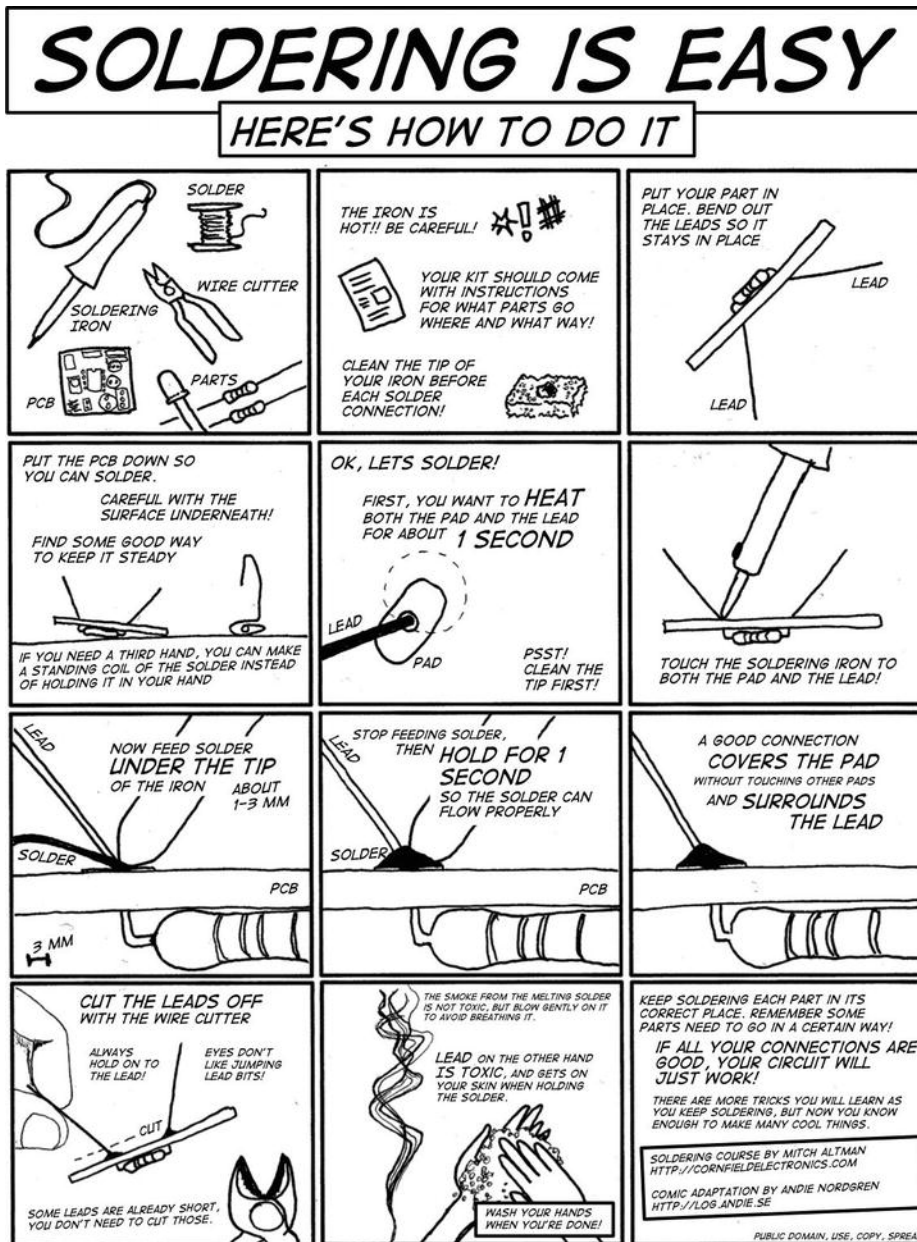

Figure 2-11. Instructions for soldering. This delightful illustration by Andie Nordgren captures the basics of soldering as taught by soldering guru Mitch Altman (<http://log.andie.se/post/397677855/soldering-is-easy>).

To solder, you will need a soldering iron. You will also need some solder and probably some wire cutters. That's just the tip of the iceberg, however. Like any good tool, your soldering station will soon accumulate many *accessories* to enhance your soldering prowess.

To begin your soldering adventure, you will need a *small* soldering iron, some solder, and a damp sponge. The big, pistol-grip style of soldering irons are for much larger projects, such as plumbing. Ideally you want something in the 15W to 50W range. See Figure 2-12.



Figure 2-12. The pencil-grip style of soldering irons is better suited for working on small electronics projects.

The soldering iron in Figure 2-12 has a replaceable, conical tip. These tips are generally interchangeable for a particular model of soldering iron, but unfortunately not interchangeable between different models or manufacturers. Different tip shapes are also available, depending on what types of things you're wanting to solder.

The tip is usually made of copper, which is an excellent conductor of heat. Since copper really likes to combine with other metals at high temperatures (which is exactly what happens when soldering), most tips are coated in a thin layer of steel to give them much longer useful lifetimes. Tips still wear out, however, and should be replaced.

In this particular soldering iron, the next part of the iron is the removable barrel that holds the tip in place. This barrel is where the heating element is housed, so remember that it is just as hot as the tip! Try not to touch it. You will probably not want to make that mistake more than once.

The next section is the padded and insulated handle of the soldering iron, which is made of dense plastic foam. A quality soldering iron will be comfortable in your hand and won't produce excessive fatigue, even after hours of use. Lower-quality and lower-priced models will more rapidly take their toll on your hands.

Not shown in Figure 2-12 is the flexible power cord running back to the soldering iron's base. This cord supplies the electrical power that is converted to heat in the barrel, as well as some wires for a

temperature sensor. This allows the unit to control the temperature of the tip with great accuracy. Note the temperature dial in Figure 2-10. Lower-cost units omit the temperature control features and run at a constant power output.

It will take some amount of time for the soldering iron tip to reach a working temperature. Likewise, it will also take some time to cool off once you've turned off the soldering iron.

■ **Caution** Soldering irons are very hot in use and can cause painful burns. Always treat them with respect!

The solder you use will be determined by what kind of soldering you want to do. For most small, electronics-related soldering projects, a small-gauge tin-lead or lead-free solder can be used. Bear in mind that lead is a poisonous material that slowly accumulates in your system, should you come into contact with it, as your body has no good way of eliminating it. Wash your hands before and after soldering, just to be safe.

Soldering works best when everything being soldered is sparkingly clean. To help facilitate this cleanliness, chemical compounds known as soldering rosin are used. These compounds chemically clean the surfaces being soldered when exposed to high levels of heat. Some types of solder have rosin incorporated into them. You can also obtain rosin as a paste into which you can dip wires and component leads before soldering. Other types can be applied with a dispensing pen.

■ **Caution** Don't breathe the smoke emitted during the soldering process. If possible, use a fan or fume extractor to redirect the soldering fumes away from you.

Once your soldering iron is up to its proper operating temperature, clean the tip by wiping it gently on a damp sponge. Your tips will last longer if you resist the urge to clean them before replacing the soldering iron in its holder. Even though it seems counterintuitive to "put it up dirty," this will more than double the life of your soldering iron tips. Just be sure to clean the tip *before* you solder anything.

Power Tools

Everybody loves power tools, don't they? Sometimes it's enough to just *imagine* that you might need one to justify a trip to the store and subsequent purchase. While this may be human nature (or perhaps only the nature of one particular gender), it doesn't fully justify having one of each in the lab, *just in case*.

Drills and Drill Bits

You will, however, find a few particular tools to be especially useful in your lab. A good hand drill or drill press is one of those tools. There seems to be no end of things electronical that need a few more holes drilled into them. Electronic enclosures and control panels need good, clean holes drilled into them. If you make your own PCBs at home, you will find that they need *lots* of holes drilled into them.

Like any power tool, an electric drill needs and deserves your respect. You'd be surprised how much unintentional damage you can cause with such a simple device. Observe these simple safety rules when operating a power drill:

- Keep your work area clean and well illuminated.
- Remove any watches or jewelry you might be wearing.
- If you have long hair, keep it pulled back and tied out of the way.
- Always clamp down any work to be drilled on a drill press.
- Always remove drill bits from the drill chuck after use.
- Discard dull or rusted drill bits that cannot be resharpened.
- Always wear safety glasses when operating power tools.

Hand drills come in all shapes, sizes, and price ranges. Some are powered by hand cranks and some are electric. Rechargeable batteries make for very portable drills that you can carry almost anywhere. See Figure 2-13. The only drawback is their limited charge time. That's why you should always have at least one spare battery charged up and ready to go. Electric drills with wires attached don't have this problem. Just don't trip over the cord!



Figure 2-13. A rechargeable hand drill. This model is both variable speed and reversible, which are two very desirable features in a hand drill.

■ **Note** Power drills are also very handy when used with screwdriver bits. They can save you time and many blisters!

Drill bits likewise come in all sizes and shapes. You can buy sets with a variety of sizes, and these will usually come with a handy storage container that conveniently labels all the sizes for you. This only works, however, if you take the time to return the drill bits to their proper location once you've finished working with them.

A drill press has a large frame that facilitates drilling a precisely aligned hole, over and over again. You can make spindle-speed adjustments to drill presses (even small ones, such as the one pictured in Figure 2-14) either through an electronic speed control or by changing up the belts and pulleys that drive the spindle. There are even small frames for mounting handheld drills or rotary tools, such as the Dremel brand of tools. You can often, however, find actual, dedicated drill presses on sale for about the same price as the daintier Dremel tools.



Figure 2-14. A small tabletop drill press

■ **Caution** When working with drills and presses, always keep your work area clear. Always wear safety glasses when using power tools. Try to keep the chuck key handy. Don't leave drill bits mounted in the chuck when not in use. Many chuck keys have built-in springs that prevent them from remaining in the chuck. Those that don't risk being accidentally left in the chuck when the drill is turned on, which can either fling the chuck across the workshop or make a big mess of your favorite hands.

Laser Cutters and 3D Printers

While not everyone can afford some of the more expensive and esoteric tools that are available, some of these tools are getting more popular than others; excellent examples are laser cutters and 3D printers. See Figures 2-15 and 2-16.

Laser cutters and engravers use a powerful carbon-dioxide laser to cut through wood and non-chlorine-based plastics. The laser beam is focused onto the work surface using mirrors that are mounted in an XY gantry, allowing the cutting area to be controlled by a computer. Typical installations require venting to the outside because of the various aromas produced in the process, as well as a water-cooling system for the laser tube itself.

There are also some newer laser cutters being built by hobbyists from scratch.



Figure 2-15. A laser cutter. A powerful 40W carbon-dioxide laser is used to cut through wood and non-chlorine-based plastic, all under computer control. It can also be used as an engraver. This model is manufactured by Full Spectrum Engineering.

3D printers seem to be all the rage these days. We're all pretty accustomed to the idea of printing on paper with a computer, although it's still a pretty recent innovation, as far as the history of printing goes. The idea of printing a solid object, on the other hand, is considered to be something of a game-changer.

The simplest 3D printers use a plastic extrusion and a motorized gantry to operate as a kind of a robotic glue gun. A plastic filament is fed into a heated fixture that is moved around a print bed, leaving a trail of cooling, gooey plastic. Either the extruder or the print bed is moved using motors under computer control to build up a layer at a time of the desired object.

Higher-technology 3D printers use this and other techniques to produce tangible, solid objects. Some use layers of fine powder that is glued together with a binder dispensed from a print head, similar to an inkjet printer. As each layer is printed, the object is lowered and another layer is deposited. This can even be done with sugar, as in the case of the CandyFab 4000, designed by the clever folks at Evil Mad Scientist Laboratories (www.evilmadscientist.com/article.php/candyfab). A stream of heated air is used to fuse a layer of sugar into a single solid structure, and an object is built up of successive layers.

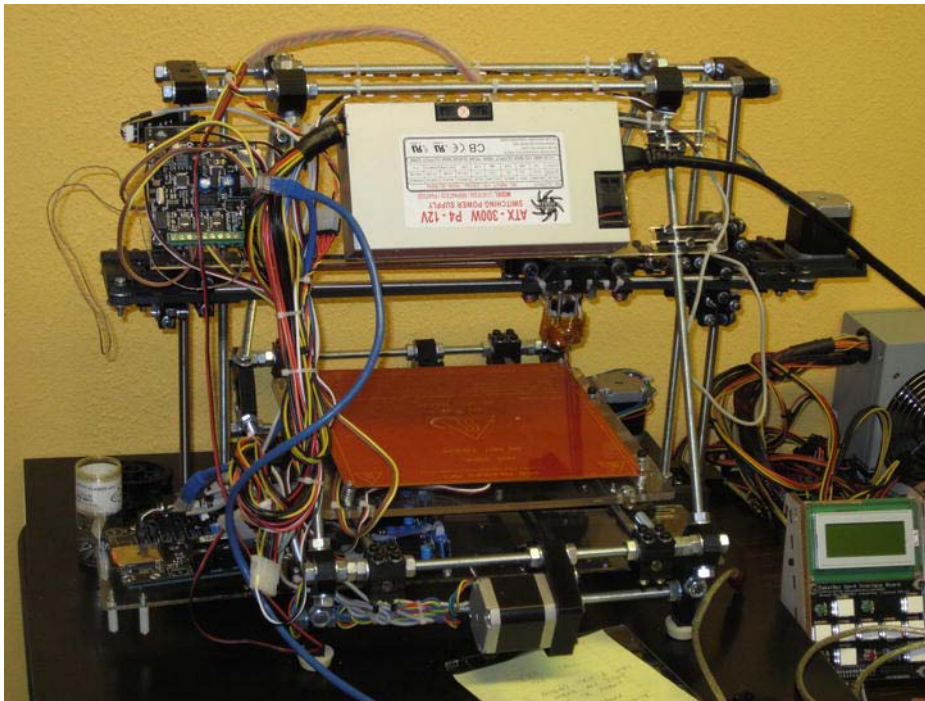

Figure 2-16. A 3D printer at Dallas Makerspace. This machine uses a heated extruder to build 3D objects out of plastic.

Basic Test and Measurement Equipment

When it is behaving itself, electricity is generally invisible. To “see” what it is doing, or not doing, you will need some specialized tools. These fall into the two general categories of *test* and *measurement* equipment.

The line between testing and measuring is sometimes blurry. One possible distinction might be that testing verifies proper operation within acceptable parameters, while measurement actually assigns

values to those parameters. An example of testing is, Does that flashlight work? The answer is yes or no, arrived at by the simple expedient of turning it on and observing the results. An example of measurement is, How much current does that flashlight draw? The answer might be 0.78A, and this would be determined using the appropriate measurement device, which in this case could be an ammeter.

Inspection Equipment

Sometimes, however, measuring things isn't hard at all, especially when the things being measured are actual, tangible items that you can hold in your hand. What you will need are some basic tools, primarily to be able to *see* what it is that you are measuring, and secondarily to take accurate measurements of them, at least in regard to their physical dimension. This comes in very handy when trying to identify components during repair or equipment upgrades, when the original technical documentation is not at hand.

Even the youngest and finest of eyeballs will need help with the teeny-tiny components that are available nowadays. You should try to find at least a small magnifying glass to examine fine details. If your budget allows, you might want to consider a microscope of modest power to look at your handiwork. Careful shopping will result in finding some older microscopes at bargain prices. Expect to pay a premium price for the shiny, new stuff. See Figure 2-17.



Figure 2-17. A very nice stereo microscope. The power cord running to the white ring (partially hidden) supplies power to a ring of white LEDs that help illuminate the field of view. The base is very heavy to help stabilize the microscope.

Even a humble magnifying lens can be very helpful in the lab, especially if it has a built-in light. See Figure 2-18.

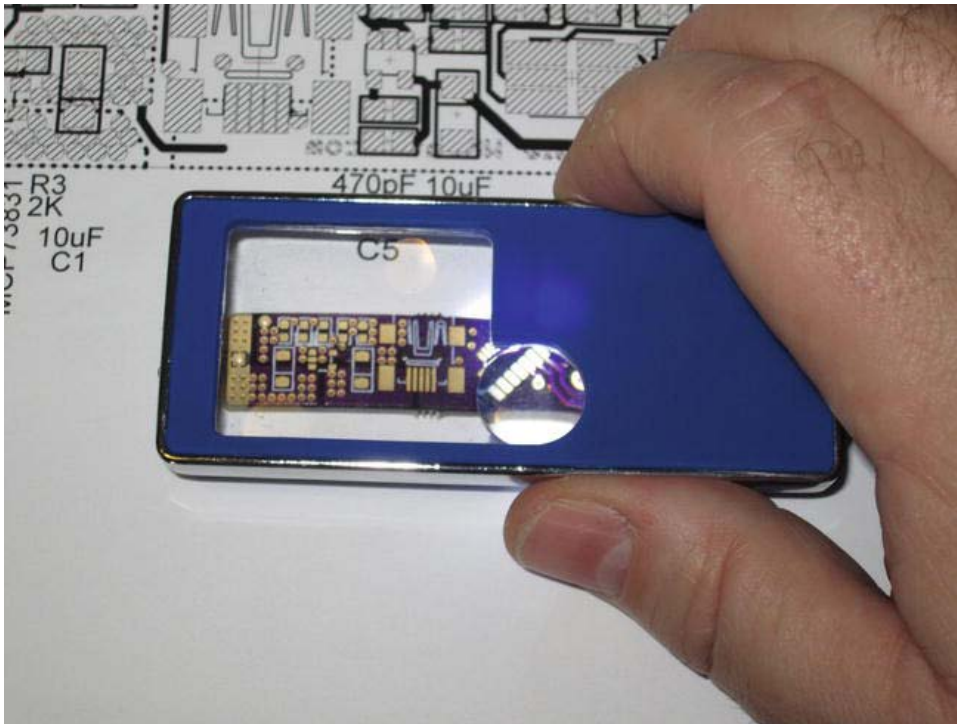

Figure 2-18. A small, handheld magnifier with a built-in LED light is very handy for examining small features and details, such as are found on many PCBs.

Physical Measurement Devices

Once you know what something looks like, at extreme close-ups, can you describe in absolute terms how big it is?

Take a look at Figure 2-19. Here we have, from the top to the bottom, a traditional tape measure, marked in both English and metric units (fractional inches and decimal centimeters), a digital caliper that can render measurements in either system at the touch of a button, and an architect's scale. While it may not be evident in the top-down view, the architect's scale is triangular in cross-section, resulting in not two but *six* different measurement options. This is mostly due to architects liking to draw things to scale, instead of full-sized.

The digital caliper is interesting in that it also provides a computer interface so that its readings can be pulled in by a computing device of some sort. These devices used to be quite expensive, but mass production has brought their prices down significantly.



Figure 2-19. From top to bottom, a tape measure, a set of digital calipers, and an architect's scale.

Simple Electronic Measurement Tools

Now that you've got the tools to examine what these things look like and how big or small they are, let's move on to the more mysterious art of measuring their electrical properties.

Voltmeters

Voltage is a measure of electromotive force, and the standard unit of measure is the *volt*, named after Alessandro Volta, an Italian physicist. Voltage is sometimes compared to the pressure of water flowing through a garden hose, while amperage is compared to the amount of water flowing through the hose at any given time. It's not particularly useful to push this water analogy too far, but it's helpful in the beginning.

Voltage can be accurately measured with, you guessed it, a voltmeter. See Figure 2-20.



Figure 2-20. A panel-mount analog voltmeter (left) and a digital version (right)

A voltmeter measures the voltage, or *potential difference*, in a circuit across two points. Sometimes one of the points is a fixed reference point, such as the electrical *ground* mentioned in many circuits. This is often just a convenience for the purpose of measuring things, as the ground in an electrical circuit may or may not be connected to the ground under your feet.

A voltmeter will have two terminals, labeled positive (+) and negative (-). Looking at the analog voltmeter in Figure 2-20 (the one on the left), we see a needle that can swing from 0 on the left to 30 on the right. The prominent capital *V* on the dial indicates that the unit of measure is the volt. This indicates that you can use this meter to directly read from 0 to 30 volts, just by placing its terminals across a voltage. The meter itself is electromechanical in design, and creates a magnetic field that works against a spring and a fixed magnet. This action causes the needle to move to a point generally corresponding to the labeled voltage on the dial. These needles are not especially accurate, but can be corrected using the screwdriver adjustment at the bottom of the meter.

An analog panel meter such as this one does not require a separate power supply for proper operation. It draws all the power it needs from the signal being measured. This makes it unsuitable for measuring low-power circuits, where the current draw from the meter would unduly influence the reading.

The panel meter on the right is a digital circuit that measures the voltage and displays it on the built-in liquid crystal display (LCD). It requires a separate power supply for normal operation.

Ammeters

An *ammeter* looks and operates just like a voltmeter, except that it measures electrical current flow instead of voltage. The flow of electrical current is measured in units called *amperes* (A). The basic mechanism is almost identical to a voltmeter. To convert a current flow into a voltage, an electrical device known as a *shunt* is used. The shunt is simply a fixed-value resistor that produces a voltage across its terminals in relation to the amount of current that is flowing through it and its inherent resistance to the flow of current.

This relationship between voltage, current, and resistance is elegantly expressed in *Ohm's Law*. If you know two of the measurements in a circuit, you can calculate the third, based on their fixed and proportional relationship to each other. You will find this law to be exceedingly helpful to you when designing, repairing, and upgrading electronics.

To avoid using fractions, which seem to terrify so many people for no good reason, you can use Ohm's Law thusly:

- Voltage (volts) = current (amps) × resistance (ohms)
- Current (amps) = voltage (volts) ÷ resistance (ohms)
- Resistance (ohms) = voltage (volts) ÷ current (amps)

That's all there is to it, if you're just working with volts, amps, and ohms. Things can get weird, however, when you start to work with alternating current (AC), which is the kind of electricity you find in wall outlets and audio circuits.

Ohmmeters

An excellent application of Ohm's Law is found in building a resistance meter, also called an ohmmeter, because it measures resistance. Resistance is measured in units called ohms, often abbreviated with the capital Greek letter omega (Ω).

There are two ways to do measure resistance. One is to pass a known voltage though the unknown resistance and measure the current that is flowing in the circuit. The other is to pass a fixed current through an unknown resistance and measure the voltage across it. This second method is the one most commonly used.

You're most likely going to use a multimeter to measure resistance, as this is one of the more common functions of these handy devices. Mutlimeters are covered in the very next section.

Advanced Test and Measurement Equipment

It would seem that for simple circuits, having just a voltmeter, an ammeter, and an ohmmeter would be all you need. For the most part, this is correct. However, have you considered what would happen if you applied 100V to the 30V meter shown in Figure 2-20? What if you simply reversed the polarity of the signal by accident? Something bad for the meter, that's for sure. It might not actually catch on fire *right away*, but it would certainly damage the delicate, spring-loaded mechanism, possibly rendering it useless as a reliable measuring instrument.

The same can be said for an unprotected ammeter or ohmmeter. Luckily, the nice people that make good test equipment stay up late at night, thinking of the stupid things we might do with their products, and protect them accordingly. Let's look at some meters that measure multiple electrical characteristics, which strangely enough are called *multimeters*.

Multimeters

Multimeters will almost always allow you to measure various ranges of DC (direct current) volts, AC volts, current, and resistance. More advanced meters also measure things like frequency and duty cycle or even temperature. Some meters will even directly measure capacitors, inductors, and transistors using specialized connectors.

As with most tools, you generally get what you pay for with multimeters. The meter on the left in Figure 2-21 was purchased for under \$3, including shipping from China. It arrived DOA (dead on arrival) and was not deemed important enough to return. It will make an interesting clock or fake lie detector someday. The unit on the right was purchased new for nearly \$400 and has provided over a decade of useful service. The unit in the center is modeled after the unit on the right, it would seem, but can be bought new for between \$10 and \$20. The unit in the photo was bought wholesale for \$4, because sometimes you get lucky. It's often handy to have a second meter in the lab—for example, when you need to measure the voltage *and* the current flowing in a circuit simultaneously, which you just can't do with a single meter.



Figure 2-21. Examples of some multimeters. The meter on the left features an analog display that is easy to read and accommodates several readout scales simultaneously. The remaining two meters have digital readouts and offer more accuracy. All the meters use a large rotary knob for selecting the proper function. The higher-cost unit on the right features auto-ranging, intelligently deciding what range to use. The right two units also have high-impact boots to help protect them in the event of a fall.

Your present budget will help determine what level of multimeter you might want to obtain. If you're wanting to sink less cash into a multimeter right now, consider looking for used equipment in good shape. As with any good tool, you can spend as much as you like on these. The sky really is the limit here.

Most all-in-one meters protect their inputs using fuses. You will have to disassemble your meter to replace these fuses, so think twice and measure once (to paraphrase the old carpenter's saying, "Measure twice and cut once").

■ **Tip** Be sure to set up your meter for the proper function and range *before* taking measurements.

Oscilloscopes

Once you've gone beyond measuring simple DC and AC voltages and move on to more complex signals and waveforms, you'll have to lay aside your trusty meter and fire up your favorite oscilloscope. This instrument is more complex than your traditional multimeter, and offers a different perspective on what's going on in your circuit.

While many modern oscilloscopes have many modes of operation, their basic function is to draw a picture of your signal on a small screen. In the olden days, this was done with a moving dot that was swept across a phosphorescent screen, leaving a residual, fading line of light. If this pattern was repeated over time, a visual representation of the signal could be seen on the screen. See Figure 2-22.

Modern oscilloscopes use a computer monitor or built-in screen display to draw the signal. This saves space, weight, and power requirements.

When purchasing an oscilloscope, the features you pay most for are the number of available channels and the bandwidth. The least expensive oscilloscopes will have a single channel. Having multiple channels allows you to "see" multiple signals simultaneously, which is often helpful in understanding what is going on in a circuit.

Bandwidth refers to the range of frequencies that can accurately be measured by the oscilloscope. Lower bandwidth scopes require much simpler electronics, and are thus cheaper to produce.



Figure 2-22. A Tektronix 475A oscilloscope. This piece of vintage test equipment is considered by some to be the best analog oscilloscope ever made. It also has a digital multimeter built in along the top edge.

The Golden Age

Once upon a time, not so long ago, a quality oscilloscope weighed 40 pounds and had a folding handle to make it, if not portable, at least *transportable*. It also had its own line of furniture to place it on, so that you could wheel it around the lab as you needed. Oh, and it also cost about three months' salary, and that's if you had a *good* job.

The good news? That same scope still works today. It can be repaired or calibrated to the exact same standards as when it was brand new, *plus* you can buy it on eBay for a few hundred dollars, sometimes less. That's because when these devices were designed back in the 1970s, they were made to be the best in the world, and cost was not a factor.

Modern Oscilloscopes

Today you can buy a quality oscilloscope for a few hundred to a few thousand dollars. These scopes not only display your signal on a large, colorful screen, but they can also analyze the signal and tell you all kinds of interesting things about it. For an example of such an oscilloscope, see Figure 2-23.

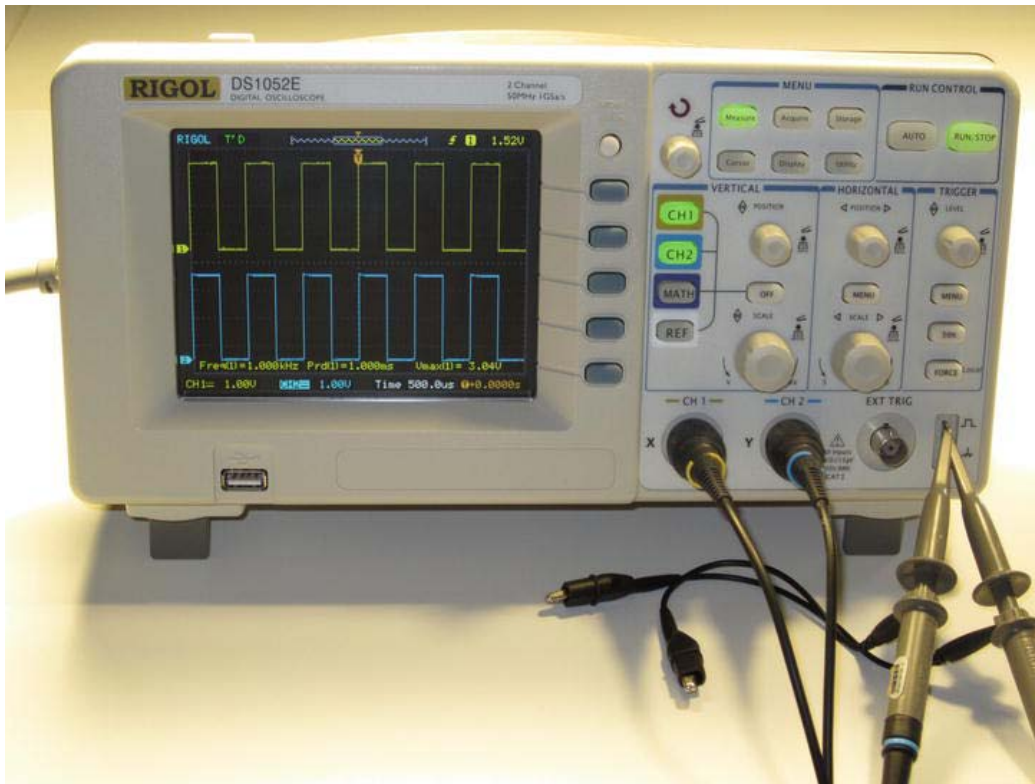

Figure 2-23. A modern digital storage oscilloscope. The RIGOL DS1052E is an affordable scope that will handle most troubleshooting and design challenges that you might encounter in your lab.

This new breed of digital storage oscilloscope (DSO) can even connect to your PC to be remotely operated and allow you to capture screen shots that can then be pasted into books about how to build your own electronics lab. It's true. See Figure 2-24.

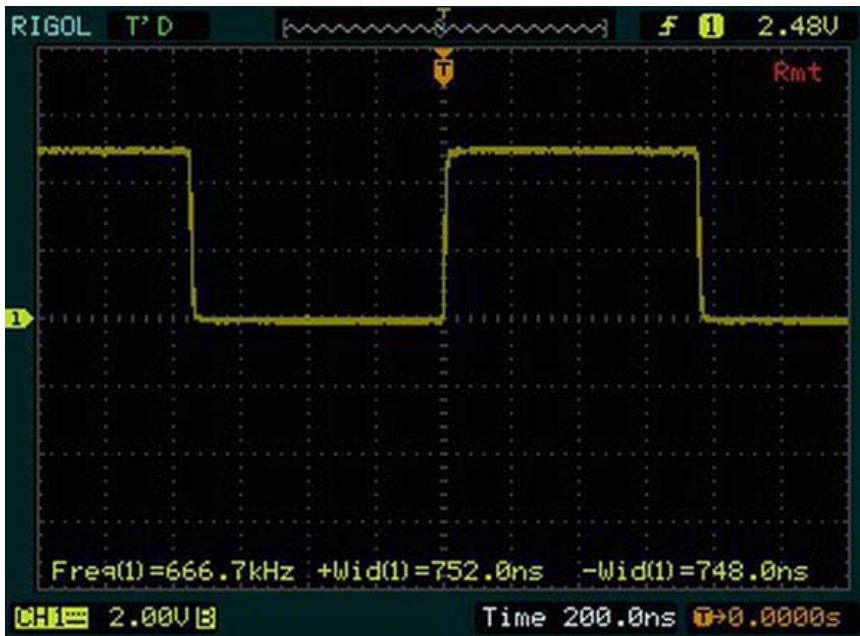

Figure 2-24. A screen capture made with the RIGOL DS1052E oscilloscope.

Tiny Oscilloscopes

The march of electronic miniaturization never stops, and so it is with oscilloscopes. If both your needs and your budget are modest enough, perhaps you can get by with something like the pocket-sized wonder shown in Figure 2-25.

While little scopes like this lack the accuracy and bandwidth of their larger relatives, they are definitely handy to have when you need to look at a signal. If you can keep your expectations in check when it comes to the user interface, you can get a lot of utility from such a small package.

Additionally, one of the benefits of a device such as this is that the hardware and internal software (yes, there's a little computer in there, somewhere) is all open source. This means that you have access to all the schematics and source code. And what does that mean? It means that if you have the skills and the right equipment, you can redesign the entire apparatus to fit your own requirements, assuming that you understand the basic limitations of the electronics. The sky is the limit. You are empowered.

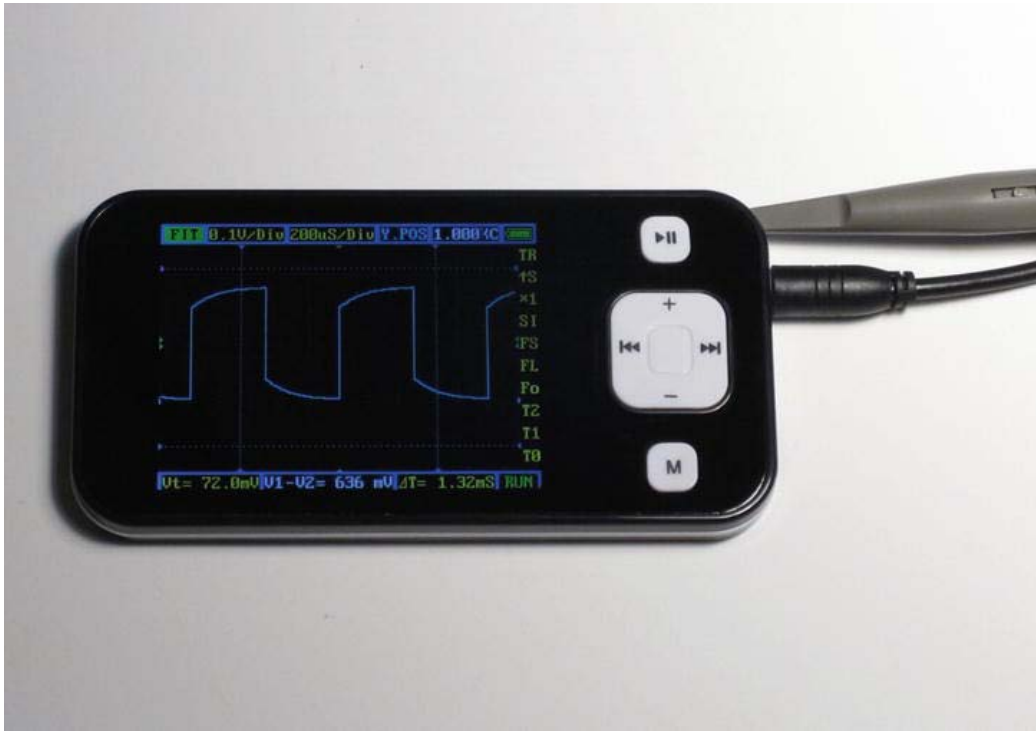

Figure 2-25. A handheld oscilloscope, which can also fit in your pocket. This is the DSO201, which has been discontinued by the manufacturer, but can still be snapped up for a song from various online distributors, as well as eBay. This unit was purchased new for \$60 and features a single channel with a bandwidth of 1 MHz.

Power Supplies

One of the most important pieces of test equipment in your lab is a reliable power supply. Building a good bench power supply is an excellent first or second electronics project (see Chapter 5 for more on adding power supply to your lab and Appendix A for more on building your own). This is because the basic design is very simple and easy to build, yet allows you to add any number of additional features later.

Once you get tired of throwing away spent 9V batteries and grow weary of waiting for the red light on the battery charger to go out, it's time to invest (either time or money or both) in a decent bench power supply.

It doesn't have to be fancy. In fact, the simpler the better at first. What you're aiming for primarily at this point is reliability. You want to know that when you turn on your 5V supply, it's putting out 5 volts, not 2 or 11, no matter what you do to it. If it's overloaded, it needs to deal with it and not be catching on fire. If it's underloaded, or not loaded at all, it still needs to maintain a nice, clean output.

Want a cheap or free power supply? Do you have any dead or discarded electrical gizmos that came with a charger? These make excellent starter supplies for the new lab. Do you have any extra USB

chargers? These are even better, because they supply up to 2.5W (and sometimes more) of *regulated* 5V. We'll use some of these in experiments in Chapter 3.

Organizing Your Tools

So now you have an idea about some of the tools you want (or already have) for your lab. Where are they all going to live? This is a big question, and deserves a big answer.

One way to look at this book is that the entire latter half is dedicated to answering this question. There are, obviously, many possible arrangements that will work for most people. But we're talking about *your* lab, with *your* tools, arranged and ordered to meet, specifically, *your* needs.

As you progress through Chapter 3 (the very next chapter in this book), you'll get a chance to play with both your tools and some interesting electronic components, all in the interest of getting you familiar with some basic concepts. These concepts and ideas are not new, but they may be new to you. The good news is that time invested today and in the very near future should pay off big dividends to you later in life. Who knows what you'll devise in that electronics lab of yours?

Summary

Starting with your brain and working outward, this chapter has covered some of the tools and devices you might use in your electronics lab. These include basic hand tools, computers, tools for soldering, some common power tools you might find handy, as well as some fancy-schmancy tools you might only find in a hackerspace, school, or electronics clubs, such as laser cutters and 3D printers.

You also learned about some of the basic test and measurement tools you'll be needing when working on electronic circuits in your lab. These include magnifying glasses, measuring tapes, and meters (oh my!), as well as oscilloscopes and power supplies.

Additionally, *lots* of advice on safety was presented. These topics were learned the hard way. Do try to learn from the mistakes of others, won't you?

Just a hint was given about how you might want to organize your tools within your lab. Take care of your tools and they will most certainly take care of you. The details about possible organizational scenarios is left for the second half of the book, where you will learn about setting up labs big and small, as befits your needs, budget, and interests.

Chapter 3 ties in much that you have learned here in Chapter 2 by introducing you to not only some of the basic electronics components and their uses and characteristics, but also how to use a good number of the tools described in this chapter. Hopefully this chapter has whetted your appetite and readied you to dive into some circuits and see what kind of mischief you can wreak on the world.

Components

You're going to need some components to play with, as well as the knowledge to use them effectively. This chapter will introduce you to some of the bits and pieces that make up modern electric and electronic circuits. It will also teach you a little bit about how to identify components from their appearance and markings, when available.

Once you've got an idea about what these parts do in a circuit, you'll learn a little more about how to measure their electrical properties and put them to use. You'll also be shown what *not* to do, in some select examples.

There are an enormous number of both manufacturers and vendors of electronic components these days. Trying to list even a few of them here in print doesn't really make much sense, as a good percentage of that information will be incorrect or obsolete as soon as the ink dries on the page.

Having a variety of basic components readily available is convenient, until your collection grows beyond your ability to house or organize it. This happens far too often, in reality. Most common electronic parts can be obtained within a day or two from local sources, unless you live in a really secluded part of the planet. Also, most of the more common parts will typically cost only a few pennies apiece, so there aren't a lot of reasons to stockpile random parts. Keep a few of each on hand for experimentation, but hold off on pointless hoarding . . . if you can.

Conductors and Interconnects

In any electrical or electronic circuit, there are just as many connections between components as there are components. These include wires, cables, connectors, plugs, sockets, and all those other pieces that help the little electrons zip around the circuit.

First, let's take a look at wires and interconnects in a very abstract way. We can think of wires as connections between other components, without having to get into a lot of detail about the wire itself. We just want a way to indicate that there is an electrical connection among all the bits, and using an electrical schematic diagram is an easy and effective way to do this.

Electrical Schematics

A *schematic* diagram is any kind of stylized drawing that represents a simplified view of something. Usually some sorts of symbols are used to represent the parts that make up the whole, as well as the connections or relationships that exist between them and possibly the outside world. You can have schematics for plumbing, hiking trails, or tribbles, as well as electrical and electronic circuits. Let's talk about electronic schematics for a little bit.

The electrical symbol for a wire is almost always just a plain, solid line. If there's something really special about the wire that needs to be used, it is usually indicated in a note somewhere on the schematic. This can be used to indicate what color the wire needs to be, what size is appropriate,

whether there are any special requirements for the insulation, and so forth. Most of the time it's just a plain, solid line. For an example of just how simple it can be to draw a wire in a schematic, see Figure 3-1.



Figure 3-1. A very simple electrical schematic diagram, showing how to get from point A to point B with a single wire. Drawing wires in schematics is easy!

If a wire starts in just one place and ends in just one place, everything stays nice and easy. If multiple wires need to converge on a single point, or one signal wire needs to split up to go to more than one destination, it gets just a little more complicated, but not too much. See Figure 3-2.

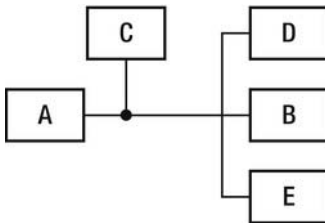

Figure 3-2. Wires that are connected to each other usually have a dot at their intersection. If there is no dot, there is no connection between overlapping wires.

In the figure, points A, B, and C are connected together. Points D and E are connected together, but are not connected to points A, B or C, even though the wires look like they are crossing. In a professional schematic, a careful draftsman would route the wire from point D to point E on the right side of the components to avoid any possible confusion.

Some folks like to draw a little bump, or bridge, when two unconnected wires cross in a schematic, just to make sure that everyone knows that the wires aren't connected. This gets to be a bit tedious once you've got more than two or three components in your schematic, and it can look a bit unsightly. Feel free, however, to draw your schematics however you see fit. Just remember that others might not share your particular drafting sensibilities.

Wire and Cables

Chapter 2 took a quick look at wire and how it is made to help you pick out the best wire-cutting and wire-stripping tools. Now it is time to consider wire as an electrical component within your circuits. Knowing what a wire can and cannot do will help you pick the right kind of wire to use. Yes, wire has limits! This is important both for building new circuits from scratch as well as repairing, replacing, or upgrading wiring in existing circuits.

Wire can be used for all sorts of artsy and craftsy purposes. Copper wire is the most common wire used in electronics. Sometimes the copper conductor is *tinned* with another conductive metal with a low melting point to make it easier to solder. When you cut this wire, you can see the copper on the inside.

Pure copper wire is getting very expensive these days. Unscrupulous people try to pass off copper alloy with inferior electrical properties as the real deal. A quick way to test is with a magnet. Copper is not attracted to magnets.

As mentioned in Chapter 2, wire comes in two major categories: solid core and stranded. Solid core wire is just a single piece of copper wire, while stranded wire is made up of many smaller strands of copper wire, usually twisted together. Stranded wire is generally more flexible than solid core wire.

Copper wire is measured using a gauge system. Different systems exist around the world. A common system used in the United States and Canada is the American Wire Gauge (AWG) standard. It uses a series of single numbers to denote the relative size of the wire, with larger numbers representing smaller-diameter wires. These numbers go all the way down to zero (0 gauge), but they don't stop there. Larger wires than 0 gauge are called 00 gauge, double-ought, or sometimes 2/0. There are also three- and four-digit versions, but after that, those giant wires are specified with their actual cross-sectional diameter.

Using Wire: The Very Short Version

Fatter wires carry more current with less heat being generated due to resistance. The wire's insulation is rated for a maximum voltage and temperature. If this temperature is exceeded, the insulation will soften, melt, or catch on fire. Avoid this by using the right sized wire for the job. Exceeding the maximum voltage can cause more problems if the current arcs through the insulation. This can cause a short circuit and may even cause a fire. It is also likely to give off noxious fumes. Choose wisely!

For low voltages (under 36V) and small current loads (under 1A), you can use whatever you want. It doesn't matter. Pick something pretty. A thing of beauty is a joy forever.

For higher-voltage applications, make sure the wire's insulation is rated *far in excess* of what you anticipate. The rating should be visibly printed on the insulation itself. See Figure 3-3.



Figure 3-3. The wire's insulation only works up to a point. That point is usually printed on the insulation itself, but you may need to put on your good reading glasses to see it. This wire states, "LL33911 CSA TEW 105°C 600V FTT 14AWG," which translates to the manufacturer's part number, Canadian Standards Association certified thermoplastic equipment wire, maximum temperature of 105°C, 600V insulation dielectric strength, 14 gauge.

For higher-current applications, you really need to use the highest-gauge wire that is necessary to carry the required current. Hot wires cause fires.

Using Wire: The Longer Version

If you will spend some time learning about the properties of wire, you will be able to make *much* better decisions regarding its use and application. Assuming that the overall shape of the cross section of the wire is round, the gauge of the wire determines how much resistance to the flow of electrical current the wire will exhibit over a given distance. This resistance, in turn, helps determine the amount of electrical current that the wire can safely carry.

When electric current meets resistance, the electrical power is converted into some other form of energy. Usually this energy is given off as heat, or thermal energy. It can also produce magnetic fields, sound, light, and radio waves.

A good example of this is demonstrated by the heater coils on an electric stovetop. When the stove's switch is turned on, current flows through the coil. Most of the current is converted directly into heat. Electric heaters are very efficient this way. A small amount of the electrical power is converted into light. You can see this as a red glow coming from the heater coil when it is hot. The coil also creates a magnetic field.

If you know the gauge of a wire, you can look up the wire's characteristic resistance. These numbers will be close but perhaps not exact, as there will always be small variations in wire diameter, conductor purity, and other factors. Generally, however, the numbers are pretty close.

Let's take another look at the AWG table (see Table 3-1), and look at a few simple examples to help understand what these wires can do for us. (A more complete listing is available at http://en.wikipedia.org/wiki/American_wire_gauge, from which this partial list was obtained.)

Table 3-1. *The AWG*

AWG	Diameter Area		mm ²	Copper Resistance	
	Inch	mm		Ω/km mΩ/m	Ω/1000 ft mΩ/ft
0000 (4/0)	0.46	11.684	107	0.1608	0.04901
000 (3/0)	0.4096	10.404	85.0	0.2028	0.06180
00 (2/0)	0.3648	9.266	67.4	0.2557	0.07793
0 (1/0)	0.3249	8.252	53.5	0.3224	0.09827
1	0.2893	7.348	42.4	0.4066	0.1239
2	0.2576	6.544	33.6	0.5127	0.1563
3	0.2294	5.827	26.7	0.6465	0.1970
4	0.2043	5.189	21.2	0.8152	0.2485
5	0.1819	4.621	16.8	1.028	0.3133
6	0.1616	4.115	13.3	1.296	0.3951
7	0.1443	3.665	10.5	1.634	0.4982

8 0.12	85	3.264	8.37 2.06	1	0.6282	
10 0.10	19	2.588	5.26 3.27	7	0.9989	
12 0.08	08	2.053	3.31 5.21	1	1.588	
14 0.06	41	1.628	2.08 8.28	6	2.525	
16 0.05	08	1.291	1.31 13.1	7	4.016	
18 0.04	03	1.024	0.823 20.9	5	6.385	
20 0.03	20	0.812	0.518 33.3	1	10.15	
22 0.02	53	0.644	0.326 52.9	6	16.14	
24 0.02	01	0.511	0.205 84.2	2	25.67	
26 0.01	59	0.405	0.129	133.9	40.81	
28	0.0126	0.32	1 0	08 10	212.9	64.90
30	0.0100	0.25	5 0	05 09	338.6	103.2

Conductivity

The first thing you need to know is that copper wire really, really wants to conduct electricity. It wants to conduct electricity more than it wants to *resist* the flow of electrical current. Even so, copper is not a perfect conductor, and it has a certain amount of inherent resistance. This resistance causes the energy carried by the electrical current to be sidetracked, or converted into heat and other forms of energy. The higher the resistance in the wire, the more heat will be produced.

Normally this heat is a very small thing and is easily dissipated into the surrounding air. You usually can't even tell by touching that a wire is a fraction of a degree warmer than its surroundings—but this is only true when the amount of energy is relatively small, like in our rewired flashlight example. When you start to push a *lot* of power through a wire, the heat buildup can outpace the cooling-off provided by the surrounding air, and the temperature of the wire increases.

Again, this is no big deal as long as that temperature stays within a comfortable range. But what happens when the temperature gets really high?

First, the insulation will get soft, melt, or even catch on fire. After the insulation, if any, has burned off, the wire will glow red hot and eventually melt. This is known as *catastrophic wire failure*, which can result in what electrical engineers refer to as an unauthorized thermal event, which we call a fire. Yikes!

But look around you. You're probably sitting right next to some wires right now, very few of which (hopefully) are on fire, even though they are carrying variously large loads. How do they keep from burning up? The answer is in the proper selection of the right *size* of wire for the job. Bigger wires have less resistance to the flow of electricity, so they are able to carry more power with less heat being produced.

Now, you don't want to have to wire up all of your electronic circuits using jumper cables from your car's trunk, as that gets to be cumbersome after a while. Let's look at some good guidelines for what size wire to use for your projects.

In Chapter 2 you learned about (or were reminded of) Ohm's Law, which illustrates the relationships between voltage, current, and resistance in any electrical circuit. In summary, $V = I \times R$, where V is volts, I is current in amps, and R is resistance in ohms. It's not just a good idea, it's the law!

So how much electricity will we lose going through a foot or so of 16-gauge wire? If we know that one foot of 16-gauge wire has a resistance of $4\text{m}\Omega$ (and we know this from looking it up in the chart), and we build a circuit that pushes 1A of current through this wire, we can figure out a couple of interesting things using Ohm's Law and a calculator.

Applying Ohm's Law

If you know two of the three variables used in Ohm's Law, you can calculate the third variable. Since we know R and I, we can calculate V. Since $V = I \times R$, we can substitute our values of 1A and $4\text{m}\Omega$ (0.004Ω) into the equation, and get 0.004V , or 4 millivolts.

That's not very many volts at all! In this case, that's a good thing. The voltage we just calculated is the *voltage drop* across the length of the wire. Those millivolts never make it from one end of the wire to the other—they're lost. Poor millivolts, they never had a chance.

OK, let's not let their heroic sacrifice be in vain. If we know volts, and we know amps, we can also calculate power, which is the rate at which energy is converted to work. The unit of measure for electrical power is *watts*, and is also the same as Joules per second (J/s), but that's another story. We usually use the capital letter *W* to abbreviate wattage, but we use the capital letter *P* to represent the *value* in equations.

Calculating power is simple if you know the volts and the amps. Just multiply them together: $P = V \times I$. Easy.

So in our example so far, we have 4mV , 1A, and $4\text{m}\Omega$. How much power is being dissipated (wasted) in this circuit? $P = 0.004\text{V} \times 1\text{A} = 0.004\text{W}$, or 4 milliwatts, which is just four-thousandths of a watt. That's just about enough power to light up a dim LED, and not much else. So you're not going to be starting any fires with these numbers. You most likely would not even be able to measure the rise in temperature that is occurring in the wire (oh yes, it's occurring, but it's very, very small).

Let's put 10A through a foot of 30-gauge wire. On second thought, let's not, and just do the math instead. The voltage drop will be $V = I \times R$, or $10\text{A} \times 0.1032\Omega = 1.032\text{V}$. The power dissipated would be $P = V \times I$, or $1.032\text{V} \times 10\text{A} = 10.32\text{W}$. That wire would be a crispy critter in no time. Ten watts doesn't sound like much when you're talking about a home stereo or a lightbulb or a hair dryer, but that skinny little wire has almost no surface area with which to dissipate the generated heat. This means that the temperature goes up, quickly. Bye-bye, little piece of wire.

As a side note, you just learned how most current-limiting fuses operate. The conductor within the fuse literally *fuses*, or evaporates, when the internally generated heat produced from an "overcurrent" situation rises beyond its melting point. Poof, the circuit is opened, and property and lives are saved.

■ **Warning** Never circumvent the protection afforded by a fuse.

Ideally what you want is the smallest wire that will carry the required amount of current with an acceptable rise in temperature. Remember that any rise in temperature is in addition to the *ambient* temperature. If you're sitting in a room that is "room temperature," which is assumed to be 25°C or 77°F (the same thing, if you want to check it), and you're expecting a 50°C rise in temperature due to waste heat, your wire is going to be 75°C , which is far too hot to touch. Remember that 100°C is the boiling point of (pure) water (at sea level). Hot!

One more thing that complicates the thermal calculations is that copper, as a conductor, has a *positive thermal coefficient*, meaning that the characteristic resistance of a piece of wire (which we can look up in the AWG table) goes *up* by a known amount as the temperature increases. You need to

consider this when you build circuits that are *supposed* to get hot, such as electric heaters. In most other cases, it's best to keep the heat to a minimum, as it represents wasted power, plain and simple.

Testing Your Wires

Can something as simple as a wire go bad? Yes, it most certainly can. How can you tell? Usually, it's because something doesn't work the way you think it should, or *worse*, it works sometimes and not others. A great deal of time, the problem is right at the end of the wire, where it is trying to make a connection with something else. However, it's possible for a wire to develop a problem right in the middle. This can be caused by a tiny nick in the insulation that lets in nasty elements such as rain and dirt, allowing the inner conductor to corrode. This type of problem takes time to make itself apparent, but it can certainly happen, especially in equipment that is exposed to the outside world for any length of time.

A quick way to test a wire is with a piece of test equipment called a *continuity tester*. This simple device usually is battery powered and has two probes. When you connect the probes together, the tester makes a noise, lights up a light, or maybe does both. Make sure your continuity tester's batteries are fresh and that the probes, if they are removable, are firmly seated in their sockets. Even test equipment needs testing from time to time.

■ **Note** A continuity tester is one of the easiest pieces of test equipment to cobble together yourself. See Appendix A for more information about building your own tools.

As mentioned previously, the problem is almost always at the very end of the wire. This is a good thing to know, so you can start looking in the most likely places first, saving valuable troubleshooting time.

A much better way to test a wire is with an ohmmeter. Using an ohmmeter, you can determine the *exact* amount of resistance in a wire, which under ideal circumstances should be very low. One ohm or less is typical for most normal-sized wires that you are likely to encounter. Super-long wires can have higher resistance, and that's where you can consult the handy AWG table to find out what the resistance is *supposed* to be.

When testing wires, especially wires with attached connectors, it's a good idea to wiggle the wire about vigorously, as this will reveal some intermittent connections for you.

Storing Your Wire

If you're buying new wire, it will probably come on a reel. It's often handy to keep common sizes and colors on your bench, if you have room. A paper towel-holder makes an excellent wire dispenser rack, although you can also spend more time or money buying a prebuilt one or designing and fabricating your own.

A custom red-and-black wire dispenser is shown in Figure 3-4. You might use a fixture like this if many pairs of identical-length wires are needed for a project. Not having to chase the wire spools all over the bench really saves a lot of time. This structure was built using a MicroRax miniature slotted aluminum extrusion (<http://www.microrax.com>), which is perhaps a bit of overkill, but was a lot of fun to plan and build. A coat hanger, artfully bent, would have also done the trick.

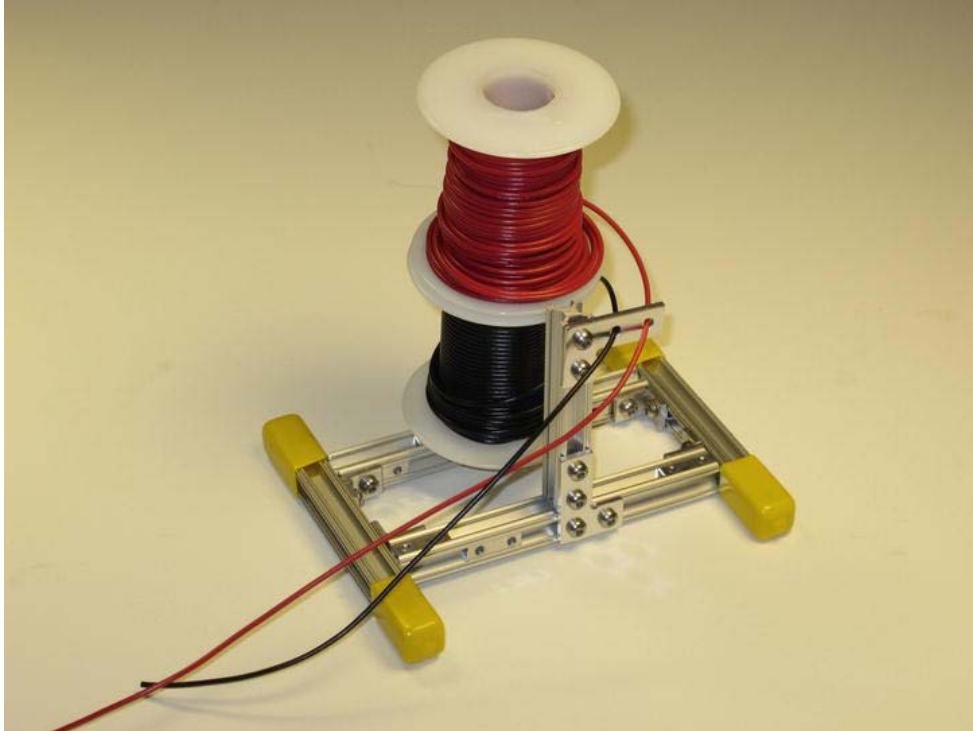

Figure 3-4. A custom wire-dispensing frame made from modular aluminum extrusion. This kind of fixture makes it easier to cut both a red and a black wire to almost exactly the same length, which happens a lot when you use red and black wire for positive and negative power connections, respectively.

Connectors

Connectors make life easier for the casual wiring enthusiast. The hardcore types solder everything together, but that is not always practical or even the right thing to do in every circumstance.

Keep in mind that every connector, just like every wire, has some sort of electrical limits. These limits must be respected.

Clip Leads

Also called *alligator clips* or *test leads*, you can buy ready-made wires or build your own from individual connectors. The flexible rubber or plastic boot extends the insulation of the wire. A spring-loaded jaw, often with serrated teeth, is used to clamp down on the wire, lead, or electrical terminal desired (see Figure 3-5).

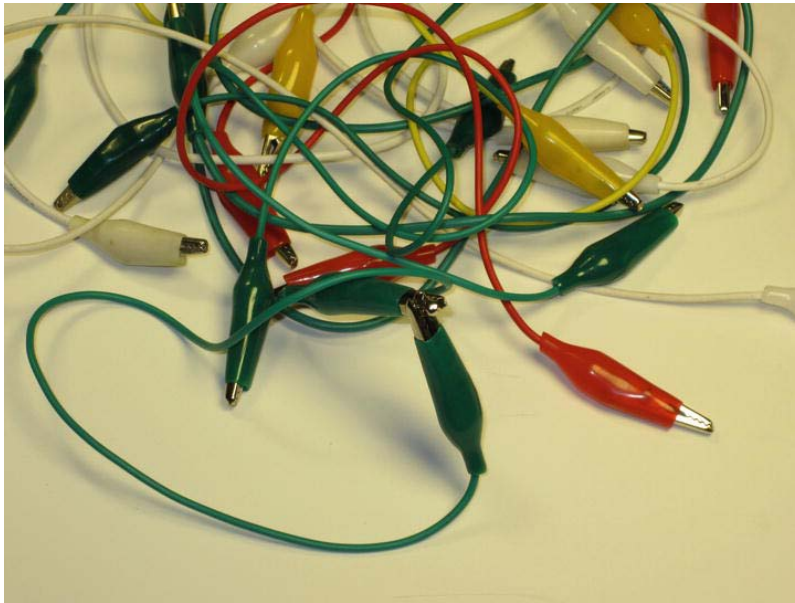

Figure 3-5. Clip leads come in all sizes, gauges, colors, and terminal types. They are handy for making quick electrical connections.

Clip leads are quite handy to have around your bench, if you've got the room for them. They tend to get tangled up, so some people hang them from a specially slotted rack, making them easier to pluck at a moment's notice.

Keep in mind that clip leads are generally for *temporary* electrical connections, such as when you're testing something or trying out a prototype circuit. They don't make very good long-term solutions to your electrical connection needs for a variety of reasons.

The first problem is that even when the spring-loaded jaws make a solid, low-impedance connection when first attached, this electrical connection will deteriorate over time as oxidation inevitably forms on the contacts.

Another problem is that many mass-produced clip leads are inexpertly smashed onto the ends of wires, without taking advantage of the alligator clips' built-in features, such as strain reliefs and soldering points. This leads to additional resistance in your circuit at both ends of the clip lead, where you would probably never think to look. The next time you buy some brand-new clip leads, hook them up to your ohmmeter and see just how conductive they really are. A good practice is to carefully remove the insulating boot and make a proper electrical connection yourself, so that you've got one less thing to worry about.

Solderless Breadboards

A very versatile prototyping platform is the solderless breadboard. Once upon a time, people would tack together simple electrical circuits using wires, small nails, and a hammer, utilizing a wooden plank or small board as the substrate. The kitchen breadboard was often just right in size and weight and would mysteriously disappear into the workshop. You can still cobble together simple circuits using this technique.

The solderless breadboard is a miracle of modern manufacturing techniques. A body made of precision-molded plastic has an array of small openings built in, and within each opening is a row of small spring clips that are just the right size to grasp and hold a small-gauge (22–26 AWG) wire. Adjacent points within the array are electrically connected together, which lets you easily connect small components into a circuit using your bare hands, with no soldering required. About all you would normally need would be some solid-core wire (preferably), some wire cutters, and some wire strippers. You can even buy precut jumper wires specifically made for use with solderless breadboards. They're terrifically handy! See Figure 3-6.

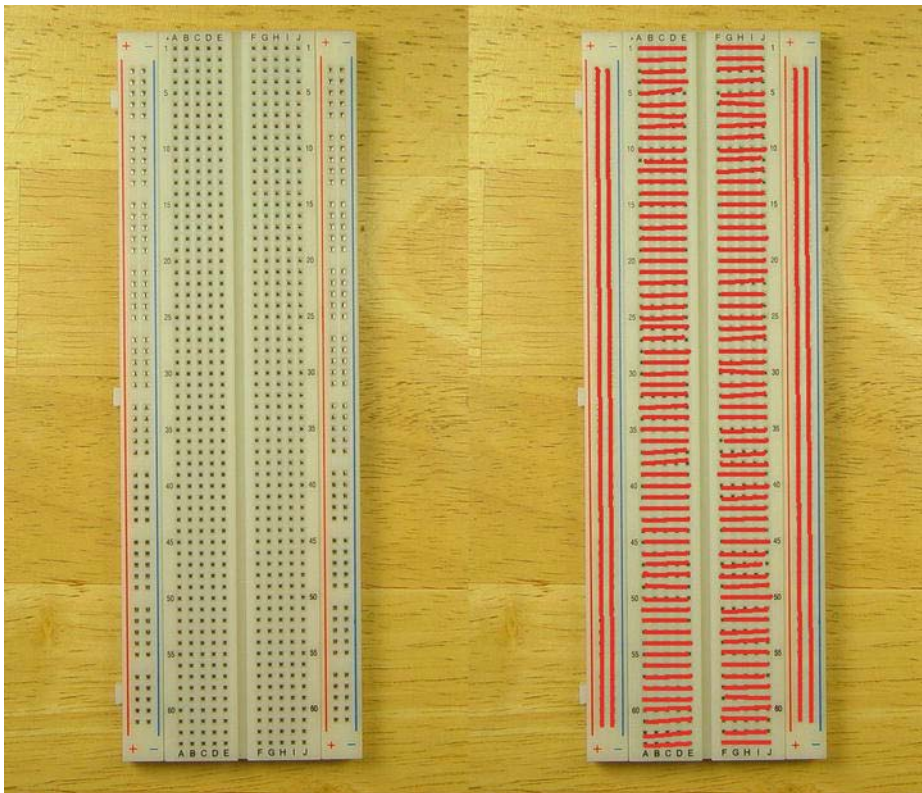

Figure 3-6. On the left is a solderless breadboard with 830 tie points. Each hole has a spring clip inside that can hold a small wire or component lead. On the right, the underlying electrical connections between the tie points are illustrated.

The spacing between adjacent tie points is exactly 0.1", which corresponds to many common “footprints” for electronic components. You can easily build simple circuits in just a few minutes. You can even build fairly complex circuits using integrated circuits and other components. Figure 3-7 shows a complete Arduino-compatible microcomputer that you can build with your bare hands and then program using your PC and the free Arduino software.

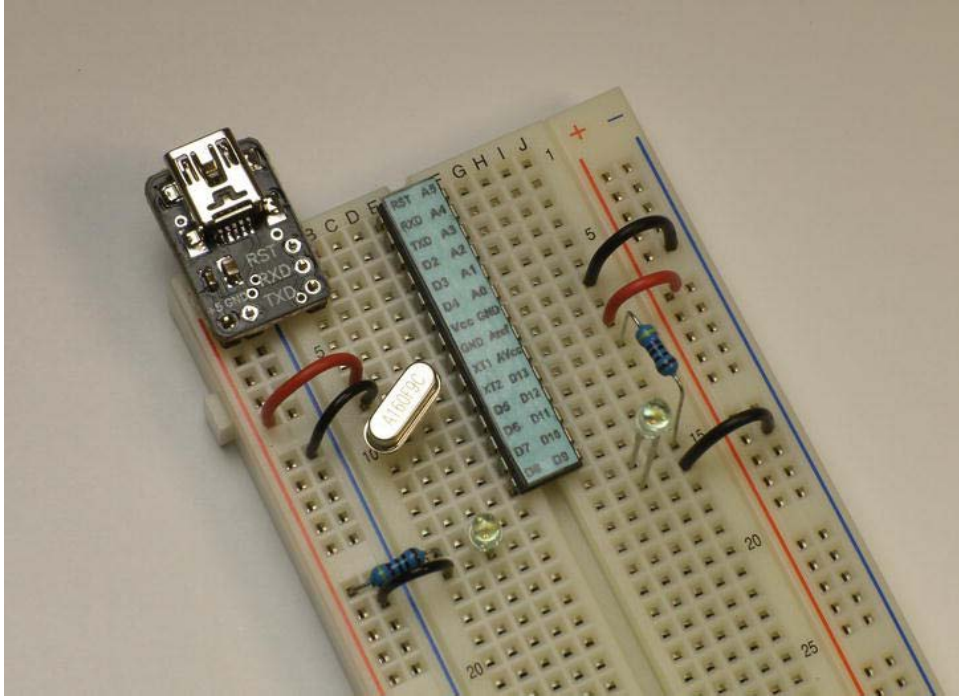

Figure 3-7. A breadboard Arduino, which is compatible with the popular Arduino Duemilanove microcontroller, can be built using just a handful of components on a solderless breadboard, leaving plenty of room for more experimentation. The black, rectangular component in the upper-left corner is a miniature USB adapter that supplies power, and provides communication and control signals for the microcontroller.

You'll find that projects tend to expand to fill the available area (and budget). See Figure 3-8.

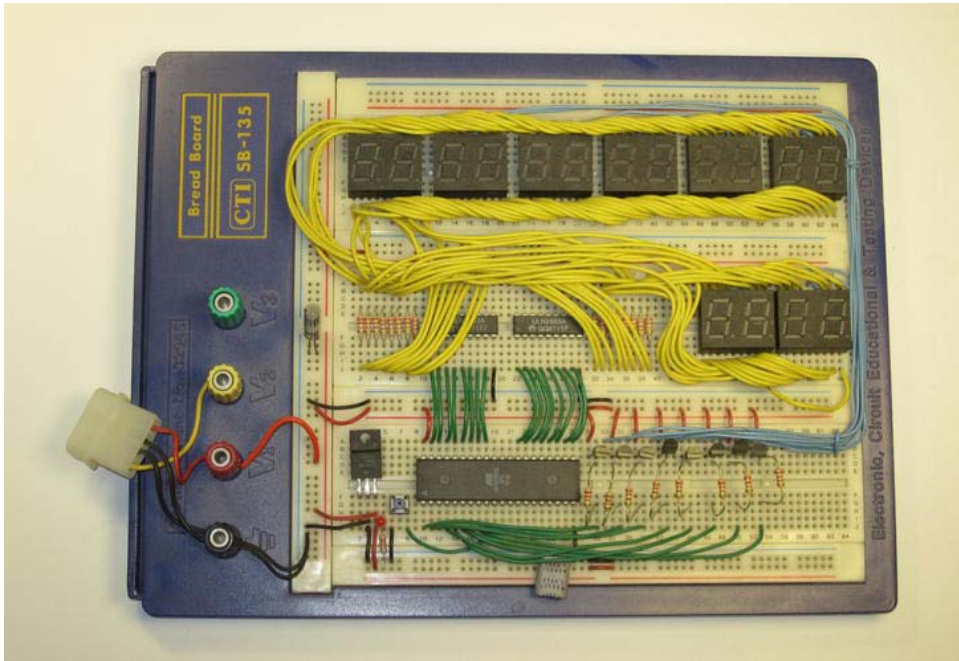

Figure 3-8. A prototype LED display with computer control, built on a solderless breadboard. That's a lot of wires!

Passive Components

Most electronic components fall into one of two different categories: *passive* and *active*. There are a few different ideas floating around as to what, exactly, is the difference between passive and active components. For the purposes of this book, we will use the simple definition that an *active* component requires a power source to work properly, while a *passive* component does not.

Resistors

A good example of a passive component is a *resistor*. You've already learned a lot about resistance in an electronic circuit. Resistance is measured in ohms, and it converts electricity into heat. When you're working with wires, cables, and other conductors, resistance is usually a *bad thing*. You want the least amount of resistance possible. However, there are times when you both want and need resistance in a circuit.

One example of when you would want resistance in a circuit is when you want to light up an LED. Unlike an incandescent lightbulb, an LED has no built-in current-limiting ability. Without a fixed amount of external resistance added to the circuit, an LED would self-destruct in a very short time, because it would overheat from excessive current flowing through it. A resistor would limit the amount of current flowing and control the brightness of the LED.

The exception to this dire prediction is when the power source that is lighting up the LED has insufficient gumption to blow up anything, such as with a small coin-cell battery. Anything bigger than

that normally has no trouble convincing the LED to release its magic smoke, without which it can no longer function.

A typical resistor has a fixed resistance and a maximum power rating. The resistance is determined by the material from which the resistor is made. The value of a resistor, as you already know, is measured in ohms, and can range from just a fraction of an ohm (often expressed as milliohms) up to millions of ohms.

Through-Hole and Surface-Mount Resistors

Resistors come in all shapes and sizes. Generally speaking, the larger the surface area of the resistor, the more power it can safely dissipate. A typical resistor that you might work with on a solderless breadboard or on an older PCB is shown in Figure 3-9. These are called *through-hole* components because their extended leads are meant to be formed and threaded through holes that are drilled into PCBs. Also in Figure 3-9, for comparison, are some teeny-weensy *surface-mount* resistors. Surface-mount resistors have no leads and are meant to be soldered directly to pads laid out on the surface of the PCB.

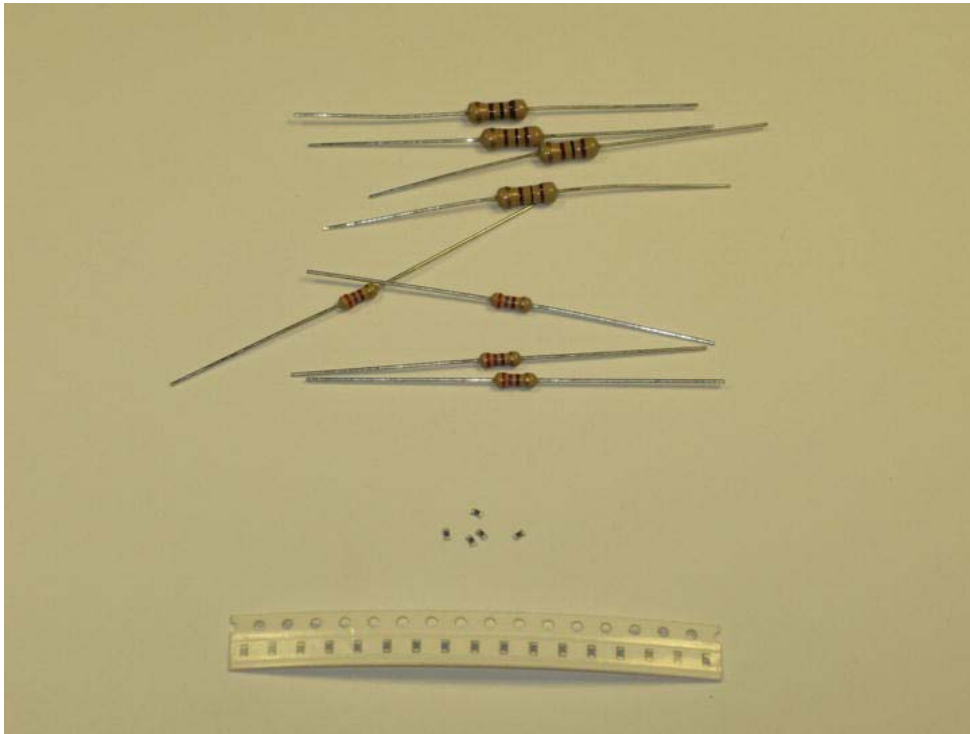

Figure 3-9. Some through-hole resistors (top) and surface mount resistors (bottom). The surface mount resistors are so small that they are shipped packaged in tape, which is usually wound on reels for automated placement in PCB assembly.

You can easily form the leads of through-hole resistors by hand or by using a *lead-bending jig*, a small tool with accurately spaced notches. Traditionally, these resistors have their leads formed so as to be threaded through holes in a PCB, and then soldered to the PCB. The extra lead length on the bottom of the PCB is then clipped off. See Figure 3-10.



Figure 3-10. Resistor leads are bent at right angles and inserted into holes in the PCB to be soldered.

Schematic Symbols and Reference Designators

The schematic symbol for a fixed-value resistor is a zigzag line. See Figure 3-11. Every component in your circuit should have a name, which is also called a *reference designator*. Typically, most reference designators will have a short letter abbreviation to describe what kind of part it is (*R* is for *resistor*) and a sequential number assigned as more parts are added to the schematic. R1 would be the first resistor, R2 would be the second resistor, and so on.

If there is only one resistor in your circuit, then you don't have to number them, do you? You can just call it *R*, or *Galactic Emperor R the Mighty*, or whatever strikes your fancy. Most people stick to simple numbers.

Your numbering scheme depends a lot on the complexity of your schematic. If you only have a few resistors in your circuit, you can start at one and go up as needed. If you have a complex circuit with many subcircuits, you might allocate R101, R102, R103, and so on, to the first subcircuit (e.g., a power supply), and then assigned R201, R202, and so on, to a different section, such as a display. It's entirely up to you. Use a system that helps *you* keep track of things.

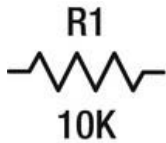

Figure 3-11. The schematic symbol for a fixed-value resistor is a zigzag. The reference designator for this resistor is R1 and its value is 10,000 ohms, or 10K Ω . A simple rectangle symbol is also used to represent resistors, although many components are available in this physical form factor. Use the symbol you like best.

Standard Resistor Values and Tolerances

Remember how wires have their own peculiar numbering scheme to describe their basic characteristics (i.e., the AWG, which uses *smaller* numbers to represent *larger* wires)? Well, resistors have their own peculiar numbering system as well to describe their electrical properties, or *value*. Even though the *value* of a resistor is measured in ohms and succinctly describes its characteristic resistance, not every possible value is readily available.

Some smart cookies at the Electronics Industries Alliance (EIA; see <http://www.eca.us.org/eia/site/index.html#>) have come up with some standard values that fill in most of the commonly used values for resistors and other components. Their scale is not linear but logarithmic, meaning that it takes larger steps as the values go up. This makes a little more sense once you understand how component value *tolerances* work.

You can buy, for example, a 1 Ω resistor and expect it to be pretty close to being 1 Ω at room temperature, but it's not going to be *exactly* 1 Ω . It's going to be pretty close. How close? Well, that mostly depends on how much money you're willing to spend on this single resistor. If the answer is "not that much," then "pretty close" is going to mean within 5 percent of the stated value. That means your 1 Ω resistor could actually measure as little as 0.95 Ω or as much as 1.05 Ω and still be "within tolerance." Five-percent resistors cost only a few cents even in small quantities.

Given that there's a little wiggle room for each resistor value, people who can tolerate their resistor values being off by as much as 5 percent don't need to be ordering 50 resistors of 0.99 Ω and another 50 of 1.01 Ω when they could just as easily (and certainly less expensively) order 100 resistors of 1 Ω with a 5 percent tolerance.

This overlap in the values of the resistors allows us to skip from 1.0 Ω to 1.1 Ω without having to keep track of all the little resistors in between. This is because a 1.1 Ω resistor could measure as little as 1.05 Ω or as much as 1.15 Ω and still be in tolerance.

With a standard resistor tolerance of 5 percent, we can use just 24 values to cover the range between 1 Ω and 10 Ω . The same multiples can then be used to cover the range between 10 Ω and 100 Ω , and so on. Aren't logarithms fun? See Table 3-2.

Table 3-2. The E24 Standard Values for 5 Percent Resistor Value Tolerances (Higher and Lower Decades Are Also Available)

1.0 10		100	1.0K	10K	100K	1.0M
1.1 11		110	1.1K	11K	110K	1.1M
1.2 12		120	1.2K	12K	120K	1.2M
1.3 13		130	1.3K	13K	130K	1.3M
1.5 15		150	1.5K	15K	150K	1.5M

1.6 16		160	1.6K	16K	160K	1.6M
1.8 18		180	1.8K	18K	180K	1.8M
2.0 20		200	2.0K	20K	200K	2.0M
2.2 22		220	2.2K	22K	220K	2.2M
2.4 24		240	2.4K	24K	240K	2.4M
2.7 27		270	2.7K	27K	270K	2.7M
3.0 30		300	3.0K	30K	300K	3.0M
3.3 33		330	3.3K	33K	330K	3.3M
3.6 36		360	3.6K	36K	360K	3.6M
3.9 39		390	3.9K	39K	390K	3.9M
4.3 43		430	4.3K	43K	430K	4.3M
4.7 47		470	4.7K	47K	470K	4.7M
5.1 51		510	5.1K	51K	510K	5.1M
5.6 56		560	5.6K	56K	560K	5.6M
6.2 62		620	6.2K	62K	620K	6.2M
6.8 68		680	6.8K	68K	680K	6.8M
7.5 75		750	7.5K	75K	750K	7.5M
8.2 82		820	8.2K	82K	820K	8.2M
9.1 91		910	9.1K	91K	910K	9.1M

Color Codes

Even the old-fashioned through-hole parts are a bit too small to legibly label with a numeric value and tolerance factor. A system of color codes was developed to designate resistor values, using colors to represent both single digits, a power-of-ten multiple, and the resistor's tolerance. These colors are painted on the resistors in bands. A little memorization and careful practice will have you reading resistor color codes in no time.

For 5 percent tolerance resistors, only four bands are needed to completely specify the resistor's value and tolerance. The first two bands represent the first two significant digits of the value. The next value is the multiplier. The final value is a special case to tell the resistor's tolerance.

The first two bands, as well as the multiplier value, use the color codes shown in Table 3-3 to represent the digits 0 through 9. (Unfortunately, these colors were chosen before the subtleties of colorblindness were widely understood.)

Table 3-3. *The Resistor Color Codes for the Significant Digits and Multiplier Digit of the Resistor's Value*

Digit	Color
0	Black
1	Brown
2	Red
3	Orange
4	Yellow
5	Green
6	Blue
7	Violet
8	Gray
9	White

The last band indicates the tolerance of the resistor using a different set of colors, as shown in Table 3-4. The most common are 5 percent (gold) and 1 percent (brown). There is supposed to be a slightly larger gap between the digits and the tolerance bands, but this is sometimes hard to see.

Table 3-4. Resistor Color Codes for the Final Color Band

Tolerance	Color
0.05%	Orange
0.25%	Blue
0.5%	Green
1%	Brown
2%	Red
5%	Gold
10%	Silver
20%	None

The multiplier digit can be thought of as either the number of 0s after the specified digits or as the exponent to which the number 10 is raised, as in scientific notation. Some examples make this easy to understand and remember.

A resistor marked with brown, black, red, and gold stripes has a resistance of $1\text{K}\Omega$ with a tolerance of 5 percent. An easy way to decipher this code is to do a simple substitution for the first two digits (brown is 1 and black is 0, so we have 10 so far). Next decipher the multiplier band and write down that many 0s after the first two digits. Red is 2, so write down two 0s. That gives us 1000 so far. The final band is gold, and that means a 5 percent tolerance; 1,000 ohms is usually abbreviated as $1.0\text{K}\Omega$ or simply $1\text{K}\Omega$.

■ **Note** *K* stands for *kilo*, the Greek prefix for 1,000. Likewise, *M* stands for *mega*, the prefix for 1 million.

This method works for most values from 10Ω to $10\text{M}\Omega$. A problem occurs, however, when we need to specify a value less than 10, as a negative multiplier value must be used to get an exponent of less than 0. For the value 1 and those less than 10Ω , a gold band is used for the multiplier. For values less than 1Ω , a silver band is used.

To save even more precious space on our schematics, another convention is to replace the decimal point with the multiplier. For example, $4.7\text{K}\Omega$ would be written as just $4\text{K}7$. $1.8\text{M}\Omega$ would become $1\text{M}8$ and 1.5Ω would be $1\text{E}5$. $10\text{K}\Omega$ would still be 10K using this method. If it is clearly understood that the unit of measure is the ohm, then even the Ω can be omitted.

Resistor Power Ratings

Any resistor has a maximum power-handling capability. This rating is usually expressed in watts or fractions of a watt. The larger through-hole resistors shown previously in Figure 3-9, for example, have a power rating of $1/2\text{W}$ (or 0.5W , if you prefer). This means that if you attempt to dissipate more than half a watt of power through the resistor, it is most likely going to quickly overheat and fail.

Thermal failure in a resistor starts with a thin curl of smoke, and then results in the discoloration of the resistor itself and sometimes actual flames. In any case, it gets dangerously hot, so do try to avoid this situation.

If you know the voltage across the resistor, as well as the current, you can easily calculate the power being dissipated using the simple formula $P = V \times I$. Remember that P is the power value in watts, V is the voltage in volts, and I is the current in amps. One volt at one amp is one watt, which is way more than enough to smoke our little resistors. Be careful! Any time you calculate the correct value for a resistor in ohms, be sure to also calculate the required power-handling capability.

Variable Resistors

So far we've only looked at *fixed*-value resistors. They usually exhibit the same resistance day in and day out. That's what we love about them. But what if you need to vary the resistance in a circuit? We have resistors for that, too! A good example is a volume control on an amplifier. Turn it to the left (down), and the volume goes down. Turn it to the right (up), and the volume goes up. How does that work?

One kind of variable resistor is called a *potentiometer*. Potentiometers are sometimes abbreviated as *pots*. Pots usually have three terminals instead of two. Two of the terminals connect to the fixed resistor that is inside the potentiometer. Instead of being all sealed up like the fixed resistors you've been studying, the internal, resistive conductor is exposed along a track or groove. The third terminal, which is often physically in the center, between the two other terminals, is called the *wiper*, and can be moved from one end of the fixed resistor to the other end, making electrical connection to the inner part of the fixed resistor as it goes. As the wiper moves along the length of the resistive element, it taps into the resistor at a different point, varying the resistance. This is how a potentiometer can be used as a variable resistor.

Figure 3-12 shows a typical three-terminal potentiometer with a round body. The shaft can be turned to adjust the resistance. There are many variations on this basic design.



Figure 3-12. A typical potentiometer, or variable resistor. Image by BG Micro (<http://bgmicro.com>).

The schematic symbol for a potentiometer looks suspiciously like a resistor with an extra terminal, which happens to be exactly what it is. The extra terminal is the wiper, shown as the upward-pointing arrow. See Figure 3-13.

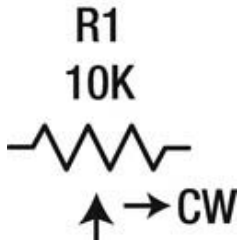

Figure 3-13. The schematic symbol for a potentiometer is a fixed resistor with a wiper terminal. The “CW” arrow indicates which way the wiper goes when the shaft is rotated clockwise.

Potentiometers generally come with two distinctive *response curves*, or *tapers*:

- A *linear* curve means that every equal step of rotation about the axis changes the resistance by the same amount. For example, if you were to center the shaft in the middle of its rotation, the resistance from the wiper contact to either of the end contacts would be nearly exactly half of the total resistance between the two end contacts. This is quite useful for when you need to adjust a voltage up or down in a relatively straight line. This is sometimes indicated by adding a capital *B* to the end of the resistance value (e.g., 10KΩ_B).
- In many audio circuits, however, it has been discovered that the human ear is anything *but* linear. A special response curve that more accurately describes this sensitivity is called an *audio* curve or taper. An *A* is used as a suffix to indicate that an audio taper is used for a potentiometer.

Note that linear and audio tapers are *not* interchangeable. If you find some random potentiometers in a parts bin, you can get a quick idea of what you’ve got by centering the shafts and seeing if the resistance is “symmetrical” or not, using an ohmmeter. Equal resistance to either end terminal indicates a linear taper, and anything else is mostly probably an audio taper.

Just like any other resistor, a potentiometer has a maximum power rating as well as a tolerance. These are usually either printed on the body of the potentiometer, if there is room, or hidden away in a product data sheet somewhere.

Specialty Resistors

There are many different kinds of resistors made for many special kinds of applications. High-power resistors are built out of sturdier materials that can take the thermal stress required to dissipate large amounts of heat. See Figure 13-14.



Figure 13-14. A power resistor can handle much more heat dissipation than the smaller through-hole or surface-mount varieties. They are often so big that they need special mounting hardware. Image by BG Micro (<http://bgmicro.com>).

Another popular option is the *multiturn* potentiometer. These potentiometers have an internal gear system that allows their shafts or wipers to be moved slowly across their internal resistive tracks by multiple turns of the control element. Increasing the number of turns allows the user much finer control of the resistance adjustment. It also takes the user longer to get from one point to another along the scale.

Capacitors

The basic definition of a *capacitor* is two conductors separated by an insulator. By itself, it doesn't sound like that would be a very interesting configuration at all. It turns out, however, that there's a lot more to it.

When a voltage is applied across a capacitor, no steady current flows through it. Remember, there is an *insulator* in the middle of that capacitor. Any insulator, just like the insulation on a piece of wire, *does not conduct electricity*.

What happens is that an *electric field* is created between the two conductors, or *plates*, as they are called when they are part of a capacitor. Now we get back to the fairies and dragons and molecules and so forth, way down deep at the heart of the problem. This electric field is a form of energy. Once it is built up by the difference in voltage, or *potential*, between the two conductors, it has nowhere to go, so there it stays . . . at least until something else in the circuit changes.

For this reason, capacitors are sometimes used as *reservoirs* of electrical energy in a circuit, holding a bit of spark here and there as needed. Just as it takes electrical energy to build up this electric field, a certain amount of electrical energy will be released when the field collapses. This will happen when the voltage between the two conductors drops.

Using capacitors as tiny electric batteries in a circuit is only one of many applications for this versatile part. While a capacitor will not conduct a *steady* flow of electric current between its terminals, it will often *appear* to conduct *alternating current* (as opposed to *direct current*), which is why you see them so often in audio circuits. As a charge builds up on one plate within the capacitor, it then attracts electrons from the other side, pulling them in from the other side. Even though they don't "jump the gap" of the central insulator, it looks like a tug-of-war is going on from both sides.

This behavior can also be used to send the higher-frequency components of a signal one way in a circuit and the lower-frequency components of a signal in another direction. This is one way that analog filters are built, and it has all kinds of useful and interesting applications.

Capacitors come in all shapes and sizes. They are made of many different materials, depending on what particular characteristics are needed. See Figure 3-15.

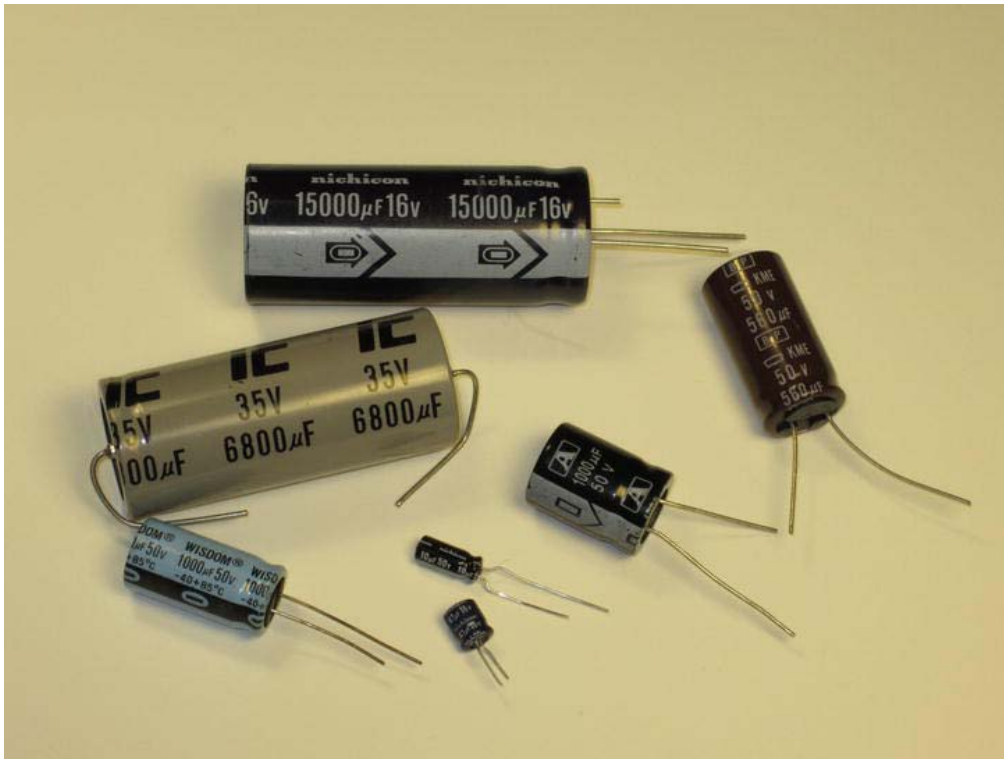

Figure 3-15. Some electrolytic capacitors of various sizes and capacities. Both much larger and much smaller capacitors exist and are very common in electronics.

Schematic Symbols

While there are a large number of special-purpose capacitors that are custom made for certain applications, a very large number of capacitors fall into two broad categories: polarized and nonpolarized. The schematic symbols for both types of capacitors display the fundamental construction of two conducting plates separated by an insulator. See Figure 3-16.

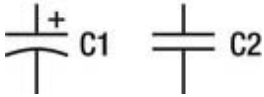

Figure 3-16. The schematic symbols for polarized capacitors (left) and nonpolarized capacitors (right)

C1 is a *polarized* capacitor, meaning one terminal is more positive than the other. In practice, this is indicated on the part itself in a variety of ways. One convention is that the *anode*, or more positive lead, is physically a little bit longer than the *cathode*, or negative lead. There is generally some sort of mark made on the capacitor body itself. Usually this is a stripe on the *negative* side of the capacitor.

What's really odd and potentially confusing is that one type of capacitor, specifically that made primarily of tantalum, has a stripe that indicates the *positive* lead of the polarized capacitor. Know your capacitors!

A polarized capacitor that is installed backward will experience terrible physical and thermal stresses and can sometimes explode, sending bits of itself all over the place.

C2 in Figure 3-16 illustrates a *nonpolarized* capacitor. It doesn't matter which way it is installed in a circuit. It is electrically symmetrical and works just as well in either orientation.

Inductors

An inductor is almost always made out of coils of wire. Sometimes inductors are quite large, as with transformers, while other times they are as small as a speck. An inductor would appear, electrically, as a simple short-circuit if it weren't configured to take advantage of certain principles of *electromagnetism*, or the tendency for the flow of electric current in a conductor to form a *magnetic field* around the conductor. The shape and orientation of the loops of wire that compose the inductor determine its electrical characteristics.

In many ways, an inductor is the opposite or complement of the capacitor. While a capacitor does not conduct direct current from one terminal to another, an inductor will happily do so, at least for a time. While a capacitor will resist a change in voltage across its terminal as it builds up its electric field, an inductor will resist a change in current flow across its terminal once it has established a magnetic field.

Because of their complementary natures, the two components can be used together to form a *tuned circuit*—one that resonates at a particular frequency, or allows the passage of only a certain range of frequencies, with the capacitor shuffling the high-frequency portions and blocking the low-frequency portions, while the inductor does the opposite, blocking the high-frequency components and passing the low-frequency ones. This is how many older radios and televisions worked before the advent of low-cost solid-state electronics.

Once an inductor has built up a magnetic field, any drop in the current flow across its terminals will result in the collapse of the field and the generation of a very-high-voltage spike. This is the basic electrical circuit that was used in automobile engines to create the high-voltage spark needed to ignite the fuel-and-air mixture in the combustion chamber.

Inductors can also be used to efficiently pass alternating current via a magnetic field from one inductor to another. This is how the primary windings of a power transformer *induce* a current in the neighboring secondary coil, which, depending on the ratio of windings and a few other factors, determines if the transformer *steps up* the voltage or *steps down* the voltage. It can even keep the voltage the same, for when electrical isolation is needed between two different systems.

Most electric motors employ some sort of inductor that alternately attracts and repels another electromagnet or permanent magnet. The most basic direct-current (DC) motors require a fairly complex mechanical arrangement to perform the necessary switch-swap to alternate the fields. This process is called *commutation*. In other types of electric motors, such as brushless motors and stepper motors, this commutation process is done electronically, externally to the motor itself, and requires more complex circuitry to control the speed and direction of the motors. See Figure 3-17.



Figure 3-17. Some simple DC motors. When direct current is applied to their terminals, they spin. The magic happens with an electrical and mechanical arrangement inside that performs the necessary commutation of the magnetic fields.

Switches

The most basic way to control the flow of electric current in a circuit is to literally *break* the circuit. This means that instead of forming a conductive loop from power source to components and back again, a gap is introduced somewhere in the loop.

This gap can come anywhere in the loop. It can be right next to the battery, for example, or somewhere off in the middle—as long as the circle is broken, no current will flow.

If you perform the lightbulb experiment in Chapter 1, you can see how this works. When everything is lined up properly and the final connection is made, the lightbulb lights up. When any of the connections are broken, the light goes out. It's really as simple as that.

Most of the electrical switches that you operate every day are really mechanical in nature. Their main function is to physically move two conductors either together or apart.

In the lightbulb experiment, you could use the wire as a switch, by physically touching either the battery terminal or the lightbulb (depending on how you were holding everything together). With a little practice, you could probably send Morse code, or at least a variation on "one if by land, two if by sea."

There are many kinds of switches for many kinds of switching tasks. The most basic are *momentary action* switches. These are usually push buttons, and only conduct electricity when pressed. Alternately, they can be built so that they conduct electricity all the time, *except* when pressed:

- The first option is called *normally open*. When a circuit is open, it is not conducting electricity. When you *close* the circuit, by completing the loop, electricity can flow. A normally open switch would be welcome in a doorbell circuit. When no one is pressing the button, no bells are ringing. It would be annoying the other way around.
- A *normally closed* switch acts like a solid piece of wire (being a conductor of electricity) until it is activated, when it ceases to provide a path for the electricity to follow. This type of switch can be used as a *kill switch* on a gasoline-powered engine, such as a lawn mower, for example. By interrupting the flow of electricity generated by the magneto and powering the spark plug, you interrupt the internal combustion cycle, which will eventually cause the engine to slow down and then stop.

This type of switch is called a *single-throw* switch. It's either on or it's off—conducting electricity or not conducting electricity.

■ **Note** For almost every possible configuration of switches, there is a corresponding *opposite* configuration that is almost as popular.

Another useful configuration for a switch is to switch from one circuit to another circuit, and not just on and off. This is referred to as a *double-throw* circuit. A switch like this normally has three terminals. A *common* terminal is usually, but not always, in the center. At any rate, the common terminal is electrically connected to the moving part of the switch that is going to make contact with one or the other two remaining contacts. The *normally closed* contact is the one that will be making contact with the common terminal when the switch is not activated, or at rest. The *normally open* contact is simply the other terminal. This assumes that the switch has some sort of bias or mechanical spring action that returns it to a certain orientation when no one is activating it.

Some double-throw switches can remain in either state indefinitely. A typical light switch used in indoor lighting is a good example. It's just as happy to stay on as off.

Switches can have more than one circuit built into them. These switches are called *double pole*, *triple pole*, and so forth. They're like two or more single-pole switches physically taped together, so that when one is switched, they all are switched. Usually these poles are electrically isolated from each other.

We'll play with switches again in Chapter 5, where you'll learn some interesting ways to wire them up.

Active Components

While it could truthfully be said that *all* electronic components require some electricity to do anything, the distinction made in this book between *passive* and *active* components is that *active* components need a little more power to be really interesting.

First we'll look at sources of this magical electricity, and then we'll move on to some of the fascinating and complex components that will happily use it all up for you.

Power Supplies

You're going to need some sort of power source for any electric or electronic circuit you run across. If it doesn't use electricity in some structured form, it's not really electronics, now is it?

Batteries

You can use regular batteries to power a lot of your circuits, but they eventually wear out, and then you have no real recourse other than to throw them away or recycle them, if possible. If you're going to be using batteries, at least get some good ones. Many of the bargain brands are terribly inferior in their manufacture and are only providing you with a false economy. Spend a little more and get higher-quality parts, and you will be rewarded with longer life and more reliable operation.

A great way to work with batteries is to use the appropriate battery connectors or battery holders. Sometimes you can remove these from obsolete electronic devices that have outlived their useful lifetime. Always observe the proper orientation and polarity of batteries. Even smaller batteries contain an annoying amount of power, especially when it all decides to come out at once, such as when you accidentally plug something in backward or short something out. This can result in damaged parts, burns, or even fires. Be careful with batteries.

Having a fuse holder wired inline with your battery-powered supply is an excellent and cheap way to prevent such "unauthorized thermal events." Keep several spare fuses on hand as well. Fuses cost little and save much.

Rechargeable batteries are becoming more common, and they keep coming down in price while improving in longevity and power capacity, and decreasing in size and weight. Any rechargeable battery technology beats any kind of primary, or nonrechargeable, battery in the long run.

■ **Caution** The same warnings about battery polarity and fuses apply to rechargeable batteries as well.

Since there's no easy way to "turn off" a battery, it would be a good idea to include a power switch in your supply, if possible. Just make sure that whatever switch you select can stand up to the maximum current you will want to be extracting from your power supply. You should also make your switch large and easy to see, so that you can find it quickly when you need it. An obvious power-on indicator is also a great plus for a homemade power supply. This can be as simple as a green LED (with appropriate current-limiting resistor—see below) or as complex as a voltage meter indicating how much juice is left.

Transformers

Another great power supply that you probably already own is a power adapter or transformer from another electronic appliance. You should use caution, of course, with anything that plugs into the wall for power, especially if you're planning on monkeying around with the other end of it.

Almost all commercially produced power adapters have a slew of certifications plastered on them. Somewhere in there should be the basic data concerning what type of power input it expects, what it is going to try to produce, and what the maximum limits are on the output. Make sure that whatever it is that you're going to plug into your wall is specifically designed to plug into *your* wall, as electrical power standards vary from one location to another.

Make sure that any repurposed power supply you use does not get overly warm when in use. This is an indication that it is presently or has been overloaded in the past. Such a device is a fire-starter waiting for its magic moment.

You need to know how much voltage is coming out of your power supply. Even if it is clearly printed on the device itself, if you have access to a voltmeter, you need to verify the output voltage before connecting it to anything. Many lower-cost power adapters are *unregulated* and will produce an output voltage that will vary wildly depending on the load applied to it. A *regulated* voltage output, on the other hand, will provide consistent voltage levels on the output, even with varying loads.

USB adapters and chargers are becoming quite common and can provide *regulated* +5V at up to 1/2A and sometimes more. These are great devices to use for small electronic experiments. They are generally small, lightweight, and reliable.

A dedicated bench power supply is a very handy piece of test and measurement gear to have available in your lab. A good supply will have a variable voltage and a readout to show you what's going on (or coming out). A step up and you get to set the maximum current that it will supply (to keep things from getting out of control too fast). Additional desirable features include multiple outputs and remote control from your PC.

No matter what kind of power supply you use, use it responsibly. Don't leave equipment powered up if you're not using it. Don't attempt to bypass safety measures that are in place for *your* protection.

Diodes

A diode is a semiconductor device that will conduct current in one direction only. That's the simple story. Of course, the reality is much more complex. A typical diode is composed of two pieces of a semiconductor material, usually silicon, but sometimes germanium or some other exotic substance. The diode action occurs in the *junction* between the two types of semiconductors, which have been specially manufactured to contain the exact right balance of impurities required. This is generally not the kind of thing you can build in your lab, unless you're Jeri Ellsworth.

These two bits of semiconductor, called the *N region* and the *P region* (for negative and positive, respectively), are sealed up in either a glass or plastic enclosure. A standard diode has two terminals—an *anode* and a *cathode*—which represent the positive and negative leads, again respectively. Conventional current (i.e., current flowing from the more positive voltage to the more negative voltage) can flow through the diode from the anode to the cathode, but not the other way around. It's magic! Well, technically it's semiconductor physics, but either answer will serve for our purposes.

Diodes come in all sizes. Generally speaking, the more power a diode is expected to handle, the larger it is going to be. *Small-signal* diodes are the same size or smaller than typical resistors. Power diodes, often called *rectifiers*, depending on their application, can be so large they have to be mounted with large bolts.

The two most important electrical characteristics for the happy care and feeding of diodes are their maximum reverse voltage and forward current capability. You don't want to exceed either one.

Since a diode is, at best, only ever going to have a cryptic part number written on it, you'll need to consult the manufacturer's data sheet to find out all the necessary information. Many semiconductor producers offer "commodity" parts that conform to standard part numbering schemes. That way, you know that a 2N4148 diode from one manufacturer is going to be pretty close to a 2N4148 diode from any other manufacturer, but you should always check to make sure.

Diodes typically have a *forward voltage* that must be exceeded before current will flow. This voltage is essentially lost and is dissipated as waste heat from the device. Silicon diodes will have an average forward voltage around 0.7V and up. Germanium diodes will have a smaller forward voltage, in the area of 0.3V. Schottky diodes use a metal-to-semiconductor interface region and achieve substantially lower voltage drops, making them much more suitable for higher-power applications.

LEDs

One special kind of diode is the popular *light-emitting diode*. You see these little guys everywhere these days. In fact, some folks go around with black tape, just trying to cover them all up so they can get their darkness back at night.

The reason that they are everywhere is that they are cheap, reliable, and easy to use. They don't take up much room, don't take up much power, and don't generate that much heat. The exceptions to these admirable qualities, of course, are in the newer generation of LED lighting products that emit tremendous amounts of light and produce tremendous amounts of heat. Every month it seems that a new record is set for efficiency. Let's hope that trend continues.

Being essentially diodes, LEDs have both an anode and a cathode. LEDs only conduct current in a single direction. You'll need to make sure you limit the amount of current flowing through your LEDs, because the LEDs themselves sure aren't going to do it.

LEDs designed to be indicator lights can be powered with as little as 1mA. High-efficiency LEDs can be used for illumination purposes and still only draw 20–30mA each. These very modest power requirements make LEDs a favorite for microcontroller projects, as these output power levels are easily handled by most popular chips.

The forward voltage drop across LEDs is typically much higher than for a rectifier or signal diode. In fact, the voltage goes up as the emitted color of the LED goes from the infrared and red end of the spectrum (1.2–2V) up to the blue and ultraviolet end of the spectrum (3–3.6V).

Transistors

A true modern miracle, the semiconductor transistor ushered in the age of solid-state electronics. More than a million individual transistors can be used to build modern computer processors, all on a single chip.

The first types of transistors to be built and used were called *bipolar junction transistors (BJTs)*. This type of transistor is similar in construction to the diode, except that there are two semiconductor junction areas inside.

This arrangement of magic beans allows a small amount of electrical current to be applied to one of the three terminals of the transistor, called the *base*, which in turn allows a much greater amount of electrical current to flow between the remaining two terminals, known as the *collector* and *emitter*.

Two complementary types of BJTs are made, depending on the way that the positive and negative semiconductors are sandwiched together. NPN transistors will conduct conventional current from the collector to the emitter when current flows from the base to the emitter. The opposite variety, called the PNP transistor, does precisely the opposite, conducting conventional current from the emitter to the collector when the base is negatively biased.

Transistors can be used to make amplifiers, switches, current limiters, voltage regulators, oscillators, and any number of other useful circuits. They are generally very low cost, lightweight, and reliable.

As with any other electrical components, you need to be aware of the electrical limitations of your transistors. Even when a transistor is fully saturated and conducting very efficiently, it's still dissipating a certain amount of its energy as heat. Too much heat and say goodbye to your transistor.

A newer type of transistor is becoming quite popular in power circuit applications, and uses a different type of semiconductor property to accomplish its mission. The *MOSFET* (*metal-oxide-semiconductor field-effect transistor*) has three terminals, just like the BJT. Each terminal performs a similar job, but does it in a different way. The *gate* of a MOSFET is electrically isolated from the conduction *channel* between the *drain* and *source* terminals. However, when a proper voltage is applied to the gate, it creates an electrical field that influences the conductivity of the channel between the drain and the source.

The important differences between BJTs and MOSFETs lie in the type of signal needed to drive each of the transistors and how much power is wasted by being converted to heat. A BJT is a current-controlled device, where more current into (or out of) the base results in more current flow through the device. The MOSFET is a voltage-controlled device, where more voltage applied to the gate increases the current flowing through the channel.

Additionally, MOSFETs typically have much lower on-state resistance than BJTs, meaning they can more efficiently switch higher currents. Finally, MOSFETs have a *positive temperature coefficient*, meaning that they conduct less power as they heat up—which is a good thing. BJTs are subject to *thermal runaway*—conducting more current as they heat up, which in turn generates more heat, and so on, until something snaps, crackles, or pops.

Integrated Circuits

As parts get more specialized, they become less fun. There are a hundred ways to wire up some transistors, resistors, and capacitors, but there's generally only one way to hook up a thermocouple interface chip.

The good news is that it has become much easier for companies to design and build vastly complex chips that can do things for us that, honestly, most people cannot comprehend. And that's OK. We need airplanes that can, mostly, fly themselves. If we had to depend on humans to get everything done, you can imagine what kind of world we'd live in. Humans are notoriously sleepy, hungry, distracted, and forgetful. A voltage comparator chip does nothing but compare two voltages, all day, every day, perfectly, all the time.

Integrated circuits come in an unbelievably wide range of functions, packages, and capabilities. The first integrated circuits were amplifiers. Integrated circuits allowed manufacturers to make chips that have dozens or hundreds of transistors and other parts *all at once*. Just plop that little silicon chip into a plastic package with legs on it, and you're done.

What kind of chips do you need in your lab? Well, that's going to depend heavily on what kind of circuits you're wanting to design, build, or repair.

Many older chips had a standard 0.1" pin spacing that made them easy to plug into a solderless breadboard for prototyping purposes. Most newer chips have been considerably shrunk, because phones and tablet computers are all the rage these days. It's still possible to work with these newer chips, but it almost always requires mounting them to some sort of breakout board or expander that brings out their tiny leads to a more reasonable, and reachable, size.

Acquiring Components

Where do components come from? The same place as everything else—the store—just like food, just like money.

The electronic component manufacturing industry spans the globe. If someone's not putting something electronic together, they're taking something electronic apart.

Once upon a time it took some hunting to find sources for electronic parts. Swap meets and “ham fests” were great places to find components, assemblies, and entire appliances just ready to be hacked, studied, improved, or rebuilt. Now you have to spend time looking for places to *get away* from all the electronic hustle and bustle.

One of the great things about today’s Internet is that it takes almost no effort to find both electronic parts and the information needed to use them. The real trick these days is finding the best deal.

If you’re strictly a hobbyist, looking to spend some quality time alone or with your kids, learning about electronics and building fun projects, then it just about doesn’t matter if you get the absolute, rock-bottom price on every component and tool. Even if you’re a budding entrepreneur, you’re still in a much better position today to leverage those brilliant ideas floating around in that noggin of yours than you would have been even ten years ago, all because of the ubiquitous nature of electronics and technology saturating our lives. Not only can you get the right tools and the best parts shipped right to your door for a song, you can easily network with knowledgeable folk from all over the globe, contributing ideas and brainstorming across time zones and borders.

Buying New Components

It would be more than a full-time job just keeping up with all of the new tools, parts, software, and hardware that are available today. Even if you could, it would take many lifetimes to make and grow the connections and relationships you need to successfully compete in the global economy.

That being said, a good place to start is in your own backyard. If at all possible, you should deal locally for the things you need. When what you want or need cannot be obtained locally, expand outward until you find it.

While it’s certainly nice to be able to find all your needs met close to home, it’s also good to know that the world is shrinking every day. The sort of deals and relationships that couldn’t possibly have existed in your parents’ time are happening right now.

If you are in a position to spend some money on quality tools and components, then by all means do so. You will not regret it. Buying questionable items is like buying your groceries out of some guy’s van in a parking lot. Maybe he’ll be there next week and maybe he won’t.

Even the small fry can get treated like an honored guest when dealing with the right people. The trick is finding the right people. The best way to find them is to ask your friends and others with similar interest where they trade. Ask them how they feel about their relationships with their vendors. Are they just a number? Or are they a partner?

Recycling Used Components

It’s really a bad idea to waste anything. In a more perfect world, there’d be no “other” category at the recyclers. Everything would have an exit strategy, especially the complex and fragile toys we’re so addicted to these days.

Until that day, try to look at your trash with new eyes. Is it conceivable that someone else might be able to use this equipment, or is it truly past its useful life? Or are you just being lazy?

You can do your part, and you should believe that others are doing their part as well. Take the time to find them, find out what they can offer you, and find out what you have that they might be able to use. You won’t know until you ask.

Be careful when harvesting components with which you are unfamiliar. Novice recyclers should give yesterday’s cathode ray tube (CRT) TVs and monitors a wide berth. They can retain *lethal* voltages for considerable periods of time after being retired from service. Just leave them on the side of the road. The same goes for microwave ovens, or any equipment that has refrigerant in it. The stuff they use nowadays is quite toxic.

There is a growing surplus of both components and “last year’s models” available to the student of electronics these days. Sometimes it’s worth your time and money just to take something apart to see how it works. Then sometimes you find some useful parts inside that you can use in projects of your own.

Component Data Sheets

Every component ever manufactured has a data sheet. This data sheet contains everything you ever wanted or needed to know about this particular component. It’s probably available right now on the manufacturer’s web site, along with a dozen application notes. If not, then it’s probably available on a university’s computer system in a project folder.

This isn’t always the case, sadly. Past a certain point, it doesn’t make sense to allocate resources to information that no one wants or needs anymore. That point varies with each company, with some diligently archiving their information and others tossing it out the window at the end of the quarter.

When possible, collect and maintain your own private set of data sheets. When you acquire a new piece of equipment, get everything you can find in electronic form and stash it away somewhere where you can find it when you need it. If you’re experimenting with some new components, squirrel away those data sheets, just in case you strike gold.

Have you built something cool? Write up your own data sheet for it! Pretend that you’re still going to be interested in this project next year. Better yet, imagine that *someone else* could take an interest in your work. You’ll be pleasantly surprised at how useful you’ll find this information in the future, after you’ve slept a bit.

Summary

This chapter has covered a lot of different types of electronic components, but it has only scratched the surface of what is presently available.

It’s perfectly possible to spend a lifetime pleasantly tinkering with electronics and never have a clue how any of the underlying principles work. Sometimes all you need is a *practical* understanding of what the different components do in a circuit. Hopefully this chapter has given you a rough outline of what is involved. Ideally, your interest has been sparked enough to pursue more detailed study elsewhere. Good luck and happy discovering!

Now that you’re armed with some basic tools and some ideas about some of the available components, it’s time to get busy building your own lab, one experiment at a time.

The remainder of this book will take you on a journey of trial, error, and experimentation that will help you build the best possible lab for your needs, both for now and in the future.

A Portable Mini-Lab

Having a portable (or at least *transportable*) electronics lab comes in handy in several circumstances. Maybe you don't have a place (yet) for a permanent home for all that equipment. Maybe you need to bounce at a moment's notice, heading off on electronic adventures at the drop of a hat. Or maybe you like to keep everything where you can find it in a hurry, without having to rummage through shelves and boxes, looking for just the right tool or component.

Whatever your motivation for wanting a portable lab at your disposal, this chapter should help you get started.

Have Lab, Will Travel

First, a note or two is in order concerning *travelling* with your electronics lab. Nothing makes security screeners at an airport or customs inspectors at border crossings more nervous than a bunch of mysterious devices, especially devices that are tangled up in a rat's nest of wires.

Do what you can to keep your collection of tools and components tidy and in working order. You will most likely be asked to at least turn on any questionable items and demonstrate that they are not hollowed-out shells for transporting questionable items. It also doesn't hurt to clearly label equipment as to its function and ownership, which makes sense in any case, not just travel scenarios.

The Compact Executive Model

"A full mongoose is a slow mongoose." This is an important lesson learned from Rudyard Kipling's *Rikki-Tikki-Tavi*. Rikki, a mongoose, has to stay fast on his feet to be able to combat Nag the cobra and hope to win. Therefore, Rikki learns to only take a few bites at a time when eating and never gorge himself.

Although hopefully not in a life-or-death situation like Rikki's, you can learn a thing or two from this simple philosophy. Only take what you absolutely need when travelling, and never take something you can obtain at your destination. These things will only slow you down. Don't be a slow mongoose.

■ **Tip** Travel light.

A slim and lightweight briefcase or attaché can hold many of the tools and components you might need for your mobile electronic experimentations. The main advantage is that you will only need one hand to carry it (leaving one hand free to open doors, bribe guards, or fend off ninja—assuming you have two hands to begin with). See Figure 4-1.



Figure 4-1. The compact executive mobile electronics laboratory. There's plenty of room for lots of tiny things, but not much else. Also handy for transporting big stacks of cash, should the situation arise.

Let's take a look at what all you can take with you without a lot of heavy lifting. Starting on the left and moving to the right, we have

- Netbook PC with AC charger and USB mouse (it might be hard to see in Figure 4-1 because it's upside down and covered by other stuff)
- Arduino Uno programmable microcontroller (or *physical computing platform*)
- Folding multitool
- Lighted magnifier
- Digital camera
- Solderless breadboard with lots of precut jumper wires
- Digital multimeter and probes
- Compact single-channel oscilloscope with probe
- AC-powered USB charger—can also be used as a stand-alone regulated 5V power supply
- USB cable
- A variety of LEDs in all shapes and sizes
- Additional passive components
- A variety of batteries, both rechargeable and otherwise, and various battery holders (not shown)
- Static-sensitive integrated circuits and modules stored in antistatic bags
- Notebooks, writing implements, blank media, and documentation
- Your contact information in case of loss

One of the interesting features of this lab is that it is completely self-contained, power-wise. While it's nice to have access to AC power, it's not strictly required, at least for a while. The Arduino and the attached breadboard are powered by the battery in the netbook, via the USB cable. The multimeter has its own 9V battery, while the mini-oscilloscope can be recharged from a spare USB connector. With an extended-life battery, you can expect four to five hours of on-location electronic experimentation.

If your netbook or PC has Wi-Fi or other connectivity to the Internet, you can browse tutorials, data sheets, user forums, and even this book, unless you've already downloaded these items to the internal hard drive.

Have a look at this particular lab deployed and ready for action in Figure 4-2.



Figure 4-2. The compact executive lab is deployed on a desktop. You have access to lots of electronic building and debugging capabilities in a small area. Using a solderless breadboard helps reduce the number of fabrication tools that you need to carry with you on your adventures.

The Arduino was included for its small size, popularity, and ease of use. There's a whole world waiting for you inside that little board, waiting to be explored, but that's a story for another day.

You can use the USB cable to extract a regulated +5V supply from your PC for your low-voltage-experimenting pleasure. You can also use an inexpensive USB charger to do the same thing, if you don't feel like hauling a whole PC around with you. Just don't try to draw more than half an amp of current, which is the "official" USB limit for supplying power to USB devices. Technically, *unenumerated* devices (i.e., just a USB cable with nothing intelligent enough to identify itself to your computer) can only draw up to 100 mA (0.1A) of current. A USB charger, on the other hand, is not so picky.

No Soldering Required

One notable omission from this particular configuration is any sort of soldering tool. You could certainly add a small soldering iron, some solder, and a few more hand tools. You'll either need to boot out some of the bulkier items, such as the PC or the full-sized multimeter, or get a slightly bigger carrying case.

The Ever-Shrinking Computing Device

One option that will be gaining momentum in the very near future is the use of tablet computers or smart phones instead of the physically larger laptops or netbooks. They already have a lot of the computing capabilities of reasonably powered portable computers. Also, you can look forward to innovative hardware and software interfaces that will make them more useful in the lab as programmable test and measurement devices. While name-brand products still command a premium price, many no-name or OEM (original equipment manufacturer) products are being sold for a fraction of the cost.

Electrical Experiments You Can Perform

Here are some simple electronic experiments that you can perform using only the tools and components found in the compact executive mobile electronics lab. Start out with something simple and incrementally build on your success. Don't try the most complex problems first. What you want is to build up both your knowledge *and* your confidence at the same time.

Lighten Up, 20th Century Style

Here's an easy experiment that will teach you several interesting things about electronics, believe it or not. You can light up a typical LED using only a lithium coin cell. It needs to be a lithium coin cell that produces at least three volts (marked "3V"), not one of the smaller batteries that only supplies 1.5V, such as a watch or hearing-aid battery, as these will not produce enough voltage to light up a typical LED.

Slide the coin cell between the leads of your LED. There are four possible outcomes, three of which are "nothing interesting happens." Let's start with the least likely possibility, in which the LED lights up. Sometimes you just get lucky.

First Possible Outcome: The LED Lights Up When Attached to the Coin Cell

Figure 4-3 shows the results of this outcome. Notice that the longer lead of the sLED (the positive, or anode, lead) is touching the side of the coin cell marked with a +. No current-limiting resistor is required in this circuit because the battery's internal resistance is sufficient to keep from blowing up the LED. It just happens to work out that way, this time. Most other times, you will need to add a current-limiting resistor to the circuit.

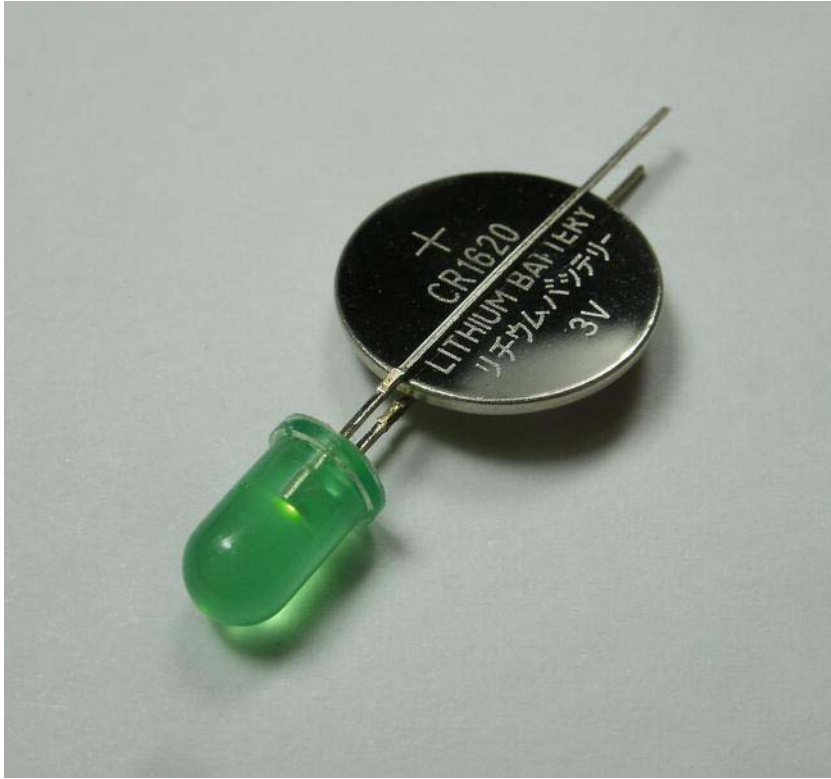

Figure 4-3. A typical LED lights up when attached to a lithium coin cell. No extra wires needed!

The other three scenarios? Let's look at them one at a time.

Second Possible Outcome: Nothing Interesting Happens

Why? Because the LED has been installed backward. Alternatively, the coin cell has been installed backward. Remember from Chapter 2 that LEDs are light-emitting diodes, and diodes only carry current in one direction. Therefore, when connected backward, they block the flow of electric current, preventing anything interesting from happening in the rest of the circuit.

Typical lithium coin cells have one broad, flat side that usually has something printed or etched on it, almost always with a + to indicate the positive polarity of the cell. The other side is often textured or rippled in some way to help make better electrical contact when installed in a device. This other side is the negative terminal of the battery.

The LED, being a diode, is *polarized*. It will only work when installed in the proper orientation inside the circuit. Most LEDs will offer one or more ways of easily identifying which lead is which (see Figure 4-4).

- Brand-new LEDs will have extended leads about an inch or so long. One lead will be slightly longer than the other one. The longer lead is the *anode*, or positive lead. The shorter lead is the *cathode*, or negative lead. This information is lost when the leads of the LED are trimmed—for example, after being installed in a PCB.
- Another industry standard for identifying the polarity of an LED is to look at the small ridge or shoulder at the base of the LED body. There will be a flat portion molded into the otherwise circular outline. This flat spot marks the cathode, or negative terminal of the LED.



Figure 4-4. Typical LEDs in the 3mm, 5mm, 8mm, and 10mm sizes almost always have two polarity indicators. The first is that the longer lead is the positive lead, or anode (top). The second is that the flat side on the base indicates the negative lead, or cathode (bottom).

On really tiny LEDs, there may be an even tinier mark printed or etched onto the LED to indicate the cathode. You will sometimes need a magnifying glass just to see it!

The quick and easy fix for this problem is to swap the direction of either the LED or the battery. If this still produces no good results, we have to consider some more possibilities.

Third Possible Outcome: Nothing Interesting Happens

This time, after establishing that the LED has been properly oriented with respect to the polarity of the battery, we must entertain the possibility that the battery has been previously depleted. Coin cells have a limited amount of energy stored within them, and this can be easily drained in normal use over time.

A quick way to measure a battery's electrical goodness is to use a voltmeter. See Figure 4-5.



Figure 4-5. Measuring a coin cell's electrical goodness using a digital multimeter. This one is chock-full of goodness!

If you have a multimeter, be sure to set it to read DC voltage, in the appropriate voltage range (unless you have a fancy “autoranging” meter). Touch one of the meter’s probes to one side of the battery and the other probe to the other side of the battery, and see how much voltage is measured. Anything below 3V should be considered depleted and of no further use, as far as electronic-type projects are concerned. The batteries are shiny and round, so they may have a second career in some sort of art project, but otherwise they should be disposed of in a responsible manner.

Also, perhaps because of their very shininess and roundness, they like to be eaten by small children. Don’t let this happen! Take whatever steps are necessary to prevent small children from handling or even touching your electronic tools and components. Use extra care when your lab is mobilized.

■ **Caution** No unsupervised children, no matter how adorable, are allowed in the lab!

Fourth Possible Outcome: Nothing Interesting Happens Because the LED Is Defective

This can happen when an LED is subjected to too much current and the tiny, tiny wires within the plastic body overheat and fail. It can also occur when the LED has been exposed to the elements and moisture has penetrated the casing, allowing the internal connections to oxidize. This scenario, while within the realm of possibility, is certainly the least likely of the four, unless you are habitually cruel to your LEDs. It's also easy to test, if you have a known-good lithium coin cell handy.

Where's the Resistor?

You might be wondering where the current-limiting resistor can be found in this circuit. It's in there, all right, but it's hidden within the battery, so to speak. Coin cells are designed to provide tiny amounts of current over a long period of time. You're not going to arc-weld or start your car with one. As such, they have a much higher *internal resistance* than most any other kind of battery. We use this "feature" to our advantage when testing LEDs using just a coin cell, as the maximum amount of current that will normally flow out of the battery is below that necessary to destroy the LED.

A Slightly More Permanent Circuit

You can build a more permanent circuit for the coin cell and LED using a solderless breadboard. If you recall from the "Solderless Breadboards" section of Chapter 3 (see Figure 3-6), a solderless breadboard is an array of spring-loaded tie points, which serve to both physically hold electronic components and provide electrical connections between certain points. Let's build an LED circuit on a solderless breadboard using an LED, a coin cell, a resistor, a jumper wire, and a custom battery holder (see Figure 4-6). Later on, in Figure 4-7, you can see details of the custom battery holder.

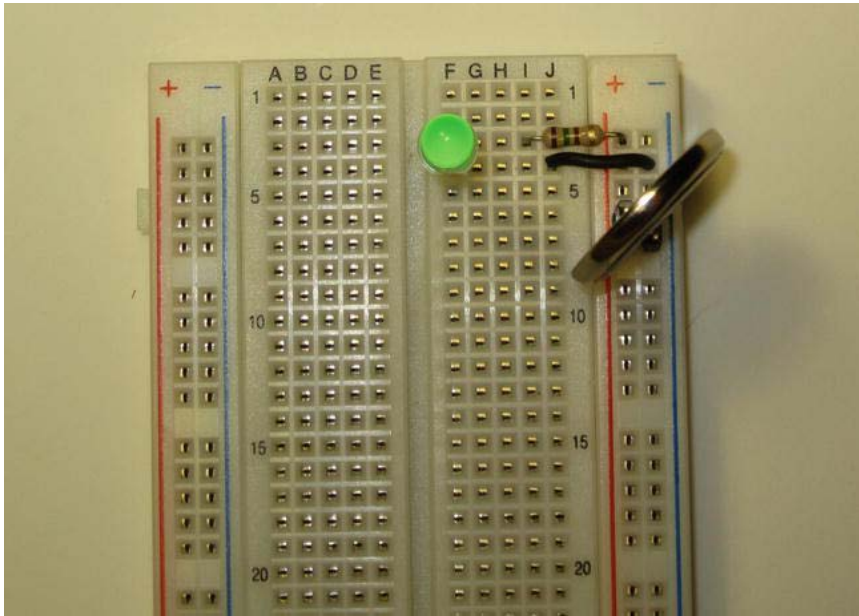

Figure 4-6. A slightly more permanent LED circuit, built on a solderless breadboard. The tie points on the breadboard are labeled left to right with the letters A–E and F–J for the columns. The rows are numbered starting at 1 at the top. The LED’s anode, for example, is installed in tie point F3. The power rails on either side are simply marked with + for positive and – for negative.

Referring again to Figure 4-6, you can see the overall layout of the LED circuit. The power rails along both sides of the breadboard are just longer versions of the electrical connections that connect each of the groups of five tie points together. In this example, the right-hand power rails are used, but the left-hand side is not.

The schematic diagram of this circuit shows how simple it is, at least in principle (see Figure 4-7). Can you see the circle?

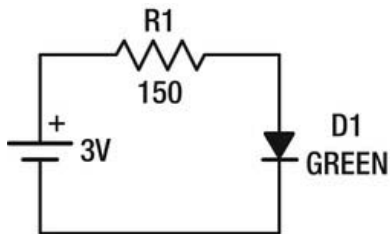

Figure 4-7. The schematic diagram of the LED circuit as built on the solderless breadboard. Schematics are intentionally simpler than reality (most of the time) in order to help convey the very basic idea of how things are to be wired and the relationships between the components, without bogging you down in all the inevitable details that are involved.

The Battery

The symbol for the battery actually looks like the battery in this case. The same symbol is used for most single-cell batteries, even when they are of completely different shapes or proportions. Multicell batteries are usually represented with repeated stacks of long and short lines.

The battery symbol's long line represents the positive terminal of the battery, and the short line represents the negative terminal. Again, it's just a coincidence that the wide side of the lithium coin cell is the positive terminal. The addition of the + sign in the schematic is redundant, but you'd be surprised how many people accidentally reverse this symbol. Better safe than sorry when it comes to electricity!

The Resistor

The battery's positive terminal is connected via a wire (drawn as a simple, solid line) to one side of the resistor. The schematic symbol for the resistor is a zigzag line.

The resistor is labeled "R1" (resistor 1) in this schematic, even though it's the only resistor and could just as well have been labeled "RESISTOR #1," or just plain "resistor." The numeric value underneath the resistor is the component's primary electrical characteristic, at least as far as we're concerned when looking at the schematic. In this case, it indicates a resistor whose *value* is 150Ω. In this simple example, the value of the resistor is quite flexible. A larger value, such as 1KΩ (1,000 ohms) or more, would also work, except that the LED would not shine as brightly. This is because *more* resistance results in *less* current flow, and it's the current flow that makes the LED shine. More current, more shiny.

We haven't specified any of the other important characteristics of the resistor, such as the tolerance or the power-handling capacity. Because this is such a low-power circuit, almost anything will do. When you start to work with really big LEDs that require correspondingly really big power supplies, this becomes a much more critical issue. For now, we start simply.

The LED

The other side of the resistor is connected, again, with a simple, solid line, to the anode of the LED, whose *reference designator* in this schematic is D1 (for diode 1). You could have called it "LED," and future generations would probably have understood your intentions, which should be your overriding goal. Its characteristic "value" in this case is "green." Of course, any color will do, as long as you have the eyes to see it.

The LED's schematic diagram effectively communicates its polarized nature. The arrow indicates the flow of *conventional current*. The flat bar indicates the cathode, or negative terminal of the LED. This corresponds to the flat side of the LED body in this example. The cathode is connected via a wire back to the negative terminal of the battery, completing the circuit.

Can you see the circle yet? Hint: It's disguised as a rectangle. The important point is that it forms a complete loop.

Building the Actual Circuit

Comparing the schematic to the photograph of the completed circuit might not immediately click in your head. Take a look at Figure 4-8 for a slightly different angle, where you can see some more details, such as how the battery is being mounted.

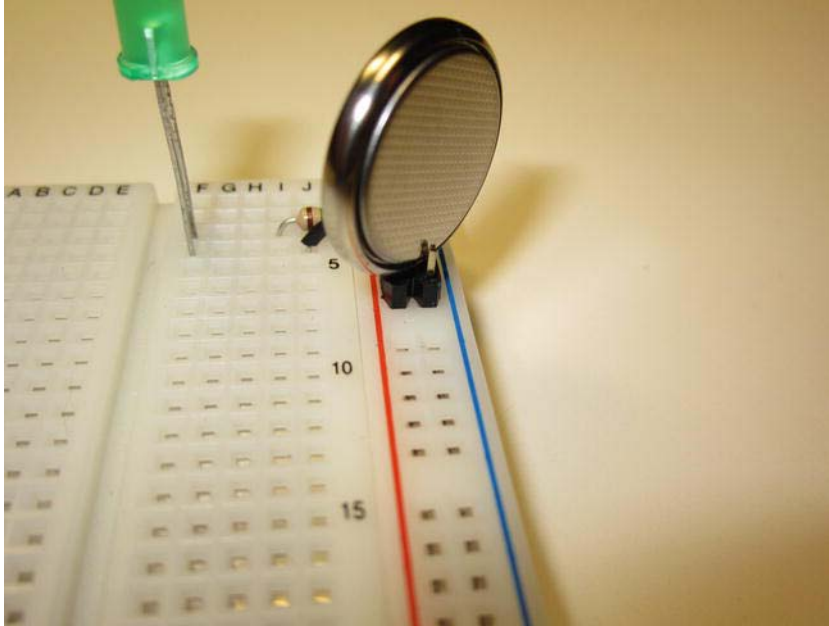

Figure 4-8. Another view of the LED circuit as built on a solderless breadboard. The battery holder is a modified pin block that has had a couple of its pins removed, allowing the coin cell to fit in on the diagonal. A thinner coin cell could have fit without your having to remove the corner pins. A proper coin cell holder is inexpensive and would provide a much more robust solution to the problem.

Looking at Figure 4-8, you can see how the positive side of the battery is making physical and electrical contact with the gold-plated pin of the pin block. The remainder of the pin emerges underneath the black plastic molding to make contact with the spring-loaded tie point within the body of the solderless breadboard, which in this case is the negative power rail. The positive terminal, in a similar fashion, makes contact with the positive power rail.

By attaching the battery directly to the right-side power rails, you ensure that your circuits are only a short jumper away from power, no matter where along the breadboard you decide to build them. Handy!

Note that the left-side and right-side power rails are not connected at this time. If you would like them to be, you can easily attach them using jumper wires. See Figure 4-9.

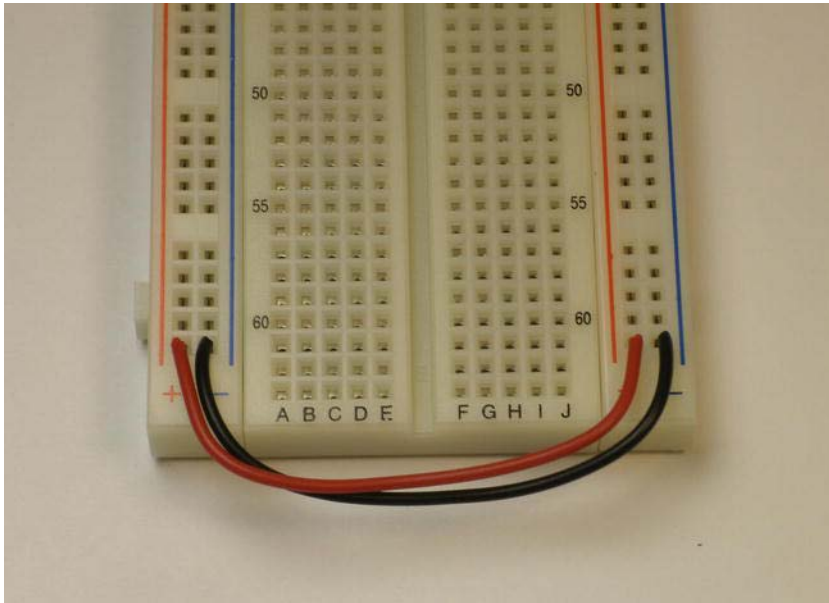

Figure 4-9. Attaching the left- and right-side power rails using jumpers. By default, the power rails are not connected. There are some situations where you need them to not be connected, such as when using multiple supply voltages within a single circuit. These things happen.

Now, referring *all the way back* to Figure 4-6 (sorry about that), you should be able to see how the positive terminal of the battery is indeed connected to one side of the resistor. The other side of the resistor, then, makes an electrical connection with the anode of the LED (the non-flat side, when seen from above). The cathode is connected to the negative power rail using a short jumper wire. The negative power rail then completes the circuit back to the battery. The circle is complete.

Note that the resistor could have been placed either before the LED in the circuit (as shown in the photographs) or after the LED. The only important points are that it is in the same circuit, or circle, and that the current must flow through *both* the LED and the resistor. It really doesn't matter which one comes first, especially in this simple circuit. It will only make a difference when you start to do fancy stuff, like adding switches and such to complicate things.

If you're using a different kind of solderless breadboard (and there are a few distinct varieties), you may or may not have power rails available. If so, fret not. You can still make point-to-point connections using more jumper wires. Now you're starting to understand why you were assigned to cut and strip so many jumper wires back in Chapter 2! They should start to be coming in handy just about now.

Multiple Uses for the LED

Now we've moved from the 19th century incandescent bulb to the 20th century LED. What kind of lighting devices will we encounter in the centuries ahead?

One of the nice features of LEDs is that they don't typically require a great deal of power to operate. This is certainly true of indicator-style LEDs, whose only purpose is to be seen as either on or off. We can leave this LED installed right where it is and use it as a handy power-on indicator for future projects. You might be surprised how many heads get scratched in puzzlement, wondering why a newly wired prototype isn't working, only to find out after exhaustive investigation that the power wasn't turned on! Then again, you might not be surprised by this.

Now let's take this perfectly working circuit and break it—on purpose. If we interrupt the circuit, for example, by removing any of the components or their connections, the circuit stops working. To that end, remove the short jumper wire and replace it with two longer jumper wires. Plug in each of the new, longer jumper wires where the two ends of the short jumper were installed. See Figure 4-10.

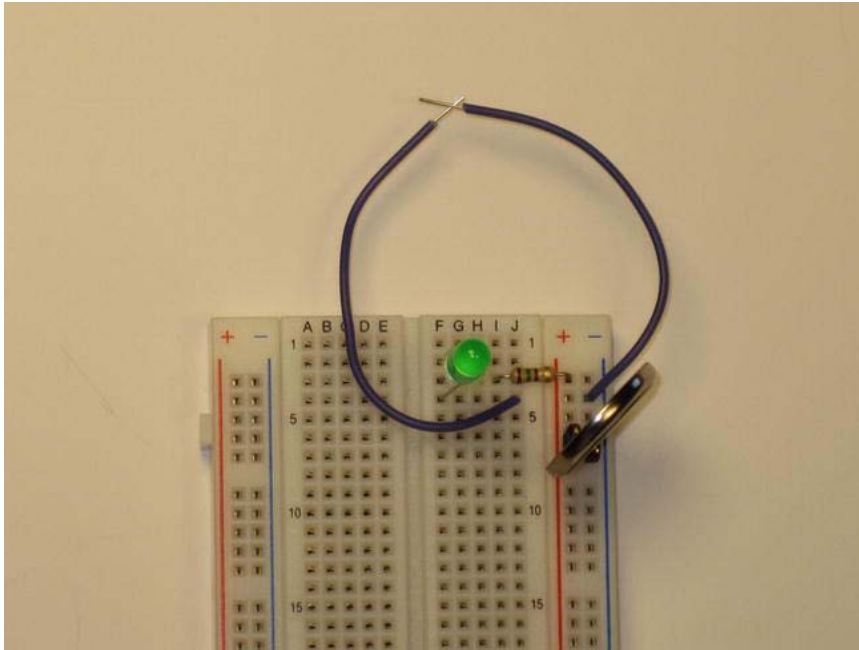

Figure 4-10. By intentionally breaking the circuit, we stop the flow of electricity through the components, extinguishing the LED. By reconnecting the longer jumpers (or just touching them together), we reestablish the circuit, and the LED should light back up again. We can use this mechanism to test whether there is continuity in another circuit.

Now, by touching the two probe wires together, you recomplete the circuit, and the LED should glow in happiness. This is exactly how a switch works. You can use this basic idea to build a continuity tester that lights up the LED when the current flows in the circuit. This is very handy for testing cables and wiring in a more complex assembly.

More electronic experiments, including how to both calculate and measure what's happening in a circuit, can be found in Chapter 5.

The Special Project Portable Laboratory

When you move past the simple joys of lighting LEDs and wiring up tutorial circuits, where do you go and what do you build? How about a robot?

Doug Paradis is an award-winning writer and robot builder. When Doug wants to work on one of his robots, he packs up a small kit of tools and heads over the local robot club, which in Doug's case is the Dallas Personal Robotics Group (DPRG). They meet every Tuesday at the Dallas Makerspace for an informal evening of robot building and socializing. See Figure 4-11.



Figure 4-11. Doug Paradis of DPRG, arriving at the Dallas Makerspace for an evening of robot building. Doug uses the club's laser cutter and other specialized tools to give his robots that winning edge. He brings his own set of hand-picked tools along with him.



Figure 4-13. A sort-of-portable robotics lab, with lots of tools and spare parts. One way of looking at this bounteous splendor is “three trips to the car.”

This caravan of tools, parts, and miscellaneous supplies forms the entourage of Kyle the Robot. Kyle is very much a work-in-progress. The basic framework is made of hand-tooled aluminum. The large wheels use O-rings for tires and are driven by 24V gear motors. The 24V supply is made up of two 12V, 5Ah rechargeable lead-acid batteries. Ah stands for amp hours, and represents the capacity of the battery. In this case, it can deliver an amp of current for five hours, or five amps for one hour. The custom PCB holds the electronics for the drive motors and will be controlled by a separate microcontroller that has yet to be added. See Figure 4-14.



Figure 4-14. Kyle the Robot is a work-in-progress who requires a wide range of specialized tools and components. Some new components are being fitted, including dedicated battery voltmeters, fuses, a circuit breaker, and a master power switch. Once the sharp corners are filed off, Kyle will be able to roll around the house, looking for chores to do.

Summary

As we come to the end of this chapter, you should have some good ideas bouncing around in your head about how you want to pack your mobile electronics lab, what tools and components you *absolutely* must have with you, and how you want them organized. The best way to find out for sure what works for you is to make a few field trips, paying careful attention to what was actually used compared to what you anticipated needing. This will help you whittle down your cargo to the bare essentials, which is what you want. Remember, travel light. Excess baggage is a purely optional curse.

In the next chapter, we'll look at some suggestions for organizing and working in a more permanent setting. This could be a domain as small as the corner of a desk or as large as a warehouse. You will soon discover, if you haven't already, that this hobby, like many other projects, will quickly expand to fill the space available. Try to keep in mind that *you* are the one that ultimately makes the decisions. Effort spent planning ahead of time will help keep the sprawl to a minimum, while helping you stay focused on what you wanted to be able to do in the first place.

The Cozy Corner Lab

Chapter 4 focused on the needs of the travelling electronic adept. Here in Chapter 5 you can come home to a lab that is always ready and waiting for some electrical fun and doodling. Nice!

You don't need an entire garage or extra office for a functional laboratory for your electronic endeavors. It's certainly nice if these areas are available to you, but you might be surprised at how much you can do in just a small space, if you set it up properly and maintain it with determination.

The first part of this chapter will deal with the task of rehabilitating a small, dedicated work area that has succumbed to years of poor organizational habits. These things happen. The second half of the chapter explores the possibilities of starting afresh with a nice, clean space—either something brand new or just newly cleaned. Some more projects help break in your new work area, as well as familiarize you with more interesting information about some of the basic electronic components reviewed in Chapter 3.

The Rehabilitation of a Small but Useful Area

Let's perform a little magic, in the form of a complete makeover for a small workstation. Have a look at Figure 5-1. Don't let this happen to you!



Figure 5-1. A workstation that has been in continuous use for several years. Not much planning went into the original organization of this work area. Such a space can often accumulate flotsam and jetsam that might have at one time seemed appropriate, but now just competes for precious space. The effective work area is down to only a few dozen square inches! This limits the scope of projects that can be comfortably undertaken. It also causes unnecessary delays in rooting around for tools and parts. It's not pretty and it's not safe.

Where to begin? Like any other project, this big project is made up of many smaller projects, none of which are especially difficult, if approached in the right order and with the right attitude.

If you're starting from scratch with your electronics lab and don't want to wade through this mess, jump on over to the "Adding a Power Source" section of this chapter.

Science to the Rescue!

Let's use the science of *taxonomy* to help break down this task into smaller, more manageable jobs. Taxonomy comes from the Greek words for "arrangement" (*taxis*) and "method" (*nomia*). That sounds like *exactly* what is needed here! An "arrangement method" would assist in building up a plan for attacking this project.

■ **Tip** Method plus rigor equals success! Have a plan, pursue it with determination, and you will succeed.

Let's break down the overall category of "big mess on table" into two major *taxa* (singular: *taxon*), or categories. Ideally, what we will find here are *tools* and *components*. There will be other bits and pieces that don't easily fit into one category or the other (or will maybe fit into both), but it gives us a place to start.

Organization

Divide and conquer! These are the two words that will help us through the ordeal of rehabilitating this workspace. We'll get to do a lot of dividing here, and end up as conquerors. The spoils will be a useful (and tidy!) work area that will encourage you to begin new electronic adventures, instead of scaring small children.

The Great Divide

It would be possible to reorganize this workspace *in situ* (i.e., in place), but it would require a great deal of inner peace and lots of patience. Lacking these, a complete reboot is in order. Let's clear off the entire table and start afresh. This will provide the excellent opportunity to arrange things in exactly the best possible order.

First, get two big containers. These can be cardboard boxes or plastic storage bins—it really doesn't matter. We'll just be using them as temporary staging areas as we make like an embryo (and divide and divide again). See Figure 5-2.



Figure 5-2. Two large cardboard boxes are enlisted to help with the initial organization of the contents of the tabletop. One will be for tools and the other one for components. Further subdivisions will be made later.

Now, the first thing you will want to do is remove any items that really don't belong in the lab at all, such as coffee cups, personal effects, and any obvious trash. Everything that is about to go into one of the two boxes should eventually find its way back to the work area, so now is the time to omit the things just don't belong here.

Is it a tool? Is it a component? How do we tell? Ask five people and you will get five different answers. For the purposes of this little endeavor, a *component* is something that will become a part of a project, while a *tool* is something that is used to modify or manipulate a component. Another way of looking at it is that components get used up quickly, while tools get used up slowly. If you build enough projects, you will be lucky enough to see exceptions to these guidelines.

Here are some examples. Wire is a component. Wire cutters are tools. That was easy. A flashlight is a "visual inspection aid," so it goes under the category of tools. Batteries for the flashlight are consumable, so they are components. There's no real need to be ultra-precise at this point. Use your best judgment and make up policies that make sense to *you*.

It might help, from a physical logistics standpoint, to use smaller subcontainers to hold the really small bits as you're lumping them into the two broad categories. Folding cardboard bin boxes are handy both on the tabletop as well as on shelves, if you have them. The cardboard bin boxes shown in Figure 5-3 are from Uline (<http://uline.com>), part numbers S-16268 (4" wide) and S-16269 (6" wide).



Figure 5-3. Folding cardboard bin boxes help contain some of the smaller bits and pieces during the Big Sort. You can use whatever happens to be available. Some preliminary subsubdivision is going on here. For the most part, the tools are on the left and the components are on the right.

After everything is removed from the table and the cardboard boxes are nearly full, the table itself should get a good washing. Behold the *tabula rasa* (blank slate) depicted in Figure 5-4.



Figure 5-4. The tabletop has been cleared of tools, components, and various bits of debris. A good washing with soap and water completes the cleansing. A burned spot (the result of a poorly supervised thermal test) is covered with a small sticker (see inset).

Adding a Power Source

Here's where a bit of planning will save you a lot of headaches in the future. What you never seem to have enough of in any laboratory, especially electronics labs, are lots of conveniently located power outlets. Let's take care of that issue right away, before building anything else onto the tabletop. See Figure 5-5.



Figure 5-5. A 12-outlet power strip is attached to the back edge of the tabletop. This will provide a safe and convenient source of power for all those gadgets you'll eventually want on your bench. Tools needed for the job include a drill motor to drill out some small pilot holes for the brackets, a small drill bit, and a felt-tipped marker. Before drilling the pilot holes, align the brackets where you want them to go and use the marker to put a dot where the pilot hole should be drilled. Make sure the power strip is not plugged in when you're drilling right next to it!

Having lots of extra power outlets is a nice bonus, but is not absolutely required. What you want to avoid, however, is excessive daisy-chaining of power strips and extension cords. This is a fire hazard. Remember from Chapter 3 that every conductor has a certain amount of resistance. This resistance turns electricity into heat. Enough heat makes things catch on fire.

If you do have the luxury of being able to mount a permanent power strip (which, technically, remains a temporary power tap as far as the manufacturer is concerned), then be sure to install it securely using the hardware provided. See Figure 5-6.



Figure 5-6. The power strip is fastened securely to the table using the provided hardware. You do not want your power strip wiggling around, or worse yet, falling off the table, dragging all of your power tools with it!

■ **Tip** Test every outlet of your power strip before permanently mounting it to your workbench.

A Clean, Well-Lighted Space

You can never have enough light, it seems. What passes for normal room illumination might be sufficient for such adventurous undertakings as finding your way to the door or looking for the remote control for the television. For anything more demanding, you're going to have to add some more lighting, and probably lots of it.

At a minimum, you are going to want some *task lighting*, which helps illuminate the immediate area of your focus. In this case, where a small table is being used as a workbench, an articulated fluorescent lamp with a built-in magnifier will do a great job, at least until more lighting can be strung up. See Figure 5-7.



Figure 5-7. You will need some task lighting for your bench. This desk lamp also includes a handy magnifier for really close work.

Tools

Now we're ready to bring some of the tools back in to the lab. Here's where you get to decide which tools get a *permanent* home on the bench and which ones get put up and stored when not in use.

The permanently deployed tools on your workbench should be the ones that you find that you are using the most. The ones that get put up after every use are the ones that either only get used infrequently or pose some sort of hazard, such as sharp edges or hot surfaces. Again, you get to decide. It's your lab.

Tools for Soldering

An activity that is practiced frequently in many electronics labs is soldering. If you haven't learned how to solder yet, you are strongly encouraged to do so. Here's a handy setup for soldering, sitting in one corner of the newly refurbished workbench. See Figure 5-8.



Figure 5-8. A temperature-controlled soldering station with a stand for the soldering iron, a water bottle to wet the tip-wiping sponge, and some different kinds of solder. Some people prefer to have the soldering station nearer to the front edge of the table. Use whatever configuration makes the most sense in your lab.

■ **Caution** Soldering irons are hot and can cause serious burns. Do not place a soldering iron where you might accidentally knock it off the work table or brush against it.

Hand Tools and Some Test Equipment

No matter what you work on at the bench, you will most likely discover the need for some common hand tools. When working with electronics, especially, you will often need wire cutters, wire strippers, and small pliers. These tools have been laid out conveniently (for a right-handed person) at the lower-right-hand side of the bench, while the less-often-used hand tools can reside in a box.

A regulated, adjustable bench power supply is also very handy when working with electronics of all kinds. A good, reliable multimeter can also claim a permanent home on the bench, as these will get a lot of use. See Figure 5-9.



Figure 5-9. A clean bench with just enough tools to have some fun. Extra soldering supplies, including more kinds of solder, extra soldering iron tips, soldering flux, and an emergency backup soldering iron, sit in a box adjacent to the soldering station. Hand tools and basic test-and-measurement equipment complete the set of “most-useful tools.” There’s still room for a few more, when you need them.

Under the Desk

If your workbench has the luxury of drawers, by all means use them! Try to keep your under-desk environment as free of clutter as possible. It's not really a very convenient place to store unused tools or components. You're going to drop the occasional item from time to time, so having to dig out a bunch of junk just to find it is just going to be more frustrating for you. Keep it clean!

You *should* keep a medium-sized trash can under or near your work area, as you will inevitably generate some waste products in this hobby. By minimizing the amount of food-related garbage deposited in your laboratory trash receptacle, you can postpone the invasion of little critters looking for a free meal. Also, bits of wire and old components don't tend to stink after a few days, but a half-eaten sandwich might.

■ **Tip** Copper easily recycles at a premium price. Collect your copper wire snippings and cash them in someday.

A nice addition to the under-the-table accessories you might consider is some low-wattage strip lighting. LEDs are especially good for this. You will appreciate this more once you conduct your first search-and-rescue mission for that teensy-tiny component that dropped off the edge of your table and into the carpet.

Components

Most of our tools are now ready to go. The most frequently used tools are permanently set up, ready for action. The less frequently used tools are carefully stored where we can get to them when we need them, but are not in the way the rest of the time. This is a big improvement over the situation you saw back in Figure 5-1.

Now we need some components with which to work, using our scientifically arrayed tools. Have a look at Figure 5-10 to see one example of how to keep your parts organized yet within easy reach.



Figure 5-10. Parts bins are used to organize components. This style of container is available in many sizes with different numbers and sizes of drawers. Even more parts are stored on a shelf behind the work area. The most commonly used hand tools are laid out on the right. The other hand tools are collected in a small toolbox on the left.

Where to Go from Here

This work space could be further augmented with shelving, both above the work surface and underneath. More lighting wouldn't hurt, either. However, this is plenty to get started. Let's build some electronics projects on this squeaky-clean table and see if we can dirty it up a bit.

Projects

Let's look at a few smaller circuits you can easily build on your tidy, new work area using a solderless breadboard. Expanding on the LED-and-coin-cell experiments in Chapter 4, we'll add a few more components and hopefully start to see how they all interact.

There are any number of different types of solderless breadboards available today. A range of them is shown in Figure 5-11.

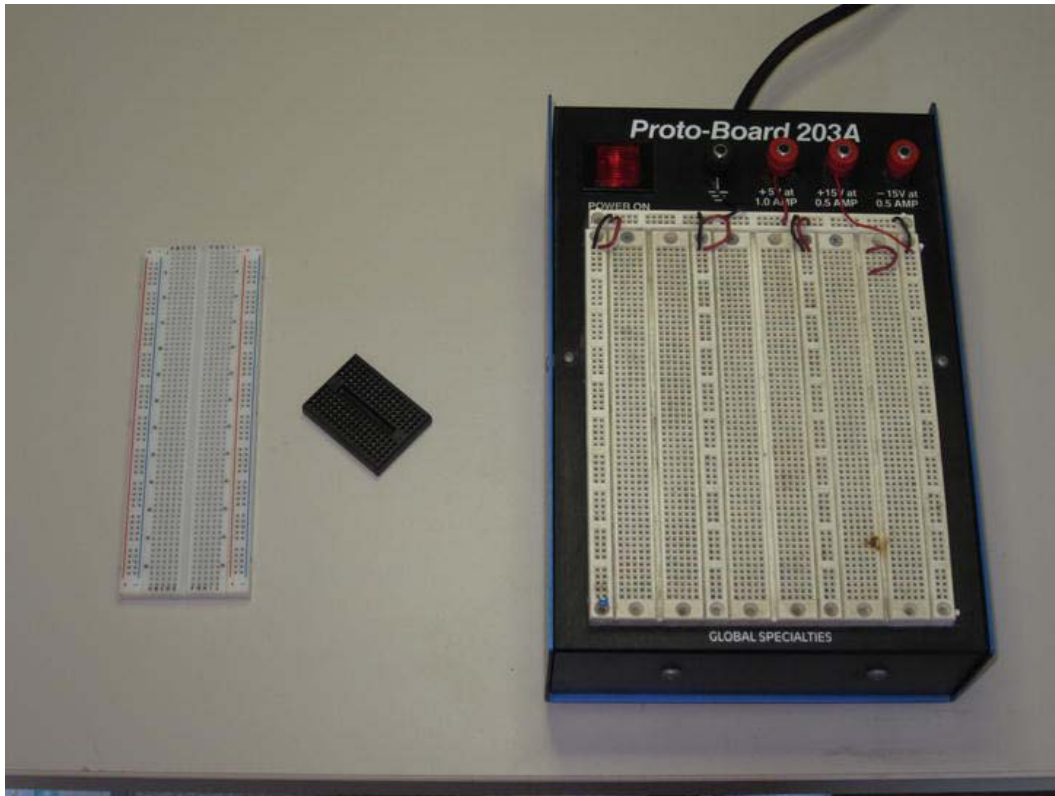

Figure 5-11. Different sizes of solderless breadboards, all with the same lead pitch and internal connections. The small black unit in the center is perfect for little circuits with only a few small components. The white unit on the left has more tie points and offers power rails along each side. The deluxe, powered unit on the right adds even more space, as well as multiple regulated power supplies for all your tinkering requirements.

Parallel and Series Circuits

The circuits presented so far have all illustrated the “loop” characteristic of electrical circuits. Electricity generally flows in a circle. It’s possible to have more than one path through a circuit, however. What happens then?

Like most good questions, the answer is, “It depends.” Let’s hook up *two* LEDs at once and try to figure out exactly what’s going on. Figure 5-12 shows how it’s put together. See Figure 5-13 for the schematic diagram.

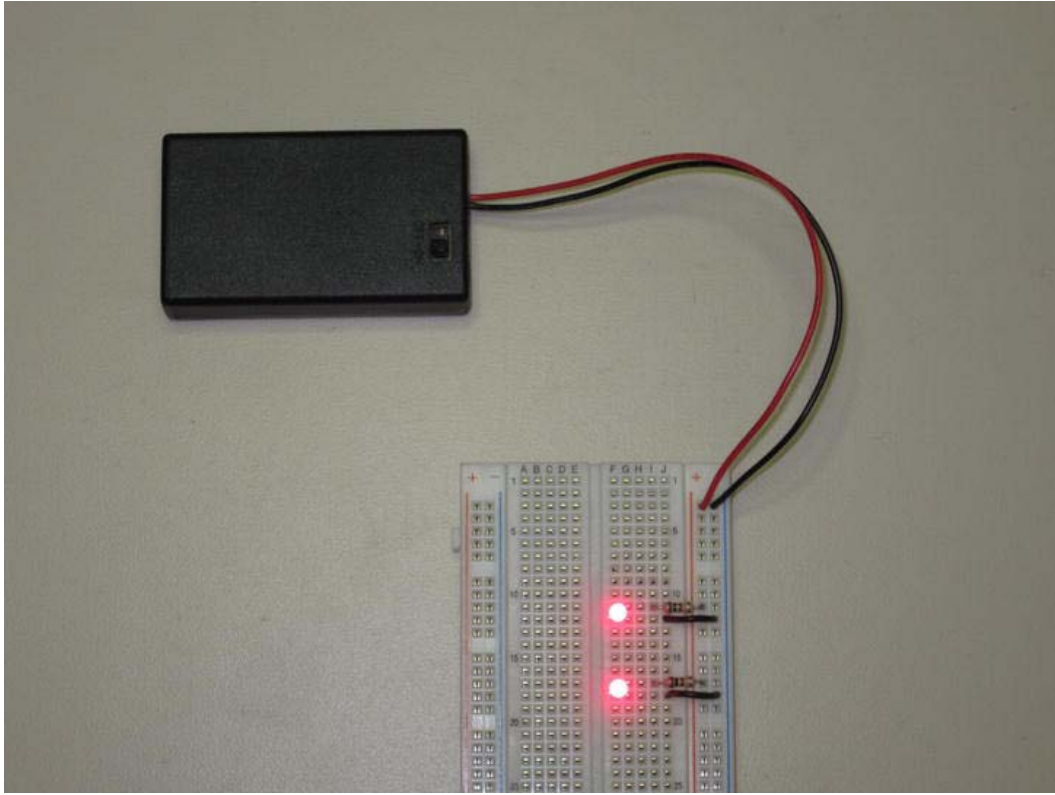

Figure 5-12. Two LEDs are illuminated at the same time. This simple circuit demonstrates both parallel and series electrical circuits. A 3×AAA battery holder with an integrated power switch is used to provide power to the circuit.

To build this circuit as shown, you will need the following components:

- A solderless breadboard with power rails
- A 3×AAA battery holder (which holds three AAA cells) and three fresh AAA cells—rechargeable cells are better
- Two LEDs (any visible color will do)
- Two 100Ω 1/4W resistors
- Two short jumper wires

Using the letters printed on the breadboard to find the columns across the top and the numbers to find the rows, we can describe each of the tie points using a single letter and a number, such as A-1 or B-2. The following exercise shows how to put it all together.

ASSEMBLY INSTRUCTIONS

1. Install the top LED with its anode (longer lead) in tie point F-11 and the cathode in tie point F-12.
2. Insert one of the resistors from the red power rail on the right at row 11 across to tie point I-11.
3. Connect the right-hand blue power rail at row 12 to tie point J-12 using a short jumper wire.
4. Install another LED just below the top LED, with its anode in tie point F-17 and the cathode in F-18.
5. Install the other resistor from the right-hand power rail at row 17 across to tie point I-17.
6. Use another short jumper wire to connect the blue power rail on the right at row 18 to tie point J-18.
7. Install three fresh AAA cells into the battery holder.
8. Insert the red wire (positive) coming from the battery holder to the red power rail on the right at row 3 (the top).
9. Insert the black wire (negative) from the battery holder to the blue power rail on the right at row 3.
10. If your battery holder has a power switch, turn it on now.

The circuit is now complete. Please verify that both LEDs are illuminated, as shown in Figure 5-12.

Troubleshooting

If both LEDs are not shining at this point, you're going to have to do some troubleshooting.

- The first thing to do is double-check your wiring. Does your breadboard look like the one in Figure 5-12?
- Next, make sure you're using good batteries. If you have a voltmeter, you can test the batteries by measuring their voltage. New alkaline or carbon zinc cells should read 1.5V or more. Rechargeable nickel-cadmium (NiCd) or nickel-metal hydride (NiMH) batteries should read around 1.2V each when completely charged.
- Are the cells properly installed in the holder? Are they in the proper orientation and firmly seated?

- Is the power switch (if available) not in the On position? This happens more frequently than anyone would like to admit. Wiggle the switch back and forth and see if it's only making intermittent connection.
- Check the orientation of the LEDs. They will only work if installed in the correct orientation. It only takes a second to unplug them, swap them around, and try them the other way. At these low voltages, it won't hurt them to be installed backward.
- Are your resistors the right value? The 100Ω value is not critical. Anything from 100Ω to 1KΩ will do nicely. Don't use smaller values, as this will allow too much current to flow through the circuit, perhaps damaging the LEDs. How much current? We'll figure that out in just a bit. Larger-value resistors will decrease the amount of light emitted by the LEDs, down to the point where you can't see them anymore.
- Are you sure your LEDs emit visible light? Millions of infrared LEDs are manufactured every month for use in remote controls and night-vision gear. This light is not visible with the human eye, although some digital cameras can see it. Just because it looks like an LED doesn't mean it *is* an LED.

A Different View of the Same Thing

Your version of the circuit in Figure 5-12 might look a little different, and that's just fine. The important point is that both LEDs are lit up at the same time when you apply power.

Let's look at the traditional schematic for this circuit to get an idea of what's going on here. See Figure 5-13.

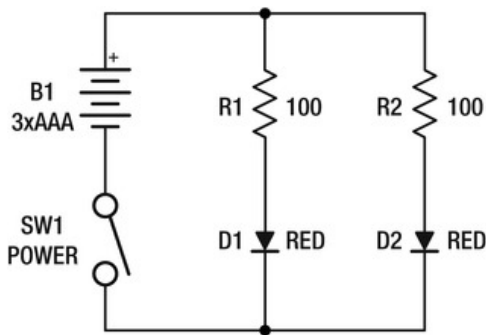

Figure 5-13. The traditional schematic diagram of the two-LED circuit. This diagram should convey the very basic information needed to build the circuit, as well as understand the important aspects of how the circuit is supposed to work, without going into much detail at all about the actual implementation or assembly of the components.

By now you should be able to look at the schematic and see the loop formed by the circuit. The only new twist is that there are *two* paths along which the electricity can flow, either through R1 and D1 (the top LED on the breadboard) or through R2 and D2 (the bottom LED, or the initials of a certain adorable robot from the movies).

The three AAA cells in the battery holder are shown as B1 in the diagram. The power switch, labeled SW1, is shown as a separate component to remind us that the circuit can easily be broken, halting the flow of electricity, which is something we want to happen from time to time. The connections between the two resistors and the two LEDs should be somewhat obvious. I'll discuss the details for the parallel and series connections momentarily.

Remember that an electronic schematic diagram is an abstract representation, boiled down to only the essential items involved and the relationships among them. As such, it doesn't need to resemble the final product, but it could. See Figure 5-14.

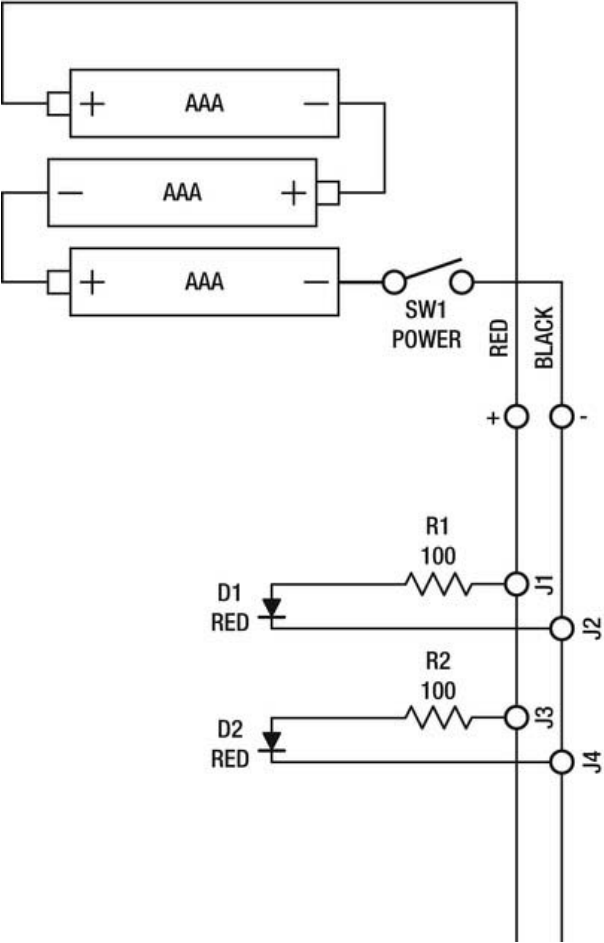

Figure 5-14. Another schematic diagram of the two-LED circuit, showing the approximate physical layout of the components on the solderless breadboard. This style of schematic is often used when describing how to actually build a circuit, showing the constraints of the actual, physical components and the connections between them. It conveys more specific information than the previous example in Figure 5-13.

Batteries in Series and Parallel

Let's look at the batteries first. Technically, as mentioned in Chapter 1, there is one *battery* in this circuit, and it happens to be composed of three *cells*. The term *battery* is very often used interchangeably with *cells*, and the distinction is minor. It's better to avoid confusion than it is to be exactly, precisely *correct*—usually.

We see three cells sitting side by side in both the schematic in Figure 5-14 and the actual battery holder shown in Figure 5-12. The cells are connected *in series*, meaning that one connects to another that connects to another, and so forth. They are like beads on a single wire. You should be able to trace the wiring (the solid lines) that connects the individual cells in the schematic.

Note the polarity of each of the cells within the battery. The positive terminal of the bottom-most cell is wired to the negative terminal of the center cell. The positive terminal of the center cell is connected to the negative terminal of the topmost cell.

The negative terminal of the bottom-most cell is connected to one side of an *SPST* (*single-pole, single-throw*) switch. The other side of the switch emerges from the battery holder's body as the black, or negative, lead from the battery pack. The positive terminal of the topmost cell connects directly to the red, or positive, lead coming out of the battery pack.

The switch could have just as easily been installed in the positive lead, and it would have worked exactly the same. The battery holder used in the photograph happens to switch the negative lead, as was revealed by examining the internal wiring using a multimeter as a continuity tester.

When the switch is *open* (i.e., in the Off position), the circle is broken and no electricity is going to flow. When the switch is *closed*, the circuit is complete and power is made available to the remainder of the LED circuit, assuming that it is wired up correctly.

The amount of *voltage* being supplied by the battery holder depends on the electrical characteristics of the individual cells. If alkaline batteries are used, each cell will provide 1.5V, assuming that the cells are relatively fresh. Rechargeable NiCd or NiMH cells will provide around 1.2V when fully charged.

When batteries like these are connected in series, the total voltage available is the sum of each of the cells. Just add all the voltages together. For example, using fresh alkaline batteries, the total voltage would be $3 \times 1.5V = 4.5V$. Rechargeable cells would provide $3 \times 1.2V = 3.6V$ when fully charged.

If the cells were wired *in parallel*, with all of the positive terminals being connected together and all of the negative terminals wired together, the total output voltage would only be 1.5V for alkaline cells. The total output *current*, however, would be triple the capacity of each individual cell. See Figure 5-15 for a comparison of series, parallel, and combination circuits using batteries.

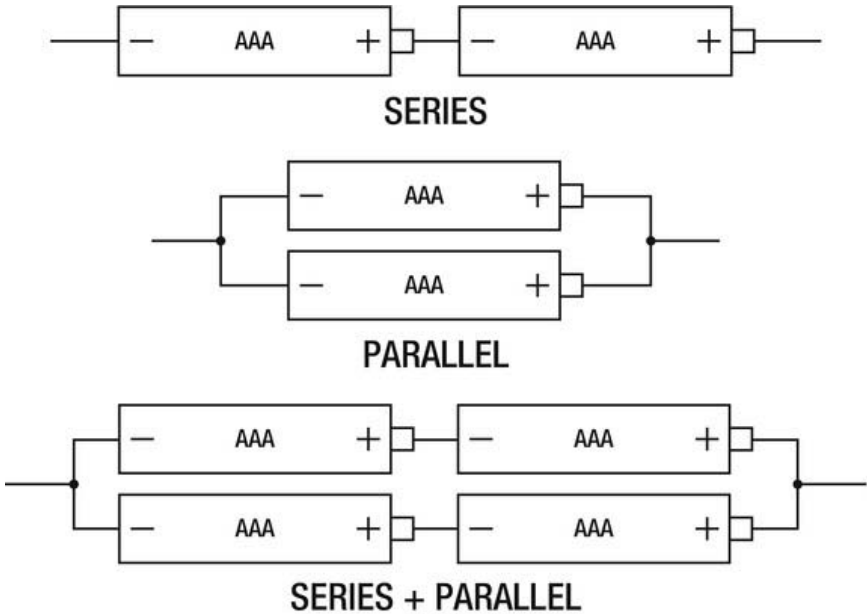

Figure 5-15. Different arrangements of the wiring of the batteries produce different results. The top two cells are arranged in series. Their respective voltages are added together. The center circuit consists of two cells arranged in parallel. This configuration doubles the current that can be delivered. The bottom drawing shows a combination of both series and parallel circuits, doubling both the voltage and the current.

When connected in series, the total current output is the same as the current capacity of each individual cell.

In summary, if you need more voltage, stack the cells end to end. If you need more current, stack them side by side. Even more complex arrangements are possible, using both parallel and series circuits to achieve the desired power output characteristics. This practice is very common in hobby model aircraft and battery-powered vehicles. A designation such as 3S2P means that there are two parallel circuits (2P) of three cells in series (3S).

Looking back at the circuit in Figures 5-13 and 5-14, we see that the “battery” used in this circuit consists of three cells in series. This means that if alkaline batteries of 1.5V each are used, the total voltage available to the circuit is 4.5V. If typical rechargeable cells (NiCd or NiMH) are used, we can expect 3.6V to flow through the circuit.

Switches in Series

The power switch, labeled SW1 in the schematic, is *in series* with the rest of the circuit. As mentioned in the previous section, when this switch is open, no current flows through the circuit at all. The switch is intentionally placed at this location in this circuit to act as a bottleneck. When the power switch is turned off, no power flows through the circuit. That seems like a good idea, considering the desired operational goal.

The schematic symbol for SW1 shows a pretty good likeness to the internal wiring of any simple SPST switch. There are two terminals, and a conductor that can be moved to either electrically connect them or electrically isolate them. As drawn, the switch is in the open position.

If we added another identical switch in series with the existing switch, what would happen? Take a look at Figure 5-16.

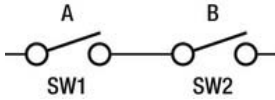

Figure 5-16. Two switches in series. Both switches must be closed for electricity to flow through this part of the circuit. If either switch is open, the circuit is broken and no current will flow.

Both switch A (SW1) and switch B (SW2) must be moved to the closed position for any electricity to flow through the circuit. If either switch is opened, then no current will flow. This is sometimes referred to as an *AND* circuit. Both A *and* B must be on for the circuit to operate.

A circuit just like this is often used in security systems. Switches are attached to doors and windows. All of the switches are wired in series, forming a large loop. The switches are all configured to be closed when the doors and windows are closed, and to open when doors or windows are opened.

If all the doors and windows are closed, then the loop of switches will allow the flow of electricity. Although it sounds exactly *backward*, when electricity is flowing in the circuit, this keeps the security alarm *turned off*. When any one of the switches is opened, the circuit is broken. The alarm then sounds.

Most real security systems are more complex than this, of course. The main advantage of this particular configuration is that it is easy to install and requires the least amount of wiring. The chief disadvantage is that when the alarm is triggered, you have no idea exactly *which switch* caused it.

Switches in Parallel

Just like with batteries, switches behave differently when configured in a different manner. Let's connect two switches *in parallel* this time and see what happens. See Figure 5-17.

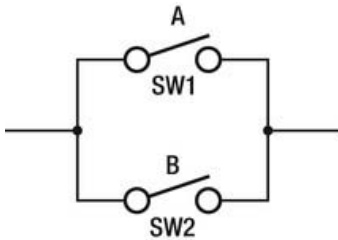

Figure 5-17. Two SPST switches in parallel. If either one of the switches is closed, then power can flow through this part of the circuit. Both switches must be opened to stop the flow of current.

The circuit in Figure 5-17 will conduct electricity if switch A (SW1) *or* switch B (SW2) are closed. To stop the flow of current, you have to open both switches. This can be used as a simple *OR* circuit. If switch A *or* switch B is closed, then power can flow through the circuit.

Looking back at the schematics in Figures 5-13 and 5-14, we see that SW1 is in series with the rest of the circuit. This makes it a very effective way to turn power on and off from a single location. Handy!

The Three-Way Switch

You might think that the circuit shown in Figure 5-17 could be used to turn lights on and off from two different locations. You would be partly correct. You could turn lights *on* from either switch location, since flipping either switch to On will cause current to flow and lights (or other appliances) to operate.

Unfortunately, you would not be able to turn *off* the light from either switch if the other switch were on. So this configuration is good for turning lights on but not off. A slightly more complex arrangement is required to do both.

We will need two switches, as before, but they will need to have a little more functionality to accomplish what we've set out to do. Instead of a switch that's either open or closed, we need a switch that alternates between two different routes, depending on how it is positioned. This type of switch is called a *double-throw* switch, as it connects a *common* terminal to either one of two different terminals. It can be *thrown* in two different directions. This should be much easier to understand when looking at a schematic symbol. See Figure 5-18.

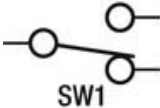

Figure 5-18. A single-pole, double-throw (SPDT) switch. The common terminal on the left side is connected to either the top or bottom terminal on the right. Variations of this type of switch have a neutral position in the middle. Push-button (i.e., momentary contact) versions of this switch will label the two right-side terminals as either “normally open” or “normally closed,” depending on the physical configuration of the switch.

Now comes the clever bit. We'll connect a pair of these switches together by tying the two non-common terminals on one switch to their counterparts on the other switch. This results in four possible combinations of switch positions (both down, one up, the other up, and both up). Two possibilities turn the light on, and the other two turn the light off. The important point is that the “on” or “off” state of the entire circuit can be changed from either location, independently of the state of the other switch. Problem solved! Again, this should be easier to see when presented as a diagram. See Figure 5-19.

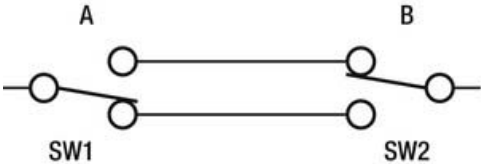

Figure 5-19. A three-way switch circuit built using two SPDT switches. Power is either carried by the upper wire or the lower wire, as long as both switches are in the same position. If not, then no power flows across this part of the circuit. As shown, the three-way switch is effectively off. Flip either switch to turn it on.

If you ask a real electrician how to wire a three-way switch, you'll get several answers, or more likely, you'll get, “It depends.” That's because *it really does* depend on the actual wiring situation. Sometimes the power is routed through one or the other of the two switches, and sometimes the power is routed through the load. Each of these scenarios requires a different routing of wires and connections.

You are strongly advised to consult a real electrician concerning wiring in your house, where your family, pets, and all your stuff live. Less-than-perfect wiring causes fires or electrocution, which are both very unpleasant ways to die.

■ **Caution** This book does *not* teach you how to wire electricity in your home. Consult a professional.

Resistors in Series

Just like batteries and switches, resistors perform different functions in a circuit depending on their configuration. Let's look at using resistors *in series* first, and then consider using them in parallel later. Both combinations have their uses, as you will see.

Let's look at just a small part of the schematic that we've been working with so far in this chapter. See Figure 5-20.

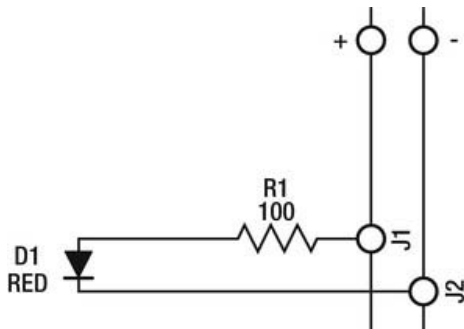

Figure 5-20. One part of the circuit showing an LED, a resistor, and the power rails from our solderless breadboard. The resistor and LED are connected in series. The battery and power switch are not shown.

LED Curiosities

D1 is an LED. It is a polarized component and will only work when installed in the proper orientation. The schematic indicates a red LED should be used, but feel free to use whatever color LED you like or happen to have available. The triangle shape of the schematic symbol helps remind us of the direction of *conventional current* through the device. The actual flow of electrons is the other way, but that's only because electrons are negatively charged particles and do everything backward. Apparently this was not well understood when electricity was first being tamed for our use.

LEDs are fascinating devices, emitting light in a wide range of colors, coming in an astounding array of shapes and sizes, and generally requiring very little power to operate. They are almost as easy to use as incandescent bulbs and are certainly more power efficient.

Being semiconductors, however (which leads to their being semimagical in their inner workings), LEDs generally only operate correctly within tightly bounded parameters. For example, a typical LED will only need between 2 and 3V to shine quite brightly. Incandescent lightbulbs, on the other hand, can operate from less than 1V to many hundreds of volts, depending on their construction and intended purpose.

While LEDs have a minimum *forward voltage* requirement that must be met for them to work at all, the brightness of an LED is determined solely by the amount of current flowing through it.

LEDs Have No Self-Control

In addition, LEDs have no internal, inherent mechanism to limit the amount of current flowing through them. Incandescent bulbs, when cold, have a low internal resistance, allowing much current to flow through them when connected to the right power supply. Remember that less resistance means more current can flow, and vice versa. This resistance almost instantly goes way up as the filament of the bulb glows white hot. The filament itself then becomes the limiting factor in how much current flows through the bulb, usually stabilizing at the proper power level.

LEDs have no such sense of self-control. They will conduct as much current through themselves as you are willing to provide, up to and beyond the point where the internal heat generated by the small amount of resistance they do possess causes them to literally burn up. In general, it's usually the tiny, almost microscopic internal bond wires that fizzle out, not the actual LED chip itself. However, dead is dead, and LEDs are generally considered to be “unrepairable” subassemblies. (Believe it or not, that's the correct technical term, even though it's not the correct English word—*irreparable* is the correct term when speaking of non-electrical things).

Care and Feeding of LEDs

The simplest possible solution to this ~~problem~~ opportunity for excellence is the use of a *current-limiting resistor* in series with the LED. Recall that a resistor will resist the flow of current in a circuit. The resistor used in this circuit, R1, is indicated to exhibit a resistance of 100Ω.

Let's say that D1, the red LED in our circuit, requires 2V in normal operation. This is pretty common for red LEDs. Generally speaking, the forward voltage requirement for LEDs goes up as you get farther up the color spectrum. Blue LEDs, for example, often require 3.0V to 3.6V to operate.

If we're using rechargeable cells in our prototype (and we really should be, you know), we can expect 3.6V to be made available to the resistor-plus-LED loop within our circuit. If 2V is needed for the LED, where are the rest of those volts going?

The answer is that they are being used to heat up the current-limiting resistor R1. Resistors turn current into heat. That's what they do. They do it, however, in a very precise and predictable way, which makes it easy for us to calculate how much current, voltage, and heat will be churning around in our circuits.

■ **Caution** Third-grade arithmetic ahead: Addition, subtraction, multiplication, and (shudder) division. You have been warned.

If we started with 3.6V, and two of those volts are being used by the LED, then our good friend Subtraction tells us that we've got 1.6V flowing through R1. For a thorough explanation of why this happens the way it does, feel free to look up Kirchhoff's Voltage Law. It basically says that all the voltages in a circuit end up being equal. The voltage across the resistor and LED will equal the battery voltage. The voltages within the LED-in-series-with-resistor circuit add up, just like battery voltages add up in series.

If we know the voltage across R1 (1.6V) and the resistance of R1 (100Ω), then we can use Ohm's Law to calculate the current flowing through R1. Reviewing what you learned in Chapter 3 about the predictable and inviolable relationships between voltage, resistance, and current, you can see that $I = E / R$ (i.e., current equals voltage divided by resistance), where I is the current in amps, E is the voltage in volts, and R is the resistance in ohms.

It's not that hard! It sounds much worse than it actually is. The answer is 0.016A, or 16mA (1.6V/100Ω). That's the teeny-tiny amount of current needed to light up a typical red LED. Most small LEDs can handle up to 25mA safely, and some can handle much more than that, especially if they are intended for illumination purposes.

One quick side trip to multiplication land and we'll know everything we need to know about R1 in this circuit. While the schematic specified the resistance of R1 as 100Ω (the primary characteristic or component *value*), nothing was said about the power-handling capability of this component.

Power is calculated as voltage multiplied by current. That's all there is to it. We know the voltage: 1.6V. We know the current: 16mA. We multiply them together to get 0.0256W (watts), or almost 26mW. Remember that you have to enter the current as 0.016 because the formula calls for the number of *amps*, not milliamps.

Not quite 26mA is not quite much of anything. You will not be able to tell that the resistor is shedding all those extra volts as heat with your fingertip. It might not even register with a sensitive thermometer. It's just a really tiny amount of power. A typical small resistor (a 1/4W resistor) will handle 250mW of power, which is almost ten times what is needed in this application.

■ **Tip** It's always a good idea to calculate the power requirements of your components, just so you're not *too* surprised when the magic smoke leaves the circuit, rendering it crispy and nonfunctional.

OK, we're back from the frightening land of multiplication. It wasn't *that* bad was it? The remainder of understanding resistors in series depends only upon the science of addition. Counting on your fingers will be good enough.

We can change the brightness of the LED by changing the amount of current flowing through it. We can change the amount of current flowing through the LED by either raising the supply voltage or by changing the resistance of R1. Since we can easily substitute any other value of resistor for the 100Ω resistor with which we began, this is easy to do. Just don't go *too low* in resistor value, as this will allow *too much* current to flow through the LED, possibly damaging it permanently.

Adding resistors in series adds their resistances together. For example, if you placed two 100Ω resistors end to end, the total resistance across them would be 200Ω. That's really all there is to it: $100\Omega + 100\Omega = 200\Omega$.

If you perform this experiment with the LED circuit we built on the breadboard, you can see that the LED will not shine as brightly as it did before. This is because the resistance has doubled, which means, all other factors remaining the same, that the current through the LED has been cut in half. Half the current results in half the brightness, since LEDs are controlled by the amount of current flowing through them.

What's interesting about this arrangement is that the power-handling capacity of the two resistors is *also* double what it was when only one resistor was in the circuit. This is because each resistor is now dissipating half the power when compared with the previous scenario. If two 1/4W resistors are used in series, they can together safely dissipate up to 1/2W of power, although pushing any component to 100 percent of its capacity is just asking for trouble, especially when heat is concerned.

By connecting resistors end to end, you add their resistances together, as well as their power-handling capabilities. By keeping a small variety of basic values on hand (e.g., 1 Ω , 10 Ω , 100 Ω , 1K Ω , 10K Ω , etc.), you can easily stack up the right combination needed for almost any electronic application. This is the method used in the very handy device known as a *decade resistor* or *decade box*, which has dials for each digit in the desired resistance, allowing you to dial up any value of resistor needed.

Extra credit: If you've followed along this far, consider researching voltage dividers built using only resistors.

Resistors in Parallel

What happens when resistors are connected side by side instead of end to end? That's where things get interesting, at least from a mathematical point of view.

An easy way to look at parallel resistors is to think about the amount of current flowing through each one, and then add them all up. See Figure 5-21.

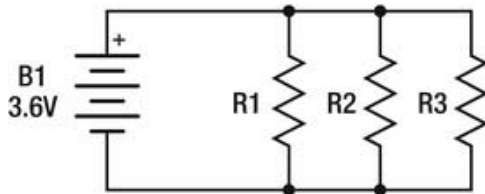

Figure 5-21. Parallel resistors each conduct a portion of the total current flow through the circuit. Each resistor allows a certain amount of current to flow. The sum of their currents can be calculated if their individual resistances are known.

Let's assume that R1, R2, and R3 have resistances of 100 Ω , 200 Ω , and 300 Ω , respectively. The total resistance of the circuit across the battery terminals is *not* 600 Ω , as would be the case if they were in series instead of parallel. The total resistance is less than 100 Ω , which is the least of the resistors. How can this be?

First, let's think in terms of how much current is flowing in each of the three parallel pathways within this circuit. If B1 is putting out 3.6V, and R1 is 100 Ω , then we know to use Ohm's Law to calculate the current, with $I = E / R$. In this case, $I = 3.6V / 100\Omega = 0.036A$, or 36mA. *In addition*, the path through R2 is drawing half that (because R2 is double the value of R1—get it?), or 18 mA. *In addition*, the final pathway is drawing one-third as much current as the first one, or 12 mA. Just to verify: $I = 3.6 / 300\Omega = 0.012A$, or 12mA. Everything checks out.

Now add all those currents together: 36mA + 18mA + 12mA = 66mA. That's the total current, using this method. Again, since we know both the voltage and the current, we can find the *effective* or *equivalent resistance* of all three resistors in parallel, as if they were one single resistor. Rearranging the formula for Ohm's Law, we find that $R = E / I$. In our case, $R = 3.6 / 0.066A = \sim 54.55\Omega$. See? Smaller than 100 Ω , somehow.

Thinking about the individual *currents* flowing through each resistor is the same as adding the current-supplying capacity of battery cells together when arrayed in parallel. Just add them together. However, we had to calculate each current separately and then add them together. There is a more direct way, depending upon how you look at things, but beware: it involves not only *fractions*, but *fractions upon fractions*. Oh, the horror.

■ **Note** Some people don't dig math. Weird, but true.

Here is the equation for calculating the total resistance (R_T) of three resistors in parallel (R_1 , R_2 , R_3):

$$R_T = \frac{1}{\left(\frac{1}{R_1}\right) + \left(\frac{1}{R_2}\right) + \left(\frac{1}{R_3}\right)}$$

The good thing about this equation is that you don't need to know what the supply voltage is to get the correct answer. All you need to know are the values of the resistors. If you need to use more resistors, just add more terms to the equation.

Calculating the value of parallel resistors occurs quite frequently when designing electronics. Some special cases are simple enough to do in your head. For example, if two identical-value resistors are placed in parallel, their combined resistance is half the value of each individual resistor. That is, if you placed two 100Ω ohm resistors in parallel, their effective resistance would be 50Ω. Similarly, if you have three identical resistors, the net resistance is one-third the value of each constituent resistor. Make sense? These are special cases of the general equation just shown.

This happens so much that an alternate notation method has been developed: $R_1 = R_1 | R_2 | R_3$. This is not often used for hobby electronics, however.

The power-handling ratings of resistors are added together, so if you have two 10W resistors in parallel, the net power-handling capacity is now 20W. At least that part was easy.

Capacitors in Series and Parallel

Capacitors are completely different from resistors. When calculating their values in series and in parallel, you have to use *exactly the opposite* methods. Isn't electronics interesting?

The values of capacitors *in parallel* are added together. This makes them much more like batteries in parallel than resistors. However, you still have to use the fractions-upon-fractions method to calculate the value of capacitors in series.

Again, some shortcuts are available. Two identical capacitors in series have *half* the capacitance of each individual capacitor, but *double* the working voltage, which is the maximum voltage they were designed to withstand before failing.

Inductors in Series and Parallel

It gets more interesting, believe it or not. Inductors act like resistors as far as adding their values together in series and taking the reciprocal of the sum of the reciprocals of their values in parallel, but *only* when the magnetic fields of all of the inductors involved do not interfere with each other. If the magnetic fields generated when current flows through the inductors overlap, then you have to factor in their *mutual inductance*, which starts to get complicated.

Extra credit: Figure out how all that works and let me know.

LEDs in Series and Parallel

You learned (or were reminded of) a few of the basic characteristics of LEDs in the previous section, although it was really to help illustrate the operation of resistors in series and parallel. A couple of major oversimplifications were introduced to help concentrate on the resistor. We'll address a couple of these issues here.

Lighting up a single LED using a battery and a fixed current-limiting resistor is fun, but it's pretty basic stuff. Lighting up a *lot* of LEDs is where it gets to be a *lot* of fun. To do so, you need to learn a little more about the weirdness that is *semiconductor*.

LEDs are diodes (*LED* stands for *light-emitting diode*, after all). Diodes are semiconductors and are made by elves in a hollow tree. Semiconductors do not have nice linear voltage-to-current curves.

For the purposes of simplicity, in the previous section, it was suggested that LEDs have a certain minimum voltage that they need to operate. This is called their *forward voltage*, and is sometimes referred to as their *voltage drop* within a circuit. So far, this is all true. You can find an LED's forward voltage specification in the data sheet published by the manufacturer.

What you'll find, when you look, is that every manufacturer only publishes a *range* of voltages, such as 1.8V–2.2V, giving a minimum and a maximum voltage. This is what they are contractually obligated to deliver in their product. Anything outside of this range is considered *defective*, or at least out of tolerance. You might get a good deal on “rejects” that fall outside these parameters but still light up quite nicely. Such is the provenance of many of the penny LEDs available from overseas. Yes, they exist. And yes, you get what you pay for.

There are two reasons why LED manufacturers are being so deliberately vague in their specifications. The first is that process variations are going to produce a certain randomness to these values. One batch might be identical to the next batch, but then the third batch might be all over the place. Such things happen.

The second reason is where the real weirdness begins. Forward voltage is not a fixed value in any given device, but instead increases as the current increases. Again, this increase is *nonlinear* and cannot be calculated with a simple formula.

The best way to demonstrate this to yourself is to connect an LED to a power source via a variable resistor, such as a potentiometer. For the protection of your LED, add a fixed resistor in series with the potentiometer so that you establish a maximum current level, even when the potentiometer is turned all the way up (i.e., has almost zero resistance).

Now apply power and adjust the potentiometer until the LED just barely lights up. Now measure the voltage across the terminals of the LED, using a voltmeter. It should be in the neighborhood of 2V–3V. For extra credit, measure the current flowing *through* the LED, using an ammeter. This measurement will most likely be less than 1mA.

Compare these readings to what you find when the LED is at full brightness. The forward voltage across the LED goes up as the current goes up. To map the nonlinearity of this function, you would need to record many readings of both voltage and current, and then plot them in a graph.

Just as you can wire resistors, capacitors, and inductors in series and in parallel, you can do the same with LEDs. As with resistors, the forward voltage of the LEDs are added together when arranged in a series circuit. This raises the minimum voltage required to light up a string of LEDs in series. This means that you can't light up ten LEDs in a single string using a 9V battery. You have to first overcome the minimum forward voltage just to get any current at all flowing. Then you have to up the current to get the desired brightness, which simultaneously raises the total forward voltage through the circuit. You still need a current-limiting resistor in this circuit—but only one is needed. You don't have to have one for each LED.

The amount of current flowing through the string of LEDs is determined by the supply voltage, the cumulative forward voltage of all the LEDs, and the resistance of the current-limiting resistor. The same

amount of current is flowing in every part of the circuit. If 25mA is being drawn from the power supply to light up your single string of LEDs, that means that each and every LED has 25mA of juice flowing through it—more than enough to light them up quite nicely.

If you have a 12V power supply (or a car battery), you could string up to five or maybe six red LEDs in series, with a small current-limiting resistor. That's because each red LED will typically have a forward voltage between 1.8V and 2.2V. Other colors higher up the rainbow might need more voltage per LED, meaning fewer can be lit at once using a single string of LEDs in series.

But don't fret. You can light up as many LEDs as you want by placing multiple strings of LEDs in parallel with each other. Each additional string of LEDs adds to the total current draw, so you will eventually find a limit along that dimension as well. For an example of a small LED array using both parallel and series circuits, see Figure 5-22. The schematic is shown in Figure 5-23.

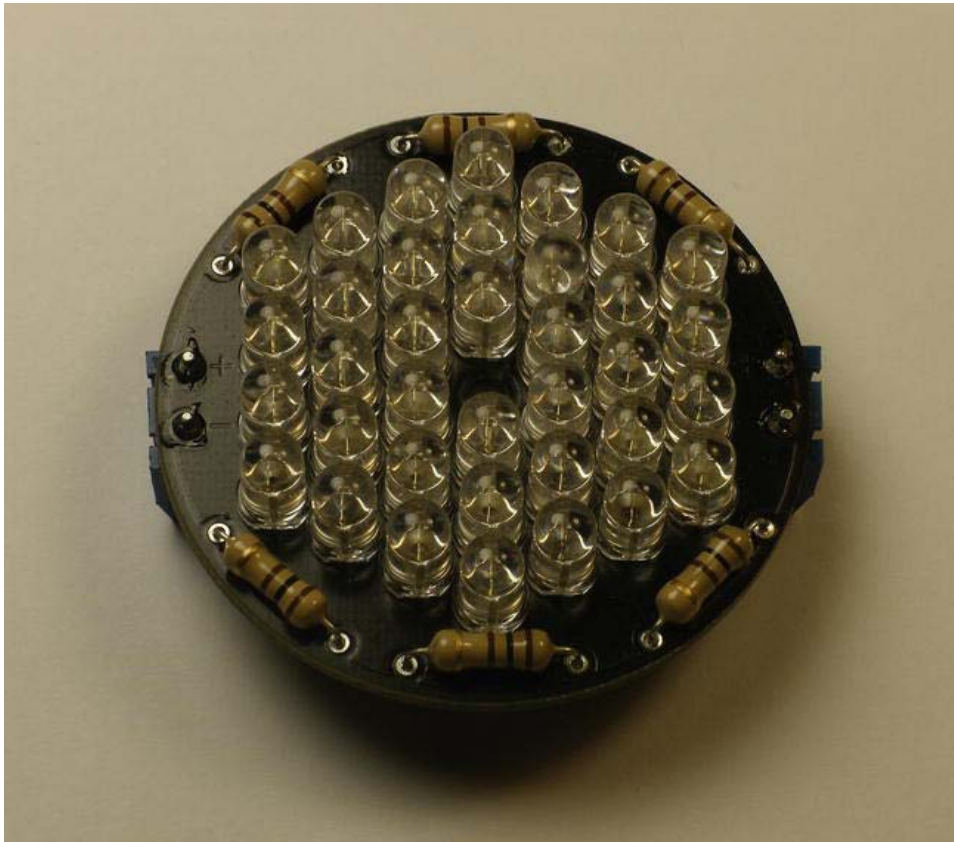

Figure 5-22. An array of six parallel strings of six infrared LEDs in series. These infrared spotlights are used for covert surveillance and security applications.

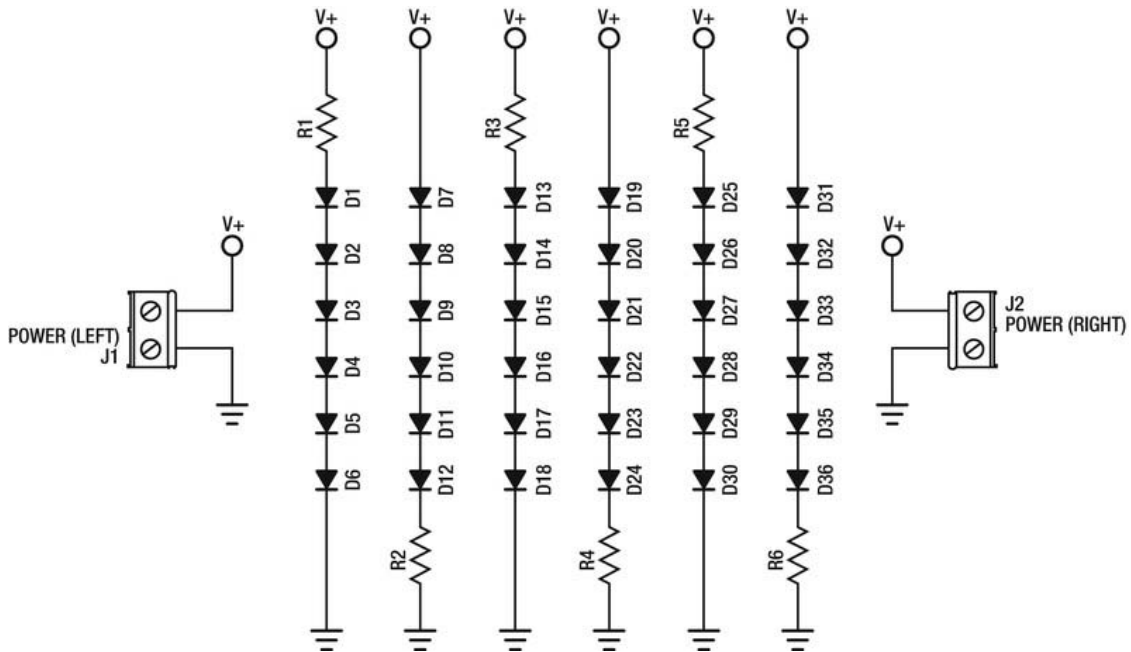

Figure 5-23. The schematic of the LED array, showing both parallel and series circuits. The circuit offers two power connectors to make it easy to wire multiple LED arrays using the same power supply.

Summary

Even if your workbench doesn't look as bad as the one presented at the beginning of this chapter (or even if it looks *worse*), hopefully you've learned a thing or two about the importance of they saying, "A place for everything and everything in its place." Since *you* get to decide where everything goes, you can either make it easy or hard on yourself as the years go by.

The workspace in this chapter extended to a total of 10 square feet. If this is what you have to work with, you can certainly set up a comfortable, safe, and productive area for your electronic projects. If you have even more space available (adding a shelf either above or below the desk is a great way to do this), then even better.

Hopefully some of the more detailed descriptions of how electronic components can be wired up have given you some ideas for projects of your own. The very best possible way to learn more about electronics is to think up some simple experiments and try to build them in your lab. Have a goal, take lots of notes, and have some fun—even your failures can be used as stepping stones to more ambitious and creative projects in the future.

Have a *lot* more room? Then perhaps you should be thinking about setting up a group lab or classroom. Chapter 6 will give you some helpful advice about what you are going to need to get started. See you there!

The Small Group Lab and Classroom

The first part of this book covered what you need to know to build your own personal electronics lab. Now it's time to share the love with your fellow electronics enthusiasts. Where to begin?

Like most important questions, the answer remains, "It depends." What resources are available to you and your group? How many folks will likely want to be working together, and for how long? How well do you really know these people? And these are just a few of the questions you're going to encounter along the way.

Take the time to understand exactly who "you" (plural; in Texas, *y'all*) are and what your requirements and goals could be. By doing so, you map out the future of your successful facility. Likewise, *not* planning ahead or making reasonable assumptions about your needs is simply an invitation to problems, problems, and more problems. Who wants *more* problems?

■ **Tip** If you fail to plan, you plan to fail.

Know Yourself

The ancient Greek maxim "know thyself" has as many definitions as it has authors, it seems. Plato indicated in several of his dialogues that Socrates would use this phrase to admonish his students to learn more about themselves and their own characters and capabilities before attempting to figure out the rest of the universe. Wise advice then and now.

As far as knowing yourself in relation to setting up a shared electronics lab, you should first think about what role *you* are going to play in this endeavor. Yes, *you*. Here are some of the major ones, and you might end up being all of them at some point.

Facilitator or Coordinator

In the role of the facilitator, you plan on providing an environment for others to use for their projects and explorations in electronics. You may or may not partake in these activities yourself, but have been tasked with (or volunteered for) the organization and coordination of the lab.

It's critically important to understand the needs of your intended ~~lab-monkeys~~ users. See the "Know Your Group" section later in the chapter for more information on this topic.

As the lab facilitator, lab workers will come to you with questions, requests, comments, and complaints. Be prepared to address their needs in a responsive and professional manner—even if they're just your cousin.

Your responsibilities will include

- Communicating the scope of the lab (i.e., deciding what *is* and what *is not* acceptable or expected)
- Publishing any important information or updates regarding location, available times, features, rules, and possibly ongoing projects
- Crafting policies involving safety, proper tool usage and training, and participant conduct
- Maintaining supplies of commonly used materials
- Inspecting and repairing tools as the need arises

To balance out your responsibilities, you should be granted adequate authority in the following areas:

- Characterizing the scope of the lab, based on present and anticipated future needs
- Enforcing the policies of the lab
- Budgetary discretion in acquiring, provisioning, and maintaining lab assets
- Granting or revoking access to the lab based on established parameters

If you're going to be the Keeper of the Lab, then you should have both a personal interest in keeping it in good shape as well as the wherewithal to decide how things should be done.

Good luck finding the right balance there.

Teacher or Presenter

Let's assume that your lab has already been set up (or can be set up in a jiffy), and your main goal is to present information or teach classes there. Again, it should be apparent that a good knowledge of your intended audience will play a vital part in your success. See the "Know Your Group" section for more information.

Once you understand the needs of your class and the goals of your presentation, the next step is to leverage the existing facilities to your best advantage. Will you need specialized presentation equipment or materials? If so, see what is already available, and then make a shopping list of everything else you will need. Examples include lighting, a projector, specialized power distribution, and test equipment.

Are you making an interactive presentation? If so, what materials will you need to provide for your students to be able to fully participate in your presentation?

What will be your optimum teacher-to-student ratio? If you have a simple message that's easily communicated and reinforced, a single speaker can effectively address a rather large crowd. Once you start adding layers of complexity to the subject matter, you're going to have to be prepared to backtrack and explain things in more detail from time to time. If you're leading a group through a technical exercise, it's often profitable to have assistants available to help just those individuals that need a little more help, without having to stop the class in its tracks. These assistants need to be up to speed on the subject matter as well as have good communication and troubleshooting skills.

Remember that students look to the teacher for leadership, not only as a subject-matter expert. Take the lead, set a good example, and share your enthusiasm for your topic with your students.

A successful teacher leads a class on a journey of discovery. Make sure you don't lose too many along the way.

Participant

Your goal as primarily a group lab participant is to make effective use of the facilities at hand, making the most of your time and energy. Having access to a well-stocked lab with a good array of tools can be a decided advantage for both your immediate project goals, and it can be an excellent opportunity to accelerate your knowledge of electronics and other mysterious arts.

Imagining yourself as an active participant is the best perspective when laying out the flow of your lab. Set up workstations that have almost everything you need, leaving room for the complex or specialized stuff elsewhere. There are more suggestions about specific workstation configurations in the “Workstations” section of this chapter.

While the active-participant model helps you squeeze out the maximum utilization of your lab, be sure to consider the sort-of-working-but-also-sort-of-goofing-off model. Not everyone wants to be working full-tilt all of the time. Leave room for a certain amount of idleness, contemplation, and whimsy. You might be surprised at the results.

Observer

You want to be in on the action, but not necessarily working on anything in particular. That's great! Don't underestimate the importance of the purely social aspects of technical gatherings.

Some people just like to hang out with other like-minded individuals. This is a good thing—when resources and circumstances allow it. Watching creative, talented, and driven folks working on projects with passion is very often the best kind of inspiration. Let your kids see you having fun and making cool stuff in your lab, and the next thing you know, they are going to want to be there whenever you are. Pretty soon, they are going to want to start working on projects of their own—and that is its own special reward.

Know Your Group

Now you know a little bit about who you are and what your expectations of your lab may be. Now it's time to get to know the group of people who will most benefit from access to the lab.

Identify the needs and requirements of your group by first identifying *precisely* who your intended audience is going to be. Knowing this one item, up front, before any big plans are laid, is the best way to ensure success down the road.

There are several broad categories for which you might need to prepare. The more you know about your particular group, the better. Let's start fairly close to home and expand outward.

Your Family

Once you've established your own electronics lab at home, it's great to be able to share some of the fun with those that are closest to you. This might be your children, parents, siblings, or extended family. A well-planned and well-maintained electronics lab is going to generate some interest, or at least some curiosity. Here's how you can carve out some room for them, while still being able to get things done yourself.

It's very natural to want to share your hobbies and interest with others, and a safe and well-stocked electronics lab is a great place to do so. This is an especially ripe opportunity for parents to pass on their knowledge, skills, values, and work ethic to the next generation.

The family lab can be a logical extension of the family home. Everything is shared, including responsibilities and privileges. In more agrarian societies, this is already well understood at an early age, where chores around the farm and in the fields and a respect for the tools being used help enhance a sense of group belonging and worth. Everyone has a stake in the prosperity of the family endeavor.

Do you want your kids to appreciate what you give them? Then give them chores before you give them presents. Let them clean up the lab, put away tools, inventory parts, and take out the trash before spoiling them with all the fun stuff you get to do in the lab. This will help foster a sense of ownership in the long-term success of the lab, whether you're there to supervise or not.

It bears repeating (from Chapter 4) that no unsupervised children, no matter how adorable, should be allowed in the lab. Would you allow unsupervised cooking in the kitchen? It's the same basic scenario. When everything goes well, everyone has a good time. It only takes a split-second distraction to go from a good time to a trip to the emergency room in either case. Have rules and enforce them, even if it's your elders that you are protecting by doing so.

Sometimes having a resource like a shared electronic laboratory is the first opportunity people have to assert some sort of control over their relationships. Use the opportunity to make friends with your relatives, while you still can.

Your Friends

Unlike your family, as the saying goes, you get to *pick* your friends. Now you have the opportunity to provide a cool place to hang out as well as build all manner of awesome gizmos. It's only natural to want to share some of the fun with your like-minded friends.

The basic framework of rules and accountability apply to the friendly lab as well as any other group endeavor. Let your friends know up front what your expectations of them are in regard to use of the lab. Can they use your tools? Can they store artwork-in-progress at your place? When is it cool to come over to tinker, and when is it not? These kinds of questions should be dealt with early in the game; otherwise, these issues can flare up and become trouble spots. There's no substitute for good communication.

Once you extend your laboratory's hospitality to those outside your immediate family, it's a good idea to clearly designate what is your personal property and what belongs to the lab and all its participants. This can be as simple as putting name tags on all your tools and marking shared resources appropriately.

This is where *trust* really factors into the success or failure of a group lab. Just like in math, you want to eliminate as many variables as possible to ensure that a good time is had by all, and to ensure the long-term safety and viability of the facility itself. Which of your friends do you *trust* in your lab? Think about these things at length before opening the doors to just anybody.

Coworkers and Fellow Students

So you've been tasked with organizing or supervising a lab for a school class or university department. You may or may not have any choice in who will be granted access, or even when they can avail themselves to the facilities.

The balance of responsibility and authority is crucial in this scenario, just like in most other situations in life. Hopefully you will be in a position to enforce whatever rules are already in place. Ideally, you will have some say in crafting new rules as they become necessary, or adjust existing rules when they need it. In either case, it's just not fair for someone to expect you to do a good job, yet not provide you the tools to get it done.

Positions like this become available from time to time in most schools. Sometimes there's an opportunity for a small paycheck, and other times all you are going to get are points with the administration. Hopefully, at least you will also enjoy lab privileges. That's got to be worth something, yes?

If you are helping to run an existing lab, there are probably others you can consult who have had this particular honor in the past. Try to find out who these folks might be and see if you can get any helpful advice from them about your lab and its care and feeding.

If you're starting from scratch, you will enjoy the double-edged sword of setting things up the way you want, as well as setting things up the way everyone else wants it. You *get* to establish whatever level of functionality you want, with the caveat that you then must maintain that level. It's a freedom, like most freedoms, that comes with a price.

Special-Interest Groups

Are you a member of club that has a special interest in electronics? Several popular interests, such as ham radio operators, remote-control model flyers or drivers, robot builders, and computer users, have a love-hate relationship with electronics. Having a dedicated electronics lab available to the membership is a great way to build up the love as well as work out the hate.

Given a highly specialized crowd, such as the members of a university or trade school, you might even find people organized into an electronics club, especially these days when almost every aspect of our lives is touched by this technology in one way or another.

The specialized nature of your group helps focus what areas of electronics are of most practical interest, at least from a lab point of view. This cascades into easier choices when it comes to stocking the lab with workstations, tools, and components.

The Dallas Personal Robotics Group (DPRG; see <http://dprg.org>), for example, had the use of an 1,800-square-foot warehouse for over six years, rent free, due to the generosity of one of the members, Mike Dodson of Modern Assemblies. Having access to an excellent industrial setting allowed the club members to dream of and then realize much more ambitious robot projects than could be attempted at home. After Mike's retirement, the DPRG went into a nomadic phase and finally spun off a dedicated workshop and meeting area, now called the Dallas Makerspace.

The General Public

A lot of people see the popularity of do-it-yourself (DIY) and *maker-movement* projects and envision themselves as entrepreneurs, seeing a need and being able to meet it. Unfortunately, most of these people are wrong.

Building a lab dedicated to public use sounds like a great and noble aim. The realities of such an undertaking, including the financial, logistical, and business related, are not to be underestimated. While it seems to work well in certain areas and at certain times, it's almost always the result of the right combination of people coming together at the right time.

Hackerspaces (a terribly unfortunately chosen label) are springing up all over the world. The term *hacker*, while understood within some technical communities to mean a person of respectable skills, has a decidedly *unrespectable* taint to it when viewed from the outside. To the vast majority of the English-speaking world, a hacker is a rogue computer jockey, a criminal intent on breaking and entering into computer systems for nefarious purposes.

The term *maker*, on the other hand, leaves a more positive first impression. The Dallas Makerspace members deliberately made this decision when naming themselves, while they were still just a subcommittee within the board of directors of the nomadic DPRG, looking for a new home. It was important to them to maintain the very positive image that the DPRG had established and built over its long history, while still looking to the future.

If you're going to set up a lab for use by the general public, whether you decide to call it a hackerspace, a makerspace, or something entirely different, you get to make almost *no* assumptions about the good intentions of your membership. It's a sad state of affairs, to be sure, but it seems to be the prevailing wisdom of the day.

Some popular and successful organizations—such as Noisebridge (www.noisebridge.net), in San Francisco, California, which was incorporated in the state as a “non-profit educational corporation for public benefit”—operate almost entirely on a “consensus basis,” sometimes known as “anarchic chaos.” Noisebridge’s overriding motto is “Be excellent to each other,” very often shortened to just “Be excellent.” Its very real success and sense of community among members is based on what seems to be a very local tolerance that is not to be found in many parts of the globe. If you ever get a chance, do stop by and prepare to be impressed. It’s an amazing place.

A good parallel would be to visit your local public library. In the areas that still maintain libraries (shockingly, they are on the decline), you will find a finely tuned machine that meshes well with the surrounding locality. Are there bars on the windows? If so, you’re going to need some bars on your windows. Are there metal detectors at the entrance? Oh, dear. Do you see any uniformed security forces present? These are not good signs.

Don’t be completely discouraged, however. Sometimes a community in decline needs a little boost of energy and an injection of *esprit de corps*. This can often be accomplished by introducing some new alternatives for people’s spare time. An ancient Muslim saying reads, “Trust in Allah, but tie your camel.”

A Shared Resource

Do you have a dedicated space available? If so, you are way ahead of the game. Finding a good location is half the battle. If your space is truly dedicated to your pursuits and activities (i.e., a private home, club, or makerspace), you have the advantage of being able to leave tools, components, and projects in place, returning to them (and finding them still there!) when the opportunity arises. “Truly dedicated” in this sense can be equated with having your own key to the door and reasonably free access. While a 24-hour facility sounds like a great idea, there are a lot of logistical problems associated, such as security, utility costs, scheduling, and parking, just to name a few.

If your space is not-so-dedicated, such as a school lab or friend’s garage, you can still make it a home away from home if you are able to arrange for secure storage of all your shiny toys. This could take the form of individual lockers or a storage closet.

No matter what the logistical arrangements, the main challenge to providing a versatile and effective setting for electronic and other kinds of tinkers is basically a social one. Once it’s more than just you, it can start to get complicated.

Luckily, there are some time-tested methods for making these types of things run smoothly.

Be a Hospitable Host

If you are taking the lead in arranging a shared work space, please remember that you are responsible for extending the appropriate hospitality to your present and future guests. This single factor will greatly determine the vibe, feeling, or ambiance of the facility, even more than having the latest and greatest tools and gizmos on hand.

This task may or may not fall entirely on your shoulders. Many hands make light work. If you are able to delegate some of the duties of a hospitable host to other members of your group, consider doing so.

Think of your task in the same light as planning a successful party, even if it’s one that you anticipate will last for days on end. These basic ideas are as old as civilized living. Think about fabulous parties or memorable events that you have been privileged to attend in the past, and then plan on taking it up a notch.

Try to anticipate the human needs of your attendees as well as their technological expectations. People have what seems like an endless list of requirements, some of which you can address, some not.

Make your location known. Make this information easy to find to those interested, and easy to update when the venue changes. A web site is trivial to set up these days, and even a post to a popular

forum will tend to be accessible via Internet search engines, in time. There's a new social media outlet popping up every third Tuesday, so avail yourself to what makes sense for your audience. Word of mouth only goes so far these days.

Once you've gone to the trouble of publishing your location, go the extra mile and put out some sort of actual sign or indicator that your arriving guests have found the right spot. If you have an identifiable logo or symbol associated with your group, be sure to proudly wave that flag. People don't like feeling lost, or unsure whether they're entering a welcoming space or about to trespass on private property.

Let everyone know when they are expected as well as when they are *not* expected. Post your regular meeting times, if you have them. Alternatively, make known the appropriate hours of operation. It's disappointing to be turned away at the door just because it's 1:00 a.m. on a school night.

When possible, welcome your guests. This makes a big impression on both newcomers as well as the regulars. Being part of a group is supposed to *enhance* a feeling of inclusiveness and belonging. We are social animals at heart, and even a simple hello is often the prelude to an interesting and productive time together.

Have rules. Make these rules known. A sign on the front door is not out of place, as long as it's not too negative or off-putting. Rules should *prevent* problems from occurring, and not be enacted as a spontaneous reaction when problems inevitably occur.

Ensure your guests' comfort when attending. Is there enough room for the largest (and the smallest) participant to safely enter and exit the facilities? Is there adequate lighting in the common areas, if they exist? Is there a place for everyone to sit? Who has dominion over the thermostat?

Do you plan on making refreshments available? Will this duty rotate among the membership? Keep track of such things, if only to keep from overextending yourself in all the myriad details of hosting a successful meeting. While massive banqueting and consumption of yummies make for a festive and enjoyable association, these activities are not always aligned with maintaining an effective laboratory. Separate the feeding trough from the work areas. Stay focused on what you're trying to accomplish here.

Will everyone have access to restrooms, and whose job is it to keep these areas tidy?

And the most important question of all: Who takes out the trash?

Be a Courteous Guest

Just as it's important to play the role of the hospitable host, it is likewise critical to be a courteous guest when visiting a facility, whether you are a paid-up member in good standing or an invited guest. Again, these guidelines will vary according to the intents and purposes of your lab, but the basics will always remain the same.

If possible, and when appropriate, let your host know if you are planning on attending. This won't apply in a causal, drop-in type of laboratory. Even so, by making your intentions of attending known ahead of time, you might influence (one way or the other) the attendance of other potential participants. Nothing succeeds like success. A well-attended party has a better potential for awesomeness than a sparsely peopled event.

Arrive on time or within the established time frames set forth by your host. Similarly, unless you have been granted special access, plan on leaving at a reasonable time as well. Benjamin Franklin wrote in his *Poor Richard's Almanack* (1736) that "Fish & Visitors stink in 3 days." Don't be a stinker.

Try to contribute something. Don't show up empty-handed, expecting to be fed, entertained, and enlightened.

Workstations

Now it's time to talk about your workstations. Even if it's just you in the lab, having a separate workstation for each type of activity is a great idea. For example, you might have one workstation set up for programming a computer, another for soldering electronics, and another for working with power tools, such as a drill press or a saw.

Workstations dedicated to a particular task should have everything within easy reach, including tooling, supplies, power, and lighting. Don't waste time by forcing people to wander around the lab looking for the right drill bit or magnifying glass. Keep everything close so you can find what you need, when you need it.

Having a place for everything ahead of time is the best way to follow the wise adage, "A place for everything and everything in its place." You get to decide where everything lives. It doesn't hurt to go ahead and label everything conspicuously so that others can find their way around the lab.

If you have several people wanting to work on the same kinds of projects at the same time, you're going to need multiple, nearly identical workstations. The exact number depends on your available space and the number of people you expect to want to participate simultaneously, as well as your budget.

Most indoor-oriented work can often be performed at a work table. Exceptions include giant-scale mechatronics, pyrotechnics, and underwater robotics. Some of their constituent bits and pieces, however, can be crafted on an adequately prepared work table.

Make sure each work area has plenty of power outlets available. You're almost guaranteed to run short at some point. Take care not to overload your circuits, however. If you anticipate needing a lot more power than is presently provisioned, you're going to have to consider the real possibility of having your facility expanded by qualified, *licensed* professionals. These requirements will vary from one location to the next. Check with your local building codes to be sure.

As repeated often in previous chapters, you can never have *too much* lighting available, especially for the more detail-oriented chores. Typical indoor room lighting is just about adequate for finding your way out of the room, and that's about all. You'll need area lighting for each workstation, and possible additional task lighting, depending on your particular requirements.

Providing network access to each workstation can be challenging. Wireless networking is a good way to accommodate a relatively small number of users at once. More than a handful of computers trying to access the Internet at the same time can bring many wireless routers to a slow crawl. Dedicated high-speed Ethernet connectivity is more expensive and takes more effort to deploy, but offers much greater bandwidth to your lab-folk.

If you're especially cramped (or *dimensionally constrained*) in your lab, you'll need to get inventive. For example, a table placed in the center of the room can be approached from multiple sides. There's no reason all the workbenches have to be pushed up against a wall, allowing access from only a single side. Get creative!

Safety Planning

While it's tempting to fill up all the available space in a lab with workstations, especially when the budget permits it, do try to leave a bit of common area here and there. You always want to be able to walk *away* from a workstation with the same (or sometimes even more) rapidity you approached it with. Fire is an excellent example of such a motivator.

■ **Tip** Keep a properly selected and maintained fire extinguisher at each workstation, if possible.

Post emergency procedures prominently, where everyone, including visitors, can see. Have an evacuation plan, complete with map and “You are here” indicator posted at each workstation. Hopefully you will never need it.

Presentations

Are you excited about your latest project? Have you just learned a great new skill? Setting up your lab for group presentations is an excellent way to communicate these ideas to your friends, family, and coworkers.

Make your ~~victims~~ guests comfortable. Have adequate seating for everyone, with plenty of room between the rows (if you have more than one row of chairs). Ensure that everyone has a good view of what you intend to present.

Will the attendees be expected to take notes? Then perhaps you should set up tables where they can comfortably jot down some of the more spectacular aspects of your presentation. If you will be providing a handout or other documentation packages, make sure you have enough for the anticipated demand. Will you be entertaining questions or comments either during the presentation or afterward? Then make sure that not only can your audience see *you*, but that *you* can see *them*.

If you’re going to be using some sort of projector for your presentation, by all means set aside some time to get to know the equipment ahead of time. Nothing ever seems to work just exactly as you imagined that it should. This seems to be an invariant law of presentation physics. No one is really sure why.

Your audience’s time is just as valuable as your own. In fact, if there are only two people attending, then their collective time is worth approximately *twice* as much as yours. Think about it. Have all your ducks in a row, so to speak. Wasting time figuring out which cable goes where is not a good use of your time together.

Summary

Wow! You can really go crazy setting up a shared electronics lab, can’t you?

Before you even flip on the light in your shiny new group lab, you should already have an insightful idea of who is going to be using it and why. You should also have some honest expectations of what your own expectations are going to be, and how you would like to interact with both the lab itself and its population.

The details, of course, are always going to be specific to your particular situation. Be on guard, however, for the future. It’s going to sneak up on you, someday. Not too long ago, for example, it took a fairly hefty desk to keep a modern personal computer up off the floor. That kind of computing power now fits in a pocket. Think of what better uses you could dream up for that space these days!

That kind of forward thinking is exactly what turns the dreams of today into the reality of tomorrow. It’s forward-thinking people like you, dear reader, that help map out those realities. Take the opportunity you have right now to spend some quality time daydreaming about how things *could* be. Then take those steps necessary to make it happen. Your family, your society, and your world expect great things from you. You can do it!

Getting Started with Tool Building

Once you've become comfortable in your lab and have had time to play with a few circuits, you might start to notice that some of the "tools" you've been using are just simple electronic circuits themselves. Good examples are power supplies and meters. These are great tool-building projects because you can see useful results early.

Let's take a look at building a couple of simple electronic tools that might be of use in your lab. Hopefully you will develop a better understanding of how these tools work. Ideally, you will progress from the basic question of "Does it work?" to the more involved questions of "How well does it work and what can I do to improve it?"

Please bear in mind that these exercises, while hopefully useful, are to illustrate what needs to go into the building of practical, reliable tools. At every stage you should be thinking about what design choices you have and which choices will enhance the usefulness of your tool-building process.

A Very Simple Power Supply

Almost all electronic projects need electricity to work. Having a good, dependable power supply at your disposal on your bench will get you started faster on new projects. You won't have to worry about dead batteries and flaky power adapters. See Figure A-1.



Figure A-1. A professional bench power supply. This device allows both the voltage and the maximum current to be adjusted. It provides two dedicated meters to show how much power is flowing: one for voltage and the other for current. It also provides a modular set of plugs (banana plugs) for easily connecting and disconnecting power leads.

A bench power supply such as the one shown in Figure A-1 has many features and includes extra circuitry to make it safe and easy to use. It will also set you back a good chunk of change (i.e., cost money). We're going to build something a bit simpler to start. Feel free to add more bells and whistles as your needs arise.

■ **Caution** Anything plugged into the wall has the potential to shock, burn, or kill you. Do not defeat their safety features!

An Easy 2.5 Watts

You probably have a spare USB charger lying around somewhere. If you don't already, you more than likely will at some point in the near future, as these are becoming more common with smaller electronic devices. If not, you can obtain one relatively cheaply if you do some smart shopping. The USB charger shown in Figure A-2 was obtained from overseas via eBay for less than \$1. You will also need a USB cable about 3 or 4 feet long. Again, don't spend a lot of money on a new cable. If you don't already have one floating around in a drawer somewhere, you probably know someone that does.



Figure A-2. A USB charger that plugs into the wall and provides a regulated +5V supply. This plug is intended for US wiring, but will operate from 110AC to 240VAC at 50 or 60Hz, which pretty much covers the whole world, if you have the right adapter plug.

It doesn't matter what type of USB cable you find, because we're going to cut off the smaller end and use the bare wires inside the cable. It just has to have the USB A-style plug shown on the left side of Figure A-2. The plug will fit into the socket of the charger. You do not need to open or modify the USB charger at all, and you are seriously advised not to do so for any reason.

Let's take a closer look at the label on the charger to find out exactly what it's supposed to be doing for us. See Figure A-3.



Figure A-3. The label of the USB charger tells us that it accepts anything from 110VAC to 240VAC at either 50Hz or 60Hz. This wide range of input power allows the same internal electronic design to be used worldwide. Only the prongs that plug into the wall vary from location to location. The label also tells us that the USB charger will output +5V at up to 500mA. That's 2.5W!

The “OUTPUT: 5.0V --- 500mA” marking tells us what we need to know about the flavor of the power coming out of the adapter. The “5.0V” is the measure of the voltage. This is a very useful voltage level for small projects. Many digital chips require a 5V supply, although 3.3V is also becoming quite popular.

The --- symbol represents *direct current (DC)* voltage. The symbol for *AC (alternating current)* voltage is the tilde, or wavy line symbol ~. The “500mA” is the maximum current that can be supplied by this charger (500 milliamps, or 0.5A), although you are cautioned not to expect a low-cost item such as this one to produce 100 percent of its rated power 100 percent of the time.

While this USB charger will most likely work for our intended purposes, it's best to keep those expectations in check. Note that “Model:” is misspelled (“Mode:”); and also note the absence of the magic letters *USB* or the USB logo. Also, there is a complete lack of any safety certifications present on this humble device, as befits its cheap, economically optimized provenance. Compare this with the veritable constellation of safety certifications on the name-brand laptop charger shown in Figure A-4.



Figure A-4. A name-brand laptop charger with several international safety certifications. Every one of these certifications costs money to obtain, and shows that the device was demonstrated to be safe for use in a typical home or business application.

Next we adapt the USB cable to our needs. In the words of the Red Queen, “Off with his head!”

■ **Caution** Make sure the USB charger is not plugged into the wall or a power strip when making modifications to the cable.

First, plug the USB cable into the USB charger. Now cut off the *other* end of the cable. See Figure A-5.



Figure A-5. Cut off the device end of the USB cable. If you cut off the wrong end, you're not going to be able to plug it back into the charger, at least not without a considerable amount of effort. To ensure you cut the correct end, plug the host end of the cable into the USB charger before snipping, and then cut off the other end.

Now carefully strip off about an inch of the cable's insulating jacket. Do your best to not nick the insulation on the wires inside. Within the jacket you should find four wires. Two of these wires carry the +5V and ground from the power supply. The other two wires carry the data on the USB connection. Since we're only interested in the power, we can ignore the other two wires for now. See Figure A-6.

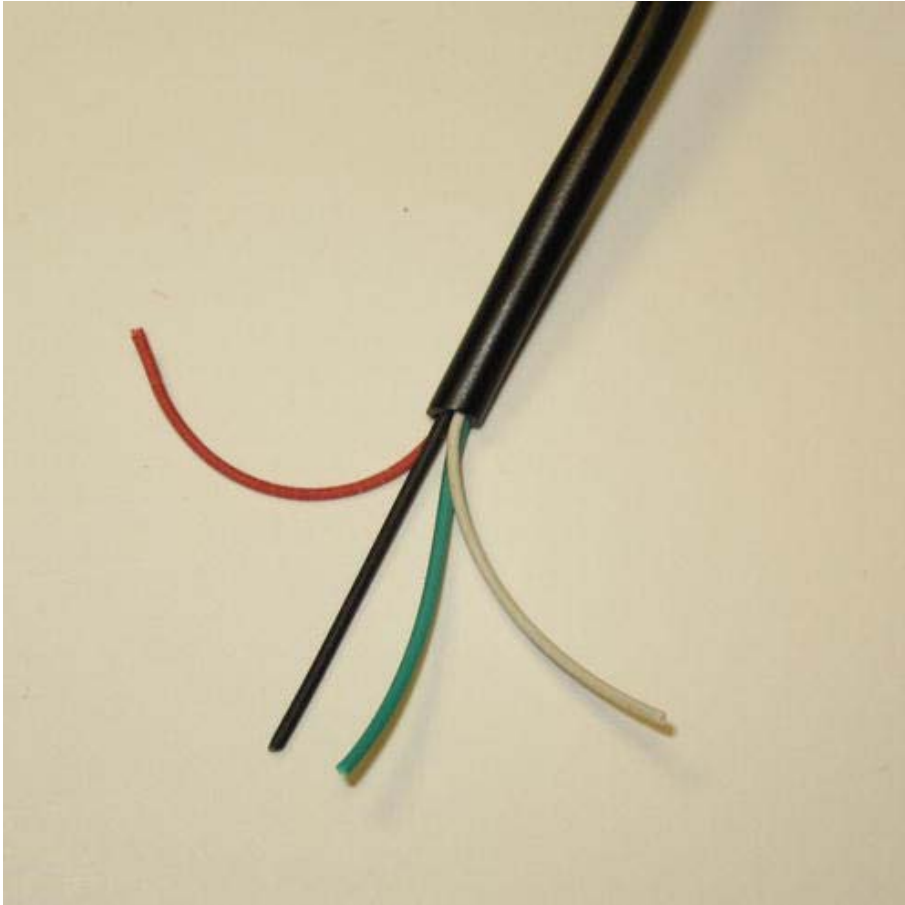

Figure A-6. The four internal wires within the USB cable. From left to right they are red (VBUS or +5V), black (ground), green (USB D+), and white (USB D-). Use the red and black wires to pull a regulated +5V from the charger.

The USB standard specifies every little detail about how to build and mark USB cables, even down to the colors of the internal wires in the cable that you're not ever supposed to see! That's dedication.

■ **Note** Apple violates the USB standard by not having a raised USB symbol molded into its cables.

However, sometimes cable manufacturers fudge a bit and use whatever four-conductor cable they happen to have lying around. A very common substitute cable uses red, blue, yellow, and brown wires internally. See Table A-1 for a list of which wires go where.

Table A-1. Standard USB Wire Colors and Their Functions, Along with Popular Alternate Colors

Function	Pin Number	Standard USB Color	Alternate Color
VBUS (+5V)	1	Red	Red
D- 2		White	Blue
D+ 3		Green	Yellow
GND 4		Black	Brown

Now is the time to verify the wiring before we get much further. Even if your cable has the official wire colors within the insulating jacket, you are strongly advised to double-check both the voltage and the polarity coming out of the charger before connecting it to your tender, sensitive circuits. Minimize your assumptions about the compliance of others. Testing proves testing works!

Strip about 1/4 inch of the insulation from the ends of the red and black wires. Get out your meter and set it up to read voltage at or above the 5V range. If your fancy meter has autoranging, then just set it to read DC voltage. Plug the USB cable into the charger, if it's not already installed. Make sure the red and black wires are not touching, and then plug the charger into the wall or a convenient power strip.

Now measure the voltage between the red and black wires. Hopefully you should see a reading at or near 5.0V. The USB standard specifies a tolerance of ± 10 percent, so anything between 4.5V and 5.5V is considered OK. See Figure A-7.



Figure A-7. Measure the voltage coming from the USB charger before connecting it to any of your circuits. This one reads 5V on the dot! This is a much safer method than trial by fire (i.e., plugging it into your circuit and looking for a fire).

Now that you've confirmed that the red and black wires do indeed carry the regulated +5V from the USB charger, you can clip off the unused green and white wires. At this point you can either use the bare, stripped wires of the USB cable or solder on a more robust connector. Since this power supply is destined to be used with a solderless breadboard, a small, two-pin connector with the appropriate spacing will be attached. See Figure A-8.

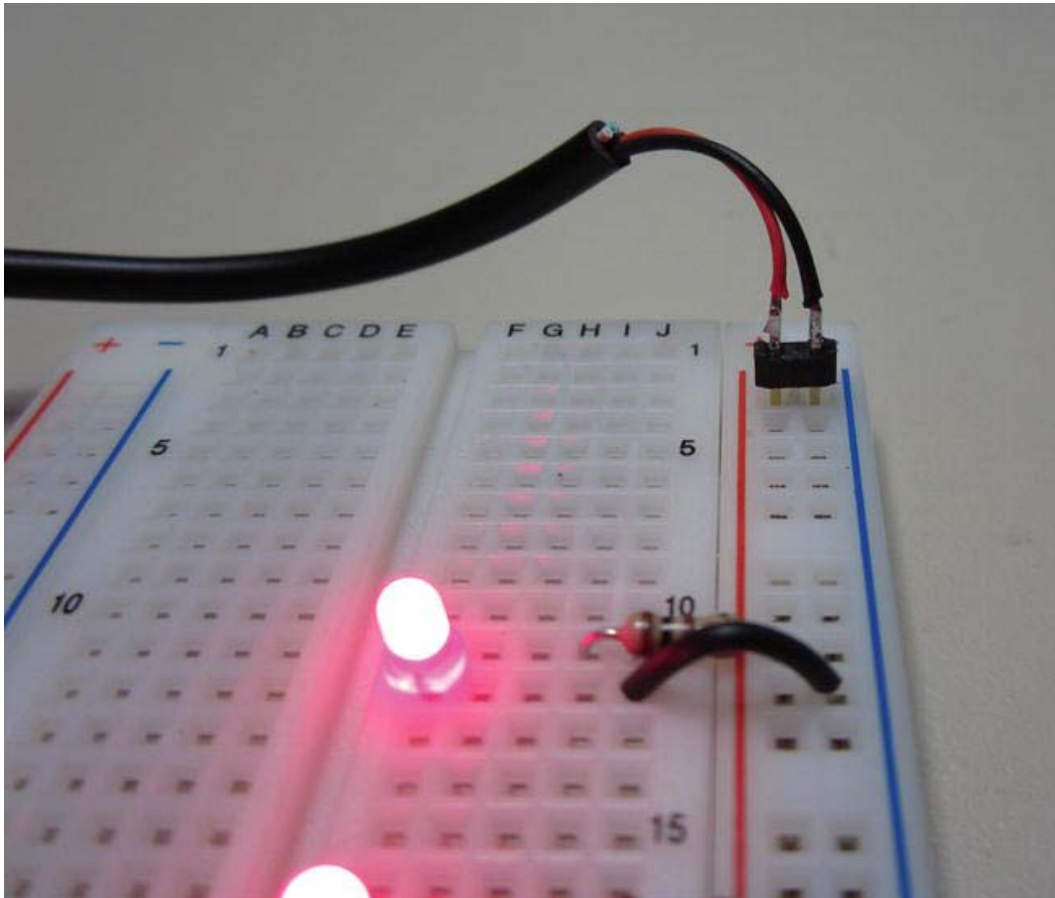

Figure A-8. A gold-plated pin connector is soldered to the modified USB cable. The red and black insulation is left visible to be a polarity indicator when installing the cable to the solderless breadboard. Another happy LED!

Adding Features

This power supply works just fine for most projects. If your requirements are, “Translate AC power from the wall into regulated DC power I can use for small projects, without spending a lot of money,” then this contraption fits the bill precisely.

You can see for yourself in Figure A-8 that it does indeed work as advertised. Looking back at Figure A-7, you can see that the charger itself has a power-on indicator LED built into the housing. What it doesn’t have is a power control or a switch. The power to the circuit is controlled by the switch on the power strip. This works just fine as long as you don’t mind turning on and off everything else that happens to be plugged into the same power strip.

Various Indicators

Not all USB chargers have a power indicator, however. Some have both a power indicator LED as well as a *charge status indicator*, which can tell you at a glance if your USB device is fully charged or still charging. A charge status indicator is usually implemented by measuring the amount of current being drawn from the supply. If more than a preset current is flowing, the power supply assumes a battery is still being charged. When that current drops below a certain level, it assumes that the battery has been completely (or maybe just mostly) charged. Some chargers use a red or orange LED to indicate charging, and a green or blue LED to show that the battery is finished charging. Again, this type of charge status display is provided to give the user a quick status update with a single glance. You don't need to consult the product manual to interpret the status code, if you can remember that red means "charging" and green means "charged."

Let's rearrange some of the parts on the solderless breadboard to make room for some new features. See Figure A-9.

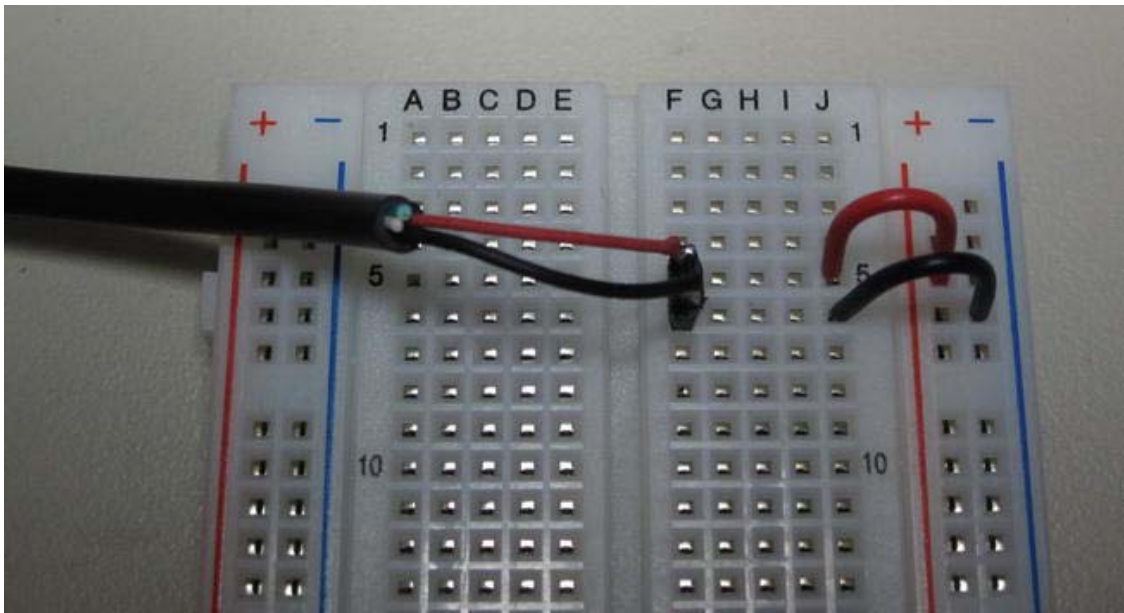

Figure A-9. The regulated power coming from the USB charger is no longer directly connected to the breadboard's power rails. Instead, it is routed to some internal tie points and then connected to the power rails via two short jumpers.

Power-On Indicator

First, we add a local power-on indicator by reinstalling the LED and current-limiting resistor used in the previous experiments. While this duplicates the function of any LEDs that might be present on the USB charger itself, it brings the indicator closer to the area of interest, which in this case is the circuitry onboard the solderless breadboard.

The anode of the LED goes into tie point F-3, with the cathode being installed at tie point F-4. The current-limiting resistor spans the gap between tie point I-3 and the right-hand positive (red) power rail. A short jumper connects tie point J-4 and the right-hand negative power rail. See Figure A-10.

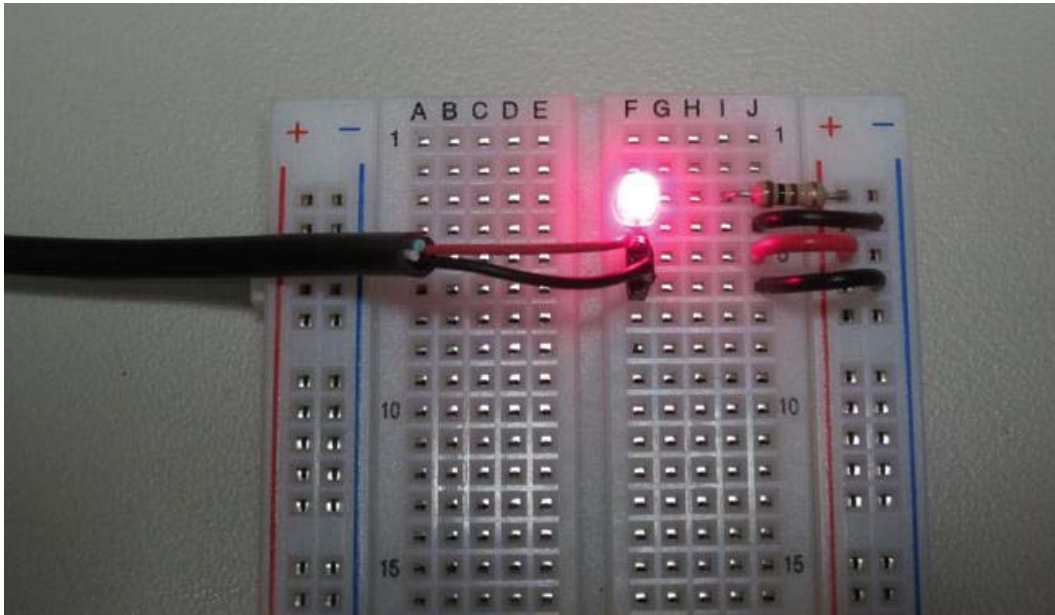

Figure A-10. Add an LED and a current-limiting resistor across the power rails of the solderless breadboard to give an at-a-glance power indicator, right where the action is taking place.

Now we have a good power-on indicator, right where we need it. It may or may not be redundant, depending on the features of your USB charger. This type of indicator is digital in the sense that it tells us that the circuit is either on or off, without giving us a lot of precise information about anything in between. For a lot of applications, however, this is more than enough information.

Power Supply Voltage

What if you *did* either want or need more precise information about the power supply? One method would be to permanently connect your multimeter to the circuit so that you can see how many volts are being delivered. That method assumes that you're not going to need your multimeter for anything else, ever.

A practical variation of that method, however, is to provide convenient *test points* in your circuit so that you can quickly and easily take a voltage reading when the need arises. Be sure to position the test points so that they are easy to access. Having a nice, big, readable label wouldn't hurt, either. Also, try to arrange things so that it's not likely that contact with a metal object, such as a tool or your wristwatch, will accidentally short out the power supply by touching both test points at the same time. Even simple "features" get complicated quickly, it seems!

If you want an accurate (and permanent) voltage reading on your circuit, consider adding a voltmeter. Small panel meters are relatively inexpensive and reasonably accurate. A DC voltmeter has two leads, positive and negative, that are attached across the voltage to be measured. See Figure A-11.

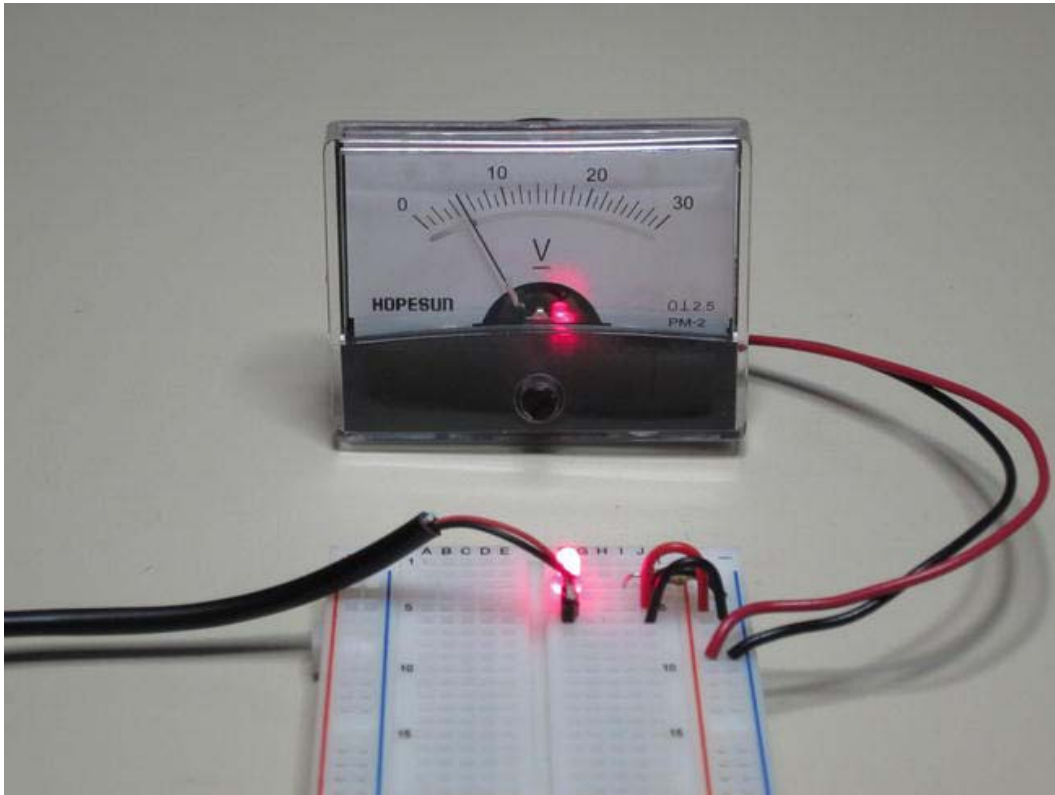

Figure A-11. A DC voltmeter is attached to the circuit to accurately measure the supply voltage. The V on the meter's legend stands for voltage. The underline beneath the V indicates that it is designed to measure DC voltages, as opposed to AC voltages.

The panel meter shown in Figure A-11 has a range of 0–30VDC. That's a bit more than we need, since our little power supply is only supposed to produce 5.0VDC \pm 10 percent. Since the meter's range does not accurately match the expected range of supply voltages, we lose a bit of precision when attempting to read the display. All the action is crowded together on the left side of the meter.

It might seem that a 0–5VDC meter would be preferable, but that would not allow for any overvoltage conditions at all. Remember, the USB standard allows for up to 5.5VDC to be delivered over the cable. A 0–6VDC meter, if available, would be more suitable. The meter introduced in Figure A-11, however, would be perfect when used with the laptop supply shown in Figure A-4, because its output voltage is 19.0V. That leaves a bit of room for overvoltage conditions and gives a wide enough swing of the needle to produce fine detail.

Power Supply Current

Measuring the *voltage* at any point in a circuit is easy. Just put a voltmeter between two points and voilà! In our previous example, we measured the VBUS power supply voltage with reference to GND, the ground potential of the circuit. Many voltage measurements are made with respect to ground.

To measure the current flowing through a circuit, we have two options. The first option is the most direct route. Install an ammeter (a meter that measures *amps* of current) inline with the circuit you want to measure. This requires that you *break* the circuit to make room for the meter. Once installed, the current flowing in the circuit actually flows through the ammeter as well.

The second option involves using a bit of trickery and some math. Instead of installing an ammeter directly inline with the current flow to be measured, we install a resistor of known resistance and measure the *voltage* that develops across the resistor.

Since we know that the values of volts, ohms, and amps are always related in any circuit, we can use Ohm's Law to determine how much current is flowing through a circuit by measuring the voltage across a known resistance.

To make things very easy, let's use a 1 Ω resistor in series with the power supply, inserted in the circuit between where the positive lead of the power supply arrives at the circuit and where it is connected to the rest of the circuitry.

Unlike our previous use of Ohm's Law to calculate the missing value based on two known values, we only use *one* known value (the value of the resistor, called a *shunt resistor* when used in this manner). This one known value (resistance) then establishes the relationship between the two other values, voltage and current. As the current increases in the circuit, so does the voltage across the resistor. The two values will mirror each other—as one increases or decreases, the other will follow.

Since we used a 1 Ω resistor in the circuit, this sets the relationship between current through the circuit and voltage across the resistor at a 1:1 ratio. For every ampere of current through the circuit, for example, 1V will be measured across the resistor.

Our power supply is only supposed to be able to deliver 0.5A of current, maximum, so we'll be dealing with voltages of less than 0.5V, unless something terribly unexpected happens.

Again, we could permanently attach a multimeter across the leads of a 1 Ω resistor inserted into the circuit, or we could attach a voltmeter that is sensitive enough to give accurately readable information in the range we need. The 0–30VDC meter used before is much too large in range to do us any good here. We might see a tiny wiggle in the needle, but that's all.

Instead, we'll use a different kind of meter entirely. A digital voltmeter contains its own dedicated measurement circuitry and a numeric display to indicate the voltage reading. It also requires its own separate power supply. See Figure A-12.

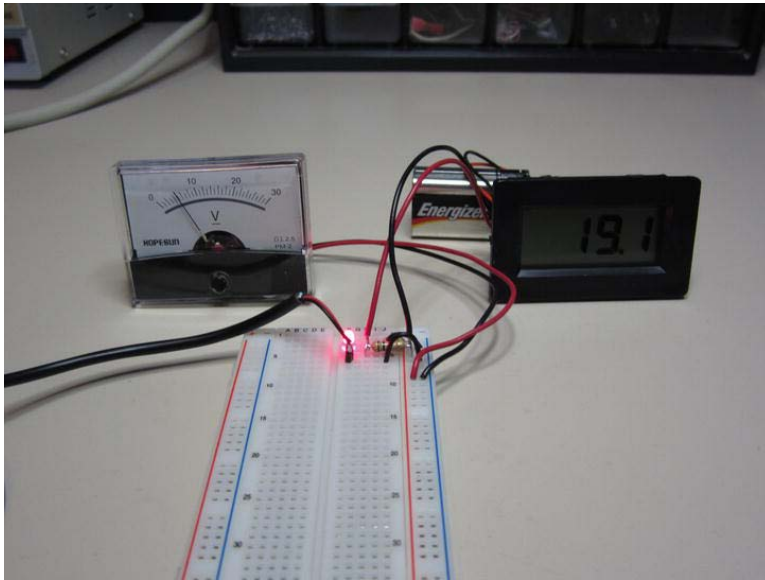

Figure A-12. A digital voltage meter is used to read the voltage across the shunt resistor installed in the circuit. Because the shunt resistor has a 1.0Ω value, Ohm's Law dictates that the reading in millivolts on the digital meter correspond exactly to the number of milliamps flowing through the circuit. Math is useful, sometimes.

The jumper wire connecting the incoming power supply directly to the power rail has been replaced with a 1Ω resistor. Leads from both ends of the resistor have been connected to the input terminals of the digital voltage meter on the right. The digital meter, unlike the analog meter on the left, requires an independent power supply to operate, in this case a 9V battery.

So now we've added some features to our simple power supply, including a power-on indicator, a supply voltage reading, and a supply current reading.

These are very useful features to have on any power supply. However, at this point in the prototyping stage, we've just barely covered what the added circuitry is supposed to do. Packaging all this up into an easy-to-use and reliable device takes as much if not more thought and effort.

First, you have to rebuild this entire circuit in a more permanent fashion. Next, you will have to wedge all that clever gadgetry into some sort of enclosure to protect the delicate bits while still permitting access to the inputs, outputs, and controls, if any. Then you get to label everything so that you can remember how to use it in the future.

Summary

So now you just might be developing a certain respect for how much work goes into building even the simplest tools—tools that are useful, accurate, reliable, and an asset to your toolbox. Remember, every tool on your workbench has to earn its place there. This applies to tools you design and build yourself, as well.

Good luck with your tool-building projects. Sometimes it's just as much fun to work on your tools as it is to work *with* your tools.

Index

■ A

Active electrical and electronic components

- batteries, 81
- diodes, 82–83
- integrated circuits, 84
- LEDs, 83
- power supplies, 81
- transformers, 82
- transistors, 83–84

Active-participant model, 137
American wire gauge (AWG), 26–28, 60–61
Ammeters, 49
Anarchic chaos, 140
AND circuit, 124
Arduino-compatible microcomputer, 67
AWG. *See* American wire gauge (AWG)

■ B

Barrier strip, 30–31
Bipolar junction transistors (BJTs), 83, 84
Bolts, 33
Budgeting, 14–15

■ C

Capacitors

- definition, 76
- electrolytic capacitors, 77
- schematic symbols, 78
- in series and parallel, 130

Charge status indicator, 155
Coin cell

- electrical goodness measurement, 94
- lithium
 - installed backward, 92
 - LED lights up, 91–92

Components, electric and electronic circuits

- acquiring components, 84

- new components purchase, 85
- recycle, used components, 85–86

active components, 81

- batteries, 81
- diodes, 82–83
- integrated circuits, 84
- LEDs, 83
- power supplies, 81
- transformers, 82
- transistors, 83–84

conductors and interconnects

- connectors, 64–68
- description, 57
- electrical schematics, 57–58
- wire and cables, 58–64

data sheets, 86
passive components

- capacitors, 76–78
- inductors, 78–79
- resistors, 68–76
- switches, 79–80

Computers, 35–36
Conductors and interconnects

- connectors
 - clip leads, 65
 - description, 64
 - solderless breadboards, 66–68
- description, 57
- electrical schematics, 57–58
- wire and cables
 - conductivity, 61–62
 - description, 58–59
 - longer version, 60–61
 - Ohm's law, 62–63
 - short version, 59–60
 - storing, 63–64
 - testing, 63

Connectors

- clip leads, 65
- description, 64
- solderless breadboards

- Connectors, solderless breadboards (*cont.*)
 - Arduino-compatible microcomputer, 67
 - description, 66
 - prototype LED display, 68
 - tie points, 66
- Cozy corner lab
 - capacitors in series and parallel, 130
 - inductors in series and parallel, 130
 - LEDs, in series and parallel, 131–133
 - parallel and series circuits
 - assembly instructions, 119
 - batteries in, 122–123
 - components, 118
 - in different view, 120–121
 - schematic diagram, 118
 - troubleshooting, 119–120
 - rehabilitation, work station, 105–106
 - components, 115–116
 - divide, 107–109
 - lighting, 112
 - power source, 110–111
 - taxonomy, 106–107
 - tools, 112–114
 - under-desk environment, 115
 - resistors
 - in parallel, 129
 - in series, 126
 - switches
 - in parallel, 124
 - in series, 123
 - three-way, 125–126

■ D

- Dallas Personal Robotics Group (DPRG), 17, 101–102, 139
- DC voltmeter, 156–157
- Digital caliper, 46, 47
- Digital storage oscilloscope (DSO), 53–54
- Digital voltage meter, 159
- Diodes, 82–83
- Double-throw switches, 80
- DPRG. *See* Dallas Personal Robotics Group (DPRG)
- Drawing, 23
- Drills, 40–43
- DSO. *See* Digital storage oscilloscope (DSO)

■ E, F, G

- Electrical experiment
 - LED
 - defective, 95
 - installed backward, 92–93
 - lights up when attached to lithium coin cell, 91–92
 - on solderless breadboard, 95–98
 - parallel and series circuits, 117–118
- Electrolytic capacitors, 77
- Electronic measurement tools
 - ammeters, 49
 - ohmmeters, 49
 - voltmeters, 47–48
- Electronics lab
 - and classroom (*see* Lab and classroom)
 - budgeting, 14–15
 - cautionary tale, 17
 - electricity, working principles
 - practical approach, 9
 - theoretical approach, 7–8
 - environmental impact, 14
 - flashlight, 11–13
 - fundamental components, 4–5
 - goals, 6
 - ideas, 5–6
 - of Harold Timmis, 16
 - planning, 2
 - portable (*see* Portable mini-lab)
 - Robot Clubhouse, 17
 - safety, 10
 - space for, 3
 - tools, 3–4 (*see also* Tools)
- Environmental impact, 14

■ H

- Hackerspaces, 139
- Hand tools, 114
 - computers, 35–36
 - pliers and tweezers, 29–30
 - screwdriver, 30–33
 - screws, bolts and nuts, 33
 - wire crimpers, 34–35
 - wire cutters, 23–25, 29
 - wire strippers, 25–29
- Harold Timmis' lab, 16

I, J, K

- Indicators, 155
- Inductors
 - DC motors, 79
 - description, 78
 - usage, 79
- Infrared LEDs, 132
- Inspection equipment, 45–46
- Insulators, 8
- Integrated circuits, 84

L

- Lab and classroom
 - group
 - coworkers and fellow students, 138
 - family, 137
 - friends, 138
 - general public, 139–140
 - special-interest groups, 139
 - presentations, 143
 - role
 - facilitator/coordinator, 135
 - observer, 137
 - participant, 137
 - teacher/presenter, 136
 - shared resource
 - courteous guest, 141
 - hospitable host, 140–141
 - workstations
 - description, 142
 - safety planning, 142
- Laboratory set up. *See* Electronics lab
- Laptop charger, 149
- Laser cutters, 43
- Light-emitting diodes (LEDs), 83
 - care and feeding, 127–128
 - circuit on solderless breadboard, 95–98
 - curiosities, 126–127
 - defective, 95
 - installed backward, 92–93
 - in series and parallel, 131–33
 - lights up when attached to lithium coin cell, 91–92
 - self-control, lack of, 127
 - uses, 100

M

- Magnifying lens, 46
- Metal-oxide–semiconductor field-effect transistor (MOSFET), 84
- Modern digital storage oscilloscope, 52–53
- Mobile electronics lab. *See* Portable mini-lab
- MOSFET. *See* Metal-oxide–semiconductor field-effect transistor (MOSFET)
- Multimeters, 50–51, 94

N

- Noisebridge organization, 140
- Nuts, 33

O

- Ohmmeters, 49
- Ohm’s law
 - description, 49
 - application, 49, 62–63
- OR circuit, 124
- Oscilloscopes
 - functions of, 51
 - modern, 52–54
 - tiny, 54–55

P, Q

- Parallel and series circuits
 - assembly instructions, 119
 - batteries in, 122–123
 - in different view, 120–121
 - schematic diagram, 118
 - troubleshooting, 119–120
- Passive electrical and electronic components
 - capacitors, 76–78
 - inductors, 78–79
 - resistors, 68–76
 - switches, 79–80
- Pencil-grip style, soldering irons, 39
- Permanent circuit, 95–97
- Physical measurement devices, 46–47
- Pliers and tweezers, 29–30
- Portable mini-lab
 - advantages, 88
 - compact executive model

Portable mini-lab, compact executive model
(*cont.*)

- electrical experiments (*see* Electrical experiments)

- lab deployed on desktop, 89–90

- components, 89

- DPRG, 101–102

- features, 89

- robotics lab, 103

- travel, 87

Potentiometer, 74–75

Power-on indicator, 155

Power rail attachment, 99

Power supplies, 55–56, 81–82, 145–146

Power tools

- 3D printers, 44

- drills, 40–43

- laser cutters, 43

Professional bench power supply, 146

R

Resistors

- color codes, 72–73

- description, 68

- location, 95

- in parallel, 129

- in permanent circuit, 97

- power ratings, 73

- schematic symbols and reference

- designators, 70–71

- in series, 126

- specialty resistors, 75–76

- standard values and tolerances, 71–72

- through-hole and surface-mount resistors, 69–70

- variable resistors, 74–75

RIGOL DS1052E oscilloscope, 54

Robot Clubhouse, 17

S

Shunt resistor, 158

Single-pole double-throw (SPDT) switch, 125

Single-throw switches, 80

Soldering

- definition, 4

- instructions for, 37–38

- tools for, 113

Solderless breadboards, 66

Arduino-compatible microcomputer, 67

- description, 66

- prototype LED display, 68

- tie points, 66

- types of, 117

SPDT switch. *See* Single-pole double-throw (SPDT) switch

Stereo microscope, 45

Surface-mount resistors, 69–70

Switches

- description, 79

- double-throw switch, 80

- in parallel, 124

- in series, 123

- single-throw switch, 80

- three-way, 125–126

T

Tablet computers, 91

Tabletop drill press, 42

Tektronix 475A oscilloscope, 52

Temperature-controlled soldering station, 113

Terminal block, 31–32

Test and measurement equipment

- multimeters, 50–51

- oscilloscopes

- functions of, 51

- modern, 52–54

- Tektronix 475A, 52

- tiny, 54–55

- power supplies, 55

3D printers, 44

Three-way switch, 125–126

Through-hole resistors, 69–70

Tools

- earmuffs, 22

- electronic measurement

- ammeters, 49

- ohmmeters, 49

- voltmeters, 47–48

- eye protection, 21

- for soldering, 37–40

- hand

- computers, 35–36

- pliers and tweezers, 29–30

- protection, 22

- screwdriver, 30–33

- screws, bolts and nuts, 33

- wire crimpers, 34–35

- wire cutters, 23–25, 29
- wire strippers, 25–29
- hearing protection, 22
- indicators, 155
- inspection equipment, 45–46
- mind, 19–21
- physical measurement devices, 46–47
- power
 - 3D printers, 44
 - drills, 40–43
 - laser cutters, 43
- power-on indicator, 155
- power supply, 145–46
- USB charger
 - description, 147–148
 - voltage measurement, 149–153
- Transformers, 82
- Transistors
 - BJTs, 83
 - description, 83
 - MOSFET, 84
- Troubleshooting, 2

■ **U**

- Unrepairable subassemblies, 127
- USB charger
 - cable

- colors and functions, 152
- internal wires, 151
- description, 147–148
- regulated power from, 155
- voltage measurement, 149–153

■ **V**

- Variable resistors, 74–75
- Voltmeters, 47–48

■ **W, X, Y, Z**

- Weller controlled-temperature soldering station, 37
- Wire and cables
 - conductivity, 61–62
 - description, 58–59
 - longer version, 60–61
 - Ohm’s law, 62–63
 - short version, 59–60
 - storing, 63–64
 - testing, 63
- Wire crimpers, 34–35
- Wire cutters, 23–25, 29
- Wire strippers, 25–29
- Wood screws, 33
- Workshop. *See* Electronics lab

Building Your Own Electronics Lab



Dale Wheat

Apress®

Building Your Own Electronics Lab

Copyright © 2012 by Dale Wheat

All rights reserved. No part of this work may be reproduced or transmitted in any form or by any means, electronic or mechanical, including photocopying, recording, or by any information storage or retrieval system, without the prior written permission of the copyright owner and the publisher.

ISBN-13 (pbk): 978-1-4302-4386-1

ISBN-13 (electronic): 978-1-4302-4387-8

Trademarked names, logos, and images may appear in this book. Rather than use a trademark symbol with every occurrence of a trademarked name, logo, or image we use the names, logos, and images only in an editorial fashion and to the benefit of the trademark owner, with no intention of infringement of the trademark. The use in this publication of trade names, trademarks, service marks, and similar terms, even if they are not identified as such, is not to be taken as an expression of opinion as to whether or not they are subject to proprietary rights.

President and Publisher: Paul Manning

Lead Editor: Matt Moodie

Technical Reviewer: Cliff Wooton

Editorial Board: Steve Anglin, Mark Beckner, Ewan Buckingham, Gary Cornell, Morgan Ertel,

Jonathan Gennick, Jonathan Hassell, Robert Hutchinson, Michelle Lowman, James Markham,

Matthew Moodie, Jeff Olson, Jeffrey Pepper, Douglas Pundick, Ben Renow-Clarke,

Dominic Shakeshaft, Gwenan Spearing, Matt Wade, Tom Welsh

Coordinating Editor: Brigid Duffy

Copy Editors: Damon Larson

Compositor: Bytheway Publishing Services

Indexer: SPi Global

Cover Designer: Anna Ishchenko

Distributed to the book trade worldwide by Springer Science+Business Media, LLC., 233 Spring Street, 6th Floor, New York, NY 10013. Phone 1-800-SPRINGER, fax (201) 348-4505, e-mail orders-ny@springer-sbm.com, or visit www.springeronline.com.

For information on translations, please e-mail rights@apress.com, or visit www.apress.com.

Apress and friends of ED books may be purchased in bulk for academic, corporate, or promotional use. eBook versions and licenses are also available for most titles. For more information, reference our Special Bulk Sales—eBook Licensing web page at <http://www.apress.com/bulk-sales>.

The information in this book is distributed on an “as is” basis, without warranty. Although every precaution has been taken in the preparation of this work, neither the author(s) nor Apress shall have any liability to any person or entity with respect to any loss or damage caused or alleged to be caused directly or indirectly by the information contained in this work.

Any source code or other supplementary materials referenced by the author in this text is available to readers at www.apress.com. For detailed information about how to locate your book’s source code, go to <http://www.apress.com/source-code/>.

To my father, John H. Wheat, who patiently taught me about electricity and electronics over 40 years ago. To this day, I remain fascinated by it. My life has been enriched in so many ways by the many things that I learned from my father.

Contents

■ About the Author	xi
■ About the Technical Reviewer	xii
■ Acknowledgments	xiii
■ Introduction	xiv
■ Chapter 1: Planning Your Electronics Workshop	1
What to Expect.....	1
It Starts with a Plan	2
A Broad Outline.....	2
A Little Time.....	2
A Little Space.....	3
Basic Tools	3
Fundamental Components.....	4
Ideas	5
Goals.....	6
Inspiration!	7
How Electricity Works.....	7
The Theoretical Approach.....	7
A Practical Approach	9
Safety.....	10
Lighten Up!	11
Environmental Impact.....	14

Budgeting	14
Buying New	14
Finding Used.	15
Harvesting or Recycling.	15
Some Example Workshops	16
A Fresh Start.....	16
The Robot Clubhouse.	17
A Cautionary Tale.	17
Summary	18
■ Chapter 2: Building Your Tool Chest	19
The Most Important Tool Ever	19
Care and Feeding of Your Brain.	21
All Those Other Bits, Too	21
Basic Hand Tools	22
Wire Cutters and Wire Strippers	23
Pliers and Tweezers	29
Screwdrivers, Nut Drivers, Wrenches, and Ratchets.	30
Screws, Bolts, and Nuts	33
More Specialized Hand Tools	34
Wire Crimpers.....	34
Computers	35
Tools for Soldering	37
Power Tools	40
Drills and Drill Bits.....	40
Laser Cutters and 3D Printers	43
Basic Test and Measurement Equipment	44

Physical Measurement Devices.....	46
Simple Electronic Measurement Tools.....	47
Advanced Test and Measurement Equipment.....	49
Multimeters.....	50
Oscilloscopes.....	51
Power Supplies.....	55
Organizing Your Tools.....	56
Summary.....	56
■ Chapter 3: Components.....	57
Conductors and Interconnects.....	57
Electrical Schematics.....	57
Wire and Cables.....	58
Connectors.....	64
Passive Components.....	68
Resistors.....	68
Capacitors.....	76
Inductors.....	78
Switches.....	79
Active Components.....	81
Power Supplies.....	81
Diodes.....	82
LEDs.....	83
Transistors.....	83
Integrated Circuits.....	84
Acquiring Components.....	84
Buying New Components.....	85
Recycling Used Components.....	85

Component Data Sheets	86
Summary	86
■ Chapter 4: A Portable Mini-Lab	87
Have Lab, Will Travel	87
The Compact Executive Model.....	87
No Soldering Required.....	90
The Ever-Shrinking Computing Device.....	91
Electrical Experiments You Can Perform	91
Lighten Up, 20th Century Style	91
A Slightly More Permanent Circuit.....	95
Multiple Uses for the LED	100
The Special Project Portable Laboratory.....	101
Summary	104
■ Chapter 5: The Cozy Corner Lab	105
The Rehabilitation of a Small but Useful Area	105
Science to the Rescue!.....	106
Organization	107
The Great Divide	107
Adding a Power Source	110
A Clean, Well-Lighted Space	111
Tools	112
Under the Desk.....	115
Components.....	115
Where to Go from Here	116
Projects.....	116
Parallel and Series Circuits	117
Batteries in Series and Parallel	122

Switches in Series.....	123
Switches in Parallel.....	124
The Three-Way Switch.....	125
Resistors in Series.....	126
Resistors in Parallel.....	129
Capacitors in Series and Parallel.....	130
Inductors in Series and Parallel.....	130
LEDs in Series and Parallel.....	131
Summary.....	133
■ Chapter 6: The Small Group Lab and Classroom.....	135
Know Yourself.....	135
Facilitator or Coordinator.....	135
Teacher or Presenter.....	136
Participant.....	137
Observer.....	137
Know Your Group.....	137
Your Family.....	137
Your Friends.....	138
Coworkers and Fellow Students.....	138
Special-Interest Groups.....	139
The General Public.....	139
A Shared Resource.....	140
Be a Hospitable Host.....	140
Be a Courteous Guest.....	141
Workstations.....	142
Safety Planning.....	142
Presentations.....	143
Summary.....	143

■ Appendix A: Getting Started with Tool Building	145
A Very Simple Power Supply	145
An Easy 2.5 Watts	147
Adding Features.....	154
Various Indicators.....	155
Power-On Indicator.....	155
Power Supply Voltage.....	156
Power Supply Current.....	158
Summary	159
■ Index	161

About the Author



■ **Dale Wheat** is a full-time freelance writer, specializing in electronics and embedded systems. He has written several articles for technical and hobbyist magazines such as *Circuit Cellar*, O'Reilly's *MAKE* magazine, and *Elektor*. He teaches classes on electronics, microcontrollers, and soldering skills. He designs and sells DIY electronics kits from his web site, <http://dalewheat.com>. Before becoming a full-time writer, Dale consulted as a computer programmer and systems analyst for several companies, including IBM, MCI, and GTE (now Verizon). Dale is a two-term past president of the Dallas Personal Robotics Group, the world's oldest personal robotics club. He is a member of the National Honor Society, Phi Theta Kappa, and intends to continue his education as long as they keep the doors open. He lives with his wife, Anne, near Dallas, Texas.

About the Technical Reviewer



■ Cliff Wootton is a former Interactive TV systems architect at BBC News. The "News Loops" service developed there was nominated for a BAFTA and won a Royal Television Society Award for Technical Innovation. An invited speaker on pre-processing for video compression at the Apple WWDC conference. Taught post graduate MA students about real-world computing, multimedia, video compression, metadata and researching the deployment of next generation interactive TV systems based on open standards.

Currently working on R&D projects investigating new Interactive TV technologies, involved with MPEG standards working groups, writing more books on the topic and speaking at conferences when not lecturing on Multimedia at the University of the Arts in London.

Acknowledgments

This book was Michelle Lowman's idea. I just wrote down some of the words.

Corbin Collins and Brigid Duffy, coordinating editors at Apress, helped keep me on track with this project, despite all my best efforts. Cliff Wootton and Alan Smith provided excellent insight and suggestions to help the chapters along. The entire Apress editorial and production teams make what could be a hard job into a thing of joy.

My wife, Anne, continues to buy into the fantasy that I am a "professional writer," giving me the time and space I need to do this. Her patience, love, support, and trust make all the difference in the world.

My good neighbor and friend Jerry Johnson's fervent prayers and constant encouragement and enthusiasm really helped pull this project through the difficult times that were encountered. While I was complaining about "narrative pacing and clarity," he underwent brain surgery (twice) and chemotherapy for cancer, always with a smiling laugh and a twinkle in his eye.